

PAN AIR - A Computer Program for Predicting Subsonic or Supersonic Linear Potential Flows About Arbitrary Configurations Using A Higher Order Panel Method

Volume III - Case Manual (Version 1.0)

Richard T. Medan (Editor), Alfred E. Magnus, Kenneth W. Sidwell, and Michael A. Epton
Boeing Military Airplane Company
Seattle, Washington

Prepared for
Ames Research Center
and
Langley Research Center
under Contract NAS2-9830

and for the
Air Force Aeronautical Systems Division
Air Force Wright Aeronautical Laboratories
Naval Coastal Systems Center

nt
ed
es
id
or



National Aeronautics and
Space Administration

Ames Research Center
Moffett Field, California 94035



10/10/10

10/10/10

10/10/10

10/10/10



TABLE OF CONTENTS

	<u>PAGE</u>
ACKNOWLEDGEMENTS	iv
SUMMARY	1
INTRODUCTION	2
DIRECTORY OF CASES	4
REFERENCES	5
FIGURES	7
1. EIGHT PANEL DELTA WING.....	1-1
2. THIN RECTANGULAR WING	2-1
3. WEAPONS CARRIAGE AIRPLANE	3-1
4. THIN DELTA WING	4-1
5. NASA WING-BODY	5-1
6. THIN WING WITH DEFLECTED FLAP	6-1
7. TWO-DIMENSIONAL AIRFOIL DESIGN	7-1
8. THIN WING DESIGN	8-1
9. NACELLE	9-1
10. ADDED MASS VALIDATION	10-1

ACKNOWLEDGEMENTS

The authors wish to thank the following for their ideas and/or material:

Ralph Carmichael, NASA Ames Research Center.
Ed Ehlers, Boeing Commercial Airplane Company.
Larry Erickson, NASA Ames Research Center.
Forrester Johnson, Boeing Commercial Airplane Company.
Ed Tinoco, Boeing Commercial Airplane Company.

PAN AIR - A COMPUTER PROGRAM FOR PREDICTING
SUBSONIC OR SUPERSONIC LINEAR POTENTIAL FLOWS ABOUT
ARBITRARY CONFIGURATIONS
USING A HIGHER ORDER PANEL METHOD.

VOLUME III - CASE MANUAL. (VERSION 1.0)

Richard T. Medan (editor),
Alfred E. Magnus,
Kenneth W. Sidwell, and
Michael E. Epton

Boeing Computer Services Company, and
Boeing Military Airplane Company

SUMMARY

Numerous applications of the PAN AIR computer program system are presented. PAN AIR is a user-oriented tool for analyzing and/or designing aerodynamic configurations in subsonic or supersonic flow using a technique generally referred to as a "higher order panel method". Problems solved include simple wings in subsonic and supersonic flow, a wing-body in supersonic flow, wing with deflected flap in subsonic flow, design of two-dimensional and three-dimensional wings, axisymmetric nacelle in supersonic flow, and wing-canard-tail-nacelle-fuselage combination in supersonic flow.

INTRODUCTION

PAN AIR can be used to analyze and/or design aerodynamic configurations in subsonic or supersonic flow using a technique generally referred to as a "higher order panel method". This manual is a compendium of stand-alone case documents each of which describes an aerodynamic problem solved using PAN AIR. See references 1 to 4 for further PAN AIR documentation.

The purposes of this Case Manual are:

- (a) to provide a central record of sample problems executed by PAN AIR,
- (b) to illustrate the range of capabilities of PAN AIR,
- (c) to help the user formulate his problems quickly and easily by providing input listings which he can use as models for his own input decks,
- (d) to illustrate alternative flow modeling techniques,
- (e) to illustrate and record novel or unusual applications of PAN AIR, and
- (f) to identify which PAN AIR features and options have been validated.

Several of the case writeups compare results with a code that is described in references 5 and 6 and that has become known as the "PAN AIR pilot code". The pilot code has been verified to be generally very accurate (e.g., reference 6), and the equations and coding were developed totally independently of PAN AIR. Therefore, it is felt that comparisons to the pilot code are a valid method of verifying PAN AIR. Additional PAN AIR applications appear in reference 7.

An explanation of the PAN AIR terminology appearing in some of the following writeups is given in the Engineering Glossary and Index which appears in section 9.0 of the User's Manual (ref. 2). Also, an understanding of the input listings in the following case documents may be facilitated by reference to section 7 of the User's Manual. In particular, note that most of the input records in the input listings are labeled with a slash (indicating that what follows is a comment) followed by the number of the record, with the numbering scheme being that of section 7 of the User's Manual.

The PAN AIR program system is available on magnetic tape from

COSMIC
112 Barrow Hall
University of Georgia
Athens, Georgia 30602

(404) 542-3265

In addition to the program, the magnetic tape includes all of the sample cases mentioned herein (with some insignificant differences) and output data for some of these cases.

DIRECTORY OF CASES

A synopsis of the PAN AIR standard test cases described herein appears below. In addition, refer to Table 1 to ascertain which PAN AIR options have been validated and illustrated by these test cases. Note also the "EV" column in Table 1. EV stands for "Enhanced Validation", and actually represents a large number of cases developed to thoroughly test PAN AIR. The enhanced validation cases are not formally documented. In the descriptions that follow, "thin wing" refers to a mean-surface model and actual surface models are referred to as "thick".

<u>CASE</u>	<u>TITLE</u>	<u>KEY WORDS</u>
1	Eight panel delta wing	Thick wing, class 1 boundary conditions
2	Thin rectangular wing	Thin wing, multiple right hand sides, specified flow, local onset flow, rotational onset flow.
3	Weapons carriage airplane	Wing-body with inlet and tail, supersonic flow, thick configuration with thin wing, superinclined panels
4	Thin delta wing	Doublets alone, thin wing, Supersonic flow, asymmetric geometry
5	NASA wing-body	Wing-body, two planes of symmetry, supersonic flow, thick wing
6	Thin wing with deflected flap	Thin wing, exact flap deflection, subsonic flow, specified flow, local onset flow
7	Two-dimensional airfoil design	Subsonic flow, design, thick wing
8	Thin wing design	Thickness design, camber design, supersonic flow
9	Nacelle	Superinclined panels, inlet barrier, supersonic flow, sources alone network

10 Added mass validation

Added mass coefficients and surface flow properties of triaxial ellipsoids, ellipsoidal flat plates, spheres near a wall, rectangular flat plates, and parallelepipeds.

REFERENCES

1. Magnus, Alfred E.; and Epton, Michael A.: PAN AIR - A Computer Program for Predicting Subsonic or Supersonic Linear Potential Flows about Arbitrary Configurations Using a Higher Order Panel Method. Volume I - Theory Document (Version 1.0). NASA CR-3251, 1980.
2. Sidwell, Kenneth W.; Baruah, Pranab K.; and Bussoletti, John E.: PAN AIR - A Computer Program for Predicting Subsonic or Supersonic Linear Potential Flows about Arbitrary Configurations Using a Higher Order Panel Method. Volume II - User's Manual (Version 1.0). NASA CR-3252, 1980.
3. Sidwell, Kenneth W.; and Derbyshire, Thomas: PAN AIR - A Computer Program for Predicting Subsonic or Supersonic Linear Potential Flows about Arbitrary Configurations Using a Higher Order Panel Method. Summary Document (Version 1.0). NASA CR-3250, 1981.
4. Baruah, Pranab K.; Bussoletti, John E.; Massena, William A.; Nelson, Franklin D.; Purdon, David J.; and Tsurusaki, Kiyoharu: PAN AIR - A Computer Program for Predicting Subsonic or Supersonic Linear Potential Flows about Arbitrary Configurations Using a Higher Order Panel Method. Volume IV - Maintenance Document (Version 1.0). NASA CR-3254, 1980.
5. Moran, J.; Tinoco, E. N.; and Johnson, F. T.: User's Manual - Subsonic/Supersonic Advanced Panel Pilot Code. NASA CR-152047, 1978.
6. Ehlers, F. Edward; Epton, Michael A.; Johnson, Forrester T.; Magnus, Alfred E.; and Rubbert, Paul E.: A Higher Order Panel Method for Linearized Supersonic Flow. NASA CR-3062, May 1979.
7. Carmichael, R. L.; and Erickson, L. L.: PAN AIR - A Higher Order Panel Method for Predicting Subsonic or Supersonic Linear Potential Flows about Arbitrary Configurations. AIAA paper 81-1255, June, 1981.

PANAIR option	SAMPLE TEST CASE NUMBER									
	1	2	3	4	5	6	7	8	9	EV
GLOBAL DATA GROUP	:	:	:	:	:	:	:	:	:	:
G1 Global Data Group Identifier	:	:	:	:	:	:	:	:	:	:
Default Option (NEW).....	V	V	V	V	V	V	V	V	V	V
NEW.....	:	:	:	:	:	:	:	:	:	V
REPLACE.....	:	:	:	:	:	:	:	:	:	V
UPDATE.....	:	:	:	:	:	:	:	:	:	V
G2 Problem Identification	:	:	:	:	:	:	:	:	:	:
Omitted.....	:	:	:	:	:	:	:	:	:	V
Entered.....	V	V	V	V	V	V	V	V	V	V
G3 User Identification	:	:	:	:	:	:	:	:	:	:
Omitted.....	:	:	:	:	:	:	:	:	:	V
Entered.....	V	V	V	V	V	V	V	V	V	V
G4 Configuration and Flow Symmetry	:	:	:	:	:	:	:	:	:	:
Omitted.....	V	V	V	:	:	V	:	V	:	V
ASYMMETRIC-GEOMETRY.....	:	:	:	V	:	:	:	:	:	V
FIRST-PLANE.....	:	:	:	V	V	:	:	:	:	V
Default.....	:	:	:	:	:	:	V	:	V	:
Default Plane.....	:	:	:	:	V	:	:	:	:	V
Specified Plane.....	:	:	:	V	:	:	:	:	:	V
Default Point.....	:	:	:	:	V	:	:	:	:	V
Specified Point.....	:	:	:	V	:	:	:	:	:	V
Default Flow Type.....	:	:	:	:	V	:	:	:	:	:
ASYMMETRIC-FLOW.....	:	:	:	:	:	:	:	:	:	B
SYMMETRIC-FLOW.....	:	:	:	V	:	:	:	:	:	V
GROUND-EFFECT.....	:	:	:	:	:	:	:	:	:	V
SECOND-PLANE.....	:	:	:	:	V	:	V	:	V	V
Default Plane.....	:	:	:	:	:	:	V	:	:	V
Specified Plane.....	:	:	:	:	V	:	:	:	:	V
ASYMMETRIC-FLOW.....	:	:	:	:	:	:	:	:	:	B
SYMMETRIC-FLOW.....	:	:	:	:	V	:	V	:	V	V
GROUND-EFFECT.....	:	:	:	:	:	:	:	:	:	V
G5 Compressibility	:	:	:	:	:	:	:	:	:	:
Mach Number	:	:	:	:	:	:	:	:	:	:
Omitted.....	:	:	:	:	:	:	:	:	:	V
Subsonic.....	:	V	:	:	:	V	V	:	:	V
Supersonic.....	V	:	V	V	V	:	:	V	V	V
CALPHA and CBETA	:	:	:	:	:	:	:	:	:	:
Default + Asymmetric.....	:	:	:	V	:	:	:	:	:	V
Default + 1 Symmetry Plane..	:	V	:	:	:	V	:	:	:	V
Default + 2 Symmetry Planes:	:	:	:	:	V	:	V	:	V	V
Entered	:	:	:	:	:	:	:	:	:	:
CALPHA non-zero.....	:	:	V	V	:	:	:	V	:	V
CBETA non-zero.....	:	:	:	:	:	:	:	:	:	V

(V implies Validated, B implies known bug)

Table 1. Validated PAN AIR options.

PANAIR option	SAMPLE TEST CASE NUMBER									
	1	2	3	4	5	6	7	8	9	EV
G6 Global Onset Flow	:	:	:	:	:	:	:	:	:	:
Omitted.....	:	:	:	:	:	V	V	:	:	V
Non Default ALPHA.....	V	V	V	V	V	:	:	V	V	V
Non Default BETA.....	:	:	:	:	:	:	:	:	:	V
Non Default UINF	:	V	:	:	:	:	:	:	:	V
Non Default Rotational Flow.....	:	V	:	:	:	:	:	:	:	V
Multiple Solutions.....	V	V	V	:	:	V	:	:	:	V
G7 Tolerance For Edge Matching	:	:	:	:	:	:	:	:	:	:
Omitted.....	V	:	:	V	:	:	V	V	V	V
Entered.....	:	V	:	V	V	:	:	:	:	V
No Edge Matching.....	:	:	V	:	:	V	:	:	:	V
G8 Surface Selection Options	:	:	:	:	:	:	:	:	:	:
Omitted (UPPER).....	V	:	V	:	:	:	:	V	:	V
UPPER.....	:	V	:	V	V	:	V	:	V	V
LOWER.....	:	V	:	:	:	:	:	V	:	V
UPLO.....	:	V	:	V	:	V	:	:	:	V
LOUP.....	:	:	:	:	:	:	:	:	:	V
AVERAGE.....	:	:	:	:	:	V	:	:	:	V
G9 Selection of Velocity Comp Method:	:	:	:	:	:	:	:	:	:	:
Omitted (BOUNDARY-CONDITION).....	V	V	V	V	V	:	V	:	V	V
BOUNDARY-CONDITION.....	:	:	:	:	:	:	:	:	:	V
VIC-LAMBDA.....	:	:	:	:	:	V	:	V	:	V
G10 Computational Option for Pressure:	:	:	:	:	:	:	:	:	:	:
Omitted (UNIFORM-ONSET-FLOW).....	:	:	:	:	:	:	:	:	:	V
UNIFORM-ONSET-FLOW.....	:	:	:	:	:	:	:	:	:	:
TOTAL-ONSET-FLOW.....	:	:	:	:	:	:	:	:	:	:
COMPRESSIBILITY-VECTOR.....	:	:	:	:	:	:	:	:	:	V
G11 Velocity Correction Options	:	:	:	:	:	:	:	:	:	:
Omitted (NONE).....	V	V	V	V	V	V	V	V	V	V
NONE.....	:	:	:	:	:	:	:	:	:	V
SA1.....	:	:	:	:	:	:	:	:	:	V
SA2.....	:	:	:	:	:	:	:	:	:	V
G12 Pressure Coefficient Rules	:	:	:	:	:	:	:	:	:	:
Omitted (ISENTROPIC).....	:	:	:	:	:	:	:	:	:	:
ISENTROPIC.....	V	V	:	V	V	:	:	V	V	V
SECOND-ORDER.....	V	V	V	V	V	V	V	V	V	V
REDUCED-SECOND-ORDER.....	:	:	:	:	:	:	:	:	:	V
SLENDER-BODY.....	:	:	:	:	:	:	:	:	:	V
LINEAR.....	:	V	:	V	:	V	:	:	:	V
G13 Ratio of Specific Heats	:	:	:	:	:	:	:	:	:	:
Omitted.....	V	V	V	V	V	V	V	V	V	V
Entered.....	:	:	:	:	:	:	:	:	:	:

(V implies Validated, B implies known bug)

Table 1. Continued

PANAIR option	SAMPLE TEST CASE NUMBER									EV	
	1	2	3	4	5	6	7	8	9		
G14 Reference Velocity for Pressure	:	:	:	:	:	:	:	:	:	:	:
Omitted.....	V	V	V	V	V	V	V	V	V	V	V
Entered.....	:	:	:	:	:	:	:	:	:	:	B
G15 STORE VIC MATRIX	:	:	:	:	:	:	:	:	:	:	:
Omitted.....	V	V	V	V	V	V	V	V	V	V	V
Entered.....	:	:	:	:	:	:	:	:	:	:	V
G16 STORE LOCAL ONSET FLOW	:	:	:	:	:	:	:	:	:	:	:
Omitted.....	V	:	V	V	V	V	V	V	V	V	V
Entered.....	:	V	:	:	:	:	:	:	:	:	V
G17 CHECKOUT PRINTS	:	:	:	:	:	:	:	:	:	:	:
Defaults.....	:	:	:	:	:	:	:	:	:	:	V
DIP 1.....	V	:	V	V	V	V	V	:	V	V	V
DIP 2.....	V	:	V	V	V	V	V	:	V	V	V
DIP 3.....	V	:	V	V	V	V	V	:	V	V	V
DQG 1.....	V	:	V	V	V	V	V	:	V	V	V
DQG 2.....	V	:	V	:	V	V	V	:	V	V	V
DQG 3.....	:	:	:	:	:	:	:	:	:	:	:
DQG 4.....	V	:	V	V	V	V	V	:	V	V	V
DQG 5.....	V	:	V	V	V	V	V	:	V	V	V
DQG 6.....	V	:	V	V	V	V	V	:	V	V	V
DQG 7.....	:	:	:	:	:	:	V	:	:	:	V
DEL.....	:	:	:	:	:	:	:	:	:	:	:
ALL.....	:	V	:	V	:	:	:	V	:	:	V

(V implies Validated, B implies known bug)

Table 1. continued.

PANAIR option	SAMPLE TEST CASE NUMBER									
	: 1	: 2	: 3	: 4	: 5	: 6	: 7	: 8	: 9	: EV
NETWORK DATA GROUP	:	:	:	:	:	:	:	:	:	:
N1 Network Data Group Identifier	:	:	:	:	:	:	:	:	:	:
Omitted (post-solution update)...	:	:	:	:	:	:	:	:	:	V
Entered.....	V	V	V	V	V	V	V	V	V	V
N2 Network Identifier Record Set	:	:	:	:	:	:	:	:	:	:
N2a Network Identifier.....	:	:	:	:	:	:	:	:	:	:
Default (NEW).....	:	:	V	:	:	V	V	V	:	V
NEW.....	V	V	:	V	V	:	:	:	V	V
REPLACE.....	:	:	:	:	:	:	:	:	:	V
SOLUTION-UPDATE.....	:	:	:	:	:	:	:	:	:	V
DELETE.....	:	:	:	:	:	:	:	:	:	V
N2b Grid Point Coordinates.....	V	V	V	V	V	V	V	V	V	V
N3 STORE VIC MATRIX	:	:	:	:	:	:	:	:	:	:
Omitted.....	V	V	V	V	V	V	V	V	V	V
Entered.....	:	:	:	V	:	V	V	V	:	V
N4 STORE LOCAL ONSET FLOW	:	:	:	:	:	:	:	:	:	:
Omitted.....	V	V	V	V	V	V	V	V	V	V
Entered.....	:	:	:	:	:	:	:	:	:	:
N5 Reflection in Plane of Symm. Tag	:	:	:	:	:	:	:	:	:	:
Omitted (Autom. Not Tagged).....	V	V	V	V	V	V	V	V	V	V
Omitted (Automatically Tagged)...	:	:	:	:	:	:	V	:	:	V
FIRST-PLANE.....	:	:	:	:	:	:	:	:	:	V
SECOND-PLANE.....	:	:	:	:	:	:	:	:	:	V
N6 Wake Flow Properties Tag	:	:	:	:	:	:	:	:	:	:
Omitted.....	V	V	V	V	V	V	V	V	V	V
Store Wake IC's.....	:	:	:	:	:	:	:	:	:	V
Store Wake IC's a VIC's.....	:	:	:	:	:	:	:	:	:	V
N7 Triangular Panel Tolerance	:	:	:	:	:	:	:	:	:	:
Omitted.....	V	V	V	V	V	V	V	V	V	V
Entered.....	:	:	:	:	:	:	:	:	:	V
N8 Network and Edge Update Tag	:	:	:	:	:	:	:	:	:	:
Omitted.....	V	V	V	V	V	V	V	V	V	V
Entire Network Tagged.....	:	:	:	:	:	:	V	:	:	V
Edges Only Tagged.....	:	:	:	:	:	:	V	:	:	V

(V implies Validated, B implies known bug)

Table 1. continued.

PANAIR option	SAMPLE TEST CASE NUMBER									EV	
	1	2	3	4	5	6	7	8	9		
N9 Boundary Condition Specification	:	:	:	:	:	:	:	:	:	:	:
Omitted.....	:	V	:	:	:	V	:	:	:	:	V
Default (LOCAL).....	:	.V	:	.V	.V	.V	.V	.V	.V	:	V
LOCAL.....	:	:	:	:	:	:	:	:	:	:	V
OVERALL.....	:	:	V	:	V	V	:	:	:	:	V
Class 1 Impermeable Surface	:	:	:	:	:	:	:	:	:	:	:
Subclass 1.....	V	:	V	:	V	:	V	:	V	:	V
Subclass 2.....	V	:	:	:	:	:	:	:	:	:	V
Subclass 3.....	:	:	V	V	:	V	:	:	:	:	V
Subclass 4.....	V	V	V	V	V	V	V	V	V	V	V
Subclass 5.....	:	:	:	:	:	:	:	:	:	:	V
Class 2 Specified Flux	:	:	:	:	:	:	:	:	:	:	:
Subclass 1.....	:	:	:	:	:	:	:	:	:	:	V
Subclass 2.....	:	:	:	:	:	:	:	:	:	:	V
Subclass 3.....	:	V	:	:	:	V	:	:	:	:	V
Subclass 4.....	:	:	:	:	:	:	:	:	:	:	V
Subclass 5.....	:	:	:	:	:	:	:	V	:	:	V
Class 3 Design	:	:	:	:	:	:	:	:	:	:	:
Subclass 1.....	:	:	:	:	:	:	V	:	:	:	V
Subclass 2.....	:	:	:	:	:	:	:	:	:	:	:
Subclass 3.....	:	:	:	:	:	:	:	:	:	:	:
Subclass 4.....	:	:	:	:	:	:	:	:	:	:	:
Subclass 5.....	:	:	:	:	:	:	:	:	:	:	:
Subclass 6.....	:	:	:	:	:	:	:	:	:	:	:
Class 4 Selected Terms	:	:	:	:	:	:	:	:	:	:	:
Left Side Index 1.....	:	:	V	:	:	:	:	:	:	V	:
" " " 2.....	:	:	V	:	:	:	:	:	:	:	:
" " " 3.....	:	:	:	:	:	:	:	:	:	:	:
" " " 4.....	:	:	:	:	:	:	:	:	:	:	V
" " " 5.....	:	:	V	:	:	:	:	:	:	V	V
" " " 6.....	:	:	V	:	:	:	:	:	:	:	V
" " " 7.....	:	:	:	:	:	:	:	:	:	:	:
" " " 8.....	:	:	:	:	:	:	:	:	V	:	V
" " " 9.....	:	:	:	:	:	:	:	:	:	:	:
" " " 10.....	:	:	:	:	:	:	:	:	:	:	:
" " " 11.....	:	:	:	:	:	:	:	V	:	:	V
" " " 12.....	:	:	:	:	:	:	:	V	:	:	V
" " " 13.....	:	:	:	:	:	:	:	:	:	:	V
" " " 14.....	:	:	:	:	:	:	:	:	:	:	:
" " " 15.....	:	:	:	:	:	:	:	:	:	:	:
" " " 16.....	:	:	:	:	:	:	:	:	:	:	:

(V implies Validated, B implies known bug)

Table 1. continued.

PANAIR option	SAMPLE TEST CASE NUMBER									
	1	2	3	4	5	6	7	8	9	EV
Mass Flux R. H. S. Index 1.....	:	:	:	:	:	:	:	:	V	:
" " " " " " 2.....	:	:	:	:	:	:	:	:	:	:
" " " " " " 3.....	:	:	V	:	:	:	:	:	V	V
Potential R. H. S. Index 1.....	:	:	:	:	:	:	:	:	:	V
" " " " " " 2.....	:	:	:	:	:	:	:	:	:	:
" " " " " " 3.....	:	:	V	:	:	:	:	:	V	V
Veloc. Design R. H. S. Index 1..	:	:	:	:	:	:	:	V	:	V
" " " " " " 2..	:	:	:	:	:	:	:	:	:	:
" " " " " " 3..	:	:	:	:	:	:	:	V	:	V
Veloc. Anal. R. H. S. Index 1..	:	:	:	:	:	:	:	:	:	V
" " " " " " 2..	:	:	:	:	:	:	:	:	:	:
" " " " " " 3..	:	:	:	:	:	:	:	:	:	:
Class 5.....	:	:	:	:	:	:	:	:	:	V
N10 Method of Velocity Computation	:	:	:	:	:	:	:	:	:	:
Default Classes 1, 2, 3.....	V	V	V	V	V	V	V	V	V	V
Default Classes 4, 5.....	:	:	V	:	:	:	:	:	:	V
LOWER-SURFACE-STAGNATION.....	:	:	:	:	:	:	:	:	:	:
UPPER-SURFACE-STAGNATION.....	:	:	:	:	:	:	:	:	:	V
NONSTAGNATION.....	:	:	:	:	:	:	:	:	V	V
N11 Singularity Types	:	:	:	:	:	:	:	:	:	:
Omitted.....	V	V	V	V	V	V	V	V	V	V
NOS.....	:	:	:	:	:	:	:	:	:	:
SA.....	:	:	V	:	:	:	:	V	V	V
SD1.....	:	:	:	:	:	:	:	:	:	:
SD2.....	:	:	:	:	:	:	:	:	:	:
NOD.....	:	:	:	:	:	:	:	:	V	V
DA.....	:	:	V	:	:	:	:	V	V	V
DD1.....	:	:	:	:	:	:	:	:	:	:
DFW.....	:	:	:	:	:	:	:	:	:	:
DW1.....	:	:	:	:	:	:	:	:	:	:
DW2.....	:	:	:	:	:	:	:	:	:	:
N12 Edge Control Point Locations	:	:	:	:	:	:	:	:	:	:
Omitted.....	V	V	V	V	V	V	V	V	V	V
SNE.....	:	:	:	:	:	:	:	:	:	:
DNE.....	:	:	:	:	:	:	:	:	:	V
N13 Remove Doublet Edge Matching	:	:	:	:	:	:	:	:	:	:
Omitted.....	V	V	V	V	V	V	V	V	V	V
Entered.....	:	:	:	:	:	:	:	:	:	V

(V implies Validated, B implies known bug)

Table 1. continued

PANAIR option	SAMPLE TEST CASE NUMBER									
	1	2	3	4	5	6	7	8	9	EV
N14 Closure Edge Boundary Condition	:	:	:	:	:	:	:	:	:	:
N14a Closure edge condition	:	:	:	:	:	:	:	:	:	:
Omitted.....	V	V	V	V	V	V	V	V	V	V
SNE.....	:	:	:	:	:	:	V	:	:	V
DNE.....	:	:	:	:	:	:	:	:	:	:
N14b Closure Term	:	:	:	:	:	:	:	:	:	:
TERM = AU.....	:	:	:	:	:	:	:	:	:	:
TERM = AL.....	:	:	:	:	:	:	:	:	:	:
TERM = AA.....	:	:	:	:	:	:	:	:	:	:
TERM = AD.....	:	:	:	:	:	:	V	:	:	V
TERM = BC.....	:	:	:	:	:	:	V	:	:	V
N14c Closure Solutions List	:	:	:	:	:	:	:	:	:	:
Omitted.....	:	:	:	:	:	:	V	:	:	V
Entered.....	:	:	:	:	:	:	:	:	:	V
N14d Closure Numerical Values	:	:	:	:	:	:	:	:	:	:
Global Value.....	:	:	:	:	:	:	:	:	:	B
Consecutive Ordering.....	:	:	:	:	:	:	V	:	:	V
Indexed Input.....	:	:	:	:	:	:	:	:	:	:
Single Point.....	:	:	:	:	:	:	:	:	:	:
Index Range.....	:	:	:	:	:	:	:	:	:	:
Index Global Range.....	:	:	:	:	:	:	:	:	:	:
N15 Coefficient of General B.C. Eq.	:	:	:	:	:	:	:	:	:	:
N15a Identifier	:	:	:	:	:	:	:	:	:	:
Omitted.....	V	V	V	V	V	V	V	V	V	V
Entered.....	:	:	:	:	:	:	:	:	:	V
N15b Equation Term	:	:	:	:	:	:	:	:	:	:
Left Hand Side	:	:	:	:	:	:	:	:	:	:
Mass Flux.....	:	:	:	:	:	:	:	:	:	V
Potential.....	:	:	:	:	:	:	:	:	:	V
Velocity.....	:	:	:	:	:	:	:	:	:	V
U.....	:	:	:	:	:	:	:	:	:	V
L.....	:	:	:	:	:	:	:	:	:	V
A.....	:	:	:	:	:	:	:	:	:	V
D.....	:	:	:	:	:	:	:	:	:	V
1st Equation.....	:	:	:	:	:	:	:	:	:	V
2nd Equation.....	:	:	:	:	:	:	:	:	:	V
Right Hand Side	:	:	:	:	:	:	:	:	:	:
Omitted.....	:	:	:	:	:	:	:	:	:	:
Mass Flux or Velocity.....	:	:	:	:	:	:	:	:	:	V
Potential.....	:	:	:	:	:	:	:	:	:	V
Tangential Velocity.....	:	:	:	:	:	:	:	:	:	V

(V implies Validated, B implies known bug)

Table 1. continued

PANAIR option	SAMPLE TEST CASE NUMBER									EV	
	1	2	3	4	5	6	7	8	9		
N15c Equation Solutions List	:	:	:	:	:	:	:	:	:	:	:
Omitted.....	:	:	:	:	:	:	:	:	:	:	V
Entered.....	:	:	:	:	:	:	:	:	:	:	V
N15d Equation Control Point Locs	:	:	:	:	:	:	:	:	:	:	:
ALL-CONTROL-POINTS.....	:	:	:	:	:	:	:	:	:	:	V
CENTER-CONTROL-POINTS.....	:	:	:	:	:	:	:	:	:	:	V
EDGE-CONTROL-POINTS.....	:	:	:	:	:	:	:	:	:	:	V
ADDITIONAL-CONTROL-POINTS....	:	:	:	:	:	:	:	:	:	:	V
N15e Equation Numerical Values	:	:	:	:	:	:	:	:	:	:	:
Global Value.....	:	:	:	:	:	:	:	:	:	:	V
Consecutive Ordering.....	:	:	:	:	:	:	:	:	:	:	:
Indexed Input.....	:	:	:	:	:	:	:	:	:	:	V
N16 Tangent Vectors for Design	:	:	:	:	:	:	:	:	:	:	:
N16a Tangent Vectors Identifier	:	:	:	:	:	:	:	:	:	:	:
Omitted.....	V	V	V	V	V	V	V	V	V	V	V
Entered.....	:	:	:	:	:	:	:	:	:	:	V
N16b Tangent Vectors Term	:	:	:	:	:	:	:	:	:	:	:
Left Hand Side	:	:	:	:	:	:	:	:	:	:	:
U.....	:	:	:	:	:	:	V	:	:	:	V
L.....	:	:	:	:	:	:	:	:	:	:	:
A.....	:	:	:	:	:	:	:	V	:	:	V
D.....	:	:	:	:	:	:	:	V	:	:	V
1st equation.....	:	:	:	:	:	:	V	V	:	:	V
2nd equation.....	:	:	:	:	:	:	:	V	:	:	V
Right Hand Side	:	:	:	:	:	:	:	:	:	:	:
1st equation.....	:	:	:	:	:	:	V	V	:	:	V
2nd equation.....	:	:	:	:	:	:	:	:	:	:	:
N16c Tangent Vectors Scaling	:	:	:	:	:	:	:	:	:	:	:
Omitted.....	:	:	:	:	:	:	V	V	:	:	V
UNALTERED.....	:	:	:	:	:	:	:	:	:	:	:
N16d Tangent Vectors Sol. List	:	:	:	:	:	:	:	:	:	:	:
Omitted.....	:	:	:	:	:	:	V	V	:	:	V
Entered.....	:	:	:	:	:	:	:	:	:	:	:
N16e Tang. Vect. C. P. Locations	:	:	:	:	:	:	:	:	:	:	:
ALL-CONTROL-POINTS.....	:	:	:	:	:	:	V	V	:	:	V
CENTER-CONTROL-POINTS.....	:	:	:	:	:	:	:	:	:	:	:
EDGE-CONTROL-POINTS.....	:	:	:	:	:	:	:	:	:	:	:
ADDITIONAL-CONTROL-POINTS....	:	:	:	:	:	:	:	:	:	:	:
N16f Tangent Vectors Num. Values	:	:	:	:	:	:	:	:	:	:	:
Global.....	:	:	:	:	:	:	:	:	:	:	:
Consecutive Ordering.....	:	:	:	:	:	:	:	:	:	:	:
Indexed.....	:	:	:	:	:	:	:	:	:	:	:
N16g Tang. Vec. Stand. Num. Val	:	:	:	:	:	:	:	:	:	:	:
COMPRESSIBILITY-DIRECTION....	:	:	:	:	:	:	:	:	:	:	:
MID-POINT.....	:	:	:	:	:	:	V	V	:	:	V

(V implies Validated, B implies known bug)

Table 1. continued

PANAIR option	SAMPLE TEST CASE NUMBER									EV
	1	2	3	4	5	6	7	8	9	
N17 Specified Flow Record Set	:	:	:	:	:	:	:	:	:	:
N17a Specified Flow Identifier	:	:	:	:	:	:	:	:	:	:
Omitted.....	V	V	V	V	V	V	V	V	V	V
Entered.....	:	V	:	:	:	V	V	V	:	V
N17b Specified Flow Term	:	:	:	:	:	:	:	:	:	:
TERM = 1.....	:	:	:	:	:	:	V	V	:	V
TERM = 2.....	:	V	:	:	:	V	:	V	:	V
N17c Specified Flow Symmetries	:	:	:	:	:	:	:	:	:	:
Omitted.....	:	:	:	:	:	:	:	:	:	B
INPUT.....	:	V	:	:	:	V	V	V	:	V
1ST.....	:	V	:	:	:	V	V	V	:	V
2ND.....	:	:	:	:	:	:	V	:	:	V
3RD.....	:	:	:	:	:	:	:	:	:	V
N17d Specified Flow Sol. List	:	:	:	:	:	:	:	:	:	:
Omitted.....	:	:	:	:	:	:	V	V	:	V
Entered.....	:	V	:	:	:	V	:	:	:	V
N17e Specified Flow C. P. Locs.	:	:	:	:	:	:	:	:	:	:
ALL.....	:	V	:	:	:	V	V	V	:	V
CENTER.....	:	:	:	:	:	:	V	V	:	V
EDGE.....	:	:	:	:	:	:	:	V	:	V
ADDITIONAL.....	:	:	:	:	:	:	:	V	:	V
N17f Specified Numerical Values	:	:	:	:	:	:	:	:	:	:
Global.....	:	V	:	:	:	V	V	V	:	V
Consecutive Ordering.....	:	:	:	:	:	:	V	V	:	V
Indexed Input.....	:	:	:	:	:	:	:	:	:	V
N18 Local Onset Flow Record Set	:	:	:	:	:	:	:	:	:	:
N18a Local Onset Flow Identifier	:	:	:	:	:	:	:	:	:	:
Omitted.....	V	V	V	V	V	V	V	V	V	V
Entered.....	:	V	:	:	:	V	:	:	:	V
N18b Local Onset Flow Term	:	:	:	:	:	:	:	:	:	:
ALPHA-BETA-MAGNITUDE.....	:	:	:	:	:	:	:	:	:	B
VXYZ.....	:	V	:	:	:	V	:	:	:	V
N18c Local Onset Flow Symmetries	:	:	:	:	:	:	:	:	:	:
Omitted.....	:	:	:	:	:	:	:	:	:	B
INPUT.....	:	V	:	:	:	V	:	:	:	V
1ST.....	:	V	:	:	:	V	:	:	:	V
2ND.....	:	:	:	:	:	:	:	:	:	:
3RD.....	:	:	:	:	:	:	:	:	:	:
N18d Local Onset Flow Sol. List	:	:	:	:	:	:	:	:	:	:
Omitted.....	:	:	:	:	:	:	:	:	:	:
Entered.....	:	V	:	:	:	V	:	:	:	V

(V implies Validated, B implies known bug)

Table 1. continued

PANAIR option	SAMPLE TEST CASE NUMBER									EV	
	1	2	3	4	5	6	7	8	9		
N18e Local Onset Flow C.P. Locs.	:	:	:	:	:	:	:	:	:	:	:
ALL.....	:	V	:	:	:	V	:	:	:	:	V
CENTER.....	:	:	:	:	:	:	:	:	:	:	:
EDGE.....	:	:	:	:	:	:	:	:	:	:	:
ADDITIONAL.....	:	:	:	:	:	:	:	:	:	:	:
N18f Local Onset Flow Num. Values	:	:	:	:	:	:	:	:	:	:	:
Global.....	:	V	:	:	:	V	:	:	:	:	V
Consecutive Ordering.....	:	:	:	:	:	:	:	:	:	:	:
Indexed.....	:	:	:	:	:	:	:	:	:	:	:
<u>GEOMETRIC EDGE MATCHING DATA GROUP</u>	:	:	:	:	:	:	:	:	:	:	:
GE1 Geometric Edge Matching Id	:	:	:	:	:	:	:	:	:	:	:
Omitted.....	V	V	:	V	V	:	V	V	V	:	V
Entered.....	:	:	V	:	:	V	:	:	:	:	V
GE2 Abutment Definition	:	:	:	:	:	:	:	:	:	:	:
Single Network.....	:	:	V	:	:	V	:	:	:	:	V
First Network Default.....	:	:	:	:	:	V	:	:	:	:	V
Subsequent Network Default....	:	:	V	:	:	V	:	:	:	:	V
ENTIRE Edge	:	:	V	:	:	:	:	:	:	:	V
Endpoint Pair	:	:	:	:	:	:	:	:	:	:	V
GE3 Abutment in Symmetry Planes	:	:	:	:	:	:	:	:	:	:	:
Omitted.....	:	:	V	:	:	V	:	:	:	:	V
FIRST.....	:	:	V	:	:	V	:	:	:	:	V
SECOND.....	:	:	:	:	:	:	:	:	:	:	V
BOTH.....	:	:	:	:	:	:	:	:	:	:	V
GE4 Smooth Edge Treatment Option	:	:	:	:	:	:	:	:	:	:	:
Omitted.....	:	:	V	:	:	V	:	:	:	:	V
Entered.....	:	:	:	:	:	:	:	:	:	:	V

(V implies Validated, B implies known bug)

Table 1. continued

PANAIR option		SAMPLE TEST CASE NUMBER									EV	
		1	2	3	4	5	6	7	8	9		
<u>FLOW PROPERTIES DATA GROUP</u>												
FPI	Group Identifier	:	:	:	:	:	:	:	:	:	:	:
	Omitted.....	:	:	:	:	:	:	:	:	:	:	V
	Default (NEW).....	V	V	V	V	V	V	V	V	V	V	V
	NEW.....	:	:	:	:	:	:	:	:	:	:	V
	REPLACE.....	:	:	:	:	:	:	:	:	:	:	V
	UPDATE.....	:	:	:	:	:	:	:	:	:	:	V
<u>Surface Flow Prop. Subgroup</u>												
SF1	Subgroup Identifier	:	:	:	:	:	:	:	:	:	:	:
	Omitted.....	:	:	:	:	:	:	:	:	:	:	V
	Entered.....	V	V	V	V	V	V	V	V	V	V	V
SF2	Networks + Images Selection	:	:	:	:	:	:	:	:	:	:	:
	Omitted.....	:	:	V	V	:	V	:	:	:	:	V
	ID - Name.....	:	V	:	V	V	:	V	V	:	:	V
	ID - Index.....	V	:	:	:	:	:	:	:	:	V	V
	Image - Default.....	:	V	:	:	:	:	V	:	:	V	V
	INPUT.....	V	:	:	V	V	:	:	V	:	V	V
	1ST.....	V	:	:	:	:	:	:	:	:	:	V
	2ND.....	:	:	:	:	:	:	:	:	:	:	V
	3RD.....	:	:	:	:	:	:	:	:	:	:	V
	Orient - Default.....	V	V	:	:	V	:	V	V	:	V	V
	RETAIN.....	:	:	:	V	:	:	:	:	:	:	V
	REVERSE.....	:	:	:	:	:	:	:	:	:	:	V
SF3	Solutions List	:	:	:	:	:	:	:	:	:	:	:
	Omitted.....	V	V	:	V	V	:	V	V	:	V	V
	Entered.....	V	V	V	V	:	V	:	:	:	:	V
SF4a	Point Types	:	:	:	:	:	:	:	:	:	:	:
	Omitted (CENTER).....	:	:	:	:	:	:	:	:	:	:	V
	GRID.....	:	:	:	:	:	:	:	:	:	:	V
	ALL.....	V	V	:	:	:	V	V	V	:	:	V
	CENTER.....	V	V	V	V	V	V	V	:	:	V	V
	EDGE.....	:	:	:	V	:	:	:	:	:	:	V
	ADDITIONAL.....	:	:	:	:	:	:	:	:	:	:	V
	ARBITRARY.....	:	:	:	:	:	:	:	:	:	:	V
SF4b	Arbitrary Points.....	:	:	:	:	:	:	:	:	:	:	V
SF5	Surface Selection Option	:	:	:	:	:	:	:	:	:	:	:
	Omitted.....	:	V	:	V	V	:	:	:	V	:	V
	UPPER.....	V	:	V	:	:	:	V	V	:	:	V
	LOWER.....	V	:	:	:	:	:	V	V	:	:	V
	UPLO.....	:	:	V	:	:	V	:	V	:	:	V
	LOUP.....	:	:	:	:	:	:	:	:	:	:	V
	AVERAGE.....	:	:	:	:	:	:	:	V	:	:	V

(V implies Validated, B implies known bug)

Table 1. continued

PANAIR option		SAMPLE TEST CASE NUMBER										
		1	2	3	4	5	6	7	8	9	EV	
SF6	Select. of Vel. Comp. Method											
	Omitted.....	V	V	V	V	V	V	V	V	V	V	V
	BOUNDARY-CONDITION.....							V				V
	VIC-LAMBDA.....				V			V				V
SF7	Comp. Option for Pressure											
	Omitted.....	V	V	V	V	V	V	V	V	V	V	V
	UNIFORM-ONSET-FLOW.....											V
	TOTAL-ONSET-FLOW.....		V									V
	COMPRESSIBILITY-VECTOR.....											V
SF8	Ratio of Specific Heats											
	Omitted.....	V	V	V	V	V	V	V	V	V	V	V
	Entered.....											V
SF9	Reference Velocity for Pressure											
	Omitted.....	V	V	V	V	V	V	V	V	V	V	V
	Entered.....											B
SF10a	Printout Options											
	Omitted.....											
	Default Options.....						V			V		V
	Integers.....											V
	Keywords.....											V
	ALL.....	V	V	V	V	V	V	V	V	V	V	V
SF10b	Velocity Correction Options											
	Omitted.....	V	V	V	V	V	V	V	V	V	V	V
	NONE.....											V
	SA1.....											
	SA2.....											
SF10c	Pressure Coefficient Rules											
	Omitted.....	V	V	V	V	V	V	V	V	V	V	V
	ISENTROPIC.....											V
	SECOND-ORDER.....											V
	REDUCED-SECOND-ORDER.....											V
	SLENDER-BODY.....											V
	LINEAR.....											V
SF11a	Data Base											
	Omitted.....					V						
	Default Options.....									V		V
	Integers.....											V
	Keywords.....											V
	ALL.....	V	V	V	V	V	V	V	V	V	V	V
SF11b	Velocity Correction Options											
	Omitted.....	V	V	V	V	V	V	V	V	V	V	V
	NONE.....											V
	SA1.....											
	SA2.....											

(V implies Validated, B implies known bug)

Table 1. continued

PANAIR option		SAMPLE TEST CASE NUMBER												
		1	2	3	4	5	6	7	8	9	EV			
SF11c	Pressure Coefficient Rules													
	Omitted.....	V	V	V	V	V	V	V	V	V	V	V	V	V
	ISENTROPIC.....													V
	SECOND-ORDER.....													V
	REDUCED-SECOND-ORDER.....													V
	SLENDER-BODY.....													V
	LINEAR.....													V
<u>Forces + Moments Subgroup</u>														
FM1	Subgroup Identifier													
	Omitted.....													
	Entered.....	V	V	V	V	V	V	V	V	V	V	V	V	V
FM2	Reference Parameters													
	Omitted.....	V	V	V	V	V	V	V	V	V	V	V	V	V
	SR Omitted.....				V									
	SR Entered.....				V									V
	CR Omitted.....													
	CR Entered.....				V									V
	BR Omitted.....													
	BR Entered.....													V
FM3	Axis Systems													
	Omitted.....	V		V	V									V
	RCS.....		V			V	V	V	V	V	V	V	V	V
	RCS - mrp.....								V					V
	SAS.....													V
	SAS - mrp.....													V
	WAS.....													V
	WAS - mrp.....													V
	BAS.....													V
	BAS - Euler angles.....													V
	BAS - mrp.....													V
FM4	Solutions List													
	Omitted.....				V	V		V	V	V	V	V	V	V
	Entered.....	V	V	V			V							V
FM5	Printout Options													
	Omitted.....		V	V	V	V					V	V	V	V
	NO.....													
	SAME.....													V
	ALL.....	V												V
	PANELS.....													V
	" - RCS.....													V
	" - SAS.....													V
	" - WAS.....													V
	" - BAS.....													V

(V implies Validated, B implies known bug)

Table 1. continued

PANAIR option	SAMPLE TEST CASE NUMBER									
	1	2	3	4	5	6	7	8	9	EV
COLSUM.....						V	V	V		V
" - RCS.....										V
" - SAS.....										
" - WAS.....										V
" - BAS.....										V
NETWORK.....						V	V	V		V
CONFIGURATION.....						V	V			V
FM6 Data Base Options										
Omitted.....		V	V	V	V				V	V
NO.....										
SAME.....						V		V		V
ALL.....										V
PANELS.....	V									V
" - RCS.....										
" - SAS.....										
" - WAS.....										
" - BAS.....										
COLSUM.....							V			V
" - RCS.....										
" - SAS.....										
" - WAS.....										
" - BAS.....										
NETWORK.....							V			V
CONFIGURATION.....							V			V
FM7 Case Identifier										
ID Omitted.....										V
ID Entered.....	V	V	V	V	V	V	V	V	V	V
FM8 Network + Images Selection										
Omitted.....			V			V				V
ID - Name.....		V		V	V		V	V		V
ID - Index.....	V								V	V
Image - Default.....		V		V						V
" - INPUT.....	V			V	V		V	V	V	V
" - 1ST.....	V			V						V
" - 2ND.....										V
" - 3RD.....										V
Orient - Default.....	V	V			V	V	V	V	V	V
" - RETAIN.....				V						
" - REVERSE.....										V
FM - Defaulted.....	V	V		V	V	V	V	V	V	V
- PRESSURE-ONLY.....										
- MOMENTUM-TRANSFER.....										V

(V implies Validated, B implies known bug)

Table 1. continued

PANAIR option	SAMPLE TEST CASE NUMBER									
	: 1	: 2	: 3	: 4	: 5	: 6	: 7	: 8	: 9	: EV
FM9 Edge Force Calculation.....										
Omitted.....	V		V		V	V	V	V	V	V
One Edge.....		V		V						V
Multiple Edges.....										
FM10 Moment Axis.....										
Omitted.....	V	V	V	V	V	V	V	V	V	V
Entered.....										V
FM11 Local Ref. Parameters										
Omitted.....	V	V	V	V	V	V	V	V	V	V
SR Omitted.....										V
SR Entered.....										V
CR Omitted.....										V
CR Entered.....										V
FM12 Surface Selection Options										
Omitted.....				V	V		V			V
UPPER.....										V
LOWER.....										
UPLO.....	V	V		V		V		V	V	V
LOUP.....			V							V
AVERAGE.....										V
FM13 Select. of Vel. Comp. Method										
Omitted.....	V	V	V	V	V	V	V	V	V	V
BOUNDARY-CONDITION.....							V			V
VIC-LAMBDA.....				V			V			V
FM14 Comp. Option for Pressures										
Omitted.....	V	V	V	V	V	V	V	V	V	V
UNIFORM-ONSET-FLOW.....										V
TOTAL-ONSET-FLOW.....		V								V
COMPRESSIBILITY-VECTOR.....										V
FM15 Velocity Correction Options										
Omitted.....	V	V	V	V	V	V	V	V	V	V
NONE.....										V
SA1.....										
SA2.....										
FM16 Pressure Coefficient Rules										
Omitted.....	V	V	V	V	V		V	V		V
ISENTROPIC.....						V			V	V
SECOND-ORDER.....										V
REDUCED-SECOND-ORDER.....										V
SLENDER-BODY.....										V
LINEAR.....						V				V
FM17 Ratio of Specific Heats										
Omitted.....	V	V	V	V	V	V	V	V	V	V
Entered.....										V

(V implies Validated, B implies known bug)

Table 1. continued

PANAIR option		SAMPLE TEST CASE NUMBER									EV	
		1	2	3	4	5	6	7	8	9		
FM18	Reference Velocity for Pressure	:	:	:	:	:	:	:	:	:	:	:
	Omitted.....	V	V	V	V	V	V	V	V	V	V	V
	Entered.....	:	:	:	:	:	:	:	:	:	:	B
FM19	Local Printout Options	:	:	:	:	:	:	:	:	:	:	:
	Omitted.....	V	V	V	V	V	V	V	V	V	V	V
	NO.....	:	:	:	:	:	:	:	:	:	:	:
	SAME.....	:	:	:	:	:	:	:	:	:	:	V
	ALL.....	:	:	:	:	:	:	:	:	:	:	:
	PANELS.....	:	:	:	:	:	:	:	:	:	:	V
	" - RCS.....	:	:	:	:	:	:	:	:	:	:	V
	" - SAS.....	:	:	:	:	:	:	:	:	:	:	V
	" - WAS.....	:	:	:	:	:	:	:	:	:	:	V
	" - BAS.....	:	:	:	:	:	:	:	:	:	:	V
	COLSUM.....	:	:	:	:	:	:	:	:	:	:	V
	" - RCS.....	:	:	:	:	:	:	:	:	:	:	V
	" - SAS.....	:	:	:	:	:	:	:	:	:	:	V
	" - WAS.....	:	:	:	:	:	:	:	:	:	:	V
	" - BAS.....	:	:	:	:	:	:	:	:	:	:	V
	NETWORK.....	:	:	:	:	:	:	:	:	:	:	V
	CONFIGURATION.....	:	:	:	:	:	:	:	:	:	:	V
FM20	Local Data Base Options	:	:	:	:	:	:	:	:	:	:	:
	Omitted.....	V	V	V	V	V	V	V	V	V	V	V
	NO.....	:	:	:	:	:	:	:	:	:	:	:
	SAME.....	:	:	:	:	:	:	:	:	:	:	V
	ALL.....	:	:	:	:	:	:	:	:	:	:	:
	PANELS.....	:	:	:	:	:	:	:	:	:	:	V
	" - RCS.....	:	:	:	:	:	:	:	:	:	:	V
	" - SAS.....	:	:	:	:	:	:	:	:	:	:	V
	" - WAS.....	:	:	:	:	:	:	:	:	:	:	V
	" - BAS.....	:	:	:	:	:	:	:	:	:	:	V
	COLSUM.....	:	:	:	:	:	:	:	:	:	:	V
	" - RCS.....	:	:	:	:	:	:	:	:	:	:	V
	" - SAS.....	:	:	:	:	:	:	:	:	:	:	V
	" - WAS.....	:	:	:	:	:	:	:	:	:	:	V
	" - BAS.....	:	:	:	:	:	:	:	:	:	:	V
	NETWORK.....	:	:	:	:	:	:	:	:	:	:	V
	CONFIGURATION.....	:	:	:	:	:	:	:	:	:	:	V
FM21	Accumulation Options	:	:	:	:	:	:	:	:	:	:	:
	Omitted.....	:	:	V	V	V	V	V	:	V	:	V
	Selected.....	V	V	:	:	:	:	:	V	:	:	V
	Vel. Comp. Selection.....	:	V	:	:	:	:	:	V	:	:	V
	Vel. Corr. Selection.....	:	V	:	:	:	:	:	:	:	:	V
	Pressure Rules Selection.....	V	V	:	:	:	:	:	:	:	:	V

(V implies Validated, B implies known bug)

Table 1. continued.

PANAIR option	SAMPLE TEST CASE NUMBER									
	: 1 :	: 2 :	: 3 :	: 4 :	: 5 :	: 6 :	: 7 :	: 8 :	: 9 :	EV :
<u>PRINT - PLOT DATA GROUP</u>	:	:	:	:	:	:	:	:	:	:
PP1 Group Identifier.....	:	:	:	:	:	:	:	:	:	:
Omitted.....	:	:	:	:	:	:	:	:	:	V
Entered.....	V	V	V	V	V	V	V	V	V	V
PP2a Geometry Data Identifier	:	:	:	:	:	:	:	:	:	:
Omitted.....	:	:	:	:	:	:	:	:	:	:
Entered.....	V	V	V	V	V	V	V	V	V	V
PP2b Network Selection	:	:	:	:	:	:	:	:	:	:
Omitted.....	V	V	V	:	:	V	V	V	V	V
Entered.....	:	:	:	V	V	:	:	:	:	:
PP3a Point Data Identifier	:	:	:	:	:	:	:	:	:	:
Omitted.....	:	:	:	:	:	:	:	:	:	:
Entered.....	V	V	V	V	V	V	V	V	V	V
PP3b Case Selection	:	:	:	:	:	:	:	:	:	:
Omitted.....	V	V	V	V	V	V	V	V	:	V
Entered.....	:	:	:	:	:	:	:	:	V	V
PP3c Solutions List	:	:	:	:	:	:	:	:	:	:
Omitted.....	V	V	V	V	V	V	V	V	V	V
Entered.....	:	:	:	:	:	:	:	:	:	:
PP3d Networks + Images Selection	:	:	:	:	:	:	:	:	:	:
Omitted.....	V	V	V	:	:	V	V	V	:	V
ID - Name.....	:	:	:	V	V	:	:	:	:	V
- Index.....	:	:	:	:	:	:	:	:	V	V
Image - Default.....	:	:	:	V	:	:	:	:	:	V
- INPUT.....	:	:	:	V	V	:	:	:	V	V
- 1ST.....	:	:	:	:	:	:	:	:	:	V
- 2ND.....	:	:	:	:	:	:	:	:	:	V
- 3RD.....	:	:	:	:	:	:	:	:	:	V
PP3e Array Type	:	:	:	:	:	:	:	:	:	:
Omitted.....	V	V	V	V	V	V	V	V	V	V
Default (COLUMNS).....	:	:	:	:	:	:	:	:	:	:
COLUMNS.....	:	:	:	:	:	:	:	:	:	:
ROWS.....	:	:	:	:	:	:	:	:	:	B
Default (CONTROL-PTS).....	:	:	:	:	:	:	:	:	:	:
CONTROL-POINTS.....	:	:	:	:	:	:	:	:	:	:
GRID-POINTS.....	:	:	:	:	:	:	:	:	:	B
PP4a Configuration Data Identifier	:	:	:	:	:	:	:	:	:	:
Omitted.....	:	:	:	:	:	:	:	:	:	:
Entered.....	V	V	V	V	V	V	V	V	V	V
PP4b Case Selection	:	:	:	:	:	:	:	:	:	:
Omitted.....	V	V	V	V	V	V	V	V	:	V
Entered.....	:	:	:	:	:	:	:	:	V	V
PP4c Solutions List	:	:	:	:	:	:	:	:	:	:
Omitted.....	V	V	V	V	V	V	V	V	V	V
Entered.....	:	:	:	:	:	:	:	:	:	:

(V implies Validated, B implies known bug)

Table 1. continued.

PANAIR option	SAMPLE TEST CASE NUMBER									EV	
	1	2	3	4	5	6	7	8	9		
PP4d Networks + Images Selection											
Omitted.....	V	V	V				V	V		V	
ID - Name.....				V	V	V				V	
ID - Index.....									V	V	
Image - Default.....				V						V	
- INPUT.....				V	V	V			V	V	
- 1ST.....										V	
- 2ND.....										V	
- 3RD.....										V	
PANELS.....				V	V	V				V	
COLSUM.....											

(V implies Validated, B implies known bug)

Table 1. concluded.

1. EIGHT PANEL DELTA WING

Purpose

The purposes of this case are to check that all PAN AIR modules execute and to check for certain self-consistencies. This case is intended to be the first case executed whenever PAN AIR is installed on a new computer system.

Configuration, Flow, and Modeling

The geometry of the wing is illustrated in figure 1.1. It is a 5 percent thick delta wing. The Mach number is 2.0, and the compressibility direction corresponds to zero angle of attack. The boundary conditions are the standard indirect specification of impermeability for a thick configuration (i.e., class 1, subclasses 1 and 2). Three solutions are obtained, corresponding to angles of attack of 0° and $\pm 5.7295^\circ$.

Several results should follow from the symmetry of the configuration. First, for $\alpha = 0^\circ$, the flow properties for the upper surface should have the same magnitude as corresponding points on the lower surface. Second, the flow properties on the upper surface for $\alpha = +5.7295^\circ$ should be equal in magnitude to the flow properties at corresponding points on the lower surface for $\alpha = -5.7295^\circ$, and vice-versa.

Input

The input is given in figure 1.2. Several items are worth noting.

Global Data: There is only one plane of stated geometric symmetry, even though the configuration actually has two symmetry planes. Also, there is one plane of flow symmetry.

Network Data: The top surface of the wing is the RIGHT-TOP-WING network and the bottom surface of the wing is called the RIGHT-BOT-WING network. The input ordering of the network grid point coordinates causes the normal vectors for both wing networks to point nominally in the $-z_0$ direction. Thus the appropriate boundary condition for the RIGHT-TOP-WING network is zero mass flux on the network's "lower" surface, while for the RIGHT-BOT-WING network the appropriate boundary condition is zero mass flux on the network's "upper" surface.

Geometric Edge Matching Data: This data group is used to specify network edge abutments. Since no data is supplied for this case PAN AIR will search for all the abutments. Because the default value of zero is being used for the edge matching tolerance (record G7), there must be no geometric gaps between abutting networks in order for PAN AIR to correctly identify the abutments. In this case this condition is satisfied by the input grid point coordinates. In general, however, it would be better to specify a small positive value for the tolerance. Regardless of the choice made by the user, the abutment list printed by the DQG module of PAN AIR should always be checked to see that the abutments are as the user intended.

PDP Data: There are two surface flow properties cases. In the first case, only solution number 2 ($\alpha = 0^\circ$) is requested, and flow properties are requested for the input networks only (i.e., properties on the image networks are not requested). For the second case, all solutions are requested (by default) and data are requested for both the input configuration and its image. For each case, all quantities are to be stored on the PDP data base for a run of the PPP (Print/Plot Processor) module.

CDP Data: There is one case for forces and moments, with the accumulation of forces and moments for the configuration being the forces and moments computed using the isentropic pressure coefficient formula. Note that, since there is only one CDP case, accumulation serves no purpose other than just the testing the part of the code involved with this option.

PPP Data: Generation of three plot files is requested. All use the default options for selecting which data to put into the files. One file will contain the network grid point coordinates, one will contain the flow properties data for the two cases specified, and one will contain the force and moment data for the one case specified.

Results and Discussion

Figure 1.3 gives sample results for flow properties at the first panel center control point (refined grid index number (2,2)) for both the top and bottom wing networks. Observe that the expected symmetry/antisymmetry properties hold true, except for an occasional one digit in the last place (underlined in figure). This very slight asymmetry is due to the fact that at the leading edge abutment of the two wing networks an aerodynamic boundary condition is applied to one network, while a doublet matching condition is applied to the other.

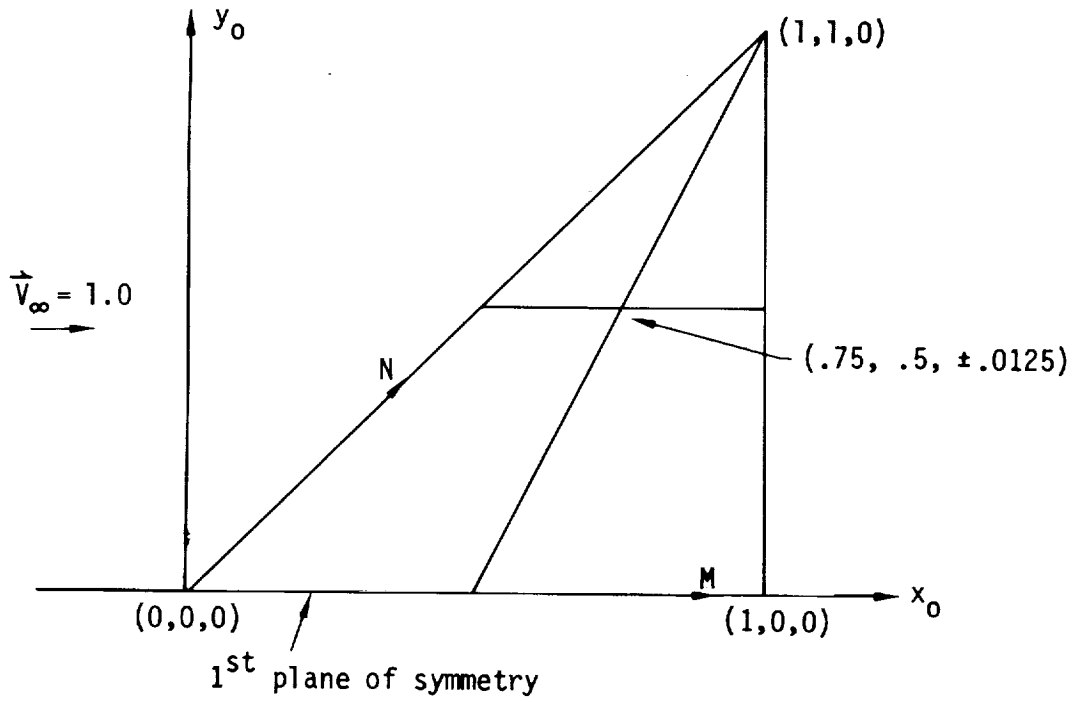

a. Plan view

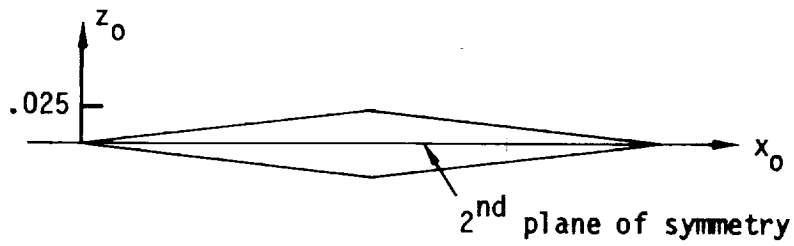

b. Cross-section at $y_0 = 0$

Figure 1.1 Geometry of eight panel delta wing

```

// PAN AIR CASE MANUAL CASE 1
// 2 NETWORK, 8 PANEL DELTA WING, WITH 1 PLANE OF SYMMETRY
// PLUS WAKE NETWORK
// SUPERSONIC FLOW, MACH NUMBER 2.0
// START GLOBAL DATA GROUP
BEGIN GLOBAL DATA /G1
PID = SIMPLE DELTA WING WITH THICKNESS, ONE PLANE OF SYMMETRY
UID=USER IDENTIFICATION
// DEFAULT RECORD G4
// ONE PLANE OF CONFIGURATION SYMMETRY (X-Z PLANE)
// NORMAL VECTOR IS Y-AXIS
// SYMMETRIC-FLOW (BETA MUST BE ZERO)
MACH = 2.0 CALPHA = 0. CBETA = 0. /G5
// USE DEFAULTS FOR ALL SOLUTION DATA EXCEPT ALPHA AND SOLUTION-ID
// (BETA = 0., UINF = 1., WM = 0. FOR ALL SOLUTIONS)
ALPHA = -.57295, .0, .57295 /G6.1
SID = SOLN-1, SOLN-2, SOLN-3 /G6.2
PRESSURE COEF RULES = ISEN SECOND /G12
CHECKOUT PRINTS = DIP 1 2 3, DQG 1 2 4 5 6 /G17
// START NETWORK DATA GROUP
BEGIN NETWORK DATA /N1
// FOR THE NETWORKS --
// NORMAL VECTORS POINT (NOMINALLY) DOWNWARD
// NETWORK LOWER SURFACE EXPOSED TO EXTERNAL FLOW FIELD FOR 1ST NETWORK.
// NETWORK UPPER SURFACE EXPOSED TO EXTERNAL FLOW FIELD FOR 2ND NETWORK.
// NETWORK EDGE 1-LEADING EDGE
// NETWORK EDGE 2-COLLAPSED WING TIP OR OUTBOARD EDGE OF WAKE
// NETWORK EDGE 3-TRAILING EDGE
// NETWORK EDGE 4-INBOARD EDGE
NETWORK = RIGHT-TOP-WING, 3 3 NEW
0.0000E-01 0.0000E-01 0.0000E-01 5.0000E-01 0.0000E-01 2.5000E-02
1.0000E+00 0.0000E-01 0.0000E-01 5.0000E-01 5.0000E-01 0.0000E-01
7.5000E-01 5.0000E-01 1.2500E-02 1.0000E+00 5.0000E-01 0.0000E-01
1.0000E+00 1.0000E+00 0.0000E-01 1.0000E+00 1.0000E+00 0.0000E-01
1.0000E+00 1.0000E+00 0.0000E-01
BOUNDARY CONDITION= 1, LOWER /N9
NETWORK = RIGHT-BOT-WING, 3 3 NEW
0.0000E-00 0.0000E-01 0.0000E-01 5.0000E-01 0.0000E-01 -2.500E-02
1.0000E+00 0.0000E-01 0.0000E-01 5.0000E-01 5.0000E-01 0.0000E-01
7.5000E-01 5.0000E-01 -1.2500E-02 1.0000E+00 5.0000E-01 0.0000E-01
1.0000E+00 1.0000E+00 0.0000E-01 1.0000E+00 1.0000E+00 0.0000E-01
1.0000E+00 1.0000E+00 0.0000E-01
BOUNDARY CONDITION= 1, UPPER /N9
NETWORK = RIGHT-WAKE, 2 3 NEW
1.0000E+00 0.0000E-01 0.0000E-01 5.0000E+00 0.0000E-01 0.0000E-01
1.0000E+00 5.0000E-01 0.0000E-01 5.0000E+00 5.0000E-01 0.0000E-01
1.0000E+00 1.0000E+00 0.0000E-01 5.0000E+00 1.0000E+00 0.0000E-01
BOUNDARY CONDITION= 1 WAKE 1 /N9

```

Figure 1.2. Input for case 1.

```

//
// OMIT GEOMETRIC EDGE MATCHING DATA GROUP
//
// START FLOW PROPERTIES DATA GROUP
BEGIN FLOW PROPERTIES DATA /FP1
// *****
// ** START SURFACE FLOW PROPERTIES DATA SUBGROUP: PDP DATA **
// *****
// SURFACE FLOW PROPERTIES CASE 1
SURFACE FLOW PROPERTIES=ZERO-ALPHA /SF1
NETWORKS-IMAGES = 1, INPUT = 2, INPUT /SF2
SOLUTIONS = 2 /SF3
POINTS = ALL /SF4A
SURFACES = UPPER, LOWER /SF5
PRINTOUT = ALL /SF10A
DATA BASE = ALL /SF11A
// SURFACE FLOW PROPERTIES CASE 2
SURFACE FLOW PROPERTIES=ALPHA-VARIATION-SF /SF1
NETWORKS-IMAGES = 1, INPUT, 1ST = 2, INPUT, 1ST /SF2
// OMIT RECORD SF3, DEFAULT IS ALL SOLUTIONS
POINTS = CENTER /SF4A-DEFAULT
SURFACES = UPPER, LOWER /SF5
PRINTOUT = ALL /SF10A
DATA BASE = ALL /SF11A
//
// *****
// ** START FORCES AND MOMENTS DATA SUBGROUP: CDP DATA **
// *****
FORCES AND MOMENTS /FM1
SOLUTIONS = 1, 2, 3 /FM4-DEFAULT
PRINTOUT = ALL /FM5
DATA BASE = ALL /FM6
// FORCES AND MOMENTS CASE 1
CASE = ALPHA-VARIATION-FM /FM7
NETWORKS-IMAGES = 1, INPUT = 2, INPUT /FM8
SURFACES = UPLO /FM12
// INCLUDE THIS CASE IN THE ACCUMULATION CASE,
// AND SELECT ONE PRESSURE COEFFICIENT RULE
ACCUMULATE = ISENTROPIC /FM21
//
// START PRINT PLOT DATA GROUP
BEGIN PRINT PLOT DATA /PP1
GEOMETRY DATA /PP2A
POINT DATA /PP3A
CONFIGURATION DATA /PP4A
END PROBLEM DEFINITION

```

Figure 1.2. Concluded.

ITEM	α	NETWORK, IMAGE			
		1, input	1, 1st	2, input	2, 1st
VX (x ₀ component of velocity)	-0.57295°	.95356	.95356	.96688	.96688
	0°	.96027	.96027	.96027	.96027
	+0.57295°	.96688	.96688	.95356	.95356
VY (y ₀ component of velocity)	-0.57295°	.04020	-.04020	.03046	-.03046
	0°	.03533	-.03533	.03533	-.03533
	+0.57295°	.03046	-.03046	.04020	-.04020
VZ (z ₀ component of velocity)	-0.57295°	.05490	.05490	-.05338	-.05338
	0°	.05414	.05414	-.05414	-.05414
	+0.57295°	.05338	.05338	-.05490	-.05490
WMAG (mass flux magnitude)	-0.57295°	1.14115	1.14115	1.10088	1.10088
	0°	1.12106	1.12106	1.12106	1.12106
	+0.57295°	1.10087	1.10087	1.14114	1.14114
CPISEN (isentropic pressure)	-0.57295°	.09376	.09376	.06523	.06523
	0°	.07930	.07930	.07930	.07930
	+0.57295°	.06522	.06522	.09376	.09376

Figure 1.3. Results on wetted side of (2,2) control points for case 1.

2. THIN RECTANGULAR WING

Purpose

The purpose of this case is to further test the self-consistency of PAN AIR. A simple flat plate rectangular wing is run with a variety of input options which should yield approximately the same results. The consistency of results is being checked, rather than accuracy. This case also illustrates how to set up input data for local incremental flows, rotational flows, and specified mass flux. Due to the numerous options illustrated, this case is one of the most complicated in this manual.

Configuration, Flow, and Modeling

The configuration is a planar rectangular plate with an aspect ratio of 20, and is illustrated in figure 2.1. Two doublet wing networks are defined. The purpose of the outboard network is to provide a sufficiently large aspect ratio to simulate a two-dimensional flat plate*. In addition, standard (type DW1) wake networks of length 99 are attached to the trailing edge of both wing networks. The spanwise paneling of each wake is identical to that

* Editor's note: This case was designed prior to the realization that there exists a more efficient and accurate technique for analyzing two-dimensional flows. In this technique, a DW1 network replaces the outboard wing network, and a DW2 network replaces the wake trailing behind the outboard network. The control point edge of the DW1 network must abut the outboard edge of the wing. Also, the spanwise extent of the outboard network may be significantly increased. This modeling technique reduces the number of unknown singularity parameters. It also prevents shed vorticity from occurring on the outboard network, thereby creating a flow field that is much more two-dimensional.

of its upstream wing network. The angle of attack is 5.7392° , which is simulated by the following four different flow models:

- (a) a uniform freestream flow meeting the wing with angle of attack $\alpha = 5.7392^\circ$ (≈ 0.1 radian),
- (b) a uniform freestream at zero α , plus a specified flow of 0.1 units in the negative z_0 direction,
- (c) a uniform freestream at zero α , plus a local onset flow in the positive z_0 direction with magnitude of 0.1, and
- (d) a uniform freestream at zero α , supplemented by a rotational onset flow (about the distant point (100,0,0)) that gives a z_0 component of velocity of approximately 0.1 units over the wing networks.

The four different flow models used to simulate $\alpha = 0.1$ radian are all specified with class 2, subclass 3 boundary conditions, namely,

$$\sigma = 0 \quad (\text{no sources}) \quad (2.1)$$

$$\vec{w}_A \cdot \hat{n} = -\vec{U}_0 \cdot \hat{n} + \beta_{n2} \quad (2.2)$$

In these equations

1. \vec{U}_0 is the total onset flow, i.e., the sum of uniform (\vec{U}_∞), local incremental (\vec{U}_{loc}), and rotational (\vec{U}_{rot}) onset flows (see equations B.2.5 of the User's Manual).
2. β_{n2} is the specified (total mass flux) flow, see section B.3.2 of the User's Manual.

The onset flows and specified flow are chosen so that for each of the four flow models used to simulate $\alpha = 0.1$ radian, the right hand side of equation (2.2) becomes 0.1.

The flow and geometry exhibit symmetry about the x_0-z_0 plane. Standard wake boundary conditions (i.e., class 1, subclass 4) are used for the wake networks.

Input

The four models are illustrated in figure 2.2, and the input listing appears in figure 2.3. The input order chosen for the network grid points results in unit normals pointing in the negative z direction. Thus the network's "upper" surfaces correspond to the bottom side of the wing. The class 2, subclass 3 boundary condition to be used is specified on record N9.

In model (a) the uniform onset flow meets the wing networks at an angle of attack $\alpha = 5.7392^\circ$, as shown in figure 2.2 (a). This angle is specified by the first set of data listed under record G6 (i.e., the data identified as SID=ALPHA-VARIATION). For this model, the network is treated as an impermeable surface, i.e., $\vec{W}_A \cdot \hat{n} = -\vec{U}_\infty \cdot \hat{n}$, so $\beta_{n2} = 0.0$ in equation (2.2). Normally, values for mass flux are specified by using record set N17. Zero flux, however, is the default, so record set N17 is omitted for solution 1 (model (a)).

Model (b) simulates the angle of attack with a specified flow (in this case downwash) as illustrated in figure 2.2b. Several features should be noted:

1. The uniform onset flow \vec{U}_∞ is parallel to the wing networks, and α is accordingly set equal to zero (the second set of solution data listed under record G6). Consequently, $\vec{U}_0 \cdot \hat{n} = 0$ and equation (2.2) becomes $\vec{W}_A \cdot \hat{n} = \beta_{n2}$.

2. The doublet network is required to produce a specified flow of $\beta_{n2} = 0.1$ units to turn the freestream flow downward through the angle α , thereby simulating the desired angle of attack. This is a simple example of the more general case of a thin cambered surface discussed in section B.3.2 of the User's Manual (see equation B.3.28 therein).
3. The specified flow β_{n2} is input using record set N17 for both wing networks. Looking at the listing, TERM=2 tells PAN AIR that the second equation is being specified, and SOLUTIONS = 2 tells PAN AIR that this specified flow applies only to the second set of data listed under record G6.

For model (c), figure 2.2 (c), the uniform onset flow \vec{U}_∞ is again parallel to the wing networks and so $\alpha = 0$. (third set of solution data listed under record G6). The wing is made to see the angle of attack by vectorially adding the local onset flow $\vec{U}_{loc} = (0,0,.1)$ to \vec{U}_∞ to obtain the total onset flow $\vec{U}_0 = (1, 0, 0.1)$. This is accomplished by using record set N18 for both wing networks. The resulting boundary condition is

$$\vec{w}_A \cdot \hat{n} = -(\vec{U}_\infty + \vec{U}_{loc}) \cdot \hat{n} = 0.1$$

(since $\beta_{n2} = 0.0$ by default) as required. Also associated with model (c) are records G16 and SF7. Record G16 tells PAN AIR to save the local onset flow so it can be used to calculate the pressure in the second flow properties case, where SF7 appears. The local onset flow affects both ΔE (eq. B.4.13 in the User's Manual) and the total velocity, V (fig. B.48 in the User's Manual). The local onset flow is also used in the second forces and moments case, as specified by record FM14.

Note that the incremental onset flow is only included in the second flow properties case (labeled "TOTAL-ONSET-FLOW"), since in the first case (labeled "ALL-FLOWS"), the default pressure computation option of "UNIFORM-ONSET-FLOW" is chosen. See section B.4 of the User's Manual for a further discussion of the effects of these options. The incremental onset flow is treated similarly in the two forces and moments cases.

Model (d) is nearly the same as model (c), but instead of specifying a uniform local upwash \vec{U}_{loc} , a nearly uniform upwash \vec{U}_{rot} is defined as shown in figure 2.2(d). The rotational flow about a line parallel to the y_0 axis, at the point (100.,0,0), with clockwise angular velocity of magnitude 0.001 radians/second is input on the fourth set of solution data listed under record G6. Again, $\alpha = 0$ is specified. The resulting boundary condition at the wing networks is

$$\vec{w}_A \cdot \hat{n} = -(\vec{U}_\infty + \vec{U}_{rot}) \cdot \hat{n} = 0.1 - 0.001x_0 \cong 0.1$$

As in the case of model (c), the presence of record SF7 in the second flow properties case and record FM14 in the second forces and moments case results in the total onset flow $\vec{U}_0 = \vec{U}_\infty + \vec{U}_{rot}$ being used to calculate the pressure coefficients and overall forces and moments.

Note that edge forces are requested (record FM9).

Results and Discussion

Figure 2.4 shows the values of various computed quantities for the four solutions. This figure illustrates that models (a)-(c) produce identical perturbation velocities and doublet strengths at point (2,2), but that model (d) produces slightly different results. This was to be expected, since the boundary conditions were identical for models (a)-(c), while the boundary conditions for model (d) varied only slightly. Note that the x_0 components of the perturbation velocities are nearly equal in magnitude to the freestream speed because the control point is very close to the leading edge. However, the pressure coefficients vary noticeably among the four solutions. These variations are expected due to the differing uniform and total onset flows. Note also that the x_0 component of force in the wind axis system for model (a) differs significantly from the x_0 components for the other models. This is because the wind axes for models (b)-(c) are identical to the reference axes since the real α (as opposed to the simulated α) is zero. Consequently, models (b)-(d) exhibit totally inaccurate x_0 components of force in the wing axis system.

The forces in figure 2.4 include the edge suction force. Since the wing lies strictly in the $z_0=0$ plane, the x_0 force components in the reference coordinate system arise only from the edge force, the computation of which was requested by record FM9. The drag (i.e., the x_0 component in the wind axis system) is very nearly zero as it should be since the flow is very nearly two dimensional.

The forces shown in figure 2.4 are those computed using the isentropic pressure formula and have been made nondimensional by dividing them by the area of network 1 (i.e., the numbers in figure 2.4 were obtained from the CDP printout by dividing by 10, which is the area of network 1).

In summary, the results for this case are self-consistent where self-consistency is to be expected. However, program users taking advantage of non-standard options should be aware of the effect that these options have on the computation of surface velocities, pressure coefficients, in-plane forces (edge forces), and moments arising from in-plane forces.

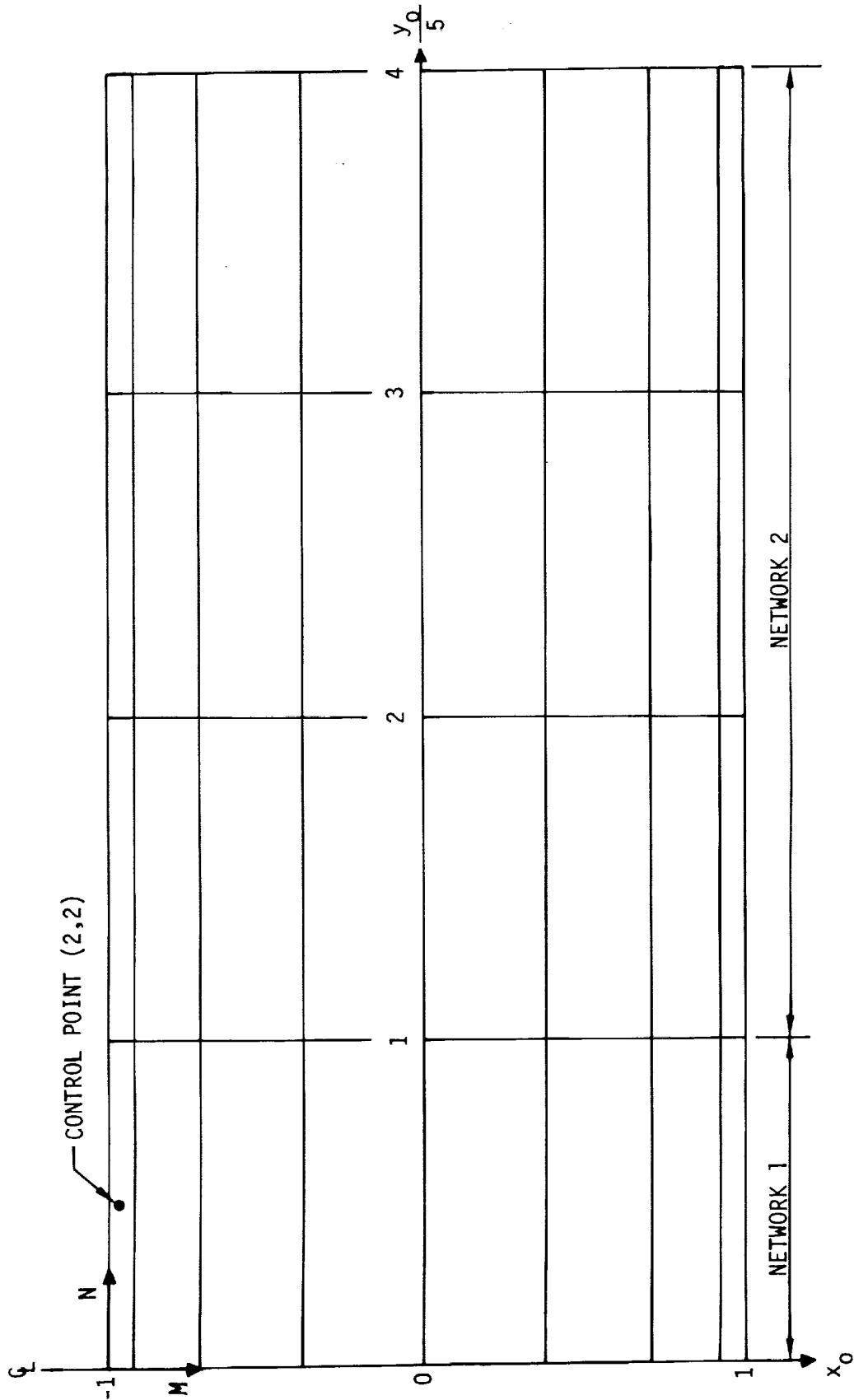
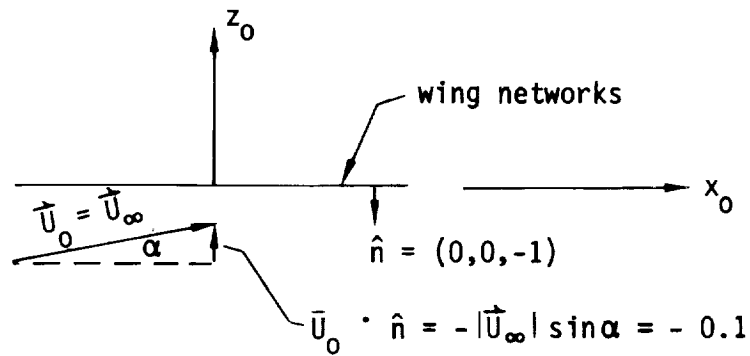
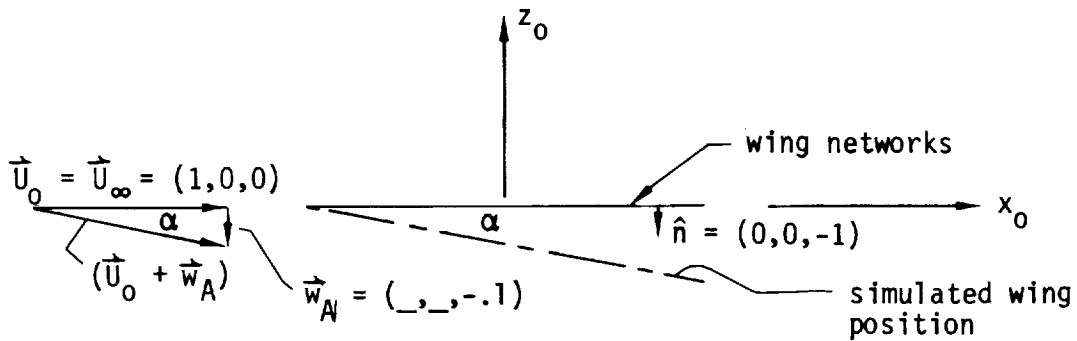

Figure 2.1 - Thin rectangular wing networks; the bottom of the wing ($z_0=0$) corresponds to the "upper" surfaces of the networks.



- a. Uniform onset flow \vec{U}_∞ at angle $\alpha = \text{ALPHA} = 5.7392^\circ$ to wing



- b. Uniform onset flow \vec{U}_∞ parallel to wing networks plus specified flow (downwash) of amount $\beta_{n2} = \vec{w}_A \cdot \hat{n} = 0.1$ at wing networks

Figure 2.2 - Four different models used to simulate a 5.7392° angle of attack; $|\vec{U}_\infty| = 1$.

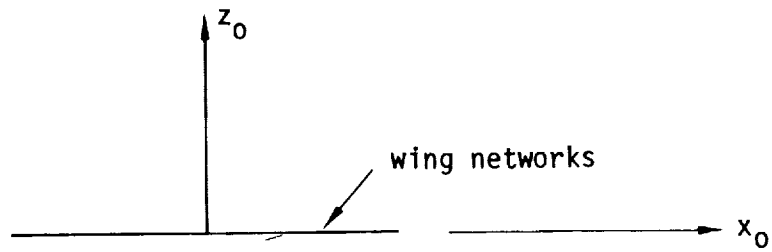

$$\vec{U}_0 = \vec{U}_\infty + \vec{U}_{loc}$$

$$\vec{U}_{loc} = (0, 0, .1)$$

- c. Uniform onset flow \vec{U}_∞ parallel to wing plus local onset flow $\vec{U}_{loc} = (0, 0, .1)$ on wing networks

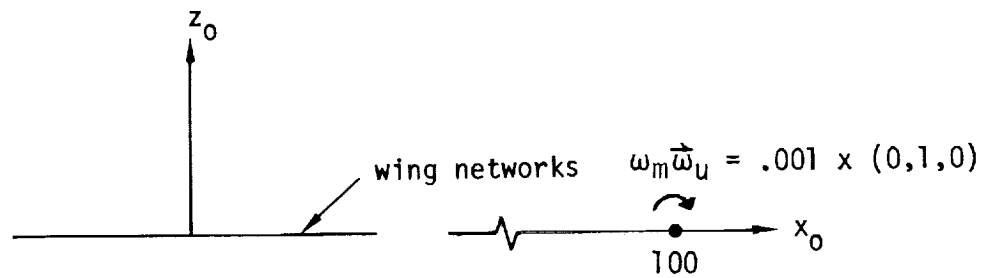

$$\vec{U}_0 = \vec{U}_\infty + \vec{U}_{rot}$$

$$\vec{U}_{rot} = (0, 0, .1 - .001x_0)$$

- d. Uniform onset flow \vec{U}_∞ parallel to wing networks plus rotational onset flow $\vec{U}_{rot} = (0, .001, 0) \times \vec{R}$

```

// PAN AIR CASE MANUAL CASE 2
// FLAT TWO-DIMENSIONAL RECTANGULAR WING (ASPECT RATIO = 20)
// SUBSONIC FLOW, MACH NUMBER 0.6
// SOLUTION 1 = ALPHA (SINE(ALPHA)=.1000) - MODEL A.
// SOLUTION 2 = SPECIFIED FLOW (RECORD SET N17) - MODEL B.
// SOLUTION 3 = TOTAL (LOCAL) ONSET FLOW (RECORD SET N18) - MODEL C.
// SOLUTION 4 = ROTATIONAL ONSET FLOW - MODEL D.
// START GLOBAL DATA GROUP
BEGIN GLOBAL DATA /G1
PID=FLAT TWO-DIMENSIONAL RECTANGULAR WING (ASPECT RATIO = 20)
UID=USER IDENTIFICATION
// OMIT RECORD G4, DEFAULT IS ONE PLANE OF CONFIGURATION AND FLOW SYMMETRY
MACH = 0.6 /G5
ALPHA UINF WM WDC WCP SID /G6, OPTION 1
5.7392 1. 0. 0. 1. 0., 0. 0. 0., ALPHA-VARIATION
0. 1. 0. 0. 1. 0., 0. 0. 0., SPECIFIED-FLOW
0. 1. 0. 0. 1. 0., 0. 0. 0., LOCAL-ONSET-FLOW
0. 1. .001 0. 1. 0., 100. 0. 0., ROTATIONAL-FLOW
TOLERANCE=.001 /G7
SURFACE SELECTION=UPPER,LOWER,UPLO /G8
PRESSURE COEF RULES=ISENTROPIC,LINEAR,SECOND-ORDER /G12
// STORE LOCAL ONSET FLOW, FOR USE IN PRESSURE COEFFICIENT CALCULATIONS
STORE LOCAL ONSET FLOW /G16
CHECKOUT PRINTS = ALL /G17
// END OF GLOBAL DATA GROUP
//
// START NETWORK DATA GROUP
BEGIN NETWORK DATA /N1
// START DATA FOR NETWORK A1
NETWORK=A1, 9, 2, NEW /N2A
-1.0000 0. 0. -.9239 0. 0.
-.7071 0. 0. -.3827 0. 0.
0. 0. 0. .3827 0. 0.
.7071 0. 0. .9239 0. 0.
1.0000 0. 0.
-1.0000 5. 0. -.9239 5. 0.
-.7071 5. 0. -.3827 5. 0.
0. 5. 0. .3827 5. 0.
.7071 5. 0. .9239 5. 0.
1.0000 5. 0.
// NORMAL VECTOR POINTS DOWNWARD (-Z DIRECTION)
// NETWORK EDGE 1-LEADING EDGE
// NETWORK EDGE 2-OUTBOARD EDGE
// NETWORK EDGE 3-TRAILING EDGE
// NETWORK EDGE 4-INBOARD EDGE (IN PLANE OF SYMMETRY)
BOUNDARY CONDITION=2,3 /N9

```

Figure 2.3 - Input for case 2

```

SPECIFIED FLOW FOR MODEL (B)           /N17A
TERM=2                                 /N17B
INPUT-IMAGES=INPUT,1ST                 /N17C
SOLUTIONS=2                             /N17D
POINTS=ALL $ 0.10                       /N17E,F
LOCAL ONSET FLOW FOR MODEL (C)         /N18A
TERM=VXYZ                                /N18B
INPUT-IMAGES=INPUT,1ST                 /N18C
SOLUTIONS=3                             /N18D
POINTS=ALL $ 0.,0.,.10                  /N18E,F
// END OF DATA FOR NETWORK A1
// START DATA FOR NETWORK A2
NETWORK=A2, 9, 4, NEW /N2A
-1.0000  5.      0.      -.9239  5.      0.
-.70710  5.      0.      -.3827  5.      0.
0.        5.      0.      .3827   5.      0.
.7071    5.      0.      .9239   5.      0.
1.0000   5.      0.
-1.0000  10.     0.      -.9239  10.     0.
-.7071   10.     0.      -.3827  10.     0.
0.        10.     0.      .3827   10.     0.
.7071    10.     0.      .9239   10.     0.
1.0000   10.     0.
-1.0000  15.     0.      -.9239  15.     0.
-.70710  15.     0.      -.3827  15.     0.
0.        15.     0.      .3827   15.     0.
.7071    15.     0.      .9239   15.     0.
1.0000   15.     0.
-1.0000  20.     0.      -.9239  20.     0.
-.70710  20.     0.      -.3827  20.     0.
0.        20.     0.      .3827   20.     0.
.7071    20.     0.      .9239   20.     0.
1.0000   20.     0.
// SAME EDGE ARRANGEMENT AS NETWORK A1
BOUNDARY CONDITION=2,3                 /N9
SPECIFIED FLOW FOR MODEL (B)           /N17A
TERM=2                                 /N17B
INPUT-IMAGES=INPUT,1ST                 /N17C
SOLUTIONS=2                             /N17D
POINTS=ALL $ 0.10                       /N17E,F
LOCAL ONSET FLOW FOR MODEL (C)         /N18A
TERM=VXYZ                                /N18B
INPUT-IMAGES=INPUT,1ST                 /N18C
SOLUTIONS=3                             /N18D
POINTS=ALL $ 0.,0.,.10                  /N18E,F
// END OF DATA FOR NETWORK A2

```

Figure 2.3 - Continued.

```

// START DATA FOR NETWORK W1
NETWORK=W1, 2, 2, NEW /N2A
1.      0.      0.      100.     0.      0.
1.      5.      0.      100.     5.      0.
// SAME EDGE ARRANGEMENT AS NETWORK A1
BOUNDARY CONDITION=1,4 /N9
// END OF DATA FOR NETWORK W1
// START DATA FOR NETWORK W2
NETWORK=W2, 2, 4, NEW /N2A
1.      5.      0.      100.     5.      0.
1.     10.      0.      100.    10.      0.
1.     15.      0.      100.    15.      0.
1.     20.      0.      100.    20.      0.
// SAME EDGE ARRANGEMENT AS NETWORK A1
BOUNDARY CONDITION=1,4 /N9
// END OF DATA FOR NETWORK W2
// END OF NETWORK DATA GROUP
// OMIT GEOMETRIC EDGE MATCHING DATA GROUP
//
// START FLOW PROPERTIES DATA GROUP
BEGIN FLOW PROPERTIES DATA /FP1
//
// START SURFACE FLOW PROPERTIES DATA SUBGROUP
//
// SURFACE FLOW PROPERTIES CASE 1
SURFACE FLOW PROP=ALL-FLOWS /SF1
NETWORKS-IMAGES=A1 /SF2
// OMIT RECORD SF3, DEFAULT IS ALL SOLUTIONS
POINTS=ALL /SF4A
PRINTOUT=ALL /SF10A
DATA BASE = ALL /SF11A
//
// SURFACE FLOW PROPERTIES CASE 2
SURFACE FLOW PROP=TOTAL-ONSET-FLOW /SF1
NETWORKS-IMAGES=A1 /SF2
SOLUTIONS=3,4 /SF3
POINTS=CENTER /SF4A-DEFAULT
// INCLUDE LOCAL (SOLUTION 3) AND ROTATIONAL (SOLUTION 4) ONSET FLOWS
// IN PRESSURE COEFFICIENT CALCULATIONS
COMPUTATION OPTION FOR PRESSURES=TOTAL-ONSET-FLOW /SF7
PRINTOUT=ALL /SF10A
DATA BASE = ALL /SF11A
// END OF SURFACE FLOW PROPERTIES DATA SUBGROUP
//

```

Figure 2.3 - Continued.

```

// START FORCES AND MOMENTS DATA SUBGROUP
FORCES AND MOMENTS /FM1
AXIS SYSTEMS = RCS /FM3
SOLUTIONS = 1, 2, 3, 4 /FM4-DEFAULT
//
// FORCES AND MOMENTS CASE 1
CASE = ALL-FLOWS-FM /FM7
NETWORKS-IMAGES = A1 /FM8
EDGE FORCE = A1, 1 /FM9
SURFACE SELECTION = UPLO /FM12
ACCUMULATE = BOUNDARY-CONDITION, NONE, ISENTROPIC /FM21
CASE=TOTAL-ONSET-FLOW-FM /FM7
NETWORKS-IMAGES = A1 /FM8
EDGE FORCE = A1, 1 /FM9
SURFACE SELECTION = UPLO /FM12
COMPUTATION OPTION FOR PRESSURES = TOTAL-ONSET-FLOW /FM14
// END OF FORCES AND MOMENTS DATA SUBGROUP
// END OF FLOW PROPERTIES DATA GROUP
//
// START PRINT-PLOT DATA GROUP
BEGIN PRINT PLOT DATA /PP1
GEOMETRY DATA /PP2A
POINT DATA /PP3A
CONFIGURATION DATA /PP4A
// END OF POINT-PLOT DATA GROUP
END PROBLEM DEFINITION

```

Figure 2.3 - Concluded.

	(a)	(b)	(c)	(d)
	$\alpha=5.7392^\circ$	specified	local	rotational
		flow	onset flow	onset flow
1. uniform onset flow, U^*	0.99499, 0., 0.1	1., 0., 0.	1., 0., 0.	1., 0., 0.
2. specified flow β_{n2}^*	none	0.1	none	none
3. local onset flow, U_{loc}^*	none	none	0., 0., 0.1	none
4. rotational onset flow, U_{rot}^*	none	none	none	0., 0., 0.10096
5. total onset flow $U_0 = U + U_{loc} + U_{rot}$	0.99499, 0., 0.1	1., 0., 0.	1., 0., 0.1	1., 0., 0.10096
6. bottom surface perturbation velocity, v^*	-0.97550, 0.00006, -0.1	-0.97550, 0.00006, -0.1	-0.97550, 0.00006, -0.1	-0.97549, 0.00006, -0.10096
7. doublet strength*	-0.10467	-0.10467	-0.10467	-0.10469
8. bottom surface total velocity $V = U_0 + v$	0.01948, 0.00006, 0.	0.02450, 0.00006, -0.1	0.02450, 0.00006, 0.	0.02451, 0.00006, 0.
9. bottom surface 2nd order: pressure* via uniform onset flow option (G10)	1.34580	1.33197	1.34197	1.34197
10. bottom surface 2nd order: pressure* via total onset flow option (G10)	1.34580	1.33197	1.35197	1.35216
11. x_0 and z_0 force in ref. coord. system	-0.06730, 0.66411	-0.06730, 0.66536	-0.06730, 0.66626	-0.06734, 0.66268
12. x_0 and z_0 force in wind-cent. coord. sys.	-0.00055, 0.66751	-0.06730, 0.66536	-0.06730, 0.66626	-0.06734, 0.66268

*at control point (2,2) = (-0.96176, 2.48750, 0.0)

Figure 2.4 - Comparison of results for models (a)-(d)

3. WEAPONS CARRIAGE AIRPLANE

Purpose

The purpose of this case is to exercise PAN AIR with a complicated, supersonic configuration that tests numerous program features. In particular, the features being tested included subinclined and superinclined panels, both thick and thin components, a variety of boundary condition types, complicated abutment intersections, complicated doublet matching requirements, and a large number of panels.

Configuration, Flow, and Modeling

The paneling is illustrated in figure 3.1. This configuration was previously analyzed with a version of the PAN AIR pilot code (see INTRODUCTION for references). The analysis is described in references 3.1 and 3.2, and included, in some instances, weapons mounted underneath the aircraft and, therefore, the configuration is referred to as the "weapons carriage airplane" even though no weapon is considered in the present application.

The flowfield Mach number is taken to be 2.0, and the angles of attack considered are 2° and 0° .

Figure 3.2 shows the paneling scheme with the individual networks identified thereon by the index numbers that were assigned by PAN AIR. The wake networks are not shown. Figure 3.3 presents the network abutments in schematic form. Figure 3.3 also gives the correlation between program-assigned network indices and user-assigned network alphanumeric identifiers (e.g., network N11-INLET is network 35). The large number of networks, the curious shapes of some networks, and the multiple networks representing wakes shed from the lifting surfaces resulted from the following constraints:

- (1) Discontinuities in surface slope should correspond to network edges.
- (2) The pilot code requires that network corners (including wake network corners) cannot abut other networks, except at network corners. PAN AIR has less restrictive network abutment rules, but, since a close point-by-point comparison to the pilot code constitutes validation for this case, the pilot code paneling is used. If this restriction were relaxed, the number of networks could be reduced substantially. See figure 16 of reference 3.3 for an example that illustrates the difference between the pilot code and the PAN AIR abutment rules.
- (3) Networks can only abut at their edges.

Note that networks are placed on the nacelle inlet face, nacelle outlet (hereafter referred to as the nacelle base), and the base of the fuselage.

The nacelle inlet face and the nacelle and fuselage surfaces are paneled and boundary conditions are applied thereon so as to attempt to cause the interior flow of the configuration (i.e., flow inside the nacelle and fuselage) to be the undisturbed free stream. The particular boundary conditions used are shown in figure 3.4. Specifying the interior flow to be the undisturbed free stream tends to prevent strong internal flow discontinuities along Mach lines that would, in turn, necessitate dense paneling on the nacelle and fuselage. Note, however, that, because boundary conditions are applied only at a finite number of points on the configuration, the interior flow will not be exactly undisturbed. Refer to section B.3.6.6 of the PAN AIR User's Manual for a more detailed discussion of nacelle modeling.

Input

The input is shown in figure 3.5. Note the following.

The canard, wing, and horizontal tail are idealized as mean camber surfaces (infinitely thin, lifting surfaces). Therefore, the appropriate boundary conditions for them is class 1, subclass 3.

The inlet face is modeled by superinclined panels, which necessarily require two boundary conditions on the downstream side of the face (which is the lower surface by virtue of the input point ordering) and none on the upstream side, as is discussed in section B.3.6.6 of the PAN AIR User's Manual. Note that the flow impinging on the upstream side of any superinclined panel can not be influenced by the panel and that the superinclined panel "swallows" the upstream flow. Since the flow on the downstream side of the face is desired to be the uniform free stream, the appropriate boundary conditions thereon are that (a) the perturbation normal mass flux equal zero, and (b) that the perturbation potential equal zero. These conditions may be satisfied via a class 4 boundary condition specification. In particular, and by reference to figure 7.7 in the PAN AIR User's Manual, it is clear that (a) is satisfied by specifying indices 2 and 3 on record N9 and that (b) is satisfied by specifying indices 6 and 3.

The appropriate boundary conditions for networks defining the nacelle surface and fuselage surface (excluding the bases) are (a) that the outer flow be tangent to the outer surface, and (b) that there be an undisturbed flow at the inner surface. Since the outer surface is the upper surface for all nacelle and fuselage networks, these boundary conditions are conveniently satisfied by specifying class 1, subclass 1 boundary conditions.

Wake networks originate along trailing edges of the configuration. The wake shed from the trailing edge common to the fuselage and nacelle could have been modeled with only one wake network instead of seven (N53-N59), but, as previously mentioned, a point-by-point comparison with the pilot code is desired. Similarly, the wakes shed from the three lifting surfaces could have been modeled with just one network each. Note that even though the wakes shed from the trailing edge of the nacelle and fuselage have no direct upstream influence in supersonic flow, they do have an indirect upstream influence because of the doublet matching conditions enforced by PAN AIR. Therefore, they are required to be there. If they were not there, then the doublet strength matching conditions would cause the doublet strength distribution along the trailing edge of the nacelle and fuselage to equal the distribution of doublet strength on the perimeter of the nacelle and fuselage base networks. This would be an incorrect condition since the latter (as will be discussed in the following paragraph) is ideally zero.

Superinclined networks are placed on the bases of the nacelle and fuselage. These networks can have no direct upstream influence in supersonic flow. Also note that they can have no indirect upstream influence (by virtue of doublet strength matching conditions) since their abutments with the nacelle and fuselage are also abutments with the wake networks shed from the nacelle and fuselage. Therefore, these superinclined networks cannot influence any other part of the configuration. Consequently, they are not required. Note also that the boundary conditions specified for these networks imply an undisturbed freestream flow on the downstream sides of the networks. Thus the singularities thereon would have zero strength if the flow upstream were undisturbed, which is the situation that the modeling is attempting to produce. Since these base networks are not required and, since they ideally would have zero strength, one might question why they are there. They have been left in because the strengths of the singularities thereon are a measure of how close the interior flow really is to the unperturbed freestream. In other words, even though the base networks are not required, they have been left in because their presence provides a measure of the closeness of the interior flow to the undisturbed flow, which, in turn, is one measure of the adequacy of the nacelle and fuselage panelling. If the flow were subsonic, then the base networks would have an upstream influence and, therefore, they would be required. For a more complete discussion of base networks in subsonic flow, see figure 18 of reference 3.3.

The network abutments are completely specified by the input. For example, the line `ABUT=1,2,ENTI=2,4` tells PAN AIR that the entire number 2 edge of network 1 abuts the entire number 4 edge of network 2. Refer to figure 7.3 of the User's Manual for the edge numbering scheme. The record `PLAN=FIRST` tells PAN AIR that the preceding abutment is in the FIRST plane of symmetry (x_0-z_0 plane). Abutments are explicitly specified to reduce the

cost of executing the test case. (The list of abutments was generated from the output of a previous run of this same case, using PAN AIR's automatic abutment search.) The automatic abutment search is turned off by inputting a negative number on the edge matching tolerance record (i.e., on record G7, which is the 17th line in the input).

Recall that this configuration can be modeled with a far fewer number of networks. If this were done, then the automatic abutment search would be far less costly.

Results and Discussion

In regards to the point-by-point comparison of PAN AIR to the pilot code, the singularity strengths, pressure coefficients, forces, and moments show satisfactory agreement considering the somewhat different algorithms that are used. Figure 3.6 compares various force and moment components. For $\alpha=2^\circ$, the PAN AIR overall force and moment coefficients are one to two percent lower than the pilot code coefficients. The individual lifts on the lifting surfaces are likewise in close agreement. FX of the base networks is noted to be only about 1.6 percent of the overall FX. Recall that, if the interior flow were precisely uniform, the singularity strengths on the base networks would be zero, and, hence, there would be no contribution of the base networks to FX. The magnitude of the base FX indicates that the interior flow is satisfactorily smooth, at least immediately upstream of the base. This, in turn, indicates that the paneling arrangement and density may be reasonably accurate for predicting overall forces.

REFERENCES

- 3.1 Cenko, A.; and Tinoco, E. N.: PAN AIR - Weapons, Carriage and Separation. Air Force Flight Dynamics Laboratory Report AFFDL-TR-79-3142, Dec. 1979.
- 3.2 Cenko, A.; Tinoco, E. N.; Dyer, R. D.; and DeJongh, J.: PAN AIR Applications to Weapons Carriage and Separation. Journal of Aircraft, vol. 18, no. 2, Feb. 1981, pp. 128-134.
- 3.3 Carmichael, R. L.; and Erickson, L. L.: PAN AIR - A Higher Order Panel Method for Predicting Subsonic or Supersonic Linear Potential Flows about Arbitrary Configurations. AIAA paper 81-1255, June, 1981.

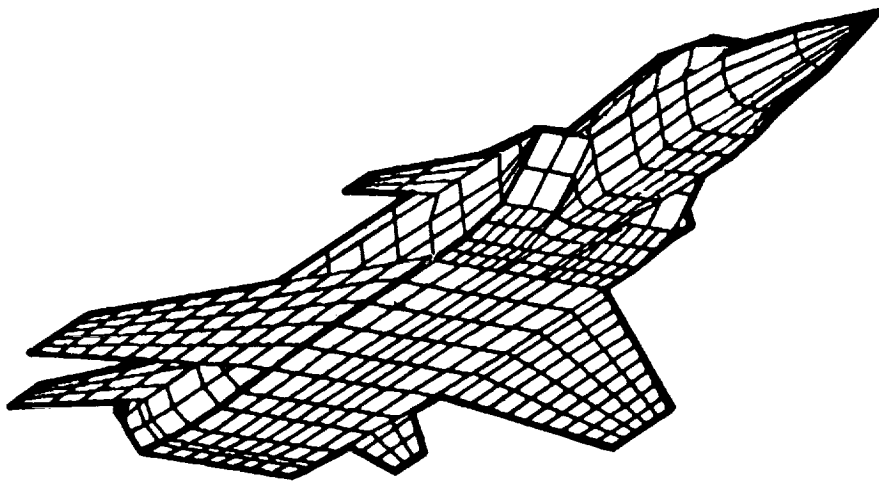
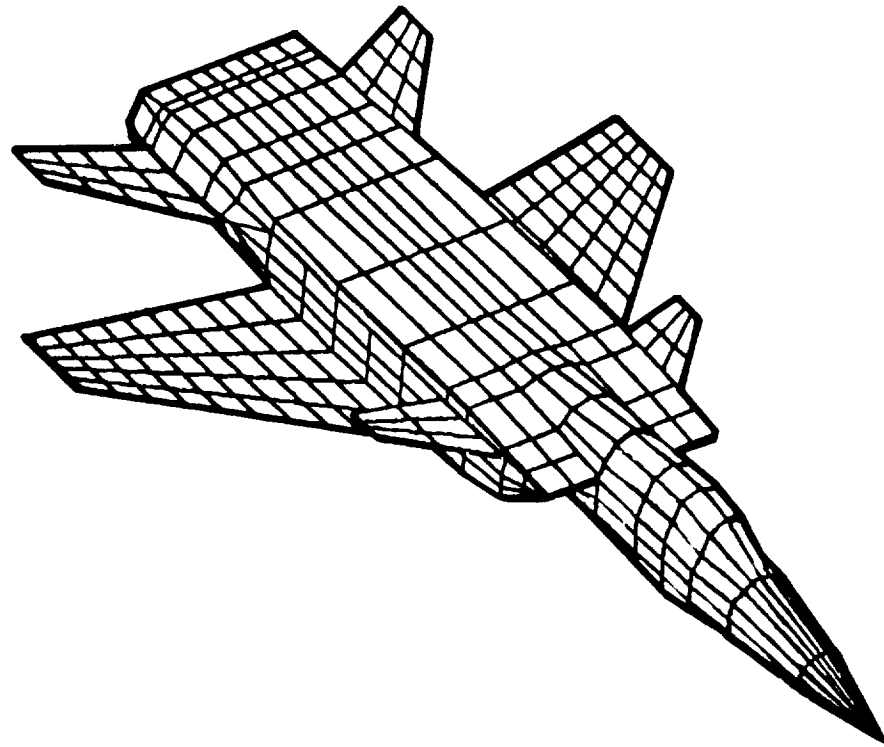

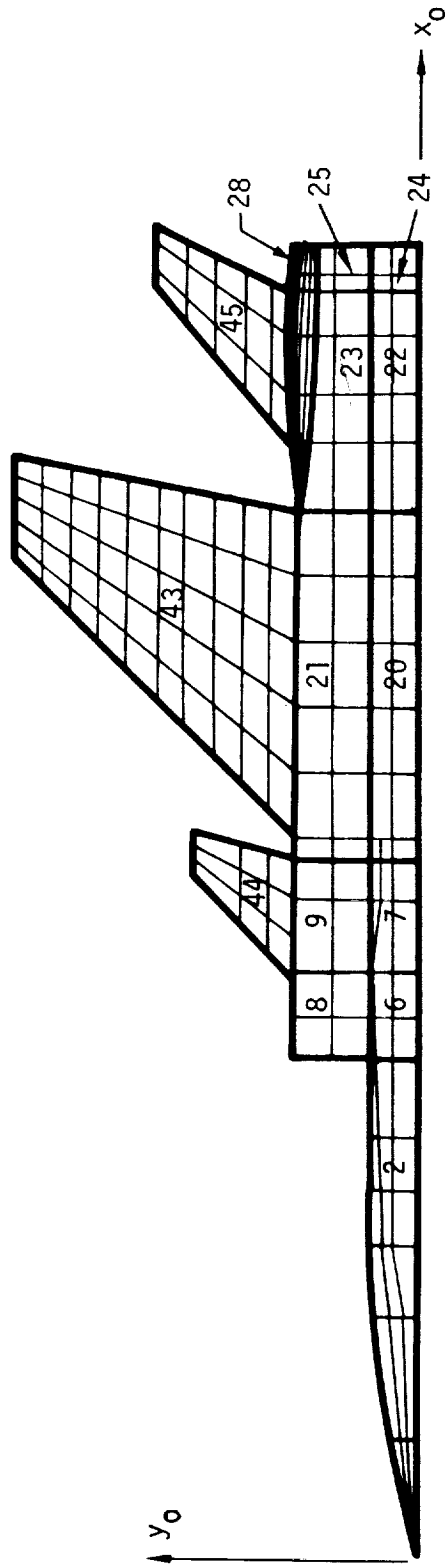

(a) Top View, input networks

Figure 3.2 Weapons carriage aircraft paneling scheme

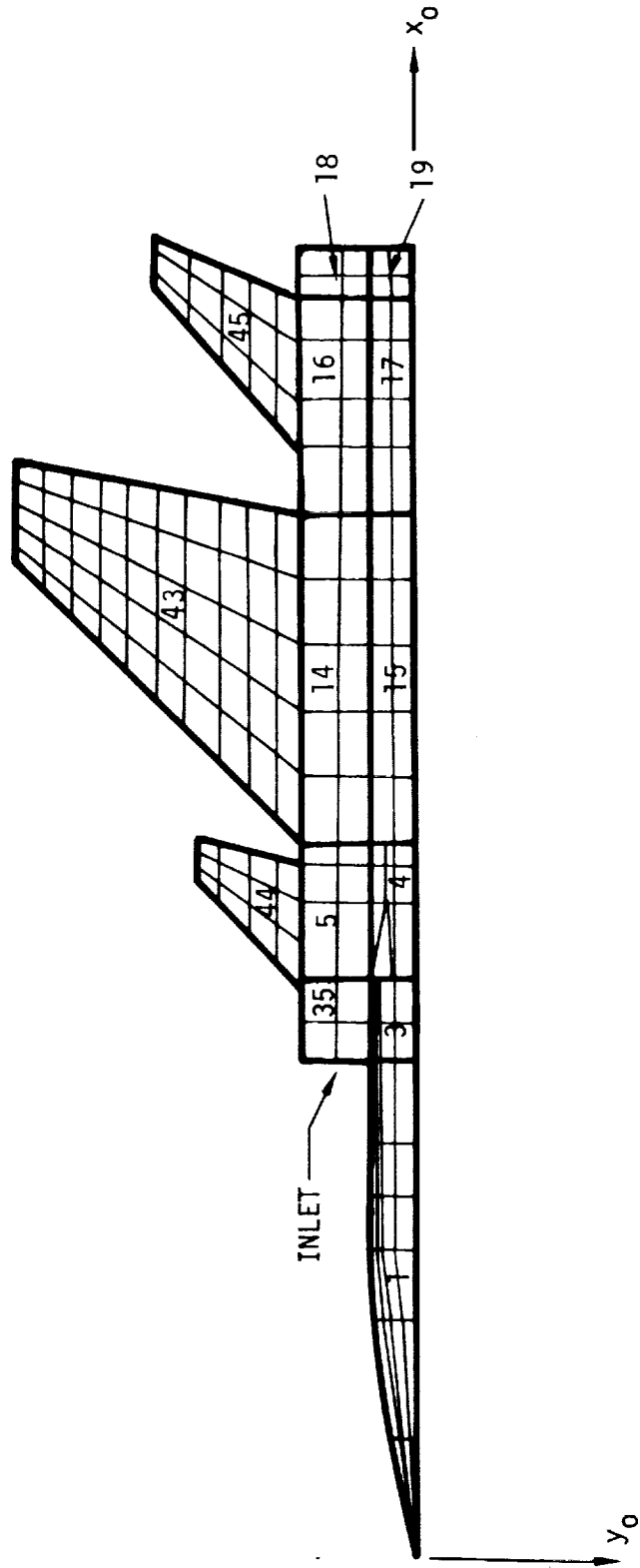

(b) Bottom View, image networks

Figure 3.2 - Continued

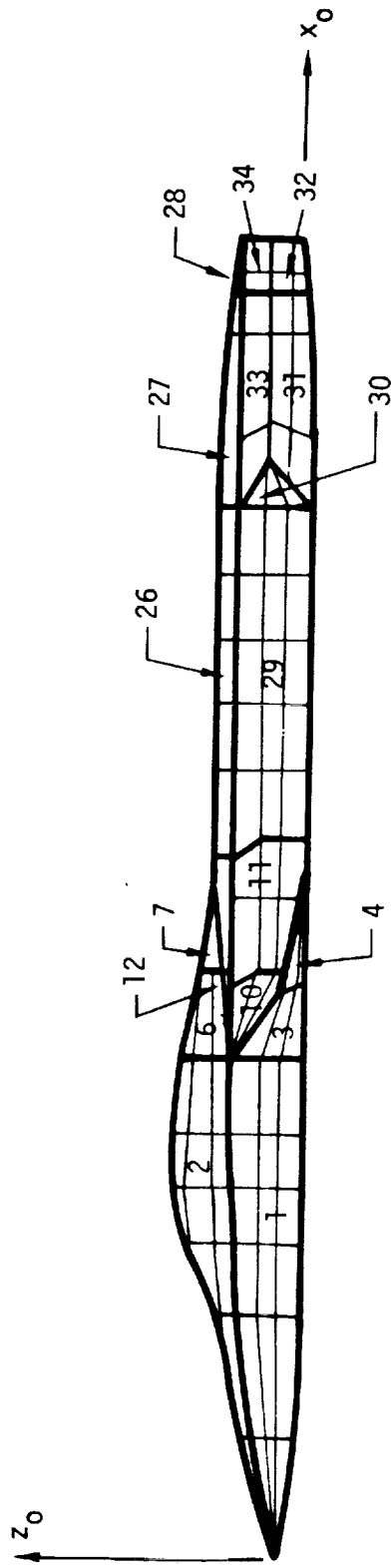

(c) Side View, image networks

Figure 3.2 - Concluded

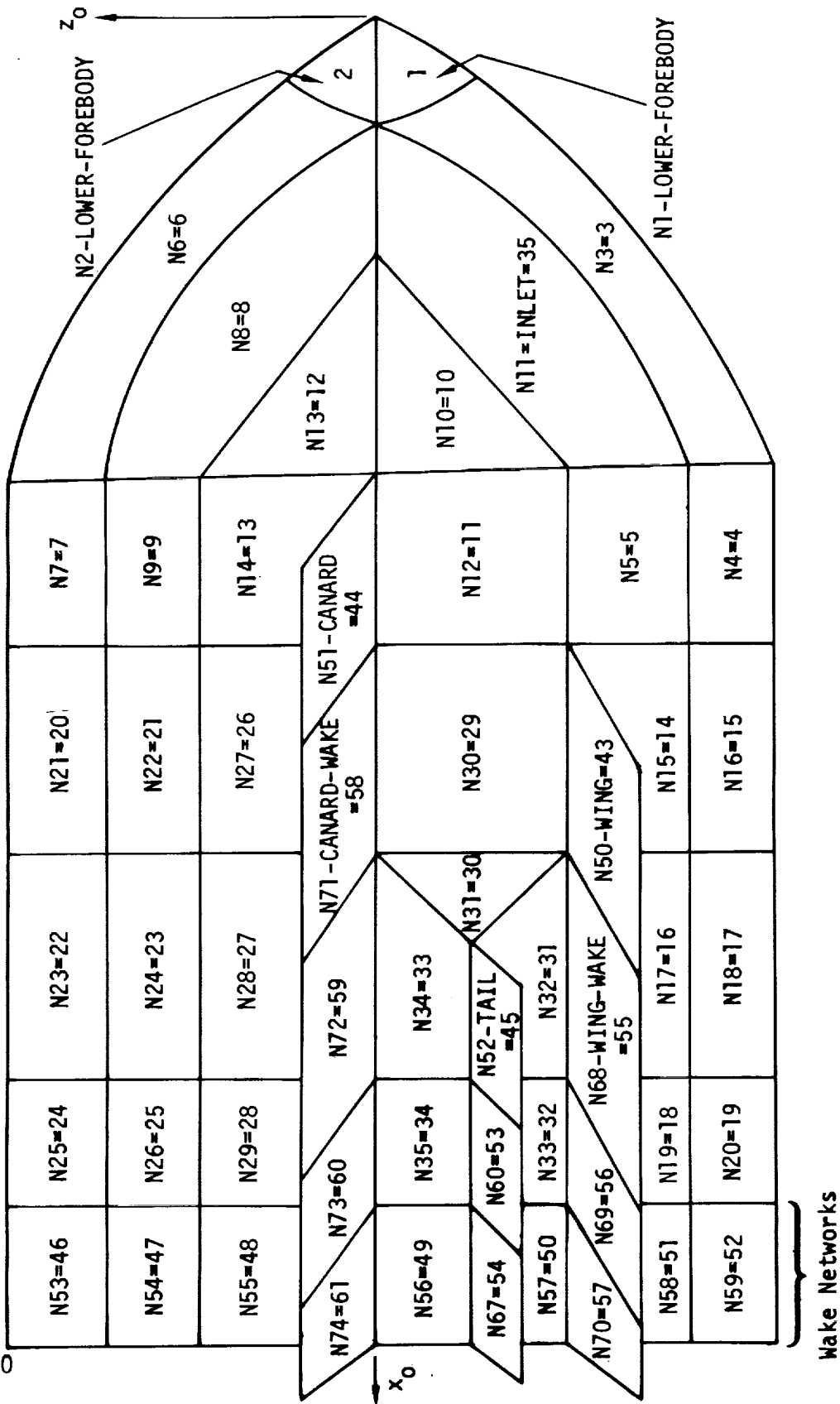

(a) "Side View"

Figure 3.3 - Schematic of weapons carriage airplane network abutments

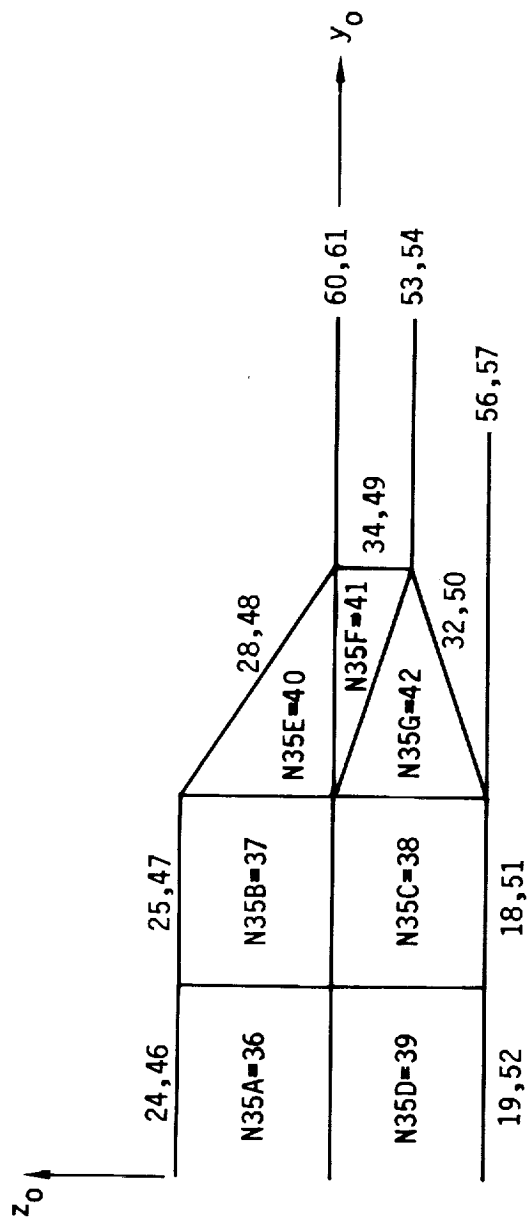

(b) "Rear View"

Figure 3.3 - Concluded

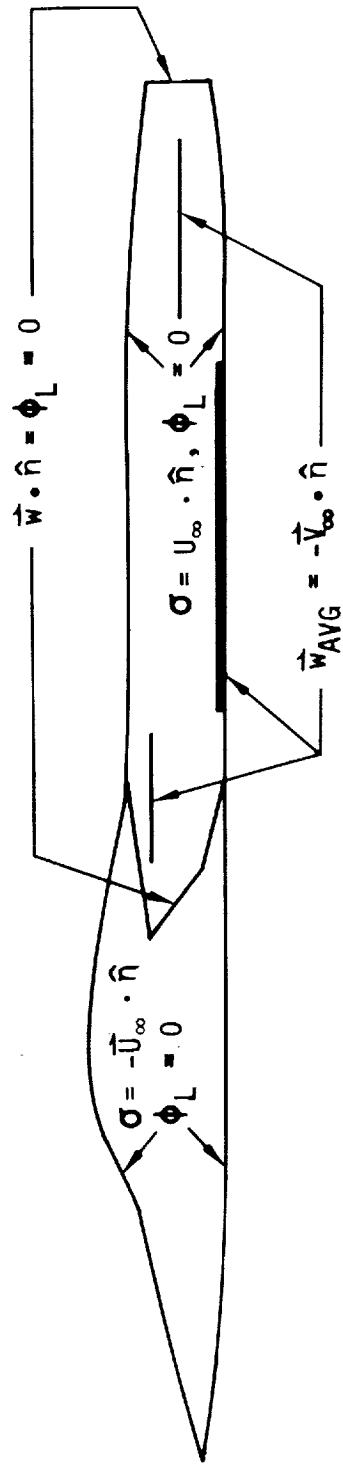

Figure 3.4 - Boundary conditions on weapons carriage airplane

```

// WEAPONS CARRIAGE AIRCRAFT
// EXAMPLE OF ANALYSIS OF COMPLEX CONFIGURATION
// ONE PLANE OF CONFIGURATION SYMMETRY
// SUPERSONIC FLOW, ONE PLANE OF FLOW SYMMETRY
// CONFIGURATION HAS SUPERINCLINED NETWORKS
BEGIN GLOBAL DATA /G1
PID WEAPONS CARRIAGE AIRPLANE WITHOUT WEAPON
UID USER IDENTIFICATION
// OMIT RECORD G4, DEFAULT IS ONE PLANE OF CONFIGURATION AND FLOW SYMMETRY
MACH = 2.0 CALPHA = 2.0 CBETA = 0.0
// SPECIFY 2 SOLUTIONS
ALPHA = 2., 0.
CHECKOUT PRINTS = DIP,1,2,3, DQG,1,2,4,5,6
PRESSURE COEFFICIENT RULES = SECOND-ORDER
// TURN OFF AUTOMATIC ABUTMENT SEARCH, SINCE ALL ABUTMENTS ARE SPECIFIED
// IN THE GEOMETRIC EDGE MATCHING DATA GROUP
TOLE=-.001
BEGIN NETWORK DATA
// THICK BODY NETWORKS FOLLOW
NETWORK = N1-LOWER-FOREBODY 7 6
  0.00000  0.00000  -.65400  3.00000  0.00000  -1.04700
  6.00000  0.00000  -1.05500  7.75000  0.00000  -1.06000
  9.10000  0.00000  -1.06200  10.45000  0.00000  -1.06600
  12.36900  0.00000  -1.06900
  0.00000  0.00000  -.65400  3.00000  .21500  -.97000
  6.00000  .35600  -1.04600  7.75000  .50900  -1.06000
  9.10000  .54800  -1.06200  10.45000  .50000  -1.06600
  12.36900  .45600  -1.06900
  0.00000  0.00000  -.65400  3.00000  .44000  -.89100
  6.00000  .69200  -.92700  7.75000  1.00000  -1.00000
  9.10000  1.09000  -1.03600  10.45000  1.00000  -1.06600
  12.36900  .91100  -1.06900
  0.00000  0.00000  -.65400  3.00000  .60000  -.65000
  6.00000  .97800  -.51300  7.75000  1.12000  -.50700
  9.10000  1.12000  -.52100  10.45000  1.09000  -.59100
  12.36900  1.10900  -.54700
  0.00000  0.00000  -.65400  3.00000  .68000  -.34500
  6.00000  1.04800  -.01400  7.75000  1.12000  0.00000
  9.10000  1.12000  0.00000  10.45000  1.12000  0.00000
  12.36900  1.12000  0.00000
  0.00000  0.00000  -.65400  3.00000  .60000  -.04000
  6.00000  .89700  .44300  7.75000  1.09000  .51000
  9.10000  1.12000  .63100  10.45000  1.12000  .58600
  12.36900  1.12000  .61500
BOUNDARY CONDITIONS = OVERALL 1 1

```

Figure 3.5 - Input for test case 3.

NETW = N2-LOWER-FOREBODY 7 4					
0.00000	0.00000	-.65400	3.00000	.60000	-.04000
6.00000	.89700	.44300	7.75000	1.09000	.51000
9.10000	1.12000	.63100	10.45000	1.12000	.58600
12.36900	1.12000	.61500			
0.00000	0.00000	-.65400	3.00000	.38000	.22000
6.00000	.55400	.78000	7.75000	.83000	.94000
9.10000	.88500	1.20000	10.45000	.88000	1.12000
12.36900	.96000	1.06500			
0.00000	0.00000	-.65400	3.00000	.20000	.31000
6.00000	.29800	.95500	7.75000	.59100	1.56000
9.10000	.61100	1.79000	10.45000	.60400	1.72000
12.36900	.59200	1.59200			
0.00000	0.00000	-.65400	3.00000	0.00000	.35700
6.00000	0.00000	1.04000	7.75000	0.00000	1.84000
9.10000	0.00000	2.02900	10.45000	0.00000	1.98300
12.36900	0.00000	1.83500			
NETWORK = N3 3 6					
12.36900	0.00000	-1.06900	13.43450	0.00000	-1.07200
14.50000	0.00000	-1.07500			
12.36900	.45600	-1.06900	13.43450	.48800	-1.07200
14.50000	.52000	-1.07500			
12.36900	.91100	-1.06900	13.43450	.86550	-1.02950
14.50000	.82000	-.98500			
12.36900	1.10900	-.54700	13.43450	1.11450	-.71850
14.50000	1.12000	-.89500			
12.36900	1.12000	0.00000	13.43450	1.12000	-.39500
14.50000	1.12000	-.79000			
12.36900	1.12000	.61500	13.43450	1.12000	-.06700
14.50000	1.12000	-.74800			
NETWORK = N4 5 4					
14.50000	0.00000	-1.07500	15.42500	0.00000	-1.07950
16.35000	0.00000	-1.08400	17.12500	0.00000	-1.09200
17.90000	0.00000	-1.10000			
14.50000	.52000	-1.07500	15.42500	.54000	-1.07850
16.35000	.56000	-1.08200	17.12500	.56000	-1.09100
17.90000	.56000	-1.10000			
14.50000	1.12000	-.89500	15.42500	.96000	-.98550
16.35000	.80000	-1.08100	17.12500	.80000	-1.09050
17.90000	.80000	-1.10000			
14.50000	1.12000	-.74800	15.42500	1.12000	-.91400
16.35000	1.12000	-1.08000	17.12500	1.12000	-1.09000
17.90000	1.12000	-1.10000			
NETWORK = N5 5 5					
14.50000	1.12000	-.74800	15.42500	1.12000	-.91400
16.35000	1.12000	-1.08000	17.12500	1.12000	-1.09000

Figure 3.5 - Continued.

17.90000	1.12000	-1.10000			
14.50000	1.50000	-.74800	15.42500	1.50000	-.91400
16.35000	1.50000	-1.08000	17.12500	1.50000	-1.09000
17.90000	1.50000	-1.10000			
14.50000	1.98500	-.74800	15.42500	1.98500	-.91400
16.35000	1.98500	-1.08000	17.12500	1.98500	-1.09000
17.90000	1.98500	-1.10000			
14.50000	2.40000	-.74800	15.42500	2.40000	-.91400
16.35000	2.40000	-1.08000	17.12500	2.40000	-1.09000
17.90000	2.40000	-1.10000			
14.50000	2.85000	-.74800	15.42500	2.85000	-.91400
16.35000	2.85000	-1.08000	17.12500	2.85000	-1.09000
17.90000	2.85000	-1.10000			
NETWORK = N6 2 4					
12.36900	1.12000	.61500	14.50000	1.12000	.89800
12.36900	.96000	1.06500	14.50000	.90000	1.11800
12.36900	.59200	1.59200	14.50000	.62000	1.39800
12.36900	0.00000	1.83500	14.50000	0.00000	1.58000
NETW = N7 3 3					
14.50000	1.12000	.89800	16.35000	1.12000	1.05900
17.35000	1.12000	1.09500			
14.50000	.62000	1.39800	16.35000	.57400	1.25700
17.35000	.56500	1.19000			
14.50000	0.00000	1.58000	16.35000	0.00000	1.34700
17.35000	0.00000	1.23800			
NETW = N8 3 3					
12.36900	2.85000	.61500	13.43450	2.85000	.75650
14.50000	2.85000	.89800			
12.36900	1.98500	.61500	13.43450	1.98500	.75650
14.50000	1.98500	.89800			
12.36900	1.12000	.61500	13.43450	1.12000	.75650
14.50000	1.12000	.89800			
NETW = N9 3 3					
14.50000	2.85000	.89800	16.35000	2.85000	1.05900
17.35000	2.85000	1.09500			
14.50000	1.98500	.89800	16.35000	1.98500	1.05900
17.35000	1.98500	1.09500			
14.50000	1.12000	.89800	16.35000	1.12000	1.05900
17.35000	1.12000	1.09500			
NETW = N10 3 4					
12.36900	2.85000	.61500	13.43450	2.85000	-.06700
14.50000	2.85000	-.74800			
12.36900	2.85000	.61500	13.43450	2.85000	.16000
14.50000	2.85000	-.37400			
12.36900	2.85000	.61500	13.43450	2.85000	.34000
14.50000	2.85000	0.00000			
12.36900	2.85000	.61500	13.43450	2.85000	.70000
14.35000	2.85000	.70000			

Figure 3.5 - Continued.

```

// NETWORK 11 IS SUPERINCLINED INLET- GROUPED
// WITH OTHER SUPERINCLINED NETWORKS FOR CONVENIENCE
NETWORK = N12 3 4
 14.50000  2.85000  -.74800  16.35000  2.85000  -1.08000
 17.90000  2.85000  -1.10000
 14.50000  2.85000  -.37400  16.35000  2.85000  -.52450
 17.90000  2.85000  -.55000
 14.50000  2.85000  0.00000  16.35000  2.85000  0.00000
 17.90000  2.85000  0.00000
 14.35000  2.85000  .70000  16.35000  2.85000  .70000
 17.35000  2.85000  .70000
NETW = N13 3 2
 12.36900  2.85000  .61500  13.43450  2.85000  .70000
 14.35000  2.85000  .70000
 12.36900  2.85000  .61500  13.43450  2.85000  .75650
 14.50000  2.85000  .89800
NETW = N14 3 2
 14.35000  2.85000  .70000  16.35000  2.85000  .70000
 17.35000  2.85000  .70000
 14.50000  2.85000  .89800  16.35000  2.85000  1.05900
 17.35000  2.85000  1.09500
NETW = N15 6 3
 17.90000  1.12000  -1.10000  19.54000  1.12000  -1.10000
 21.18000  1.12000  -1.10000  22.82000  1.12000  -1.10000
 24.46000  1.12000  -1.10000  26.13000  1.12000  -1.10000
 17.90000  1.98500  -1.10000  19.54000  1.98500  -1.10000
 21.18000  1.98500  -1.10000  22.82000  1.98500  -1.10000
 24.46000  1.98500  -1.10000  26.13000  1.92600  -1.10000
 17.90000  2.85000  -1.10000  19.54000  2.85000  -1.10000
 21.18000  2.85000  -1.10000  22.82000  2.85000  -1.10000
 24.46000  2.79000  -1.10000  26.13000  2.73000  -1.10000
NETW = N16 6 3
 17.90000  0.00000  -1.10000  19.54000  0.00000  -1.10000
 21.18000  0.00000  -1.10000  22.82000  0.00000  -1.10000
 24.46000  0.00000  -1.10000  26.13000  0.00000  -1.10000
 17.90000  .56000  -1.10000  19.54000  .56000  -1.10000
 21.18000  .56000  -1.10000  22.82000  .56000  -1.10000
 24.46000  .56000  -1.10000  26.13000  .56000  -1.10000
 17.90000  1.12000  -1.10000  19.54000  1.12000  -1.10000
 21.18000  1.12000  -1.10000  22.82000  1.12000  -1.10000
 24.46000  1.12000  -1.10000  26.13000  1.12000  -1.10000
NETW = N17 5 3
 26.13000  1.12000  -1.10000  27.80000  1.12000  -1.10000
 29.00000  1.12000  -1.10000  30.50000  1.12000  -1.10000
 31.60000  1.12000  -1.02000
 26.13000  1.92600  -1.10000  27.80000  1.87000  -1.10000
 29.00000  1.83000  -1.10000  30.50000  1.81000  -1.10000
 31.60000  1.81000  -1.02000

```

Figure 3.5 - Continued.

26.13000	2.73000	-1.10000	27.80000	2.62000	-1.10000
29.00000	2.50000	-1.10000	30.50000	2.50000	-1.10000
31.60000	2.50000	-1.02000			
NETW = N18	5 3				
26.13000	0.00000	-1.10000	27.80000	0.00000	-1.10000
29.00000	0.00000	-1.10000	30.50000	0.00000	-1.10000
31.60000	0.00000	-1.02000			
26.13000	.56000	-1.10000	27.80000	.56000	-1.10000
29.00000	.56000	-1.10000	30.50000	.56000	-1.10000
31.60000	.56000	-1.02000			
26.13000	1.12000	-1.10000	27.80000	1.12000	-1.10000
29.00000	1.12000	-1.10000	30.50000	1.12000	-1.10000
31.60000	1.12000	-1.02000			
NETW = N19	3 3				
31.60000	1.12000	-1.02000	32.00000	1.12000	-1.00000
32.85000	1.12000	-.90000			
31.60000	1.81000	-1.02000	32.00000	1.81000	-1.00000
32.85000	1.81000	-.90000			
31.60000	2.50000	-1.02000	32.00000	2.50000	-1.00000
32.85000	2.50000	-.90000			
NETW = N20	3 3				
31.60000	0.00000	-1.02000	32.00000	0.00000	-1.00000
32.85000	0.00000	-.90000			
31.60000	.56000	-1.02000	32.00000	.56000	-1.00000
32.85000	.56000	-.90000			
31.60000	1.12000	-1.02000	32.00000	1.12000	-1.00000
32.85000	1.12000	-.90000			
NETW = N21	4 3				
17.35000	1.12000	1.09500	19.54000	1.12000	1.10000
22.82000	1.12000	1.10000	26.13000	1.12000	1.10000
17.35000	.56500	1.19000	19.54000	.56000	1.10000
22.82000	.56000	1.10000	26.13000	.56000	1.10000
17.35000	0.00000	1.23800	19.54000	0.00000	1.10000
22.82000	0.00000	1.10000	26.13000	0.00000	1.10000
NETW = N22	4 3				
17.35000	2.85000	1.09500	19.54000	2.85000	1.10000
22.82000	2.85000	1.10000	26.13000	2.73000	1.10000
17.35000	1.98500	1.09500	19.54000	1.98500	1.10000
22.82000	1.98500	1.10000	26.13000	1.92000	1.10000
17.35000	1.12000	1.09500	19.54000	1.12000	1.10000
22.82000	1.12000	1.10000	26.13000	1.12000	1.10000
NETW = N23	5 3				
26.13000	1.12000	1.10000	27.80000	1.12000	1.10000
29.00000	1.12000	1.10000	30.50000	1.12000	1.10000
31.60000	1.12000	1.02000			
26.13000	.56000	1.10000	27.80000	.56000	1.10000
29.00000	.56000	1.10000	30.50000	.56000	1.10000
31.60000	.56000	1.02000			

Figure 3.5 - Continued.

26.13000	0.00000	1.10000	27.80000	0.00000	1.10000
29.00000	0.00000	1.10000	30.50000	0.00000	1.10000
31.60000	0.00000	1.02000			
NETW = N24	5 3				
26.13000	2.73000	1.10000	27.80000	2.62000	1.10000
29.00000	2.50000	1.10000	30.50000	2.50000	1.10000
31.60000	2.50000	1.02000			
26.13000	1.92000	1.10000	27.80000	1.87000	1.10000
29.00000	1.83000	1.10000	30.50000	1.81000	1.10000
31.60000	1.81000	1.02000			
26.13000	1.12000	1.10000	27.80000	1.12000	1.10000
29.00000	1.12000	1.10000	30.50000	1.12000	1.10000
31.60000	1.12000	1.02000			
NETW = N25	3 3				
31.60000	1.12000	1.02000	32.00000	1.12000	1.00000
32.85000	1.12000	.90000			
31.60000	.56000	1.02000	32.00000	.56000	1.00000
32.85000	.56000	.90000			
31.60000	0.00000	1.02000	32.00000	0.00000	1.00000
32.85000	0.00000	.90000			
NETW = N26	3 3				
31.60000	2.50000	1.02000	32.00000	2.50000	1.00000
32.85000	2.50000	.90000			
31.60000	1.81000	1.02000	32.00000	1.81000	1.00000
32.85000	1.81000	.90000			
31.60000	1.12000	1.02000	32.00000	1.12000	1.00000
32.85000	1.12000	.90000			
NETW = N27	4 2				
17.35000	2.85000	.70000	19.54000	2.85000	.70000
22.82000	2.85000	.70000	26.13000	2.82000	.70000
17.35000	2.85000	1.09500	19.54000	2.85000	1.10000
22.82000	2.85000	1.10000	26.13000	2.73000	1.10000
NETW = N28	5 2				
26.13000	2.82000	.70000	27.80000	2.88000	.70000
29.00000	2.83000	.70000	30.50000	2.81000	.70000
31.60000	2.80000	.70000			
26.13000	2.73000	1.10000	27.80000	2.62000	1.10000
29.00000	2.50000	1.10000	30.50000	2.50000	1.10000
31.60000	2.50000	1.02000			
NETW = N29	3 2				
31.60000	2.80000	.70000	32.00000	2.74000	.70000
32.85000	2.62000	.70000			
31.60000	2.50000	1.02000	32.00000	2.50000	1.00000
32.85000	2.50000	.90000			

Figure 3.5 - Continued.

```

NETW = N30 6 4
17.90000 2.85000 -1.10000 19.54000 2.85000 -1.10000
21.18000 2.85000 -1.10000 22.82000 2.85000 -1.10000
24.46000 2.79000 -1.10000 26.13000 2.73000 -1.10000
17.90000 2.85000 -.55000 19.54000 2.85000 -.55000
21.18000 2.85000 -.55000 22.82000 2.85000 -.55000
24.46000 2.79000 -.55000 26.13000 2.89000 -.55900
17.90000 2.85000 0.00000 19.54000 2.85000 0.00000
21.18000 2.85000 0.00000 22.82000 2.85000 0.00000
24.46000 2.79000 0.00000 26.13000 2.89000 0.00000
17.35000 2.85000 .70000 19.54000 2.85000 .70000
21.18000 2.85000 .70000 22.82000 2.85000 .70000
24.46042 2.8351321 .70000 26.13000 2.82000 .70000
NETW = N31 2 4
26.13000 2.73000 -1.10000 27.80000 3.03000 0.00000
26.13000 2.89000 -.55900 27.80000 3.03000 0.00000
26.13000 2.89000 0.00000 27.80000 3.03000 0.00000
26.13000 2.82000 .70000 27.80000 3.03000 0.00000
NETW = N32 5 3
26.13000 2.73000 -1.10000 27.80000 2.62000 -1.10000
29.00000 2.50000 -1.10000 30.50000 2.50000 -1.10000
31.60000 2.50000 -1.02000
26.96500 2.88000 -.55000 28.00000 2.95000 -.60300
29.00000 2.99000 -.63000 30.50000 2.98000 -.62000
31.60000 2.93000 -.56200
27.80000 3.03000 0.00000 28.20000 3.06000 0.00000
29.00000 3.12000 0.00000 30.50000 3.14000 0.00000
31.60000 3.09600 0.00000
NETW = N33 3 3
31.60000 2.50000 -1.02000 32.00000 2.50000 -1.00000
32.85000 2.50000 -.90000
31.60000 2.93000 -.56200 32.00000 2.89000 -.53500
32.85000 2.83000 -.44580
31.60000 3.09600 0.00000 32.00000 3.08000 0.00000
32.85000 2.97000 0.00000
NETW = N34 5 2
27.80000 3.03000 0.00000 28.20000 3.06000 0.00000
29.00000 3.12000 0.00000 30.50000 3.14000 0.00000
31.60000 3.09600 0.00000
26.13000 2.82000 .70000 27.80000 2.88000 .70000
29.00000 2.83000 .70000 30.50000 2.81000 .70000
31.60000 2.80000 .70000
NETW = N35 3 2
31.60000 3.09600 0.00000 32.00000 3.08000 0.00000
32.85000 2.97000 0.00000
31.60000 2.80000 .70000 32.00000 2.74000 .70000
32.85000 2.62000 .70000
// BEGIN SUPERINCLINED NETWORKS

```

Figure 3.5 - Continued.

```

NETW = N11-INLET 3 3
 12.36900  1.12000  .61500  13.43450  1.12000  -.06700
 14.50000  1.12000  -.74800
 12.36900  1.98500  .61500  13.43450  1.98500  -.06700
 14.50000  1.98500  -.74800
 12.36900  2.85000  .61500  13.43450  2.85000  -.06700
 14.50000  2.85000  -.74800
// SUPERINCLINED PANEL BOUNDARY CONDITIONS
BOUN = OVER,4,2,3,6,3
SING = SA DA
// BASE PLATE TO BODY STARTS NOW
NETW= N35A 2 3
 32.85000  0.00000  .90000  32.85000  0.00000  0.00000
 32.85000  .56000  .90000  32.85000  .56000  0.00000
 32.85000  1.12000  .90000  32.85000  1.12000  0.00000
SING = SA DA
NETW=N35B 2 3
 32.85000  1.12000  .90000  32.85000  1.12000  0.00000
 32.85000  1.81000  .90000  32.85000  1.81000  0.00000
 32.85000  2.50000  .90000  32.85000  2.50000  0.00000
SING = SA DA
NETW = N35C 2 3
 32.85000  1.12000  0.00000  32.85000  1.12000  -.90000
 32.85000  1.81000  0.00000  32.85000  1.81000  -.90000
 32.85000  2.50000  0.00000  32.85000  2.50000  -.90000
SING = SA DA
NETW = N35D 2 3
 32.85000  0.00000  0.00000  32.85000  0.00000  -.90000
 32.85000  .56000  0.00000  32.85000  .56000  -.90000
 32.85000  1.12000  0.00000  32.85000  1.12000  -.90000
// NORMALS ON NEXT 3 NETWORKS ARE REVERSED
SING = SA DA
NETW=N35E 3 2
 32.85000  2.50000  .90000  32.85000  2.56000  .80000
 32.85000  2.62000  .70000
 32.85000  2.50000  0.00000  32.85000  2.50000  0.00000
 32.85000  2.50000  0.00000
BOUN =OVER,4,1,3,5,3
SING = SA DA
NETW = N35F 3 2
 32.85000  2.62000  .70000  32.85000  2.79500  .35000
 32.85000  2.97000  0.00000
 32.85000  2.50000  0.00000  32.85000  2.50000  0.00000
 32.85000  2.50000  0.00000
SING = SA DA

```

Figure 3.5 - Continued.

```

NETW=N35G 3 2
 32.85000  2.97000  0.00000  32.85000  2.83000  -.44580
 32.85000  2.50000  -.90000
 32.85000  2.50000  0.00000  32.85000  2.50000  0.00000
 32.85000  2.50000  0.00000
SING = SA DA
// BEGIN THIN WING NETWORKS
NETW = N50-WING 11 6
 17.90000  2.85000 -1.10000  18.59000  3.55000 -1.10000
 19.28000  4.25000 -1.10000  19.92100  4.90000 -1.10000
 20.66000  5.65000 -1.10000  21.35000  6.35000 -1.10000
 22.04000  7.05000 -1.10000  22.73000  7.75000 -1.10000
 23.42000  8.45000 -1.10000  24.11000  9.15000 -1.10000
 24.80000  9.85000 -1.10000
 19.54000  2.85000 -1.10000  20.12000  3.55000 -1.10000
 20.70000  4.25000 -1.10000  21.24000  4.90000 -1.10000
 21.86000  5.65000 -1.10000  22.44000  6.35000 -1.10000
 23.02000  7.05000 -1.10000  23.60000  7.75000 -1.10000
 24.18000  8.45000 -1.10000  24.76000  9.15000 -1.10000
 25.34000  9.85000 -1.10000
 21.18000  2.85000 -1.10000  21.65000  3.55000 -1.10000
 22.12000  4.25000 -1.10000  22.56000  4.90000 -1.10000
 23.06000  5.65000 -1.10000  23.53000  6.35000 -1.10000
 24.00000  7.05000 -1.10000  24.47000  7.75000 -1.10000
 24.94000  8.45000 -1.10000  25.41000  9.15000 -1.10000
 25.88000  9.85000 -1.10000
 22.82000  2.85000 -1.10000  23.18000  3.55000 -1.10000
 23.54000  4.25000 -1.10000  23.87000  4.90000 -1.10000
 24.26000  5.65000 -1.10000  24.62000  6.35000 -1.10000
 24.98000  7.05000 -1.10000  25.34000  7.75000 -1.10000
 25.70000  8.45000 -1.10000  26.06000  9.15000 -1.10000
 26.42000  9.85000 -1.10000
 24.46000  2.79000 -1.10000  24.71000  3.55000 -1.10000
 24.96000  4.25000 -1.10000  25.19000  4.90000 -1.10000
 25.46000  5.65000 -1.10000  25.71000  6.35000 -1.10000
 25.96000  7.05000 -1.10000  26.21000  7.75000 -1.10000
 26.46000  8.45000 -1.10000  26.71000  9.15000 -1.10000
 26.96000  9.85000 -1.10000
 26.13000  2.73000 -1.10000  26.24000  3.55000 -1.10000
 26.38000  4.25000 -1.10000  26.51000  4.90000 -1.10000
 26.66000  5.65000 -1.10000  26.80000  6.35000 -1.10000
 26.94000  7.05000 -1.10000  27.08000  7.75000 -1.10000
 27.22000  8.45000 -1.10000  27.36000  9.15000 -1.10000
 27.50000  9.85000 -1.10000
BOUN = OVER,1,3

```

Figure 3.5 - Continued.

```

NETW = N51-CANARD 3 4
 14.35000  2.85000  .70000 15.62000  4.10000  .70000
 16.90000  5.37000  .70000
 15.35000  2.85000  .70000 16.33000  4.10000  .70000
 17.35000  5.37000  .70000
 16.35000  2.85000  .70000 17.00000  4.10000  .70000
 17.67000  5.37000  .70000
 17.35000  2.85000  .70000 17.72000  4.10000  .70000
 18.08000  5.37000  .70000
NETW = N52-TAIL 5 4
 27.80000  3.03000  0.00000 28.83260  3.90000  0.00000
 29.84150  4.75000  0.00000 30.73180  5.50000  0.00000
 31.80000  6.40000  0.00000
 29.00000  3.12000  0.00000 29.88480  3.90000  0.00000
 30.69430  4.75000  0.00000 31.40920  5.50000  0.00000
 32.26700  6.40000  0.00000
 30.50000  3.14000  0.00000 30.93710  3.90000  0.00000
 31.54720  4.75000  0.00000 32.08660  5.50000  0.00000
 32.73300  6.40000  0.00000
 31.60000  3.09600  0.00000 31.98930  3.90000  0.00000
 32.40000  4.75000  0.00000 32.76400  5.50000  0.00000
 33.20000  6.40000  0.00000
// WAKE NETWORKS BEGIN
NETW = N53 2 3
 32.85000  0.00000  .90000 999.99999  0.00000  .90000
 32.85000  .56000  .90000 999.99999  .56000  .90000
 32.85000  1.12000  .90000 999.99999  1.12000  .90000
BOUN = OVER,1,4
NETW = N54 2 3
 32.85000  1.12000  .90000 999.99999  1.12000  .90000
 32.85000  1.81000  .90000 999.99999  1.81000  .90000
 32.85000  2.50000  .90000 999.99999  2.50000  .90000
NETW = N55 2 2
 32.85000  2.50000  .90000 999.99999  2.50000  .90000
 32.85000  2.62000  .70000 999.99999  2.62000  .70000
NETW = N56 2 2
 32.85000  2.62000  .70000 999.99999  2.62000  .70000
 32.85000  2.97000  0.00000 999.99999  2.97000  0.00000
NETW = N57 2 3
 32.85000  2.97000  0.00000 999.99999  2.97000  0.00000
 32.85000  2.83000  -.44580 999.99999  2.83000  -.44580
 32.85000  2.50000  -.90000 999.99999  2.50000  -.90000
NETW = N58 2 3
 32.85000  2.50000  -.90000 999.99999  2.50000  -.90000
 32.85000  1.81000  -.90000 999.99999  1.81000  -.90000
 32.85000  1.12000  -.90000 999.99999  1.12000  -.90000

```

Figure 3.5 - Continued.

NETW = N59 2 3					
32.85000	1.12000	-.90000	999.99999	1.12000	-.90000
32.85000	.56000	-.90000	999.99999	.56000	-.90000
32.85000	0.00000	-.90000	999.99999	0.00000	-.90000
NETW = N60 3 5					
31.6	3.096	.0	32.	3.08	.0
32.85	2.97	0.			
31.9893	3.9	0.	32.35	3.9	0.
33.30000	3.90000	0.00000			
32.40000	4.75000	0.00000	32.77000	4.75000	0.00000
33.67000	4.75000	0.00000			
32.76400	5.50000	0.00000	33.10000	5.50000	0.00000
34.00000	5.50000	0.00000			
33.20000	6.40000	0.00000	33.80000	6.40000	0.00000
34.45000	6.40000	0.00000			
NETW = N67 2 5					
32.85000	2.97000	0.00000	999.99999	2.97000	0.00000
33.30000	3.90000	0.00000	999.99999	3.90000	0.00000
33.67000	4.75000	0.00000	999.99999	4.75000	0.00000
34.00000	5.50000	0.00000	999.99999	5.50000	0.00000
34.45000	6.40000	0.00000	999.99999	6.40000	0.00000
NETW = N68-WING-WAKE 5 11					
26.13000	2.73000	-1.10000	27.80000	2.62000	-1.10000
29.00000	2.50000	-1.10000	30.50000	2.50000	-1.10000
31.60000	2.50000	-1.02000			
26.24000	3.55000	-1.10000	27.80000	3.55000	-1.10000
29.00000	3.55000	-1.10000	30.50000	3.55000	-1.10000
31.60000	3.55000	-1.02000			
26.38000	4.25000	-1.10000	27.80000	4.25000	-1.10000
29.00000	4.25000	-1.10000	30.50000	4.25000	-1.10000
31.60000	4.25000	-1.02000			
26.51000	4.90000	-1.10000	27.80000	4.90000	-1.10000
29.00000	4.90000	-1.10000	30.50000	4.90000	-1.10000
31.60000	4.90000	-1.02000			
26.66000	5.65000	-1.10000	27.80000	5.65000	-1.10000
29.00000	5.65000	-1.10000	30.50000	5.65000	-1.10000
31.60000	5.65000	-1.02000			
26.80000	6.35000	-1.10000	27.80000	6.35000	-1.10000
29.00000	6.35000	-1.10000	30.50000	6.35000	-1.10000
31.60000	6.35000	-1.02000			
26.94000	7.05000	-1.10000	27.80000	7.05000	-1.10000
29.00000	7.05000	-1.10000	30.50000	7.05000	-1.10000
31.60000	7.05000	-1.02000			
27.08000	7.75000	-1.10000	27.80000	7.75000	-1.10000
29.00000	7.75000	-1.10000	30.50000	7.75000	-1.10000
31.60000	7.75000	-1.02000			

Figure 3.5 - Continued.

27.22000	8.45000	-1.10000	27.80000	8.45000	-1.10000
29.00000	8.45000	-1.10000	30.50000	8.45000	-1.10000
31.60000	8.45000	-1.02000			
27.36000	9.15000	-1.10000	27.80000	9.15000	-1.10000
29.00000	9.15000	-1.10000	30.50000	9.15000	-1.10000
31.60000	9.15000	-1.02000			
27.50000	9.85000	-1.10000	27.80000	9.85000	-1.10000
29.00000	9.85000	-1.10000	30.50000	9.85000	-1.10000
31.60000	9.85000	-1.02000			
NETW = N69	3	11			
31.60000	2.50000	-1.02000	32.00000	2.50000	-1.00000
32.85000	2.50000	-.90000			
31.60000	3.55000	-1.02000	32.00000	3.55000	-1.00000
32.85000	3.55000	-.90000			
31.60000	4.25000	-1.02000	32.00000	4.25000	-1.00000
32.85000	4.25000	-.90000			
31.60000	4.90000	-1.02000	32.00000	4.90000	-1.00000
32.85000	4.90000	-.90000			
31.60000	5.65000	-1.02000	32.00000	5.65000	-1.00000
32.85000	5.65000	-.90000			
31.60000	6.35000	-1.02000	32.00000	6.35000	-1.00000
32.85000	6.35000	-.90000			
31.60000	7.05000	-1.02000	32.00000	7.05000	-1.00000
32.85000	7.05000	-.90000			
31.60000	7.75000	-1.02000	32.00000	7.75000	-1.00000
32.85000	7.75000	-.90000			
31.60000	8.45000	-1.02000	32.00000	8.45000	-1.00000
32.85000	8.45000	-.90000			
31.60000	9.15000	-1.02000	32.00000	9.15000	-1.00000
32.85000	9.15000	-.90000			
31.60000	9.85000	-1.02000	32.00000	9.85000	-1.00000
32.85000	9.85000	-.90000			
NETW = N70	2	11			
32.85000	2.50000	-.90000	999.99999	2.50000	-.90000
32.85000	3.55000	-.90000	999.99999	3.55000	-.90000
32.85000	4.25000	-.90000	999.99999	4.25000	-.90000
32.85000	4.90000	-.90000	999.99999	4.90000	-.90000
32.85000	5.65000	-.90000	999.99999	5.65000	-.90000
32.85000	6.35000	-.90000	999.99999	6.35000	-.90000
32.85000	7.05000	-.90000	999.99999	7.05000	-.90000
32.85000	7.75000	-.90000	999.99999	7.75000	-.90000
32.85000	8.45000	-.90000	999.99999	8.45000	-.90000
32.85000	9.15000	-.90000	999.99999	9.15000	-.90000
32.85000	9.85000	-.90000	999.99999	9.85000	-.90000

Figure 3.5 - Continued.

```

NETW = N71-CANARD-WAKE 4 3
17.35000 2.85000 .70000 19.54000 2.85000 .70000
22.82000 2.85000 .70000 26.13000 2.82000 .70000
17.72000 4.10000 .70000 19.54000 4.10000 .70000
22.82000 4.10000 .70000 26.13000 4.10000 .70000
18.08000 5.37000 .70000 19.54000 5.37000 .70000
22.82000 5.37000 .70000 26.13000 5.37000 .70000
NETWORK=N72 5 3
26.13000 2.82000 .70000 27.80000 2.88000 .70000
29.00000 2.83000 .70000 30.50000 2.81000 .70000
31.60000 2.80000 .70000
26.13000 4.10000 .70000 27.80000 4.10000 .70000
29.00000 4.10000 .70000 30.50000 4.10000 .70000
31.60000 4.10000 .70000
26.13000 5.37000 .70000 27.80000 5.37000 .70000
29.00000 5.37000 .70000 30.50000 5.37000 .70000
31.60000 5.37000 .70000
NETW = N73 3 3
31.60000 2.80000 .70000 32.00000 2.74000 .70000
32.85000 2.62000 .70000
31.60000 4.10000 .70000 32.00000 4.10000 .70000
32.85000 4.10000 .70000
31.60000 5.37000 .70000 32.00000 5.37000 .70000
32.85000 5.37000 .70000
NETW = N74 2 3
32.85000 2.62000 .70000 999.99999 2.62000 .70000
32.85000 4.10000 .70000 999.99999 4.10000 .70000
32.85000 5.37000 .70000 999.99999 5.37000 .70000
BEGIN GEOM
ABUT=1,2,ENTI=2,4
ABUT=1,3,ENTI=3,1
ABUT=1,4,ENTI
PLAN=FIRST
ABUT=2,2,ENTI
PLAN=FIRST
ABUT=2,3,ENTI=6,1
ABUT=3,2,ENTI=35,4
ABUT=3,3,ENTI=4,1
ABUT=3,4,ENTI
PLAN=FIRST
ABUT=4,2,ENTI=5,4
ABUT=4,3,ENTI=15,1
ABUT=4,4,ENTI
PLAN=FIRST

```

Figure 3.5 - Continued.

ABUT=5,1,ENTI=35,3
ABUT=5,2,ENTI=11,4
ABUT=5,3,ENTI=14,1
ABUT=6,2,ENTI
PLAN=FIRST
ABUT=6,3,ENTI=7,1
ABUT=6,4,ENTI=8,2
ABUT=7,2,ENTI
PLAN=FIRST
ABUT=7,3,ENTI=20,1
ABUT=7,4,ENTI=9,2
ABUT=8,1,ENTI=35,1
ABUT=8,3,ENTI=9,1
ABUT=8,4,ENTI=12,2
ABUT=9,3,ENTI=21,1
ABUT=9,4,ENTI=13,2
ABUT=10,2,ENTI=12,4
ABUT=10,3,ENTI=11,1
ABUT=10,4,ENTI=35,2
ABUT=11,2,ENTI=13,4=44,1
ABUT=11,3,ENTI=29,1
ABUT=12,3,ENTI=13,1
ABUT=13,3,ENTI=26,1
ABUT=14,2,ENTI=29,4=43,1
ABUT=14,3,ENTI=16,1
ABUT=14,4,ENTI=15,2
ABUT=15,3,ENTI=17,1
ABUT=15,4,ENTI
PLAN=FIRST
ABUT=16,2,ENTI=31,4=55,4
ABUT=16,3,ENTI=18,1
ABUT=16,4,ENTI=17,2
ABUT=17,3,ENTI=19,1
ABUT=17,4,ENTI
PLAN=FIRST
ABUT=18,2,ENTI=32,4=56,4
ABUT=18,3,ENTI=38,3=51,1
ABUT=18,4,ENTI=19,2
ABUT=19,3,ENTI=39,3=52,1
ABUT=19,4,ENTI
PLAN=FIRST
ABUT=20,2,ENTI
PLAN=FIRST
ABUT=20,3,ENTI=22,1
ABUT=20,4,ENTI=21,2
ABUT=21,3,ENTI=23,1
ABUT=21,4,ENTI=26,2
ABUT=22,2,ENTI
PLAN=FIRST

Figure 3.5 - Continued.

ABUT=22,3,ENTI=24,1
ABUT=22,4,ENTI=23,2
ABUT=23,3,ENTI=25,1
ABUT=23,4,ENTI=27,2
ABUT=24,2,ENTI
PLAN=FIRST
ABUT=24,3,ENTI=36,1=46,1
ABUT=24,4,ENTI=25,2
ABUT=25,3,ENTI=37,1=47,1
ABUT=25,4,ENTI=28,2
ABUT=26,3,ENTI=27,1
ABUT=26,4,ENTI=29,2=58,4
ABUT=27,3,ENTI=28,1
ABUT=27,4,ENTI=33,2=59,4
ABUT=28,3,ENTI=40,4=48,1
ABUT=28,4,ENTI=34,2=60,4
ABUT=29,3,ENTI=30,1
ABUT=30,2,ENTI=33,1
ABUT=30,4,ENTI=31,1
ABUT=31,2,ENTI=33,4=45,1
ABUT=31,3,ENTI=32,1
ABUT=32,2,ENTI=34,4=53,4
ABUT=32,3,ENTI=42,4=50,1
ABUT=33,3,ENTI=34,1
ABUT=34,3,ENTI=41,4=49,1
ABUT=36,2,ENTI=37,4
ABUT=36,3,ENTI=39,1
ABUT=36,4,ENTI
PLAN=FIRST
ABUT=37,2,ENTI=40,1
ABUT=37,3,ENTI=38,1
ABUT=38,2,ENTI=42,3
ABUT=38,4,ENTI=39,2
ABUT=39,4,ENTI
PLAN=FIRST
ABUT=40,3,ENTI=41,1
ABUT=41,3,ENTI=42,1
ABUT=43,2,ENTI=55,1
ABUT=44,2,ENTI=58,1
ABUT=45,2,ENTI=53,1
ABUT=46,2,ENTI=47,4
ABUT=46,4,ENTI
PLAN=FIRST
ABUT=47,2,ENTI=48,4
ABUT=48,2,ENTI=49,4=61,4
ABUT=49,2,ENTI=50,4=54,4
ABUT=50,2,ENTI=51,4=57,4

Figure 3.5 - Continued.

```
ABUT=51,2,ENTI=52,4
ABUT=52,2,ENTI
PLAN=FIRST
ABUT=53,3,ENTI=54,1
ABUT=55,3,ENTI=56,1
ABUT=56,3,ENTI=57,1
ABUT=58,3,ENTI=59,1
ABUT=59,3,ENTI=60,1
ABUT=60,3,ENTI=61,1
BEGIN FLOW PROPERTIES DATA
SURFACE FLOW PROPERTIES =ALPHA.2
SOLUTIONS = 1
POINTS = CENTER
SURFACE SELECTION = UPPER,UPLO
PRINTOUT = ALL
DATA BASE = ALL
FORCES AND MOMENTS
SOLUTIONS = 1, 2
CASE = ALL-NETWORKS
SURFACE SELECTION = LOUP
BEGIN PRINT PLOT DATA
GEOMETRY DATA
POINT DATA
CONFIGURATION DATA
END PROBLEM DEFINITION
```

Figure 3.5 - Concluded.

	$\alpha = 0^\circ$		$\alpha = 2^\circ$	
	PAN AIR	PILOT CODE	PAN AIR	PILOT CODE
configuration				
FX	1.282	1.297	1.206	1.228
FY	.703	.694	15.233	15.435
FZ	-29.864	-28.961	-352.689	-356.475
wing FZ	.629	.616	3.864	3.879
canard FZ	-.119	-.129	.425	.446
tail FZ	-.080	-.071	.446	.474
base FX	.011		.014	.009

Note: coefficients are for reference axis system, second-order pressure formula, and unit reference parameters.

Figure 3.6 – Comparison of PAN AIR and Pilot Code forces and moments.

4. THIN DELTA WING

Purpose

The purpose of this case is to validate several basic PAN AIR capabilities for a flow which exhibits large pressure gradients and, therefore, is a flow for which errors in panel influence coefficients are likely to be evident.

Configuration, Flow, and Modeling

Two separate cases are discussed. In both cases, the wing is thin, planar, and at $.573^\circ$ angle of attack. In the first case, the geometry and flow are symmetric and the wing sweep angle is 60° . In the second case, there is a large angle of sideslip modeled by paneling the wing with an asymmetric geometry having sweep angles of 35° and 65° for the left and right leading edges, respectively. The paneling of the wings is illustrated in figures 4.1 and 4.2. In both cases, the Mach number is 1.414.

Conical flow theory (e.g., Jones and Cohen, reference 4.1, Cases 6 and 8 of Table A,13a) can be used to predict the pressure on these wing surfaces. In either case the pressure is constant on any line emanating from the apex of the wing. In the symmetric case, the leading edges are subsonic, and, thus, the pressure distribution on any line with constant x_0 or y_0 coordinate is a smooth function that approaches infinity at the leading edge of the wing. In the yawed case, the left leading edge of the wing is supersonic and the right leading edge is subsonic. As a result, the pressure on a line of constant x_0 is constant from the supersonic edge to the intersection with the left Mach line from the apex. At the intersection a discontinuity in the slope of the pressure occurs. Furthermore, the pressure approaches infinity as the subsonic leading edge is approached.

The boundary conditions imposed are the standard of zero normal flow on a thin surface (class 1, subclass 3). A wake is attached to the trailing edge of each wing to prevent the program from forcing the doublet strength to zero there.

Input

Symmetric Delta Wing. The input for this case is shown in figure 4.3. The input geometry corresponds to the M and N directions shown in figure 4.1. As a result of the ordering of the input points, the wing network normal is in the $-z_0$ direction. The compressibility direction (defined by CALPHA) equals the direction of the uniform onset flow (defined by ALPHA).

Record N3 following the wing geometry tells PAN AIR to save the velocity influence matrices so that they will be available for using the VIC-LAMBDA method of computing surface velocities, pressures, forces, and moment. Records SF6 and FM13 tell PAN AIR to actually use the VIC-LAMBDA method. The VIC-LAMBDA method generally gives more accurate results compared to the BOUNDARY-CONDITION method.

An edge force calculation is requested (record FM9), but, since the panelling in the direction nominally perpendicular to the leading edge is not uniform, cosine, or semicosine (See Appendix O of the theory manual for version 1.1 or later), the edge forces will not be accurate.

Yawed Delta Wing. The input data is listed in figure 4.4. The M and N directions are shown in figure 4.2. Thus the network normal vector is in the $+z_0$ direction. The angle of attack for the compressibility direction is set by default to zero.

An edge force calculation is requested (record FM9), but, since the panelling in the direction nominally perpendicular to the leading edge is not uniform, cosine, or semicosine (See Appendix O of the theory manual for version 1.1 or later), the edge forces will not be accurate.

Results and Discussion

Symmetric Delta Wing. Figure 4.5 compares second order pressure coefficients predicted by both the PAN AIR pilot code and by PAN AIR for two columns of panel center control points (a column of points runs in the M direction). The first column is essentially oriented in the x_0 direction, so location is defined by percent chord, while the second column is essentially in the y_0 direction, so location is defined by the parameter y_0/s , where s is the semispan.

The delta wing in supersonic flow puts PAN AIR to a fairly stringent test. The theoretical pressures are infinite on the subsonic leading edge of the wing and are constant on the x_0 axis. Therefore the pressure changes very rapidly near the intersection of these two lines (i.e., near the apex of the wing). Thus in the case of the symmetric delta wing the pressure along the first column of panel center control points should be a function that has rapidly varying value and slope, that starts off infinitely large, and that almost immediately settles down to an approximately constant value. Figure 4.5 shows both PAN AIR and its pilot code generally predicting this type of behavior. However, it is apparent from ref. 4.1 that the pressure distribution along column 1 ought to be a monotonic function of percent chord. This feature is not displayed in figure 4.5(a), and, consequently, there is some inaccuracy. This inaccuracy is most likely occurring on at least the first four panels from the apex.

Yawed Delta Wing. Figure 4.6 compares pilot code results, PAN AIR results, and theoretical results from Jones and Cohen, for the yawed wing. Pressure is plotted as a function of span location y_0/s , where $y_0/s = -1$ corresponds to the supersonic leading edge, and $y_0/s = 0$ corresponds to the x_0 axis. The PAN AIR values of pressure coefficient are essentially indistinguishable from the pilot code values, and the results from both codes agree well with the theoretical results.

REFERENCES

- 4.1 Jones, Robert T.; and Cohen, Doris: High Speed Wing Theory. Volume 6 of Princeton Aeronautical Paperbacks. Princeton University Press, 1960.

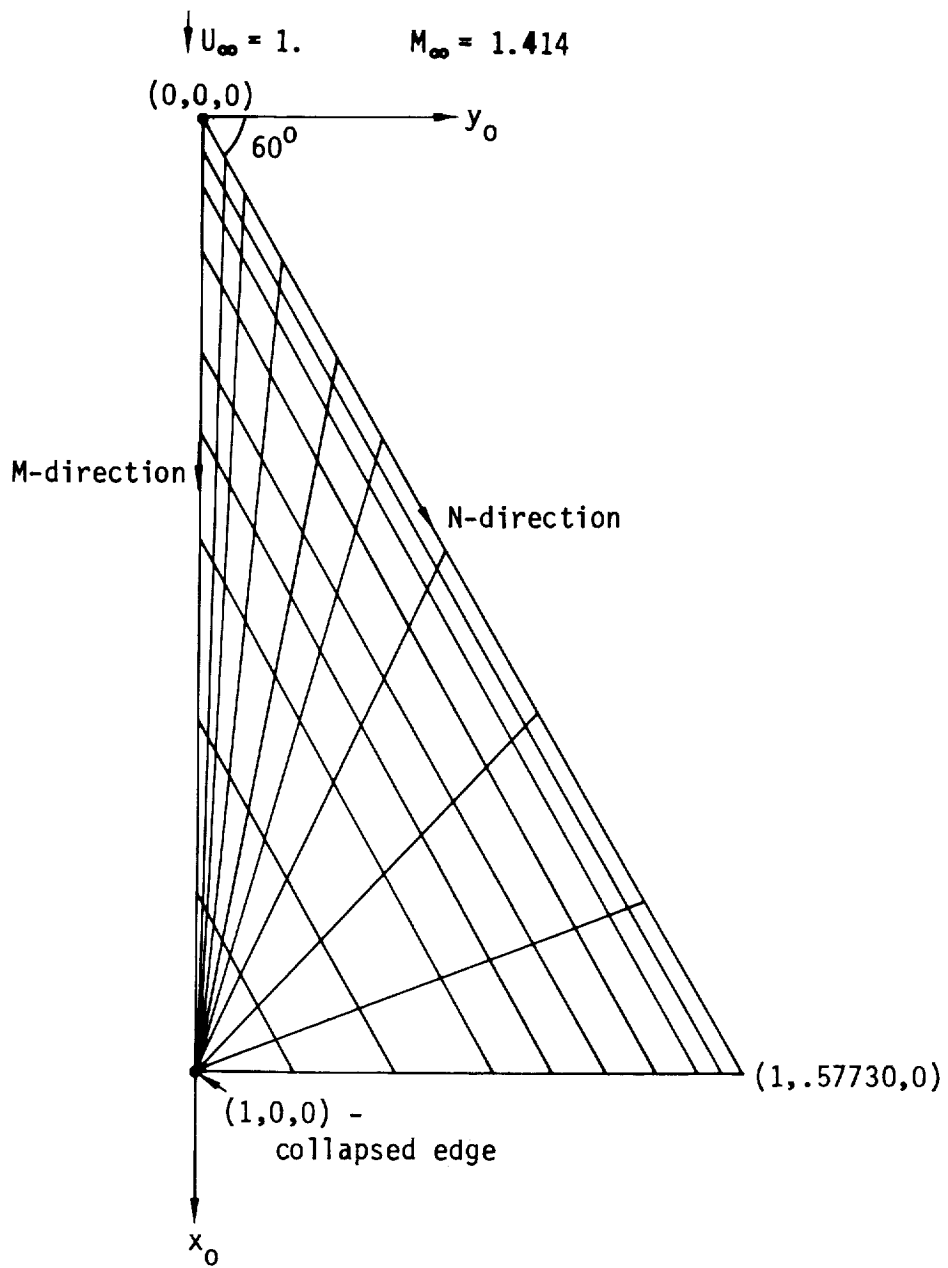

Figure 4.1 - Paneling of symmetric delta wing

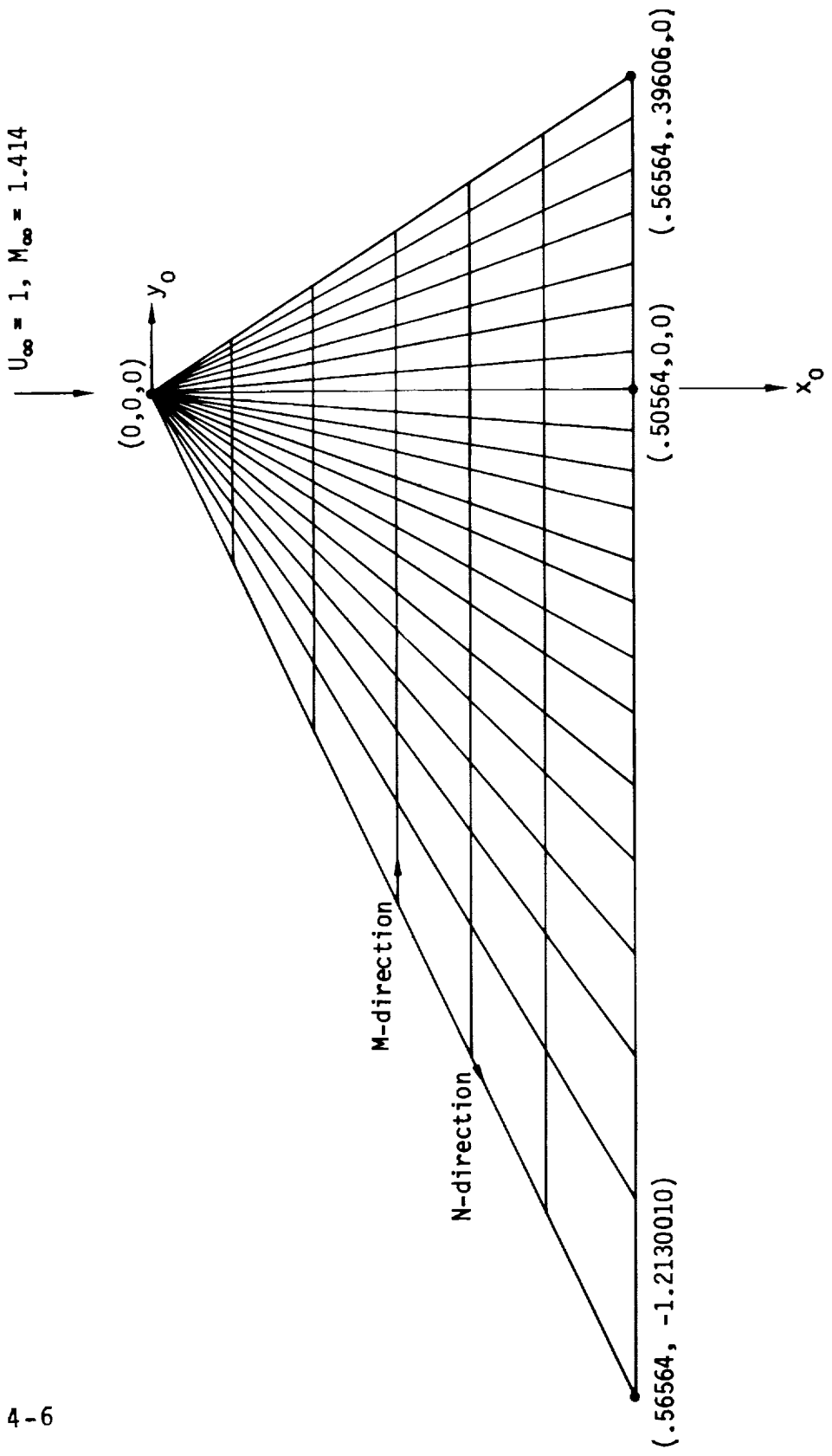

Figure 4.2 - Paneling on yawed delta wing

```

// PAN AIR CASE MANUAL CASE 4 (FIRST MODEL)
BEGIN GLOBAL DATA /G1
// DEFINE PROBLEM ID.
PID = SYMMETRIC THIN DELTA WING
// DEFINE USER ID.
UID = PANAIR-USER IDENTIFICATION
// CONFIGURATION AND FLOW ARE SYMMETRIC ABOUT THE Y=0 PLANE.
CONFIGURATION = FIRST, 0., 1., 0., 0., 0., 0., SYMMETRIC-FLOW /G4-DEFAULT
// DEFINE MACH NUMBER AND COMPRESSIBILITY DIRECTION
MACH = 1.414 $CALPHA = .573 $CBETA = 0. /G5
// DEFINE ONSET FLOW FOR ONE SOLUTION
// FOR THIS SOLUTION, ONSET FLOW IS UNIFORM, HAS UNIT MAGNITUDE AND IS
// IN COMPRESSIBILITY DIRECTION
ALPHA = .573 /G6.1
// DEFINE SOLUTION ID.
SID = DELTA-1 /G6.2
// SPECIFY GLOBAL DEFAULTS FOR FLOW PROPERTIES CALCULATIONS.
SURFACE SELECTION = UPLO /G8
PRESSURE COEFFICIENT RULES = LINEAR, SECOND-ORDER /G12
// OBTAIN ALL AVAILABLE CHECKOUT DATA.
CHECKOUT PRINTS = ALL /G17
BEGIN NETWORK DATA /N1
// GIVE NAME AND SIZE OF FIRST NETWORK.
NETWORK = WING,11,11,NEW /N2A
// SPECIFY GEOMETRY.
0.000000 0.000000 0.000000 .010000 0.000000 0.000000
.040000 0.000000 0.000000 .090000 0.000000 0.000000
.160000 0.000000 0.000000 .250000 0.000000 0.000000
.360000 0.000000 0.000000 .490000 0.000000 0.000000
.640000 0.000000 0.000000 .810000 0.000000 0.000000
1.000000 0.000000 0.000000
.010000 .005773 0.000000 .019900 .005715 0.000000
.049600 .005542 0.000000 .099100 .005253 0.000000
.168400 .004849 0.000000 .257500 .004330 0.000000
.366400 .003695 0.000000 .495100 .002944 0.000000
.643600 .002078 0.000000 .811900 .001097 0.000000
1.000000 0.000000 0.000000
.040000 .023092 0.000000 .049600 .022861 0.000000
.078400 .022168 0.000000 .126400 .021014 0.000000
.193600 .019397 0.000000 .280000 .017319 0.000000
.385600 .014779 0.000000 .510400 .011777 0.000000
.654400 .008313 0.000000 .817600 .004387 0.000000
1.000000 0.000000 0.000000
.090000 .051957 0.000000 .099100 .051437 0.000000
.126400 .049879 0.000000 .171900 .047281 0.000000
.235600 .043644 0.000000 .317500 .038968 0.000000
.417600 .033252 0.000000 .535900 .026498 0.000000
.672400 .018705 0.000000 .827100 .009872 0.000000
1.000000 0.000000 0.000000

```

Figure 4.3 - Input for test case 4A.

.160000	.092368	0.000000	.168400	.091444	0.000000
.193600	.088673	0.000000	.235600	.084055	0.000000
.294400	.077589	0.000000	.370000	.069276	0.000000
.462400	.059116	0.000000	.571600	.047108	0.000000
.697600	.033252	0.000000	.840400	.017550	0.000000
1.000000	0.000000	0.000000			
.250000	.144325	0.000000	.257500	.142882	0.000000
.280000	.138552	0.000000	.317500	.131336	0.000000
.370000	.121233	0.000000	.437500	.108244	0.000000
.520000	.092368	0.000000	.617500	.073606	0.000000
.730000	.051957	0.000000	.857500	.027422	0.000000
1.000000	0.000000	0.000000			
.360000	.207828	0.000000	.366400	.205750	0.000000
.385600	.199515	0.000000	.417600	.189123	0.000000
.462400	.174576	0.000000	.520000	.155871	0.000000
.590400	.133010	0.000000	.673600	.105992	0.000000
.769600	.074818	0.000000	.878400	.039487	0.000000
1.000000	0.000000	0.000000			
.490000	.282877	0.000000	.495100	.280048	0.000000
.510400	.271562	0.000000	.535900	.257418	0.000000
.571600	.237617	0.000000	.617500	.212158	0.000000
.673600	.181041	0.000000	.739900	.144267	0.000000
.816400	.101836	0.000000	.903100	.053747	0.000000
1.000000	0.000000	0.000000			
.640000	.369472	0.000000	.643600	.365777	0.000000
.654400	.354693	0.000000	.672400	.336220	0.000000
.697600	.310356	0.000000	.730000	.277104	0.000000
.769600	.236462	0.000000	.816400	.188431	0.000000
.870400	.133010	0.000000	.931600	.070200	0.000000
1.000000	0.000000	0.000000			
.810000	.467613	0.000000	.811900	.462937	0.000000
.817600	.448908	0.000000	.827100	.425528	0.000000
.840400	.392795	0.000000	.857500	.350710	0.000000
.878400	.299272	0.000000	.903100	.238483	0.000000
.931600	.168341	0.000000	.963900	.088846	0.000000
1.000000	0.000000	0.000000			
1.000000	.577300	0.000000	1.000000	.571527	0.000000
1.000000	.554208	0.000000	1.000000	.525343	0.000000
1.000000	.484932	0.000000	1.000000	.432975	0.000000
1.000000	.369472	0.000000	1.000000	.294423	0.000000
1.000000	.207828	0.000000	1.000000	.109687	0.000000
1.000000	0.000000	0.000000			

// NORMAL VECTOR POINTS DOWNWARD (-Z DIRECTION)
// NETWORK EDGE 1-LEADING EDGE
// NETWORK EDGE 2-TRAILING EDGE
// NETWORK EDGE 3-COLLAPSED EDGE
// NETWORK EDGE 4-INBOARD EDGE IN PLANE OF SYMMETRY

Figure 4.3 - Continued.

```

// SPECIFY ZERO TOTAL NORMAL MASS FLUX BOUNDARY CONDITION FOR THIN
// SURFACE (THIS IS A CLASS 1 B.C.)
BOUN = 1,3 /N9
STORE VIC MATRIX /N3
// DEFINE WAKE NETWORK
NETWORK = WAKE,2,11,NEW /N2A
1.000000 .577300 0.000000
2.000000 .577300 0.000000
1.000000 .571527 0.000000
2.000000 .571527 0.000000
1.000000 .554208 0.000000
2.000000 .554208 0.000000
1.000000 .525343 0.000000
2.000000 .525343 0.000000
1.000000 .484932 0.000000
2.000000 .484932 0.000000
1.000000 .432975 0.000000
2.000000 .432975 0.000000
1.000000 .369472 0.000000
2.000000 .369472 0.000000
1.000000 .294423 0.000000
2.000000 .294423 0.000000
1.000000 .207828 0.000000
2.000000 .207828 0.000000
1.000000 .109687 0.000000
2.000000 .109687 0.000000
1.000000 0.000000 0.000000
2.000000 0.000000 0.000000
BOUN = 1,4 /N9
//
BEGIN FLOW PROPERTIES DATA /FP1
SURFACE FLOW PROPERTIES = PRESSURE /SF1
// PRESSURES ARE ONLY DESIRED ON INPUT NETWORKS (NOT ON IMAGES).
// RETAIN PRESENT ORIENTATION (DO NOT USE REVERSE OPTION).
NETWORK-IMAGE = WING, INPUT, RETAIN /SF2-DEFAULT
SOLUTION = DELTA-1 /SF3-DEFAULT
// COMPUTE PRESSURES AT CENTER AND EDGE CONTROL POINTS.
POINTS = CENTER, EDGE /SF4A
// COMPUTE VELOCITY USING VIC MATRIX.
SELECTION OF VELOCITY COMP=VIC-LAMBDA /SF6
// PRINT ALL AVAILABLE ITEMS.
PRINTOUT=ALL /SF10A
DATA BASE=ALL /SF11A

```

Figure 4.3 - Continued.

```
//
FORCES AND MOMENTS      /FM1
CASE = FORCES-AND-MOMENTS  /FM7
NETWORK-IMAGE = WING, INPUT, 1ST, RETAIN  /FM8
EDGE FORCE CALCULATION = WING, 1  /FM9
SELE = VIC      /FM13
// OMIT RECORD FM21, THIS CASE NOT ADDED TO ACCUMULATION CASE
BEGIN PRINT PLOT DATA  /PP1
GEOMETRY DATA  /PP2A
NETWORKS = WING  /PP2B-DEFAULT
POINT DATA  /PP3A
NETWORKS-IMAGES = WING, INPUT  /PP3D
CONFIGURATION DATA  /PP4A
NETWORKS-IMAGES = WING, INPUT, COLSUM  /PP4D
END PROBLEM DEFINITION
```

Figure 4.3 - Concluded.

```

// PAN AIR CASE MANUAL CASE 4 (SECOND MODEL)
// YAWED DELTA WING
// LEFT LEADING EDGE (-Y) SUPERSONIC, 25 DEGREE SWEEPBACK
// RIGHT LEADING EDGE (+Y) SUBSONIC, 55 DEGREE SWEEPBACK
// TO DUPLICATE (PILOT CODE) RESULTS OF FIG. 38 OF NASA CR-3062
// AND TO DUPLICATE RESULTS OF CONICAL FLOW
// REF. JONES AND COHEN, TABLE A,13A-NUMBER 8
  BEGIN GLOBAL DATA /G1
  PID=CASE YDW, YAWED DELTA WING - M=1.414
  UID=USER IDENTIFICATION
  CONFIGURATION = ASYMMETRIC-GEOMETRY /G4
  MACH = 1.414 /G5
  ALPHA = .573 /G6.1
  SID = SOLN-1 /G6.2
  TOLE = .00005 /G7
  SURFACE SELECTION = UPPER UPLO /G8
  PRESSURE COEF RULES = ISENTROPIC, LINEAR, SECOND-ORDER /G12
  CHEC = DIP 1 2 3, DQG 1 4 5 6 /G17
  BEGIN NETWORK DATA /N1
  NETWORK=WING,21,7,NEW /N2A
  0.,0.,0. 0.,0.,0. 0.,0.,0. 0.,0.,0. 0.,0.,0. 0.,0.,0. 0.,0.,0.
  0.,0.,0. 0.,0.,0. 0.,0.,0. 0.,0.,0. 0.,0.,0. 0.,0.,0. 0.,0.,0.
  0.,0.,0. 0.,0.,0. 0.,0.,0. 0.,0.,0. 0.,0.,0. 0.,0.,0. 0.,0.,0.
    .09427  -.20217  0.00000  .09427  -.16329  0.00000
    .09427  -.13464  0.00000  .09427  -.11235  0.00000
    .09427  -.09427  0.00000  .09427  -.07910  0.00000
    .09427  -.06601  0.00000  .09427  -.05443  0.00000
    .09427  -.04396  0.00000  .09427  -.03431  0.00000
    .09427  -.02526  0.00000  .09427  -.01662  0.00000
    .09427  -.00825  0.00000  .09427  0.00000  0.00000
    .09427  .00825  0.00000  .09427  .01662  0.00000
    .09427  .02526  0.00000  .09427  .03431  0.00000
    .09427  .04396  0.00000  .09427  .05443  0.00000
    .09427  .06601  0.00000
    .18855  -.40434  0.00000  .18855  -.32657  0.00000
    .18855  -.26927  0.00000  .18855  -.22470  0.00000
    .18855  -.18855  0.00000  .18855  -.15821  0.00000
    .18855  -.13202  0.00000  .18855  -.10886  0.00000
    .18855  -.08792  0.00000  .18855  -.06862  0.00000
    .18855  -.05052  0.00000  .18855  -.03325  0.00000
    .18855  -.01650  0.00000  .18855  0.00000  0.00000
    .18855  .01650  0.00000  .18855  .03325  0.00000
    .18855  .05052  0.00000  .18855  .06862  0.00000
    .18855  .08792  0.00000  .18855  .10886  0.00000
    .18855  .13202  0.00000

```

Figure 4.4 - Input for test case 4B

.28282	-.60651	0.00000	.28282	-.48986	0.00000
.28282	-.40391	0.00000	.28282	-.33705	0.00000
.28282	-.28282	0.00000	.28282	-.23731	0.00000
.28282	-.19803	0.00000	.28282	-.16329	0.00000
.28282	-.13188	0.00000	.28282	-.10294	0.00000
.28282	-.07578	0.00000	.28282	-.04987	0.00000
.28282	-.02474	0.00000	.28282	0.00000	0.00000
.28282	.02474	0.00000	.28282	.04987	0.00000
.28282	.07578	0.00000	.28282	.10294	0.00000
.28282	.13188	0.00000	.28282	.16329	0.00000
.28282	.19803	0.00000			
.37709	-.80867	0.00000	.37709	-.65314	0.00000
.37709	-.53854	0.00000	.37709	-.44940	0.00000
.37709	-.37709	0.00000	.37709	-.31642	0.00000
.37709	-.26404	0.00000	.37709	-.21771	0.00000
.37709	-.17584	0.00000	.37709	-.13725	0.00000
.37709	-.10104	0.00000	.37709	-.06649	0.00000
.37709	-.03299	0.00000	.37709	0.00000	0.00000
.37709	.03299	0.00000	.37709	.06649	0.00000
.37709	.10104	0.00000	.37709	.13725	0.00000
.37709	.17584	0.00000	.37709	.21771	0.00000
.37709	.26404	0.00000			
.47136	-1.01084	0.00000	.47136	-.81643	0.00000
.47136	-.67318	0.00000	.47136	-.56175	0.00000
.47136	-.47136	0.00000	.47136	-.39552	0.00000
.47136	-.33005	0.00000	.47136	-.27214	0.00000
.47136	-.21980	0.00000	.47136	-.17156	0.00000
.47136	-.12630	0.00000	.47136	-.08311	0.00000
.47136	-.04124	0.00000	.47136	0.00000	0.00000
.47136	.04124	0.00000	.47136	.08311	0.00000
.47136	.12630	0.00000	.47136	.17156	0.00000
.47136	.21980	0.00000	.47136	.27214	0.00000
.47136	.33005	0.00000			
.56564	-1.21301	0.00000	.56564	-.97971	0.00000
.56564	-.80781	0.00000	.56564	-.67410	0.00000
.56564	-.56564	0.00000	.56564	-.47463	0.00000
.56564	-.39606	0.00000	.56564	-.32657	0.00000
.56564	-.26376	0.00000	.56564	-.20587	0.00000
.56564	-.15156	0.00000	.56564	-.09974	0.00000
.56564	-.04949	0.00000	.56564	0.00000	0.00000
.56564	.04949	0.00000	.56564	.09974	0.00000
.56564	.15156	0.00000	.56564	.20587	0.00000
.56564	.26376	0.00000	.56564	.32657	0.00000
.56564	.39606	0.00000			

// NORMAL VECTOR POINTS UPWARD (+Z DIRECTION)

Figure 4.4 - Continued.

```

// NETWORK EDGE 1-LEFT LEADING EDGE
// NETWORK EDGE 2-TRAILING EDGE
// NETWORK EDGE 3-RIGHT LEADING EDGE
// NETWORK EDGE 4-TRUNCATED APEX OF WING
BOUNDARY CONDITION = 1, 3 /N9
// END OF DATA FOR NETWORK WING
NETWORK = WAKE,2,21,NEW /N2A
.56564 -1.21301 0.00000
1.56564 -1.21301 0.00000
.56564 -.97971 0.00000
1.56564 -.97971 0.00000
.56564 -.80781 0.00000
1.56564 -.80781 0.00000
.56564 -.67410 0.00000
1.56564 -.67410 0.00000
.56564 -.56564 0.00000
1.56564 -.56564 0.00000
.56564 -.47463 0.00000
1.56564 -.47463 0.00000
.56564 -.39606 0.00000
1.56564 -.39606 0.00000
.56564 -.32657 0.00000
1.56564 -.32657 0.00000
.56564 -.26376 0.00000
1.56564 -.26376 0.00000
.56564 -.20587 0.00000
1.56564 -.20587 0.00000
.56564 -.15156 0.00000
1.56564 -.15156 0.00000
.56564 -.09974 0.00000
1.56564 -.09974 0.00000
.56564 -.04949 0.00000
1.56564 -.04949 0.00000
.56564 0.00000 0.00000
1.56564 0.00000 0.00000
.56564 .04949 0.00000
1.56564 .04949 0.00000
.56564 .09974 0.00000
1.56564 .09974 0.00000
.56564 .15156 0.00000
1.56564 .15156 0.00000
.56564 .20587 0.00000
1.56564 .20587 0.00000
.56564 .26376 0.00000
1.56564 .26376 0.00000
.56564 .32657 0.00000
1.56564 .32657 0.00000
.56564 .39606 0.00000
1.56564 .39606 0.00000

```

Figure 4.4 - Continued.

```

// NORMAL VECTOR POINTS DOWNWARD (-Z DIRECTION)
// NORMAL EDGE 1-LEADING EDGE
// NORMAL EDGE 2-RIGHT EDGE
// NORMAL EDGE 3-TRAILING EDGE
// NORMAL EDGE 4-LEFT EDGE
BOUN = 1,4 /N9
// END OF DATA FOR NETWORK WAKE
//
BEGIN FLOW PROPERTIES DATA /FP1
// SURFACE FLOW PROPERTIES CASE 1
SURFACE FLOW PROP=CASE-A
// OMIT RECORD SF2, DEFAULT IS ALL NON-WAKE (I.E., WING) NETWORKS
// OMIT RECORD SF3, DEFAULT IS ALL (I.E., FIRST) SOLUTION
POINTS=CENTER /SF4A-DEFAULT
PRINTOUT=ALL /SF10A
DATA BASE=ALL /SF11A
FORCES AND MOMENTS /FM1
// SET SR=0.01 FOR PRINTING ADDED SIGNIFICANT FIGURES
REFERENCE PARAMETERS = SR .01 /FM2
CASE=FORCES-AND-MOMENTS /FM7
NETWORKS-IMAGES=WING,RETAIN /FM8-DEFAULT
EDGE FORCE CALCULATION=WING, 3 /FM9
SURFACE SELECTION=UPLO /FM12
BEGIN PRINT PLOT DATA /PP1
GEOMETRY DATA /PP2A
NETWORKS = WING /PP2D-DEFAULT
POINT DATA /PP3A
NETWORKS-IMAGES = WING /PP3D-DEFAULT
CONFIGURATION DATA /PP4A
NETWORKS-IMAGES = WING, COLSUM /PP4D-DEFAULT
END PROBLEM DEFINITION

```

Figure 4.4 - Concluded.

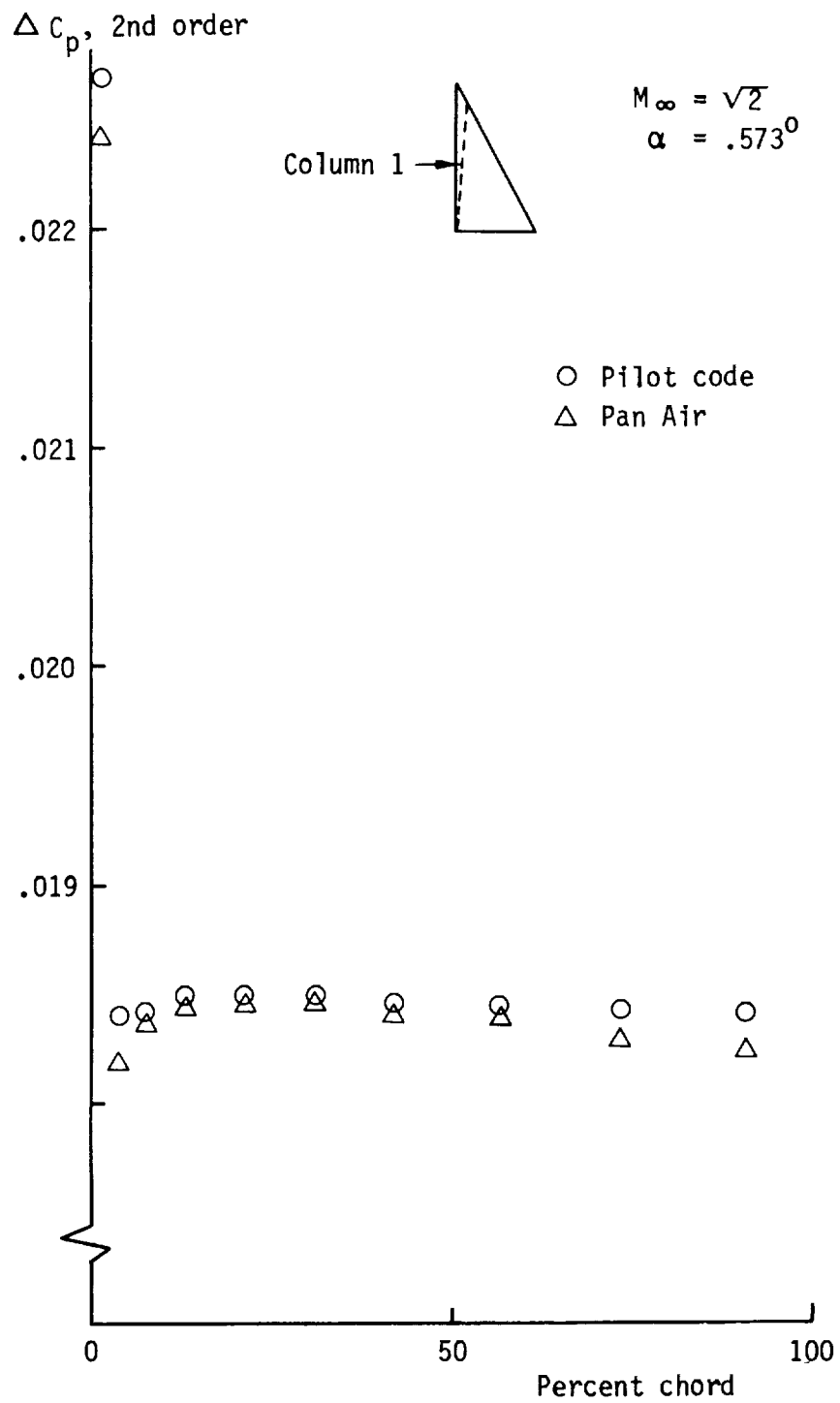

(a) Column 1 of panel center control points.

Figure 4.5 - Comparison of Predicted Pressures for Symmetric Delta Wing

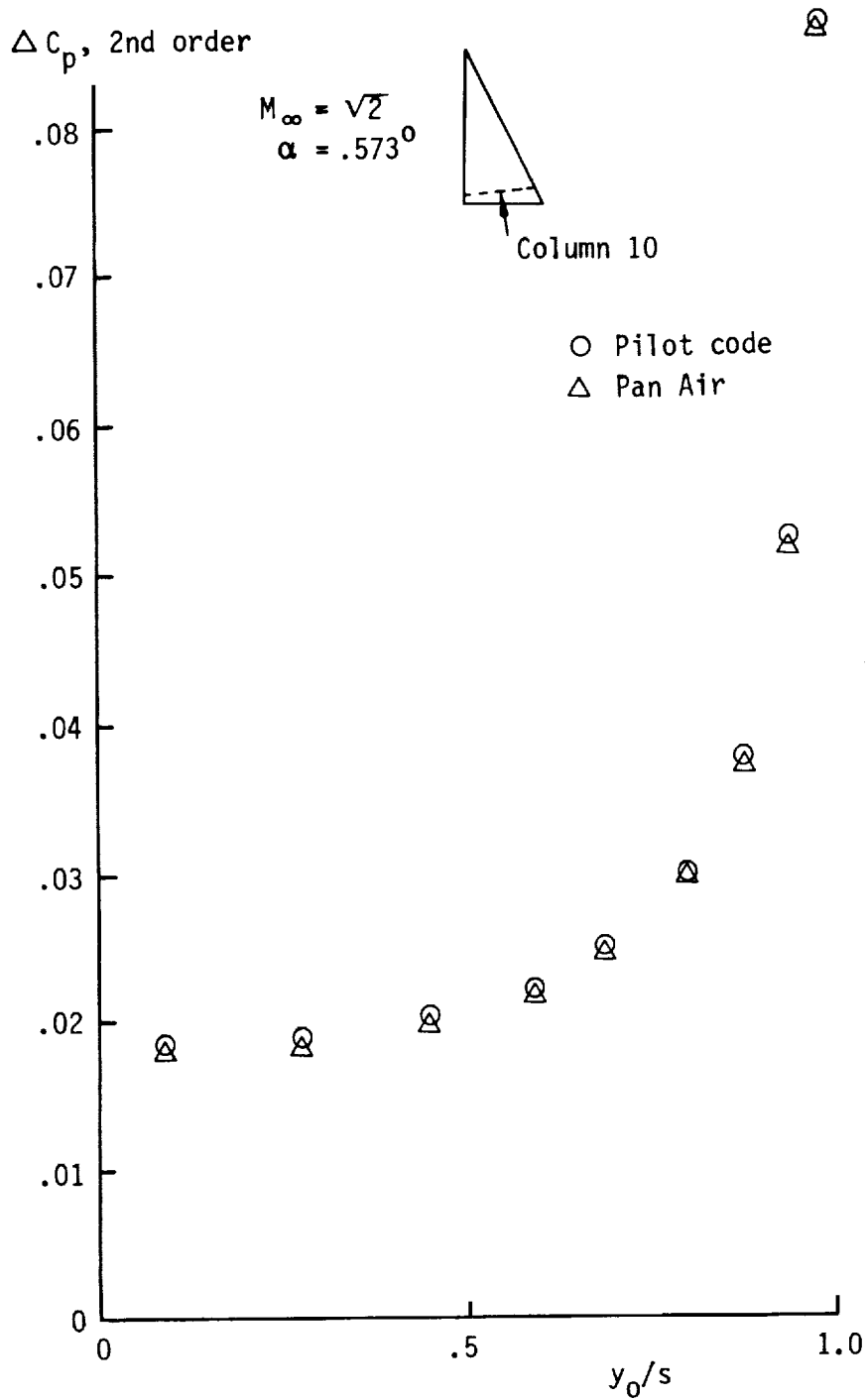

(b) Column 10 of panel center control points

C_p , 2nd order, upper surface

$M_\infty = 2$
 $\alpha = .573^\circ$
 $x_0 = .5185$

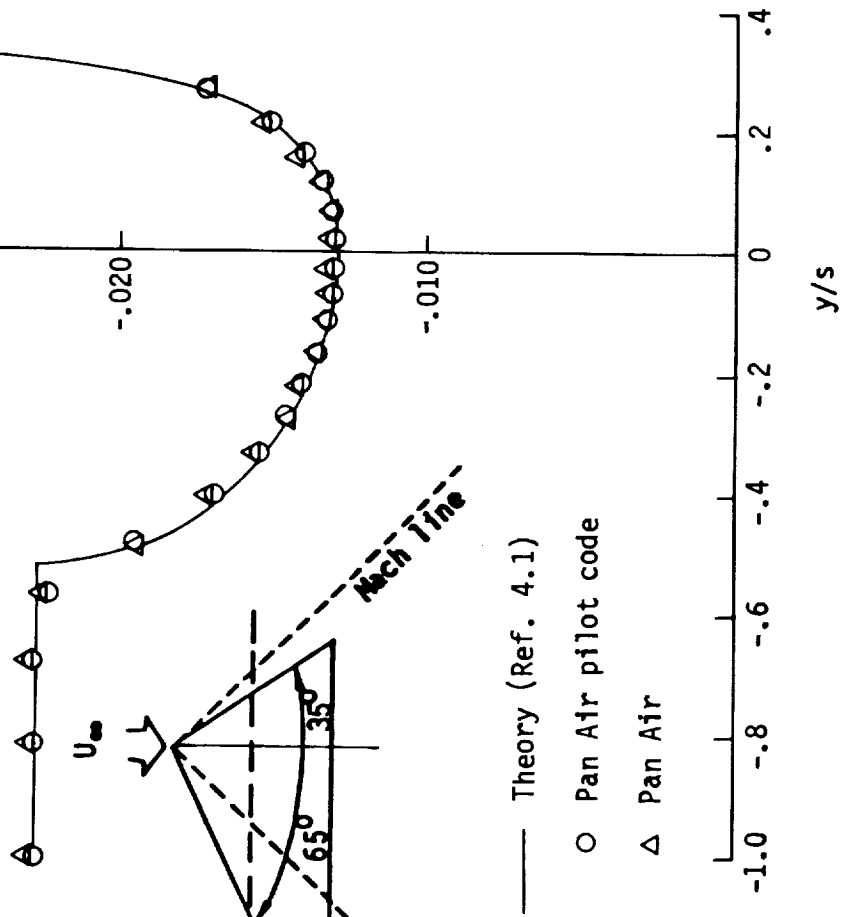

Figure 4.6 - Comparison of pressure distributions predicted for a yawed delta wing



5. NASA WING-BODY

Purpose

The purpose of this case is to illustrate the use of the two planes of symmetry option for a thick wing-body in supersonic flow, using zero perturbation potential boundary conditions.

Configuration, Flow, and Modeling

The configuration is described in ref. 5.1, and its the plan view is illustrated in figure 5.1. Only a quarter of the geometry needs to be defined, since the configuration has two planes of geometric symmetry. Four networks are used to define the configuration: one for the forebody; one for the midbody; one for the wing; and a wake network for the remainder of the body.

A schematic of the four input networks and the program-created 3rd image networks (see figure 7.11 in the PAN AIR User's Manual) is shown in figure 5.2. For the three fuselage networks the N direction is streamwise and the M direction points circumferentially, starting at the top of the fuselage. For the wing network the N direction is streamwise and the M direction is spanwise. Thus, for each network NxM points out into the physical flow and so the network's "upper" surfaces are wetted by the physical flow.

The flow is supersonic ($M = 2.01$) and the configuration is being analyzed at zero angles of attack and sideslip. The leading edge of the wing is supersonic and, thus, a disturbance propagates downstream across the wing on the Mach line emanating from the junction of the body with the leading edge of the wing, as shown in figure 5.1.

The panels of both the wing and the body are on the exact configuration surface. Class 1, subclass 1 boundary conditions for analyzing a thick configuration (i.e., zero internal perturbation potential and indirect specification of zero normal flow) are used.

Generally, a wake network would be required to prevent the doublet strength on the wing from going to zero at its trailing edge. In this nonlifting case, however, the doublet strength is known to equal zero (at the trailing edges of both the real network and its image across the x_0 - y_0 plane), and, therefore, the wake may be omitted. A type DW1 wake network would be required if a non-zero angle of attack were imposed. The body wake is required, however, because the body doublet strength is not necessarily zero at the trailing edge.

Another network which is omitted is a network to seal off the tip of the wing. Experience has shown that when zero perturbation potential boundary conditions (class 1, subclass 1 or 2) are used, no significant changes in the solution on the wing occur (except for pressures very near the tip) when a tip network is omitted.

Input

The input is shown in figure 5.3. Record G4 specifies that there are two planes of configuration symmetry, both of which are planes of flow symmetry. Since the geometric edge matching records are not input, the "automatic abutment search" is relied upon to locate abutting networks. Finally, there is one case each for flow properties data and force and moment data.

Results and Discussion

Figure 5.4 compares upper surface wing pressures predicted by PAN AIR with pressures predicted by the PAN AIR pilot code (see INTRODUCTION for references) for the second row of wing panels (Note that in this case a streamwise sequence of panels form a row rather than a column). The existence of the disturbance crossing the wing insures that the pressure distribution on the wing surface is not smooth, and, consequently, software errors in certain portions of the code, if existent, would probably tend to produce results that differ significantly from pilot code results. Therefore, the closeness of these results is assumed to adequately verify these certain portions of PAN AIR. In particular, source and doublet potential influence coefficient calculation and source and doublet spline construction are assumed to be verified.

Figure 5.5 compares results predicted by the PAN AIR pilot code (figure 75 of reference 5.2) with experimental results from reference 5.1. The pilot code results in figure 5.5 were obtained with denser paneling than for the results in figure 5.4.

REFERENCES

- 5.1 Gopcynski, J. P.; and Landrum, E. J.: Tabulated Data from a Pressure-Distribution Investigation at Mach Number 2.01 of a 45° Sweptback-Wing Airplane Model at Combined Angles of Attack and Sideslip. NASA Memorandum 10-15-58L, 1958.
- 5.2 Ehlers, Edward F.; Epton, Michael A.; Johnson, Forrester T.; Magnus, Alfred E.; and Rubbert, Paul E.: A Higher Order Panel Method for Linearized Supersonic Flow. NASA CR-3062, May 1979.

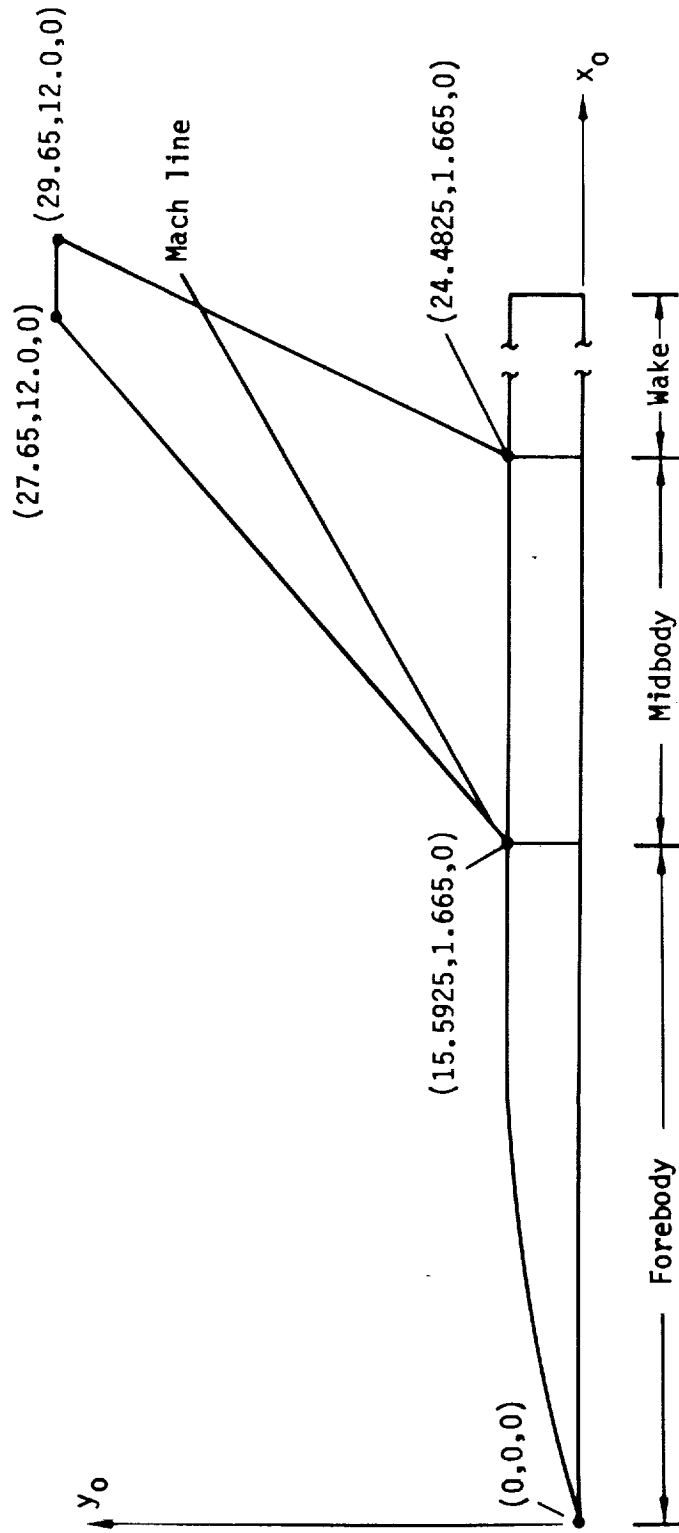

Figure 5.1 - The wing/body of NASA Memo 10-15-58L with two planes of symmetry

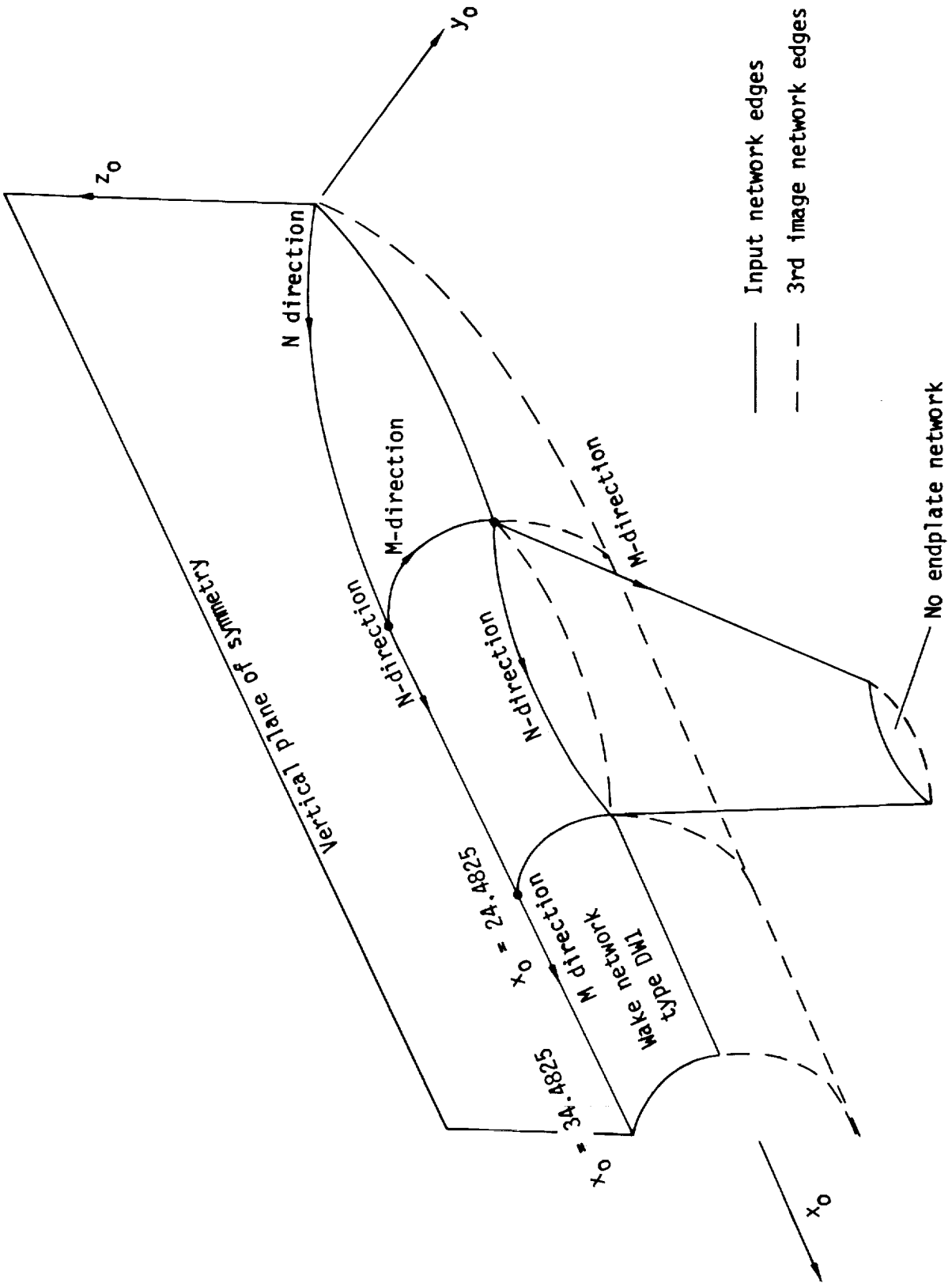

Figure 5.2 - Schematic of input & 3rd image networks

```

// PAN AIR CASE MANUAL CASE 5
BEGIN GLOBAL DATA /G1
PID=NASA WING-BODY WITH TWO PLANES OF SYMMETRY
UID=PANAIR
CONF = FIRST,SECOND, 0., 0., 1., SYMM /G4
MACH = 2.01 /G5
SID = SOL-1 /G6.1
ALPH = 0. /G6.2
SURF = UPPER /G8
PRES = ISEN,SECOND /G12
TOLE = .000001 /G7
CHEC = DIP, 1, 2, 3, DQG, 1, 2, 4, 5, 6 /G17
//
BEGI NETW DATA /N1
NETWORK = FOREBODY,8,11,NEW /N2A
0.000000 0.000000 0.000000 0.000000 0.000000 0.000000
0.000000 0.000000 0.000000 0.000000 0.000000 0.000000
0.000000 0.000000 0.000000 0.000000 0.000000 0.000000
0.000000 0.000000 0.000000 0.000000 0.000000 0.000000
1.458750 0.000000 .396382 1.458750 .088203 .386444
1.458750 .171984 .357128 1.458750 .247140 .309904
1.458750 .309904 .247140 1.458750 .357128 .171984
1.458750 .386444 .088203 1.458750 .396382 0.000000
2.917500 0.000000 .736799 2.917500 .163953 .718326
2.917500 .319685 .663833 2.917500 .459386 .576052
2.917500 .576052 .459386 2.917500 .663833 .319685
2.917500 .718326 .163953 2.917500 .736799 0.000000
4.376250 0.000000 1.022640 4.376250 .227559 .997001
4.376250 .443707 .921367 4.376250 .637606 .799532
4.376250 .799532 .637606 4.376250 .921367 .443707
4.376250 .997001 .227559 4.376250 1.022640 0.000000
5.835000 0.000000 1.255040 5.835000 .279273 1.223574
5.835000 .544542 1.130752 5.835000 .782505 .981230
5.835000 .981230 .782505 5.835000 1.130752 .544542
5.835000 1.223574 .279273 5.835000 1.255040 0.000000
7.293750 0.000000 1.434896 7.293750 .319294 1.398920
7.293750 .622578 1.292797 7.293750 .894643 1.121847
7.293750 1.121847 .894643 7.293750 1.292797 .622578
7.293750 1.398920 .319294 7.293750 1.434896 0.000000
8.752500 0.000000 1.562889 8.752500 .347775 1.523704
8.752500 .678112 1.408114 8.752500 .974445 1.221915
8.752500 1.221915 .974445 8.752500 1.408114 .678112
8.752500 1.523704 .347775 8.752500 1.562889 0.000000
10.211250 0.000000 1.639496 10.211250 .364822 1.598390
10.211250 .711350 1.477134 10.211250 1.022209 1.281809
10.211250 1.281809 1.022209 10.211250 1.477134 .711350

```

Figure 5.3 - Input for test case 5.

10.211250	1.598390	.364822	10.211250	1.639496	0.000000
11.670000	0.000000	1.665000	11.670000	.370497	1.623255
11.670000	.722416	1.500113	11.670000	1.038111	1.301749
11.670000	1.301749	1.038111	11.670000	1.500113	.722416
11.670000	1.623255	.370497	11.670000	1.665000	0.000000
13.631250	0.000000	1.665000	13.631250	.370497	1.623255
13.631250	.722416	1.500113	13.631250	1.038111	1.301749
13.631250	1.301749	1.038111	13.631250	1.500113	.722416
13.631250	1.623255	.370497	13.631250	1.665000	0.000000
15.592500	0.000000	1.665000	15.592500	.370497	1.623255
15.592500	.722416	1.500113	15.592500	1.038111	1.301749
15.592500	1.301749	1.038111	15.592500	1.500113	.722416
15.592500	1.623255	.370497	15.592500	1.665000	0.000000
BOUN = OVER, 1, 1 /N9					
NETW = MIDBODY, 8, 11 ,NEW /N2A					
15.592500	0.000000	1.665000	15.592500	.370497	1.623255
15.592500	.722416	1.500113	15.592500	1.038111	1.301749
15.592500	1.301749	1.038111	15.592500	1.500113	.722416
15.592500	1.623255	.370497	15.592500	1.665000	0.000000
16.481500	0.000000	1.665000	16.481500	.370497	1.623255
16.481500	.722416	1.500113	16.481500	1.038111	1.301749
16.481500	1.301749	1.038111	16.481500	1.500113	.722416
16.481500	1.623255	.370497	16.477634	1.661485	.108131
17.370500	0.000000	1.665000	17.370500	.370497	1.623255
17.370500	.722416	1.500113	17.370500	1.038111	1.301749
17.370500	1.301749	1.038111	17.370500	1.500113	.722416
17.370500	1.623255	.370497	17.363803	1.658519	.146765
18.259500	0.000000	1.665000	18.259500	.370497	1.623255
18.259500	.722416	1.500113	18.259500	1.038111	1.301749
18.259500	1.301749	1.038111	18.259500	1.500113	.722416
18.259500	1.623255	.370497	18.251225	1.656440	.168618
19.148500	0.000000	1.665000	19.148500	.370497	1.623255
19.148500	.722416	1.500113	19.148500	1.038111	1.301749
19.148500	1.301749	1.038111	19.148500	1.500113	.722416
19.148500	1.623255	.370497	19.139941	1.655490	.177704
20.037500	0.000000	1.665000	20.037500	.370497	1.623255
20.037500	.722416	1.500113	20.037500	1.038111	1.301749
20.037500	1.301749	1.038111	20.037500	1.500113	.722416
20.037500	1.623255	.370497	20.029968	1.655962	.173250
20.926500	0.000000	1.665000	20.926500	.370497	1.623255
20.926500	.722416	1.500113	20.926500	1.038111	1.301749
20.926500	1.301749	1.038111	20.926500	1.500113	.722416
20.926500	1.623255	.370497	20.921049	1.657891	.153701
21.815500	0.000000	1.665000	21.815500	.370497	1.623255
21.815500	.722416	1.500113	21.815500	1.038111	1.301749
21.815500	1.301749	1.038111	21.815500	1.500113	.722416
21.815500	1.623255	.370497	21.812323	1.660461	.122857
22.704500	0.000000	1.665000	22.704500	.370497	1.623255

Figure 5.3 - Continued.

22.704500	.722416	1.500113	22.704500	1.038111	1.301749
22.704500	1.301749	1.038111	22.704500	1.500113	.722416
22.704500	1.623255	.370497	22.703145	1.662861	.084380
23.593500	0.000000	1.665000	23.593500	.370497	1.623255
23.593500	.722416	1.500113	23.593500	1.038111	1.301749
23.593500	1.301749	1.038111	23.593500	1.500113	.722416
23.593500	1.623255	.370497	23.593190	1.664453	.042674
24.482500	0.000000	1.665000	24.482500	.370497	1.623255
24.482500	.722416	1.500113	24.482500	1.038111	1.301749
24.482500	1.301749	1.038111	24.482500	1.500113	.722416
24.482500	1.623255	.370497	24.482500	1.665000	0.000000
NETW = WING, 12, 11 ,NEW /N2A					
15.592500	1.665000	0.000000	17.308461	3.135824	0.000000
18.989490	4.576706	0.000000	20.601367	5.958314	0.000000
22.111277	7.252523	0.000000	23.488483	8.432986	0.000000
24.704950	9.475672	0.000000	25.735914	10.359355	0.000000
26.560388	11.066047	0.000000	27.161587	11.581360	0.000000
27.527272	11.894805	0.000000	27.650000	12.000000	0.000000
16.477634	1.661485	.108131	18.099406	3.135824	.096179
19.684377	4.576706	.084498	21.204146	5.958314	.073298
22.627775	7.252523	.062806	23.926284	8.432986	.053237
25.073239	9.475672	.044784	26.045291	10.359355	.037620
26.822651	11.066047	.031891	27.389496	11.581360	.027714
27.734285	11.894805	.025173	27.850000	12.000000	.024320
17.363803	1.658519	.146765	18.890351	3.135824	.130514
20.379263	4.576706	.114663	21.806925	5.958314	.099465
23.144274	7.252523	.085227	24.364085	8.432986	.072242
25.441528	9.475672	.060771	26.354667	10.359355	.051050
27.084915	11.066047	.043276	27.617405	11.581360	.037607
27.941298	11.894805	.034159	28.050000	12.000000	.033002
18.251225	1.656440	.168618	19.681296	3.135824	.149924
21.074149	4.576706	.131716	22.409704	5.958314	.114257
23.660772	7.252523	.097902	24.801886	8.432986	.082985
25.809816	9.475672	.069809	26.664043	10.359355	.058642
27.347178	11.066047	.049712	27.845315	11.581360	.043200
28.148311	11.894805	.039239	28.250000	12.000000	.037910
19.139941	1.655490	.177704	20.472241	3.135824	.157991
21.769035	4.576706	.138804	23.012483	5.958314	.120405
24.177271	7.252523	.103171	25.239687	8.432986	.087451
26.178105	9.475672	.073566	26.973420	10.359355	.061798
27.609442	11.066047	.052387	28.073224	11.581360	.045525
28.355324	11.894805	.041351	28.450000	12.000000	.039950
20.029968	1.655962	.173250	21.263187	3.135824	.154037
22.463922	4.576706	.135329	23.615262	5.958314	.117391
24.693769	7.252523	.100588	25.677488	8.432986	.085262
26.546393	9.475672	.071724	27.282796	10.359355	.060251
27.871706	11.066047	.051076	28.301133	11.581360	.044385
28.562337	11.894805	.040316	28.650000	12.000000	.038950

Figure 5.3 - Continued.

```

20.921049 1.657891 .153701 22.054132 3.135824 .136675
23.158808 4.576706 .120076 24.218041 5.958314 .104160
25.210268 7.252523 .089251 26.115289 8.432986 .075652
26.914682 9.475672 .063640 27.592172 10.359355 .053460
28.133969 11.066047 .045319 28.529043 11.581360 .039383
28.769350 11.894805 .035772 28.850000 12.000000 .034560
21.812323 1.660461 .122857 22.845077 3.135824 .109269
23.853694 4.576706 .095999 24.820820 5.958314 .083274
25.726766 7.252523 .071354 26.553090 8.432986 .060482
27.282970 9.475672 .050879 27.901549 10.359355 .042740
28.396233 11.066047 .036232 28.756952 11.581360 .031486
28.976363 11.894805 .028599 29.050000 12.000000 .027630
22.703145 1.662861 .084380 23.636022 3.135824 .075061
24.548580 4.576706 .065945 25.423599 5.958314 .057204
26.243264 7.252523 .049016 26.990891 8.432986 .041547
27.651259 9.475672 .034951 28.210925 10.359355 .029360
28.658496 11.066047 .024889 28.984861 11.581360 .021629
29.183376 11.894805 .019646 29.250000 12.000000 .018980
23.593190 1.664453 .042674 24.426967 3.135824 .037965
25.243467 4.576706 .033355 26.026378 5.958314 .028933
26.759763 7.252523 .024792 27.428692 8.432986 .021014
28.019547 9.475672 .017678 28.520301 10.359355 .014850
28.920760 11.066047 .012589 29.212771 11.581360 .010940
29.390389 11.894805 .009937 29.450000 12.000000 .009600
24.482500 1.665000 0.000000 25.217912 3.135824 0.000000
25.938353 4.576706 0.000000 26.629157 5.958314 0.000000
27.276261 7.252523 0.000000 27.866493 8.432986 0.000000
28.387836 9.475672 0.000000 28.829678 10.359355 0.000000
29.183023 11.066047 0.000000 29.440680 11.581360 0.000000
29.597402 11.894805 0.000000 29.650000 12.000000 0.000000
// BODY NEEDS WAKE EVEN THOUGH ANGLE OF ATTACK IS ZERO
NETWORK = BODY-WAKE,2,8,NEW /N2A
24.4825 0. 1.665 34.4825 0. 1.665
24.4825 .370497 1.623255 34.4825 .370497 1.623255
24.4825 .722416 1.500113 34.4825 .722416 1.500113
24.4825 1.038111 1.301749 34.4825 1.038111 1.301749
24.4825 1.301749 1.038111 34.4825 1.301749 1.038111
24.4825 1.500113 .722416 34.4825 1.500113 .722416
24.4825 1.623255 .370497 34.4825 1.623255 .370497
24.4825 1.665 0. 34.4825 1.665 0.
BOUN = 1,4 /N9
//

```

Figure 5.3 - Continued

```

BEGIN FLOW /FP1
//
SURF FLOW = PRESSURE /SF1
NETWORKS-IMAGES= FOREBODY, INPUT=MIDBODY, INPUT=WING, INPUT /SF2
POINT = CENTER /SF4A
PRINT = ALL /SF10A
DATA BASE=ALL /SF11A
//
FORCES AND MOMENTS /FM1
AXIS = RCS /FM3
CASE = FM /FM7
NETWORKS-IMAGES= FOREBODY, INPUT=MIDBODY, INPUT=WING, INPUT /FM8
BEGIN PRINT PLOT DATA /PP1
GEOMETRY DATA /PP2A
NETWORKS = FOREBODY, MIDBODY, WING /PP2B
POINT DATA /PP3A
NETWORKS-IMAGES =FOREBODY, INPUT =MIDBODY, INPUT =WING, INPUT /PP3D
CONFIGURATION DATA /PP4A
NETWORKS-IMAGES =FOREBODY, INPUT =MIDBODY, INPUT =WING, INPUT, COLSUM /PP4D
END PROB DEF

```

Figure 5.3 - Concluded.

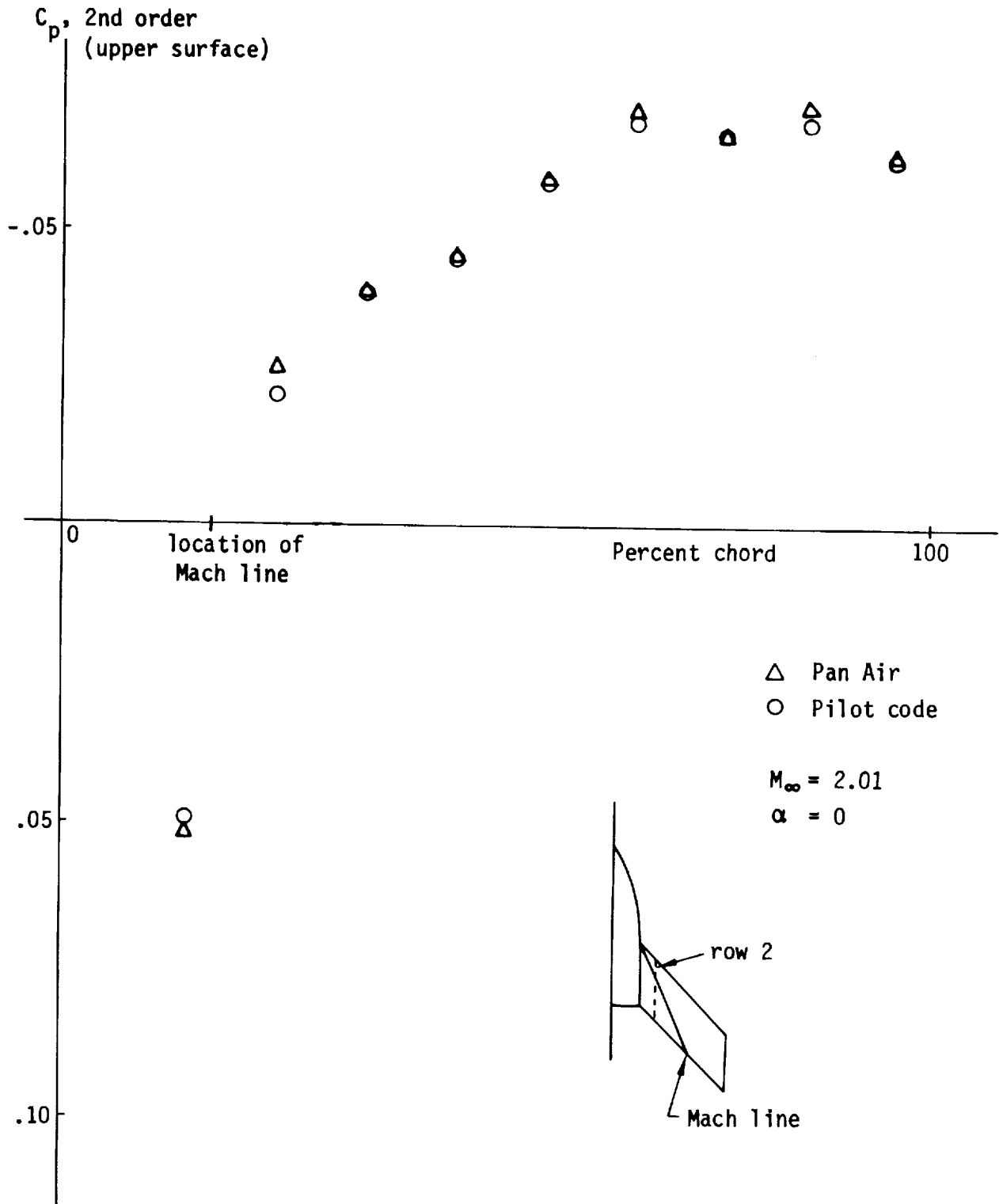

Figure 5.4 - Comparison of pilot code and PAN AIR pressures on wing of NASA wing-body

$M = 2.01$ $\alpha = \beta = 0$
 — Experiment (Ref. [5.1])
 Δ PAN AIR pilot code

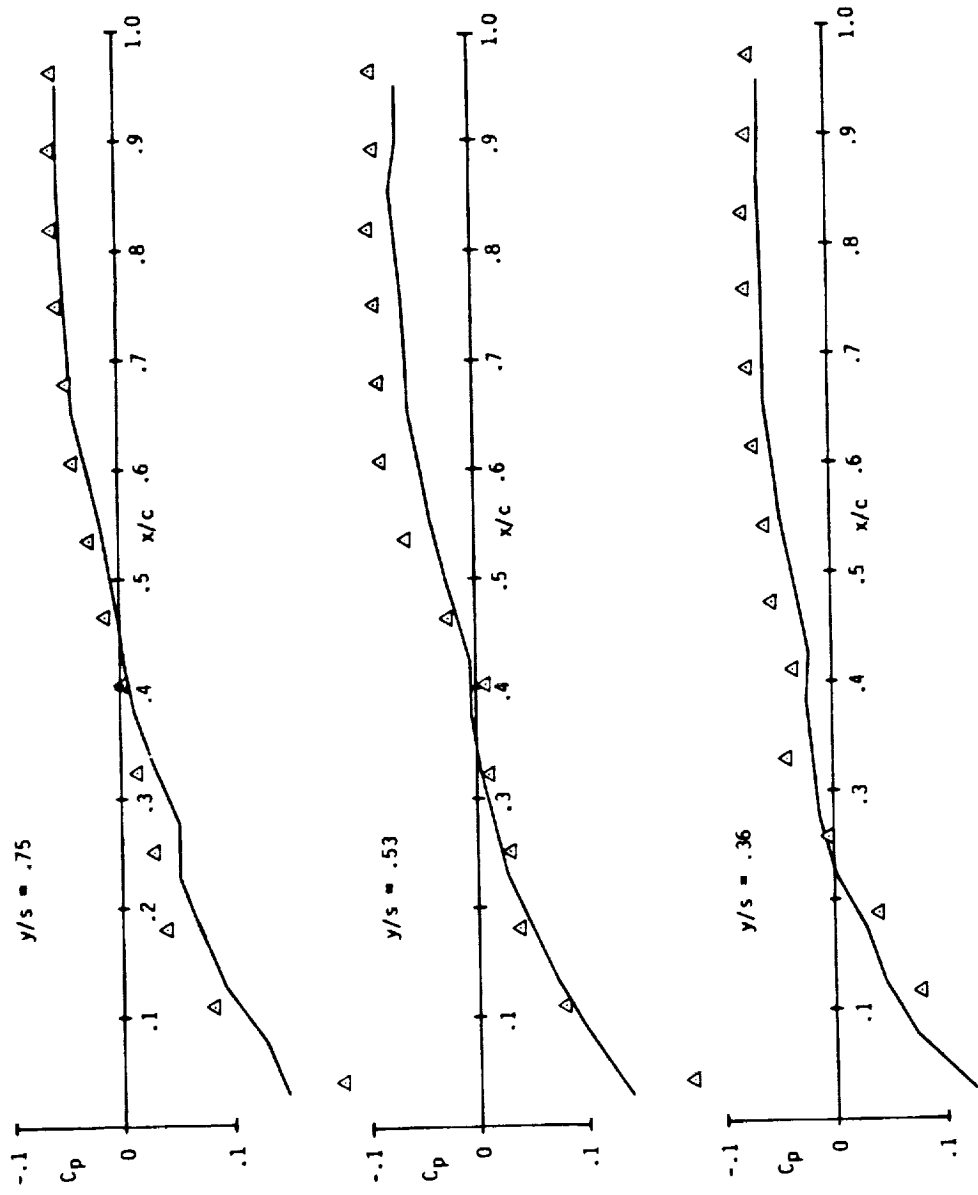

Figure 5.5 - Pressure Distribution on The Wing of The Symmetrical Wing/body of NASA Memo 10-15-58L

6 THIN WING WITH DEFLECTED FLAP

Purpose

The purpose of this case is to test the ability of PAN AIR to analyze in subsonic flow an infinitely thin wing with deflected flap and with boundary conditions specified on the true deflected flap surface and to further test the specified flow and local onset flow options.

Configuration, Flow, and Modeling

The configuration plan view is illustrated in figure 6.1. The wing has zero thickness, and the flap is geometrically deflected. The choice of the exact flap deflection model for this PAN AIR case was based on the desire to test certain influence coefficient calculations done only when a nonplanar singularity surface is used.

The wing and flap are divided into six networks, as shown in figure 6.2, with standard thin surface impermeability boundary conditions imposed. The configuration also has eleven wake networks, the boundaries of which are shown as dotted lines in figure 6.2. There are three wakes emanating from the wing and flap, two filler wakes in each of the two gaps between wing and flap, and four additional wake networks emanating from the trailing edges of the filler wakes*. All wake networks are defined to be type DW1 networks.

The Mach number is 0.6, and the angle of attack of the wing is 0° . The wing network is in the x_0 - y_0 plane, and, therefore, any pressure distribution on the planar wing is a result of the 10° flap deflection.

*Editor's note: In the editor's opinion, the modelling would be more physically realistic if wake networks 10 and 12 were replaced by one type 2 wake network with its first corner point being at the intersection of networks 1, 2, 4 and 5. This is because the wake shed from the outboard side edge of network 4 would not roll under the wing. Also, networks 15 and 17 should be replaced by one type 2 wake network in a similar manner.

Input

The input is shown in figure 6.3. From the order of input for the geometry and from figure 6.2 it can be seen that the network normals for the wing and flap networks have negative z_0 components. All abutments are specified. The first abutment record, for instance, instructs the program that edge 2 of network A1 abuts edge 4 of network A2. The abutments have been specified to decrease processing costs. Almost all options for surface flow property data are the defaults, except that the VIC method is used for the surface velocity and pressure computation because it is generally more accurate than the BOUNDARY-CONDITION method. There are three solutions. In solution 1, the actual geometrically deflected flap is analyzed. The last two solutions consist of a specified flow and a local onset flow, respectively, both of which are used to reset the flap to an undeflected state via boundary conditions only (i.e., the flap is still geometrically deflected), and both of which should result in zero singularity strengths for all networks since the angle of attack is zero (by default). These boundary conditions are input the same as the boundary conditions for models (b) and (c), respectively, in section 2 of this document.

Results and Conclusions

Figure 6.4 compares PAN AIR results for solution 1 with experiment (reference 6.1) and with a kernel function method capable of accurately predicting the logarithmic pressure coefficient singularity known to occur at the flap hingeline (reference 6.2). The figure compares the lifting pressure distribution at a spanwise station near the mid-span of the flap. The two theoretical methods agree quite well, except that PAN AIR deviates somewhat from the kernel function method at the panel closest to the leading edge and at the panel just ahead of the hingeline. Since PAN AIR forces the doublet strength to vary quadratically over any panel, it can not be expected to give accurate results at the panel closest to free network edges or surface slope discontinuities, where the doublet strength is not well approximated by a quadratic curve. In other words, PAN AIR results do not usually converge uniformly at free network edges or surface slope discontinuities. The effects of this nonuniform convergence on overall forces and moments or on local conditions at any given, fixed point can be ameliorated by increasing the panel density, but the doublet strength distribution (and, hence, the pressure distribution) on the panel closest to free network edges and surface slope discontinuities can always be expected to be in error.

PAN AIR predicted a lift coefficient of 0.176, while the kernel function method predicted 0.197 and the pilot code (see INTRODUCTION for references) predicted 0.177. The lower lifts of the panel methods are probably due to the fact that the lifting pressure is forced to zero at the side edges of the flaps, whereas the lifting pressure from the kernel function method is generally non-zero at these locations. In other words, the kernel function method treats the flap gaps as sealed, whereas, the panel methods treat the gaps as unsealed.

Neither theory agrees exceptionally well with the experimental data. This discrepancy is most likely due to viscous effects.

Figure 6.5 (a)-(d) compares PAN AIR results for solution 1 with pilot code results at spanwise stations near the edges of the flap. The pilot code modelling was identical to the PAN AIR modelling. The two codes agree very well except for some minor discrepancy just aft of the hingeline. There was, however, no significant discrepancy between PAN AIR and pilot code results at $y_0 = .4372$.

As expected, solutions 2 and 3 exhibit virtually null solutions.

REFERENCES

- 6.1 Hammond, Alexander D.; and Keffer, Barbara M.: The Effect at High Subsonic Speeds of a Flap-Type Aileron on the Chordwise Pressure Distribution Near Midsemispan of a Tapered 35° Sweptback Wing of Aspect Ratio 4 Having NACA 65A006 Airfoil Section. NACA RM L53C23, 1953.
- 6.2 Medan, Richard T.: Steady, Subsonic, Lifting Surface Theory for Wings with Swept, Partial Span, Trailing Edge Control Surfaces. NASA TN D-7251, April 1973.

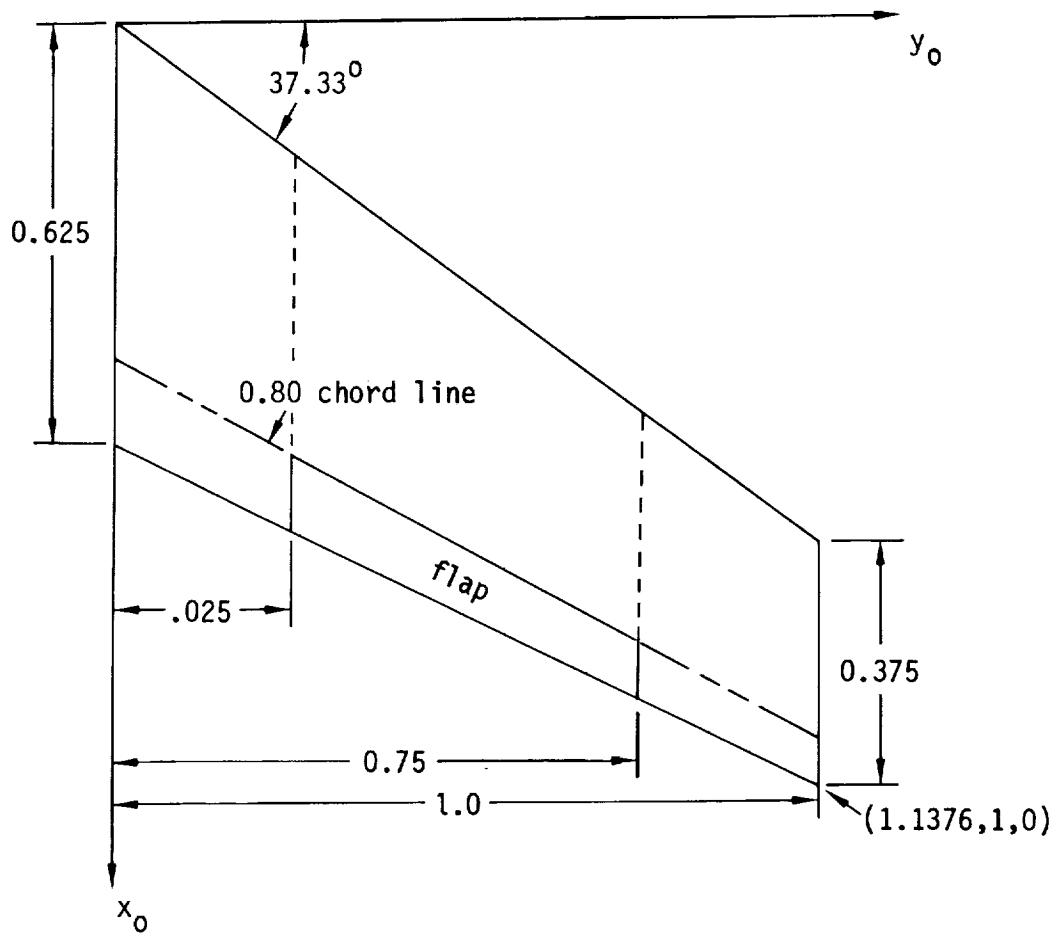

Figure 6.1 - Illustration of wing with deflected flap

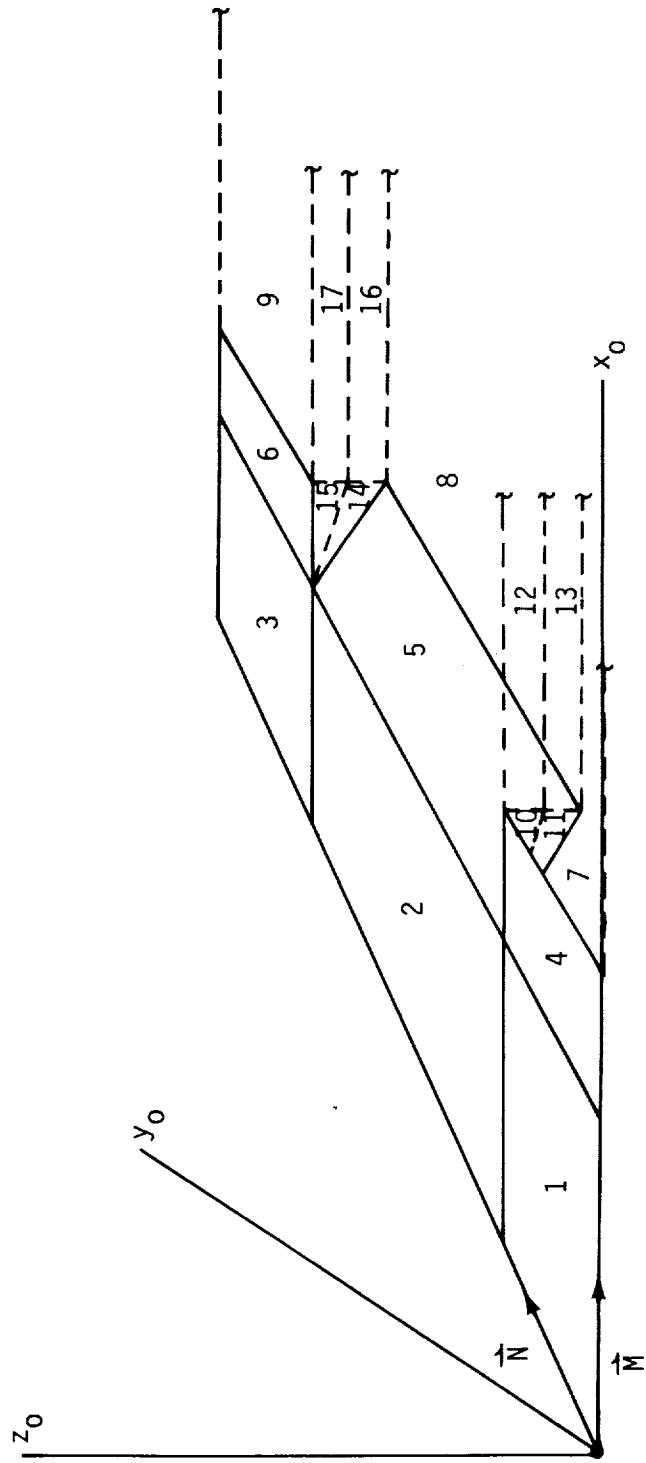

Figure 6.2 - Networks for wing with deflected flap

```

// PAN AIR CASE MANUAL CASE 6
// VALIDATION CASE, THIN WING WITH DEFLECTED FLAP, MACH=0.6
// CLASS 1 BOUNDARY CONDITIONS, EXCEPT CLASS 2 ON NETWORK A5
// SOLUTION 1 = ORIGINAL PROBLEM (EQUIV TO BOUN COND = 1, AVERAGE)
// SOLUTION 2 = SPECIFIED FLOW USED TO ELIMINATE FLAP DEFLECTION
// SOLUTION 3 = LOCAL ONSET FLOW USED TO ELIMINATE FLAP DEFLECTION
// SOLUTIONS 2 AND 3 SHOULD GIVE APPROXIMATELY NULL SOLUTIONS
// FOR ALL NETWORKS IN X-Y PLANE
// NORMAL VECTOR POINTS DOWNWARD (-Z DIRECTION)
// NETWORK EDGE 1-LEADING EDGE
// NETWORK EDGE 2-OUTBOARD EDGE
// NETWORK EDGE 3-TRAILING EDGE
// NETWORK EDGE 4-INBOARD EDGE
BEGI GLOB DATA /G1
PID=VALIDATION CASE, WING WITH DEFLECTED FLAP, M=0.6
UID=USER IDENTIFICATION
// OMIT RECORD G4, DEFAULT IS ONE PLANE OF CONFIGURATION AND FLOW SYMMETRY
MACH = 0.6 /G5
// DEFINE 3 SOLUTIONS (WITH ALPHA=0)
SID = SOLN-1, SOLN-2, SOLN-3 /G6
// TURN OFF AUTOMATIC ABUTMENT SEARCH, SINCE ALL ABUTMENTS ARE SPECIFIED
// IN THE GEOMETRIC EDGE MATCHING DATA GROUP
TOLERANCE = -.0001 /G7
SURF = UPLO, AVERAGE /G8
SELE VELOCITY COMP = VIC-LAMBDA /G9
PRES = LINE SECO /G12
CHECKOUT PRINTS = DIP 1 2 3, DQG 1 2 4 5 6 /G17
//
BEGI NETW DATA /N1
NETW = A1, 6, 4 /N2A
0.000000 0.000000 0.000000 .154500 0.000000 0.000000
.307815 0.000000 0.000000 .404500 0.000000 0.000000
.487875 0.000000 0.000000 .500000 0.000000 0.000000
.095350 .125000 0.000000 .242125 .125000 0.000000
.387774 .125000 0.000000 .479625 .125000 0.000000
.558831 .125000 0.000000 .570350 .125000 0.000000
.165146 .216500 0.000000 .306267 .216500 0.000000
.446304 .216500 0.000000 .534617 .216500 0.000000
.610771 .216500 0.000000 .621846 .216500 0.000000
.190700 .250000 0.000000 .329750 .250000 0.000000
.467734 .250000 0.000000 .554750 .250000 0.000000
.629788 .250000 0.000000 .640700 .250000 0.000000
STORE VIC MATRIX /N3
// DEFINE GLOBAL (OVERALL) DEFAULT FOR BOUNDARY CONDITION RECORD
BOUN = OVER, 1, 3 /N9

```

Figure 6.3 - Input for test case 6.

```

NETW = A2, 6, 7      /N2A
.190700 .250000 0.000000 .329750 .250000 0.000000
.467734 .250000 0.000000 .554750 .250000 0.000000
.629788 .250000 0.000000 .640700 .250000 0.000000
.216247 .283500 0.000000 .353227 .283500 0.000000
.489156 .283500 0.000000 .574877 .283500 0.000000
.648797 .283500 0.000000 .659547 .283500 0.000000
.286025 .375000 0.000000 .417350 .375000 0.000000
.547668 .375000 0.000000 .629850 .375000 0.000000
.700719 .375000 0.000000 .711025 .375000 0.000000
.381350 .500000 0.000000 .504950 .500000 0.000000
.627602 .500000 0.000000 .704950 .500000 0.000000
.771650 .500000 0.000000 .781350 .500000 0.000000
.476675 .625000 0.000000 .592550 .625000 0.000000
.707536 .625000 0.000000 .780050 .625000 0.000000
.842581 .625000 0.000000 .851675 .625000 0.000000
.546453 .716500 0.000000 .656673 .716500 0.000000
.766048 .716500 0.000000 .835023 .716500 0.000000
.894503 .716500 0.000000 .903153 .716500 0.000000
.572000 .750000 0.000000 .680150 .750000 0.000000
.787471 .750000 0.000000 .855150 .750000 0.000000
.913513 .750000 0.000000 .922000 .750000 0.000000
STORE VIC MATRIX /N3
NETW = A3, 6, 4      /N2A
.572000 .750000 0.000000 .680150 .750000 0.000000
.787471 .750000 0.000000 .855150 .750000 0.000000
.913513 .750000 0.000000 .922000 .750000 0.000000
.597540 .783500 0.000000 .703620 .783500 0.000000
.808886 .783500 0.000000 .875270 .783500 0.000000
.932515 .783500 0.000000 .940840 .783500 0.000000
.667300 .875000 0.000000 .767725 .875000 0.000000
.867380 .875000 0.000000 .930225 .875000 0.000000
.984419 .875000 0.000000 .992300 .875000 0.000000
.762600 1.000000 0.000000 .855300 1.000000 0.000000
.947289 1.000000 0.000000 1.005300 1.000000 0.000000
1.055325 1.000000 0.000000 1.062600 1.000000 0.000000
STORE VIC MATRIX /N3
NETW = A4, 6, 4      /N2A
.500000 0.000000 0.000000 .506125 0.000000 0.000000
.523875 0.000000 0.000000 .551500 0.000000 0.000000
.586375 0.000000 0.000000 .625000 0.000000 0.000000
.570350 .125000 0.000000 .576169 .125000 0.000000
.593031 .125000 0.000000 .619275 .125000 0.000000
.652406 .125000 0.000000 .689100 .125000 0.000000
.621846 .216500 0.000000 .627441 .216500 0.000000
.643654 .216500 0.000000 .668886 .216500 0.000000

```

Figure 6.3 - Continued.

```

.700741 .216500 0.000000 .736021 .216500 0.000000
.640700 .250000 0.000000 .646213 .250000 0.000000
.662188 .250000 0.000000 .687050 .250000 0.000000
.718438 .250000 0.000000 .753200 .250000 0.000000
STORE VIC MATRIX /N3
NETW = A5, 6, 7 /N2A
// A5 IS THE DEFLECTED FLAP NETWORK
.640700 .250000 0.000000 .646213 .250000 .000957
.662188 .250000 .003730 .687050 .250000 .008046
.718438 .250000 .013495 .753200 .250000 .019530
.659547 .283500 0.000000 .664978 .283500 .000943
.680715 .283500 .003675 .705207 .283500 .007927
.736127 .283500 .013294 .770372 .283500 .019239
.711025 .375000 0.000000 .716231 .375000 .000904
.731319 .375000 .003523 .754800 .375000 .007599
.784444 .375000 .012745 .817275 .375000 .018445
.781350 .500000 0.000000 .786250 .500000 .000851
.800450 .500000 .003316 .822550 .500000 .007152
.850450 .500000 .011996 .881350 .500000 .017360
.851675 .625000 0.000000 .856269 .625000 .000797
.869581 .625000 .003109 .890300 .625000 .006705
.916456 .625000 .011246 .945425 .625000 .016275
.903153 .716500 0.000000 .907522 .716500 .000759
.920185 .716500 .002957 .939893 .716500 .006378
.964773 .716500 .010697 .992328 .716500 .015481
.922000 .750000 0.000000 .926288 .750000 .000744
.938713 .750000 .002901 .958050 .750000 .006258
.982463 .750000 .010496 1.009500 .750000 .015190
STORE VIC MATRIX /N3
BOUN = 2, 3 /N9
// DEFINE SPECIFIED FLOW AND LOCAL ONSET FLOW FOR NETWORK A5
SPEC FLOW /N17A
TERM = 2 /N17B
INPUT-IMAGES = INPUT, 1ST /N17C
SOLU = SOLN-2 /N17D
POINTS = ALL $ +.17025 /N17E,F
LOCAL ONSET FLOW /N18A
TERM = VXYZ /N18B
INPUT-IMAGES = INPUT, 1ST /N18C
SOLU = SOLN-3 /N18D
POINTS = ALL $ 0., 0., +.1736 /N18E,F

```

Figure 6.3 - Continued.

```

NETW = A6, 6, 4 /N2A
.922000 .750000 0.000000 .926288 .750000 0.000000
.938713 .750000 0.000000 .958050 .750000 0.000000
.982463 .750000 0.000000 1.009500 .750000 0.000000
.940840 .783500 0.000000 .945046 .783500 0.000000
.957233 .783500 0.000000 .976200 .783500 0.000000
1.000145 .783500 0.000000 1.026665 .783500 0.000000
.992300 .875000 0.000000 .996281 .875000 0.000000
1.007819 .875000 0.000000 1.025775 .875000 0.000000
1.048444 .875000 0.000000 1.073550 .875000 0.000000
1.062600 1.000000 0.000000 1.066275 1.000000 0.000000
1.076925 1.000000 0.000000 1.093500 1.000000 0.000000
1.114425 1.000000 0.000000 1.137600 1.000000 0.000000
STORE VIC MATRIX /N3
NETW = A7, 2, 4 /N2A
// HORIZONTAL WAKE NETWORK
.625000 0.000000 0.000000 20.00000 0.000000 0.000000
.689100 .125000 0.000000 20.00000 .125000 0.000000
.736021 .216500 0.000000 20.00000 .216500 0.000000
.753200 .250000 0.000000 20.00000 .250000 0.000000
// DEFINE GLOBAL (OVERALL) DEFAULT FOR BOUNDARY CONDITION RECORD
BOUN = OVER, 1, 4
NETW = A8, 2, 7 /N2A
// HORIZONTAL WAKE NETWORK BEHIND DEFLECTED FLAP NETWORK A5
.753200 .250000 .019530 20.00000 .250000 .019530
.770372 .283500 .019239 20.00000 .283500 .019239
.817275 .375000 .018445 20.00000 .375000 .018445
.881350 .500000 .017360 20.00000 .500000 .017360
.945425 .625000 .016275 20.00000 .625000 .016275
.992328 .716500 .015481 20.00000 .716500 .015481
1.009500 .750000 .015190 20.00000 .750000 .015190
NETW = A9, 2, 4 /N2A
// HORIZONTAL WAKE NETWORK
1.009500 .750000 0.000000 20.00000 .750000 0.000000
1.026665 .783500 0.000000 20.00000 .783500 0.000000
1.073550 .875000 0.000000 20.00000 .875000 0.000000
1.137600 1.000000 0.000000 20.00000 1.000000 0.000000
NETW = A10, 2, 6 /N2A
// VERTICAL WAKE NETWORK
.753200 .250000 0.000000 .753200 .250000 0.000000
.718438 .250000 0.000000 .753200 .250000 .003090
.687050 .250000 0.000000 .753200 .250000 .005880
.662188 .250000 0.000000 .753200 .250000 .008090
.646213 .250000 0.000000 .753200 .250000 .009510
.640700 .250000 0.000000 .753200 .250000 .010000
NETW = A11, 2, 6 /N2A

```

Figure 6.3 - Continued.

```

// VERTICAL WAKE NETWORK
.640700 .250000 0.000000 .753200 .250000 .010000
.646213 .250000 .000957 .753200 .250000 .010467
.662188 .250000 .003730 .753200 .250000 .011820
.687050 .250000 .008046 .753200 .250000 .013926
.718438 .250000 .013495 .753200 .250000 .016585
.753200 .250000 .019530 .753200 .250000 .019530
NETW = A12, 2, 6 /N2A
// VERTICAL WAKE NETWORK
.753200 .250000 0.000000 20.00000  .250000 0.000000
.753200 .250000 .003090 20.00000  .250000 .003090
.753200 .250000 .005880 20.00000  .250000 .005880
.753200 .250000 .008090 20.00000  .250000 .008090
.753200 .250000 .009510 20.00000  .250000 .009510
.753200 .250000 .010000 20.00000  .250000 .010000
NETW = A13, 2, 6 /N2A
// VERTICAL WAKE NETWORK
.753200 .250000 .010000 20.00000  .250000 .010000
.753200 .250000 .010467 20.00000  .250000 .010467
.753200 .250000 .011820 20.00000  .250000 .011820
.753200 .250000 .013926 20.00000  .250000 .013926
.753200 .250000 .016585 20.00000  .250000 .016585
.753200 .250000 .019530 20.00000  .250000 .019530
NETW = A14, 2, 6 /N2A
// VERTICAL WAKE NETWORK
// NETWORK A14 COORDINATES ARE REVERSED (RELATIVE TO A15, A16 AND A17)
.922000 .750000 0.000000 1.009500 .750000 .007600
.926288 .750000 .000744 1.009500 .750000 .007972
.938713 .750000 .002901 1.009500 .750000 .009050
.958050 .750000 .006258 1.009500 .750000 .010727
.982463 .750000 .010496 1.009500 .750000 .012845
1.009500 .750000 .015190 1.009500 .750000 .015190
NETW = A15, 2, 6 /N2A
// VERTICAL WAKE NETWORK
.922000 .750000 0.000000 1.009500 .750000 .007600
.926288 .750000 0.000000 1.009500 .750000 .007228
.938713 .750000 0.000000 1.009500 .750000 .006148
.958050 .750000 0.000000 1.009500 .750000 .004469
.982463 .750000 0.000000 1.009500 .750000 .002348
1.009500 .750000 0.000000 1.009500 .750000 0.000000
NETW = A16, 2, 6
// VERTICAL WAKE NETWORK
1.009500 .750000 .015190 20.00000  .750000 .015190
1.009500 .750000 .012845 20.00000  .750000 .012845
1.009500 .750000 .010727 20.00000  .750000 .010727
1.009500 .750000 .009050 20.00000  .750000 .009050
1.009500 .750000 .007972 20.00000  .750000 .007972
1.009500 .750000 .007600 20.00000  .750000 .007600
NETW = A17, 2, 6

```

Figure 6.3 - Continued.

```

// VERTICAL WAKE NETWORK
1.009500 .750000 .007600 20.00000 .750000 .007600
1.009500 .750000 .007228 20.00000 .750000 .007228
1.009500 .750000 .006148 20.00000 .750000 .006148
1.009500 .750000 .004469 20.00000 .750000 .004469
1.009500 .750000 .002348 20.00000 .750000 .002348
1.009500 .750000 0.000000 20.00000 .750000 0.000000
//
BEGIN GEOM MATCHING DATA /GE1
ABUT = A1, 2 = A2, 4 /GE2
ABUT = A1, 3 = A4, 1 /GE2
ABUT = A1, 4 /GE2
PLAN = FIRST /GE3
ABUT = A2, 2 = A3, 4 /GE2
ABUT = A2, 3 = A5, 1 /GE2
ABUT = A3, 3 = A6, 1 /GE2
ABUT = A4, 2 = A10, 1 /GE2
ABUT = A4, 3 = A7, 1 /GE2
ABUT = A4, 4 /GE2
PLAN = FIRST /GE3
ABUT = A5, 2 = A14, 1 /GE2
ABUT = A5, 3 = A8, 1 /GE2
ABUT = A5, 4 = A11, 1 /GE2
ABUT = A6, 3 = A9, 1 /GE2
ABUT = A6, 4 = A15, 1 /GE2
ABUT = A7, 2 = A12, 4 /GE2
ABUT = A7, 4 /GE2
PLAN = FIRST /GE3
ABUT = A8, 2 = A16, 4 /GE2
ABUT = A8, 4 = A13, 2 /GE2
ABUT = A9, 4 = A17, 2 /GE2
ABUT = A10, 2 = A11, 4 /GE2
ABUT = A10, 3 = A12, 1 /GE2
ABUT = A11, 3 = A13, 1 /GE2
ABUT = A12, 2 = A13, 4 /GE2
ABUT = A14, 4 = A15, 4 /GE2
ABUT = A14, 3 = A16, 1 /GE2
ABUT = A15, 3 = A17, 1 /GE2
ABUT = A16, 2 = A17, 4 /GE2
//

```

Figure 6.3 - Continued.

```

BEGIN FLOW      /FP1
SURF FLOW = PRESSURE-CALCULATION      /SF1
// OMIT RECORD SF2, DEFAULT IS ALL NON-WAKE (I.E., A1-A6) NETWORKS
SOLUTIONS = 1 /SF3
POINTS = ALL /SF4A
PRINT = ALL /SF10A
DATA BASE=ALL /SF11A
SURF FLOW = NULL-CHECK /SF1
SOLUTIONS = 2, 3 /SF3
POINTS = CENTER /SF4A-DEFAULT
SURFACE SELECTION = UPLO /SF5
PRINTOUT /SF10A
FORCES AND MOMENTS /FM1
AXIS SYSTEMS = RCS /FM3
PRINTOUT = COLSUM, NETWORK, CONFIGURATION /FM5
DATA BASE = SAME /FM6
CASE=FORCES-AND-MOMENTS /FM7
SURFACE SELECTION=UPLO /FM12
BEGIN PRINT PLOT DATA /PP1
GEOMETRY DATA /PP2A
POINT DATA /PP3A
CONFIGURATION DATA /PP4A
NETWORKS-IMAGES =A1, INPUT, COLSUM =A2, INPUT, COLSUM +
                  =A3, INPUT, COLSUM =A4, INPUT, COLSUM +
                  =A5, INPUT, COLSUM =A6, INPUT, COLSUM /PP4D
END PROB DEF

```

Figure 6.3 - Concluded.

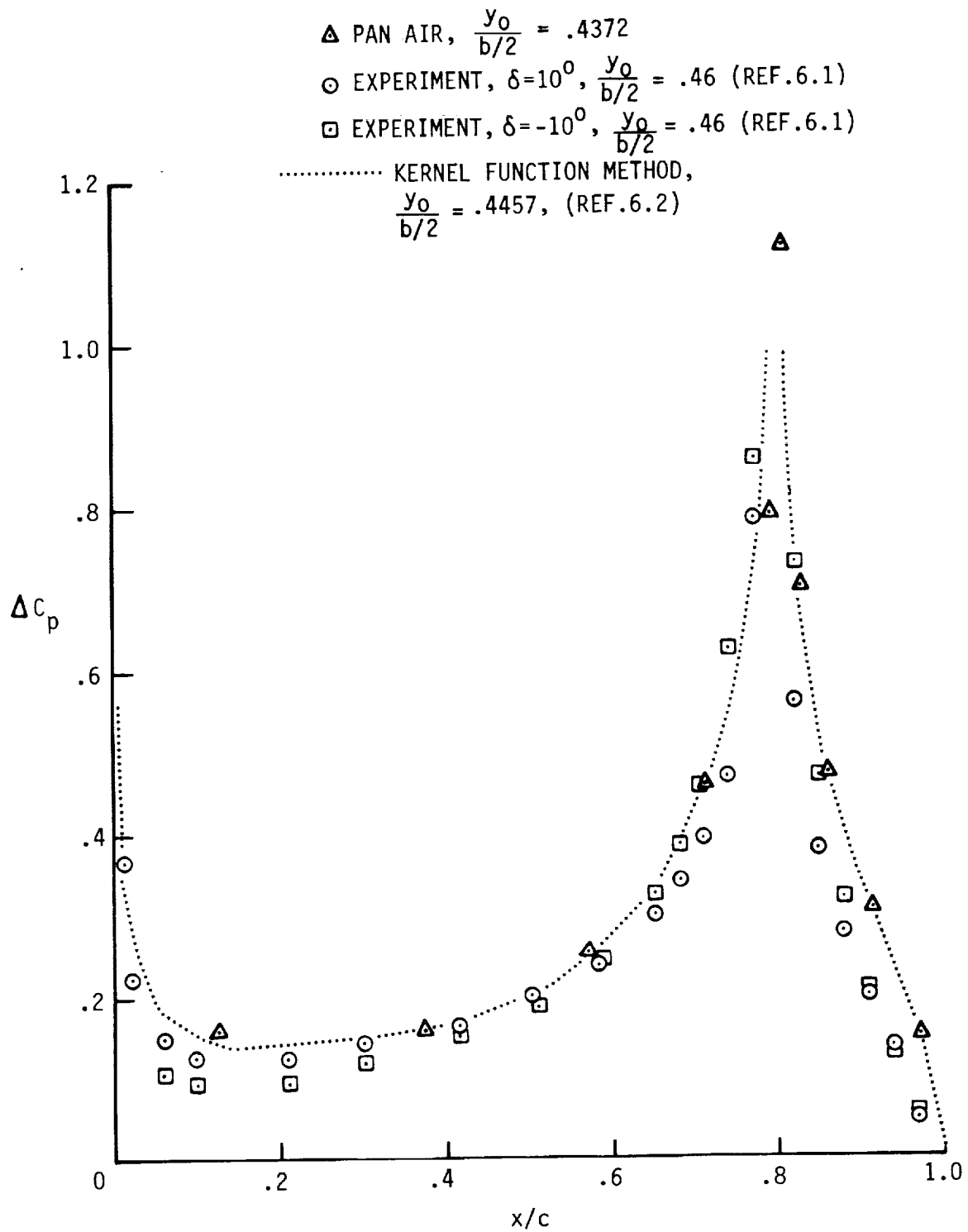
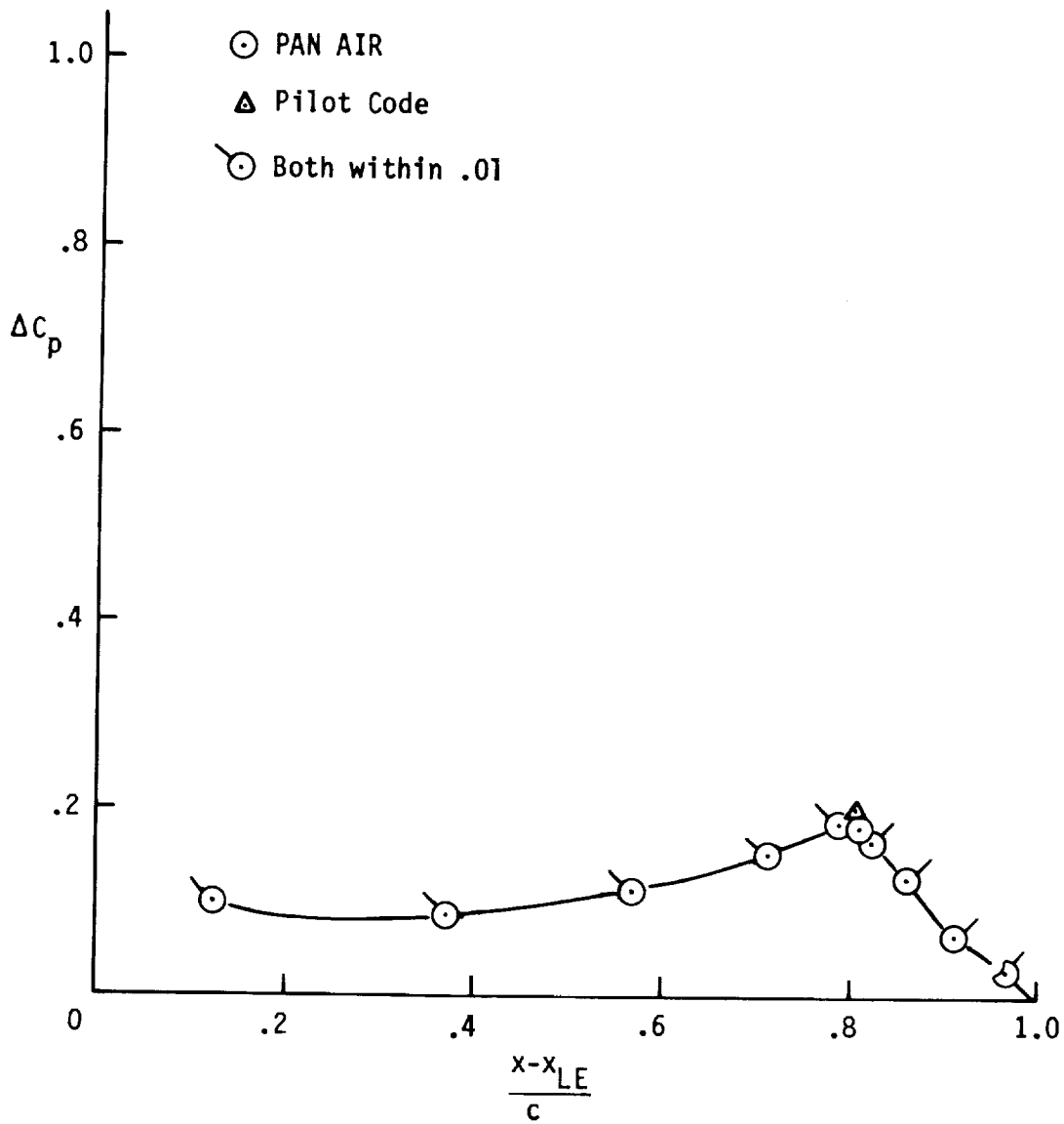
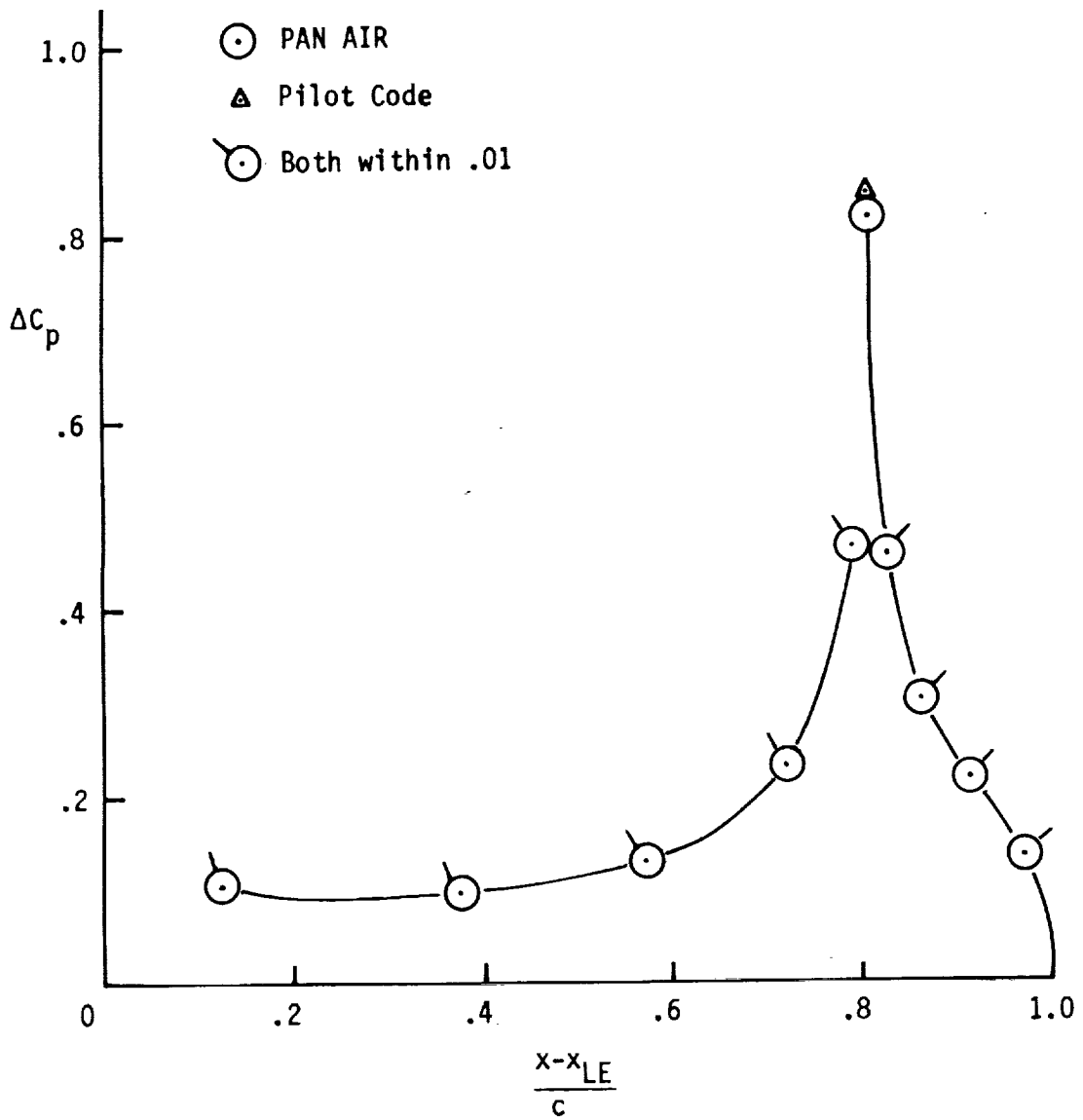

Figure 6.4 Comparison of PAN AIR pressure distribution with experiment and kernel function method for a wing with partial span flap



(a) just inboard of inboard flap edge ($\frac{y_0}{b/2} = .2332$)

Figure 6.5 PAN AIR and Pilot Code pressure coefficients on wing with deflected flap



(b) just outboard of inboard flap edge ($\frac{y_0}{b/2} = .2667$)

Figure 6.5 - Continued

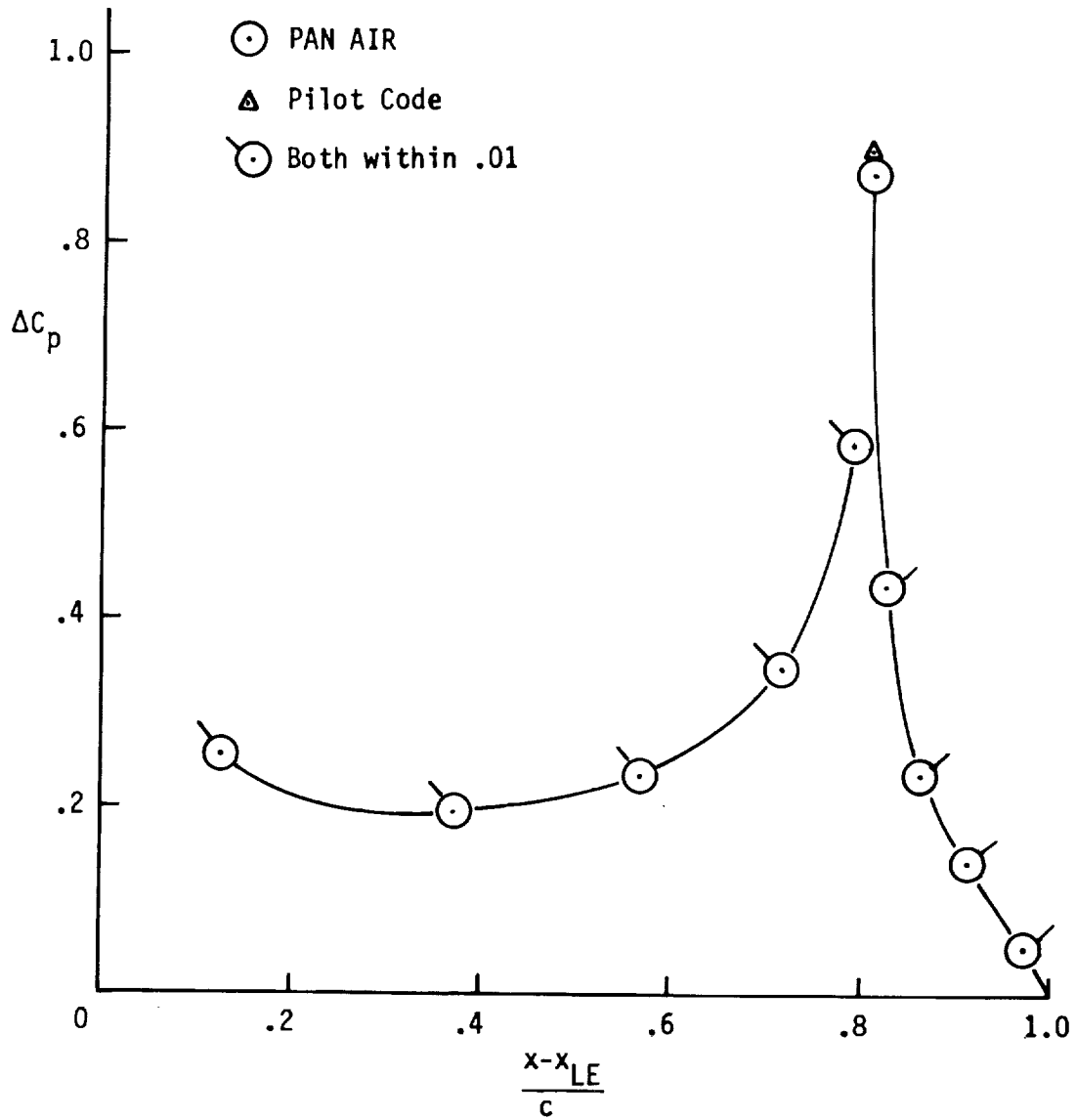

(c) just inboard of outboard flap edge ($\frac{y_0}{b/2} = .7332$)

Figure 6.5 - Continued

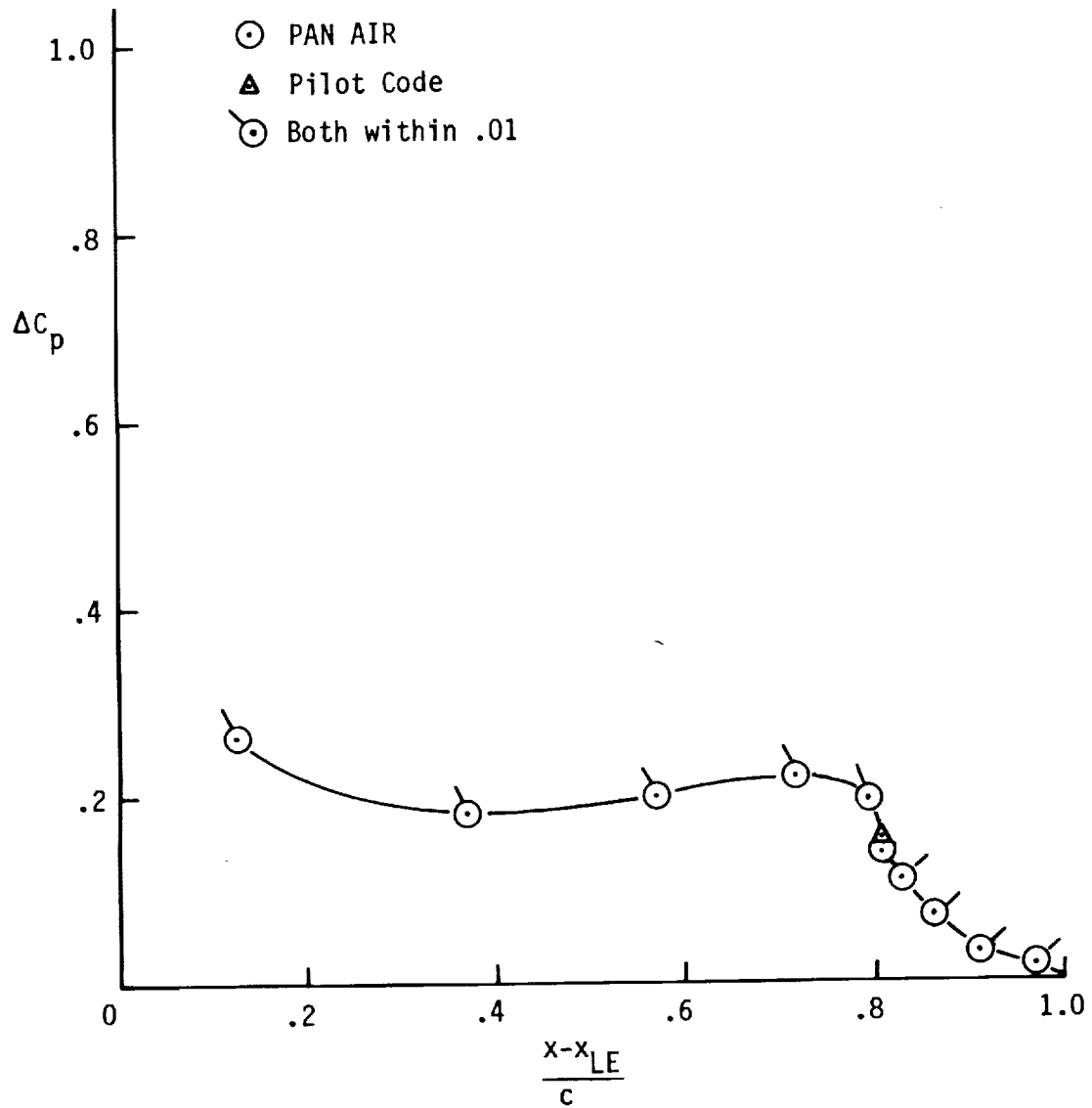

(d) just outboard of outboard flap edge ($\frac{y_0}{b/2} = .7667$)

Figure 6.5 - Concluded

7. TWO DIMENSIONAL SUBSONIC AIRFOIL DESIGN

Purpose

The purpose of these two cases (7A and 7B) is to check design boundary conditions on a thick configuration in subsonic flow. The closure condition is also checked. The two cases are complementary. Case 7A is the analysis problem (i.e., given specified (zero) normal mass flux values on a surface, determine the corresponding tangential velocity values), while case 7B is the design problem (i.e., given the tangential velocity values (from case 7A), determine the corresponding normal mass flux values). This approach thus checks the consistency of the analysis and design problems. An earlier study (reference 7.1, section 6.5.1) examined the same configuration and included the relifting of part of the configuration. There is no relifting in the present case.

Configuration, Flow, and Modeling

The configuration is the symmetric airfoil (NACA 65-010, reference 7.2), illustrated in figures 7.1 and 7.2. There are two planes of configuration symmetry (reflection in the x_0 - y_0 plane makes use of the airfoil symmetry). The aspect ratio is 12, which should result in nearly two-dimensional flow near the wing root. The airfoil is not tapered. The airfoil is divided into three networks: an analysis network from the leading edge to .2 chord, a design network from .2 to .9 chord, and an analysis network from .9 chord to the trailing edge. (Note that another network, closing the wing tip to separate the wing interior from the external flow field, should have been used. Omission of this network should not seriously affect the results since only the special case of non-lifting flow is considered.) There is a wake network, which is in the second plane of symmetry. Since the aspect ratio is not infinite there will be a spanwise variation in wing circulation. Thus, the DW1 wake network (which allows a spanwise variation in doublet strength) is used.

The flow is incompressible. There is one solution with the angles of attack and sideslip being zero. Therefore, the two planes of configuration symmetry are also taken as planes of flow symmetry.

Input

The DIP input data for case 7A is listed in figure 7.3. For the three airfoil networks, the class 1, subclass 1 boundary condition (see figure 7.4 of the User's Manual) is used, since the airfoil is impermeable and has the upper surface exposed to the external flow field. The VIC matrix is stored for the MID-WING network so that the VIC-LAMBDA method of velocity computation can later be specified in the surface flow properties and forces and moments data.

Two surface flow properties (PDP) cases are specified. The first calculates flow properties on the MID-WING network. Velocities are computed by both the BOUNDARY-CONDITION and the VIC-LAMBDA methods. The latter is generally more accurate and is used to generate the tangential velocities for the design case. The second PDP case calculates flow properties on the other two airfoil networks.

Two forces and moments (CDP) cases similar to the PDP cases are specified. The first calculates flow properties on the MID-WING network, while the second calculates flow properties on the other two airfoil networks.

The DIP input data for case 7B is listed in figure 7.4. The boundary conditions are the same as in case 7A, except that design boundary condition equations are used on the MID-WING network. Here boundary condition class 3, subclass 1 is used.

The boundary condition equations are:

$$\hat{t}_U \cdot \vec{v}_U = -\hat{t}_{t1} \cdot \vec{U}_0 + \beta_{t1} \quad (7.1)$$

$$\phi_L = 0 \quad (7.2)$$

The upper surface of the network is wetted by the external flow field.

The source singularity type is SD2 for boundary condition class 3 subclass 1. This allows the closure condition, which is appropriate for subsonic flow, to be specified. In this case the closure condition requires that the total normal mass flux emitted from the upper surface be zero for each column of panels or, equivalently, that the network leading and trailing edges be on the same mass flux streamline. Combining with the zero perturbation mass flux on the lower surface, the closure condition becomes (see section B.3.5.1 of the User's Manual)

$$\iint_{\text{edge 1}}^{\text{edge 3}} dS = - \iint_{\text{edge 1}}^{\text{edge 3}} \vec{U}_0 \cdot \hat{n} \, dS \quad (7.3)$$

Record set N14 is used to specify the closure condition, replacing the default source strength matching condition on edge 1 of the network (the leading edge). The 42 values of 1. on record N14D following the TERM = AD (record N14B) card are the values at the panel centers of AD on the left hand side of equation 7.4.1 in the User's Manual. Specification of the closure condition also requires the values of the source integral over each column of panels (i.e., BC on the right hand side of equation 7.4.1 of the User's Manual). These values are obtained from case 7A as the negative of the "volume flow" values in the CDP output (see sections B.3.5.1 and B.4.1 of the User's Manual) and appear on record N14D following the TERM=BC record. (The closure condition also requires that the update tag (record N8) be used for the network.)

In addition to the closure condition data, the known factors and terms in the boundary condition equations must be specified. In particular, the tangent vectors and β_{t1} in equation (7.1) must be specified. Record set N16 specifies the tangent vectors. The MID-POINT=1 option (record N16G) is used: the tangent vectors are unit vectors parallel to the line connecting the mid-point of edge 1 to the mid-point of edge 3 in each panel. Consequently the vectors have no y_0 component. Values of β_{t1} are specified by record set N17.* The values used in N17 are velocity magnitudes printed out in case 7A for the VIC-LAMBDA method. Since the y_0 velocity components are all small and the aspect ratio is large, this is an acceptable approximation.

Two surface flow properties (PDP) cases and two forces and moments (CDP) cases are specified. These are similar to those for the analysis case 7A.

Results and Discussion

Figure 7.5 shows the square of the tangential velocity on the airfoil, as computed in case 7A for the center control points on the inboard panel column, and compares them to the theoretical values in reference 7.2. The computed values can be seen to be in close agreement to the theoretical values.

The check on the design boundary conditions is that case 7B should show small values for the normal mass flux and that it repeat the input tangential velocity values on the MID-WING network. The normal mass flux values seen in the output from case 7B were indeed small. For example, the normal mass flux on the upper surface varied from -0.00279 to 0.00104 on the outboard panel column and from -0.00052 to 0.00042 on the inboard column. (These non-zero values are due to use of the VIC-LAMBDA method for computing the velocities. This method does not use the perturbation potential condition, equation (7.2), for the lower surface. The difference normal mass flux, which is the source strength, shows a very close agreement with the values in the analysis case 7A.) The output velocity magnitude values were also noted to be in very close agreement with the values input via record N17, with the largest difference being one digit in the fifth place.

* Equation (7.1) says that $\beta_{t1} = \hat{t} \cdot \vec{V}_U$. Since equation (7.1) is associated with the SD2 singularity type, it is applied only at the panel center control points. (The SD2 singularity type also requires an equation along edge 1, but the closure equation is used there. See figures 7.6 and 7.8 of the User's Manual.) For this reason the actual β_{t1} values are specified only at the panel center control points (record N17E). However, values need to be assigned at all control points even if the values are not used, and this is the reason that the card "POINTS = ALL \$ 1.0" appears.

REFERENCES

- 7.1 Johnson, Forrester T.: A General Panel Method for the Analysis and Design of Arbitrary Configurations in Incompressible Flows. NASA CR-3079, May 1980.
- 7.2 Abbott, I. H.; Von Doenhoff, A. E.; and Stiver, L. S. Jr.: Summary of Airfoil Data. NACA Report 824, 1945.

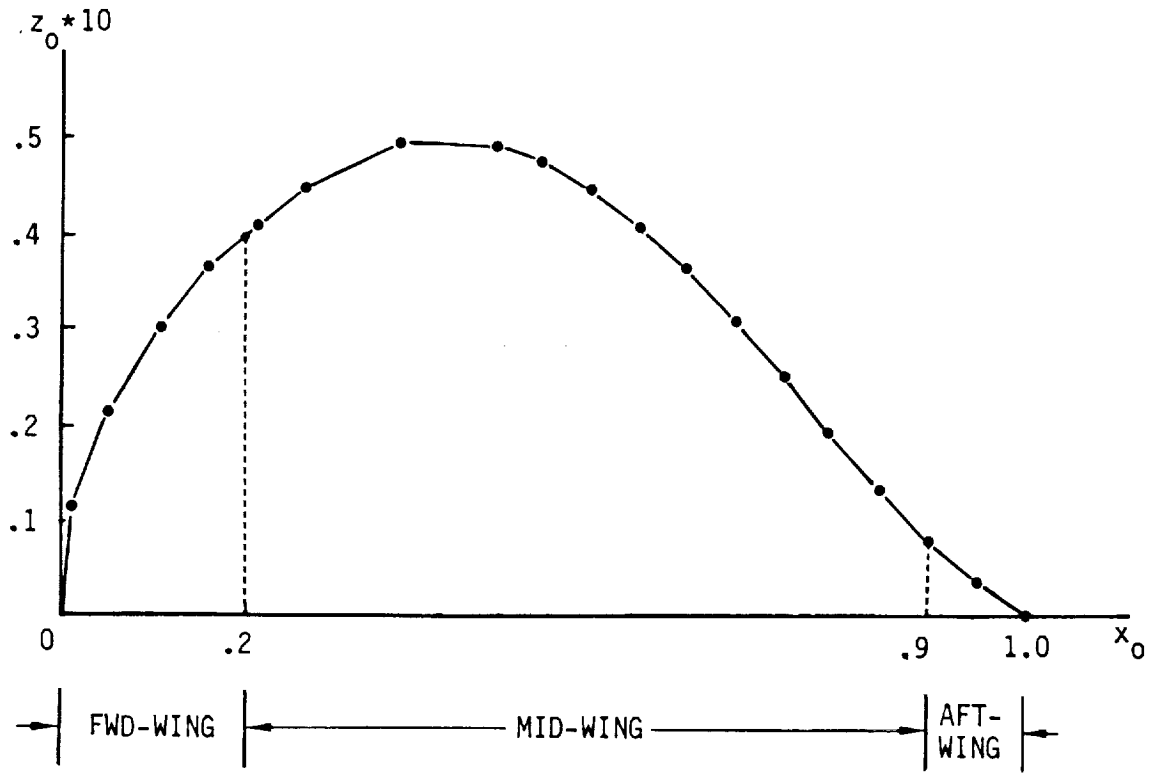

Figure 7.1 - Cross section of wing for thick wing design case

First Plane of Symmetry

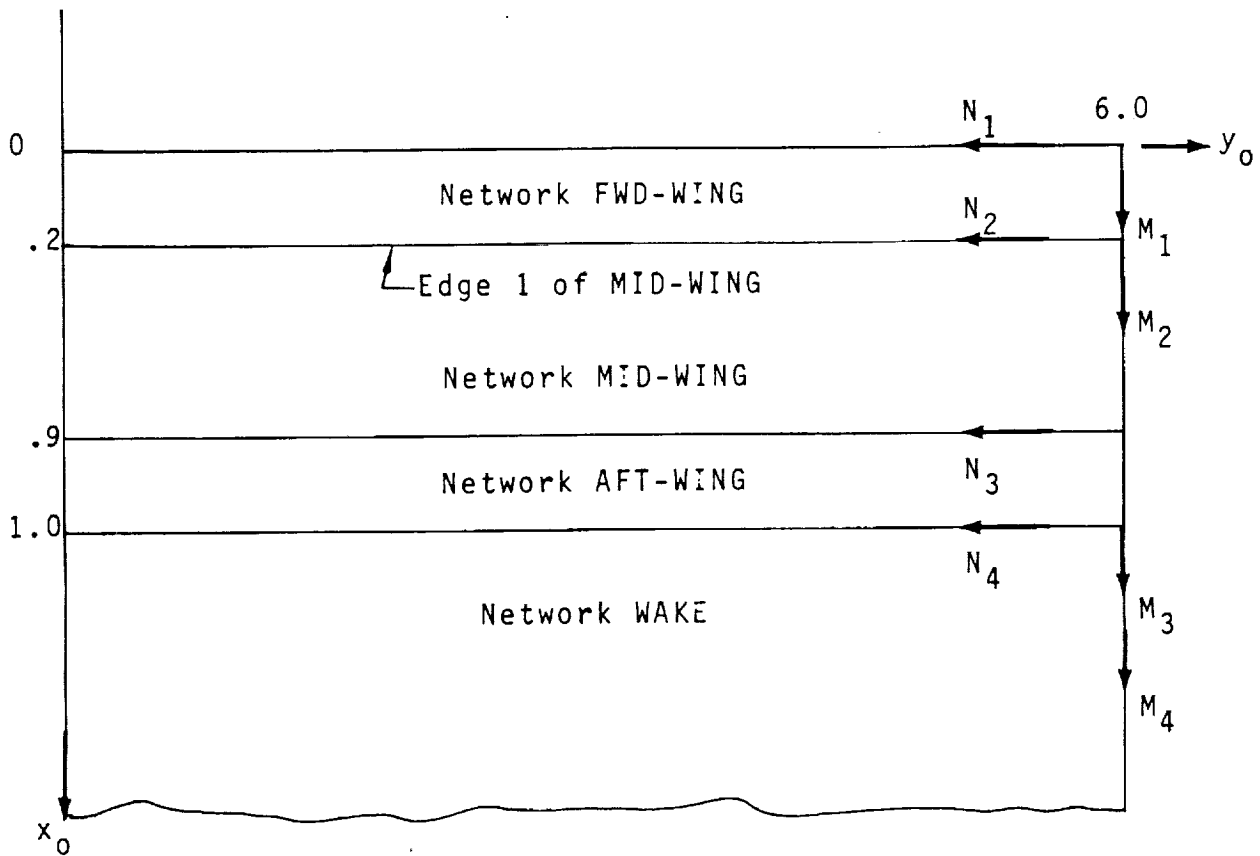

Figure 7.2 - Planform for thick wing design case

```

//
// PAN AIR CASE MANUAL CASE 7A
// SUBSONIC DESIGN PROBLEM
// THICK AIRFOIL AND WAKE, WITH TWO PLANES OF CONFIGURATION SYMMETRY
// INCOMPRESSIBLE FLOW, WITH TWO PLANES OF FLOW SYMMETRY
// AIRFOIL NACA 65-010, REF. ABBOTT AND VONDOENHOFF, PAGE 362
// ALSO REF. NASA CR-3079, FIGURE 27
// ANALYSIS CASE - GIVEN ZERO NORMAL MASS FLUX,
// SOLVE FOR THE TANGENTIAL VELOCITIES
BEGIN GLOBAL DATA /G1
PID= SUBSONIC DESIGN PROBLEM - ANALYSIS RUN
UID=USER-IDENTIFICATION
CONF = SECOND-PLANE, SYMMETRIC-FLOW /G4
MACH = .00 /G5
// DEFAULT SOLUTION DATA, ALPHA AND BETA = 0. AND UNIF = 1.
SID = SOLUTION-1
SURFACE SELECTION = UPPER /G8
PRESSURE COEFFICIENT RULES = SECOND-ORDER /G12
CHECKOUT PRINTS = DIP 1 2 3, DQG 1 2 4 5 6 7 /G17
BEGIN NETWORK DATA /N1
// START DATA ON FWD-WING NETWORK
NETWORK=FWD-WING, 10, 4
.00 6. .00000, .005 6. .00772,
.0075 6. .00932, .0125 6. .01169,
.025 6. .01574, .050 6. .02177,
.075 6. .02647, .10 6. .03040,
.15 6. .03666, .20 6. .04143,
.00 4. .00000, .005 4. .00772,
.0075 4. .00932, .0125 4. .01169,
.025 4. .01574, .050 4. .02177,
.075 4. .02647, .10 4. .03040,
.15 4. .03666, .20 4. .04143,
.00 2. .00000, .005 2. .00772,
.0075 2. .00932, .0125 2. .01169,
.025 2. .01574, .050 2. .02177,
.075 2. .02647, .10 2. .03040,
.15 2. .03666, .20 2. .04143,
.00 0. .00000, .005 0. .00772,
.0075 0. .00932, .0125 0. .01169,
.025 0. .01574, .050 0. .02177,
.075 0. .02647, .10 0. .03040,
.15 0. .03666, .20 0. .04143,
BOUNDARY CONDITION = 1, 1 /N9
// END DATA ON FWD-WING NETWORK

```

Figure 7.3 - Input for test case 7A.

```

// START DATA ON MID-WING NETWORK
NETWORK=MID-WING, 15, 4
.20 6. .04143, .25 6. .04503,
.30 6. .04760, .35 6. .04924,
.40 6. .04996, .45 6. .04963,
.50 6. .04812, .55 6. .04530,
.60 6. .04146, .65 6. .03682,
.70 6. .03156, .75 6. .02584,
.80 6. .01987, .85 6. .01385,
.90 6. .00810,
.20 4. .04143, .25 4. .04503,
.30 4. .04760, .35 4. .04924,
.40 4. .04996, .45 4. .04963,
.50 4. .04812, .55 4. .04530,
.60 4. .04146, .65 4. .03682,
.70 4. .03156, .75 4. .02584,
.80 4. .01987, .85 4. .01385,
.90 4. .00810,
.20 2. .04143, .25 2. .04503,
.30 2. .04760, .35 2. .04924,
.40 2. .04996, .45 2. .04963,
.50 2. .04812, .55 2. .04530,
.60 2. .04146, .65 2. .03682,
.70 2. .03156, .75 2. .02584,
.80 2. .01987, .85 2. .01385,
.90 2. .00810,
.20 0. .04143, .25 0. .04503,
.30 0. .04760, .35 0. .04924,
.40 0. .04996, .45 0. .04963,
.50 0. .04812, .55 0. .04530,
.60 0. .04146, .65 0. .03682,
.70 0. .03156, .75 0. .02584,
.80 0. .01987, .85 0. .01385,
.90 0. .00810,
STORE VIC MATRIX /N3
BOUNDARY CONDITION = 1, 1 /N9
// END DATA ON MID-WING NETWORK
// START DATA ON AFT-WING NETWORK
NETWORK=AFT-WING, 3, 4
.90 6. .00810, .95 6. .00306,
1.00 6. .00000,
.90 4. .00810, .95 4. .00306,
1.00 4. .00000,
.90 2. .00810, .95 2. .00306,
1.00 2. .00000,
.90 0. .00810, .95 0. .00306,
1.00 0. .00000,
BOUNDARY CONDITION = 1, 1 /N9
// END DATA ON AFT-WING NETWORK

```

Figure 7.3 - Continued.

```

// START DATA ON WAKE NETWORK
NETWORK=WAKE, 2, 4
// WAKE NETWORK IS IN THE SECOND PLANE OF SYMMETRY
1. 6. 0., 50. 6. 0.,
1. 4. 0., 50. 4. 0.,
1. 2. 0., 50. 2. 0.,
1. 0. 0., 50. 0. 0.,
BOUNDARY CONDITION = 1, 4 /N9
// END DATA ON WAKE NETWORK
BEGIN FLOW PROPERTIES DATA /FP1
SURFACE FLOW PROP=INSIDE-NETWORK /SF1
NETWORKS-IMAGES = MID-WING /SF2
POINTS = ALL /SF4A
SURFACE SELECTION = UPPER, LOWER /SF5
SELECTION OF VELOCITY COMPUTATION = BOUNDARY-CONDITION, VIC-LAMBDA /SF6
PRINTOUT = ALL /SF10A
DATA BASE = ALL /SF11A
SURFACE FLOW PROP=OUTSIDE-NETWORKS /SF1
NETWORKS-IMAGES = FWD-WING = AFT-WING /SF2
POINTS=CENTER /SF4A
PRINTOUT = ALL /SF10A
DATA BASE = ALL /SF11A
FORCES AND MOMENTS /FM1
AXIS = RCS /FM3
PRINTOUT = COLSUM, NETWORKS, CONFIGURATION /FM5
DATA BASE = COLSUM, NETWORKS, CONFIGURATION /FM6
CASE = FM-INSIDE-NETWORK /FM7
NETWORKS-IMAGES = MID-WING, INPUT /FM8
SELECTION OF VELOCITY COMPUTATION = BOUNDARY-CONDITION, VIC-LAMBDA /FM13
ACCUMULATE = VIC-LAMBDA /FM21
CASE = FM-OUTSIDE-NETWORKS /FM7
NETWORKS-IMAGES = FWD-WING, INPUT = AFT-WING, INPUT /FM8
ACCUMULATE /FM21
/// PRINT-PLOT DATA GROUP
BEGIN PRINT PLOT DATA /PP1
GEOMETRY DATA /PP2A
POINT DATA /PP3A
CONFIGURATION DATA /PP4A
END PROBLEM DEFINITION

```

Figure 7.3 - Concluded.

```

//
// PAN AIR CASE MANUAL CASE 7B
// SUBSONIC DESIGN PROBLEM
// THICK AIRFOIL AND WAKE, WITH TWO PLANES OF CONFIGURATION SYMMETRY
// INCOMPRESSIBLE FLOW, WITH TWO PLANES OF FLOW SYMMETRY
// AIRFOIL NACA 65-010, REF. ABBOTT AND VONDOENHOFF, PAGE 362
// ALSO REF. NASA CR-3079, FIGURE 27
// DESIGN CASE - GIVEN TANGENTIAL VELOCITIES,
// SOLVE FOR THE NORMAL MASS FLUX
BEGIN GLOBAL DATA /G1
PID= SUBSONIC DESIGN PROBLEM - DESIGN RUN
UID=USER-IDENTIFICATION
CONF = SECOND-PLANE, SYMMETRIC-FLOW /G4
MACH = .00 /G5
// DEFAULT SOLUTION DATA, ALPHA AND BETA = 0. AND UNIF = 1.
SID = SOLUTION-1
SURFACE SELECTION = UPPER /G8
PRESSURE COEFFICIENT RULES = SECOND-ORDER /G12
CHECKOUT PRINTS = DIP 1 2 3, DQG 1 2 4 5 6 7 /G17
BEGIN NETWORK DATA /N1
// START DATA ON FWD-WING NETWORK
NETWORK=FWD-WING, 10, 4
.00 6. .00000, .005 6. .00772,
.0075 6. .00932, .0125 6. .01169,
.025 6. .01574, .050 6. .02177,
.075 6. .02647, .10 6. .03040,
.15 6. .03666, .20 6. .04143,
.00 4. .00000, .005 4. .00772,
.0075 4. .00932, .0125 4. .01169,
.025 4. .01574, .050 4. .02177,
.075 4. .02647, .10 4. .03040,
.15 4. .03666, .20 4. .04143,
.00 2. .00000, .005 2. .00772,
.0075 2. .00932, .0125 2. .01169,
.025 2. .01574, .050 2. .02177,
.075 2. .02647, .10 2. .03040,
.15 2. .03666, .20 2. .04143,
.00 0. .00000, .005 0. .00772,
.0075 0. .00932, .0125 0. .01169,
.025 0. .01574, .050 0. .02177,
.075 0. .02647, .10 0. .03040,
.15 0. .03666, .20 0. .04143,
UPDATE TAG = 3 /N8
BOUNDARY CONDITION = 1, 1 /N9
// END DATA ON FWD-WING NETWORK

```

Figure 7.4 - Input for test case 7B.

```

// START DATA ON MID-WING NETWORK
NETWORK=MID-WING, 15, 4
.20 6. .04143, .25 6. .04503,
.30 6. .04760, .35 6. .04924,
.40 6. .04996, .45 6. .04963,
.50 6. .04812, .55 6. .04530,
.60 6. .04146, .65 6. .03682,
.70 6. .03156, .75 6. .02584,
.80 6. .01987, .85 6. .01385,
.90 6. .00810,
.20 4. .04143, .25 4. .04503,
.30 4. .04760, .35 4. .04924,
.40 4. .04996, .45 4. .04963,
.50 4. .04812, .55 4. .04530,
.60 4. .04146, .65 4. .03682,
.70 4. .03156, .75 4. .02584,
.80 4. .01987, .85 4. .01385,
.90 4. .00810,
.20 2. .04143, .25 2. .04503,
.30 2. .04760, .35 2. .04924,
.40 2. .04996, .45 2. .04963,
.50 2. .04812, .55 2. .04530,
.60 2. .04146, .65 2. .03682,
.70 2. .03156, .75 2. .02584,
.80 2. .01987, .85 2. .01385,
.90 2. .00810,
.20 0. .04143, .25 0. .04503,
.30 0. .04760, .35 0. .04924,
.40 0. .04996, .45 0. .04963,
.50 0. .04812, .55 0. .04530,
.60 0. .04146, .65 0. .03682,
.70 0. .03156, .75 0. .02584,
.80 0. .01987, .85 0. .01385,
.90 0. .00810,
STORE VIC MATRIX /N3
UPDATE TAG /N8 - REQUIRED FOR CLOSURE CONDITION
BOUNDARY CONDITION = 3, 1 /N9
CLOSURE EDGE CONDITION = SNE = 1 /N14A
TERM = AD /N14B
1. 1. 1. 1. 1. 1. 1. 1. 1. 1. 1. 1. 1. 1.,
1. 1. 1. 1. 1. 1. 1. 1. 1. 1. 1. 1. 1. 1.,
1. 1. 1. 1. 1. 1. 1. 1. 1. 1. 1. 1. 1. 1. /N14D
TERM = BC /N14B
-0.06666 -0.06666 -0.06666 /N14D
TANGENT VECTORS FOR DESIGN /N16A
TERM = TU1, TT1 /N16B
POINTS = ALL /N16E
MID-POINT = 1 /N16G

```

Figure 7.4 - Continued.

```

SPECIFIED FLOW /N17A
// USE VMAG VALUES COMPUTED BY THE VIC-LAMBDA METHOD
// FROM CASE 7A
// TANGENTIAL VELOCITY BOUNDARY CONDITIONS ARE APPLIED ONLY AT PANEL
// CENTER CONTROL POINTS
TERM = 1 /N17B
INPUT-IMAGES = INPUT, 1ST, 2ND, 3RD /N17C
POINTS = ALL $ 1.0 /N17E,F
POINTS = CENTER /N17E
1.11265 1.11949 1.12381 1.12801 1.13084 1.12963 1.11989 /U-1A
1.10274 1.08318 1.06207 1.03925 1.01499 .98909 .96298 /U-1B
1.11562 1.12171 1.12604 1.13023 1.13306 1.13186 1.12213 /U-2A
1.10497 1.08541 1.06429 1.04143 1.01711 .99104 .96526 /U-2B
1.11575 1.12191 1.12624 1.13042 1.13325 1.13205 1.12230 /U-3A
1.10515 1.08557 1.06444 1.04158 1.01724 .99117 .96534 /U-3B
// END DATA ON MID-WING NETWORK
// START DATA ON AFT-WING NETWORK
NETWORK=AFT-WING, 3, 4
.90 6. .00810, .95 6. .00306,
1.00 6. .00000,
.90 4. .00810, .95 4. .00306,
1.00 4. .00000,
.90 2. .00810, .95 2. .00306,
1.00 2. .00000,
.90 0. .00810, .95 0. .00306,
1.00 0. .00000,
UPDATE TAG = 1 /N8
BOUNDARY CONDITION = 1, 1 /N9
// END DATA ON AFT-WING NETWORK
// START DATA ON WAKE NETWORK
NETWORK=WAKE, 2, 4
// WAKE NETWORK IS IN THE SECOND PLANE OF SYMMETRY
1. 6. 0., 50. 6. 0.,
1. 4. 0., 50. 4. 0.,
1. 2. 0., 50. 2. 0.,
1. 0. 0., 50. 0. 0.,
BOUNDARY CONDITION = 1, 4 /N9
// END DATA ON WAKE NETWORK
BEGIN FLOW PROPERTIES DATA /FP1
SURFACE FLOW PROP=INSIDE-NETWORK /SF1
NETWORKS-IMAGES = MID-WING /SF2
POINTS = ALL /SF4A
SURFACE SELECTION = UPPER, LOWER /SF5
SELECTION OF VELOCITY COMPUTATION = VIC-LAMBDA /SF6
PRINTOUT = ALL /SF10A
DATA BASE = ALL /SF11A

```

Figure 7.4 - Continued.

```
SURFACE FLOW PROP=OUTSIDE-NETWORKS /SF1
NETWORKS-IMAGES = FWD-WING = AFT-WING /SF2
POINTS=CENTER /SF4A
PRINTOUT = ALL /SF10A
DATA BASE = ALL /SF11A
FORCES AND MOMENTS /FM1
AXIS = RCS /FM3
PRINTOUT = COLSUM, NETWORKS, CONFIGURATION /FM5
DATA BASE = COLSUM, NETWORKS, CONFIGURATION /FM6
CASE = FM-INSIDE-NETWORK /FM7
NETWORKS-IMAGES = MID-WING, INPUT /FM8
SELECTION OF VELOCITY COMPUTATION = VIC-LAMBDA /FM13
ACCUMULATE /FM21
CASE = FM-OUTSIDE-NETWORKS /FM7
NETWORKS-IMAGES = FWD-WING, INPUT = AFT-WING, INPUT /FM8
ACCUMULATE /FM21
/// .PRINT-PLOT DATA GROUP
BEGIN PRINT PLOT DATA /PP1
GEOMETRY DATA /PP2A
POINT DATA /PP3A
CONFIGURATION DATA /PP4A
END PROBLEM DEFINITION
```

Figure 7.4 - Concluded.

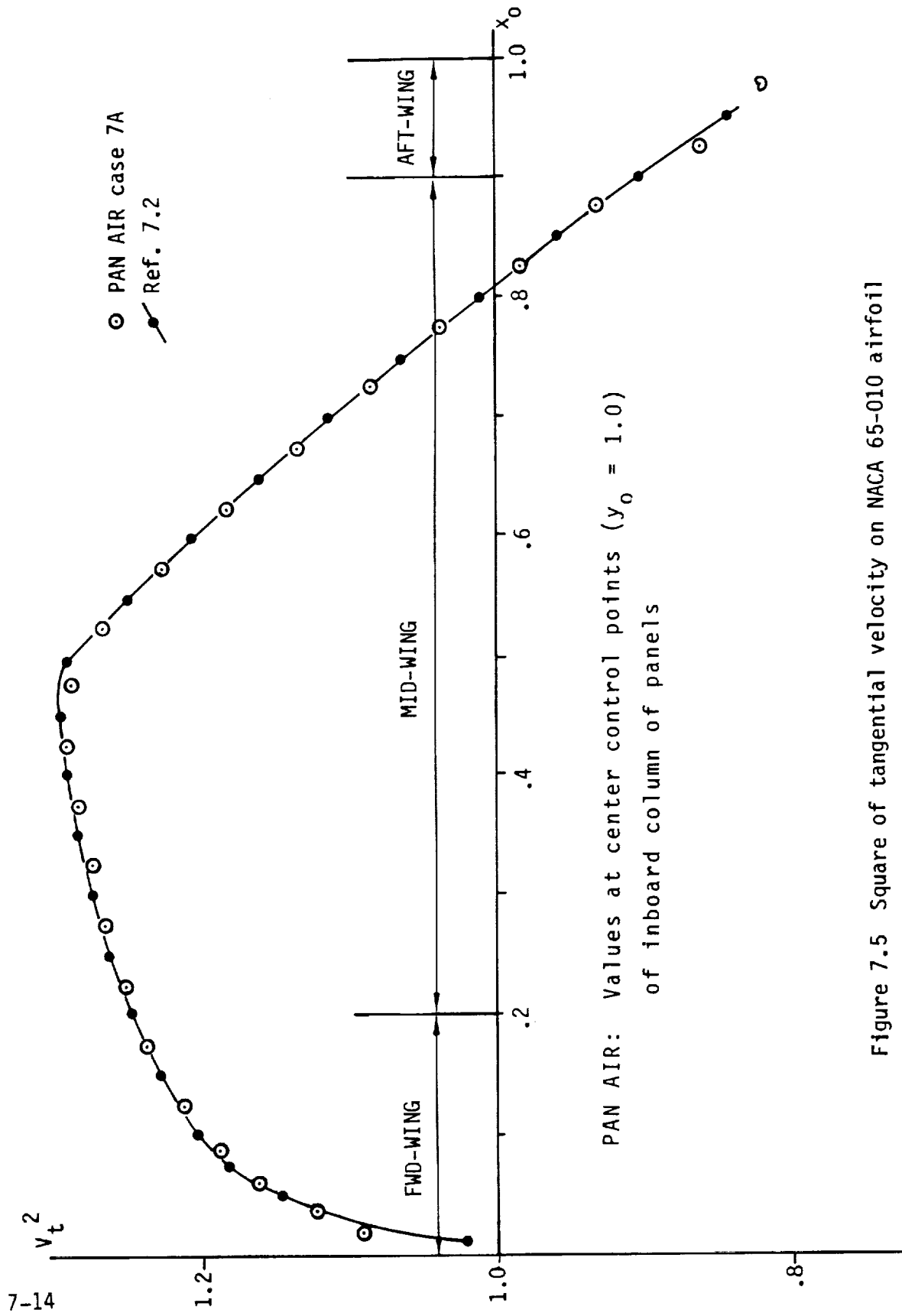

Figure 7.5 Square of tangential velocity on NACA 65-010 airfoil

8. THIN WING DESIGN

Purpose

The purpose of these two cases (8A and 8B) is to check design boundary conditions in supersonic flow on a thin configuration with a supersonic leading edge. The two cases are complementary analysis-design problems. Case 8A is the analysis problem: given specified normal mass flux values for camber and thickness representations, determine the corresponding tangential velocity values. Case 8B is the design problem: given the tangential velocity values (from case 8A), determine the corresponding normal mass flux values. This approach checks the consistency of the analysis and design problems. There is, however, no design as such, i.e., the position of the original surface is not changed.

Configuration, Flow, and Modeling

The geometry and paneling of the wing is illustrated in figure 8.1. There is one plane of configuration symmetry. The wing has an aspect ratio of 1.9 and a taper ratio of .10. The chordwise paneling is defined by a set of lines radiating from the point $(1.0, \tan(60^\circ)) \cong (1.0, 0.57735)$, which is outside the planform.

The wing is modelled with singularities placed in the x_0 - y_0 plane. Camber and thickness are simulated through specified flows to represent a parabolic top surface and a flat bottom surface, the latter lying in the x_0 - y_0 plane. The parabolic top surface is defined by

$$z_0 = .008*(x_0 - \tan(60^\circ)*y_0)*(1 - x_0)$$

Since the intersection of the above parabolic surface with the $z_0 = 0$ plane defines the leading and trailing edges, it is apparent that the wing leading edge has a 60° sweep angle (which would be sonic if the Mach number were 2.0) and the trailing edge is unswept and is given by $x_0 = 1$.

The flow Mach number is 2.2. One solution is specified with ALPHA = .573. Also, CALPHA = .573, so the compressibility axis is in the direction of the uniform onset flow. The plane of configuration symmetry is also a plane of flow symmetry.

Input

The DIP input data for case 8A is given in figure 8.2. For the wing, a class 2 subclass 5 boundary condition (see figure 7.5 of the User's Manual) is used to simulate both camber and thickness. As is shown in figure 7.5 of the User's Manual, this boundary condition requires that β_{n1} and β_{n2} be defined. According to thin airfoil theory (e.g., section B.3.2 of the User's Manual) the appropriate values of β_{n1} are to be obtained from the equation

$$\beta_{n1} = U_0 * (\partial z_t / \partial x_0)$$

where z_t is the airfoil thickness. Note that $U_0 = 1$ in this problem, so

$$\beta_{n1} = .008 * (1 - 2 * x_0 + \tan(60^\circ) * y_0)$$

Also, according to thin airfoil theory, β_{n2} should be calculated from

$$\beta_{n2} = U_0 * (\partial z_c / \partial x_0)$$

where z_c represents the mean camber surface. For this particular problem, the above equation gives

$$\beta_{n2} = .004 * (1 - 2 * x_0 + \tan(60^\circ) * y_0)$$

Note that, since the bottom surface is in the $z_0 = 0$ plane, the specified flow for camber is one-half that for thickness (i.e., $z_c = z_t/2$). Both types of specified flow terms are input at panel center control points. Values of β_{n1} (i.e., the numerical values following TERM = 1) and values of β_{n2} (i.e., the numerical values following TERM = 2) are input *.

*The first (TERM = 1) equation of the class 2 subclass 5 boundary condition is associated with the SA singularity type. Thus the β_{n1} values are used only at panel center control points (see figure 7.8 of the User's Manual). The second (TERM = 2) equation is associated with the DA singularity type. Thus the β_{n2} values are required at center, edge and additional (network corner) control points. However, these values (which are not zero) are not shown in figure 8.2. This is an error, but, since the error occurs on the COSMIC tape for Version 1.0, it is not corrected here.

To obtain more accuracy than the boundary-condition method yields, the VIC matrix is stored and used in all velocity computations. One surface flow properties (PDP) case and one forces and moments (CDP) case are specified.

The DIP input data for case 8B is given in figure 8.3. The data is similar to those of case 8A, except for the wing network boundary condition equations. These would normally be specified as class 3, subclass 5 boundary conditions (see figure 7.6 of the User's Manual). However, the boundary condition class 3 subclass 5 can not be used, because the closure condition and the associated SD2 network type is not allowed since the downstream edge is supersonic and thus can have no upstream influence. SA and DA (or the DFW) singularity types must be used instead. In particular, they are invoked by specifying class 4 boundary conditions (figure 7.7 of the User's Manual) in record N9 and by using record N11 to specify the singularity types. The boundary conditions specified by record N9 are the following (see Figure 7.6 and Section B.3.3.5 of the User's Manual):

$$\vec{t}_A \cdot \vec{v}_A = -\vec{t}_t \cdot \vec{U}_0 + \beta_{t1} \quad (8.1)$$

and

$$\vec{t}_D \cdot \vec{\nabla} \mu = \beta_{t2} \quad (8.2)$$

Note the footnote in figure 7.7 of the User's Manual, which states that β terms may be added to the right hand sides of all class 4 boundary conditions. All three of the tangent vectors in the above equations are defined by record set N16 to be unit vectors in the x_0 direction (since the vectors must be in the panels and since the y_0 components are ignored in applying the design equations). Record set N17 is used to specify β_{t1} and β_{t2} , which are the tangential velocities on the average and difference surfaces. The numerical values of β_{t1} were obtained from the VX-AVERAGE values in the output for case 8A and the numerical values of β_{t2} were obtained from the $\partial \mu_m / \partial x_0$ (labelled GMUX) values (since the left-hand side of equation (8.2) is GMUX). Note that β_{t2} is specified at CENTER, EDGE, and ADDITIONAL control points*.

* Since the singularity types are SA and DA (or DFW), both boundary condition equations are required at panel center control points. Only one equation is required at edge and additional control points. Equation (8.2) will always be selected in preference to equation (8.1). (The question of which equation PAN AIR selects is determined by the "boundary condition hierarchy" described in section H.2.5 and figure H.6 of the Theory Document.) Thus the β_{t2} values are specified for center, edge and additional control points. The β_{t1} values are specified for center control points only. (Note, however, that values need to be assigned at all control points even if the values are not used, and this is the reason the card "POINTS = ALL \$ 0." appears in the input data.)

Results and Discussion

Figure 8.4 gives the tangential perturbation velocity components that were computed in case 8A. Both x_0 and y_0 components are shown. The values are plotted against the x_0 coordinate at the mid-span chord on the wing. The x_0 tangential velocity components of case 8A were used in the data, as the specified flows β_{t1} and β_{t2} , in case 8B.

The check on the design boundary conditions is that case 8B showed the same surface flow properties as the analysis case 8A. This consisted of repetition of all three velocity (and mass flux) components. For the x_0 components, the design case is only repeating the basic input data, the specified flows, of equations (8.1) and (8.2). For the z_0 components, the design case gives the same (to printout accuracy) normal mass flux values that were originally input in the analysis case. For the y_0 components, the design case repeated the velocity component values that were computed in the analysis case and are shown in figure 8.4. The y_0 velocity components were ignored in using the design boundary conditions, equations (8.1) and (8.2), for the tangential velocities. The original reason for this was that the y_0 components were fairly small relative to the free stream velocity value. It is surprising that the design boundary conditions were able to repeat the y_0 velocity components. However, the x_0 and y_0 velocity components are related through the condition of irrotational flow, so that specification of the x_0 component implicitly includes the y_0 component. Since the design case 8B is able to repeat the solution for the velocity potential that was obtained in the analysis case 8A, the design case gives the same y_0 and z_0 flow components as the analysis case.

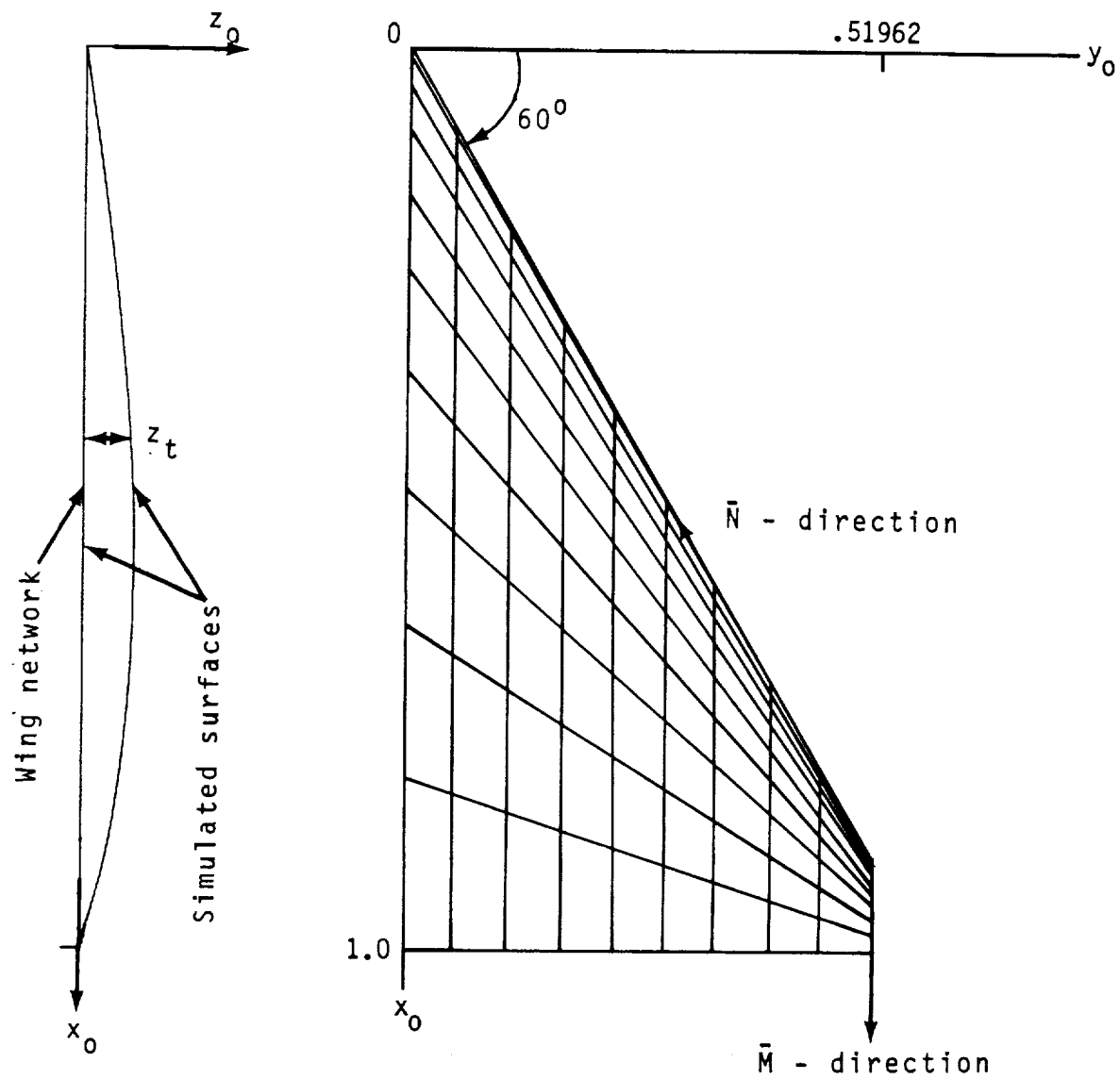

Figure 8.1 - Geometry and paneling of wing in thin wing design case

```

//
// PAN AIR CASE MANUAL CASE 8A
// SUPERSONIC DESIGN PROBLEM
// CONFIGURATION HAS A PURELY SUPERSONIC LEADING EDGE
// THIN DELTA WING AND WAKE, WITH ONE PLANE OF CONFIGURATION SYMMETRY
// SUPERSONIC FLOW, MACH = 2.2, WITH ONE PLANE OF FLOW SYMMETRY
// ANALYSIS CASE - GIVEN THICKNESS AND CAMBER REPRESENTATIONS,
// SOLVE FOR THE TANGENTIAL VELOCITIES
// START GLOBAL DATA GROUP
BEGIN GLOBAL DATA /G1
PID= SUPERSONIC DESIGN PROBLEM - ANALYSIS RUN
UID= USER IDENTIFICATION
// DEFAULT RECORD G4 -
// ONE PLANE OF CONFIGURATION SYMMETRY - NORMAL VECTOR IS +Y-AXIS
MACH=2.2 CALPHA=.573 /G5
// USE DEFAULTS FOR ALL SOLUTION DATA EXCEPT ALPHA AND SOLUTION-ID
ALPHA=.573 /G6-1
SID = SOLUTION-1 /G6-2
// USE VIC-LAMBDA METHOD FOR VELOCITY COMPUTATIONS
SELECTION OF VELOCITY COMPUTATION=VIC-LAMBDA /G9
PRESSURE COEFFICIENT RULES = ISENTROPIC, SECOND-ORDER /G12
CHECKOUT PRINTS=ALL /G17
// START NETWORK DATA GROUP
BEGIN NETWORK DATA /N1
// START DATA FOR WING NETWORK
// NETWORK IN XY PLANE - NORMAL VECTOR POINTS UPWARD (+Z-AXIS)
// NETWORK EDGE 1 = LEADING EDGE
// NETWORK EDGE 2 = INBOARD EDGE (IN PLANE OF SYMMETRY)
// NETWORK EDGE 3 = TRAILING EDGE
// NETWORK EDGE 4 = OUTBOARD EDGE
NETWORK=WING,11,10 /N2A
.90000 .51962 0.00000 .90100 .51962 0.00000
.90400 .51962 0.00000 .90900 .51962 0.00000
.91600 .51962 0.00000 .92500 .51962 0.00000
.93600 .51962 0.00000 .94900 .51962 0.00000
.96400 .51962 0.00000 .98100 .51962 0.00000
1.00000 .51962 0.00000
.80000 .46188 0.00000 .80200 .46188 0.00000
.80800 .46188 0.00000 .81800 .46188 0.00000
.83200 .46188 0.00000 .85000 .46188 0.00000
.87200 .46188 0.00000 .89800 .46188 0.00000
.92800 .46188 0.00000 .96200 .46188 0.00000
1.00000 .46188 0.00000
.70000 .40415 0.00000 .70300 .40415 0.00000
.71200 .40415 0.00000 .72700 .40415 0.00000
.74800 .40415 0.00000 .77500 .40415 0.00000
.80800 .40415 0.00000 .84700 .40415 0.00000
.89200 .40415 0.00000 .94300 .40415 0.00000
1.00000 .40415 0.00000

```

Figure 8.2 - Input for test case 8A.

.60000	.34641	0.00000	.60400	.34641	0.00000
.61600	.34641	0.00000	.63600	.34641	0.00000
.66400	.34641	0.00000	.70000	.34641	0.00000
.74400	.34641	0.00000	.79600	.34641	0.00000
.85600	.34641	0.00000	.92400	.34641	0.00000
1.00000	.34641	0.00000			
.50000	.28868	0.00000	.50500	.28868	0.00000
.52000	.28868	0.00000	.54500	.28868	0.00000
.58000	.28868	0.00000	.62500	.28868	0.00000
.68000	.28868	0.00000	.74500	.28868	0.00000
.82000	.28868	0.00000	.90500	.28868	0.00000
1.00000	.28868	0.00000			
.40000	.23094	0.00000	.40600	.23094	0.00000
.42400	.23094	0.00000	.45400	.23094	0.00000
.49600	.23094	0.00000	.55000	.23094	0.00000
.61600	.23094	0.00000	.69400	.23094	0.00000
.78400	.23094	0.00000	.88600	.23094	0.00000
1.00000	.23094	0.00000			
.30000	.17321	0.00000	.30700	.17321	0.00000
.32800	.17321	0.00000	.36300	.17321	0.00000
.41200	.17321	0.00000	.47500	.17321	0.00000
.55200	.17321	0.00000	.64300	.17321	0.00000
.74800	.17321	0.00000	.86700	.17321	0.00000
1.00000	.17321	0.00000			
.20000	.11547	0.00000	.20800	.11547	0.00000
.23200	.11547	0.00000	.27200	.11547	0.00000
.32800	.11547	0.00000	.40000	.11547	0.00000
.48800	.11547	0.00000	.59200	.11547	0.00000
.71200	.11547	0.00000	.84800	.11547	0.00000
1.00000	.11547	0.00000			
.10000	.05774	0.00000	.10900	.05774	0.00000
.13600	.05774	0.00000	.18100	.05774	0.00000
.24400	.05774	0.00000	.32500	.05774	0.00000
.42400	.05774	0.00000	.54100	.05774	0.00000
.67600	.05774	0.00000	.82900	.05774	0.00000
1.00000	.05774	0.00000			
0.00000	0.00000	0.00000	.01000	0.00000	0.00000
.04000	0.00000	0.00000	.09000	0.00000	0.00000
.16000	0.00000	0.00000	.25000	0.00000	0.00000
.36000	0.00000	0.00000	.49000	0.00000	0.00000
.64000	0.00000	0.00000	.81000	0.00000	0.00000
1.00000	0.00000	0.00000			

STORE VIC MATRIX /N3
BOUNDARY CONDITION=2,5 /N9

Figure 8.2 - Continued.

```

SPECIFIED FLOW /N17A
// THICKNESS AND CAMBER REPRESENTATIONS FOR PARABOLIC UPPER SURFACE
// AND FLAT LOWER SURFACE / BETA-N-1 = 2.*BETA-N-2
TERM=1 /N17B
// THICKNESS REPRESENTATION
INPUT-IMAGE = INPUT, 1ST /N17C
POINTS=ALL $ 0. /N17E,F
POINTS=CENTER /N17E
.0012 .0011 .0010 .0009 .0007 .0005 .0002 -.0002 -.0005 -.0010
.0020 .0019 .0017 .0015 .0012 .0008 .0003 -.0003 -.0009 -.0016
.0028 .0027 .0024 .0021 .0017 .0011 .0004 -.0004 -.0013 -.0023
.0036 .0034 .0031 .0027 .0021 .0014 .0005 -.0005 -.0016 -.0029
.0044 .0042 .0038 .0033 .0026 .0017 .0007 -.0006 -.0020 -.0036
.0051 .0049 .0045 .0039 .0031 .0020 .0008 -.0007 -.0023 -.0042
.0059 .0057 .0052 .0045 .0035 .0023 .0009 -.0008 -.0027 -.0049
.0067 .0065 .0059 .0051 .0040 .0027 .0010 -.0009 -.0031 -.0055
.0075 .0072 .0066 .0057 .0045 .0030 .0011 -.0010 -.0034 -.0062
TERM=2 /N17B
// CAMBER REPRESENTATION
// BETA-N-2 = (4.*H/YL)*(Y-2.*YL*X+YL) -- WHERE H=.001
INPUT-IMAGE = INPUT, 1ST /N17C
POINTS=ALL $ 0. /N17E,F
POINTS=CENTER /N17E
.0006 .00055 .0005 .00045 .00035 .00025 .0001 -.0001 -.00025 -.0005
.0010 .00095 .00085 .00075 .0006 .0004 .00015 -.00015 -.00045 -.0008
.0014 .00135 .0012 .00105 .00085 .00055 .0002 -.0002 -.00065 -.00115
.0018 .0017 .00155 .00135 .00105 .0007 .00025 -.00025 -.0008 -.00145
.0022 .0021 .0019 .00165 .0013 .00085 .00035 -.0003 -.0010 -.0018
.00255 .00245 .00225 .00195 .00155 .0010 .0004 -.00035 -.00115 -.0021
.00295 .00285 .0026 .00225 .00175 .00115 .00045 -.0004 -.00135 -.00245
.00335 .00325 .00295 .00255 .0020 .00135 .0005 -.00045 -.00155 -.00275
.00375 .0036 .0033 .00285 .00225 .0015 .00055 -.0005 -.0017 -.0031
// END DATA FOR WING NETWORK

```

Figure 8.2 - Continued.

```

// START DATA FOR WAKE NETWORK
// NETWORK IN XY PLANE - NORMAL VECTOR POINTS UPWARD (+Z-AXIS)
// NETWORK EDGE 1 = LEADING EDGE
// NETWORK EDGE 2 = INBOARD EDGE (IN PLANE OF SYMMETRY)
// NETWORK EDGE 3 = TRAILING EDGE
// NETWORK EDGE 4 = OUTBOARD EDGE
NETWORK=WAKE,2,10 /N2A
  1.00000   .51962   0.00000   2.00000   .51962   0.00000
  1.00000   .46188   0.00000   2.00000   .46188   0.00000
  1.00000   .40415   0.00000   2.00000   .40415   0.00000
  1.00000   .34641   0.00000   2.00000   .34641   0.00000
  1.00000   .28868   0.00000   2.00000   .28868   0.00000
  1.00000   .23094   0.00000   2.00000   .23094   0.00000
  1.00000   .17321   0.00000   2.00000   .17321   0.00000
  1.00000   .11547   0.00000   2.00000   .11547   0.00000
  1.00000   .05774   0.00000   2.00000   .05774   0.00000
  1.00000   0.00000   0.00000   2.00000   0.00000   0.00000
BOUNDARY CONDITION=1,4 /N9
// END DATA FOR WAKE NETWORK
// OMIT GEOMETRIC EDGE MATCHING DATA GROUP
// START FLOW PROPERTIES DATA GROUP
BEGIN FLOW PROPERTIES /FP1
// SURFACE FLOW PROPERTIES CASE 1
  SURFACE FLOW PROP=SF-CASE-1
NETWORKS-IMAGES=WING,INPUT /SF2
POINTS = ALL /SF4A
SURFACE SELECTION=UPPER,LOWER,UPLO,AVERAGE /SF5
PRINTOUT=ALL /SF10A
DATA BASE = ALL /SF11A
// START FORCES AND MOMENTS DATA SUBGROUP
FORCES AND MOMENTS /FM1
AXIS SYSTEMS=RCS, 0. 0. 0. /FM3
PRINTOUT=COLSUM,NETWORKS /FM5
DATA BASE = SAME /FM6
// FORCES AND MOMENTS CASE 1
CASE=FM-CASE-1 /FM7
NETWORKS-IMAGES=WING,INPUT /FM8
SURFACE SELECTION=UPLO /FM12
// START PRINT PLOT DATA GROUP
BEGIN PRINT PLOT DATA /PP1
  GEOMETRY DATA /PP2A
  POINT DATA /PP3A
  CONFIGURATION DATA /PP4A
END PROBLEM DEFINITION

```

Figure 8.2 - Concluded.

```

//
// PAN AIR CASE MANUAL CASE 8B
// SUPERSONIC DESIGN PROBLEM
// CONFIGURATION HAS A PURELY SUPERSONIC LEADING EDGE
// THIN DELTA WING AND WAKE, WITH ONE PLANE OF CONFIGURATION SYMMETRY
// SUPERSONIC FLOW, MACH = 2.2, WITH ONE PLANE OF FLOW SYMMETRY
// DESIGN CASE - GIVEN TANGENTIAL VELOCITIES (AVERAGE AND DIFFERENCE SURFACES)
// SOLVE FOR THE THICKNESS AND CAMBER REPRESENTATIONS
// START GLOBAL DATA GROUP
BEGIN GLOBAL DATA /G1
PID= SUPERSONIC DESIGN PROBLEM - DESIGN RUN
UID= USER IDENTIFICATION
// DEFAULT RECORD G4 -
// ONE PLANE OF CONFIGURATION SYMMETRY - NORMAL VECTOR IS +Y-AXIS
MACH=2.2 CALPHA=.573 /G5
// USE DEFAULTS FOR ALL SOLUTION DATA EXCEPT ALPHA AND SOLUTION-ID
ALPHA=.573 /G6-1
SID = SOLUTION-1 /G6-2
// USE VIC-LAMBDA METHOD FOR VELOCITY COMPUTATIONS
SELECTION OF VELOCITY COMPUTATION=VIC-LAMBDA /G9
PRESSURE COEFFICIENT RULES = ISENTROPIC, SECOND-ORDER /G12
CHECKOUT PRINTS=ALL /G17
// START NETWORK DATA GROUP
BEGIN NETWORK DATA /N1
// START DATA FOR WING NETWORK
// NETWORK IN XY PLANE - NORMAL VECTOR POINTS UPWARD (+Z-AXIS)
// NETWORK EDGE 1 = LEADING EDGE
// NETWORK EDGE 2 = INBOARD EDGE (IN PLANE OF SYMMETRY)
// NETWORK EDGE 3 = TRAILING EDGE
// NETWORK EDGE 4 = OUTBOARD EDGE
NETWORK=WING,11,10 /N2A
.90000 .51962 0.00000 .90100 .51962 0.00000
.90400 .51962 0.00000 .90900 .51962 0.00000
.91600 .51962 0.00000 .92500 .51962 0.00000
.93600 .51962 0.00000 .94900 .51962 0.00000
.96400 .51962 0.00000 .98100 .51962 0.00000
1.00000 .51962 0.00000
.80000 .46188 0.00000 .80200 .46188 0.00000
.80800 .46188 0.00000 .81800 .46188 0.00000
.83200 .46188 0.00000 .85000 .46188 0.00000
.87200 .46188 0.00000 .89800 .46188 0.00000
.92800 .46188 0.00000 .96200 .46188 0.00000
1.00000 .46188 0.00000

```

Figure 8.3 - Input for test case 8B.

.70000	.40415	0.00000	.70300	.40415	0.00000
.71200	.40415	0.00000	.72700	.40415	0.00000
.74800	.40415	0.00000	.77500	.40415	0.00000
.80800	.40415	0.00000	.84700	.40415	0.00000
.89200	.40415	0.00000	.94300	.40415	0.00000
1.00000	.40415	0.00000			
.60000	.34641	0.00000	.60400	.34641	0.00000
.61600	.34641	0.00000	.63600	.34641	0.00000
.66400	.34641	0.00000	.70000	.34641	0.00000
.74400	.34641	0.00000	.79600	.34641	0.00000
.85600	.34641	0.00000	.92400	.34641	0.00000
1.00000	.34641	0.00000			
.50000	.28868	0.00000	.50500	.28868	0.00000
.52000	.28868	0.00000	.54500	.28868	0.00000
.58000	.28868	0.00000	.62500	.28868	0.00000
.68000	.28868	0.00000	.74500	.28868	0.00000
.82000	.28868	0.00000	.90500	.28868	0.00000
1.00000	.28868	0.00000			
.40000	.23094	0.00000	.40600	.23094	0.00000
.42400	.23094	0.00000	.45400	.23094	0.00000
.49600	.23094	0.00000	.55000	.23094	0.00000
.61600	.23094	0.00000	.69400	.23094	0.00000
.78400	.23094	0.00000	.88600	.23094	0.00000
1.00000	.23094	0.00000			
.30000	.17321	0.00000	.30700	.17321	0.00000
.32800	.17321	0.00000	.36300	.17321	0.00000
.41200	.17321	0.00000	.47500	.17321	0.00000
.55200	.17321	0.00000	.64300	.17321	0.00000
.74800	.17321	0.00000	.86700	.17321	0.00000
1.00000	.17321	0.00000			
.20000	.11547	0.00000	.20800	.11547	0.00000
.23200	.11547	0.00000	.27200	.11547	0.00000
.32800	.11547	0.00000	.40000	.11547	0.00000
.48800	.11547	0.00000	.59200	.11547	0.00000
.71200	.11547	0.00000	.84800	.11547	0.00000
1.00000	.11547	0.00000			
.10000	.05774	0.00000	.10900	.05774	0.00000
.13600	.05774	0.00000	.18100	.05774	0.00000
.24400	.05774	0.00000	.32500	.05774	0.00000
.42400	.05774	0.00000	.54100	.05774	0.00000
.67600	.05774	0.00000	.82900	.05774	0.00000
1.00000	.05774	0.00000			
0.00000	0.00000	0.00000	.01000	0.00000	0.00000
.04000	0.00000	0.00000	.09000	0.00000	0.00000
.16000	0.00000	0.00000	.25000	0.00000	0.00000
.36000	0.00000	0.00000	.49000	0.00000	0.00000
.64000	0.00000	0.00000	.81000	0.00000	0.00000
1.00000	0.00000	0.00000			

Figure 8.3 - Continued.

```

STORE VIC MATRIX /N3
// SUPERSONIC FLOW MUST USE SINGULARITY TYPES SA AND DA
BOUNDARY CONDITION = 4, 11 1, 12 3 /N9
SINGULARITY TYPE = SA, DA /N11
// NO CLOSURE CONDITION SINCE FLOW IS SUPERSONIC
TANGENT VECTORS FOR DESIGN /N16A
TERM = TA1, TT1, TD2 /N16B
POINTS=ALL /N16E
MID-POINT = 1 /N16G
SPECIFIED FLOW /N17A
// VALUES FROM CASE 8A
TERM=1 /N17B
// BETA-T-1 = TANGENTIAL VELOCITY ON AVERAGE SURFACE
// TANGENTIAL VELOCITIES (=VX) OBTAINED FROM ANALYSIS RUN
INPUT-IMAGES = INPUT, 1ST /N17C
// V-AVERAGE VALUES REQUIRED ONLY AT PANEL CENTER CONTROL POINTS
POINTS = ALL $ 0. /N17E,F
POINTS = CENTER /N17E
.99929 .99929 .99925 .99917 .99908 /AVE-1A
.99898 .99886 .99873 .99856 .99959 /AVE-1B
.99884 .99881 .99876 .99866 .99851 /AVE-2A
.99833 .99884 .99961 1.00005 1.00041 /AVE-2B
.99840 .99834 .99830 .99814 .99792 /AVE-3A
.99896 .99960 1.00007 1.00044 1.00078 /AVE-3B
.99795 .99792 .99781 .99760 .99867 /AVE-4A
.99939 .99989 1.00028 1.00065 1.00104 /AVE-4B
.99751 .99747 .99732 .99808 .99904 /AVE-5A
.99961 1.00002 1.00043 1.00082 1.00121 /AVE-5B
.99712 .99702 .99683 .99858 .99923 /AVE-6A
.99971 1.00009 1.00051 1.00090 1.00133 /AVE-6B
.99668 .99654 .99797 .99883 .99934 /AVE-7A
.99973 1.00013 1.00053 1.00094 1.00140 /AVE-7B
.99623 .99678 .99843 .99898 .99937 /AVE-8A
.99971 1.00011 1.00050 1.00095 1.00143 /AVE-8B
.99579 .99825 .99876 .99904 .99932 /AVE-9A
.99963 1.00002 1.00043 1.00090 1.00145 /AVE-9B
TERM=2 /N17B
// BETA-T-2 = TANGENTIAL VELOCITY ON DIFFERENCE SURFACE
// TANGENTIAL VELOCITIES (=GMUX) OBTAINED FROM ANALYSIS RUN
// VALUES MUST BE GIVEN AT APPROPRIATE PANEL FINE GRID POINTS, RATHER
// THAN CONTROL POINTS, SINCE BOUNDARY CONDITION SPECIFIES GRAD-MU,
// THUS BEING A SINGULARITY SPECIFICATION
INPUT-IMAGES = INPUT, 1ST /N17C
// V-DIFFERENCE VALUES REQUIRED AT ALL POINTS, EXCEPT WHERE EQUATION IS
// REPLACED BY A DOUBLET MATCHING OR KNOWN DOUBLET CONDITION
POINTS = ALL $ 0. /N17E,F

```

Figure 8.3 - Continued.

```

POINTS = CENTER /N17E
.02099 .02215 .02286 .02239 .02139 /DMU/DX-1A
.02013 .01828 .01554 .01157 .00734 /DMU/DX-1B
.01956 .01952 .01924 .01918 .01933 /DMU/DX-2A
.01848 .01638 .01436 .01307 .01222 /DMU/DX-2B
.01873 .01855 .01843 .01862 .01713 /DMU/DX-3A
.01433 .01245 .01166 .01136 .01147 /DMU/DX-3B
.01788 .01755 .01791 .01673 .01353 /DMU/DX-4A
.01155 .01068 .01042 .01038 .01066 /DMU/DX-4B
.01682 .01694 .01677 .01351 .01087 /DMU/DX-5A
.00990 .00948 .00964 .00980 .01025 /DMU/DX-5B
.01593 .01646 .01420 .01055 .00913 /DMU/DX-6A
.00868 .00864 .00900 .00931 .01009 /DMU/DX-6B
.01544 .01495 .01087 .00849 .00781 /DMU/DX-7A
.00769 .00798 .00844 .00901 .00994 /DMU/DX-7B
.01489 .01174 .00796 .00686 .00668 /DMU/DX-8A
.00686 .00740 .00795 .00879 .00959 /DMU/DX-8B
.01147 .00722 .00585 .00560 .00575 /DMU/DX-9A
.00612 .00677 .00748 .00850 .00928 /DMU/DX-9B
POINTS = EDGE /N17E
.02028 .01937 .01831 .01891 .01862 /DMU/DX-E1A
.01447 .01155 .01506 .01696 /DMU/DX-E1B
.00546 .00504 .00515 .00523 .00538 /DMU/DX-E2A
.00568 .00637 .00704 .00831 .00916 /DMU/DX-E2B
.00659 .00630 .00703 .00769 .00814 /DMU/DX-E3A
.00888 .01003 .01058 .00425 /DMU/DX-E3B
.00092 .00381 .00617 .00758 .00820 /DMU/DX-E4A
.00873 .00966 .01021 .00967 .00886 /DMU/DX-E4B
POINTS = ADDITIONAL /N17E
.00000 .00535 .00829 .00000 /DMU/DX-ADD
// END DATA FOR WING NETWORK
// START DATA FOR WAKE NETWORK
// NETWORK IN XY PLANE - NORMAL VECTOR POINTS UPWARD (+Z-AXIS)
// NETWORK EDGE 1 = LEADING EDGE
// NETWORK EDGE 2 = INBOARD EDGE (IN PLANE OF SYMMETRY)
// NETWORK EDGE 3 = TRAILING EDGE
// NETWORK EDGE 4 = OUTBOARD EDGE
NETWORK=WAKE,2,10 /N2A
1.00000 .51962 0.00000 2.00000 .51962 0.00000
1.00000 .46188 0.00000 2.00000 .46188 0.00000
1.00000 .40415 0.00000 2.00000 .40415 0.00000
1.00000 .34641 0.00000 2.00000 .34641 0.00000
1.00000 .28868 0.00000 2.00000 .28868 0.00000
1.00000 .23094 0.00000 2.00000 .23094 0.00000
1.00000 .17321 0.00000 2.00000 .17321 0.00000
1.00000 .11547 0.00000 2.00000 .11547 0.00000
1.00000 .05774 0.00000 2.00000 .05774 0.00000
1.00000 0.00000 0.00000 2.00000 0.00000 0.00000

```

Figure 8.3 - Continued.

```

BOUNDARY CONDITION=1,4 /N9
// END DATA FOR WAKE NETWORK
// OMIT GEOMETRIC EDGE MATCHING DATA GROUP
// START FLOW PROPERTIES DATA GROUP
BEGIN FLOW PROPERTIES /FP1
// SURFACE FLOW PROPERTIES CASE 1
SURFACE FLOW PROPERTIES=PRESSURE-CASE-1 /SF1
NETWORKS-IMAGES=WING,INPUT /SF2
POINTS = ALL /SF4A
SURFACE SELECTION=UPPER,LOWER,UPLO,AVERAGE /SF5
PRINTOUT=ALL /SF10A
DATA BASE = ALL /SF11A
// START FORCES AND MOMENTS DATA SUBGROUP
FORCES AND MOMENTS /FM1
AXIS SYSTEMS=RCS, 0. 0. 0. /FM3
PRINTOUT=COLSUM,NETWORKS /FM5
DATA BASE = SAME /FM6
// FORCES AND MOMENTS CASE 1
CASE = FORCES-MOMENTS-1
NETWORKS-IMAGES=WING,INPUT /FM8
SURFACE SELECTION=UPLO /FM12
// START PRINT PLOT DATA GROUP
BEGIN PRINT PLOT DATA /PP1
GEOMETRY DATA /PP2A
POINT DATA /PP3A
CONFIGURATION DATA /PP4A
END PROBLEM DEFINITION

```

Figure 8.3 - Concluded.

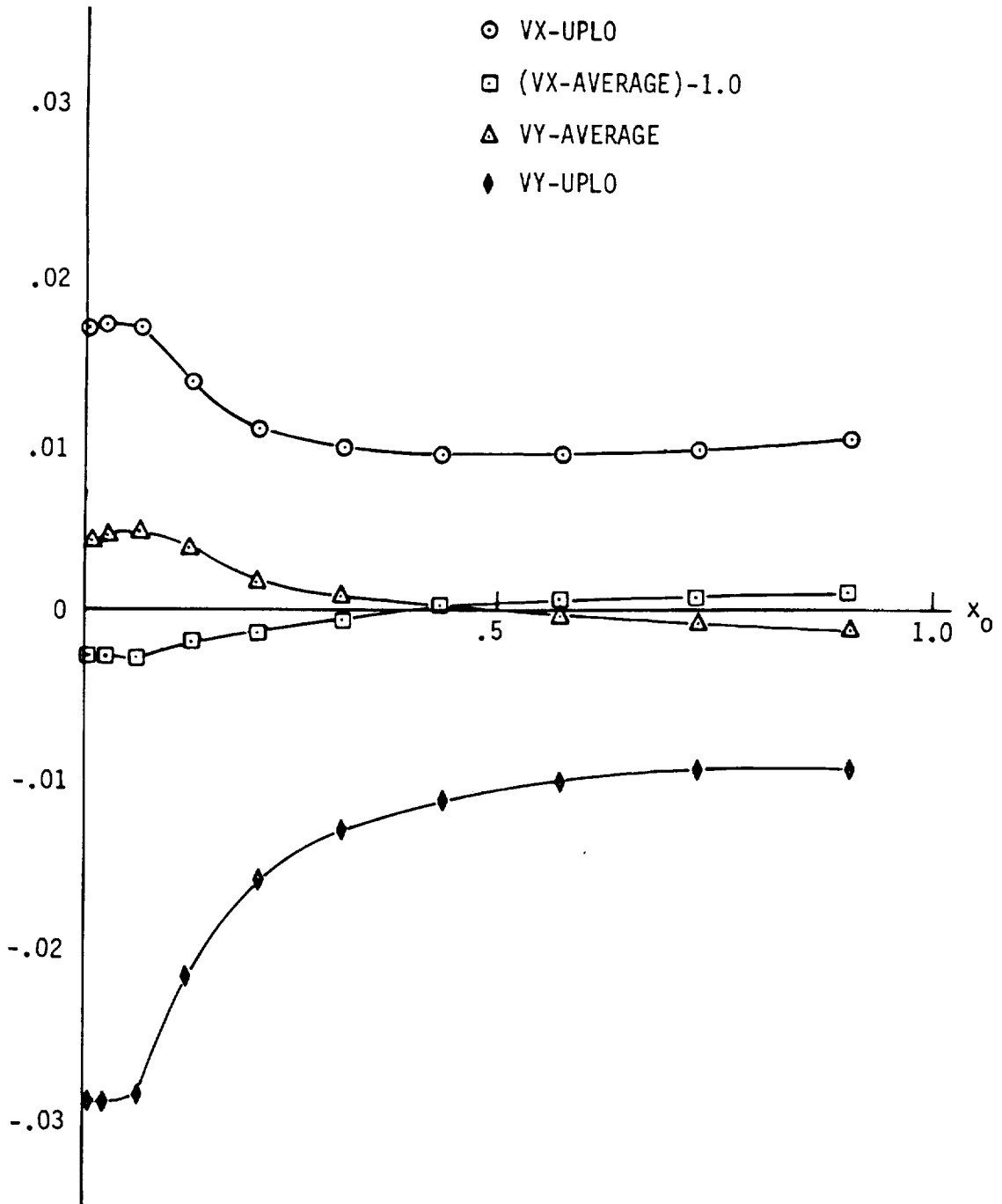

Figure 8.4 - Tangential perturbation velocity components at $y_0 = .25995$ for cases 8A and 8B

9. NACELLE

Purpose

The purpose of this case is to validate the superinclined panel capability of PAN AIR. Superinclined panels are used only in supersonic problems, and because they are superinclined, they do not affect the upstream flow. One application of superinclined panels is to seal off inlet openings so that the perturbation potential can be set to zero in the interior of a body (e.g., a nacelle). If superinclined panels were not used, internal Mach waves would arise which can cause severe numerical error. Another application of superinclined panels is for specifying exhaust flows, but this application is not described here.

Configuration, Flow, and Modeling

The configuration shown in figure 9.1 consists of an axisymmetric flow-through nacelle with a tapered forward portion and a rear portion aligned with the flow. There are four networks as shown in figure 9.2. Network 1 defines the tapered front, network 2 is the cylindrical rear portion of the nacelle, network 3 is the superinclined network at $x_0 = 1.25$, and network 4 is a wake attached to the trailing edge of the nacelle. The upper surfaces of the two nacelle networks are on the outer side of the nacelle, and the upper surface of the superinclined network faces downstream. The four networks define one quarter of the configuration since there are two planes of geometric symmetry. The Mach number is the square root of 2, and the angles of attack and sideslip are zero.

The tapered front of the nacelle causes a perturbation to the freestream which propagates along Mach lines as illustrated in figure 9.2. In the absence of the superinclined network, this disturbance would propagate without diminution through the interior of the nacelle. The mass flux and velocity are discontinuous across such Mach lines (see figure 39 of reference 9.1). Such jumps in flow properties on the interior side of the nacelle can cause numerical error in the solution for the flow about the exterior of the nacelle. The purpose of the superinclined panels is to nullify the disturbance caused by the nacelle lip and thereby produce a more-or-less uniform internal flow. The internal flow will not be exactly uniform because boundary conditions are satisfied only at a finite number of points.

The tapered front of the nacelle is modeled with source singularities alone and zero upper (i.e., outer) surface normal mass flux boundary conditions (see discussion of input below). This modeling does not produce impermeability on the inner surface of the lip, but rather results in a considerable volume of fluid being spewed out of the inner surface. This is not the recommended modeling for a nacelle, but is used here to provide a stringent test for a superinclined network. Ordinarily a doublet-only network would be used to model the tapered, forward portion of the nacelle and this would not spew fluid into the nacelle inlet.

The superinclined network has both source and doublet singularities, with two boundary conditions, one specifying zero perturbation potential and the other specifying zero perturbation normal mass flux, on the upper (i.e., downstream) surface. The specification of two boundary conditions on the same side of a panel is generally improper, but on superinclined panels it is required (see sections B.3.6.6 and A.3 of the User's Manual (ref. 2)) on theoretical grounds. Given sufficiently dense paneling, these boundary conditions produce an unperturbed freestream in the interior of the nacelle downstream from the superinclined network, with the source and doublet strengths on the face being precisely those required to "absorb" the disturbance caused by the nacelle lip.

Given the zero perturbation potential downstream of the superinclined network, the standard class 1 boundary conditions for a thick object may now be imposed on the rear portion of the nacelle. A successful prediction of the pressure distribution on the outer surface of the rear portion of the nacelle by means of these indirect boundary conditions is only possible, however, if the internal flow is an essentially unperturbed freestream.

Input

The input is shown in figure 9.3. Note the use of class 4 boundary conditions for the first and third networks. For the first network, the input values on record G9 correspond to the boundary conditions (see figure 7.7 of the User's Manual):

$$\vec{w}_U \cdot \vec{n} = -\vec{U}_0 \cdot \vec{n} \quad (9.1a)$$

$$\mu = 0 \quad (9.1b)$$

while for the third network the resulting boundary conditions are:

$$\vec{w}_U \cdot \vec{n} = 0 \quad (9.2a)$$

$$\phi_U = 0 \quad (9.2b)$$

Note that the method of velocity computation for network 1 is "nonstagnation" (record N10). The nonstagnation method must be specified for boundary condition classes 4 and 5 whenever the surface velocity is to be computed from the boundary condition method and the perturbation potential on both sides of the surface is not identically zero. The boundary conditions (9.1a) and (9.1b) do not cause the perturbation potential to be zero on either side of the first network, and, therefore, the nonstagnation method must be specified for this network. When PAN AIR uses the nonstagnation method for network 1 the normal mass flux is obtained indirectly from the boundary conditions (i.e., 9.1a), while the potential is obtained from the influence coefficients. The potential is then splined and differentiated to compute the tangential velocity. The tangential velocity is then combined with the normal mass flux to compute all three components of velocity.

The method of velocity computation for network 3 (inlet barrier) is specified to be UPPER-SURFACE-STAGNATION (Record N10) since the perturbation on the upper (i.e., downstream) side is specified to be zero (eq. 9.2b).

Note that if surface velocities for networks 1 and 3 were not to be computed by the BOUNDARY-CONDITION method, then record N10 could have been omitted. Also note that record N10 is only required for boundary condition classes 4 and 5.

Results and Discussion

Results from the PAN AIR pilot code (see INTRODUCTION for references) for two different panel densities are shown in figure 9.4 and are compared there with a theoretical solution (Lighthill, reference 9.2). In figure 9.5, PAN AIR and pilot code results are compared for the case of 96 panels on the superinclined network. For reasons of economy, the PAN AIR solution computed velocities from the boundary conditions (BOUNDARY-CONDITION-METHOD), while the pilot code computed the velocities from the velocity influence coefficients as well (VIC-LAMBDA-METHOD). Pressures computed from the influence coefficients are only shown where they differ measurably from pressures computed from the boundary conditions.

Several items are worth noting here. First, one indication of an inaccurate solution is the disparity between results computed by the BOUNDARY-CONDITION-METHOD and the VIC-LAMBDA-METHOD. Another indication of inaccuracy is a strongly oscillatory solution, such as the pilot code solution for 48 panels.

The modeling used here is one of the most severe possible tests of the superinclined panel capability, since the source-alone modeling of the tapered front generates a large amount of fluid and the indirect impermeability boundary conditions (i.e., class 1, subclasses 1 and 2) are highly sensitive to internal perturbations. Figure 9.4 shows that adding more superinclined panels yields a pressure distribution which is converging toward the correct one, but figure 9.5 shows that with 96 superinclined panels, the resulting PAN AIR numerical solution is far from smooth. In practical cases (i.e., using doublets rather than sources for the nacelle portions upstream of the face) nacelle inlet faces will not be required to nullify such large perturbations. Therefore, 96 or more panels are not necessarily always required.

The most significant error evident in figure 9.5 is in the immediate neighborhood of the point where the Mach wave strikes the inner surface of the nacelle network, showing that the superinclined panels have not completely absorbed the disturbance. As may be expected from the PAN AIR splining techniques, the numerical error also propagates upstream from its source, though to a much lesser degree than it propagates downstream.

REFERENCES

- 9.1 Carmichael, R. L.; and Erickson, L. L.: PAN AIR - A Higher Order Panel Method for Predicting Subsonic or Supersonic Linear Potential Flows about Arbitrary Configurations. AIAA paper 81-1255, June, 1981.
- 9.2 Lighthill, M.J.: Supersonic Flow Past Slender Bodies of Revolution, the Slope of whose Meridian Section is Discontinuous. Quarterly Journal of Mechanics and Applied Mathematics, Vol. I, No. 90, 1948.

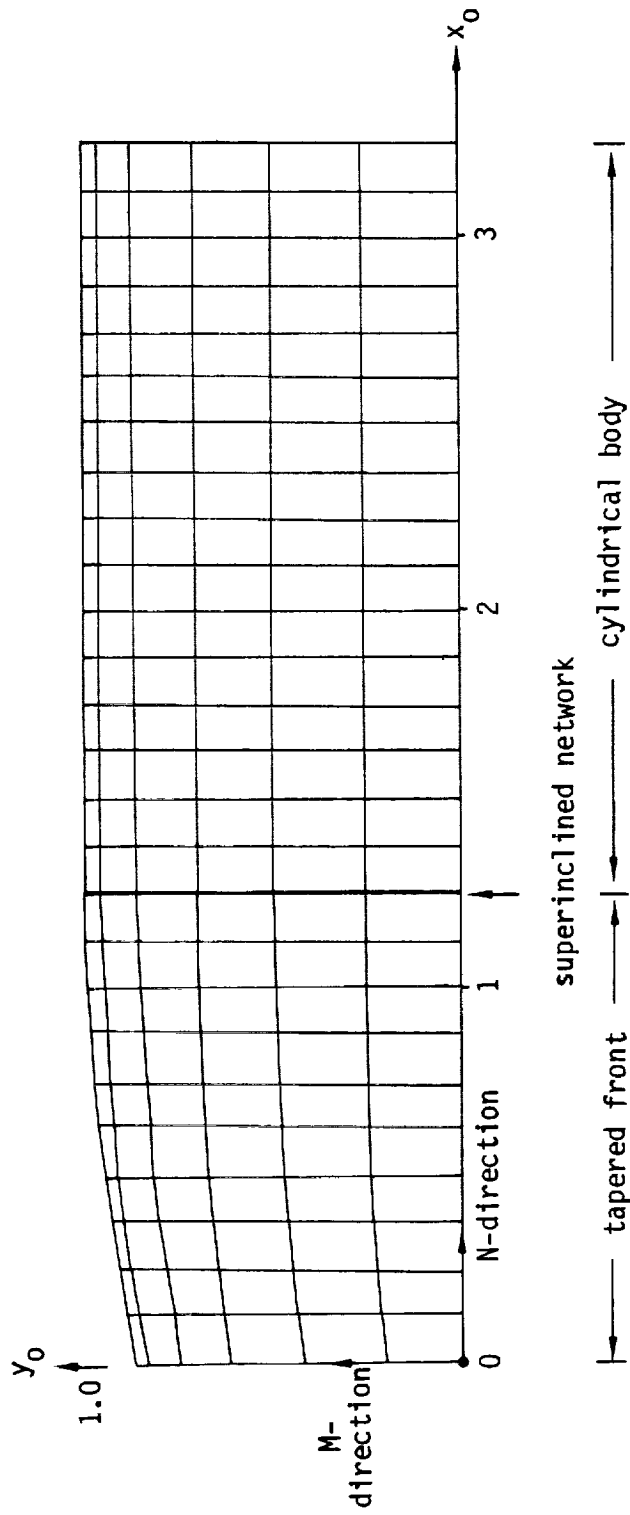

a. Top view (wake not shown)

Figure 9.1 Nacelle paneling

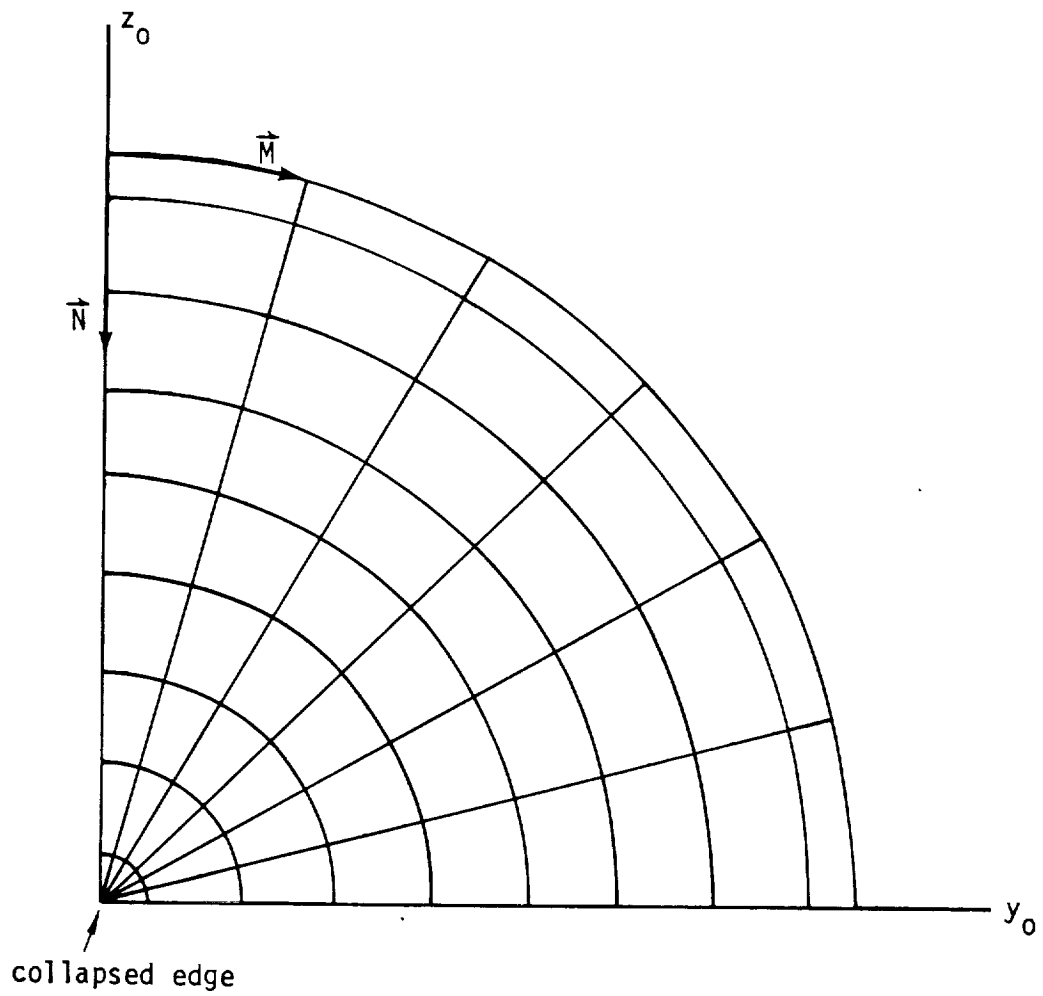

b. Superinclined network

Figure 9.1 Concluded

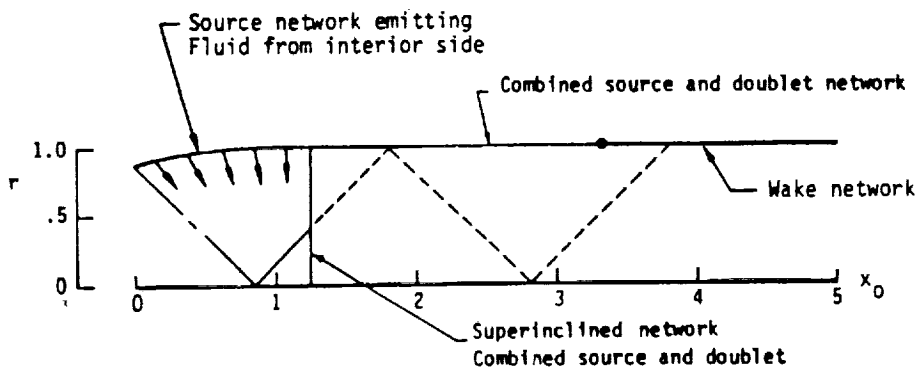

Figure 9.2 - Network arrangement for nacelle, & Mach line pattern

```

// PAN AIR CASE MANUAL CASE 9
// NACELLE WITH SUPERINCLINED NETWORK INSIDE, MACH=1.414
// SIMILAR TO NASA CR-3062, FIGURE 86, P. 227
// VERSION WITH 2 PLANES OF CONFIGURATION AND FLOW SYMMETRY
// CONFIGURATION MODEL HAS 3 NON-WAKE NETWORKS, 252 PANELS
// CONFIGURATION MODEL HAS 1 WAKE NETWORK, 6 PANELS
// (FOR ONE-QUARTER OF ENTIRE CONFIGURATION)
BEGIN GLOBAL DATA /G1
PID=NACELLE WITH SUPERINCLINED NETWORK AS BARRIER, M=1.414
UID=USER IDENTIFICATION
CONFIGURATION = SECOND, SYMMETRIC-FLOW /G4
MACH = 1.414 /G5
// DEFINE 1 SOLUTION, WITH ALPHA=0.
ALPHA = 0. /G6.1
SID = SOLN-1 /G6.2
SURFACE SELECTION = UPPER, LOWER /G8
PRESSURE COEF RULES = ISENTROPIC, SECOND-ORDER /G12
CHECKOUT PRINTS = DIP 1 2 3, DQG 1 2 4 5 6 /G17
BEGIN NETWORK DATA /N1
// START DATA FOR NETWORK 1
NETWORK = TAPERED-FRONT, 7, 11, NEW /N2A
0.00000 0.00000 .87300
0.00000 .22595 .84326
0.00000 .43650 .75604
0.00000 .61731 .61731
0.00000 .75604 .43650
0.00000 .84326 .22595
0.00000 .87300 -.00000
.12500 0.00000 .89713
.12500 .23219 .86656
.12500 .44857 .77694
.12500 .63437 .63437
.12500 .77694 .44857
.12500 .86656 .23219
.12500 .89713 -.00000
.25000 0.00000 .91872
.25000 .23778 .88742
.25000 .45936 .79564
.25000 .64963 .64963
.25000 .79564 .45936
.25000 .88742 .23778
.25000 .91872 -.00000
.37500 0.00000 .93777
.37500 .24271 .90582
.37500 .46889 .81213
.37500 .66310 .66310
.37500 .81213 .46889

```

Figure 9.3 - Input for test case 9.

.37500	.90582	.24271
.37500	.93777	-.00000
.50000	0.00000	.95428
.50000	.24699	.92176
.50000	.47714	.82643
.50000	.67478	.67478
.50000	.82643	.47714
.50000	.92176	.24699
.50000	.95428	-.00000
.62500	0.00000	.96825
.62500	.25060	.93526
.62500	.48413	.83853
.62500	.68466	.68466
.62500	.83853	.48413
.62500	.93526	.25060
.62500	.96825	-.00000
.75000	0.00000	.97968
.75000	.25356	.94630
.75000	.48984	.84843
.75000	.69274	.69274
.75000	.84843	.48984
.75000	.94630	.25356
.75000	.97968	-.00000
.87500	0.00000	.98857
.87500	.25586	.95489
.87500	.49429	.85613
.87500	.69902	.69902
.87500	.85613	.49429
.87500	.95489	.25586
.87500	.98857	-.00000
1.00000	0.00000	.99492
1.00000	.25750	.96102
1.00000	.49746	.86163
1.00000	.70351	.70351
1.00000	.86163	.49746
1.00000	.96102	.25750
1.00000	.99492	-.00000
1.12500	0.00000	.99873
1.12500	.25849	.96470
1.12500	.49937	.86493
1.12500	.70621	.70621
1.12500	.86493	.49937
1.12500	.96470	.25849
1.12500	.99873	-.00000
1.25000	0.00000	1.00000

Figure 9.3 - Continued.

```

1.25000   .25882   .96593
1.25000   .50000   .86603
1.25000   .70711   .70711
1.25000   .86603   .50000
1.25000   .96593   .25882
1.25000   1.00000  -.00000
// NORMAL VECTOR POINTS OUTWARD,
// UPPER SURFACE IS EXPOSED TO EXTERNAL FLOW FIELD
// CLASS 4 BOUNDARY CONDITIONS
// EQUATION 1 - ZERO TOTAL MASS FLUX ON UPPER SURFACE
// EQUATION 2 - ZERO DOUBLET STRENGTH
BOUNDARY CONDITION = 4, 1 1, 8 3 /N9
METHOD OF VELOCITY COMPUTATION = NONSTAGNATION /N10
SINGULARITY TYPES = SA NOD /N11
// END OF DATA FOR NETWORK 1
// START DATA FOR NETWORK 2
NETWORK = CYLINDRICAL-BODY, 7, 17, NEW /N2A
1.25000   0.00000   1.00000
1.25000   .25882   .96593
1.25000   .50000   .86603
1.25000   .70711   .70711
1.25000   .86603   .50000
1.25000   .96593   .25882
1.25000   1.00000  -.00000
1.37500   0.00000   1.00000
1.37500   .25882   .96593
1.37500   .50000   .86603
1.37500   .70711   .70711
1.37500   .86603   .50000
1.37500   .96593   .25882
1.37500   1.00000  -.00000
1.50000   0.00000   1.00000
1.50000   .25882   .96593
1.50000   .50000   .86603
1.50000   .70711   .70711
1.50000   .86603   .50000
1.50000   .96593   .25882
1.50000   1.00000  -.00000
1.62500   0.00000   1.00000
1.62500   .25882   .96593
1.62500   .50000   .86603
1.62500   .70711   .70711
1.62500   .86603   .50000
1.62500   .96593   .25882
1.62500   1.00000  -.00000
1.75000   0.00000   1.00000
1.75000   .25882   .96593

```

Figure 9.3 - Continued.

1.75000	.50000	.86603
1.75000	.70711	.70711
1.75000	.86603	.50000
1.75000	.96593	.25882
1.75000	1.00000	-.00000
1.87500	0.00000	1.00000
1.87500	.25882	.96593
1.87500	.50000	.86603
1.87500	.70711	.70711
1.87500	.86603	.50000
1.87500	.96593	.25882
1.87500	1.00000	-.00000
2.00000	0.00000	1.00000
2.00000	.25882	.96593
2.00000	.50000	.86603
2.00000	.70711	.70711
2.00000	.86603	.50000
2.00000	.96593	.25882
2.00000	1.00000	-.00000
2.12500	0.00000	1.00000
2.12500	.25882	.96593
2.12500	.50000	.86603
2.12500	.70711	.70711
2.12500	.86603	.50000
2.12500	.96593	.25882
2.12500	1.00000	-.00000
2.25000	0.00000	1.00000
2.25000	.25882	.96593
2.25000	.50000	.86603
2.25000	.70711	.70711
2.25000	.86603	.50000
2.25000	.96593	.25882
2.25000	1.00000	-.00000
2.37500	0.00000	1.00000
2.37500	.25882	.96593
2.37500	.50000	.86603
2.37500	.70711	.70711
2.37500	.86603	.50000
2.37500	.96593	.25882
2.37500	1.00000	-.00000
2.50000	0.00000	1.00000
2.50000	.25882	.96593
2.50000	.50000	.86603
2.50000	.70711	.70711
2.50000	.86603	.50000
2.50000	.96593	.25882
2.50000	1.00000	-.00000

Figure 9.3 - Continued.

2.62500	0.00000	1.00000
2.62500	.25882	.96593
2.62500	.50000	.86603
2.62500	.70711	.70711
2.62500	.86603	.50000
2.62500	.96593	.25882
2.62500	1.00000	-.00000
2.75000	0.00000	1.00000
2.75000	.25882	.96593
2.75000	.50000	.86603
2.75000	.70711	.70711
2.75000	.86603	.50000
2.75000	.96593	.25882
2.75000	1.00000	-.00000
2.87500	0.00000	1.00000
2.87500	.25882	.96593
2.87500	.50000	.86603
2.87500	.70711	.70711
2.87500	.86603	.50000
2.87500	.96593	.25882
2.87500	1.00000	-.00000
3.00000	0.00000	1.00000
3.00000	.25882	.96593
3.00000	.50000	.86603
3.00000	.70711	.70711
3.00000	.86603	.50000
3.00000	.96593	.25882
3.00000	1.00000	-.00000
3.12500	0.00000	1.00000
3.12500	.25882	.96593
3.12500	.50000	.86603
3.12500	.70711	.70711
3.12500	.86603	.50000
3.12500	.96593	.25882
3.12500	1.00000	-.00000
3.25000	0.00000	1.00000
3.25000	.25882	.96593
3.25000	.50000	.86603
3.25000	.70711	.70711
3.25000	.86603	.50000
3.25000	.96593	.25882
3.25000	1.00000	-.00000

// NORMAL VECTOR POINTS OUTWARD,
// UPPER SURFACE IS EXPOSED TO EXTERNAL FLOW FIELD
BOUNDARY CONDITION = 1, 1 /N9
// END OF DATA FOR NETWORK 2

Figure 9.3 - Continued.

```

// START DATA FOR NETWORK 3
// FINE PANELING - 96 PANELS IN QUADRANT
NETWORK = INLET-BARRIER, 7, 17, NEW /N2A
1.25000 0.00000 1.00000 1.25000 .25882 .96593
1.25000 .50000 .86603 1.25000 .70711 .70711
1.25000 .86603 .50000 1.25000 .96593 .25882
1.25000 1.00000 -.00000
1.25000 0.00000 .93750
1.25000 .24264 .90556 1.25000 .46875 .81190
1.25000 .66291 .66291 1.25000 .81190 .46875
1.25000 .90556 .24264 1.25000 .93750 -.00000
1.25000 0.00000 .87500 1.25000 .22647 .84519
1.25000 .43750 .75777 1.25000 .61872 .61872
1.25000 .75777 .43750 1.25000 .84519 .22647
1.25000 .87500 -.00000
1.25000 0.00000 .81250
1.25000 .21029 .78481 1.25000 .40625 .70365
1.25000 .57452 .57452 1.25000 .70365 .40625
1.25000 .78481 .21029 1.25000 .81250 -.00000
1.25000 0.00000 .75000 1.25000 .19411 .72444
1.25000 .37500 .64952 1.25000 .53033 .53033
1.25000 .64952 .37500 1.25000 .72444 .19411
1.25000 .75000 -.00000
1.25000 0.00000 .68750
1.25000 .17794 .66407 1.25000 .34375 .59539
1.25000 .48614 .48614 1.25000 .59539 .34375
1.25000 .66407 .17794 1.25000 .68750 -.00000
1.25000 0.00000 .62500 1.25000 .16176 .60370
1.25000 .31250 .54127 1.25000 .44194 .44194
1.25000 .54127 .31250 1.25000 .60370 .16176
1.25000 .62500 -.00000
1.25000 0.00000 .56250
1.25000 .14559 .54333 1.25000 .28125 .48714
1.25000 .39775 .39775 1.25000 .48714 .28125
1.25000 .54333 .14559 1.25000 .56250 -.00000
1.25000 0.00000 .50000 1.25000 .12941 .48296
1.25000 .25000 .43301 1.25000 .35355 .35355
1.25000 .43301 .25000 1.25000 .48296 .12941
1.25000 .50000 -.00000
1.25000 0.00000 .43750
1.25000 .11323 .42259 1.25000 .21875 .37889
1.25000 .30936 .30936 1.25000 .37889 .21875
1.25000 .42259 .11323 1.25000 .43750 -.00000
1.25000 0.00000 .37500 1.25000 .09706 .36222
1.25000 .18750 .32476 1.25000 .26517 .26517
1.25000 .32476 .18750 1.25000 .36222 .09706
1.25000 .37500 -.00000

```

Figure 9.3 - Continued.

1.25000	.08088	.30185	1.25000	0.00000	.31250
1.25000	.22097	.22097	1.25000	.15625	.27063
1.25000	.30185	.08088	1.25000	.27063	.15625
1.25000	0.00000	.25000	1.25000	.31250	-.00000
1.25000	.12500	.21651	1.25000	.06470	.24148
1.25000	.21651	.12500	1.25000	.17678	.17678
1.25000	.25000	-.00000	1.25000	.24148	.06470
1.25000	.04853	.18111	1.25000	0.00000	.18750
1.25000	.13258	.13258	1.25000	.09375	.16238
1.25000	.18111	.04853	1.25000	.16238	.09375
1.25000	0.00000	.12500	1.25000	.18750	-.00000
1.25000	.06250	.10825	1.25000	.03235	.12074
1.25000	.10825	.06250	1.25000	.08839	.08839
1.25000	.12500	-.00000	1.25000	.12074	.03235
1.25000	.01618	.06037	1.25000	0.00000	.06250
1.25000	.04419	.04419	1.25000	.03125	.05413
1.25000	.06037	.01618	1.25000	.05413	.03125
1.25000	0.00000	0.00000	1.25000	.06250	-.00000
1.25000	0.00000	0.00000	1.25000	0.00000	0.00000
1.25000	0.00000	0.00000	1.25000	0.00000	0.00000
1.25000	0.00000	0.00000	1.25000	0.00000	0.00000
1.25000	0.00000	0.00000	1.25000	0.00000	0.00000
1.25000	0.00000	0.00000	1.25000	0.00000	0.00000

// SUPERINCLINED NETWORK
// NORMAL VECTOR POINTS AFTWARD
// LOWER SURFACE IS EXPOSED TO EXTERNAL FLOW FIELD
// 2 BOUNDARY CONDITIONS SPECIFIED ON UPPER (DOWNSTREAM) SURFACE
// CLASS 4 BOUNDARY CONDITIONS
BOUNDARY CONDITION = 4, 1 3, 5 3 /N9
METHOD OF VELOCITY COMPUTATION = UPPER-SURFACE-STAGNATION /N10
SINGULARITY TYPES = SA DA /N11
// END OF DATA FOR NETWORK 3
// START DATA FOR NETWORK 4
NETWORK = WAKE, 2, 7, NEW /N2A

3.25000	0.00000	1.00000
4.25000	0.00000	1.00000
3.25000	.25882	.96593
4.25000	.25882	.96593
3.25000	.50000	.86603
4.25000	.50000	.86603
3.25000	.70711	.70711
4.25000	.70711	.70711
3.25000	.86603	.50000
4.25000	.86603	.50000
3.25000	.96593	.25882
4.25000	.96593	.25882

Figure 9.3 - Continued.

```

3.25000  1.00000  -.00000
4.25000  1.00000  -.00000
BOUNDARY CONDITION = 1, 4 /N9
// END OF DATA FOR NETWORK 4
//
BEGIN FLOW PROP DATA /FP1
SURFACE FLOW PROPERTIES = EXTERIOR-NETWORKS /SF1
NETWORKS-IMAGES = 1, INPUT = 2, INPUT /SF2
POINTS = CENTER /SF4A-DEFAULT
PRINTOUT=ALL /SF10A
DATA BASE=ALL /SF11A
SURFACE FLOW PROPERTIES = BARRIER-NETWORK /SF1
NETWORKS-IMAGES = 3 /SF2
POINTS = CENTER /SF4A-DEFAULT
PRINTOUT /SF10A
DATA BASE /SF11A
FORCES AND MOMENTS /FM1
AXIS SYSTEMS = RCS /FM3
CASE = EXTERIOR-NETWORKS /FM7
NETWORKS-IMAGES = 1, INPUT = 2, INPUT /FM8
SURFACE SELECTION = UPLO /FM12
PRESSURE COEFFICIENT RULES = ISENTROPIC / FM16
ACCUMULATE /FM21
CASE = BARRIER-NETWORKS /FM7
NETWORKS-IMAGES = 3, INPUT /FM8
SURFACE SELECTION = UPLO /FM12
PRESSURE COEFFICIENT RULES = ISENTROPIC / FM16
ACCUMULATE /FM21
BEGIN PRINT PLOT DATA /PP1
GEOMETRY DATA /PP2A
POINT DATA /PP3A
CASES = 1 /PP3B
NETWORKS-IMAGES = 1, INPUT = 2, INPUT /PP3D
CASES = 2 /PP3B
NETWORKS-IMAGES = 3, INPUT /PP3D
CONFIGURATION DATA /PP4A
CASES = 1 /PP4B
NETWORKS-IMAGES = 1, INPUT = 2, INPUT /PP4D
CASES = 2 /PP4B
NETWORKS-IMAGES = 3, INPUT /PP4D
END PROBLEM DEFINITION

```

Figure 9.3 - Concluded.

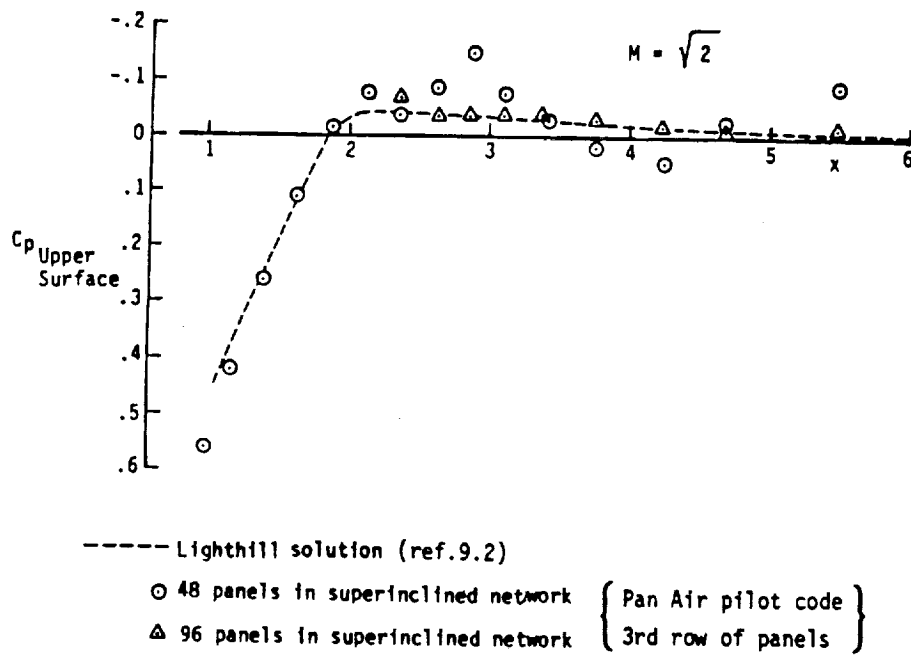

Figure 9.4 - Comparison of pressure distributions on the exterior surface of the nacelle containing an interior superinclined network

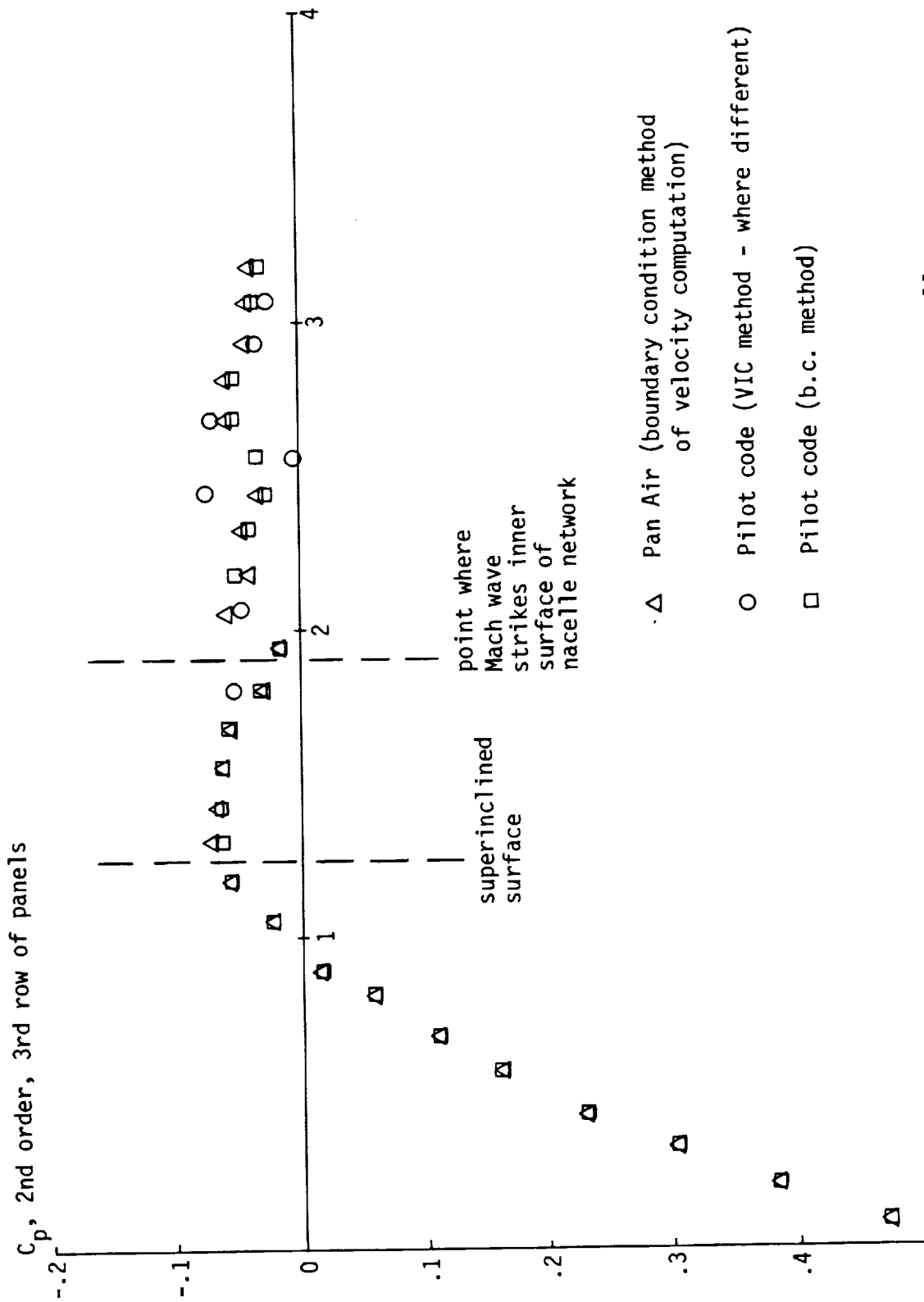

Figure 9.5 - Upper (outer) surface pressures on nacelle

10. ADDED MASS VALIDATION

Richard T. Medan and
David J. Purdon
Boeing Computer Services Company

Purpose

The purpose of the cases described in this section is to demonstrate the numerical correctness of PAN AIR's added mass calculations*. There are five basic types of geometry involved, and for each there exist analytical or experimental data against which PAN AIR can be compared. These geometries and the type of comparative data available are as follows:

1. General triaxial ellipsoids, analytical (ref. 10.1)
2. Elliptical plates, analytical (ref. 10.1)
3. Sheres near a wall, analytical (ref. 10.2)
4. Rectangular plates, experimental (refs. 10.3 and 10.4)
5. Parallelepipeds, experimental (refs. 10.3 and 10.4)

* The results presented in this section were computed with version 1.1 of PAN AIR.

For each of the preceding types of geometries, cases were run for several geometrical parameters (e.g., for several aspect ratios in the elliptical plate cases).

Added mass calculations involve some flow fields that are asymmetrical about any planes of geometric symmetry, excluding ground effect planes. However, version 1.1 of PAN AIR contains an error that does not permit the ASYMMETRIC-FLOW option to be specified (List(2) and List(3) in record G4) in combination with the plane(s) of geometric symmetry option.. Therefore, it was necessary to input the entire geometry and to use the ASYMMETRIC-GEOMETRY option for record G4, except that List(2) and the GROUND-EFFECT option were permitted on record G4 for the sphere near a wall cases. When the ASYMMETRIC-FLOW option is fixed, then only one-fourth as many panels would be required for geometries 1, 2, 4, and 5 above, and only one-half as many panels for geometry 3.

For all of the above geometries there are at most only six added mass coefficients that will be discussed: M_{11} , M_{22} , M_{33} , I_{11} , I_{22} , and I_{33} . M_{11} is a measure of fluid reaction force in the x_0 -direction arising from acceleration of the body in the x_0 -direction. Similarly, M_{22} measures the fluid reaction force in the y_0 -direction arising from acceleration in the y_0 -direction. I_{11} measures the fluid reaction moment about the x_0 -axis due to angular acceleration about the x_0 -axis. Similarly, I_{22} measures the fluid reaction moment about the y_0 -axis due to angular acceleration about the y_0 -axis. For precise definitions of these coefficients, consult the PAN AIR THEORY DOCUMENT (Version 1.1 and later).

In the CDP output, M_{11} is in the row labelled "X" and the column labelled "U", M_{22} is in the row labelled "Y" and the column labelled "V", M_{33} is in the row labelled "Z" and the column labelled "W", I_{11} is in the column labelled "P" and the row labelled "K", etc., as shown in the table that follows:

	U	V	W	K	L	M
X	M_{11}					
Y		M_{22}				
Z			M_{33}			
P				I_{11}		
Q					I_{22}	
R						I_{33}

Additional background on the PAN AIR added mass capability is provided in Appendix E of the Version 1.1 PAN AIR User's Manual.

10.1 Triaxial Ellipsoids

Configuration and Modeling

The triaxial ellipsoids are defined by the following equation:

$$(x_0/a)^2 + (y_0/b)^2 + (z_0/c)^2 = 1$$

The ellipsoid panelling was accomplished using the POTGEM program (ref. 10.5). Another program, PANGEM, was developed that interfaces POTGEM to PAN AIR.

The technique used for panelling the triaxial ellipsoids was to first panel a sphere using cosine spacing in the x_0 -direction and even spacing in the circumferential direction, and then to stretch the sphere (using the POTGEM STRETCH command) into the desired ellipsoid by multiplying all x_0 -values by a , all y_0 -values by b , and all z_0 -values by c . An example of panels so derived is provided in figure 10.1-1.

Each case was modelled using two networks. The first network is in the domain $y_0 \geq 0$, and the second is in the domain $y_0 \leq 0$. The reason for using two networks instead of just one network was that PAN AIR does not permit opposite edges of a network to abut if either of the remaining two edges is collapsed.

For all values of a , b , and c , 6 panels in the x_0 -direction and 24 panels in the circumferential direction (12 on each of the two networks) were used for a total of 144 panels. In addition, 8 panels in the x_0 -direction and 36 panels in the circumferential direction (288 panels total) were used in some cases to assess the adequacy of the panel density.

Input

The DIP input deck for the 6 X 12 network paneling is shown in figure 10.1-2. Note the following:

1. Record G4 was required because, as was previously mentioned, version 1.1 of PAN AIR cannot use the geometric symmetry option with asymmetric flow.
2. Record G5 was not actually required since MACH=0. is the record default. The Mach number should not be anything but zero for added mass runs.
3. Record G8 was not actually required because SURFACE=UPPER is the record default.
4. STORE VIC MATRIX occurs because surface flow properties computed by the VIC-LAMBDA method were desired in addition to the added mass coefficients.
5. Record G18 is the signal to PAN AIR that CDP should print out added mass coefficients and not forces and moments. Record G18 also causes DIP to calculate the correct right hand sides, and, therefore, record set G6 (global onset flow) should not occur in an added mass run. The six right hand sides that are calculated by DIP when G18 is present correspond to flow fields seen by the body when it has unit speed along each of the axes (solutions 1, 2, and 3) or unit angular velocity about each of the axes (solutions 4, 5, and 6).
6. Record N7 was not actually required, since a global tolerance of 1.E-10 was already established in the GLOBAL (G) records.

7. The three solutions specified by record SF3 correspond to unit magnitude flow along the $-x_0$, $-y_0$, and $-z_0$ axes, respectively.
8. Records FI13 and FM4 were not required.

Results and Discussion

Some early results obtained for the case of the sphere indicated that the added mass coefficients as calculated by PAN AIR were somewhat low even though the surface potential was quite accurate. This suggested that the results could be improved by some simple geometrical factors to account for the fact that the panel models of the ellipsoids have less surface area and volume than the true ellipsoids they are meant to represent. POTGEM calculates the surface area of the configurations it panels (i.e., it adds up the areas of each of the individual panels), but it does not calculate volumes enclosed within configurations, and neither does PAN AIR. Therefore, the simple geometrical correction factors could, without any computer code modifications, be obtained only from the ratio of the exact area of the ellipsoids to the panelled area of the ellipsoids. In particular, dimensional analysis shows that the M_{ij} coefficients (i.e., those with row labels of X, Y, and Z and column labels of U, V, and W in the CDP output) should be multiplied by the area ratio raised to the 3/2 power and the I_{ij} coefficients (i.e., those with row labels of K, L, and M and column labels of P, Q, and R) should be multiplied by the area ratio raised to the 5/2 power. Multiplying the results by these correction factors is exactly equivalent to analyzing ellipsoids that are uniformly dilated such that the sum of the areas of the panels is equal to the true surface area of the ellipsoid being modelled. Table 10.1-1 shows the correction factors for all ellipsoids that were to have been analyzed.

Tables 10.1-2 and 10.1-3 show the corrected, and theoretically non-zero coefficients for all cases analyzed and compare them to analytical results (Note that the reference area and length were 1.0 by default and that the reference density is 2.0 in PAN AIR.). Most of the analytical results were read from graphs given in reference 10.1 and are themselves subject to some error.

Perfect symmetry in the PAN AIR results is not prevalent where it should be prevalent (e.g., M_{11} , M_{22} , and M_{33} should all be equal for the sphere). Also, some of the off-diagonal coefficients (not shown) were non-zero. These anomalies occurred partly because of round-off error, but primarily because of asymmetry in the boundary conditions (the edge of one network has an aerodynamic boundary condition, while the corresponding edge of the adjoining network has a matching boundary condition).

The PAN AIR results are least accurate in the extreme cases (e.g., $a=10$, $b=1$, $c=0.1$). Of the extreme cases, the one of most interest is the case $a=10$, $b=c=1$, because this is most like a submarine hull. Considering, however, that this same accuracy can be obtained with only half as many panels once the ASYMMETRIC-FLOW option is fixed, the results seem satisfactory.

The increased accuracy arising from using the previously-described correction factors suggests that this same technique should be useful for all cases in which the panel model does not accurately describe the true surface of the real model. The correction, as noted above, can be effected a priori by uniformly increasing each panel's size such that the panelled area equals the true area, or it may be effected a posteriori (as in the present case) by applying correction factors to the results printed by PAN AIR's CDP module.

10.2 Elliptical Plates

Configuration and Modeling

The equations describing the elliptical plates are as follows:

$$(y_0/a)^2 + (z_0/b)^2 = 1$$

and

$$x_0 = 0$$

POTGEM was again used to develop the paneling. The technique used in POTGEM was similar to the technique used for the ellipsoids. In particular, panels for a circular disk were developed and then the circular disk was stretched into the appropriate elliptical plate. The panel distribution on the disk before stretching was semi-cosine radially (with the densest panels being at the outer edge) and uniform circumferentially. After being stretched, the circumferential paneling is not uniform, but is such that panels are more concentrated in regions of high curvature. An example is provided in figure 10.2-1.

Again, it was necessary to model each case using two networks. The first network is in the domain $z_0 \geq 0$, while the second is in the domain $z_0 \leq 0$.

The number of panels was increased with the aspect ratio because it was anticipated that this would be necessary to keep the error more or less constant.

Input

The DIP input deck for the $a=2$, $b=1$ case is shown in figure 10.2-2. Note the following:

1. SURFACE = AVERAGE in the global data set is used because both surfaces of the elliptical plate are exposed to the flow.
2. AXIS SYSTEMS = RCS and SOLUTIONS = 1 2 3 4 5 6 in the flow properties data set are not required.

Results and Discussion

As in the case of the ellipsoids, the panel representations of the elliptical plates always had less surface area than the true elliptical plates that the panels are supposed to represent. Therefore, the same corrections were applied to the elliptical plate cases. In particular, M_{11} was multiplied by the 3/2 power of the ratio of the exact surface area to the paneled surface area and I_{22} and I_{33} were multiplied by the 5/2 power of this ratio (M_{11} , I_{22} , and I_{33} are, theoretically, the only non-zero added mass coefficients for this geometry). These correction factors are shown in Table 10.2-1.

Corrected PAN AIR M_{11} and I_{11} coefficients are compared with analytical results in Tables 10.2-2 and 10.2-3. It is evident that the correction factors are not as effective in reducing errors as they are for the triaxial ellipsoid cases. Also the rate of increase of panel density with aspect ratio was greater than required to keep the error relatively constant. Figure 10.2-3 is a convergence plot for M_{11} for the circular disk. A smooth curve can be faired between the origin and the three data points and this provides some additional evidence of the correctness of the PAN AIR added mass calculations.

10.3 Spheres Near a Wall

Configuration and Modeling

The configuration consists of a unit radius sphere centered at the origin, plus a ground plane defined by the equation $z_0=h$. The values of h considered are 1.1, 1.5, 2.0, 3.0, and infinity.

Again, it was necessary to model each case using two networks. The first network is in the domain $y_0 \geq 0$, while the second is in the domain $y_0 \leq 0$.

The panelling was accomplished using POTGEM in the same way as for the triaxial ellipsoids. The same panelling density was used for all values of h (but this density was not the same as that used for the triaxial ellipsoids). In particular, there were 8 cosine-spaced panels in the longitudinal direction (x_0 -direction) and 16 uniformly-spaced panels (8 on each network) circumferentially, as shown in figure 10.3-1.

Input

The input for the case $h=1.1$ is shown in figure 10.3-2. Note the following:

1. The CONFIGURATION = FIRST ... record defines the ground effect plane as the plane $z_0=1.1$.
2. The record MACH = 0. could have been omitted.
3. The records AXIS SYSTEMS = RCS and SOLUTIONS = 1 2 3 4 5 6 also could have been omitted.

Results and Discussion

The uncorrected M_{11} , M_{22} , and M_{33} coefficients calculated by PAN AIR are shown in Table 10.3-1 (These are the only theoretically non-zero coefficients). To isolate the wall effects and eliminate the need for correction factors, the coefficients for finite h were divided by the corresponding coefficients for infinite h . These ratios and the corresponding deviations from the analytical result in Figure 62.B in ref. 10.2 are presented in Table 10.3-2.

10.4 Rectangular Plates

Configuration and Modeling

The rectangular plates are defined by the following equations:

$$0 \leq x_0 \leq 2a$$

$$0 \leq y_0 \leq 2b$$

and

$$z_0 = 0$$

where $2a = 1$ and $2b$ takes on the values 1.0, 1.5, 1.75, 2.0, 3.0, 4.0, 5.0, and 10.0.

Cosine spacing was used in both the x_0 and y_0 directions. The number of panels in the x_0 direction was 6, while the number of panels in the y_0 -direction was increased as b was increased. The paneling for the case $b=1.5$ is shown in figure 10.4-1.

Only one network was required for each of these cases.

Input

The input for the case $b=1.5$ is shown in figure 10.4-2. Note the following:

1. Record G5 was not required.
2. SURFACE SELECTION = AVERAGE was used since both surfaces of the network are exposed to the flow.
3. The record AXIS SYSTEM = RCS was not required.

4. Record FM8 was not required.

Results and Discussion

Nondimensional M_{33} added mass coefficients (i.e., the coefficients for motion of the plates normal to themselves) calculated by PAN AIR are presented in Table 10.4-1 and are compared to experimental results in figure 10.4-3. The experimental coefficients were derived from observations of the natural frequencies of the plates immersed in water and connected to springs. There is a rather large discrepancy with the experimental coefficients always being greater than the PAN AIR coefficients. Possible reasons for this discrepancy are as follows:

1. The experimental data are for finite thickness plates. The variation with thickness is very large for small thicknesses as can be seen from figure 2 of reference 10.4.
2. In the experiments, boundary layers arise which, due to their displacement effect, cause the plates to appear larger to the flow fields than they really are.
3. Reference 10.3 shows a significant effect of oscillation magnitude and frequency on the results, yet none of the experimental results in figure 10.4-3 are corrected for these effects.

As a consequence, the discrepancy should not be taken as evidence of errors in the added mass formulation or coding for PAN AIR. Furthermore, note that the exact analytical result for a two dimensional flat plate is also presented in figure 10.4-3 and that this result lies below some of the experimental data even though the latter are for finite aspect ratio plates. This is further evidence that the discrepancies between PAN AIR and experiment are not an indication of errors in PAN AIR.

10.5 Parallelepipeds

Configuration and Modeling

The equations defining the parallelepipeds are the following:

$$0 \leq x_0 \leq 2a$$

$$0 \leq y_0 \leq 2b$$

and

$$0 \leq z_0 \leq 2c$$

where a, b, and c take on sundry values.

POTGEM and PANGEM were again used to generate the panelling. In most cases two panel densities were considered for every value of a, b, and c. The panelling used had the following properties:

1. The panelling on each of the six faces was cosine-spaced in each direction.
2. The number of panels in the x_0 -direction divided into a, the number of panels in the y_0 -direction divided into b, and the number of panels in the z_0 -direction divided into c were made as equal as possible. In other words, the average panel widths in each of the 3 coordinate directions were made as equal as possible.
3. The panelling was compatible at each of the 12 edges of each parallelepiped. That is, corner points abutted corner points.

An example is provided in figure 10.5-1.

As previously stated, version 1.1 of PAN AIR does not allow the planes of geometric symmetry option to be used with unsymmetrical flow. Therefore, it was necessary to use one network for each of the six faces of each parallelepiped. When this error is fixed (i.e., when the ASYMMETRIC-FLOW option on record G4 is permitted), then it will be possible to use only four networks and one-fourth as many panels to get the same result.

Input

The input for the case $a=3$, $b=4$, and $c=2.5$ is shown in figure 10.5-2. Note the following:

1. The STORE VIC MATRIX global data record was used because surface flow properties computed by the VIC method were desired in addition to the added mass coefficients.
2. The PRESSURE = REDUCED global data record is not needed.
3. Unit normals for networks 1, 4, and 6 point outward, and unit normals for networks 2, 3, and 5 point to the interior of the parallelepiped.
4. The NETWORKS = ... record in the forces and moment group and the correct use of the RETAIN and REVERSE options appearing thereon is required since a SURFACE = UPPER record appeared in the global data group and this surface selection was not overridden (by record FM12) in the forces and moments group. Note, however, that if a SURFACE = UPLO record (record FM12) were inserted into the forces and moments group then the NETWORKS = ... record would not have been required because SURFACE=UPLO causes calculation of the net vector force sum, which is independent of the unit normal direction.

Results and Discussion

The M_{11} added mass coefficients (i.e., the coefficients for motion of the parallelepipeds in the x_0 -direction) calculated by PAN AIR are compared with experimental results from refs. 10.3 and 10.4 in Tables 10.5-1 and 10.5-2. Again there are discrepancies between PAN AIR and experiment. Possible reasons for these discrepancies are the same as for the rectangular plate results (except for finite thickness effects) plus, in addition, the results from ref. 10.3 are for a mean displacement-to-diameter ratio of 1.46, which, judging from data presented in ref. 10.3, is far too large for a meaningful comparison. Consequently, the discrepancies should not be taken as evidence of errors in the added mass formulation or coding for PAN AIR.

References

- 10.1 Tuckerman, L. B.: "Inertia Factors of Ellipsoids for use in Airship Design." NACA Report 210, 1925.
- 10.2 Saunder, H. E.: "Hydrodynamics in Ship Design." The Society of Naval Architects and Marine Engineers, Vol. 2, 1957, p. 421.
- 10.3 Patton, K. T.: "An Experimental Determination of Hydrodynamic Masses and Mechanical Impedances." U. S. Navy Underwater Sound Laboratory report 677, October 1965, pp. 58, 59, 72, 73.
- 10.4 Yu, Yee-Tak: "Virtual Masses of Rectangular Plates and Parallelepipeds in Water." Journal of Applied Physics, Vol. 16, Nov. 1965, pp. 724-729.
- 10.5 Medan, R. T. and Bullock, R. B.: "NASA Ames Potential Flow Analysis (POTFAN) Geometry Program (POTGEM) - Version 1." NASA TM X-73127, August 1976.

a	b	c	panels	S_{exact}	S_{panels}	$\left[\frac{S_{\text{exact}}}{S_{\text{panels}}} \right]^{3/2}$	$\left[\frac{S_{\text{exact}}}{S_{\text{panels}}} \right]^{5/2}$
1	1	1	144	12.5664	12.0682	1.0625	1.1064
1	1	1	288	"	12.2935	1.0335	1.0564
2	1	1	144	21.4784	20.5519	1.0684	1.1165
5	1	1	144	50.1925	47.8477	1.0744	1.1271
10	1	1	144	99.1510	94.4312	1.0759	1.1297
10	1	1	288	"	96.5196	1.0412	1.0696
1	1	0.1	144	6.4722	6.1705	1.0742	1.1267
1	1	0.1	288	"	6.3033	1.0405	1.0683
1	1	0.2	144	6.8712	6.5586	1.0723	1.1234
1	1	0.5	144	8.6719	8.3085	1.0663	1.1129
2	1	0.5	144	15.8510*	15.1524	1.0700	1.1193
5	1	0.2	144	33.0350*	31.4964	1.0742	1.1266
10	1	0.1	144	63.7781*	60.8365	1.0734	1.1253
10	1	0.1	288	"	62.1473	1.0396	1.0669

* Computed numerically by POTGEM with 21 X 21 panels on 1/8 of ellipsoid.

Table 10.1-1
Correction factors for added mass coefficients of triaxial ellipsoids.

a	b	c	panels	corrected PAN AIR			theoretical		
				M ₁₁	M ₂₂	M ₃₃	M ₁₁	M ₂₂	M ₃₃
1	1	1	144	4.1829 (-.14)	4.2857 (+2.3)	4.2864 (+2.3)	4.1888	4.1888	4.1888
1	1	1	288	4.2002 (+.27)	4.2440 (+1.3)	4.2440 (+1.3)	"	"	"
2	1	1	144	3.5237 (+.14)	11.967 (+1.4)	11.971 (+1.5)	3.5188	11.799	11.799
5	1	1	144	2.5057 (+1.2)	37.644 (+.49)	37.646 (+.50)	2.4765	37.459	37.459
10	1	1	144	1.7592 (+1.4)	80.132 (-.39)	80.123 (-.40)	1.7347	80.444	80.444
10	1	1	288	1.7376 (+.17)	80.440 (-.01)	80.436 (-.01)	"	"	"
1	1	0.1	144	.06499 (+3.7)	.06362 (+1.5)	4.7981 (-7.4)	.06266	.06266	5.1808
1	1	0.1	288	.06344 (+1.2)	.06325 (+.94)	5.0488 (-2.5)	"	"	"
1	1	0.2	144	.24373 (+2.0)	.24432 (+2.3)	4.9662 (-1.5)	.23884	.23884	5.0395
1	1	0.5	144	1.2998 (+.23)	1.3279 (+2.4)	4.7261 (+1.2)	1.2968	1.2968	4.6708
2	1	0.5	144	1.0720 (+1.1)	3.3898 (+1.6)	12.732 (+.11)	1.0604	3.3357	12.718
5	1	0.2	144	.13408 (+5.5)	1.6095 (+.53)	37.749 (-4.2)	.12706	1.6010	39.389
10	1	0.1	144	.02332 (+6.3)	.82266 (-.47)	75.426 (-8.3)	.02194	.82656	82.274
10	1	0.1	288	.02270 (+3.5)	.82673 (+.02)	79.399 (-3.5)	"	"	"

Note--numbers in parentheses are percentage errors

Table 10.1-2
Comparison of PAN AIR added mass coefficients to theoretical
coefficients for triaxial ellipsoids in linear motion.

a	b	c	panels	corrected PAN AIR			theoretical		
				I ₁₁	I ₂₂	I ₃₃	I ₁₁	I ₂₂	I ₃₃
1	1	.1	144	.00000	.00015	.00015	0	0	0
1	1	1	288	.00000	.00003	.00003	"	"	"
2	1	1	144	.00000	3.9041 (2.7)	3.9017 (-2.7)	0	4.0116	4.0116
5	1	1	144	.00000	144.64 (-5.1)	144.64 (-5.1)	0	152.44	152.44
10	1	1	144	.00000	1396.7 (-6.6)	1396.8 (-6.6)	0	1495.2	1495.2
10	1	1	288	.00000	1449.4 (-3.1)	1449.4 (-3.1)	"	"	"
1	1	0.1	144	.51732 (-24.)	.59623 (-12.)	.00000	.68068	.68068	0
1	1	0.1	288	.62607 (-8.0)	.63698 (-6.4)	.00000	"	"	"
1	1	0.2	144	.57028 (-8.7)	.57976 (-7.2)	.00001	.62488	.62488	0
1	1	0.5	144	.34280 (-3.3)	.34426 (-2.9)	.00006	.35456	.35456	0
2	1	0.5	144	.81181 (-4.6)	6.5691 (-5.3)	1.1959 (-1.7)	.85074	6.9403	1.2163
5	1	0.2	144	3.3638 (-12.)	159.75 (-11.)	6.7350 (-3.0)	3.8088	180.37	6.9460
10	1	0.1	144	6.5188 (-20.)	1313.6 (-18.)	15.120 (-4.8)	8.1866	1598.5	15.875
10	1	0.1	288	7.5342 (-8.0)	1458.0 (-8.8)	15.522 (-2.2)	"	"	"

Note--numbers in parentheses are percentage errors.

Table 10.1-3

Comparison of PAN AIR added mass coefficients to theoretical coefficients for triaxial ellipsoids in angular motion.

a	b	panels	Spanels	$\left[\frac{S_{\text{exact}}}{S_{\text{panels}}}\right]^{3/2}$	$\left[\frac{S_{\text{exact}}}{S_{\text{panels}}}\right]^{5/2}$
1	1	4 X 16*	3.06145	1.03951	1.06672
1	1	5 X 20	3.0917	1.02430	1.04083
1	1	7 X 28	3.11529	1.01269	1.02124
1	0.5	6 X 24	1.55291	1.01732	1.02904
5	1	6 X 36	15.6283	1.00765	1.01279
10	1	10 X 40	31.2869	1.00619	1.01034

* i.e., 4 panels radially and 16 panels circumferentially.

Table 10.2-1
Correction factors for added mass coefficients of elliptical plates.

a	b	panels	PAN AIR M ₁₁	ref. 10.1	percent error
1	1	4 X 16	4.87126	5.33333	-8.7
1	1	5 X 20	4.98334	5.33333	-6.6
1	1	7 X 28	5.12774	5.33333	-3.9
1	0.5	6 X 24	1.64432	1.72940	-4.9
5	1	6 X 36	38.2598	39.8742	-4.0
10	1	10 X 40	80.6474	82.4570	-2.2

Table 10.2-2

Comparison of PAN AIR added mass coefficients to theoretical coefficients for elliptical plates moving normal to themselves.

a	b	panels	PAN AIR I ₂₂ / I ₃₃	ref. 10.1 I ₂₂ / I ₃₃	percent error
1	1	4 X 16	0.57506/ "	0.71111/ "	-19.1 "
1	1	5 X 20	0.61212/ "	0.71111/ "	-13.9 "
1	1	7 X 28	0.64097/ "	0.71111/ "	-7.9 "
1	0.5	6 X 24	.044835/ .245107	.04970/ .27446	-9.8 -10.7
5	1	6 X 36	3.80644/ 169.089	4.14916/ 184.951	-8.2 -8.6
10	1	10 X 40	8.00317/ 1532.42	8.35702/ 1606.35	-4.2 -4.6

Table 10.2-3
Comparison of PAN AIR added mass coefficients to theoretical coefficients
for elliptical plates rotating about minimum and maximum diameters.

h	M ₁₁	M ₂₂	M ₃₃
1.10	4.51343	4.70189	5.39714
1.50	4.14906	4.32295	4.54824
2.00	4.02657	4.19611	4.28701
3.00	3.96521	4.13243	4.15942
infinite	3.93954	4.10611	4.10562

Table 10.3-1
 Added mass coefficients predicted by PAN AIR for
 motion of a sphere near a wall.

$\frac{M_{ij}(h \neq \text{infinity})}{M_{ij}(h = \text{infinity})}$				
h	i=j=1	i=j=2	i=j=2	
1.1	1.14567 (+0.42)	1.14510 (+0.37)	1.31457 (+2.6)	
1.5	1.05318 (-0.23)	1.05281 (-0.26)	1.10781 (-0.3)	
2.0	1.02209 (-0.13)	1.02192 (-0.15)	1.04418 (-0.3)	
3.0	1.00652 (-0.04)	1.00641 (-0.05)	1.01310 (-0.1)	

Table 10.3-2
Wall effects predicted by PAN AIR for a sphere and the percentage deviation of the PAN AIR results from an analytical result.

b/a	panels	$\frac{M_{33}}{2\pi\rho a^2b}$
1.0	6 X 6	.528
1.5	6 X 9	.640
1.75	6 X 11	.678
2.0	6 X 13	.708
3.0	6 X 15	.779
4.0	6 X 20	.819
5.0	6 X 26	.843
10.0	6 X 30	.890

Table 10.4-1
 PAN AIR added mass coefficients for rectangular plates.

2a	2b	2c	panels	$\frac{M_{11}}{8\rho abc}$	
				PAN AIR	Ref. 10.3
1	1	1	5 x 5 x 5	.6295	2.122
2	1	1	7 x 4 x 4	.3300	0.848
3	1	1	9 x 3 x 3	.2238	0.651
4	1	1	11 x 3 x 3	.1701	0.440
5	1	1	12 x 3 x 3	.1372	0.443
6	1	1	13 x 3 x 3	.1150	0.289
7	1	1	14 x 2 x 2	.1008	0.219

Table 10.5-1
Comparison of PAN AIR added mass coefficients to
experimental coefficients for parallelepipeds.

2a	panels	M ₁₁	
		PAN AIR	Ref. 10.4
.15	1 x 7 x 5*	18.85	23.9
.15	1 x 10 x 6	19.10	23.9
.3	1 x 7 x 5	9.862	12.3
.3	1 x 10 x 6	9.958	12.3
1	1 x 7 x 4	3.250	3.97
1	2 x 9 x 6	3.292	3.97
2	2 x 6 x 4	1.741	2.15
2	3 x 8 x 5	1.755	2.15
3	2 x 5 x 4	1.200	1.48
3	5 x 7 x 6	1.220	1.48
4	3 x 5 x 3	.9265	1.14
4	4 x 7 x 5	.9362	1.14
5	3 x 5 x 3	.7546	.955
5	4 x 7 x 4	.7624	.955
6	4 x 5 x 3	.6413	.811

*i.e., 1 panel in the x_0 direction, 7 panels in the y_0 direction, and 5 panels in the z_0 direction

(a) $2b = 8, 2c = 5$

Table 10.5-2
Comparison of PAN AIR added mass coefficients to
experimental coefficients for parallelepipeds.

2a	panels	M ₁₁	
		PAN AIR	Ref. 10.4
.15	1 x 6 x 5	16.90	21.5
.15	1 x 9 x 7	17.19	21.5
.3	1 x 6 x 5	8.847	11.2
.3	1 x 9 x 7	8.962	11.2
1	1 x 6 x 5	2.918	3.62
1	2 x 8 x 7	2.961	3.62
2	2 x 5 x 4	1.560	1.95
2	3 x 7 x 6	1.576	1.95
3	3 x 5 x 4	1.084	1.34
3	3 x 6 x 5	1.086	1.34
4	3 x 4 x 4	.8308	1.06
4	4 x 6 x 5	.8371	1.06
5	3 x 4 x 3	.6730	.868
5	5 x 6 x 5	.6832	.868
6	5 x 5 x 5	.5761	.742
7	6 x 5 x 4	.5001	.654
8	6 x 5 x 4	.4415	.585

(b) 2b = 6, 2c = 5

Table 10.5-2
Continued.

2a	panels	M_{11}	
		$8\rho_{abc}$	
		PAN AIR	Ref. 10.4
.3	1 x 5 x 6	7.313	9.25
.3	1 x 7 x 9	7.401	9.25
1	2 x 5 x 6	2.442	3.10
1	2 x 6 x 8	2.451	3.10
2	2 x 4 x 5	1.293	1.64
2	3 x 6 x 7	1.307	1.64
3	3 x 4 x 4	.8970	1.17
3	4 x 5 x 6	.9033	1.17
4	3 x 3 x 4	.6848	.924
4	5 x 5 x 6	.6949	.924
5	4 x 3 x 4	.5598	.755
5	5 x 4 x 5	.5642	.755
6	6 x 4 x 5	.4771	.669

(c) $2b = 4, 2c = 5$

Table 10.5-2
Concluded.

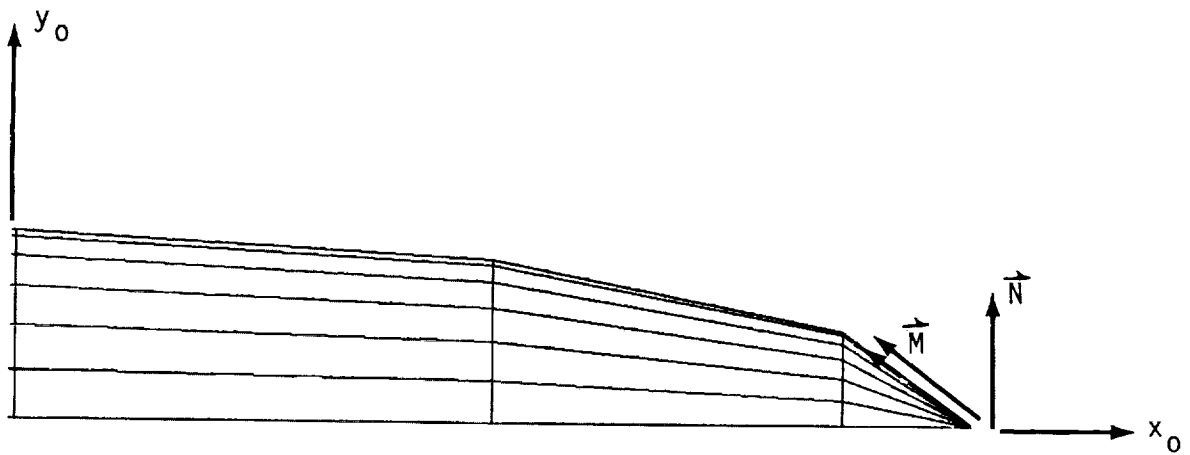

(a) Projection into the $x_0 - y_0$ plane.

Figure 10.1-1. Panels for the rearward half of the $y_0 \geq 0$ network for the triaxial ellipsoid case $a = 5, b = 1, c = 0.2$.

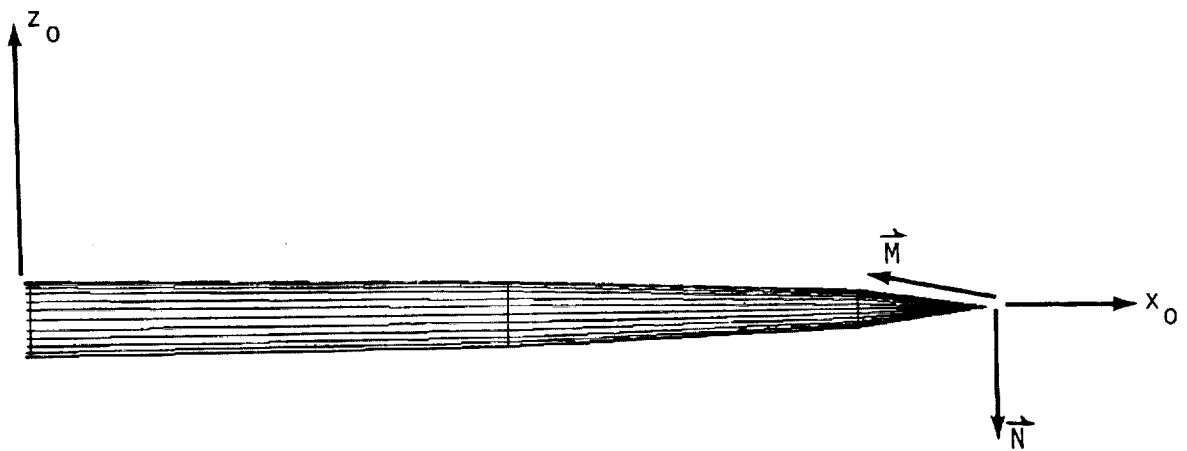

(b) Projection into the $x_0 - z_0$ plane.

Figure 10.1-1. Continued.

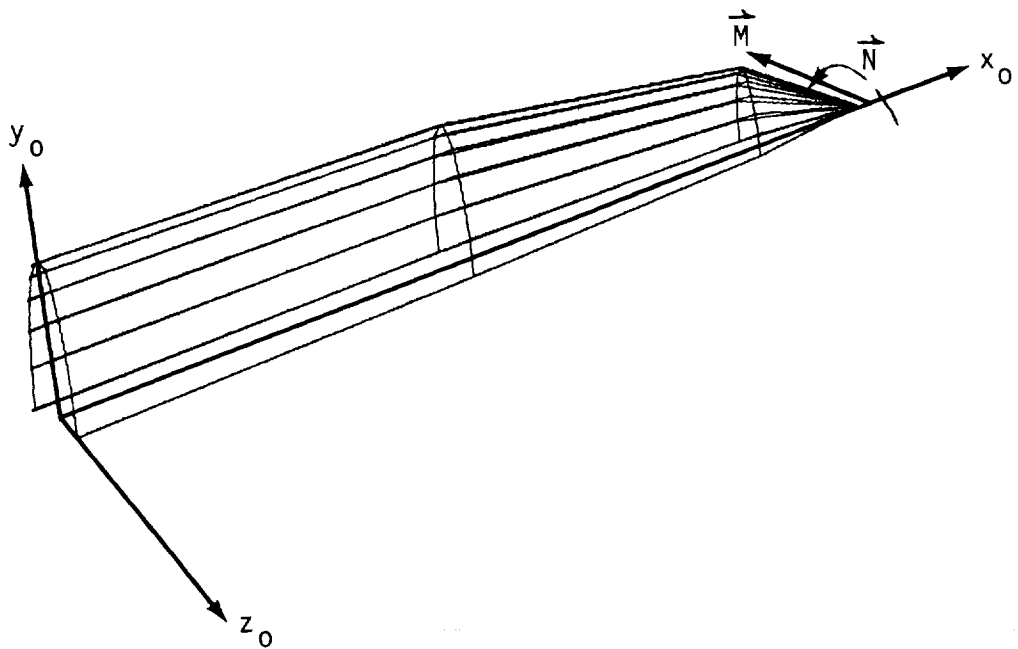

(c) Isometric view.

Figure 10.1-1. Concluded

```

BEGIN GLOBAL /G1
PID=TRIAxIAL ELLIPSOID FOR ADDED MASS CAPABILITY TESTING
UID=R. T. MEDAN, BOEING COMPUTER SERVICES COMPANY, (206) 773 2349
CONFIGURATION = ASYMMETRIC /G4
MACH = 0.0 /G5
TOLERANCE = 1.E-10 /G7
SURFACE = UPPER /G8
CHECKOUT = DEL /G17
STORE VIC MATRIX /G15
PRESSURE RULES = REDUCED /G12
ADDED MASS /G18
BEGIN NETWORK DATA /N1
/NETWORK = HALF-ELLIPSOID-Y-POS = 100
/MAP S TO -COLUMNS
/MAP V TO -ROWS
NETWORK=HALF-ELLIPSOID-Y-POS 7 13 /N2A
5.000000000000 0. 2.1561211432632E-15 /PANGEM
4.330127018922 0. .1000000000000 /PANGEM
2.500000000000 0. .1732050807569 /PANGEM
8.5756224972141E-15 0. .2000000000000 /PANGEM
-2.500000000000 0. .1732050807569 /PANGEM
-4.330127018922 0. .1000000000000 /PANGEM
-5.000000000000 0. 0. /PANGEM
5.000000000000 2.7902260771236E-15 2.0826530968859E-15 /PANGEM
4.330127018922 .1294095225513 9.6592582628907E-02 /PANGEM
2.500000000000 .2241438680420 .1673032607476 /PANGEM
8.5756224972141E-15 .2588190451025 .1931851652578 /PANGEM
-2.500000000000 .2241438680420 .1673032607476 /PANGEM
-4.330127018922 .1294095225513 9.6592582628907E-02 /PANGEM
-5.000000000000 0. 0. /PANGEM
5.000000000000 5.3903028581580E-15 1.8672556837027E-15 /PANGEM
4.330127018922 .2500000000000 8.6602540378444E-02 /PANGEM
2.500000000000 .4330127018922 .1500000000000 /PANGEM
8.5756224972141E-15 .5000000000000 .1732050807569 /PANGEM
-2.500000000000 .4330127018922 .1500000000000 /PANGEM
-4.330127018922 .2500000000000 8.6602540378444E-02 /PANGEM
-5.000000000000 0. 0. /PANGEM
5.000000000000 7.6230394073055E-15 1.5246078814612E-15 /PANGEM
4.330127018922 .3535533905933 7.0710678118656E-02 /PANGEM
2.500000000000 .6123724356958 .1224744871392 /PANGEM
8.5756224972141E-15 .7071067811865 .1414213562373 /PANGEM
-2.500000000000 .6123724356958 .1224744871392 /PANGEM
-4.330127018922 .3535533905933 7.0710678118656E-02 /PANGEM
-5.000000000000 0. 0. /PANGEM

```

Figure 10.1-2. DIP input for the triaxial ellipsoid with $a = 5$, $b = 1$, and $c = 0.2$.

5.000000000000	9.3362784185136E-15	1.0780605716316E-15 /PANGEM
4.330127018922	.4330127018922	5.000000000000E-02 /PANGEM
2.500000000000	.7500000000000	8.6602540378445E-02 /PANGEM
8.5756224972141E-15	.8660254037844	.1000000000000 /PANGEM
-2.500000000000	.7500000000000	8.6602540378444E-02 /PANGEM
-4.330127018922	.4330127018922	5.000000000000E-02 /PANGEM
-5.000000000000	0.	0. /PANGEM
5.000000000000	1.0413265484429E-14	5.5804521542478E-16 /PANGEM
4.330127018922	.4829629131445	2.5881904510253E-02 /PANGEM
2.500000000000	.8365163037378	4.4828773608405E-02 /PANGEM
8.5756224972140E-15	.9659258262891	5.1763809020507E-02 /PANGEM
-2.500000000000	.8365163037378	4.4828773608405E-02 /PANGEM
-4.330127018922	.4829629131445	2.5881904510253E-02 /PANGEM
-5.000000000000	0.	0. /PANGEM
5.000000000000	1.0780605716316E-14	0. /PANGEM
4.330127018922	.5000000000000	0. /PANGEM
2.500000000000	.8660254037844	0. /PANGEM
8.5756224972141E-15	1.0000000000000	0. /PANGEM
-2.500000000000	.8660254037844	0. /PANGEM
-4.330127018922	.5000000000000	0. /PANGEM
-5.000000000000	0.	0. /PANGEM
5.000000000000	1.0413265484429E-14	-5.5804521542474E-16 /PANGEM
4.330127018922	.4829629131445	-2.5881904510252E-02 /PANGEM
2.500000000000	.8365163037378	-4.4828773608402E-02 /PANGEM
8.5756224972140E-15	.9659258262891	-5.1763809020503E-02 /PANGEM
-2.500000000000	.8365163037378	-4.4828773608402E-02 /PANGEM
-4.330127018922	.4829629131445	-2.5881904510252E-02 /PANGEM
-5.000000000000	0.	0. /PANGEM
5.000000000000	9.3362784185136E-15	-1.0780605716316E-15 /PANGEM
4.330127018922	.4330127018922	-4.999999999999E-02 /PANGEM
2.500000000000	.7500000000000	-8.6602540378443E-02 /PANGEM
8.5756224972140E-15	.8660254037844	-9.999999999999E-02 /PANGEM
-2.500000000000	.7500000000000	-8.6602540378443E-02 /PANGEM
-4.330127018922	.4330127018922	-4.999999999999E-02 /PANGEM
-5.000000000000	0.	0. /PANGEM
5.000000000000	7.6230394073057E-15	-1.5246078814611E-15 /PANGEM
4.330127018922	.3535533905933	-7.0710678118654E-02 /PANGEM
2.500000000000	.6123724356958	-.1224744871392 /PANGEM
8.5756224972140E-15	.7071067811866	-.1414213562373 /PANGEM
-2.500000000000	.6123724356958	-.1224744871392 /PANGEM
-4.330127018922	.3535533905933	-7.0710678118654E-02 /PANGEM
-5.000000000000	0.	0. /PANGEM

Figure 10.1-2. Continued.

5.000000000000	5.3903028581582E-15	-1.8672556837027E-15	/PANGEM
4.330127018922	.2500000000000	-8.6602540378443E-02	/PANGEM
2.500000000000	.4330127018922	-.1500000000000	/PANGEM
8.5756224972141E-15	.5000000000000	-.1732050807569	/PANGEM
-2.500000000000	.4330127018922	-.1500000000000	/PANGEM
-4.330127018922	.2500000000000	-8.6602540378443E-02	/PANGEM
-5.000000000000	0.	0.	/PANGEM
5.000000000000	2.7902260771238E-15	-2.0826530968859E-15	/PANGEM
4.330127018922	.1294095225513	-9.6592582628906E-02	/PANGEM
2.500000000000	.2241438680420	-.1673032607476	/PANGEM
8.5756224972140E-15	.2588190451025	-.1931851652578	/PANGEM
-2.500000000000	.2241438680420	-.1673032607476	/PANGEM
-4.330127018922	.1294095225513	-9.6592582628906E-02	/PANGEM
-5.000000000000	0.	0.	/PANGEM
5.000000000000	1.1622145961067E-28	-2.1561211432632E-15	/PANGEM
4.330127018922	5.3903028581581E-15	-1.0000000000000E-01	/PANGEM
2.500000000000	9.3362784185136E-15	-.1732050807569	/PANGEM
8.5756224972140E-15	1.0780605716316E-14	-.2000000000000	/PANGEM
-2.500000000000	9.3362784185136E-15	-.1732050807569	/PANGEM
-4.330127018922	5.3903028581581E-15	-1.0000000000000E-01	/PANGEM
-5.000000000000	0.	0.	/PANGEM

TRIANGULAR PANEL TOLERANCE = 1.E-10 /N7
 BOUNDARY CONDITION = 1 UPPER /N9
 /NETWORK = HALF-ELLIPSOID-Y-NEG = 101
 /MAP S TO COLUMNS
 /MAP V TO -ROWS
 NETWORK=HALF-ELLIPSOID-Y-NEG 7 13 /N2A

5.000000000000	-1.1622145961067E-28	-2.1561211432632E-15	/PANGEM
4.330127018922	-5.3903028581581E-15	-1.0000000000000E-01	/PANGEM
2.500000000000	-9.3362784185136E-15	-.1732050807569	/PANGEM
8.5756224972140E-15	-1.0780605716316E-14	-.2000000000000	/PANGEM
-2.500000000000	-9.3362784185136E-15	-.1732050807569	/PANGEM
-4.330127018922	-5.3903028581581E-15	-1.0000000000000E-01	/PANGEM
-5.000000000000	0.	0.	/PANGEM
5.000000000000	-2.7902260771238E-15	-2.0826530968859E-15	/PANGEM
4.330127018922	-.1294095225513	-9.6592582628906E-02	/PANGEM
2.500000000000	-.2241438680420	-.1673032607476	/PANGEM
8.5756224972140E-15	-.2588190451025	-.1931851652578	/PANGEM
-2.500000000000	-.2241438680420	-.1673032607476	/PANGEM
-4.330127018922	-.1294095225513	-9.6592582628906E-02	/PANGEM
-5.000000000000	0.	0.	/PANGEM

Figure 10.1-2. Continued.

5.000000000000	-5.3903028581582E-15	-1.8672556837027E-15 /PANGEM
4.330127018922	-.2500000000000	-8.6602540378443E-02 /PANGEM
2.500000000000	-.4330127018922	-.1500000000000 /PANGEM
8.5756224972141E-15	-.5000000000000	-.1732050807569 /PANGEM
-2.500000000000	-.4330127018922	-.1500000000000 /PANGEM
-4.330127018922	-.2500000000000	-8.6602540378443E-02 /PANGEM
-5.000000000000	0.	0. /PANGEM
5.000000000000	-7.6230394073057E-15	-1.5246078814611E-15 /PANGEM
4.330127018922	-.3535533905933	-7.0710678118654E-02 /PANGEM
2.500000000000	-.6123724356958	-.1224744871392 /PANGEM
8.5756224972140E-15	-.7071067811866	-.1414213562373 /PANGEM
-2.500000000000	-.6123724356958	-.1224744871392 /PANGEM
-4.330127018922	-.3535533905933	-7.0710678118654E-02 /PANGEM
-5.000000000000	0.	0. /PANGEM
5.000000000000	-9.3362784185136E-15	-1.0780605716316E-15 /PANGEM
4.330127018922	-.4330127018922	-4.9999999999999E-02 /PANGEM
2.500000000000	-.7500000000000	-8.6602540378443E-02 /PANGEM
8.5756224972140E-15	-.8660254037844	-9.9999999999999E-02 /PANGEM
-2.500000000000	-.7500000000000	-8.6602540378443E-02 /PANGEM
-4.330127018922	-.4330127018922	-4.9999999999999E-02 /PANGEM
-5.000000000000	0.	0. /PANGEM
5.000000000000	-1.0413265484429E-14	-5.5804521542474E-16 /PANGEM
4.330127018922	-.4829629131445	-2.5881904510252E-02 /PANGEM
2.500000000000	-.8365163037378	-4.4828773608402E-02 /PANGEM
8.5756224972140E-15	-.9659258262891	-5.1763809020503E-02 /PANGEM
-2.500000000000	-.8365163037378	-4.4828773608402E-02 /PANGEM
-4.330127018922	-.4829629131445	-2.5881904510252E-02 /PANGEM
-5.000000000000	0.	0. /PANGEM
5.000000000000	-1.0780605716316E-14	0. /PANGEM
4.330127018922	-.5000000000000	0. /PANGEM
2.500000000000	-.8660254037844	0. /PANGEM
8.5756224972141E-15	-1.0000000000000	0. /PANGEM
-2.500000000000	-.8660254037844	0. /PANGEM
-4.330127018922	-.5000000000000	0. /PANGEM
-5.000000000000	0.	0. /PANGEM
5.000000000000	-1.0413265484429E-14	5.5804521542478E-16 /PANGEM
4.330127018922	-.4829629131445	2.5881904510253E-02 /PANGEM
2.500000000000	-.8365163037378	4.4828773608405E-02 /PANGEM
8.5756224972140E-15	-.9659258262891	5.1763809020507E-02 /PANGEM
-2.500000000000	-.8365163037378	4.4828773608405E-02 /PANGEM
-4.330127018922	-.4829629131445	2.5881904510253E-02 /PANGEM
-5.000000000000	0.	0. /PANGEM

Figure 10.1-2. Continued.

5.000000000000	-9.3362784185136E-15	1.0780605716316E-15 /PANGEM
4.330127018922	-.4330127018922	5.000000000000E-02 /PANGEM
2.500000000000	-.7500000000000	8.6602540378445E-02 /PANGEM
8.5756224972141E-15	-.8660254037844	.1000000000000 /PANGEM
-2.500000000000	-.7500000000000	8.6602540378444E-02 /PANGEM
-4.330127018922	-.4330127018922	5.000000000000E-02 /PANGEM
-5.000000000000	0.	0. /PANGEM
5.000000000000	-7.6230394073055E-15	1.5246078814612E-15 /PANGEM
4.330127018922	-.3535533905933	7.0710678118656E-02 /PANGEM
2.500000000000	-.6123724356958	.1224744871392 /PANGEM
8.5756224972141E-15	-.7071067811865	.1414213562373 /PANGEM
-2.500000000000	-.6123724356958	.1224744871392 /PANGEM
-4.330127018922	-.3535533905933	7.0710678118656E-02 /PANGEM
-5.000000000000	0.	0. /PANGEM
5.000000000000	-5.3903028581580E-15	1.8672556837027E-15 /PANGEM
4.330127018922	-.2500000000000	8.6602540378444E-02 /PANGEM
2.500000000000	-.4330127018922	.1500000000000 /PANGEM
8.5756224972141E-15	-.5000000000000	.1732050807569 /PANGEM
-2.500000000000	-.4330127018922	.1500000000000 /PANGEM
-4.330127018922	-.2500000000000	8.6602540378444E-02 /PANGEM
-5.000000000000	0.	0. /PANGEM
5.000000000000	-2.7902260771236E-15	2.0826530968859E-15 /PANGEM
4.330127018922	-.1294095225513	9.6592582628907E-02 /PANGEM
2.500000000000	-.2241438680420	.1673032607476 /PANGEM
8.5756224972141E-15	-.2588190451025	.1931851652578 /PANGEM
-2.500000000000	-.2241438680420	.1673032607476 /PANGEM
-4.330127018922	-.1294095225513	9.6592582628907E-02 /PANGEM
-5.000000000000	0.	0. /PANGEM
5.000000000000	0.	2.1561211432632E-15 /PANGEM
4.330127018922	0.	.1000000000000 /PANGEM
2.500000000000	0.	.1732050807569 /PANGEM
8.5756224972141E-15	0.	.2000000000000 /PANGEM
-2.500000000000	0.	.1732050807569 /PANGEM
-4.330127018922	0.	.1000000000000 /PANGEM
-5.000000000000	0.	0. /PANGEM

TRIANGULAR PANEL TOLERANCE = 1.E-10 /N7
 BOUNDARY CONDITION = 1 UPPER /N9

Figure 10.1-2. Continued.

```
BEGIN FLOW PROPERTIES DATA /FP1
SURFACE FLOW = CASE-1      /SF1
NETWORKS = 1               /SF2
SOLUTIONS = 1 2 3         /SF3
POINTS = CENTER           /SF4
SURFACE = UPPER           /SF5
SELECTION = VIC-LAMBDA    /SF6
PRINTOUT = POINT XYZ PVXYZ VMAG PHIT /SF10A
FORCES AND MOMENTS /FM1
AXIS SYSTEMS = RCS       /FM3
DATA BASE = NO          /FM6
SOLUTIONS = 1 2 3 4 5 6 /FM4
CASE = TRI-AXIAL-ELLIPSOID
END OF PROBLEM
```

Figure 10.1-2. Concluded.

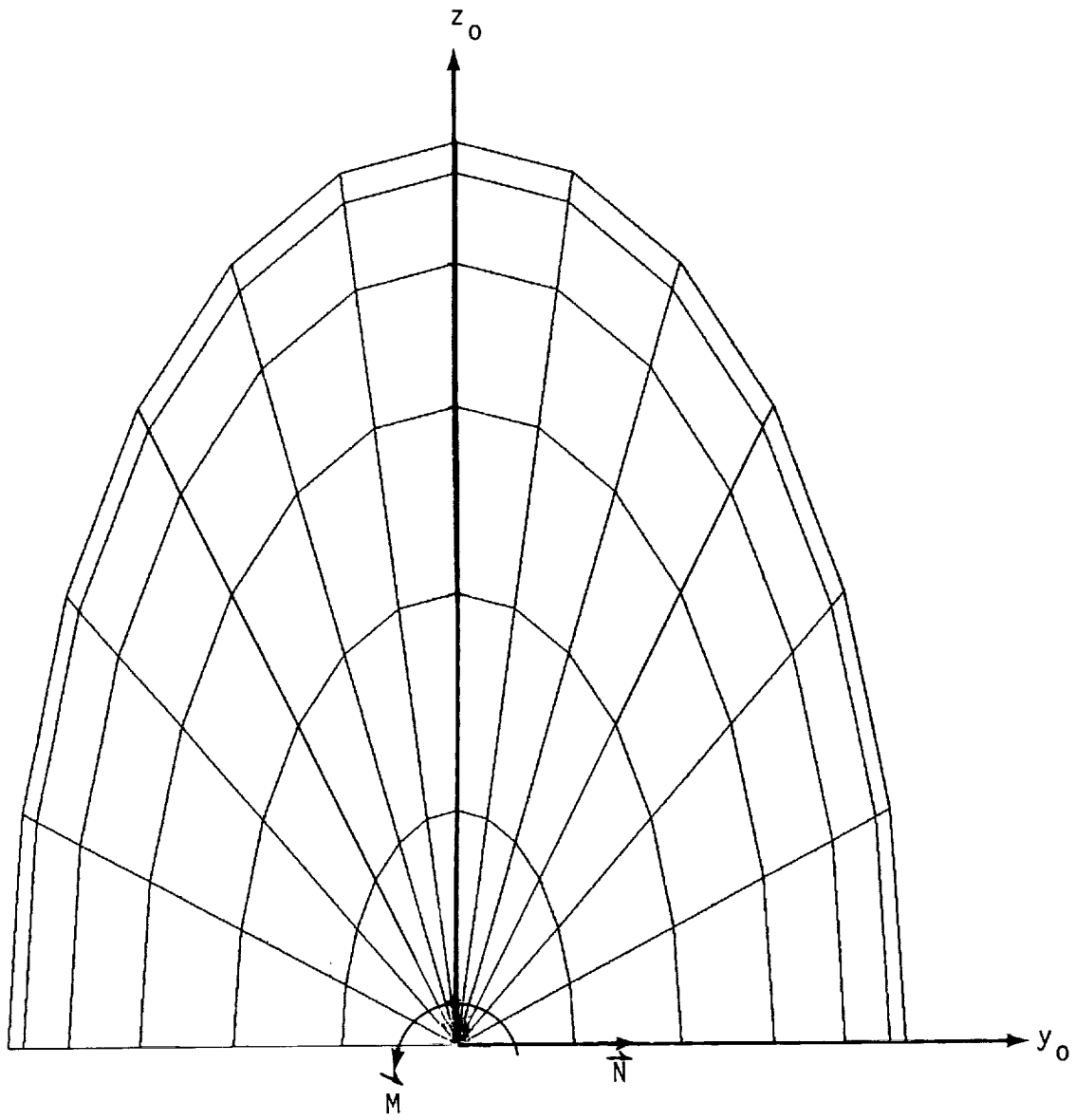

Figure 10.2-1. Elliptical Plate panels for $a/b=2$.

```

BEGIN GLOBAL /G1
PID = ELLIPTICAL PLATE FOR ADDED MASS TESTING
UID = R.T.MEDAN, BCS, (206) 773.2349
CONFIGURATION = ASYMMETRIC /G4
SURFACE = AVERAGE /G8
TOLERANCE = 1.E-10 /G7
CHECKOUT = DIP 1 2 3 , DQG 1 2 4 5 /G17
ADDED MASS /G18
BEGIN NETWORK DATA N1
/NETWORK = HALF-PLATE-Z-POS = 200
NETWORK=HALF-PLATE-Z-POS 13 7 /N2A
0. 0. 0. /PANGEM
0. 0. 0. /PANGEM
0. 0. 0. /PANGEM
0. 0. 0. /PANGEM
0. 0. 0. /PANGEM
0. 0. 0. /PANGEM
0. 0. 0. /PANGEM
0. 0. 0. /PANGEM
0. 0. 0. /PANGEM
0. 0. 0. /PANGEM
0. 0. 0. /PANGEM
0. 0. 0. /PANGEM
0. 0. 0. /PANGEM
0. 0. 0. /PANGEM
0. 0. 0. /PANGEM
0. .1294095232737 0. /PANGEM
0. .1250000006978 6.698729848171E-02 /PANGEM
0. .1120719346466 .1294095232737 /PANGEM
0. 9.1506351456919E-02 .1830127029138 /PANGEM
0. 6.4704761636827E-02 .2241438692932 /PANGEM
0. 3.3493649240860E-02 .2500000013956 /PANGEM
0. 6.9755652317485E-16 .2588190465473 /PANGEM
0. -3.3493649240859E-02 .2500000013956 /PANGEM
0. -6.4704761636825E-02 .2241438692932 /PANGEM
0. -9.1506351456917E-02 .1830127029138 /PANGEM
0. -.1120719346466 .1294095232737 /PANGEM
0. -.1250000006978 6.6987298481719E-02 /PANGEM
0. -.1294095232737 2.7902260926994E-15 /PANGEM

```

Figure 10.2-2. DIP input for the elliptical plate with
 $a = 2$ and $b = 1$.

0.	.2500000005181	0.	/PANGEM
0.	.2414814570728	.1294095228195	/PANGEM
0.	.2165063513948	.2500000005181	/PANGEM
0.	.1767766956630	.3535533913260	/PANGEM
0.	.1250000002591	.4330127027897	/PANGEM
0.	6.4704761409737E-02	.4829629141455	/PANGEM
0.	1.3475757173325E-15	.5000000010363	/PANGEM
0.	-6.4704761409734E-02	.4829629141455	/PANGEM
0.	-.1250000002591	.4330127027897	/PANGEM
0.	-.1767766956630	.3535533913260	/PANGEM
0.	-.2165063513948	.2500000005181	/PANGEM
0.	-.2414814570728	.1294095228195	/PANGEM
0.	-.2500000005181	5.3903028693299E-15	/PANGEM
0.	.3535533909106	0.	/PANGEM
0.	.3415063512526	.1830127020565	/PANGEM
0.	.3061862181227	.3535533909106	/PANGEM
0.	.2500000002244	.5000000004487	/PANGEM
0.	.1767766954553	.6123724362454	/PANGEM
0.	9.1506351028233E-02	.6830127025052	/PANGEM
0.	1.9057598535367E-15	.7071067818211	/PANGEM
0.	-9.1506351028230E-02	.6830127025052	/PANGEM
0.	-.1767766954553	.6123724362454	/PANGEM
0.	-.2500000002244	.5000000004487	/PANGEM
0.	-.3061862181227	.3535533909106	/PANGEM
0.	-.3415063512526	.1830127020565	/PANGEM
0.	-.3535533909106	7.6230394141469E-15	/PANGEM
0.	.4330127020418	0.	/PANGEM
0.	.4182581520134	.2241438681194	/PANGEM
0.	.3750000001295	.4330127020418	/PANGEM
0.	.3061862179537	.6123724359073	/PANGEM
0.	.2165063510209	.7500000002591	/PANGEM
0.	.1120719340597	.8365163040268	/PANGEM
0.	2.3340696054347E-15	.8660254040836	/PANGEM
0.	-.1120719340597	.8365163040268	/PANGEM
0.	-.2165063510209	.7500000002591	/PANGEM
0.	-.3061862179537	.6123724359073	/PANGEM
0.	-.3750000001295	.4330127020418	/PANGEM
0.	-.4182581520134	.2241438681194	/PANGEM
0.	-.4330127020418	9.3362784217386E-15	/PANGEM
0.	.4829629131832	0.	/PANGEM
0.	.4665063509835	.2500000000200	/PANGEM
0.	.4182581519024	.4829629131832	/PANGEM
0.	.3415063509735	.6830127019470	/PANGEM
0.	.2414814565916	.8365163038049	/PANGEM
0.	.1250000000100	.9330127019670	/PANGEM

Figure 10.2-2. Continued.

0.	2.6033163713160E-15	.9659258263665	/PANGEM
0.	-.1250000000100	.9330127019670	/PANGEM
0.	-.2414814565916	.8365163038049	/PANGEM
0.	-.3415063509735	.6830127019470	/PANGEM
0.	-.4182581519024	.4829629131833	/PANGEM
0.	-.4665063509835	.2500000000200	/PANGEM
0.	-.4829629131832	1.0413265485264E-14	/PANGEM
0.	.5000000000000	0.	/PANGEM
0.	.4829629131445	.2588190451025	/PANGEM
0.	.4330127018922	.5000000000000	/PANGEM
0.	.3535533905933	.7071067811865	/PANGEM
0.	.2500000000000	.8660254037844	/PANGEM
0.	.1294095225513	.9659258262891	/PANGEM
0.	2.6951514290791E-15	1.0000000000000	/PANGEM
0.	-.1294095225513	.9659258262891	/PANGEM
0.	-.2500000000000	.8660254037844	/PANGEM
0.	-.3535533905933	.7071067811866	/PANGEM
0.	-.4330127018922	.5000000000000	/PANGEM
0.	-.4829629131445	.2588190451025	/PANGEM
0.	-.5000000000000	1.0780605716316E-14	/PANGEM
BOUNDARY CONDITION = 1 AVERAGE			/N9
/NETWORK = HALF-PLATE-Z-NEG = 201			
NETWORK=HALF-PLATE-Z-NEG	13	7	/N2A
0.	0.	0.	/PANGEM
0.	0.	0.	/PANGEM
0.	0.	0.	/PANGEM
0.	0.	0.	/PANGEM
0.	0.	0.	/PANGEM
0.	0.	0.	/PANGEM
0.	0.	0.	/PANGEM
0.	0.	0.	/PANGEM
0.	0.	0.	/PANGEM
0.	0.	0.	/PANGEM
0.	0.	0.	/PANGEM
0.	0.	0.	/PANGEM
0.	0.	0.	/PANGEM
0.	0.	0.	/PANGEM
0.	.1294095232737	0.	/PANGEM
0.	.1250000006978	-6.6987298481717E-02	/PANGEM
0.	.1120719346466	-.1294095232737	/PANGEM
0.	9.1506351456919E-02	-.1830127029138	/PANGEM
0.	6.4704761636827E-02	-.2241438692932	/PANGEM
0.	3.3493649240860E-02	-.2500000013956	/PANGEM
0.	6.9755652317485E-16	-.2588190465473	/PANGEM
0.	-3.3493649240859E-02	-.2500000013956	/PANGEM

Figure 10.2-2. Continued.

0.	-6.4704761636825E-02	-.2241438692932	/PANGEM
0.	-9.1506351456917E-02	-.1830127029138	/PANGEM
0.	-.1120719346466	-.1294095232737	/PANGEM
0.	-.1250000006978	-6.6987298481719E-02	/PANGEM
0.	-.1294095232737	-2.7902260926994E-15	/PANGEM
0.	.2500000005181	0.	/PANGEM
0.	.2414814570728	-.1294095228195	/PANGEM
0.	.2165063513948	-.2500000005181	/PANGEM
0.	.1767766956630	-.3535533913260	/PANGEM
0.	.1250000002591	-.4330127027897	/PANGEM
0.	6.4704761409737E-02	-.4829629141455	/PANGEM
0.	1.3475757173325E-15	-.5000000010363	/PANGEM
0.	-6.4704761409734E-02	-.4829629141455	/PANGEM
0.	-.1250000002591	-.4330127027897	/PANGEM
0.	-.1767766956630	-.3535533913260	/PANGEM
0.	-.2165063513948	-.2500000005181	/PANGEM
0.	-.2414814570728	-.1294095228195	/PANGEM
0.	-.2500000005181	-5.3903028693299E-15	/PANGEM
0.	.3535533909106	0.	/PANGEM
0.	.3415063512526	-.1830127020565	/PANGEM
0.	.3061862181227	-.3535533909106	/PANGEM
0.	.2500000002244	-.5000000004487	/PANGEM
0.	.1767766954553	-.6123724362454	/PANGEM
0.	9.1506351028233E-02	-.6830127025052	/PANGEM
0.	1.9057598535367E-15	-.7071067818211	/PANGEM
0.	-9.1506351028230E-02	-.6830127025052	/PANGEM
0.	-.1767766954553	-.6123724362454	/PANGEM
0.	-.2500000002244	-.5000000004487	/PANGEM
0.	-.3061862181227	-.3535533909106	/PANGEM
0.	-.3415063512526	-.1830127020565	/PANGEM
0.	-.3535533909106	-7.6230394141469E-15	/PANGEM
0.	.4330127020418	0.	/PANGEM
0.	.4182581520134	-.2241438681194	/PANGEM
0.	.3750000001295	-.4330127020418	/PANGEM
0.	.3061862179537	-.6123724359073	/PANGEM
0.	.2165063510209	-.7500000002591	/PANGEM
0.	.1120719340597	-.8365163040268	/PANGEM
0.	2.3340696054347E-15	-.8660254040836	/PANGEM
0.	-.1120719340597	-.8365163040268	/PANGEM
0.	-.2165063510209	-.7500000002591	/PANGEM
0.	-.3061862179537	-.6123724359073	/PANGEM
0.	-.3750000001295	-.4330127020418	/PANGEM
0.	-.4182581520134	-.2241438681194	/PANGEM
0.	-.4330127020418	-9.3362784217386E-15	/PANGEM

Figure 10.2-2. Continued.

0.	.4829629131832	0.	/PANGEM
0.	.4665063509835	-.2500000000200	/PANGEM
0.	.4182581519024	-.4829629131832	/PANGEM
0.	.3415063509735	-.6830127019470	/PANGEM
0.	.2414814565916	-.8365163038049	/PANGEM
0.	.1250000000100	-.9330127019670	/PANGEM
0.	2.6033163713160E-15	-.9659258263665	/PANGEM
0.	-.1250000000100	-.9330127019670	/PANGEM
0.	-.2414814565916	-.8365163038049	/PANGEM
0.	-.3415063509735	-.6830127019470	/PANGEM
0.	-.4182581519024	-.4829629131833	/PANGEM
0.	-.4665063509835	-.2500000000200	/PANGEM
0.	-.4829629131832	-1.0413265485264E-14	/PANGEM
0.	.5000000000000	0.	/PANGEM
0.	.4829629131445	-.2588190451025	/PANGEM
0.	.4330127018922	-.5000000000000	/PANGEM
0.	.3535533905933	-.7071067811865	/PANGEM
0.	.2500000000000	-.8660254037844	/PANGEM
0.	.1294095225513	-.9659258262891	/PANGEM
0.	2.6951514290791E-15	-1.0000000000000	/PANGEM
0.	-.1294095225513	-.9659258262891	/PANGEM
0.	-.2500000000000	-.8660254037844	/PANGEM
0.	-.3535533905933	-.7071067811866	/PANGEM
0.	-.4330127018922	-.5000000000000	/PANGEM
0.	-.4829629131445	-.2588190451025	/PANGEM
0.	-.5000000000000	-1.0780605716316E-14	/PANGEM
BOUNDARY CONDITION = 1 AVERAGE		/N9	
BEGIN FLOW PROPERTIES DATA		/FP1	
FORCES AND MOMENTS		/FM1	
AXIS SYSTEMS = RCS		/FM3	
SOLUTIONS = 1 2 3 4 5 6		/FM4	
CASE = ELLIPTICAL-PLATE		/FM7	
LOCAL PRINTOUT = COLSUM NETWORK CONFIGURATION		/FM19	
END OF PROBLEM			

Figure 10.2-2. Concluded.

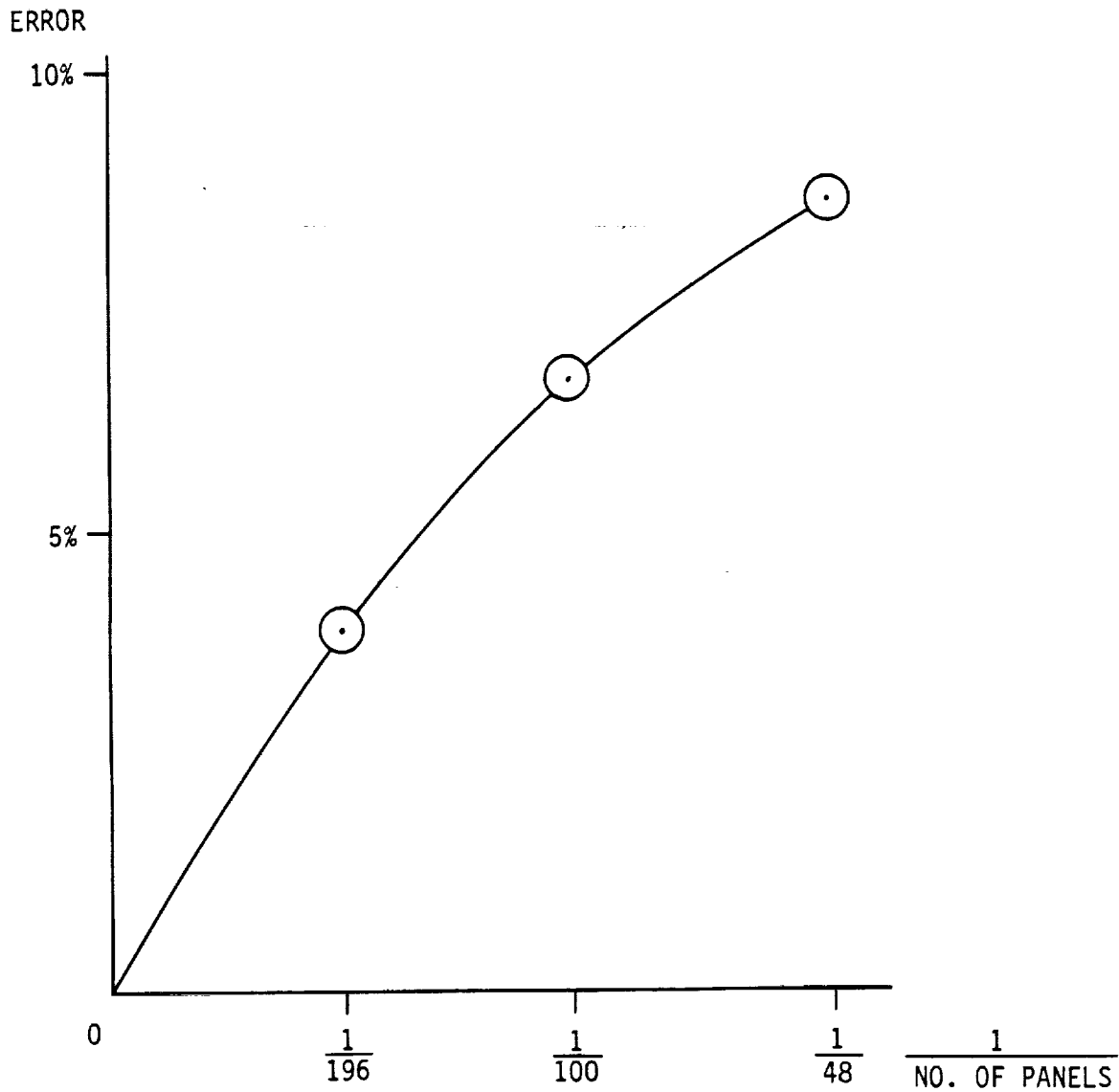
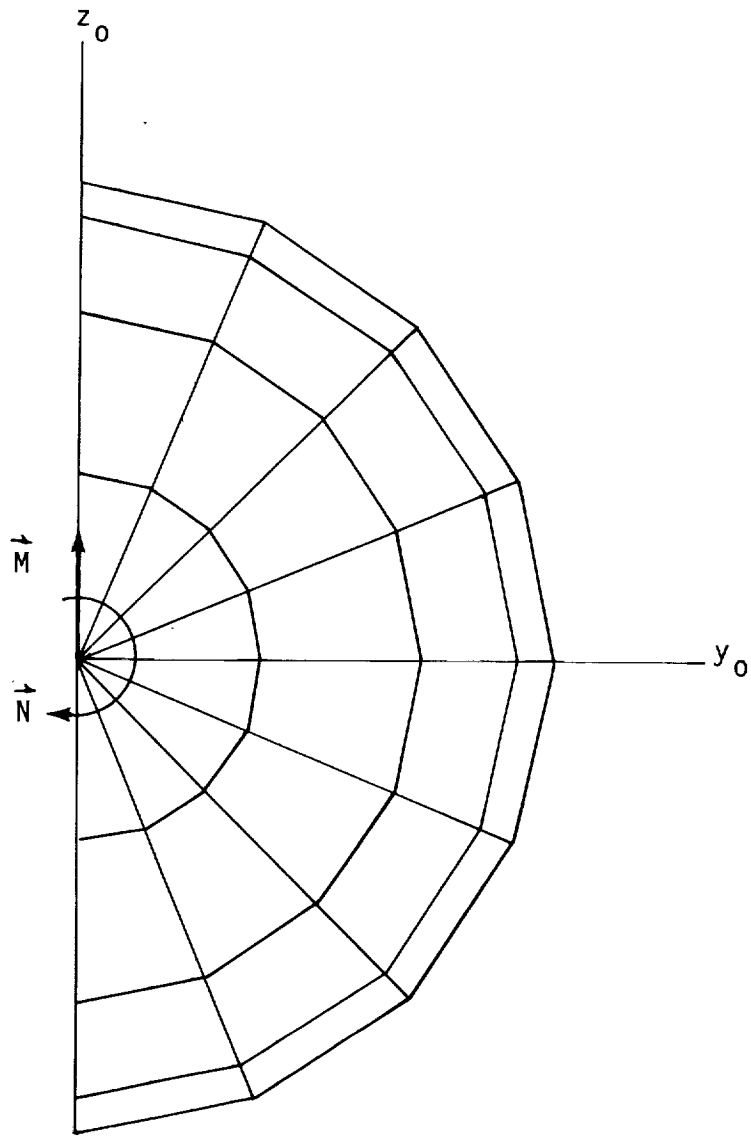
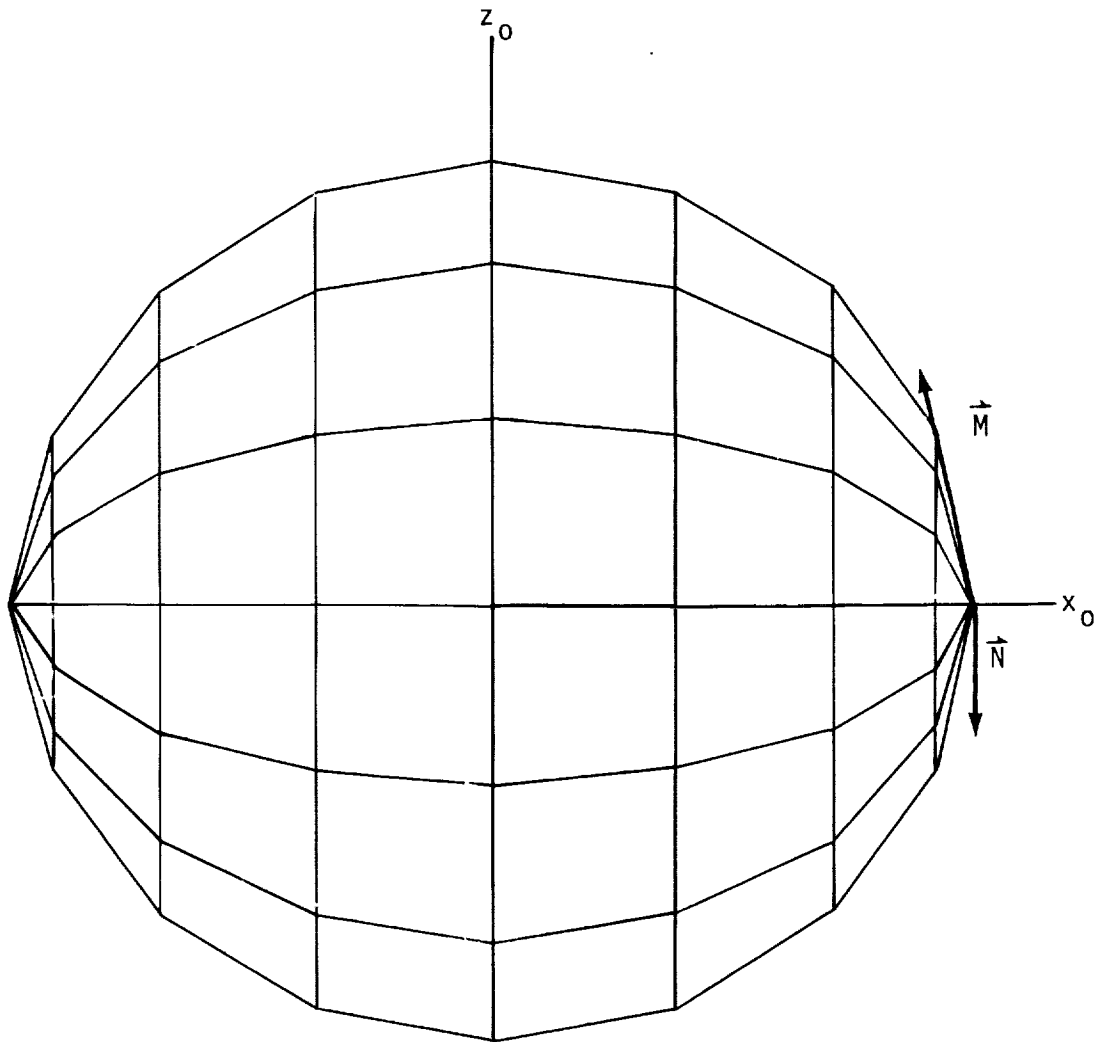

Figure 10.2-3 Convergence of M_{11} with panel density for the case of the circular disk.



(a) Projection into the $y_0 - z_0$ plane

Figure 10.3-1. Panels for the $y_0 \geq 0$ network for the sphere near a wall case.



(b) Projection into the $x_0 - z_0$ plane

Figure 10.3-1. Continued

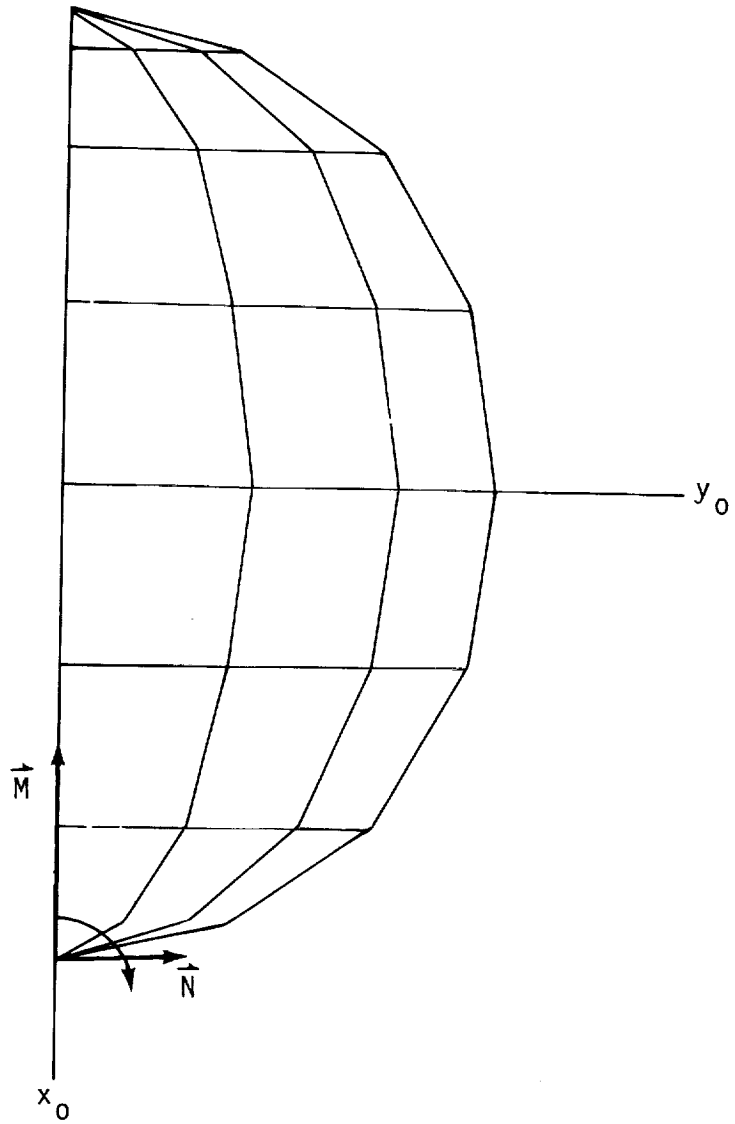

(c) Projection into the $x_0 - y_0$ plane

```

                                /G1
BEGIN GLOBAL
PID = SPHERE NEAR WALL FOR ADDED MASS CAPABILITY TESTING
UID = D.J.PURDON, BCS, (206) 773.2349
/ A PLANE OF GROUND EFFECT RUNS NEAR THE SPHERE OF RADIUS 1.0
CONFIGURATION = FIRST , 0. 0. 1. , 0. 0. 1.1 , GROUND-EFFECT /G4
MACH = 0. /G5
TOLERANCE = 1.E-10 /G7
SURFACE = UPPER /G8
CHECKOUT = ALL /G17
ADDED MASS /G18
BEGIN NETWORK DATA /N1
/NETWORK = HALF-SPHERE-Y-POS = 300
/MAP S TO -COLUMNS
/MAP V TO -ROWS
NETWORK=HALF-SPHERE-Y-POS          9      9
1.0000000000000000          0.          1.0780605716316E-14 /N2A /PANGEM
.9238795325113          0.          .3826834323651 /PANGEM
.7071067811865          0.          .7071067811866 /PANGEM
.3826834323651          0.          .9238795325113 /PANGEM
-5.3903028581581E-15          0.          1.0000000000000 /PANGEM
-.3826834323651          0.          .9238795325113 /PANGEM
-.7071067811865          0.          .7071067811865 /PANGEM
-.9238795325113          0.          .3826834323651 /PANGEM
-1.0000000000000000          0.          0. /PANGEM
1.0000000000000000          4.1255591984946E-15          9.9599809693788E-15 /PANGEM
.9238795325113          .1464466094067          .3535533905933 /PANGEM
.7071067811865          .2705980500731          .6532814824382 /PANGEM
.3826834323651          .3535533905933          .8535533905933 /PANGEM
-5.3903028581581E-15          .3826834323651          .9238795325113 /PANGEM
-.3826834323651          .3535533905933          .8535533905933 /PANGEM
-.7071067811865          .2705980500731          .6532814824382 /PANGEM
-.9238795325113          .1464466094067          .3535533905933 /PANGEM
-1.0000000000000000          0.          0. /PANGEM
1.0000000000000000          7.6230394073056E-15          7.6230394073057E-15 /PANGEM
.9238795325113          .2705980500731          .2705980500731 /PANGEM
.7071067811865          .5000000000000          .5000000000000 /PANGEM
.3826834323651          .6532814824382          .6532814824382 /PANGEM
-5.3903028581581E-15          .7071067811865          .7071067811865 /PANGEM
-.3826834323651          .6532814824382          .6532814824382 /PANGEM
-.7071067811865          .5000000000000          .5000000000000 /PANGEM
-.9238795325113          .2705980500731          .2705980500731 /PANGEM
-1.0000000000000000          0.          0. /PANGEM

```

Figure 10.3-2. DIP input for the sphere 1.1 units from the wall.

1.000000000000	9.9599809693787E-15	4.1255591984946E-15 /PANGEM
.9238795325113	.3535533905933	.1464466094067 /PANGEM
.7071067811865	.6532814824382	.2705980500731 /PANGEM
.3826834323651	.8535533905933	.3535533905933 /PANGEM
-5.3903028581581E-15	.9238795325113	.3826834323651 /PANGEM
-.3826834323651	.8535533905933	.3535533905933 /PANGEM
-.7071067811865	.6532814824382	.2705980500731 /PANGEM
-.9238795325113	.3535533905933	.1464466094067 /PANGEM
-1.000000000000	0.	0. /PANGEM
1.000000000000	1.0780605716316E-14	0. /PANGEM
.9238795325113	.3826834323651	0. /PANGEM
.7071067811865	.7071067811866	0. /PANGEM
.3826834323651	.9238795325113	0. /PANGEM
-5.3903028581581E-15	1.000000000000	0. /PANGEM
-.3826834323651	.9238795325113	0. /PANGEM
-.7071067811865	.7071067811865	0. /PANGEM
-.9238795325113	.3826834323651	0. /PANGEM
-1.000000000000	0.	0. /PANGEM
1.000000000000	9.9599809693788E-15	-4.1255591984945E-15 /PANGEM
.9238795325113	.3535533905933	-.1464466094067 /PANGEM
.7071067811865	.6532814824382	-.2705980500731 /PANGEM
.3826834323651	.8535533905933	-.3535533905933 /PANGEM
-5.3903028581581E-15	.9238795325113	-.3826834323651 /PANGEM
-.3826834323651	.8535533905933	-.3535533905933 /PANGEM
-.7071067811865	.6532814824382	-.2705980500731 /PANGEM
-.9238795325113	.3535533905933	-.1464466094067 /PANGEM
-1.000000000000	0.	0. /PANGEM
1.000000000000	7.6230394073057E-15	-7.6230394073056E-15 /PANGEM
.9238795325113	.2705980500731	-.2705980500731 /PANGEM
.7071067811865	.5000000000000	-.5000000000000 /PANGEM
.3826834323651	.6532814824382	-.6532814824382 /PANGEM
-5.3903028581581E-15	.7071067811866	-.7071067811865 /PANGEM
-.3826834323651	.6532814824382	-.6532814824382 /PANGEM
-.7071067811865	.5000000000000	-.5000000000000 /PANGEM
-.9238795325113	.2705980500731	-.2705980500731 /PANGEM
-1.000000000000	0.	0. /PANGEM
1.000000000000	4.1255591984947E-15	-9.9599809693787E-15 /PANGEM
.9238795325113	.1464466094067	-.3535533905933 /PANGEM
.7071067811865	.2705980500731	-.6532814824382 /PANGEM
.3826834323651	.3535533905933	-.8535533905933 /PANGEM
-5.3903028581581E-15	.3826834323651	-.9238795325113 /PANGEM
-.3826834323651	.3535533905933	-.8535533905933 /PANGEM
-.7071067811865	.2705980500731	-.6532814824382 /PANGEM
-.9238795325113	.1464466094067	-.3535533905933 /PANGEM
-1.000000000000	0.	0. /PANGEM

Figure 10.3-2. Continued.

1.000000000000	1.1622145961067E-28	-1.0780605716316E-14	/PANGEM
.9238795325113	4.1255591984947E-15	-.3826834323651	/PANGEM
.7071067811865	7.6230394073057E-15	-.7071067811865	/PANGEM
.3826834323651	9.9599809693788E-15	-.9238795325113	/PANGEM
-5.3903028581581E-15	1.0780605716316E-14	-1.000000000000	/PANGEM
-.3826834323651	9.9599809693788E-15	-.9238795325113	/PANGEM
-.7071067811865	7.6230394073057E-15	-.7071067811865	/PANGEM
-.9238795325113	4.1255591984946E-15	-.3826834323651	/PANGEM
-1.000000000000	0.	0.	/PANGEM
TRIANGULAR PANEL TOLERANCE =	1.E-10		/N7
BOUNDARY CONDITION = 1 UPPER			/N9
/NETWORK = HALF-SPHERE-Y-NEG = 301			
/MAP S TO COLUMNS			
/MAP V TO -ROWS			
NETWORK=HALF-SPHERE-Y-NEG	9 9		/N2A
1.000000000000	-1.1622145961067E-28	-1.0780605716316E-14	/PANGEM
.9238795325113	-4.1255591984947E-15	-.3826834323651	/PANGEM
.7071067811865	-7.6230394073057E-15	-.7071067811865	/PANGEM
.3826834323651	-9.9599809693788E-15	-.9238795325113	/PANGEM
-5.3903028581581E-15	-1.0780605716316E-14	-1.000000000000	/PANGEM
-.3826834323651	-9.9599809693788E-15	-.9238795325113	/PANGEM
-.7071067811865	-7.6230394073057E-15	-.7071067811865	/PANGEM
-.9238795325113	-4.1255591984946E-15	-.3826834323651	/PANGEM
-1.000000000000	0.	0.	/PANGEM
1.000000000000	-4.1255591984947E-15	-9.9599809693787E-15	/PANGEM
.9238795325113	-.1464466094067	-.3535533905933	/PANGEM
.7071067811865	-.2705980500731	-.6532814824382	/PANGEM
.3826834323651	-.3535533905933	-.8535533905933	/PANGEM
-5.3903028581581E-15	-.3826834323651	-.9238795325113	/PANGEM
-.3826834323651	-.3535533905933	-.8535533905933	/PANGEM
-.7071067811865	-.2705980500731	-.6532814824382	/PANGEM
-.9238795325113	-.1464466094067	-.3535533905933	/PANGEM
-1.000000000000	0.	0.	/PANGEM
1.000000000000	-7.6230394073057E-15	-7.6230394073056E-15	/PANGEM
.9238795325113	-.2705980500731	-.2705980500731	/PANGEM
.7071067811865	-.5000000000000	-.5000000000000	/PANGEM
.3826834323651	-.6532814824382	-.6532814824382	/PANGEM
-5.3903028581581E-15	-.7071067811866	-.7071067811865	/PANGEM
-.3826834323651	-.6532814824382	-.6532814824382	/PANGEM
-.7071067811865	-.5000000000000	-.5000000000000	/PANGEM
-.9238795325113	-.2705980500731	-.2705980500731	/PANGEM
-1.000000000000	0.	0.	/PANGEM

Figure 10.3-2. Continued.

1.000000000000	-9.9599809693788E-15	-4.1255591984945E-15 /PANGEM
.9238795325113	-.3535533905933	-.1464466094067 /PANGEM
.7071067811865	-.6532814824382	-.2705980500731 /PANGEM
.3826834323651	-.8535533905933	-.3535533905933 /PANGEM
-5.3903028581581E-15	-.9238795325113	-.3826834323651 /PANGEM
-.3826834323651	-.8535533905933	-.3535533905933 /PANGEM
-.7071067811865	-.6532814824382	-.2705980500731 /PANGEM
-.9238795325113	-.3535533905933	-.1464466094067 /PANGEM
-1.000000000000	0.	0. /PANGEM
1.000000000000	-1.0780605716316E-14	0. /PANGEM
.9238795325113	-.3826834323651	0. /PANGEM
.7071067811865	-.7071067811866	0. /PANGEM
.3826834323651	-.9238795325113	0. /PANGEM
-5.3903028581581E-15	-1.000000000000	0. /PANGEM
-.3826834323651	-.9238795325113	0. /PANGEM
-.7071067811865	-.7071067811865	0. /PANGEM
-.9238795325113	-.3826834323651	0. /PANGEM
-1.000000000000	0.	0. /PANGEM
1.000000000000	-9.9599809693787E-15	4.1255591984946E-15 /PANGEM
.9238795325113	-.3535533905933	.1464466094067 /PANGEM
.7071067811865	-.6532814824382	.2705980500731 /PANGEM
.3826834323651	-.8535533905933	.3535533905933 /PANGEM
-5.3903028581581E-15	-.9238795325113	.3826834323651 /PANGEM
-.3826834323651	-.8535533905933	.3535533905933 /PANGEM
-.7071067811865	-.6532814824382	.2705980500731 /PANGEM
-.9238795325113	-.3535533905933	.1464466094067 /PANGEM
-1.000000000000	0.	0. /PANGEM
1.000000000000	-7.6230394073056E-15	7.6230394073057E-15 /PANGEM
.9238795325113	-.2705980500731	.2705980500731 /PANGEM
.7071067811865	-.5000000000000	.5000000000000 /PANGEM
.3826834323651	-.6532814824382	.6532814824382 /PANGEM
-5.3903028581581E-15	-.7071067811865	.7071067811865 /PANGEM
-.3826834323651	-.6532814824382	.6532814824382 /PANGEM
-.7071067811865	-.5000000000000	.5000000000000 /PANGEM
-.9238795325113	-.2705980500731	.2705980500731 /PANGEM
-1.000000000000	0.	0. /PANGEM
1.000000000000	-4.1255591984946E-15	9.9599809693788E-15 /PANGEM
.9238795325113	-.1464466094067	.3535533905933 /PANGEM
.7071067811865	-.2705980500731	.6532814824382 /PANGEM
.3826834323651	-.3535533905933	.8535533905933 /PANGEM
-5.3903028581581E-15	-.3826834323651	.9238795325113 /PANGEM
-.3826834323651	-.3535533905933	.8535533905933 /PANGEM
-.7071067811865	-.2705980500731	.6532814824382 /PANGEM
-.9238795325113	-.1464466094067	.3535533905933 /PANGEM
-1.000000000000	0.	0. /PANGEM

Figure 10.3-2. Continued.

1.000000000000	0.	1.0780605716316E-14	/PANGEM
.9238795325113	0.	.3826834323651	/PANGEM
.7071067811865	0.	.7071067811866	/PANGEM
.3826834323651	0.	.9238795325113	/PANGEM
-5.3903028581581E-15	0.	1.000000000000	/PANGEM
-.3826834323651	0.	.9238795325113	/PANGEM
-.7071067811865	0.	.7071067811865	/PANGEM
-.9238795325113	0.	.3826834323651	/PANGEM
-1.000000000000	0.	0.	/PANGEM
TRIANGULAR PANEL TOLERANCE = 1.E-10			/N7
BOUNDARY CONDITION = 1 UPPER			/N9
BEGIN FLOW PROPERTIES DATA			/FP1
FORCES AND MOMENTS			/FM1
AXIS SYSTEMS = RCS			/FM3
SOLUTIONS = 1 2 3 4 5 6			/FM4
CASE = SPHERE-NEAR-WALL			/FM7
LOCAL PRINTOUT = COLSUM NETWORK CONFIGURATION			/FM19
END OF PROBLEM			

Figure 10.3-2. Concluded.

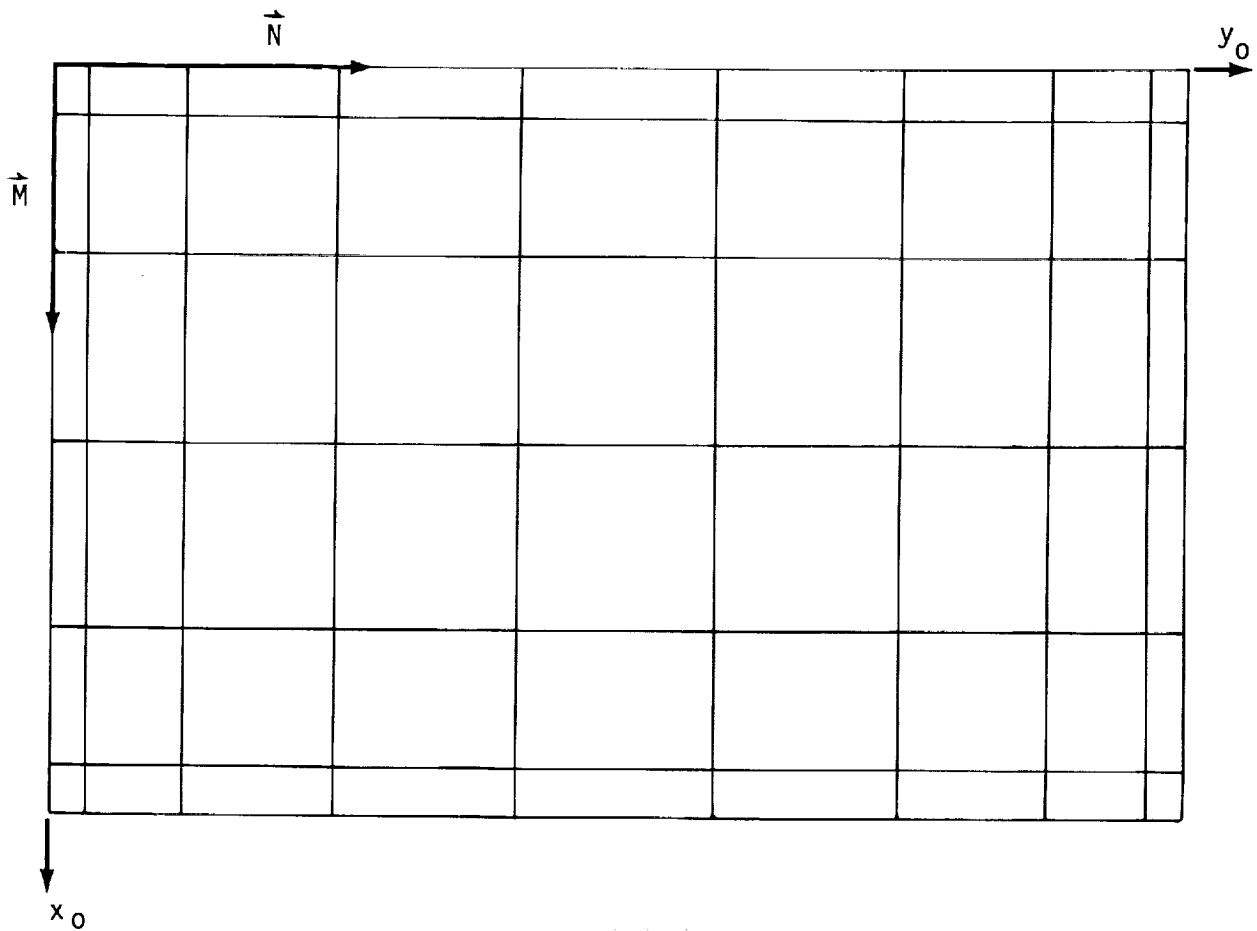

Figure 10.4-1 Rectangular plate panels for the case
 $2a = 1$ and $2b = 1.5$

```

/// GLOBAL DATA GROUP
BEGIN GLOBAL DATA /G1
PID = RECTANGULAR PLATE
UID=R. T. MEDAN, BOEING COMPUTER SERVICES COMPANY, (206) 773 2349
CONFIGURATION = ASYMMETRIC /G4
MACH = 0. /G5
SURFACE SELECTION = AVERAGE /G8
CHECKOUT = ALL /G17
ADDED MASS /G18
/// NETWORK DATA GROUP
BEGIN NETWORK DATA /N1
// START DATA FOR WING NETWORK
/NETWORK = WING = 400
NETWORK=WING 7 10 /N2A
0. 0. 0. /PANGEM
6.6987297958203E-02 0. 0. /PANGEM
.2499999994819 0. 0. /PANGEM
.4999999991026 0. 0. /PANGEM
.7499999989637 0. 0. /PANGEM
.9330127011443 0. 0. /PANGEM
1.000000000000 0. 0. /PANGEM
0. 4.5230534308253E-02 0. /PANGEM
6.6987297958203E-02 4.5230534308253E-02 0. /PANGEM
.2499999994819 4.5230534308253E-02 0. /PANGEM
.4999999991026 4.5230534308253E-02 0. /PANGEM
.7499999989637 4.5230534308253E-02 0. /PANGEM
.9330127011443 4.5230534308253E-02 0. /PANGEM
1.000000000000 4.5230534308253E-02 0. /PANGEM
0. .1754666672762 0. /PANGEM
6.6987297958203E-02 .1754666672762 0. /PANGEM
.2499999994819 .1754666672762 0. /PANGEM
.4999999991026 .1754666672762 0. /PANGEM
.7499999989637 .1754666672762 0. /PANGEM
.9330127011443 .1754666672762 0. /PANGEM
1.000000000000 .1754666672762 0. /PANGEM
0. .3749999992228 0. /PANGEM
6.6987297958203E-02 .3749999992228 0. /PANGEM
.2499999994819 .3749999992228 0. /PANGEM
.4999999991026 .3749999992228 0. /PANGEM
.7499999989637 .3749999992228 0. /PANGEM
.9330127011443 .3749999992228 0. /PANGEM
1.000000000000 .3749999992228 0. /PANGEM

```

Figure 10.4-2. DIP input for the rectangular plate with
 $2a = 1$ and $2b = 1.5$

0.	.6197638655714	0.	/PANGEM
6.6987297958203E-02	.6197638655714	0.	/PANGEM
.2499999994819	.6197638655714	0.	/PANGEM
.4999999991026	.6197638655714	0.	/PANGEM
.7499999989637	.6197638655714	0.	/PANGEM
.9330127011443	.6197638655714	0.	/PANGEM
1.000000000000	.6197638655714	0.	/PANGEM
0.	.8802361317772	0.	/PANGEM
6.6987297958203E-02	.8802361317772	0.	/PANGEM
.2499999994819	.8802361317772	0.	/PANGEM
.4999999991026	.8802361317772	0.	/PANGEM
.7499999989637	.8802361317772	0.	/PANGEM
.9330127011443	.8802361317772	0.	/PANGEM
1.000000000000	.8802361317772	0.	/PANGEM
0.	1.124999998446	0.	/PANGEM
6.6987297958203E-02	1.124999998446	0.	/PANGEM
.2499999994819	1.124999998446	0.	/PANGEM
.4999999991026	1.124999998446	0.	/PANGEM
.7499999989637	1.124999998446	0.	/PANGEM
.9330127011443	1.124999998446	0.	/PANGEM
1.000000000000	1.124999998446	0.	/PANGEM
0.	1.324533330993	0.	/PANGEM
6.6987297958203E-02	1.324533330993	0.	/PANGEM
.2499999994819	1.324533330993	0.	/PANGEM
.4999999991026	1.324533330993	0.	/PANGEM
.7499999989637	1.324533330993	0.	/PANGEM
.9330127011443	1.324533330993	0.	/PANGEM
1.000000000000	1.324533330993	0.	/PANGEM
0.	1.454769464771	0.	/PANGEM
6.6987297958203E-02	1.454769464771	0.	/PANGEM
.2499999994819	1.454769464771	0.	/PANGEM
.4999999991026	1.454769464771	0.	/PANGEM
.7499999989637	1.454769464771	0.	/PANGEM
.9330127011443	1.454769464771	0.	/PANGEM
1.000000000000	1.454769464771	0.	/PANGEM
0.	1.500000000000	0.	/PANGEM
6.6987297958203E-02	1.500000000000	0.	/PANGEM
.2499999994819	1.500000000000	0.	/PANGEM
.4999999991026	1.500000000000	0.	/PANGEM
.7499999989637	1.500000000000	0.	/PANGEM
.9330127011443	1.500000000000	0.	/PANGEM
1.000000000000	1.500000000000	0.	/PANGEM

BOUNDARY CONDITION = 1, 3 /N9

Figure 10.4-2. Continued.

```
/// FLOW PROPERTIES DATA GROUP
BEGIN FLOW PROPERTIES DATA /FP1
// NO PDP CASES
FORCES AND MOMENTS /FM1
AXIS SYSTEM = RCS /FM3
PRINTOUT = PANELS, COLSUM, NETWORKS, CONFIGURATION /FM5
CASE = RECTANGULAR-PLATE /FM7
NETWORKS-IMAGES=1 INPUT /FM8
END PROBLEM DEFINITION
```

Figure 10.4-2. Concluded.

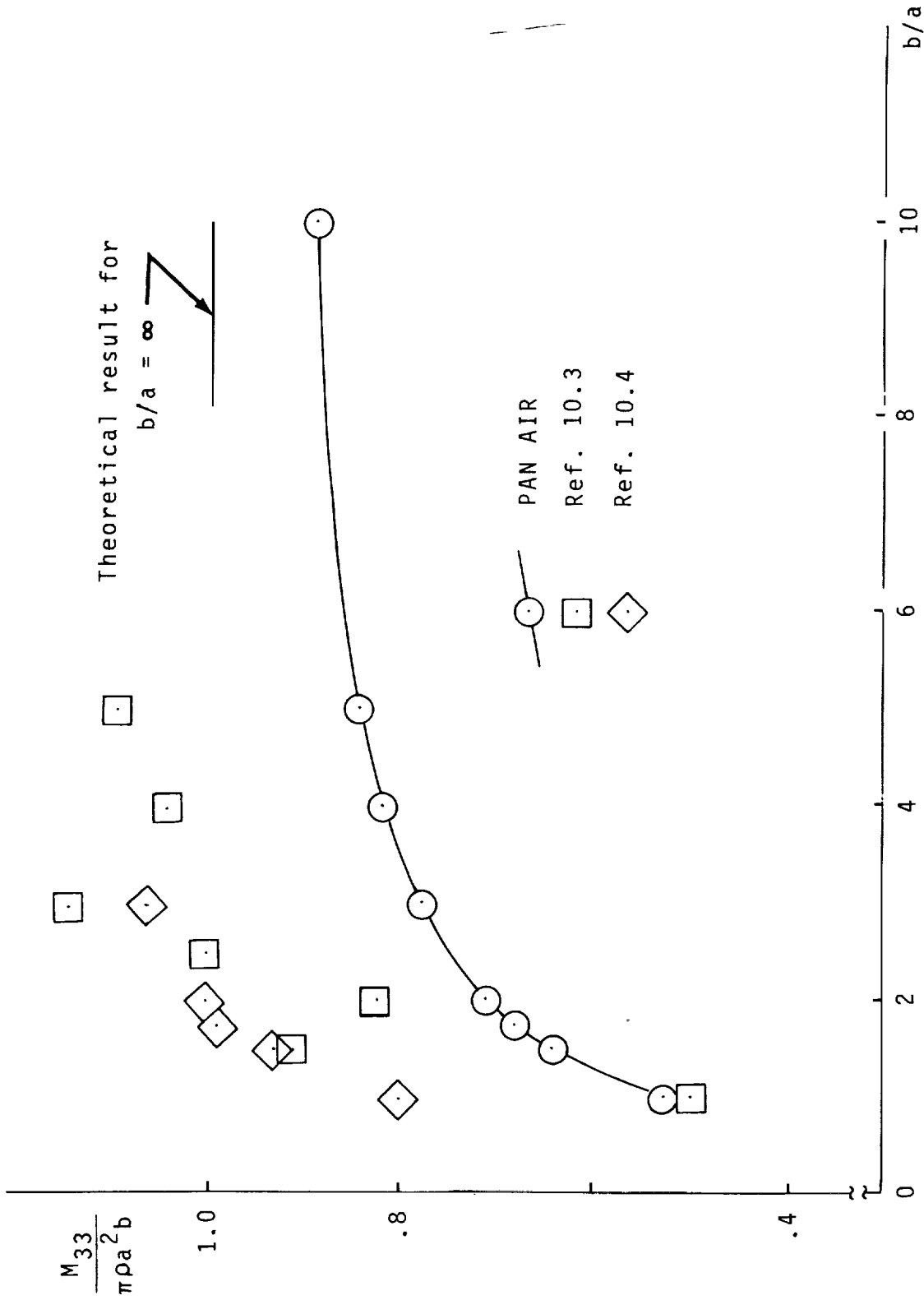

Figure 10.4-3. Comparison of PAN AIR added mass coefficients with experimental added mass coefficients for thin rectangular plates.

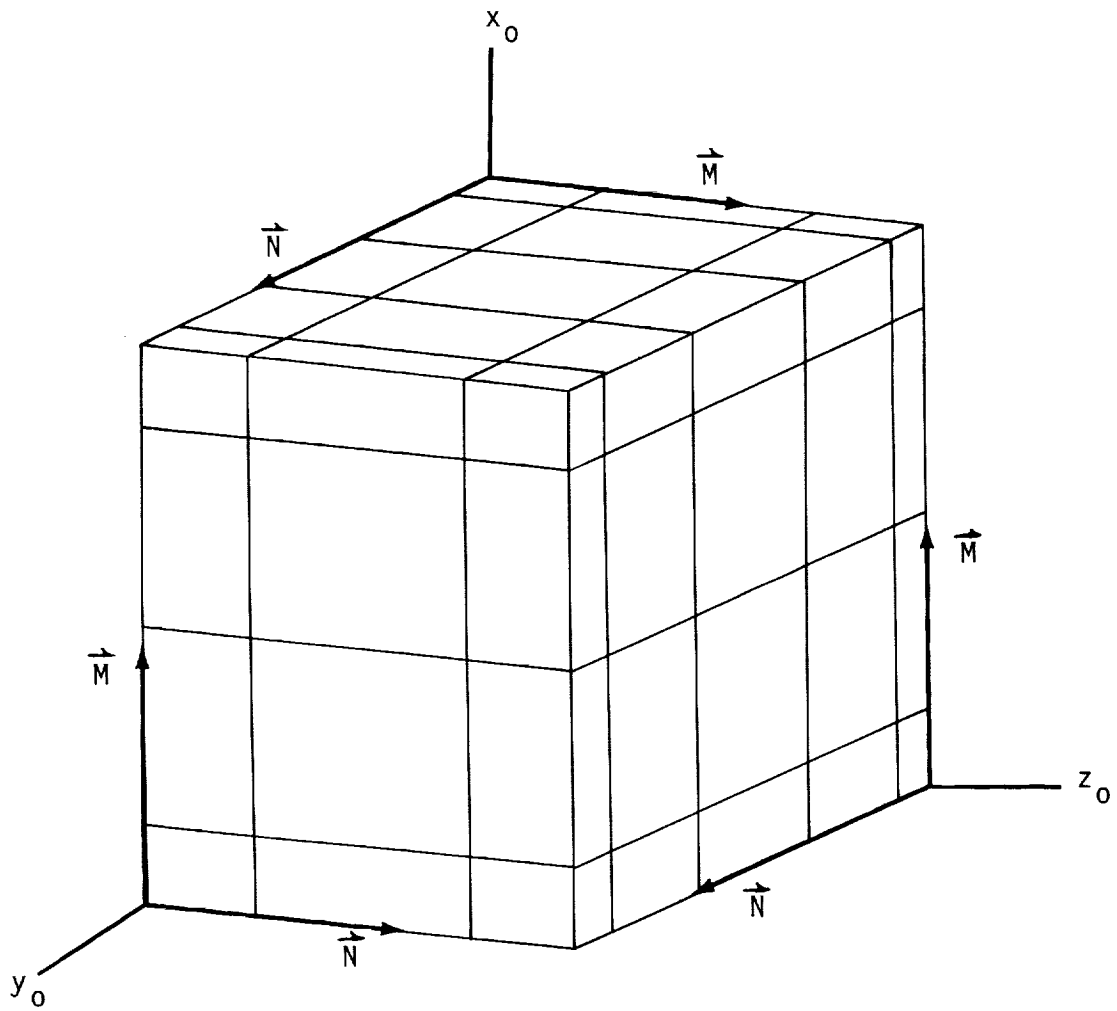

Figure 10.5-1. Example of panels for the parallelepiped with $a = 3$, $b = 4$, and $c = 2.5$.

```

BEGIN GLOBAL /G1
PID = PARALLELEPIPED
UID = R.T.MEDAN
CONFIGURATION = ASYMMETRIC /G4
MACH = 0. /G5
SURFACE = UPPER /G8
TOLERANCE = 1.E-10 /G7
CHECKOUT = DIP , 1 2 3 , DQG , 1 2 4 5 /G17
ADDED MASS /G18
BEGIN NETWORK DATA /N1
/NETWORK = Z.EQ.O-FACE = 500
NETWORK=Z.EQ.O-FACE 5 6 /N2A
0. 0. 0. /PANGEM
.8786796545366 0. 0. /PANGEM
2.999999994615 0. 0. /PANGEM
5.121320337848 0. 0. /PANGEM
6.000000000000 0. 0. /PANGEM
0. .7639320208122 0. /PANGEM
.8786796545366 .7639320208122 0. /PANGEM
2.999999994615 .7639320208122 0. /PANGEM**
5.121320337848 .7639320208122 0. /PANGEM^
6.000000000000 .7639320208122 0. /PANGEM
0. 2.763932017038 0. /PANGEM
.8786796545366 2.763932017038 0. /PANGEM
2.999999994615 2.763932017038 0. /PANGEM
5.121320337848 2.763932017038 0. /PANGEM
6.000000000000 2.763932017038 0. /PANGEM
0. 5.236067969306 0. /PANGEM
.8786796545366 5.236067969306 0. /PANGEM
2.999999994615 5.236067969306 0. /PANGEM
5.121320337848 5.236067969306 0. /PANGEM
6.000000000000 5.236067969306 0. /PANGEM
0. 7.236067970748 0. /PANGEM
.8786796545366 7.236067970748 0. /PANGEM
2.999999994615 7.236067970748 0. /PANGEM
5.121320337848 7.236067970748 0. /PANGEM
6.000000000000 7.236067970748 0. /PANGEM
0. 8.000000000000 0. /PANGEM
.8786796545366 8.000000000000 0. /PANGEM
2.999999994615 8.000000000000 0. /PANGEM
5.121320337848 8.000000000000 0. /PANGEM
6.000000000000 8.000000000000 0. /PANGEM
BOUNDARY CONDITION = 1,UPPER /N9

```

Figure 10.5-2. DIP input for the parallelepiped with
a = 3, b = 4, and c = 2.5.

```

/NETWORK = Z.EQ.2C-FACE = 501
NETWORK=Z.EQ.2C-FACE          5    6
0.                             0.    5.000000000000 /N2A /PANGEM
.8786796545366                0.    5.000000000000 /PANGEM
2.999999994615                0.    5.000000000000 /PANGEM
5.121320337848                0.    5.000000000000 /PANGEM
6.000000000000                0.    5.000000000000 /PANGEM
0.                             .7639320208122 5.000000000000 /PANGEM
.8786796545366                .7639320208122 5.000000000000 /PANGEM
2.999999994615                .7639320208122 5.000000000000 /PANGEM
5.121320337848                .7639320208122 5.000000000000 /PANGEM
6.000000000000                .7639320208122 5.000000000000 /PANGEM
0.                             2.763932017038 5.000000000000 /PANGEM
.8786796545366                2.763932017038 5.000000000000 /PANGEM
2.999999994615                2.763932017038 5.000000000000 /PANGEM
5.121320337848                2.763932017038 5.000000000000 /PANGEM
6.000000000000                2.763932017038 5.000000000000 /PANGEM
0.                             5.236067969306 5.000000000000 /PANGEM
.8786796545366                5.236067969306 5.000000000000 /PANGEM
2.999999994615                5.236067969306 5.000000000000 /PANGEM
5.121320337848                5.236067969306 5.000000000000 /PANGEM
6.000000000000                5.236067969306 5.000000000000 /PANGEM
0.                             7.236067970748 5.000000000000 /PANGEM
.8786796545366                7.236067970748 5.000000000000 /PANGEM
2.999999994615                7.236067970748 5.000000000000 /PANGEM
5.121320337848                7.236067970748 5.000000000000 /PANGEM
6.000000000000                7.236067970748 5.000000000000 /PANGEM
0.                             8.000000000000 5.000000000000 /PANGEM
.8786796545366                8.000000000000 5.000000000000 /PANGEM
2.999999994615                8.000000000000 5.000000000000 /PANGEM
5.121320337848                8.000000000000 5.000000000000 /PANGEM
6.000000000000                8.000000000000 5.000000000000 /PANGEM
BOUNDARY CONDITION = 1,LOWER /N9

```

Figure 10.5-2. Continued.

```

/NETWORK = Y.EQ.0-FACE = 502
NETWORK=Y.EQ.0-FACE      5      4
0.      0.      0.      /N2A
      .8786796545366      0.      0.      /PANGEM
      2.999999994615      0.      0.      /PANGEM
      5.121320337848      0.      0.      /PANGEM
      6.000000000000      0.      0.      /PANGEM
0.      0.      1.249999997409      /PANGEM
      .8786796545366      0.      1.249999997409      /PANGEM
      2.999999994615      0.      1.249999997409      /PANGEM
      5.121320337848      0.      1.249999997409      /PANGEM
      6.000000000000      0.      1.249999997409      /PANGEM
0.      0.      3.749999994819      /PANGEM
      .8786796545366      0.      3.749999994819      /PANGEM
      2.999999994615      0.      3.749999994819      /PANGEM
      5.121320337848      0.      3.749999994819      /PANGEM
      6.000000000000      0.      3.749999994819      /PANGEM
0.      0.      5.000000000000      /PANGEM
      .8786796545366      0.      5.000000000000      /PANGEM
      2.999999994615      0.      5.000000000000      /PANGEM
      5.121320337848      0.      5.000000000000      /PANGEM
      6.000000000000      0.      5.000000000000      /PANGEM
BOUNDARY CONDITION = 1,LOWER      /N9
/NETWORK = Y.EQ.2B-FACE = 503
NETWORK=Y.EQ.2B-FACE      5      4
0.      8.000000000000      0.      /N2A
      .8786796545366      8.000000000000      0.      /PANGEM
      2.999999994615      8.000000000000      0.      /PANGEM
      5.121320337848      8.000000000000      0.      /PANGEM
      6.000000000000      8.000000000000      0.      /PANGEM
0.      8.000000000000      1.249999997409      /PANGEM
      .8786796545366      8.000000000000      1.249999997409      /PANGEM
      2.999999994615      8.000000000000      1.249999997409      /PANGEM
      5.121320337848      8.000000000000      1.249999997409      /PANGEM
      6.000000000000      8.000000000000      1.249999997409      /PANGEM
0.      8.000000000000      3.749999994819      /PANGEM
      .8786796545366      8.000000000000      3.749999994819      /PANGEM
      2.999999994615      8.000000000000      3.749999994819      /PANGEM
      5.121320337848      8.000000000000      3.749999994819      /PANGEM
      6.000000000000      8.000000000000      3.749999994819      /PANGEM
0.      8.000000000000      5.000000000000      /PANGEM
      .8786796545366      8.000000000000      5.000000000000      /PANGEM
      2.999999994615      8.000000000000      5.000000000000      /PANGEM
      5.121320337848      8.000000000000      5.000000000000      /PANGEM
      6.000000000000      8.000000000000      5.000000000000      /PANGEM
BOUNDARY CONDITION = 1,UPPER      /N9

```

Figure 10.5-2. Continued.

/NETWORK = X.EQ.O-FACE = 504

NETWORK=X.EQ.O-FACE

	4	6		/N2A
0.	0.		0.	/PANGEM
0.	0.		1.249999997409	/PANGEM
0.	0.		3.749999994819	/PANGEM
0.	0.		5.000000000000	/PANGEM
0.	.7639320208122		0.	/PANGEM
0.	.7639320208122		1.249999997409	/PANGEM
0.	.7639320208122		3.749999994819	/PANGEM
0.	.7639320208122		5.000000000000	/PANGEM
0.	2.763932017038		0.	/PANGEM
0.	2.763932017038		1.249999997409	/PANGEM
0.	2.763932017038		3.749999994819	/PANGEM
0.	2.763932017038		5.000000000000	/PANGEM
0.	5.236067969306		0.	/PANGEM
0.	5.236067969306		1.249999997409	/PANGEM
0.	5.236067969306		3.749999994819	/PANGEM
0.	5.236067969306		5.000000000000	/PANGEM
0.	7.236067970748		0.	/PANGEM
0.	7.236067970748		1.249999997409	/PANGEM
0.	7.236067970748		3.749999994819	/PANGEM
0.	7.236067970748		5.000000000000	/PANGEM
0.	8.000000000000		0.	/PANGEM
0.	8.000000000000		1.249999997409	/PANGEM
0.	8.000000000000		3.749999994819	/PANGEM
0.	8.000000000000		5.000000000000	/PANGEM

BOUNDARY CONDITION = 1,LOWER

/N9

Figure 10.5-2. Continued.

```

/NETWORK = X.EQ.2A-FACE = 505
NETWORK=X.EQ.2A-FACE      4      6
  6.000000000000      0.      0.      0.      /N2A
  6.000000000000      0.      1.249999997409      /PANGEM
  6.000000000000      0.      3.749999994819      /PANGEM
  6.000000000000      0.      5.000000000000      /PANGEM
  6.000000000000      .7639320208122      0.      /PANGEM
  6.000000000000      .7639320208122      1.249999997409      /PANGEM
  6.000000000000      .7639320208122      3.749999994819      /PANGEM
  6.000000000000      .7639320208122      5.000000000000      /PANGEM
  6.000000000000      2.763932017038      0.      /PANGEM
  6.000000000000      2.763932017038      1.249999997409      /PANGEM
  6.000000000000      2.763932017038      3.749999994819      /PANGEM
  6.000000000000      2.763932017038      5.000000000000      /PANGEM
  6.000000000000      5.236067969306      0.      /PANGEM
  6.000000000000      5.236067969306      1.249999997409      /PANGEM
  6.000000000000      5.236067969306      3.749999994819      /PANGEM
  6.000000000000      5.236067969306      5.000000000000      /PANGEM
  6.000000000000      7.236067970748      0.      /PANGEM
  6.000000000000      7.236067970748      1.249999997409      /PANGEM
  6.000000000000      7.236067970748      3.749999994819      /PANGEM
  6.000000000000      7.236067970748      5.000000000000      /PANGEM
  6.000000000000      8.000000000000      0.      /PANGEM
  6.000000000000      8.000000000000      1.249999997409      /PANGEM
  6.000000000000      8.000000000000      3.749999994819      /PANGEM
  6.000000000000      8.000000000000      5.000000000000      /PANGEM
BOUNDARY CONDITION = 1,UPPER      /N9
BEGIN FLOW PROPERTIES      /FP1
FORCES AND MOMENTS      /FM1
AXIS SYSTEM = RCS      /FM3
CASE = PARALLELEPIPED      /FM7
NETWORKS = 1 , RETAIN +
          = 2 , REVERSE +
          = 3 , REVERSE +
          = 4 , RETAIN +
          = 5 , REVERSE +
          = 6 , RETAIN
LOCAL PRINTOUT = COLSUM NETWORKS CONFIGURATION      /FM8
END      /FM19

```

Figure 10.5-2. Concluded.



Small vertical text or markings on the left edge, possibly a page number or reference code.



1

2

3

4

5

