

## GAS FLOW ENVIRONMENT AND HEAT TRANSFER

## NONROTATING 3D PROGRAM

Roy J. Schulz  
The University of Tennessee Space Institute  
Tullahoma, Tennessee

## OBJECTIVES

The experimental contract objective is to provide a complete set of "benchmark" quality data for the flow and heat transfer within a large rectangular turning duct. These data are to be used to evaluate, and verify, three-dimensional internal viscous flow models and computational codes. The analytical contract objective is to select such a computational code and define the capabilities of this code to predict the experimental results obtained experimentally. Details of the proper code operation will be defined and improvements to the code modeling capabilities will be formulated.

The experimental and analytical efforts are being conducted under a coordinated multiphase contract. Phase one, the current work, is the study of internal flow in a large rectangular cross-sectioned, 90° bend turning duct, and is planned as a 28 month study which started in April, 1982. Phase one is divided into five tasks, numbered I through V. Future work to be performed at NASA's option includes the investigation of flow over an airfoil cascade, with and without film cooling, inside the turning radius of the duct. This future work is designated as phases two and three of the contract. Phase two, consisting of Tasks VI through XI, will consider a large scale cascade where "benchmark" data will be obtained to document the viscous flow field, pressure distribution and heat transfer phenomenon. Phase three of the contract, consisting of Tasks XII through XVI, includes mass flow injection from cascaded airfoils to document the flow field and heat transfer with film cooling of the blades.

## APPROACH

Separate experimental and analytical approaches have been undertaken to attain the contract objectives. The experimental approach for Phase 1, the current work, initiated with design, fabrication, and instrumentation of a large rectangular turning duct with a 90° bend. Air flow will be drawn through the duct using an induced draft fan with variable blade pitch and variable rotation speed, to provide both a range of flow conditions in the duct and controllability for maintaining constant conditions during testing. The duct has been designed to be assembled in modules, allowing simple modifications of the duct for varying the inlet length or the wall boundary layer conditions. The duct construction is designed to allow detailed measurements to be made for the following three duct wall conditions: 1) an isothermal wall with isothermal flow, 2) an adiabatic wall with convective heat transfer by mixing between unheated surrounding flow, and 3) an isothermal wall with heat transfer from a uniformly hot inlet flow. Measurements for all three conditions will be made at two bulk Reynolds numbers and different inlet lengths to provide both laminar and fully turbulent boundary layer flows approaching the duct turn. The flow velocities for both Reynolds numbers will be low enough to remain well within the incompressible Mach number range so that only thermally induced density gradients will be encountered.

The primary instrumentation being assembled for the flow measurements is a three-dimensional, vector laser velocimeter (LV). The LV will use two colors and Bragg diffraction beam splitting/frequency shifting to separate the three simultaneous, orthogonal, vector velocity components. The LV signal processors determine digital values of velocity for the seeded flows from particle crossing the laser beam generated probe volume. To simplify and speed up digital data acquisition, the LV processors are built around an S-100 bus Z-80 microprocessor, which provides the additional advantage of on-line, near-real time data reduction. This on-line data reduction capability will be used to assess the adequacy and precision of the data as it is acquired and recorded for more complex, off-line detailed analysis. To help qualify the measurements as "benchmark" data, the LV measurements will be compared with both pitot probe and hot wire anemometer measurements for flow conditions which permit these comparisons.

The analytical approach initiated with a search for candidate state-of-the-art numerical solution procedures for internal, three-dimensional viscous flows. The two candidate codes selected were the P. D. Thomas Beam-Warming code and the Briley-McDonald "MINT" code. With both codes and their available documentation obtained, a comparison of them will be made in terms of user orientation, documentation, numerics, physical modeling, accuracy, grid sensitivity, boundary conditions, formulation, CPU time and ease of extension to future problems. Initial results will be obtained for calibration purposes and compared to published results, and with flows visualized and measured with a 2-D LV system in a 1/3 scale duct. Then numerical convergence properties and grid refinement techniques will be studied, both by uniform refinement and by local clustering of the mesh points. After the effects of discretization error have been estimated the code predictions will be compared with full scale experimental data as it is obtained, for laminar flow and turbulent flow to evaluate available turbulence models. Finally, heat transfer modeling will be evaluated, and the best of the codes selected for a detailed comparison with the experimental data. This detailed comparison will determine the accuracy of the code's calculated flow field and generate recommendations and formulations for code improvement.

#### CURRENT RESULTS AND PLANS

Both the experimental and analytical phases are currently underway. The experimental phase has involved test facility and instrumentation design and fabrication. The turning duct design has been approved by NASA program monitors and is essentially an induced draft wind tunnel with a 90° bend test section. Nominal bulk flow velocities of 6.096 m/sec (20 ft/sec) and 60.96 m/sec (200 ft/sec) and different straight inlet lengths were selected for the low and high Reynolds number cases to provide moderately thick laminar and turbulent boundary layers entering the bend. The contour of the inlet transition, or bellmouth, was designed by numerical calculations to provide smooth acceleration to the inlet section. The flow rates corresponding to the selected velocity were used to specify an induced draft fan for the duct exit, which in turn, established the diffuser configuration. The 90° curve section of the duct will be assembled from a series of flanged interchangeable modules. Additionally, interchangeable instrument access modules provide access for probing the flow with the LV and with the pitot and hot wire probes. The duct will

be insulated for the adiabatic wall test cases, and water jackets will be added to establish the isothermal wall test cases. The LV window module allows optical access from all four walls of the duct, with an unobstructed field of view so that the LV probe volume can be traversed from wall to wall. The window segments are thin, optical flats which are only 1.27 cm (1/2 in) wide along the inside wall. The windows were designed to minimize deviations from wall curvature on the convex and concave duct sidewalls. This test facility is presently in the materials acquisition and mechanical fabrication stage.

The LV optical assembly will be mounted on a box beam structure which fits around the duct. The LV scans the duct cross-plane and cross-stream coordinate directions by activating an LV microprocessor-controlled mill bed, to which the box beam is mounted. The optical arrangement allows the three pairs of laser beams to cross coincident within  $\pm 0.5$  mm, as well as forward scatter light collection for greatest signal to noise ratio. The signal to noise ratio and processor accuracy are also improved by mixing the collected signals with accurately known oscillators that downbeat the signals to lower frequencies. The reduced signal frequencies eliminate the effects of small deviations centered on very high RF carrier frequencies from affecting the measurements. Hardware is being acquired and software is being developed for improved on-line graphics for data reduction and presentation which allows assessment of the validity and precision of the LV measurements as they are being acquired. This significantly improves the established levels of statistical confidence and also helps assure that all critical physical flow features are being measured. LV system development is moving into the shakedown stage, which is being initiated by evaluating the flow in a 1/3 scale model duct. An evaluation of LV compatibility with the windowed optical access module is also planned before LV and intrusive probe comparison testing is initiated.

The analytical effort is also well underway. One of the selected computational codes, the P. D. Thomas code, was received for evaluation, and requests have been made for a recent version of the Briley-McDonald "MINT" code. The P. D. Thomas code has extensive documentation and has been adapted to the experimental geometry of the 90° bend duct. Numerically converged results have been obtained for a published, laminar flow case. Also, the initial results were compared to published solutions of the "MINT" code for the same flow, which includes duct geometry and Reynolds number, although the flow inlet Mach number used for the Thomas code was greater. With either computer code discrepancies between computed solutions and experimental measurements for both laminar and turbulent flows have been reported. The source of the discrepancy seems to be discretization error, and derive a set of approximate solution errors. Also, solutions of both codes will be compared with flow visualization in a 1/3 scale duct, to help identify problem areas with both code results.



**GAS FLOW ENVIRONMENT AND HEAT TRANSFER -  
NONROTATING 3D PROGRAM**

NASA CONTRACT NAS3-23278

Roy J. Schulz, Ph.D., P.E.

**OBJECTIVES**

- PROVIDE "BENCHMARK" DATA DELINEATING 3-D VISCOUS FLOW WITH HEAT TRANSFER ON A LARGE, RECTANGULAR, 90° BEND TURNING DUCT

PHASE

1. FLOW DEVELOPMENT IN THE BEND WITH DIFFERENT INLET BOUNDARY LAYERS AND WALL HEAT FLUX DISTRIBUTIONS (TASK I-V)
  2. FLOW DEVELOPMENT IN THE BEND WITH AN IMBEDDED CASCADE BLADE SYSTEM FOR DIFFERENT INLET BOUNDARY LAYERS AND WALL HEAT FLUX DISTRIBUTION (TASKS VI-XI)
  3. FLOW DEVELOPMENT IN THE BEND WITH AN IMBEDDED CASCADE BLADE SYSTEM USING AIR INJECTED THROUGH THE BLADES TO SIMULATE FILM COOLING FOR DIFFERENT INLET BOUNDARY LAYERS AND WALL HEAT FLUX DISTRIBUTIONS (TASK XII - XVI)
- SELECT, EVALUATE, MODIFY AND/OR DEVELOP A STATE-OF-THE-ART 3-D VISCOUS FLOW COMPUTER CODE BY CONFRONTATION WITH EXPERIMENTAL DATA (SAME 3 PHASES)
    - VALIDATE CODES' CAPABILITY/ADAPTABILITY
    - ADD, IF NECESSARY, ENERGY TRANSFER/CONSERVATION EQUATION
    - EVALUATE TURBULENT TRANSPORT MODELS FOR THIS CLASS OF FLOWS
    - DEFINE MESH ESTABLISHMENT AND RESOLUTION REQUIRED FOR ACCURATE COMPUTATION OF THIS CLASS OF FLOWS.

## EXPERIMENTAL APPROACH

- BUILD FACILITY AND INSTRUMENTATION
  - MODIFIABLE CURVED DUCT
    - VARIABLE AIR FLOW
    - SEGMENTED CONSTRUCTION
  - LASER VELOCIMETER INSTRUMENTATION
    - SIMULTANEOUS 3 COMPONENT DETERMINATION
    - BRAGG SYSTEM (VELOCITY VECTOR MEASUREMENTS)
    - MICROPROCESSOR BASED SYSTEM - OUTLINE STATISTICAL DATA DETERMINATION
    - VALIDATED AGAINST PITOT AND HOT WIRE SYSTEM
- DUCT EXPERIMENTS - TO FACILITATE ANALYTICAL COMPARISONS
  - UNHEATED FLOW - 2 ENTRANCE CONDITIONS
  - MIXING OF HOT AND COLD STREAMS WITH ADIABATIC WALL
  - HOT FLOW WITH ISOTHERMAL WALL
- CASCADE EXPERIMENT - BLADES INSTALLED IN DUCT BEND
  - SAME SERIES AS DUCT EXPERIMENTS
  - REPEAT SERIES WITH SIMULATED FILM COOLING

## ANALYTICAL APPROACH

- COMPARE APPLICABLE 3-D CODES WITH ADEQUATE DOCUMENTATION
  - LAMINAR FLOW CALCULATIONS WITHOUT HEAT TRANSFER
    - ADAPT CODE TO PROBLEM - BOUNDARY AND INITIAL CONDITIONS
    - COMPARE WITH FLOW VISUALIZATION RESULTS
    - COMPARE WITH PUBLISHED RESULTS FOR SIMILAR CONFIGURATIONS
- PRELIMINARY COMPARISON WITH DATA (INCLUDING TURBULENT FLOW AND HEAT TRANSFER), AS IT IS OBTAINED
  - COMPARE CODES FOR RESOLUTION WITH EQUIVALENT GRIDS, COMPUTATIONAL TIME, STORAGE, EASE OF IMPLEMENTATION AND EASE OF MODIFICATION
  - SELECT CODE FOR DETAILED COMPARISON WITH DATA
- DETAILED COMPARISONS WITH DATA
  - FORMULATE IMPROVEMENTS
  - EVALUATE SENSITIVITY TO GRID SPACING AND TIME STEP SELECTION

SCHEDULE

Phase 1

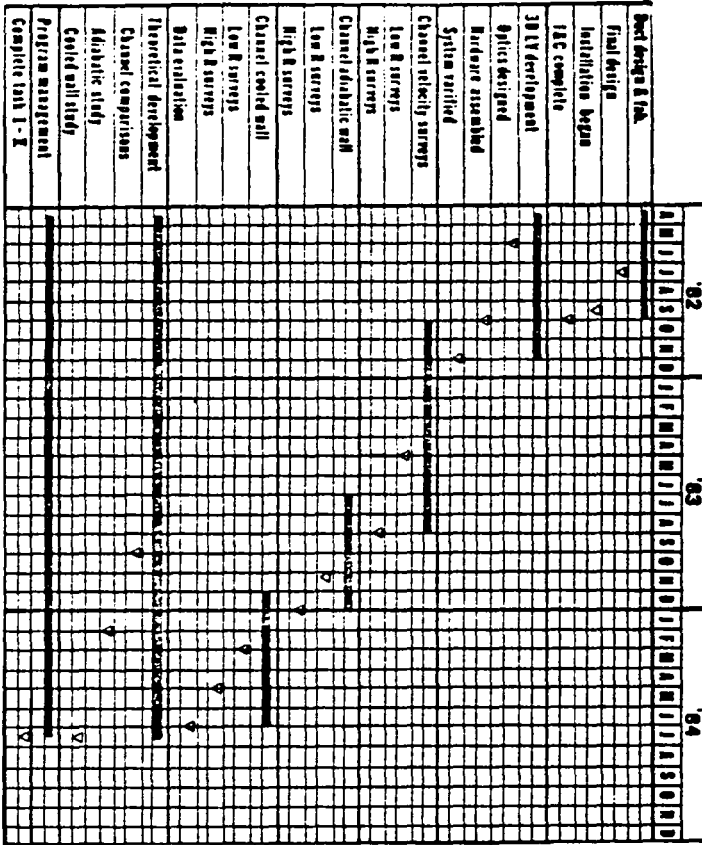

90° BEND TURNING DUCT

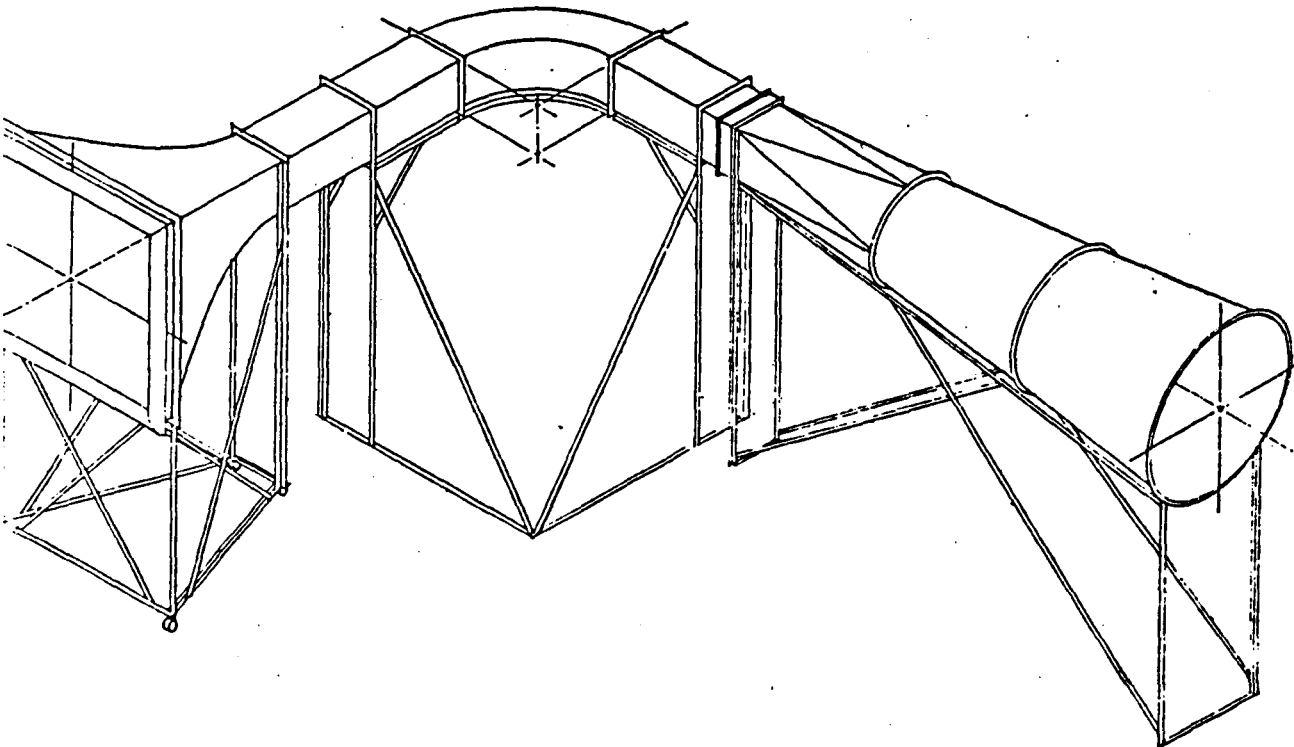

10

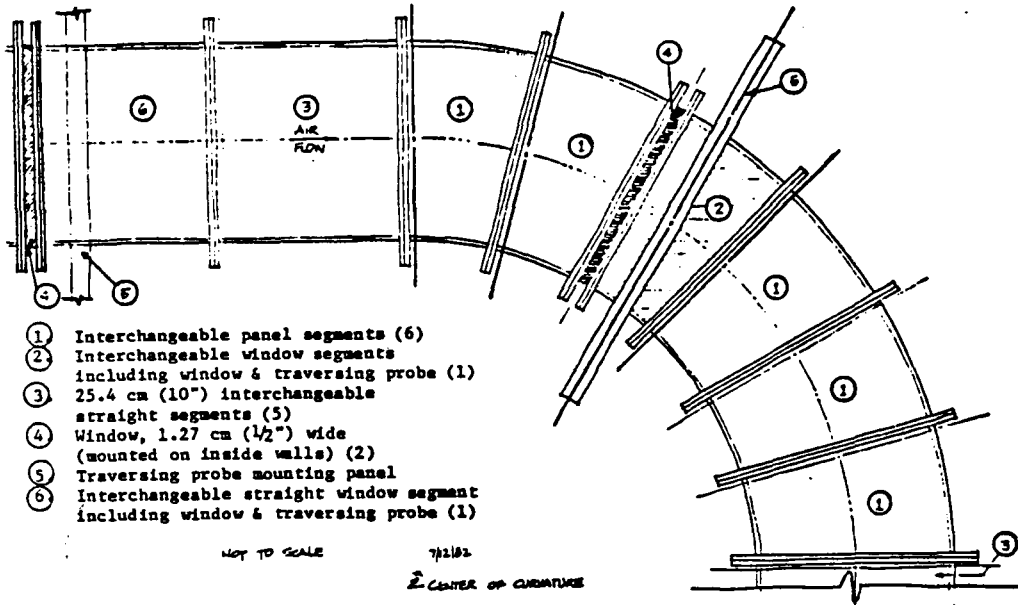

- ① Interchangeable panel segments (6)
- ② Interchangeable window segments including window & traversing probe (1)
- ③ 25.4 cm (10") interchangeable straight segments (5)
- ④ Window, 1.27 cm (1/2") wide (mounted on inside walls) (2)
- ⑤ Traversing probe mounting panel
- ⑥ Interchangeable straight window segment including window & traversing probe (1)

NOT TO SCALE  
 7/2/82  
 CENTER OF CURVATURE

SEGMENTATION OF BEND

11

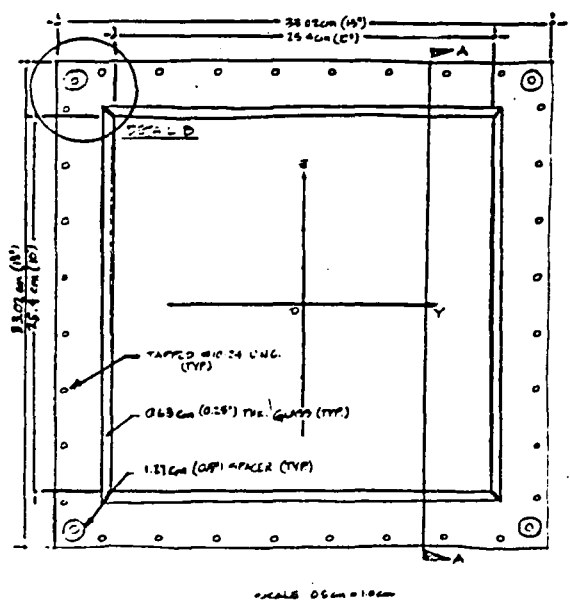

SCALE 0.6cm = 1.0cm

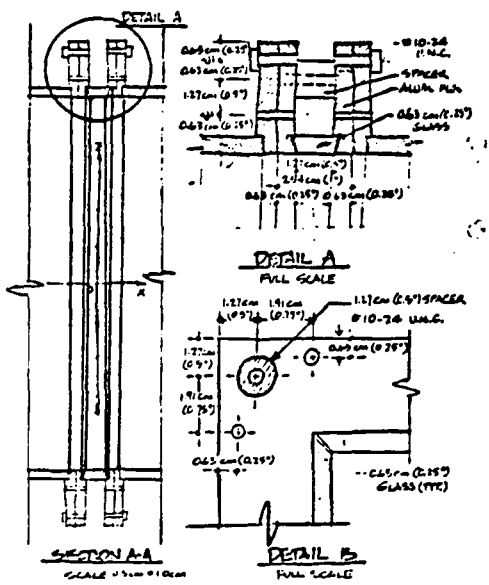

WINDOW MODULE

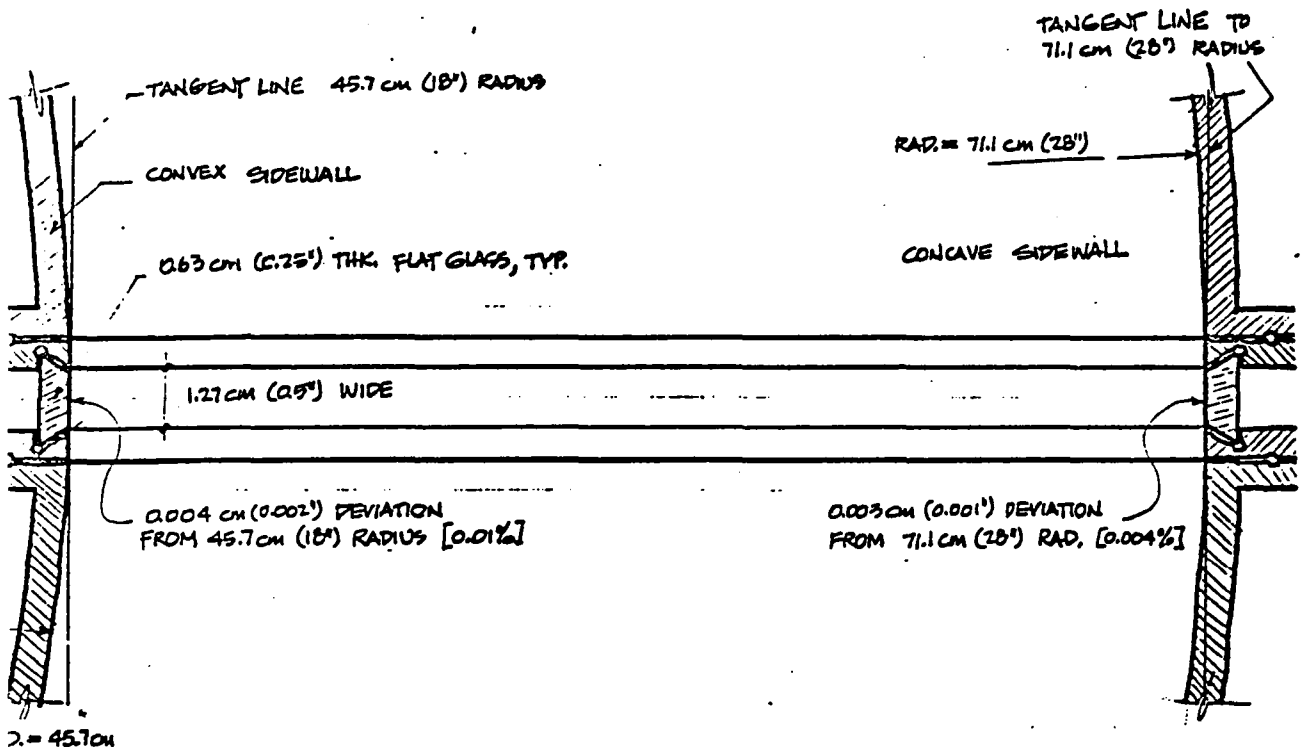

FLAT WINDOW INSTALLATION

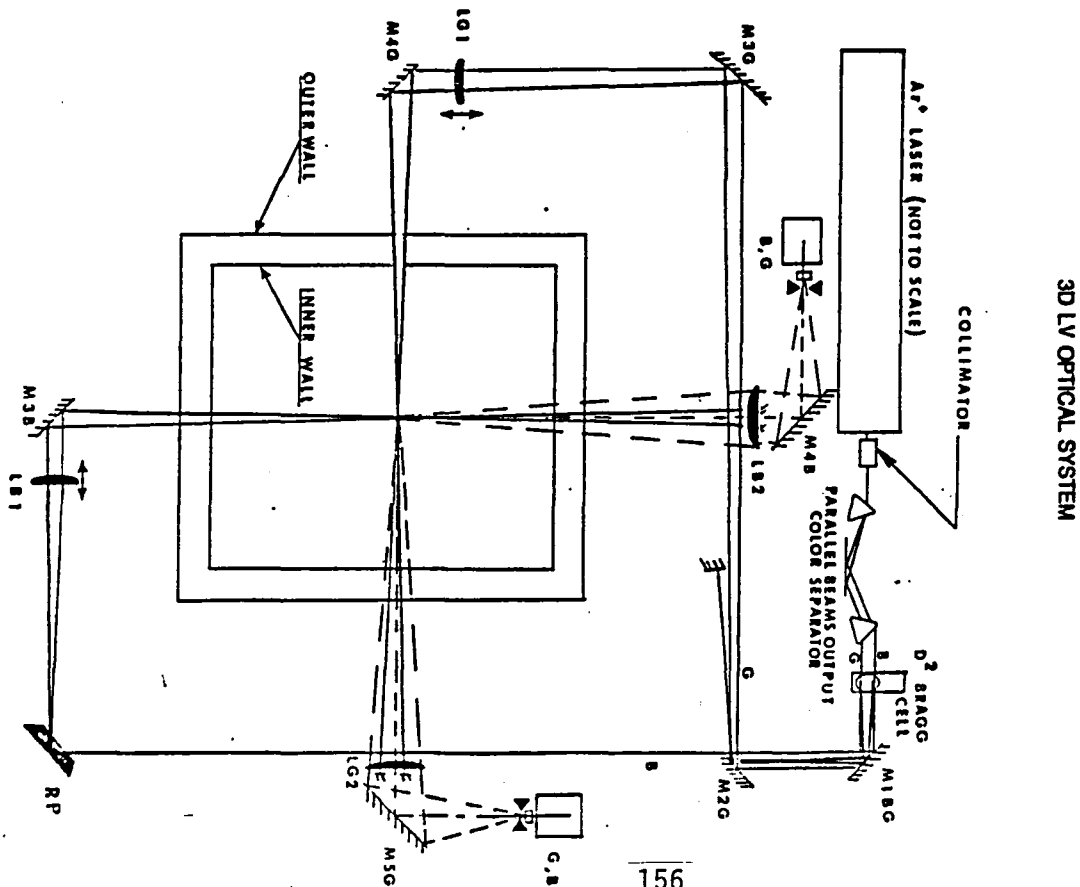



VELOCITY PLOT FOR TH=75.00 TIME STEP=240

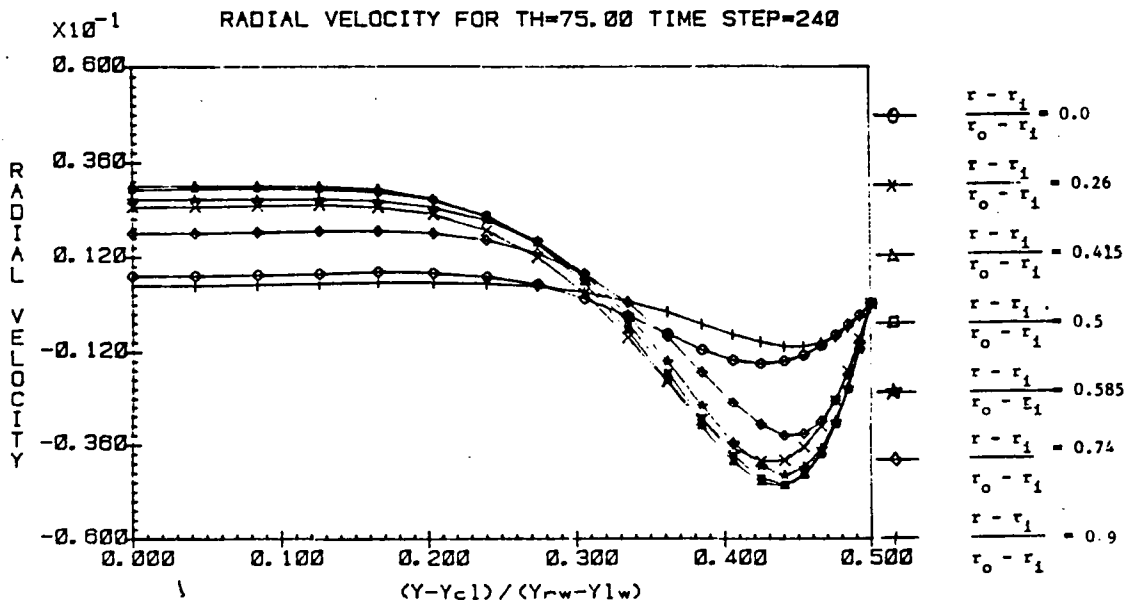
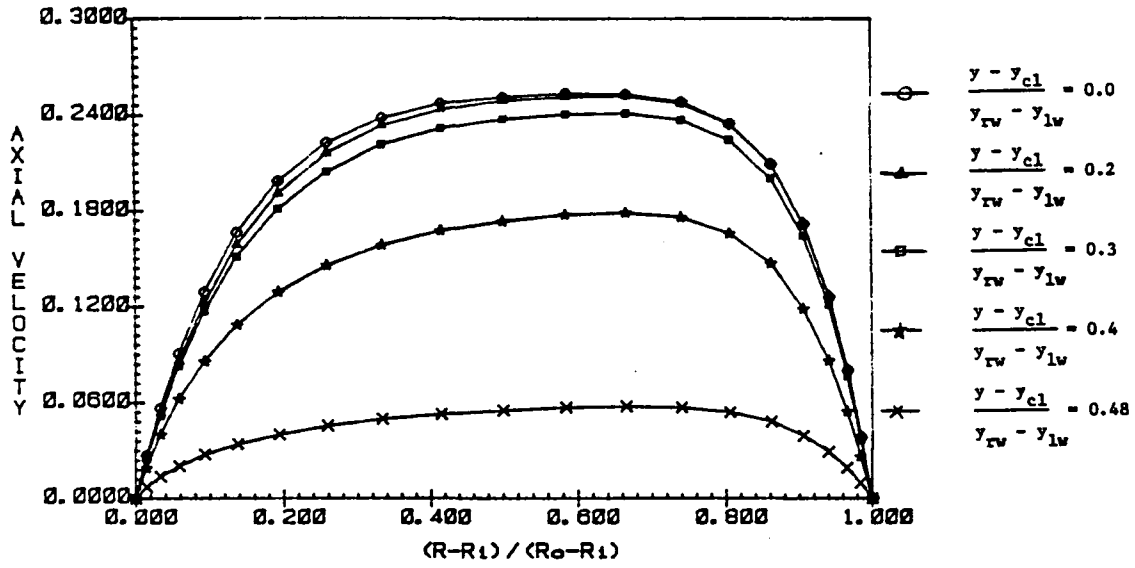

VELOCITY PLOT FOR TH=90.00 TIME STEP=240

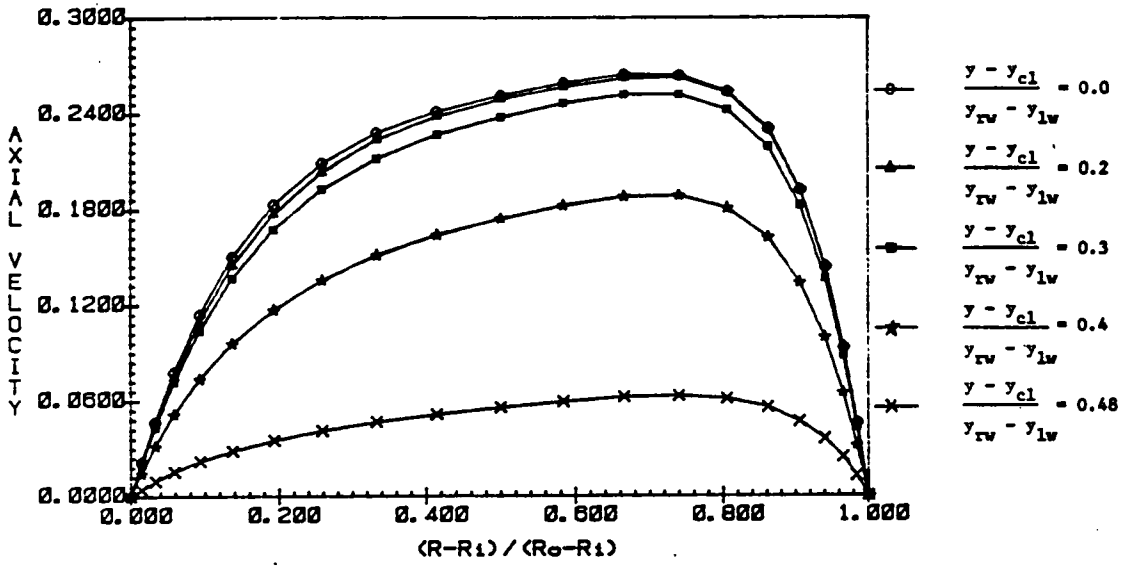

RADIAL VELOCITY FOR TH=90.00 TIME STEP=240

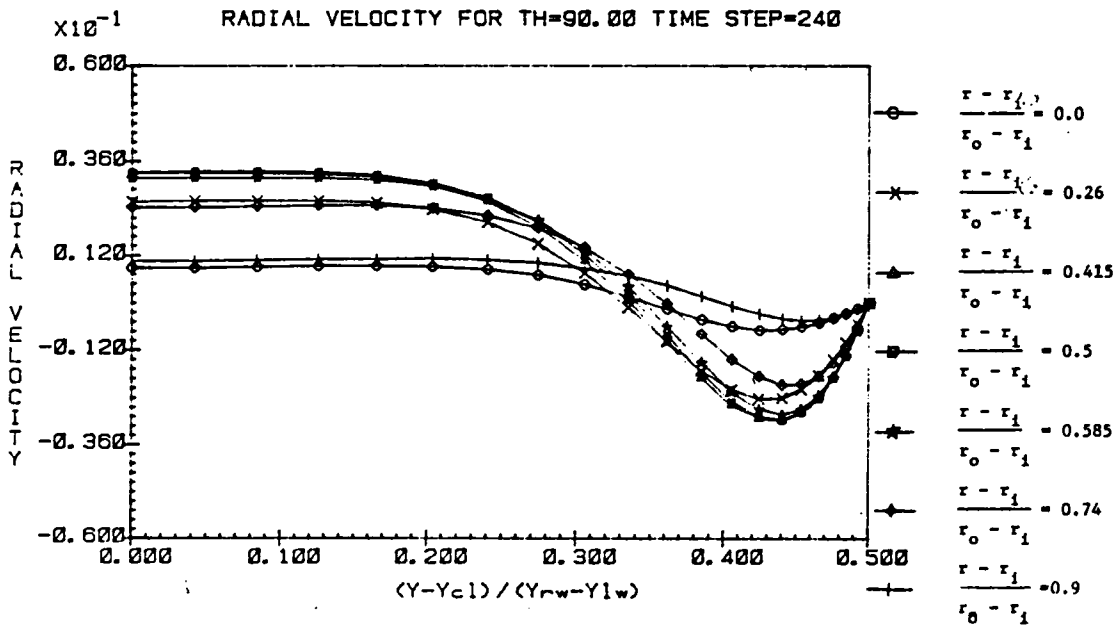

## STATUS SUMMARY

### EXPERIMENTAL

- DUCT DESIGN APPROVED - DETAILED DRAWINGS AND FABRICATION STAGES
- LV OPTICAL DESIGN BREADBOARDED - PREPARING FOR SHAKEDOWN TESTS (1/3 SCALE DUCT)
- LV PROCESSOR MODIFICATIONS UNDERWAY
  - 500 MHz CLOCK
  - 3D SIMULTANEITY
  - COMPUTER CONTROLLED POSITIONING
  - ON LINE DATA GRAPHICS

### ANALYTICAL

- CODES SELECTED FOR EVALUATION
  - P. D. THOMAS
  - "MINT"
- P. D. THOMAS CODE SET UP/OPERATIONAL FOR FLOW IN 90° BEND DUCT
  - RESULTS AGREE WITH PUBLISHED LITERATURE
- NOT YET ABLE TO ACQUIRE "MINT"

## FUTURE PLANS

### Phase 1

### EXPERIMENTAL

- COMPLETE DUCT FABRICATION, INSTALLATION AND SHAKEDOWN
- INITIATE 2-D LV MEASUREMENTS ON 1/3 SCALE DUCT TO DEVELOP ON-LINE DATA REDUCTION AND TRAVERSING SYSTEM SOFTWARE
- COMPLETE 3-D LV DEVELOPMENT AND SHAKEDOWN, ASCERTAINING MEASUREMENT UNCERTAINTIES AND COMPARABLE ACCURACY TO PROBES
- INITIATE ISOTHERMAL FLOW TESTS

### ANALYTICAL

- OBTAIN "MINT" AND INPUT BOUNDARY AND INITIAL CONDITIONS FOR DUCT WITH LAMINAR FLOW TO COMPARE WITH PUBLISHED RESULTS.
- INITIATE P. D. THOMAS AND "MINT" CODE COMPARISON WITH LAMINAR FLOW VISUALIZATION IN 1/3 SCALE DUCT
- EVALUATE/MODIFY TURBULENCE MODEL AND PREDICT TURBULENT FLOW WITH BOTH CODES.