

## COMMERCIALIZING THE TRANSFER ORBIT STAGE

by

Michael W. Miller  
Orbital Sciences Corporation  
Vienna, Virginia 22180

### ABSTRACT

Orbital Sciences Corporation (OSC), a technically-based management, marketing, and financial corporation, was formed in 1982 to provide economical space transportation hardware and services to commercial and government users. As its first project, OSC is developing a new medium-capacity upper stage for use on NASA's Space Shuttle, called the TOS. Before the TOS project successfully entered the development stage, many obstacles for a new company operating in the established space industry had to be overcome. This paper describes key milestones necessary to establish this new commercial space endeavor.

Historical milestones began with the selection of the project concept and synthesis of the company. This was followed by venture capital support which led to early discussions with NASA and the selection of a major aerospace company as prime contractor. A landmark agreement with NASA sanctioned the commercial TOS concept and provided the critical support necessary to raise the next round of venture capital. Future challenges including project management and customer commitments are also discussed.

### BACKGROUND

Orbital Sciences Corporation (OSC), a technically-based management, marketing, and financial corporation, was formed in 1982 to provide economical space transportation hardware and services to commercial and government users. As its first project, OSC is developing a new medium-capacity upper stage for use on NASA's Space Shuttle, called the Transfer Orbit Stage (TOS).

The TOS project represents an evolutionary milestone in the nation's attempts to commercialize space. Responding to the Reagan administration's mandate and to Congressional guidelines, NASA is encouraging private-sector initiatives in space activities. OSC's TOS program is foremost among a variety of commercial ventures being encouraged by the space agency. This paper will explore key features of the TOS program and this commercialization effort.

### PRELIMINARY MARKET STUDIES AND PROJECT SYNTHESIS

Since the introduction of NASA's Space Shuttle in 1981, the supply of launch services has shifted increasingly to a reliance on this reusable launch vehicle. The shift in payloads from ELVs to Shuttle has necessitated a need for a group of STS upper stages to boost payloads from the Shuttle low-Earth park orbit to their final geostationary locations. These upper stages can be aggregated into three categories according to their weight delivery capacity as follows:

- low capacity (1000 to 3000 lb capacity to geostationary orbit)
- medium capacity (3000 to 7000 lb capacity to geostationary orbit)
- high capacity (7000 to 12000 lb capacity to geostationary orbit)

At present, several low-capacity perigee stages, which perform the first of two required maneuvers to place satellites in geosynchronous orbit, are available in the capacity band from 1200 to 2200 lb of delivered payload. These upper stages, called Payload Assist Modules (PAM's), were developed commercially by McDonnell Douglas Corporation in a cooperative arrangement with NASA and are operationally compatible with the Delta ELV. McDonnell Douglas has flown over 15 PAM's to date and approximately 50 more are on the Shuttle manifest through the 1980's.

In the medium-capacity range, the Air Force's Inertial Upper Stage (IUS), which became operational on the STS in 1983, can deliver up to 5000 lb to geostationary orbit, in this case by providing both perigee and apogee boosts to the payload. Because of an array of special military requirements and concomitant high cost, the IUS is not generally an attractive launch option for commercial and NASA missions. No other upper stages now serve the medium-capacity segment, the segment which will show the fastest growth in commercial and government demand during 1985-1995.

At the upper end of the spectrum a large-capacity stage will be available in 1986 when the NASA/Air Force STS/Centaur is expected to be ready for a number of very high energy planetary and military missions. The Centaur is a liquid propellant stage that burns hydrogen and oxygen. It is a fairly complicated vehicle to build and operate requiring extensive safety modifications to the Shuttle Orbiter.

While the development of the Space Shuttle was proceeding in the U.S., the launch services market was being penetrated for the first time with serious competition from Europe. Ariespace's Ariane series, from Ariane 1 (2100 lb capacity to geo. orbit) which became operational in 1982, to Ariane 4 (5200 lb capacity to geo. orbit) which is planned for 1987, represents a serious threat to the U.S. dominance of the space transportation market. Aggressive marketing tactics, buttressed by government subsidies, have allowed Ariespace to attract several U.S. domestic communication satellite customers, even amid development delays and flight failures with Ariane 1.

OSC's evaluation of available upper stage systems and trends in satellite design led to the program to develop the TOS (see Figure 1). NASA, through feasibility and preliminary design studies conducted at Marshall Space Flight Center, identified the need for a low-cost, medium-capacity upper stage for use on the Shuttle. OSC's own market studies also led to the conclusion there was a substantial upper stage market for U.S. commercial, NASA, DOD, and international payloads in the same capability range.

Believing that a new business climate was developing for the propagation of commercial ventures in space in general, and space transportation services in specific, OSC in 1982 proposed to NASA that it finance, develop, and market the TOS as a commercial program similar to the PAM-D venture.

<b>SYSTEM</b>	<b>CAPACITY (lb)</b>	<b>COST (K\$/lb)</b>	<b>ILC*</b>
Shuttle/PAM-D	1,200	18.0	1982
Delta 3920/PAM-D	1,600	18.5	1981
Arian I	2,100	17.0	1982
Shuttle/PAM-A	2,200	18.0	1983
Atlas G/Centaur	2,700	24.0	1984
Ariane 3	3,100	16.0	1985
Titan 34D/IUS	4,100	34.0	1982
Shuttle/IUS	5,000	25.0	1983
Ariane 4	5,200	15.0	1987
Shuttle/TOS	6,800	12.0	1986
Shuttle/Centaur	12,000	14.0	1986

\*Initial launch capability (year).

Figure 1. Competitive Stage Assessment

## NASA AGREEMENT AND PROJECT TEAM

NASA entered into a Memorandum of Understanding with OSC in December 1982 for commercialization of the TOS. During the early part of 1983, OSC provided NASA with detailed information on its abilities and prospects for financing and managing the project. Extensive negotiations during early 1983 culminated in a landmark final agreement between NASA and OSC in April 1983, which transferred responsibility for the TOS program from the space agency to OSC.

In return for NASA's agreement to discontinue any Government-financed programs to develop a TOS-class stage, OSC promised to finance, develop, and become the exclusive marketing agent for the vehicle.

Among other features of this unique accord is NASA's commitment to establish a TOS project office at Marshall Space Flight Center (which is now operational). This office will participate as a technical monitor and adviser to OSC during TOS development and operation phases (1983-1994); will assist in STS safety, interface, and related activities; and will ultimately place NASA's "seal of approval" on the TOS system. This gives OSC's customers positive assurance of a dependable, cost effective stage for Shuttle applications.

During the second half of 1982, OSC held meetings with and reviewed technical and business proposals of seven aerospace companies interested in serving as the prime contractor and systems integrator for TOS. From this group, OSC selected Martin Marietta to develop, manufacture, test, and integrate the TOS because of its superior technical approach to TOS development (as corroborated by independent NASA assessments), innovative attitude toward cost savings, existing capability in Shuttle payload integration, and experience in space launch systems spanning a 25-year period. OSC and Martin Marietta signed a preliminary agreement to this effect in January 1983, and a final contract for vehicle design studies and full-scale development work in May 1983.

As prime contractor to OSC, Martin Marietta's Denver Aerospace Division will develop and produce the TOS and provide OSC's customers with payload integration and related launch services. As NASA's second largest contractor, Martin Marietta currently manufactures the external tank for the space shuttle and has a long history of working with NASA on important elements of the nation's space programs. Martin Marietta also serves as systems integrator to

the Air Force for defense payloads on the Space Shuttle. As manufacturer of the Titan 34D launch vehicle, Martin Marietta is well positioned to provide valuable assistance in arranging for the use of the Titan 34D as a backup for Space Shuttle launches of the TOS.

In addition, United Technologies' Chemical Systems Division has joined the project team as supplier of the solid rocket motor which powers the stage. The work of Martin Marietta and the Chemical Systems Division in these areas will be supervised by an OSC technical and contract management staff. The TOS Project Office, established under the terms of the NASA/OSC agreement at NASA's Marshall Space Flight Center, will ensure compliance with Space Shuttle flight safety requirements (See Figure 2).

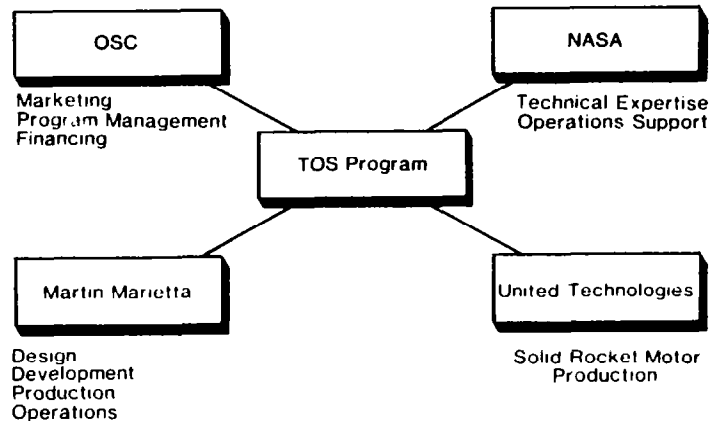

Figure 2. TOS Program Team.

## FINANCIAL CONSIDERATIONS

The funds required to meet TOS project requirements through 1986 are expected to be \$40 million. During 1983, OSC secured firm commitments of equity, debt, and limited partnership financing in excess of projected requirements. Joining OSC as financial partners in this project are four of the largest investment banking, venture capital, and financial services firms in the country. They include Rothschild, Inc. of New York, Brentwood Associates, Norwest Growth Fund, and Shearson/American Express, Inc. These financial partners represent, for the first time, the introduction of new sources of capital into space transportation activities. By meeting the financial requirements of the project before full-scale development, NASA and commercial users are guaranteed the TOS will be available.

## TECHNICAL AND PROGRAM FEATURES

The concepts of a commercial venture are embedded throughout the TOS development program. Basic to these are risk reduction measures to ensure the TOS will meet market needs, yet be available on schedule, and at a competitive price. To this end, the TOS will make maximum use of space-qualified, off-the-shelf hardware. For example, while the main propulsion system is based on the extensively tested and flight-proven SRM-1 rocket motor, most of the avionics, reaction control system, and electrical airborne support equipment are also already space-qualified. (See Figure 3).

New design features are incorporated where the commercial user will benefit. These include a length-efficient stage configuration and light-weight Shuttle cradle system to reduce launch costs. Interface compatibility with Ariane and PAM-DII precludes spacecraft attach fitting redesign. While common commercial requirements are met in a simple, low-cost design, mission-unique requirements are satisfied by add-on kits. Thus, TOS users will pay for only the services they need.

Finally, TOS users will be provided with not only hardware, but full "turn-key" services as well. These include spacecraft and payload integration, ground and flight operations, logistics management, and a full range of insurance and finance options.

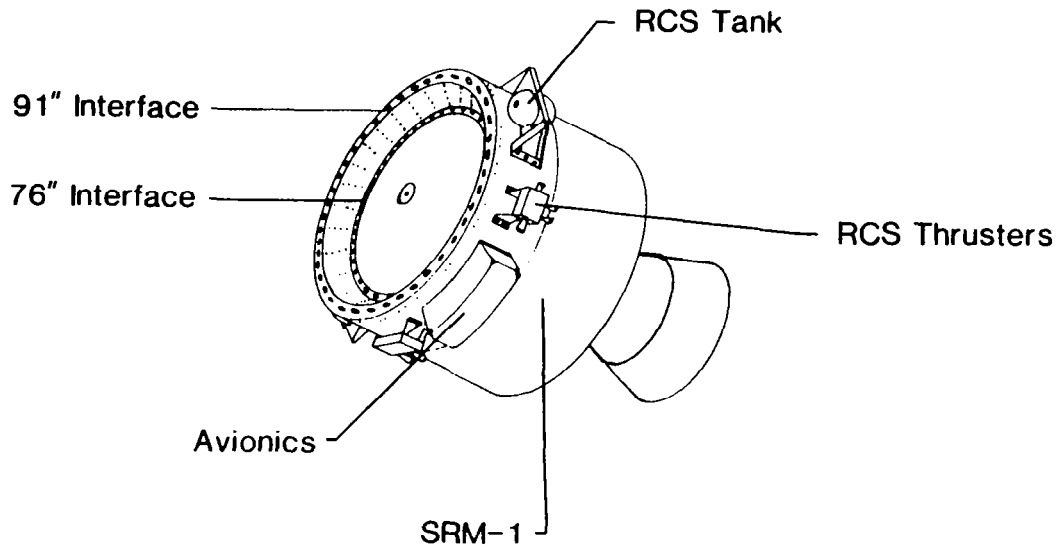

Figure 3. TOS System Configuration.

### PROGRAM STATUS

The TOS program is now moving through full-scale development with an expected initial launch capability of 1986 (See Figure 4). Design definition studies completed during 1983 provided confidence that the TOS will meet or exceed all its performance goals. During 1983, OSC opened their headquarters in a suburb of Washington, DC, and currently employs a 20 person staff in managing the TOS program and marketing the vehicle. The recent Reagan administration policies for the further development of private space endeavors has corroborated OSC's belief that its projects will help develop a new commercial space industry.

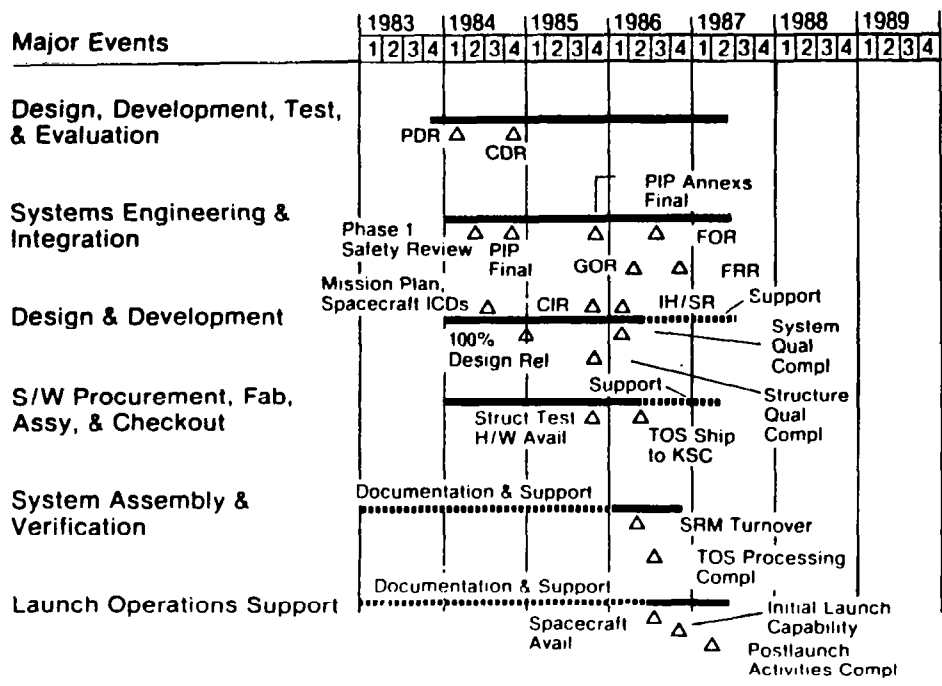

Figure 4. TOS Program Schedule.