

DEVELOPMENT AND CERTIFICATION OF A
NEW STALL WARNING AND AVOIDANCE SYSTEM

W.M. Gertsen
Group Engineer
Gates Learjet Corporation

and

J.D. Hawkins
Engineering Specialist
Gates Learjet Corporation

TABLE OF CONTENTS

	<u>PAGE</u>
I. ABSTRACT	1
II. SUMMARY	1
III. INTRODUCTION AND BACKGROUND	3
IV. ORIGINAL MODEL 55 STALL WARNING AND AVOIDANCE SYSTEM	5
A. System Description	
B. Functional Block Diagram	
C. System Performance	
V. ANALOG COMPUTER REPRESENTATION OF THE AIRPLANE & STALL WARNING AND AVOIDANCE SYSTEM	7
VI. MODIFICATIONS INVESTIGATED AND FLIGHT TESTED	7
A. First Modification	
B. Second Modification	
C. Third Modification	
D. Fourth Modification	
E. Fifth and Final Modification	
VII. STALL WARNING AND AVOIDANCE SYSTEM PERFORMANCE & TOLERANCE EFFECTS	17
VIII. STALL WARNING AND AVOIDANCE SYSTEM TURBULENCE SENSITIVITY AND TOLERANCE EFFECTS	20
IX. CONCLUSIONS	24

I. ABSTRACT

In order to improve natural stall characteristics, several methods may be employed. The method employed on all Learjets to obtain improved stall characteristics (either to prevent roll-off or pitch-up at the stall) has been a stall warning and avoidance system that employs angle-of-attack vanes, an electronic computer, a control column shaker motor, and a torquer which drives the control column in a pusher mode to avoid unwanted further build-up of angle-of-attack. The early systems were designed in such a way that the shaker and pusher actuation occurred only as a function of angle-of-attack. Later, time rate of change of vane angle ($\dot{\alpha}$) was added to permit higher angle-of-attack for pusher actuation. This permitted lower stall speeds with retention of satisfactory stall characteristics.

The new system, recently developed and FAA certified was developed with certain changes that improved system response with no performance penalty or increase in turbulence sensitivity. Changes that were made included modified system time constants and $\dot{\alpha}$ dead zone and the addition of an $\dot{\alpha}$ signal limiter and an $\dot{\alpha}$ cut-out below a specified angle-of-attack.

II. SUMMARY

Aircraft of the T-Tail configuration have, in general, a propensity toward steady state deep stall for aft center-of-gravity locations. Some aircraft avoid this flight regime by means of restrictions against loading behind the critical center-of-gravity. This approach is unsatisfactory for some configurations that require a wide range of center-of-gravity for operational efficacy. Some configurations with deep stall tendencies have been certified on the basis of placarding against stalls for loadings in the region where pitch-up can occur. However, today's regulatory environment discourages such a basis. Thus to improve stall characteristics, several methods have been employed. The method employed on all Learjets to obtain improved stall characteristics (either to avoid roll-off or pitch-up at the stall) has been a stall warning and avoidance system that employs angle-of-attack vanes, an electronic computer, a control column shaker, a nudger circuit, and a torquer which drives the control column in a pusher mode to avoid unwanted further build-up of angle-of-attack. (NOTE: The nudger circuit is a current (torque) limited push at a 3 Hz rate. The nudger function is utilized to indicate to the pilot that the pitch torquer is operating normally.) The early systems were designed in such a way that the shaker and pusher actuation occurred only as a function of angle-of-attack. With the advent of the Learjet Century III configurations in 1976, the desire to enhance safety by reducing takeoff and landing speeds led to adding time rate of change of vane angle ($\dot{\alpha}$) to the vane angle signal for shaker and pusher actuation. Because of this change the angle-of-attack for pusher actuation was raised to a point higher on the lift curve, while retaining satisfactory stall characteristics for the high entry rate stalls (4 kt/sec deceleration). The system as originally designed

had some inherent lag due to gust filtering to prevent nuisance actuation in turbulence, but no problems had been observed in many years of operational experience. It has been determined, however, that an unsteady approach to the stall with a pause in angle-of-attack increase (close to the stall) followed by a rapid increase in angle-of-attack could result in late firing of the pusher and pitch-up. The pusher must fire at or before a given angle-of-attack (depending on rate of increase in angle) in order to retain enough control authority to counteract the unstable moments that occur at extremely high angles. The pause that was mentioned above has the effect of resetting the stall warning system and its $\Delta\alpha$ lead to zero. The new system that has recently been certified was developed by making certain changes that improved system response with no performance penalty or increase in turbulence sensitivity. Changes that were made included modified system time constants and $\dot{\alpha}$ dead zone and the addition of an $\dot{\alpha}$ signal limiter and an $\dot{\alpha}$ cut-out below a specified angle-of-attack.

Figure 1 illustrates a normal steady approach to the stall, whereas Figure 2 is representative of the unsteady ('pause and pull') maneuvers referred to above.

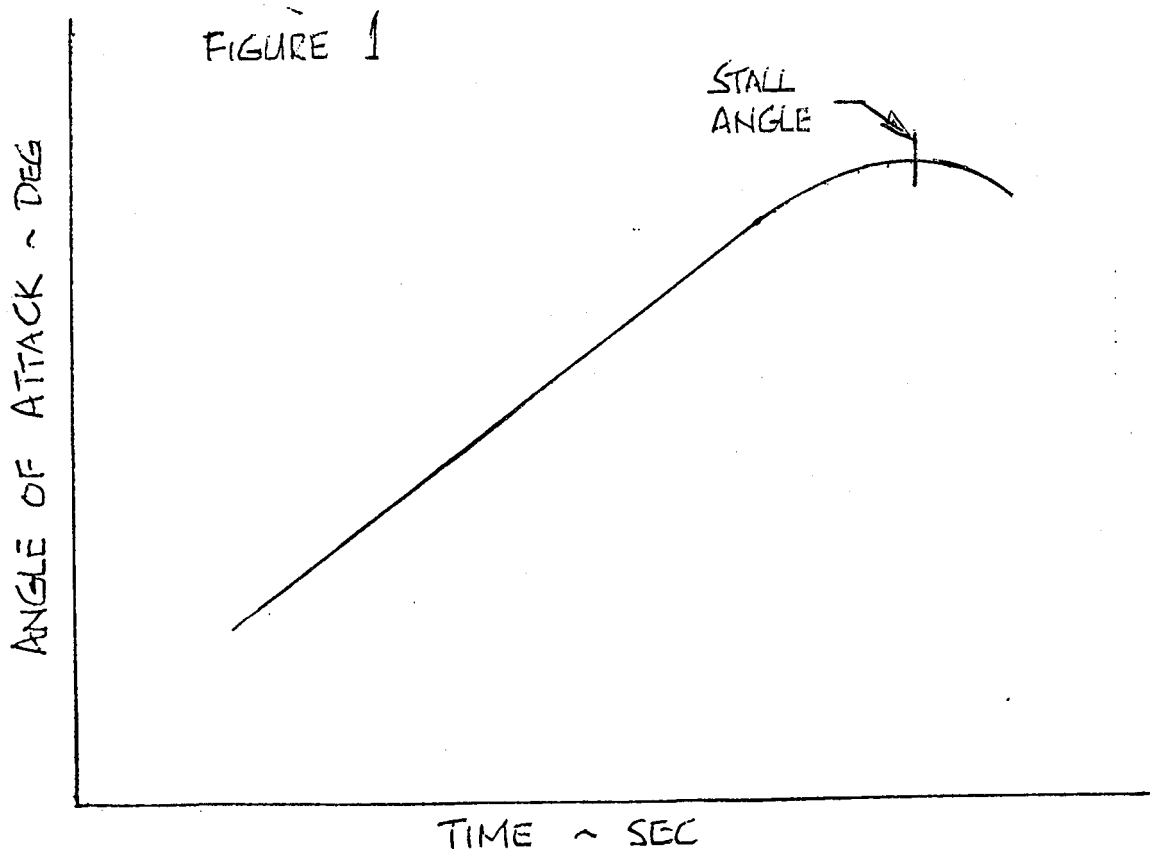

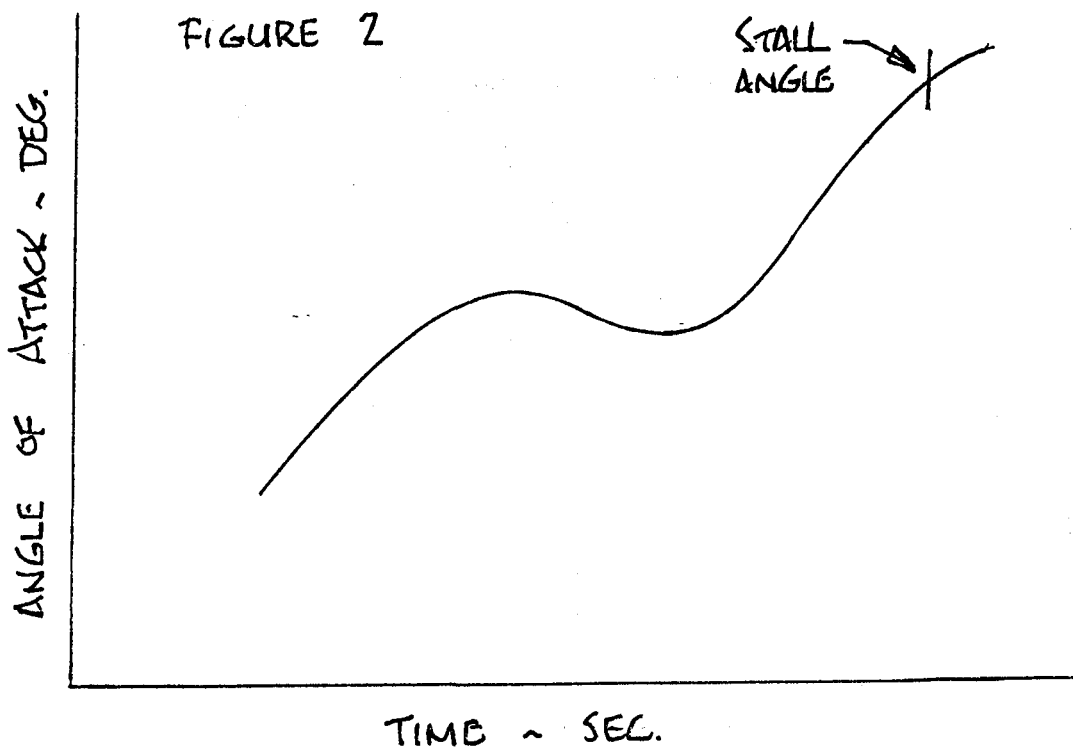

III. INTRODUCTION AND BACKGROUND

During developmental flight testing of the Learjet Model 23 it became apparent that the airplane would not meet the appropriate FAR's in the area of stall characteristics due to a wing drop tendency at the stall. Consequently, the original stall warning and avoidance system was developed to provide warning of the approach to the stall through a stick shaker that oscillates the control column at between two and three cycles per second through a small amplitude. The shaker actuation occurs at a speed approximately 7% above stall speed. In order to avoid inadvertent aerodynamic stall, a strong push force (equivalent to no less than 60 lb. of pilot force) is imparted to the pilot's control column. The push force remains constant until the angle of attack is reduced below the designated pusher angle. The pusher angle of attack is established to provide protection in the case of accelerated or high entry rate stalls (4 kt/sec deceleration). As can be seen in Figure 3, the requirement for pusher actuation to be at a lower angle of attack than the angle for aerodynamic stall results in higher effective stall speeds than would be the case if aerodynamic stall could be used. The consequence of this is higher takeoff and landing speeds and longer takeoff and landing distances.

In conjunction with the development of the Learjet Century III models in 1976, the desire to reduce stall speeds as much as possible led to a new stall warning and avoidance system that utilized an additional signal, that being time rate of change of vane angle ($\dot{\alpha}$). Because this signal added lead to the system response, the angle for pusher actuation could be raised to a point closer to the angle for CL_{MAX} as in Figure 4 below.

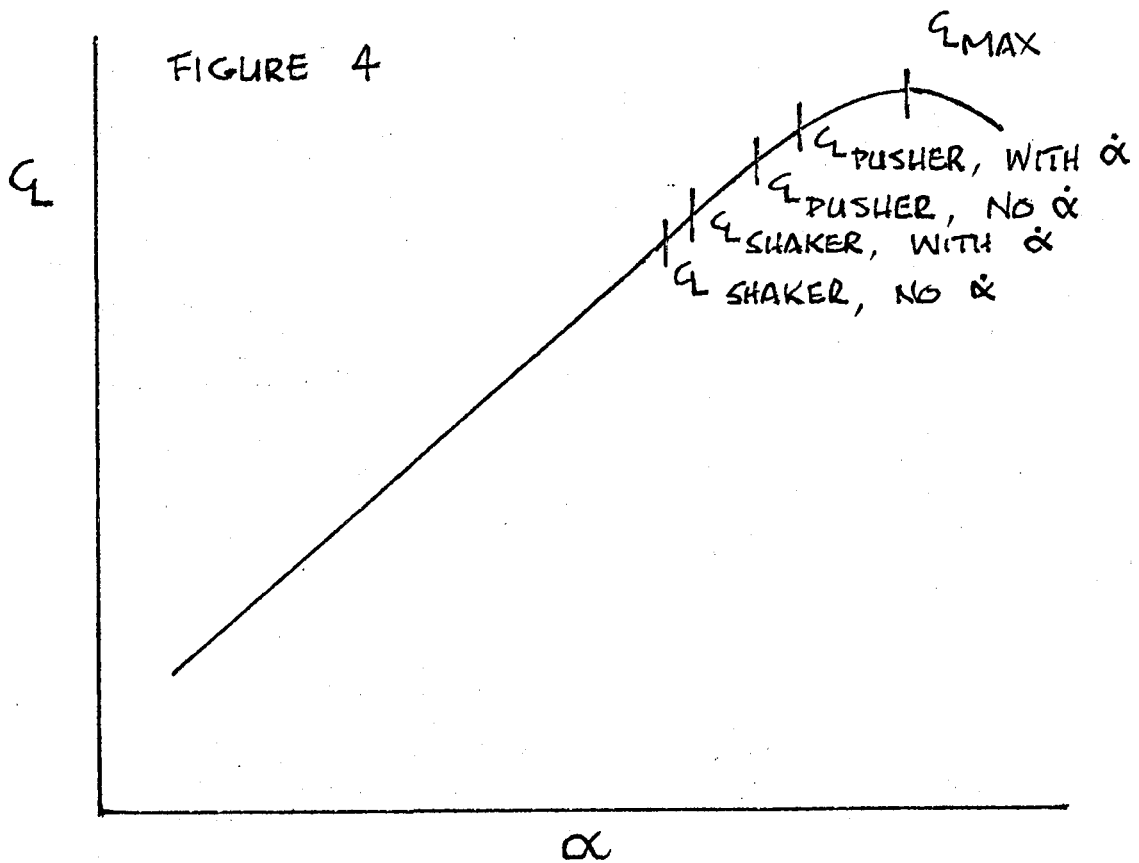
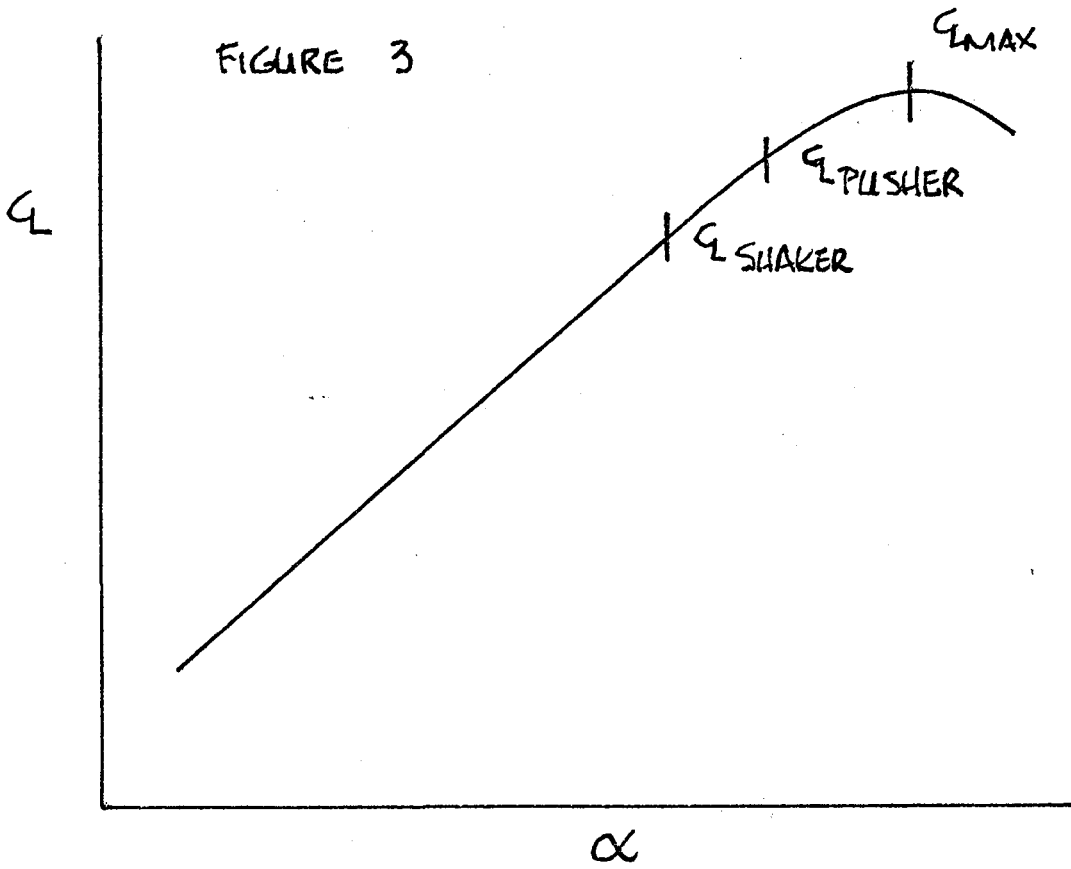

The result of adding the $\dot{\alpha}$ signal was reduced stall speeds, reduced takeoff and landing speeds, shorter field lengths, enhanced operational safety and retention of satisfactory stall characteristics for high entry rates.

IV. ORIGINAL MODEL 55 STALL WARNING AND AVOIDANCE SYSTEM

A. System Description

The original Model 55 stall warning and avoidance system was designed to be functionally similar to that in the earlier Model 35A. Only minor differences existed, such as small differences in time constants. The systems consist of dual vanes for sensing local angle of attack on each side of the fuselage somewhat ahead of the pilots station (see Figure 5), potentiometers, a dual angle of attack indicator, a dual computer, a dual accelerometers that deactivate the pusher when the airplane normal acceleration decreases to 0.5 g, and a servomotor that applies the appropriate pusher forces to the control column.

B. Functional Block Diagram

The stall warning and avoidance system functional block diagram is shown on Figure 6, next page. The forward loop converts vane angle to a voltage, amplifies and filters the signal to reduce the effects of turbulence to minimize nuisance firing of the shaker and pusher. The rate taker lead-lag circuit generates an effective signal and takes the signal through a dead zone or threshold. The signal is then summed with the signal and a flap bias signal. The summed signal is amplified and measured by a voltmeter. When the system output reaches 1.95 volts the shaker is actuated, and when the value goes to 0 volts, the pusher is actuated.

FIGURE 5

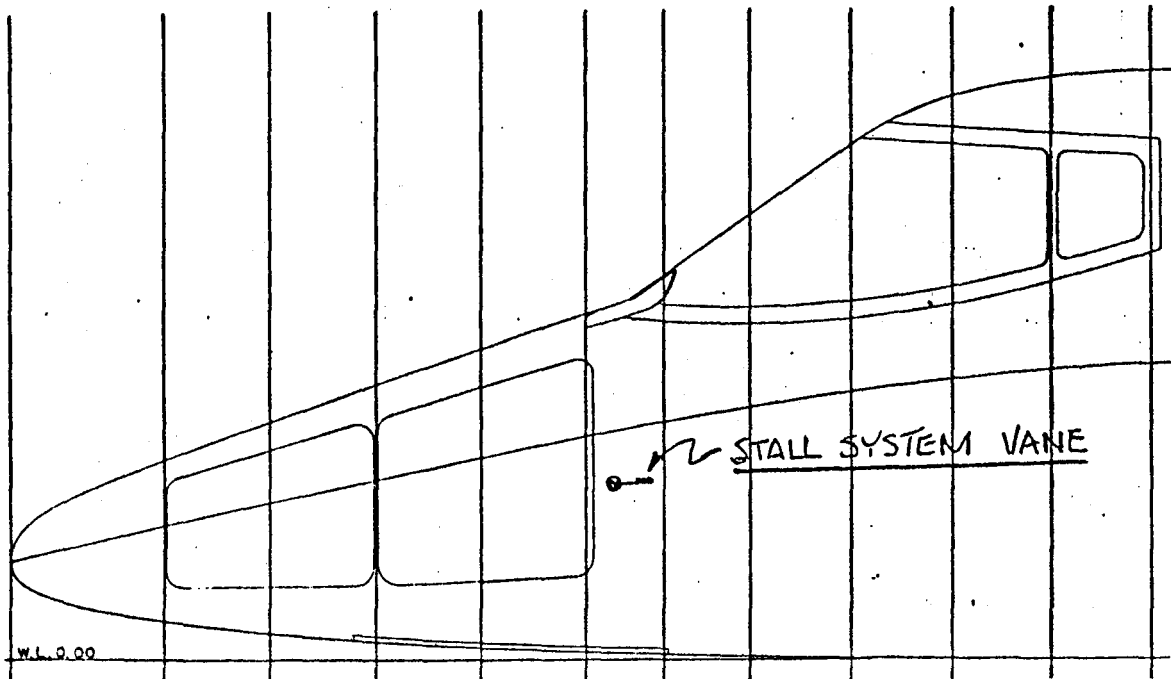

MODEL 55
STALL WARNING
SYSTEM

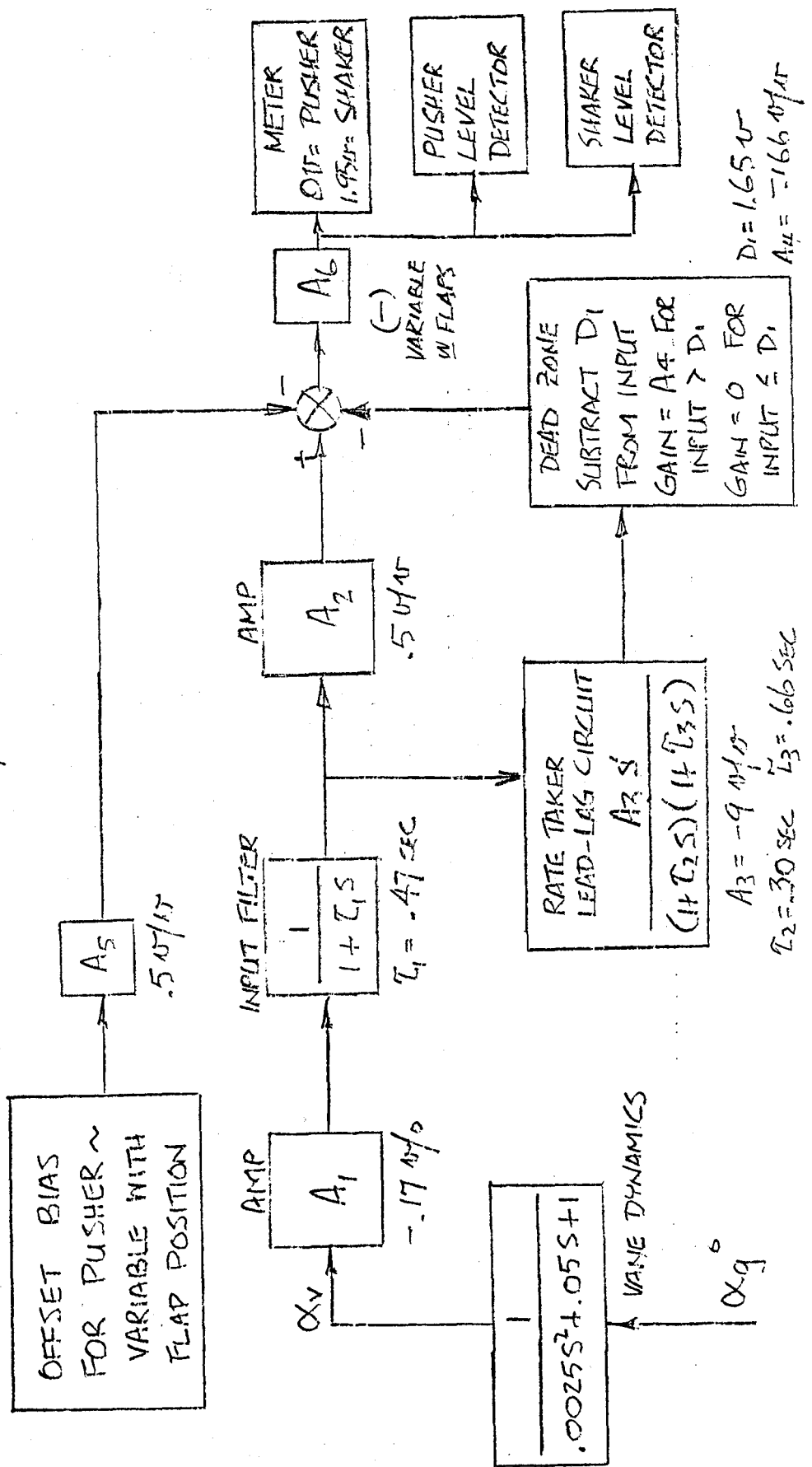

C. System Performance

If the system block diagram is converted into the equivalent differential equations, the system response to a ramp input of vane rate can be calculated for various values of vane rate and for various initial values of vane angles below the pusher ground set angle. The results of a series of such calculations have been plotted and are presented in Figures 7 and 8. The solid lines represent the baseline or original Model 55 system performance, while the new (modified) system performance is given by the dashed lines. For example, for an initial vane angle at 10° below pusher angle and for a vane rate of 10 deg/sec, the system would actuate the pusher at 1.3° before the static setting of 27° . Thus the pusher would fire at 25.7° vane angle.

By comparison, the new system would actuate the pusher at a point 5.4° prior to 27° , or at 21.6° , thus affording 4.1° more lead than the original (baseline) system. Figure 9 is similar to the previous two charts but only 5° away from pusher is shown for the several configurations tested during the flight test program.

V. ANALOG COMPUTER REPRESENTATION OF THE AIRPLANE & STALL WARNING AND AVOIDANCE SYSTEM

The mathematical model of the airplane degrees of freedom and the stall warning and avoidance system are shown on Figures 10 through 14 in analog computer diagram form. The digital computer program that was used for the analytical studies accepts as input data the problem formulation in analog format. Figure 10 contains the forcing functions available, which are a ramp, a continuous sine wave, of variable frequency and magnitude, a one-cycle (1-cosine) discrete disturbance of variable wave length and amplitude, and a random disturbance of variable intensity. Next, Figure 12 represents the stall warning system shown functionally in Figure 10. The airplane longitudinal degrees of freedom are shown in Figures 13 and 14.

VI. MODIFICATIONS INVESTIGATED AND FLIGHT TESTED

A large number of modifications were investigated analytically by means of the computer program described in Section V above. The purpose of the analytical work was to evaluate before flight testing all proposed modifications and thus minimize the number of flight hours required to achieve the program objectives. Of all the configurations analyzed only five were actually flown and tested. These five modifications will be discussed in the following paragraphs. The ground rules for the project were that the stall warning and avoidance system modifications had to be relatively simple, such as substitution of one value of component for another, and with no loss in airplane performance capability, and retention of acceptable turbulence sensitivity. Analytical investigations included system response for the nominal system and for the system with the maximum adverse component tolerances. Also analyzed was the system response in turbulence for the nominal system and for the system with the maximum adverse system tolerances.

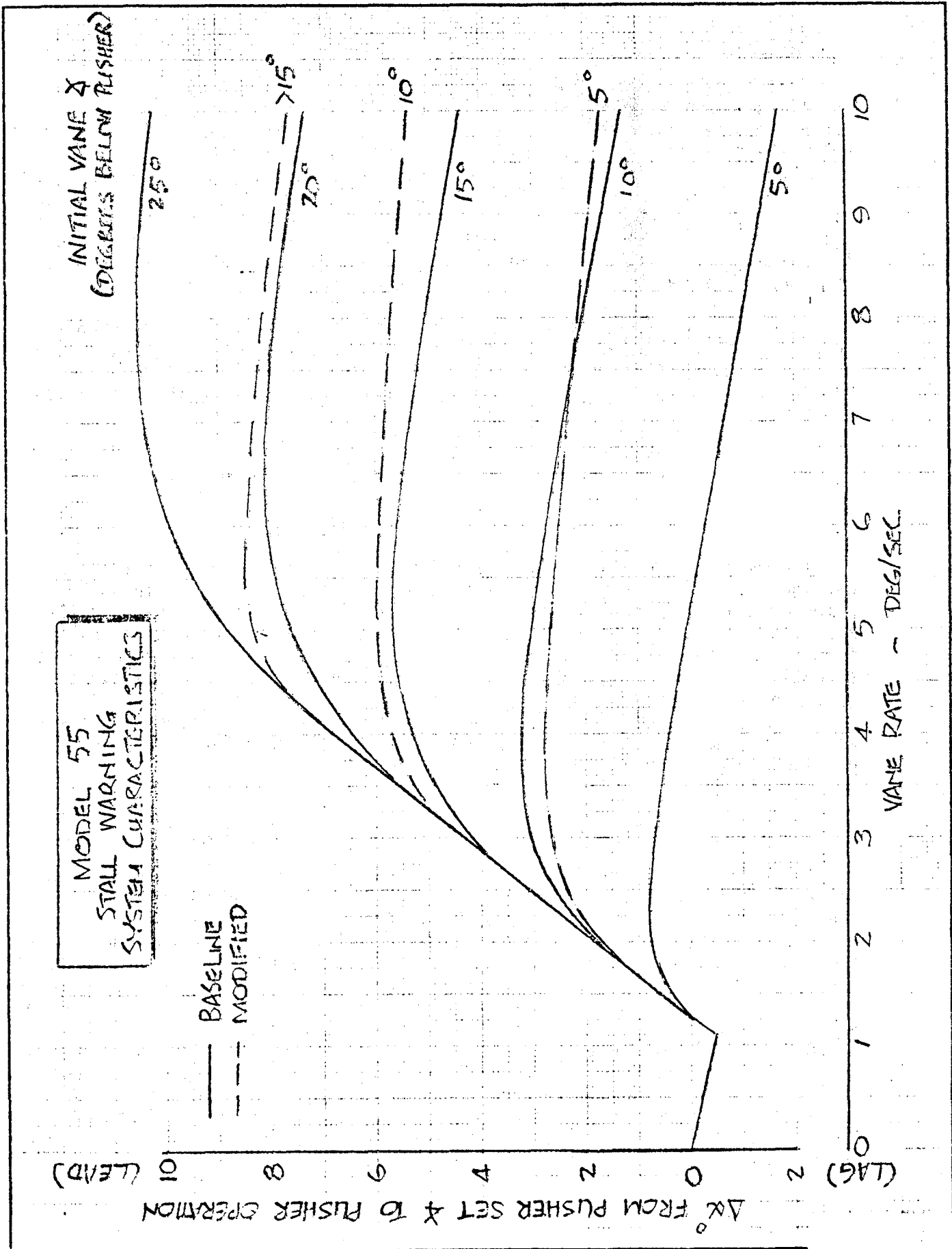

figure 7

MODEL 55
STALL WARNING
SYSTEM CHARACTERISTICS

— BASELINE
- - - MODIFIED

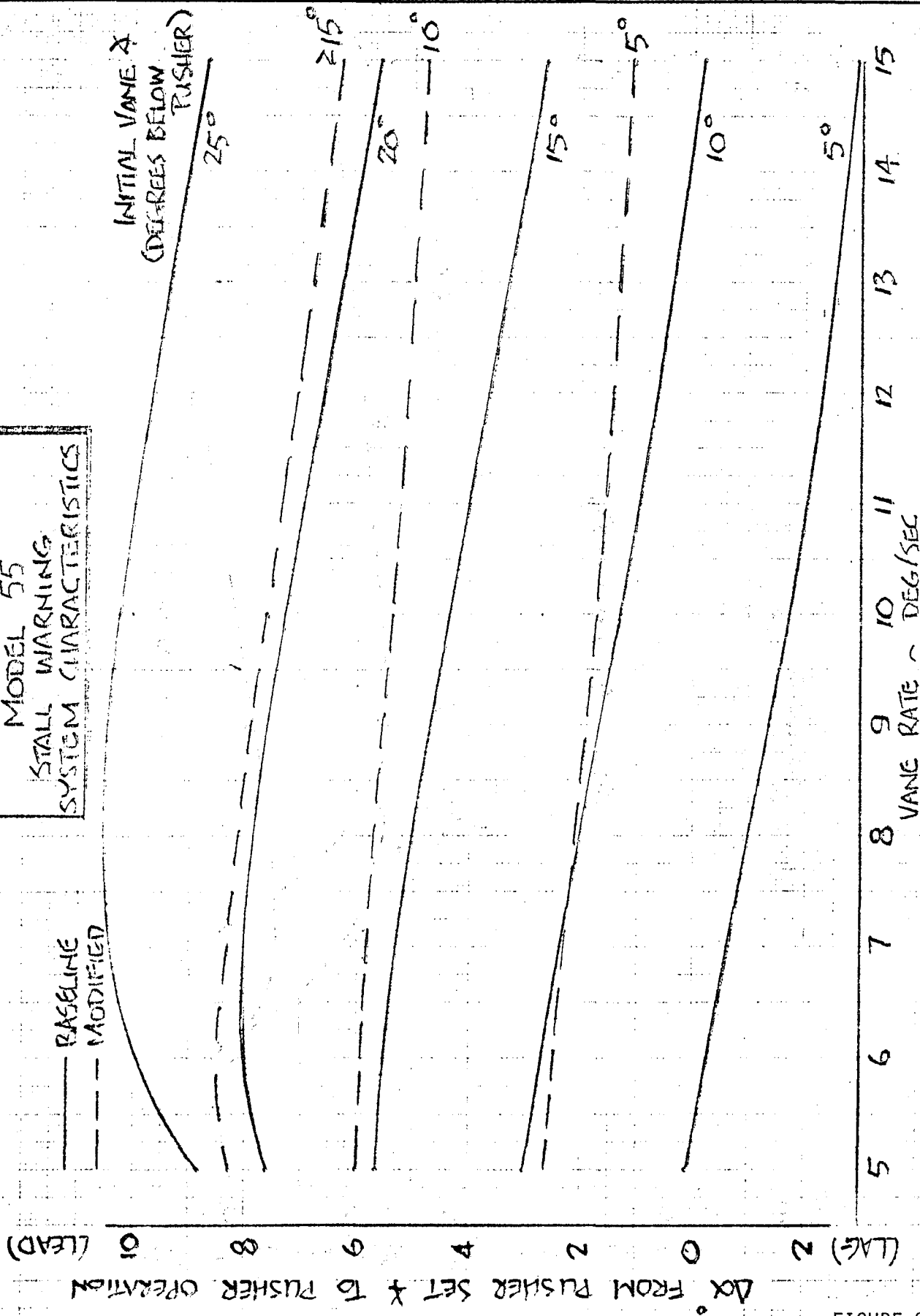

FIGURE 8

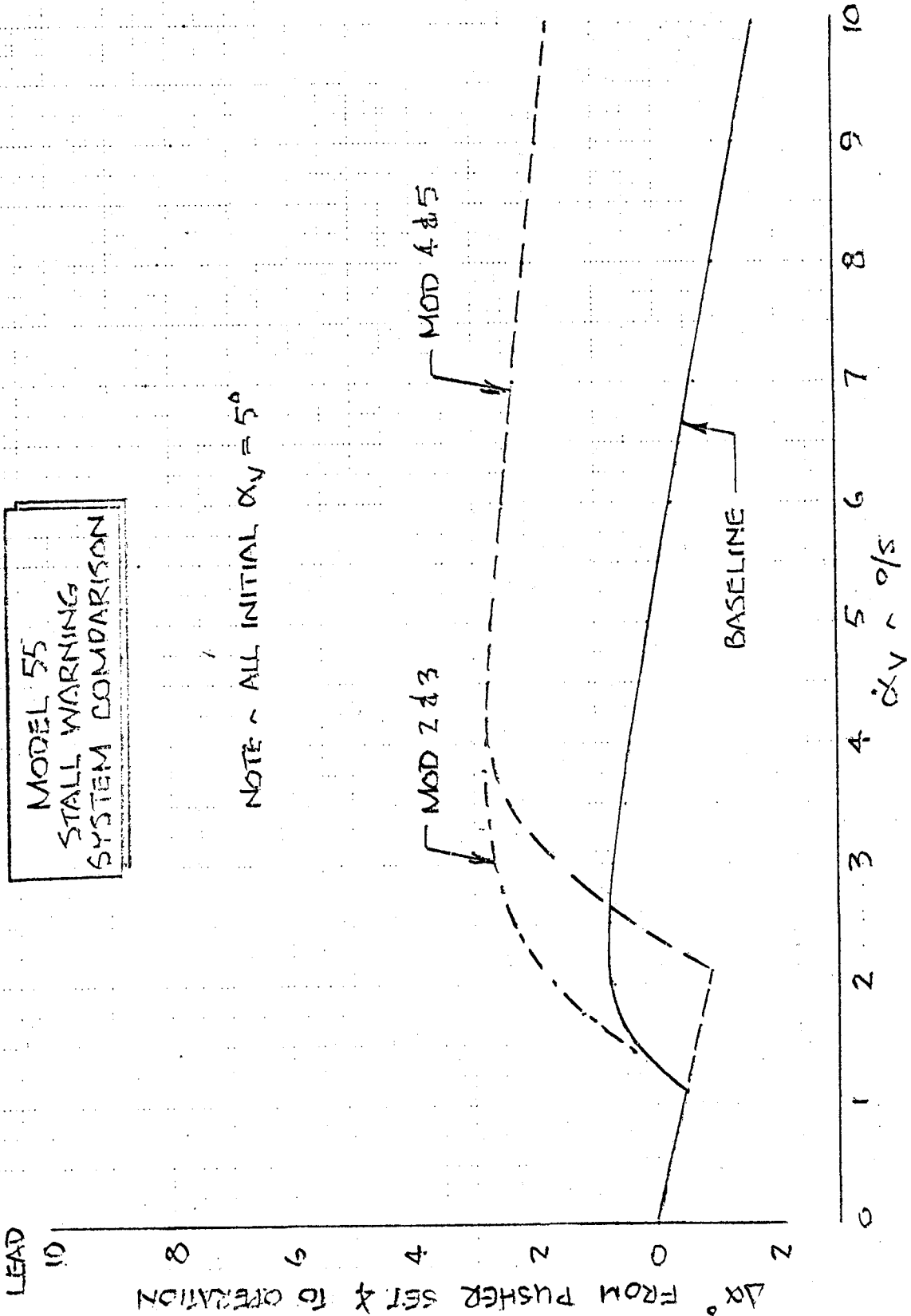
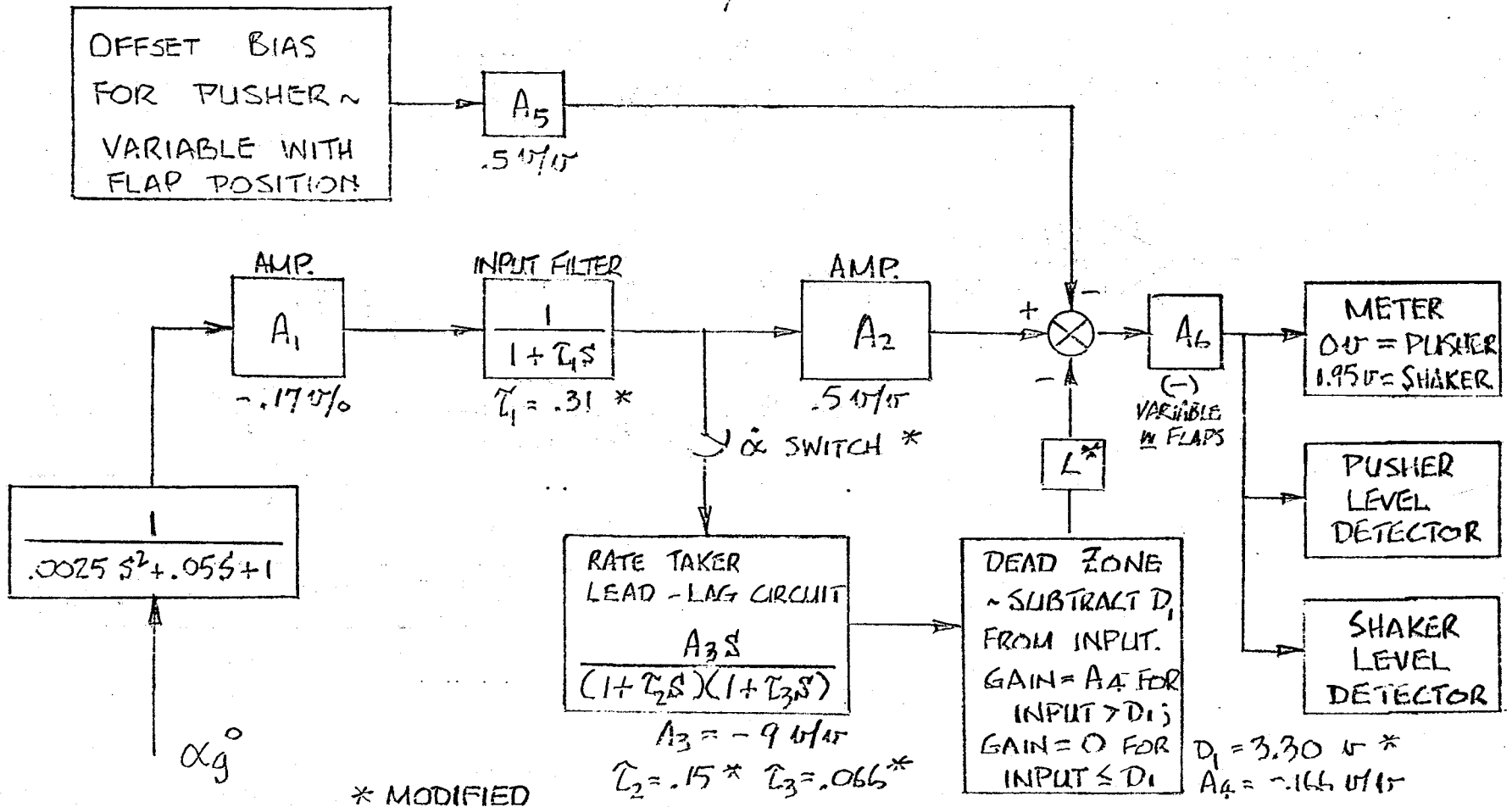

figure 9

MODEL 55
IMPROVED
STALL WARNING
SYSTEM



313

FIGURE 10

FORCING FUNCTIONS

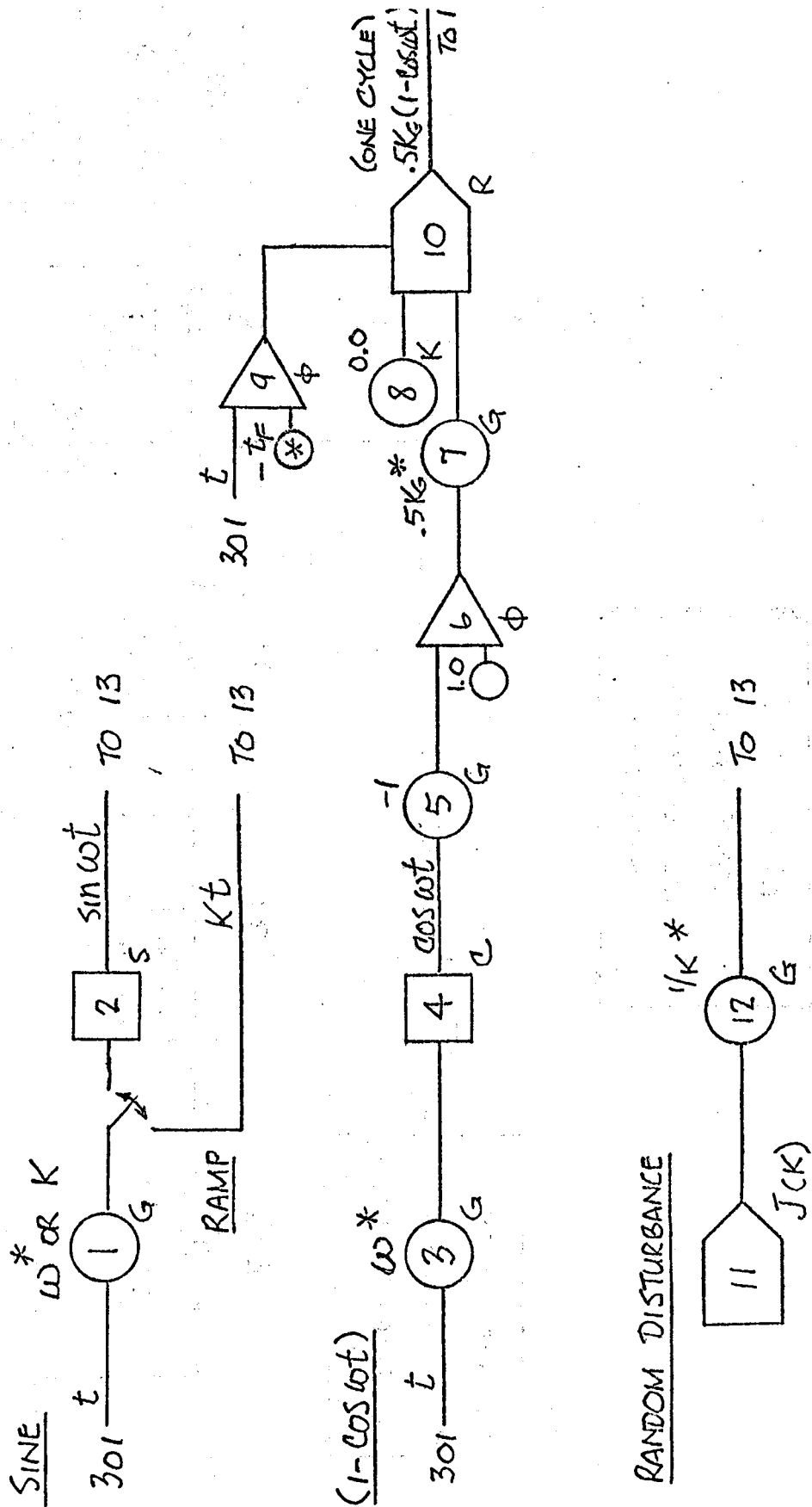

* VARIABLE

STALL WARNING SYSTEM

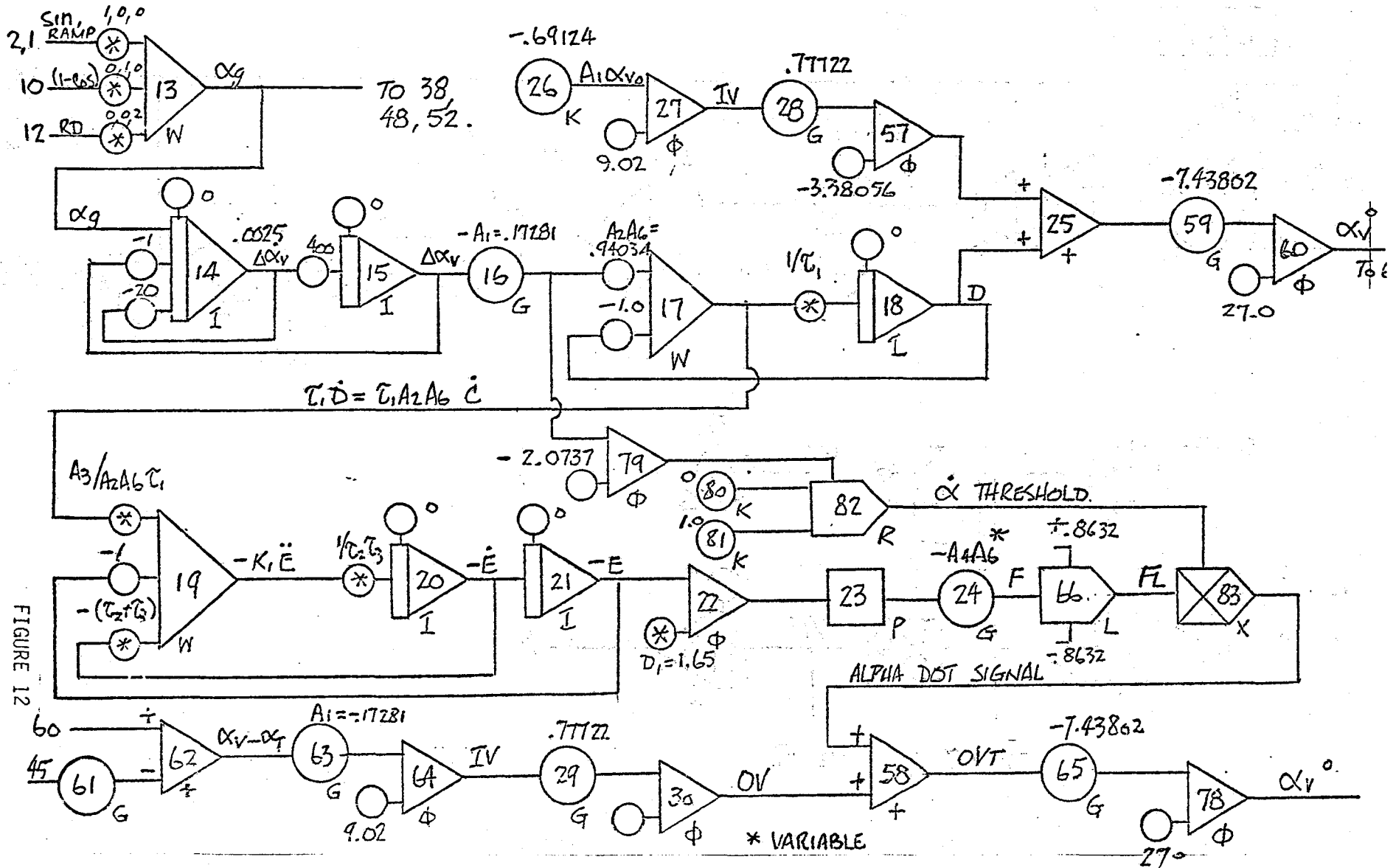

FIGURE 12

THREE DOF LONGITUDINAL SIMULATION

LIST

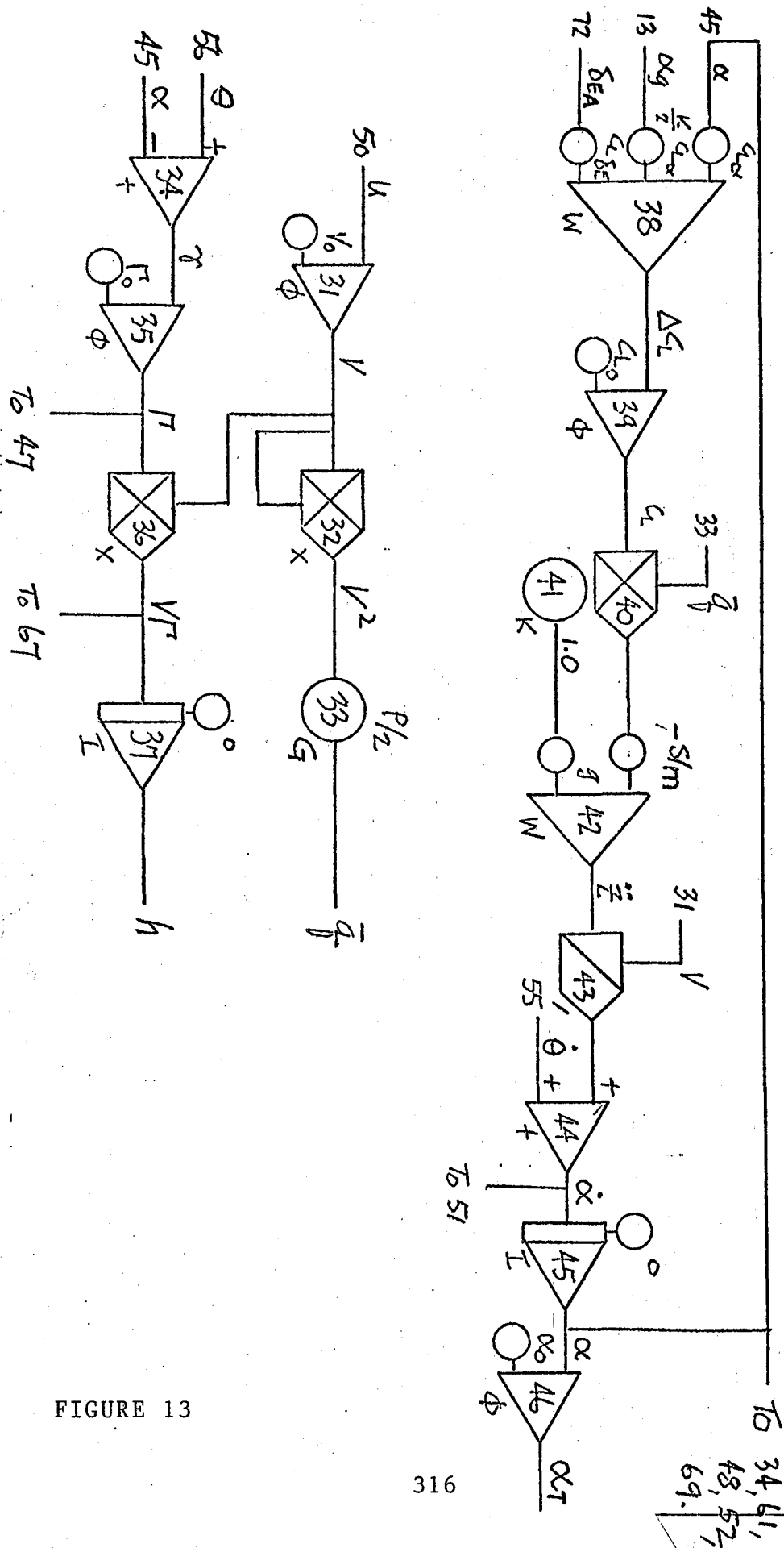
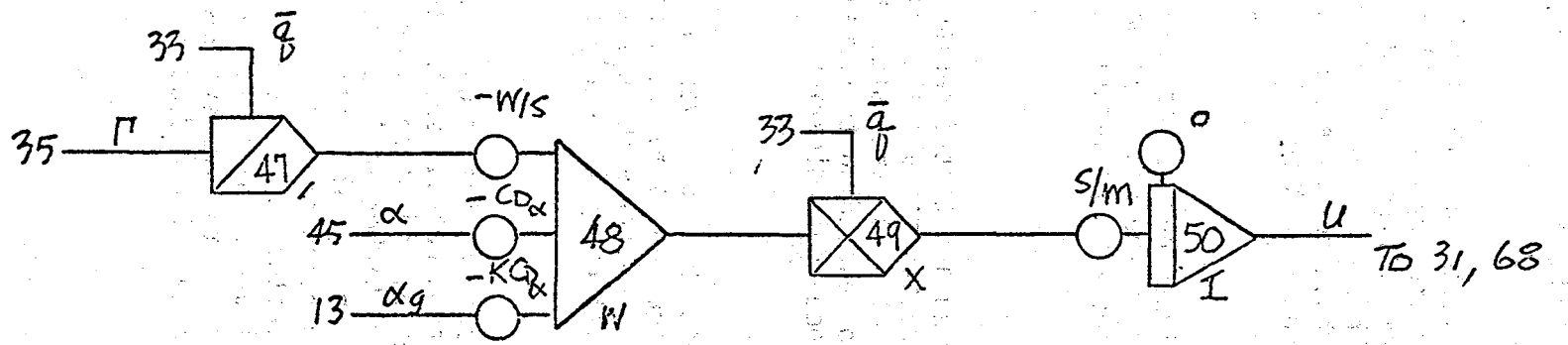

FIGURE 13

DRAG



PITCHING MOMENT

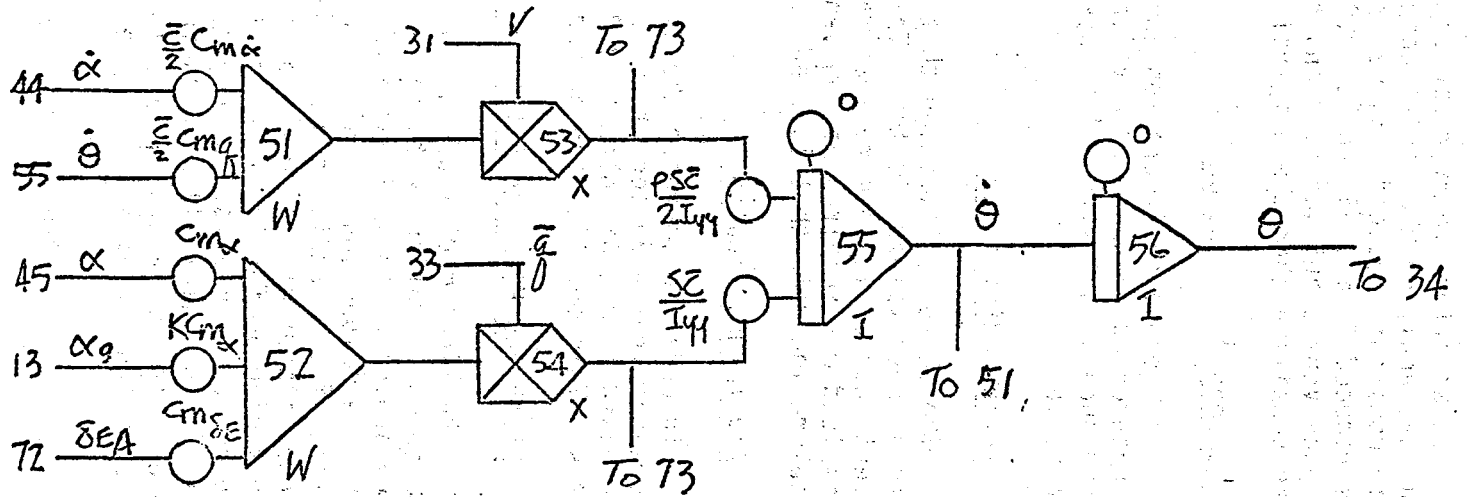

FIGURE 14

A. First Modification

In an effort to overcome some of the system lag, the first modification that was analyzed and tested both in the laboratory and in flight had two time constants reduced. τ_1 was reduced from 0.47 sec. to 0.31 sec., and τ_3 was reduced from 0.66 sec. to 0.066 sec. This configuration gave sufficient responsiveness but was too sensitive in turbulence. The system was noticeably more sensitive than the original Model 55 configuration.

B. Second Modification

The second configuration that was analyzed and tested retained the τ_1 and τ_3 changes but also added a voltage limiter in the $\dot{\alpha}$ circuit to reduce the turbulence sensitivity. This system provided an improvement but was still too sensitive.

C. Third Modification

The third modification that was analyzed and tested replaced the limiter with a lower valued limiter. This configuration met all the original criteria except that a little more lead was desired at high vane rates, and a little less lead was required at low vane rates corresponding to normal 1 kt/sec deceleration rate that is used for stall speed determination.

D. Fourth Modification

In order to increase the system lead at the higher vane rates, τ_2 was decreased from 0.30 sec. to 0.15 sec. At the same time the $\dot{\alpha}$ dead zone was increased from 1.65 volts to 3.3 volts to desensitize the system at low vane rates. This modification proved to be satisfactory in nearly every respect.

E. Fifth and Final Modification

The final modification that was analyzed and tested was the same as the fourth modification, with the addition of an $\dot{\alpha}$ cut-out switch that is open at vane angles up to just above the shaker angle, and closed above that point. Thus the $\dot{\alpha}$ function is only in effect in the higher angle of attack range. The effect of this addition was to desensitize the system still further in turbulence without affecting the basic system function at or near the stall. The block diagram for the final configuration tested and FAA certified is shown in Figure 10. Comparison of Figure 10 with Figure 6 which represents the original unmodified system illustrates the similarity of the two systems. In summary, three time constants, τ_1 , τ_2 , τ_3 were decreased, the $\dot{\alpha}$ dead zone was increased, an $\dot{\alpha}$ switch and an $\dot{\alpha}$ limiter were added.

VII. STALL WARNING AND AVOIDANCE SYSTEM
PERFORMANCE AND TOLERANCE EFFECTS

The system performance curves shown previously on Figures 7 and 8 were generated analytically by using a ramp input in vane angle at various vane rates. The system performance was also checked by tying the actual system computer to a fast Fourier analyzer and obtaining performance data. Then during actual flight testing, the system performance was closely monitored by means of a telemetry system that is routinely used at GLC for certain exploratory testing. All three sources of data correlated very well throughout the flight test program. The good correlation increased the confidence level in new configurations before flight, and also helped to identify problems with hardware as they occurred during the program. Figure 15 is a typical working plot that was used during the course of the telemetered flights. The deep stall region had previously been estimated from wind tunnel data and revised as flight test data was accumulated. By plotting points on such a plot as the testing progressed the test pilot could be immediately informed concerning the validity of the previous test condition and could be cleared to perform the next test point, or advised to discontinue the test series. He was also advised concerning the magnitude of his control inputs and rates, and angles obtained compared with expected values. The learning curve was thereby accelerated and safety enhanced. Figure 16 is a plot of pitch acceleration available through elevator input as a function of vane angle at the time of maximum recovery nose down elevator input. As zero pitch acceleration is approached, recovery with elevator alone is not possible. This plot was useful in establishing the estimated deep stall boundary shown on Figure 15.

For tolerance effects, a maximum build-up of component tolerances was assumed in the direction of minimum system responsiveness. Tolerance values used are as follows:

- A₁: ±5%
- A₂: ±2%
- A₃: ±10%
- A₄: ±2%
- A₅: ±2%
- τ₁: ±15%
- τ₂: ±15%
- D₁: ±20%
- L: ±20%

System performance was calculated for the maximum tolerance case for several values of vane angular rate and initial vane angle. For the critical range of rates (10-15°/sec) and initial vane angle (5-10° below pusher angle) the loss in

55-001
 $\dot{\alpha}$ M4
 F=40
 GEAR DOWN

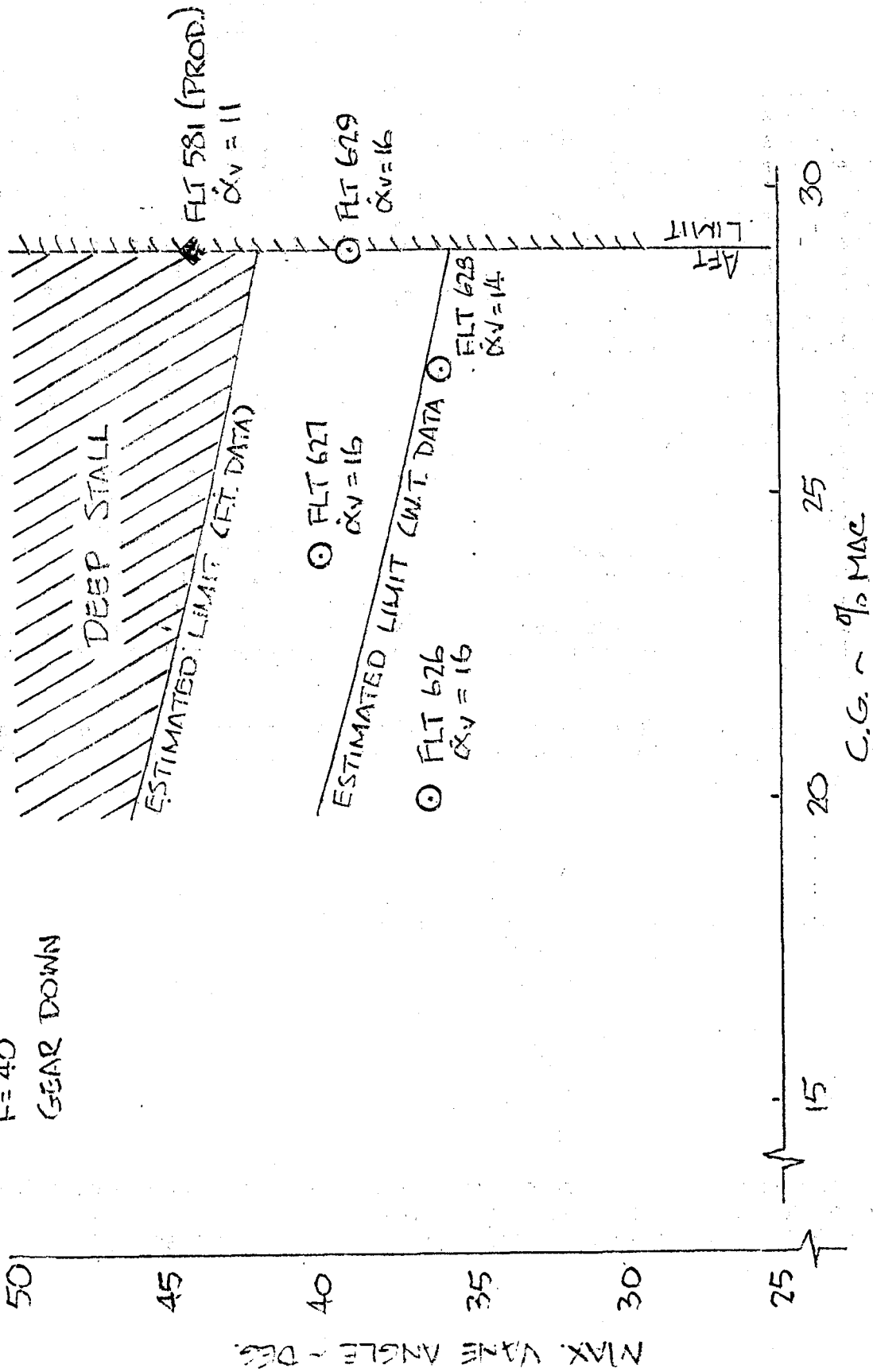

figure 15

55-001 SWS DEVELOPMENT, MA

\triangle F = 8°
 \square F = 20°
 \circ F = 40°
 FLAG ~ GEAR UP
 OPEN ~ CG = 24%
 HALF SHADE ~ CG = 27%
 FULL SHADE ~ CG = 29%

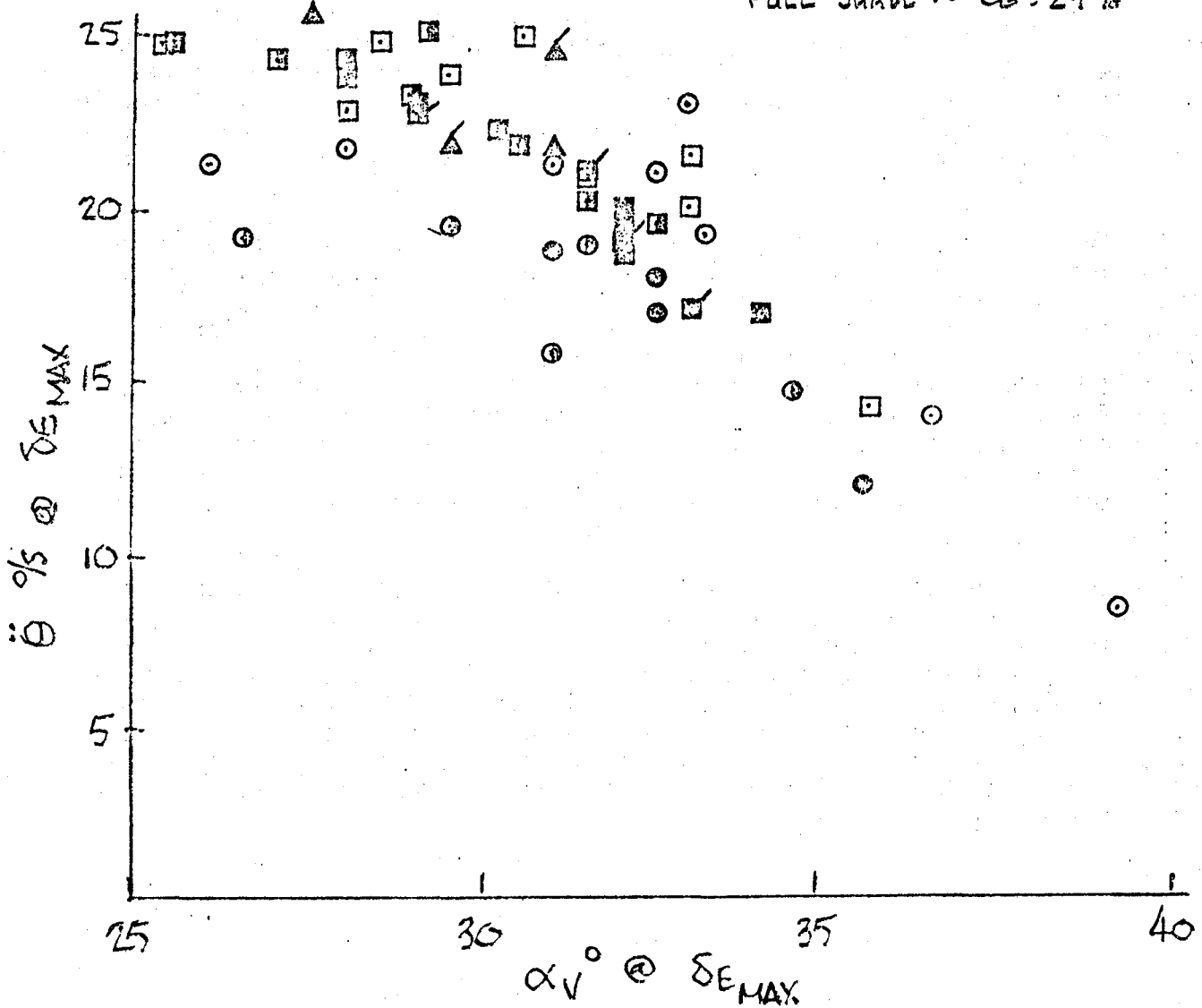

FIGURE 16

lead was found to be approximately 1.5° . Additional system tolerances were found to add 2.0° for a total of 3.5° . Accordingly for purposes of flight testing the system the pusher was set to fire 3.5° higher than the production setting. All the test conditions were accomplished satisfactorily. Thus it was concluded that the expected component and system tolerances will be satisfactory for production and for use in the field.

VIII. STALL WARNING AND AVOIDANCE SYSTEM

TURBULENCE SENSITIVITY AND TOLERANCE EFFECTS

In addition to the primary concern of system function for stall warning and avoidance, another important consideration is the sensitivity of the system in atmospheric turbulence and the resulting frequency of nuisance shaker and pusher occurrences. The criterion that was used in the development of the new system was that the new system should have approximately the same or less turbulence sensitivity as the original system. In order to investigate this prior to flight each candidate system was analyzed with the computer program described in Section V of this paper. The baseline (original) system was also investigated. All the systems were analyzed for effects of maximum tolerance build-up of the various system components. In the case of turbulence effects, tolerances in the direction toward greatest responsiveness were investigated, whereas for the primary function of the system, maximum tolerances in the direction of least responsiveness were analyzed.

Two types of turbulence environments were used. The first was a 15 ft/sec (1-cosine) discreet gust across a spectrum of wavelengths that was sufficient to define a maximum system response point. Figure 17 presents the results of this part of the study for the baseline system and for the final configuration (Mod. 5) in the form of maximum output voltage vs frequency. The modified system exhibits less sensitivity to the discrete gusts and much less sensitivity to the effects of system component tolerances. The magnitude of the gust input was based upon the assumption that if the root mean square (RMS) turbulence level exceeds 5 ft/sec., a landing would not be attempted. Therefore, 15 ft/sec. (3σ) was selected as the largest probable gust that would be encountered in a landing situation.

The second type of turbulence environment that was used was simulated random turbulence of varying intensity up to an extremely heavy 20 ft/sec. RMS. System response in the form of maximum voltage range vs turbulence intensity is shown in Figure 18. Similarly Figure 19 shows number of shaker occurrences as a function of turbulence intensity. For reasonable levels of turbulence the new system response was comparable to the old. Based upon the analytical studies, laboratory hardware tests and flight tests of the prototype system in turbulent air, it was concluded that the modified stall warning system was better than the original and less likely to cause nuisance pusher occurrences.

MODEL 55
 STALL WARNING SYSTEM
 RESPONSE TO DISCRETE
 GUST ~ 15 KSEC (1-00S.)

MOD. 5

$\tau_1 = .31$
 $\tau_2 = .15$
 $\tau_3 = .066$
 $L^* = .86$
 $DB = 3.3$

FLAPS = 40°, GEAR DOWN
 W = 17344 LB., AFT CG.
 h = 14300 FT., $V_K = 134$

○ BASELINE
 ⊙ BASELINE, MAX. TOL.
 △ MOD. 5
 ▲ MOD. 5, MAX. TOL.

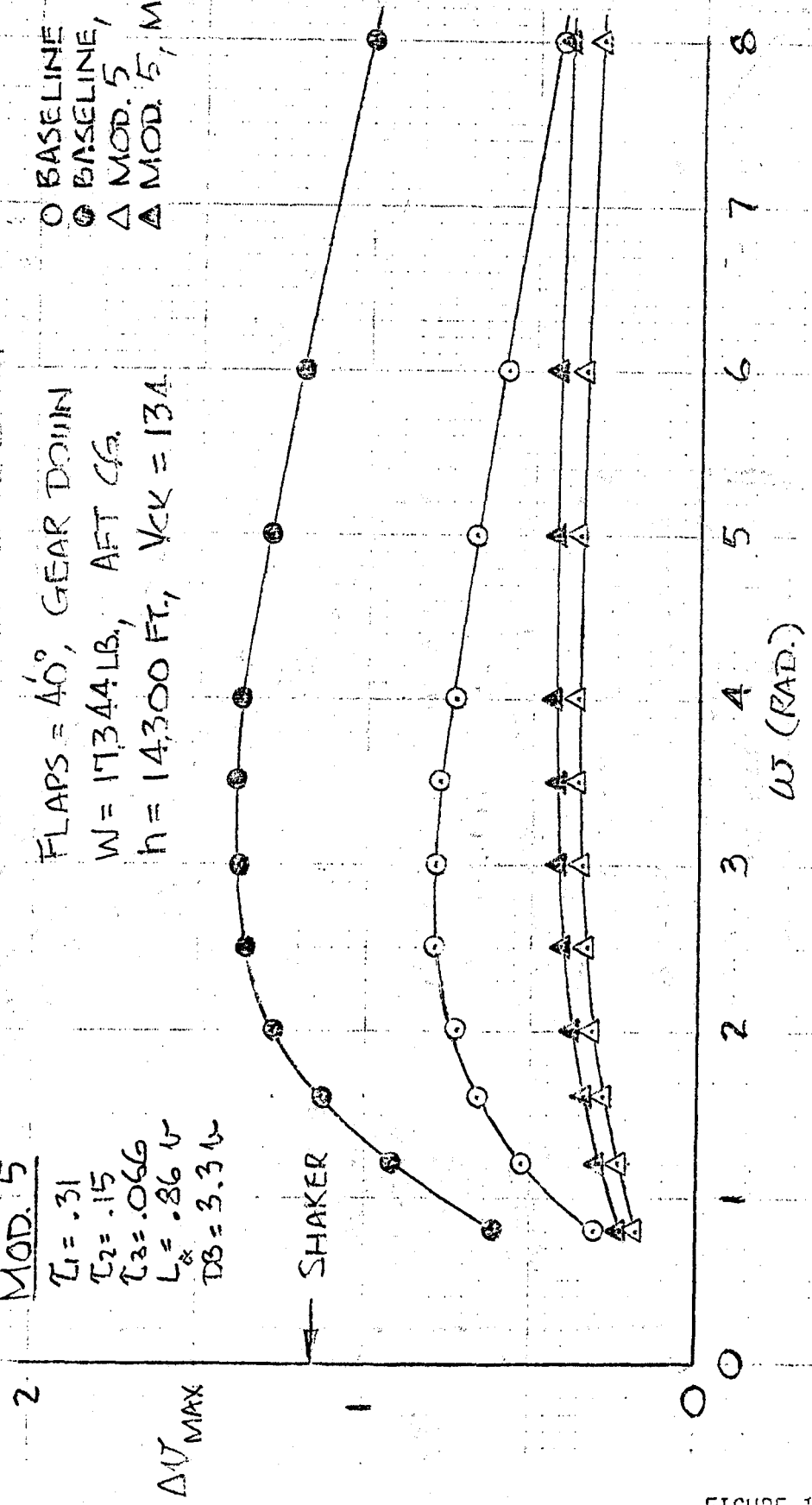

FIGURE 17

FIGURE 18

MODEL 55
 STALL WARNING SYSTEM
 RESPONSE TO RANDOM
 TURBULENCE FOR 20 SEC.

FLAPS = 40°, GEAR/DOWN
 W = 17344 LB., AFT C.G.
 h = 14360 FT., VCK = 134

MOD. 5
 $C_1 = .31$
 $C_2 = .15$
 $C_3 = .066$
 $L\alpha = .86 U$
 $DB = 3.3 U$

- BASELINE
- BASELINE, MAX. TOL.
- △ MOD. 5
- ▲ MOD. 5, MAX. TOL.

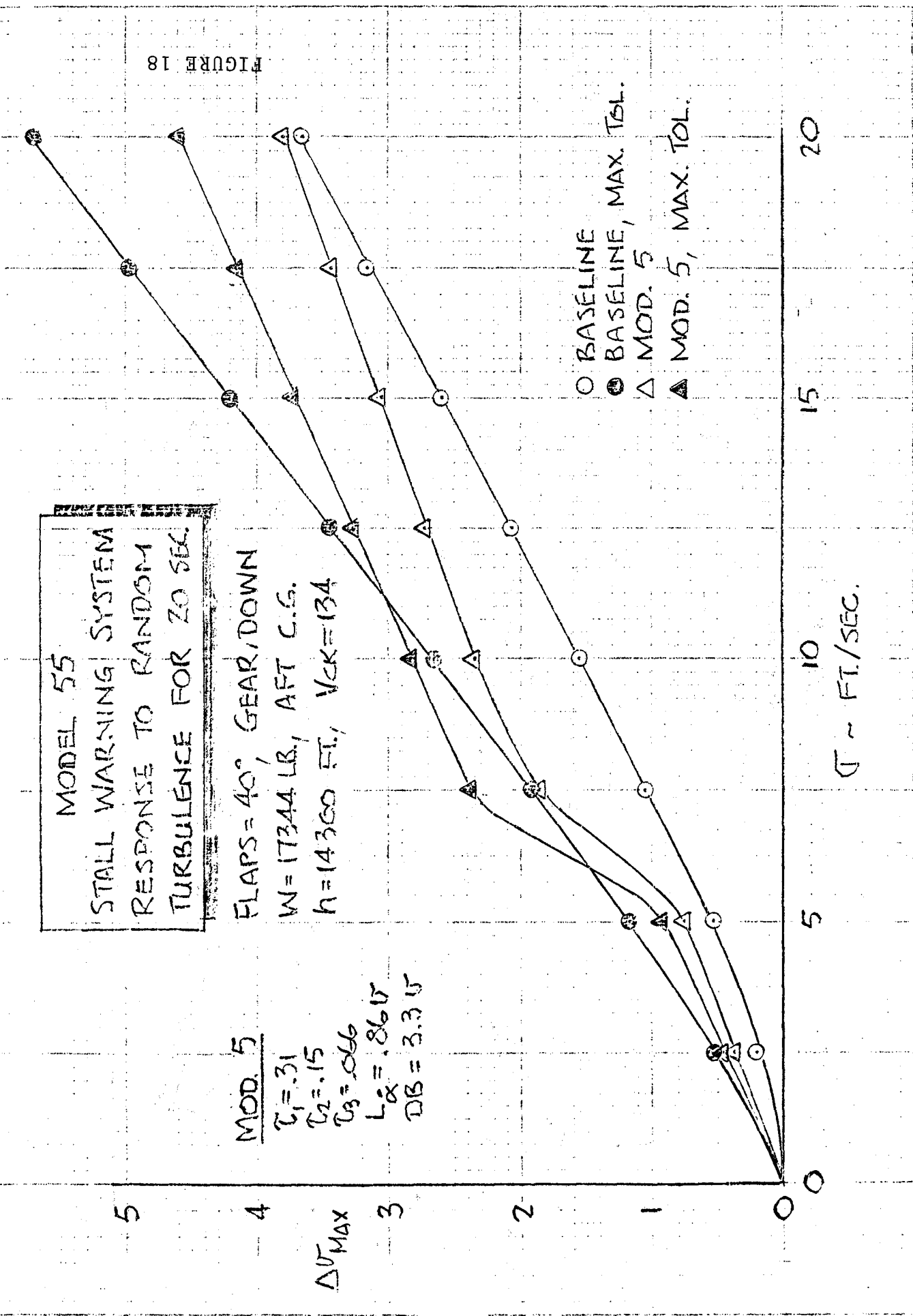

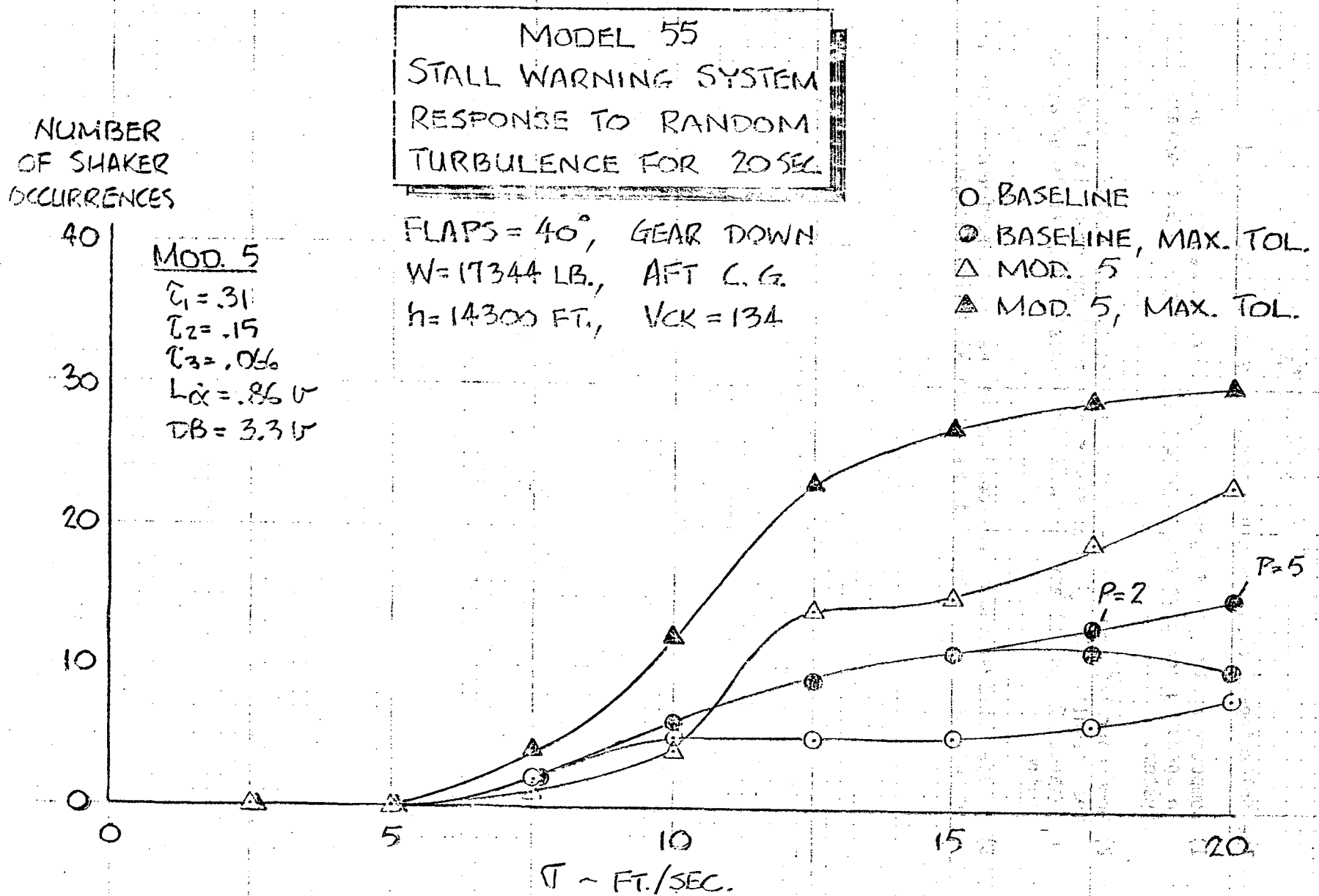

FIGURE 19

IX. CONCLUSIONS

The following conclusions can be drawn from the results of this program:

- 1) Computer analyses and hardware bench tests proved to be valuable in speeding the development of a new stall warning and avoidance system.
- 2) Good correlation was observed between analytical results and flight test results. Analysis of system modifications prior to flight enhanced flight safety during flight tests in high angle of attack regimes.
- 3) A superior system was developed at no penalty in performance or in turbulence sensitivity, and with minimal design changes.