

NASA Contractor Report 3840

NASA-CR-3840 19850007405

Systems Study for an Integrated Digital/Electric Aircraft (IDEA)

**G. E. Tagge, L. A. Irish,
and A. R. Bailey**

**CONTRACT NAS1-17528
JANUARY 1985**

LIBRARY COPY

JAN 21 1985

LANGLEY RESEARCH CENTER
LIBRARY, NASA
HAMPTON, VIRGINIA

NASA

NASA Contractor Report 3840

Systems Study for an Integrated Digital/Electric Aircraft (IDEA)

G. E. Tagge, L. A. Irish,
and A. R. Bailey
Boeing Commercial Airplane Company
Seattle, Washington

Prepared for
Langley Research Center
under Contract NAS1-17528



National Aeronautics
and Space Administration

Scientific and Technical
Information Branch

1985

FOREWORD

This document constitutes the final report of the Integrated Digital/Electric Aircraft (IDEA) Program, Contract NAS1-17528.

The major study objectives were to define the configuration of an IDEA aircraft, define technical risks associated with the IDEA systems concepts, and identify the research and development required to reduce these risks for potential application to transport aircraft in the early 1990s.

The NASA Technical Representative for this task was Cary R. Spitzer; the Contracting Officer was James Y. Taylor, of the Langley Research Center.

The work was accomplished within the Preliminary Design Department of the Boeing Commercial Airplane Company. Key personnel who contributed were:

G. E. Tagge	Program Manager
L. A. Irish	Study Manager
J. D. Vachal	Aerodynamics Technology
L. A. Ostrom	Aerodynamics Technology
R. H. Johnson	Propulsion Technology
G. G. Redfield	Propulsion Technology
A. R. Bailey	Weights Technology
K. E. Siedentopf	Weights Technology
D. L. Grande	Structures Technology
C. B. Crumb	Electronic Flight Control Design
F. Byford	Mechanical Flight Control Design
W. F. Shivitz	Flight Systems Technology
C. W. Lee	Flight Systems Technology
P. J. Campbell	Flight Systems Technology
J. W. Harper	Airframe Systems Technology-Electrical
K. T. Tanemura	Airframe Systems Technology-ECS
E. C. Lim	Airframe Systems Technology-ECS
R. A. Johnson	Airframe Systems Technology-ECS
D. E. Cozby	Airframe Systems Technology-Icing
J. R. Palmer	Airframe Systems Technology-Icing
J. N. Funk	Flight Deck Development
T. A. Pfaff	Flight Systems Flight Deck Research

Appreciation is extended to the following engine contractors and equipment suppliers who made significant contributions to this study:

AiResearch	Lear Siegler
BFGoodrich	Moog Aircraft Controls
E-Systems	Plessey Dynamics
General Electric(OH)	Pratt and Whitney
General Electric(NY)	Simmonds Precision
Goodyear Aerospace	Sundstrand
Hamilton Standard	Sperry
Honeywell	Western Gear
Hydraulic Units, Inc.	Westinghouse

Use of trade names or names of manufacturers does not constitute an endorsement, expressed or implied, by the National Aeronautics and Space Administration.

CONTENTS

Section		Page
1.0	SUMMARY	1
2.0	INTRODUCTION	5
	2.1 Objectives	5
	2.2 Ground Rules and Assumptions	6
	2.3 Approach	8
	2.4 Report Scope	10
3.0	SYMBOLS AND ABBREVIATIONS	11
4.0	BASELINE CONFIGURATION	17
	4.1 Airplane Selection	17
	4.1.1 Selection Criteria	17
	4.1.2 Selected Baseline Aircraft	17
	4.1.3 Baseline Configuration	18
	4.2 Airplane Update	19
	4.2.1 Propulsion	19
	4.2.2 Aerodynamics	20
	4.2.3 Structures	20
	4.2.4 Weight Analysis	22
	4.3 Systems Update	25
	4.3.1 Flight Control	25
	4.3.2 Secondary Power	32
	4.3.3 Avionics	33
	4.3.4 Flight Deck	38
	4.3.5 Environmental Control System	38
	4.3.6 Ice Protection	42
	4.4 Airplane Performance and Economics	43
	4.4.1 Performance	43
	4.4.2 Baseline Configuration Economics	45
5.0	IDEA CONFIGURATION	46
	5.1 General	46
	5.2 Flight Control System	48
	5.2.1 Approach	48
	5.2.2 Supplier Studies	51
	5.2.3 FCS Computer Architectures	59
	5.2.4 Digital Control Signaling	72
	5.2.5 Avionics Integration	77
	5.2.6 Surface Actuation Requirements	78
	5.2.7 Reliability and Dispatch Estimates	80
	5.2.8 Conclusions	82
	5.3 Actuation	83
	5.3.1 Study Emphasis	83
	5.3.2 Discussion	83
	5.3.3 Establishing Requirements	84
	5.3.4 "Smart" Actuator Architecture	86
	5.3.5 Supplier Studies	89
	5.3.6 Actuation Risk Areas	92

CONTENTS (Continued)

	Page
5.4 Electrical System	95
5.4.1 Study Objectives	95
5.4.2 System Selection	96
5.4.3 Alternate Power Distribution – Flight Control Subsystem	102
5.4.4 Configuration Summary	104
5.5 Data Distribution and Avionics System	105
5.5.1 Study Approach	105
5.5.2 Data Transfer Requirements	106
5.5.3 Data Distribution Qualitative Screening	107
5.5.4 IDEA Impacts	111
5.5.5 Selected System	117
5.5.6 Study Comments	122
5.6 Flight Deck System	125
5.6.1 Approach	125
5.6.2 IDEA System Operation	125
5.6.3 General Flight Deck Design Considerations	125
5.6.4 Fly-by-Wire Flight Controls	129
5.6.5 Flight Deck Integration	131
5.7 Environmental Control System	135
5.7.1 ECS Study Cycle Configurations	135
5.7.2 Equipment Configurations	136
5.7.3 Performance Comparison	138
5.7.4 ECS Configuration Selection and Description	144
5.8 Ice Protection System Selection	147
5.8.1 Objective	147
5.8.2 Selection Criteria	147
5.8.3 System Options	147
5.8.4 System Description	151
5.8.5 System Advantages, Disadvantages, and Risk Considerations	152
5.9 Weight, Performance, and Economics	155
5.9.1 Weight	155
5.9.2 Airplane Performance	159
5.9.3 IDEA Configuration Economics	160
6.0 ALTERNATE IDEA CONFIGURATION	167
6.1 Airplane Performance	169
6.2 Ice Protection	171
6.3 Alternate and IDEA DOC Comparison	173
7.0 CONFIGURATION COMPARISONS	175
7.1 Airplane Performance	175
8.0 RESEARCH RECOMMENDATIONS	179
8.1 Research Summary	181
8.2 Digital/Electric Flight–Critical Flight Control	183
8.2.1 IDEA Research Tasks	183
8.2.2 Other Research Tasks	185
8.2.3 Recommended NASA Activity	185

CONTENTS (Continued)

	Page
8.3	Electric Actuation 187
8.3.1	IDEA Research Tasks 187
8.3.2	Other Research Tasks 188
8.3.3	Recommended NASA Activity 189
8.4	Electric Secondary Power System 191
8.4.1	IDEA Research Tasks 191
8.4.2	Other Research Tasks 193
8.4.3	Recommended NASA Activity 194
8.5	Digital Data Distribution 195
8.5.1	IDEA Research Tasks 195
8.5.2	Other Research Tasks 196
8.5.3	Recommended NASA Activity 196
8.6	Digital Avionics System Architecture 197
8.6.1	IDEA Research Tasks 197
8.6.2	Other Research Tasks 199
8.6.3	Recommended NASA Activity 199
8.7	Advanced Flight Deck 201
8.7.1	IDEA Research Tasks 201
8.7.2	Other Research Tasks 202
8.7.3	Recommended NASA Activity 202
8.8	Electric ECS 203
8.8.1	IDEA Research Tasks 203
8.8.2	Other Research Tasks 203
8.8.3	Recommended NASA Activity 203
8.9	Electric Ice Protection 205
8.9.1	IDEA Research Tasks 205
8.9.2	Other Research Tasks 206
8.9.3	Recommended NASA Activity 206
9.0	CONCLUDING REMARKS 207
10.0	REFERENCES 209

FIGURES

		Page
1	Fuel Burn Comparison (1000-nmi Segment)	2
2	DOC Comparison (1000-nmi Segment)	3
3	IDEA Systems Study Task Flow	8
4	IDEA Study Configurations and Features	9
5	Final ACT Airplane	17
6	Baseline Configuration Summary	18
7	Typical High Pressure Compressor Map	20
8	Baseline Configuration – Structures	21
9	Final ACT Primary Flight Control System Architecture	25
10	Baseline Pitch Control System	28
11	Baseline Lateral Control System	30
12	Baseline Directional Control System	31
13	Baseline Systems	32
14	Baseline Data Distribution and Avionics	33
15	Baseline Provisions for Lightning/EMI Protection	37
16	Baseline Configuration Flight Deck	38
17	Baseline Environmental Control Systems	39
18	Baseline Air Supply System	39
19	Engine and Strut-Mounted Air Supply Components	40
20	Baseline Air-Conditioning Packs Installation	40
21	Baseline Required Bleed Airflow – Normal Operation	41
22	Baseline Airplane Ice Protection System	42
23	Baseline Airplane vs 767-200 Performance Comparison	44
24	Approach to FCS Problem	49
25	Architectural Options	50
26	Strawman Pitch Axis	57
27	Supplier Response to Boeing Strawman	58
28A	Pitch Axis Architecture – Baseline	62
28B	Pitch Axis Architecture – Strawman	62
28C	Pitch Axis Architecture – IDEA	63
29	Selected FCS/FMS Architecture	63
30	Alternate FCS Architecture I	67
31	Alternate FCS Architecture II	68

FIGURES (Continued)

	Page
32	Estimated LRU Weight Vs MCU 71
33	Digital Control Bus/RTU Architecture 74
34	FMC ARINC 429 Data Bus Interconnects 76
35	Critical Function Reliability Model 81
36	What Was Accomplished? 83
37	Simplified Block Diagram 84
38	"Smart" Actuator Architecture 86
39	Electromechanical Actuator (EMA) 90
40	Electrohydrostatic Actuator (EHA) 91
41	Options 96
42	Electrical System Schematic 97
43	Dual-Monitored Power Conditioner 98
44	Generator Capacity 101
45	Electrical Equipment Locations 102
46	Data Distribution Options 107
47	New Signal Interface Circuit Locations 112
48	Power Switching and Circuit Protection Location 112
49	Remote Unit Functions 114
50	Data Distribution Overview 117
51	System Organization Groundrules 119
52	Flight Deck and Forward Area Detail 120
53	Avionics Bay Detail 120
54	Midbody and Wing Area Detail 121
55	Aft-Body Area Detail 121
56	CDU Multifunction Keyboard 132
57	ECS Study Compressor Configurations 137
58	ECS Pressure Requirements 138
59	ECS Cabin Cooling Requirements – Standard Day 139
60	ECS Cabin Cooling Requirements – Hot Day 140
61	Representative Compressor Map – Study Configuration 1 141
62	ECS Power Requirements 143
63	Selected ECS System – Study Configuration 1 145
64	Air Conditioning Pack Schematic – Study Configuration 1 146
65	Electro-Impulse System 151

FIGURES (Continued)

		Page
66	IDEA Configuration Center-of-Gravity Limits	158
67	Cost/Benefit Analysis	161
68	Alternate Configuration	167
69	Alternate Configuration Areas of Study	171
70	Block Fuel, Block Time Comparison	176
71	Fuel Efficiency Comparison	176
72	Takeoff Field Length and Range Comparison	177
73	Digital/Electric Flight-Critical Flight Control Research Objective .	183
74	Electric Actuation Research Objective	187
75	Electric Secondary Power System Research Objective	191
76	Digital Data Distribution Research Objective	194
77	Digital Avionics System Architecture Research Objective	197
78	Advanced Flight Deck Research Objective	201
79	Electric ECS Research Objective	203
80	Electric Ice Protection Research Objective	205

TABLES

		Page
1	Aerodynamic Characteristics Comparison	21
2	Structural Weight Increments From Final ACT to Baseline Airplane Configuration	22
3	Propulsion and Systems Weight Increments From Final ACT to Baseline Configuration	23
4	Weight Comparison Between 768-107 and Baseline Configuration . .	24
5	Pitch Axis Changes (Final ACT to Baseline)	26
6	Lateral-Directional Changes (Final ACT to Baseline)	26
7	Baseline - Electronic Component Inventory	34
8	Baseline and Final ACT Configuration Performance Comparison . .	43
9	Airplane Direct Operating Cost Baseline	45
10	IDEA-Based Configuration System Characteristics	47
11	Conclusions From Supplier Responses	59
12	IDEA FCS Functional Descriptions	60
13	Comparison of IDEA FCS Architectures	69
14	FCS/FMS LRU Trade Study	70
15	LRU MCU/Weight Summary	72
16	ARINC vs Data Study Comparison	75
17	FBW Analog/DATAC Trade Study	77
18	Actuation Requirements	79
19	Critical FCS Component Failure Rates	82
20	Flight Critical Load Demand	99
21	Utility System Power Demand	100
22	Data Distribution Qualitative Comparison	108
23	New Unit Summary	114
24	Bus Interconnection Summary	118
25	ECS Study Guidelines and Configurations	135
26	ECS Study Comparison Summary	144
27	Ice Protection Candidate Systems	148

TABLES (Continued)

	Page
28	Weight and Energy Impacts 148
29	Electro-Impulse System Advantages and Disadvantages 152
30	System Technical Risks 152
31	Weight Summary – IDEA Baseline Vs IDEA-Based Systems 155
32	Systems Delta Weight Details 156
33	Weight Summary Major System Changes. 156
34	Weight Comparison 157
35	Baseline and IDEA Configuration Performance Comparison 159
36	Direct Operating Cost Comparison – Baseline vs IDEA. 160
37	Cost Benefit Analysis Summary – Flight Control and Actuation 163
38	Cost Benefit Analysis Summary – Electrical System 163
39	Cost Benefit Analysis Summary – Data Distribution 164
40	Cost Benefit Analysis Summary – Avionics and Flight Deck 164
41	Cost Benefit Analysis Summary – Environmental Control System 164
42	Cost Benefit of Baseline Compared to IDEA 165
43	Benefit of IDEA Compared to Baseline (Fuel Price @ \$1.25, \$1.50 and \$1.75/gal) 166
44	IDEA and Alternate Configuration Performance Comparison 169
45	Direct Operating Cost Comparison – IDEA vs Alternate IDEA Configuration 173
46	Performance Comparison Summary 175
47	Recommended NASA Research Activity. 182

1.0 SUMMARY

This report documents the results of a nine-month systems study of concepts pertaining to the Integrated Digital/Electric Aircraft (IDEA), a broad-based investigation of related advanced electrical and digital systems.

The performance and economics of an IDEA airplane and an Alternate IDEA configuration were evaluated to determine the potential benefits of the IDEA concepts and to identify the research and development required for potential application to transport aircraft in the early 1990s.

This study assumed a 1990 airplane "go-ahead" based on technical readiness of:

- Active controls technology
- Energy Efficient Engine (E³) technology
- Advanced supercritical wing technology
- Composite structures technology
- Other technologies certifiable within the intent of FAR, Parts 25 and 36

The IDEA aircraft also included the following additional technology:

- Digital fly-by-wire flight control system with electromechanical actuators and no mechanical backup
- Electrically driven environmental control systems
- No engine bleed for hydraulic or pneumatic power generation
- Electric starting
- Non-hot-air cowl and wing de-icing

To determine the benefits of the digital and electrical systems concepts, configurations based on those IDEA concepts were defined and compared to a baseline configuration. The configuration selected for use as a reference baseline was a modified 767 airplane, developed under Contract NAS1-15325. For the IDEA study this configuration was then modified incrementally to include the 1990 technologies mentioned above. Throughout this report it is referred to as the Baseline configuration or Baseline airplane.

During the development of the various study configurations, major decisions affecting the selection of specific options were based on trade studies and other related study results. For aspects of the study that could not receive lengthy attention, it was often necessary to base decisions on engineering judgements or standard approaches for typical applications. After the Baseline configuration, the IDEA configuration, and the Alternate IDEA configurations were developed, they were compared in terms of economic performance, fuel efficiency, and significant system and airplane configuration characteristics. Figures 1 and 2 show the results of this comparison for reduced fuel burned and direct operating cost (DOC), respectively.

The IDEA configuration resulted in 3% less fuel burned for a 1000 nmi segment than the Baseline configuration at the same payload and range conditions; the corresponding improvement in DOC was 1.8%. In addition, significant economic improvement was apparent when the total operating cost was included.

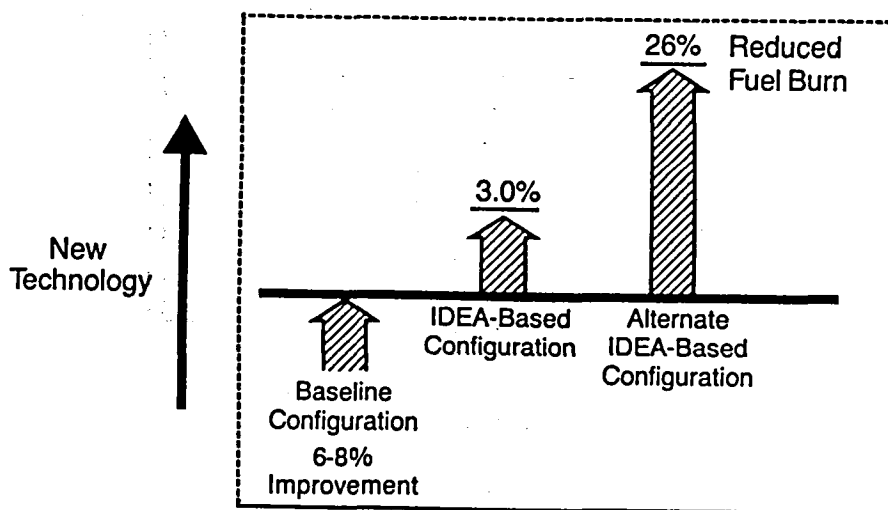

Figure 1. Fuel Burn Comparison (1000-nmi Segment)

The Alternate IDEA configuration, an advanced technology turboprop, resulted in greater potential benefit. Although much of the benefit was due to propulsion technology, it should be noted that the digital-electric systems supported these potential propulsion benefits and increased secondary power system efficiency as well.

Important factors such as weight, reliability, maintainability, cost, performance, survivability, and environmental constraints were analyzed to form the basis for recommending the research and development necessary to implement IDEA concepts. Recommended research programs were defined for high-risk, high-payoff areas appropriate for implementation under NASA leadership.

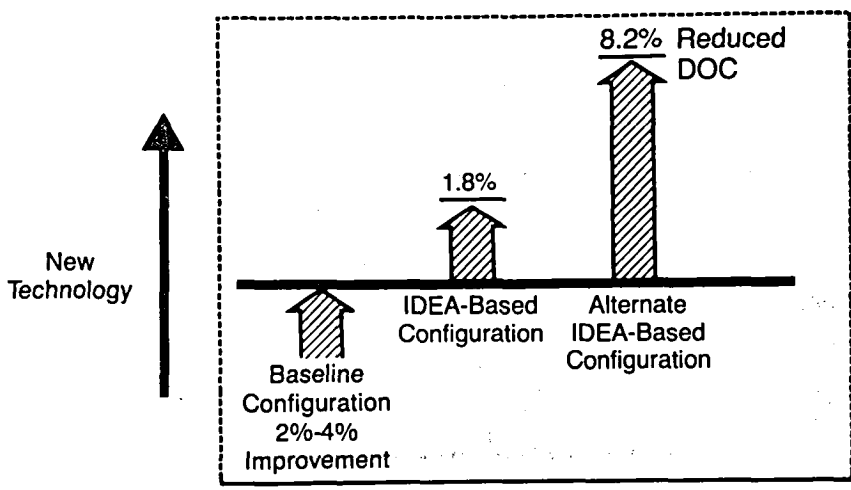

Figure 2. DOC Comparison (1000-nmi Segment)

2.0 INTRODUCTION

During the past decade, NASA-sponsored studies have focused on identifying nascent technologies, applicable to commercial transports, that offer significant performance and efficiency gains. The results of these studies suggest that what is commonly referred to as the "all-electric airplane" offers potential gains in terms of lower direct operating costs, specifically in the areas of acquisition, maintenance, and fuel. The development of all-electric systems, along with their related hardware and software, will require a significant technical and financial investment. Therefore, it is necessary to determine the areas of greatest potential benefit as well as the course to take in developing the required technology.

Several advances in technology have helped to focus attention on all-electric systems research as an area of development appropriate for immediate concentration of effort. For example, the results of recent government and industry programs (ref. 1) indicate that fly-by-wire/power-by-wire (FBW/PBW) systems are viable options for operating the many actuation systems used in high performance airplanes. Significant new technology developments in lighter, smaller electric motors and in digital and high-current, solid-state electronics have provided solid building blocks for these FBW/PBW systems. In addition, studies of alternatives to engine bleed air for secondary power systems (ref. 2) indicate that these systems need not constrain engine selection. Innovative systems development and integration can increase the efficiency of secondary power systems without sacrificing the benefits achieved in advanced energy-efficient engines.

2.1 OBJECTIVES

The main objective of the Integrated Digital/Electric Aircraft (IDEA) study program is the investigation of advanced electrical and digital systems which could be used in aircraft of the near future.

The specific objectives of the IDEA program were:

- Definition of an airplane configuration which incorporated the IDEA systems
- Definition of the technical risks associated with the IDEA systems concepts
- Identification of the research and development activities required to ensure the incorporation of the systems in transport aircraft during the early 1990s

2.2 GROUND RULES AND ASSUMPTIONS

For correct application of the study results, a good understanding of the basic assumptions is essential. The key assumptions, which form the ground rules for the study, are discussed in the following paragraphs.

Time Scale -- In part, the study focused on the interaction of technology advances in different system areas. Historically, the various technologies included in individual systems have advanced at different rates. In order to take advantage of possible synergistic effects it was convenient to assume for this study that technology advances could be brought together in a common airplane at a specific time. The period chosen was the "1990s," with the airplane manufacturer's program go-ahead in 1990 and airline use starting several years later. In order to achieve the 1990 go-ahead, it was assumed that research and development would have progressed to the point that technology could be well demonstrated with minimal risk. It was also assumed that hardware would be available on schedule and within cost, weight, and performance goals.

Research Success -- Three complementary assumptions about future development were made. First, it was assumed that development in active controls, advanced engines, aerodynamics and composite structures, all outside the scope of this study, would have progressed satisfactorily for their incorporation in the Baseline (and IDEA) airplane. Secondly, for the Baseline airplane, it was assumed that the research to be recommended by this study would not be completed by 1990. Only modest improvements to present systems, based on typical development trends and current applications of available

technology, were assumed to be available. Thirdly, for the IDEA systems trade studies, it was assumed that the recommended research would have been successfully completed.

IDEA System Study Directives — Attention was concentrated on system advances and integration by the establishment of certain specific directives, which could be modified for an actual airplane design.

They include:

- All secondary power extraction from the engines is via electrical generators, with no bleed air and no direct shaft power used
- Engine starting is electric
- All actuation is by some type of electromechanical actuator
- All significant computation and data communication is digital

Passenger Accommodations — All present requirements for passenger comfort were maintained at present levels.

Certification — IDEA systems would meet the intent of present certification rules. Where present rules are written in terms of current technological approaches which differ from IDEA technology, it was assumed that equivalent criteria would be developed.

Economics — The IDEA airplane would become operational a decade from now, would be in production for another decade, and would still be flying for a further two decades. No attempt was made to predict economic trends over that time period which might change the relative importance of initial cost, operating cost, weight, fuel consumption and labor. Economic evaluation was based on recent experience and short term projections. It was anticipated that recommended research that presently looks attractive by comparison with this economic model would continue to be worthwhile.

2.3 APPROACH

The sequential tasks of the IDEA systems study are shown on figure 3.

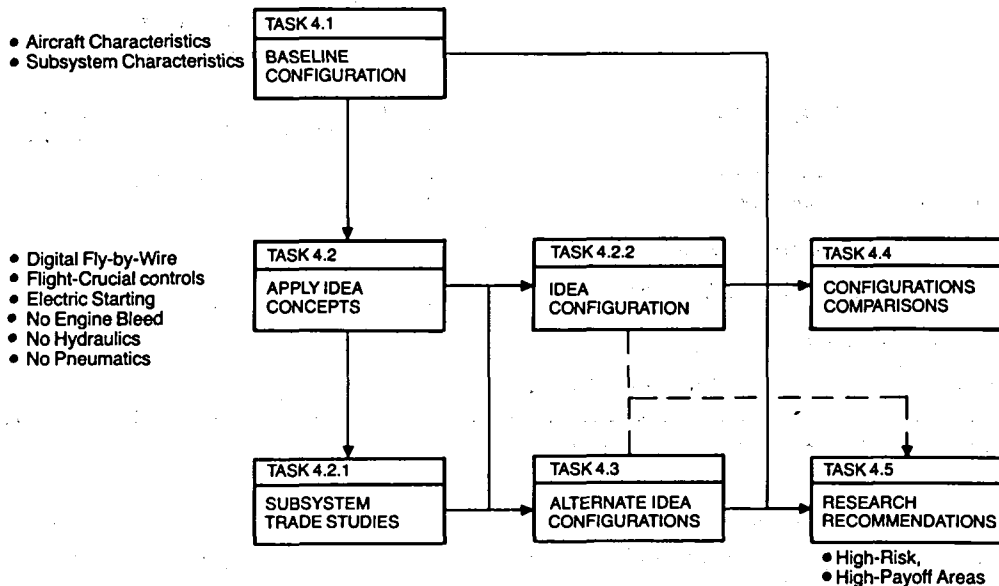

Figure 3. IDEA Systems Study Task Flow

Initially, a Baseline configuration was defined as a reference for subsequent economic and technical comparisons. This configuration was based on a modified 767 configuration with updated technology, included features listed in figure 4, and assumed a 1990 new airplane go-ahead. The Baseline systems were those expected to be used in 1990 if IDEA-related research and development were not accomplished.

The next task was to apply the IDEA concepts and system features, as described in section 1.0 of this document, to the Baseline configuration to develop a new configuration. A series of major subsystem trade studies was conducted in the flight controls, actuation, electrical system, and data distribution technology areas. The preferred subsystem designs were incorporated to establish the IDEA configuration.

Concurrently with the IDEA configuration definition, an alternate, future turboprop configuration was defined and investigated to the extent possible with the contract resources available.

FEATURES *	CONFIGURATION		
	Baseline Airplane	IDEA Airplane	Alternate IDEA Airplane
<ul style="list-style-type: none"> • Active Controls Technology • Energy Efficient Engine (E³) Technology • Advanced Supercritical Wing Technology • Composite Structures Technology • Certifiable Within the Intent of FAR, Parts 25 and 36 	X	X	X
<ul style="list-style-type: none"> • No Engine Bleed for Hydraulic or Pneumatic Power • Electric Starting • Nonhot-Air Cowl and Wing De-Icing • Electrically Driven Environmental Control Systems • Digital Fly-by-Wire Flight Control System With Electromechanical Actuators and No Mechanical Backup 		X	X

* Advanced Technologies Sufficiently Mature for a Transport Go-Ahead by 1990.

Figure 4. IDEA Study Configurations and Features

The IDEA Airplane configurations were "cycled" through a design phase to match the Baseline payload and range. Following this, the necessary data for economic and performance comparison were generated. The IDEA configurations were then compared with the Baseline Airplane in terms of economics, fuel use, and system and configuration characteristics. Finally, the research and development activities required to bring about the selected system advances were identified, and detailed research plans were defined in those areas appropriate for government support.

2.4 REPORT SCOPE

This report contains five major technical sections: 4.0 through 8.0. Each section includes the data for one of the major tasks shown on figure 3.

Section 4.0 describes the Baseline configuration, which was used as a reference for performance and economic comparisons with the IDEA configurations. Selection criteria, technology updates and airplane characteristics are shown.

Section 5.0 describes the development of the IDEA configuration with the features shown on figure 4. Results of subsystem trade studies to select digital/electric system designs are presented. Selected architectures for a flight-critical flight control system and a flight-critical electric secondary power system are shown. The airplane characteristics of the IDEA aircraft, performance and economic data, and comparison with the Baseline are shown. For consistent data, the IDEA configuration was cycled to the same payload and range as the Baseline configuration.

Section 6.0 describes an aft-turboprop alternate configuration. It was defined and investigated to the extent possible with the contract resources available.

Section 7.0 presents the summary data of earlier sections which compare the Baseline configuration to the IDEA configuration and the Alternate IDEA configuration. Differences in aircraft and subsystem characteristics are shown.

Section 8.0 presents an organized set of research programs for high-risk, high-payoff areas appropriate for implementation under NASA leadership.

3.0 SYMBOLS AND ABBREVIATIONS

α	Angle of attack
B	Sideslip angle
δ	Pressure ratio to standard, $\frac{P}{14.696 \text{ PSIA}}$
η	Efficiency
θ	Temperature ratio to standard, $\frac{T}{519^\circ\text{R}}$
λ	Failure rate
ϕ	Roll attitude
A	Amperes
AAI	Angle of attack limiter
ac	Alternating current
AC	Advisory circular
A/C	Air conditioning
ACARS	ARINC Communications Addressing and Reporting System
ACM	Air cycle machine
ACT	Active controls technology
A/D	Analog to digital
Ada	A higher order language (Department of Defense) (The term Ada appears elsewhere in this report. It is recognized that Ada is a registered trademark of the U.S. Government, Ada Joint Program Office.)
ADC	Air data computer
ADF	Automatic direction finder
ADP	Air driven pump
ADV	Advanced
AFC	Automatic flight controls
Ail	Aileron
alt	altitude (same as H)
APU	Auxiliary power unit
AR	Aspect ratio
ARINC	Aeronautical Radio Incorporated
A/T	Autothrottle
c	Speed of light, meters per second
C	Capacitance, Farad
Cat III-B	Category III-B

CAWC	Crew alerting and warning computer
CDU	Control display unit
CFM	Cubic feet per minute -- unit of measure
cg	Center of gravity
C_L	Lift coefficient
CRT	Cathode Ray Tube
CSEU	Control systems electronics unit
CSMA/CA	Carrier sense multiple access with collision avoidance
D	Drag
DADC	Digital air data computer
DATAAC	Digital Autonomous Terminal Access Communication
db	Decibels
DBL	Data base loader
DC	Direct current
deg	Degrees
DEL	Direct electric link
DFDAU	Digital flight data acquisition unit
DME	Distance measuring equipment
DMPC	Dual-monitored power conditioner
E^3	Energy Efficient Engine
ECS	Environmental control system
EEC	Electronic engine controller
EFIS CP	Electronic flight instrument system control panel
EFISG	Electronic flight instrument symbol generator
EHA	Electrohydrostatic actuator
EMA	Electromechanical actuation
EMI	Electromagnetic interference
EMP	Electromagnetic pulse
EPS	Electronics power conditioner
f	Frequency, Hertz
FAA	Federal Aviation Administration
fail-op ²	Dual-failure-operational
fail-op ³	Triple-failure-operational
FAR	Federal Aviation Regulations
FBW	Fly-by-wire
FCC	Flight control computer
FCS	Flight control system

FMS	Flight management system
4D-NAV	Time-based area navigation
ft	Foot
ft lb	Foot pound
Fuel QPU	Fuel quantity processor unit
HOL	Higher order language
hp	Horsepower
HX	Heat exchanger
Hyd	Hydraulic
Hz	Hertz
IAAC	Integrated Applications of Active Controls
ICD	Interface Control Document
IDEA	Integrated Digital/Electric Aircraft
IFCC	Integrated flight control computer
ILS	Instrument landing system
I/O	Input/output
IRAD	Inertial reference/air data unit
kg	Kilogram
kHz	Kilohertz
kVA	Kilovoltamperes
kn	Knots
kW	Kilowatts
L	Lift
L	Inductance, Henry
lb	Pound
LCCA	Lateral central control actuators
L.CDU	Left FMC control display unit
L/D	Lift/drag
Ldg	Landing
L.E.	Leading edge
LNAV	Area navigation
LRU	Line replaceable unit
MAC	Mean aerodynamic chord
Max	Maximum
MCDP	Maintenance control display panel
MCP	Mode control panel
MCU	Modular Concept Unit (ARINC)
M_D	Dive boundary Mach number

MEW	Manufacturer's empty weight
min	Minute
MLC	Maneuver load control
MLS	Microwave landing system
MLW	Maximum landing weight
ms	Millisecond
MTBF	Mean time-between-failures
MTW	Maximum taxi weight
MZFW	Maximum zero fuel weight
N_1	Low pressure rotor of a turbofan engine
N_2	High pressure rotor of a turbofan engine
Nac	Nacelle
NASA	National Aeronautics and Space Administration
nmi	Nautical miles
Nz	Vertical acceleration
OEW	Operational empty weight
PAS	Pitch Augmentation System
Pass	Passengers
PBW	Power by wire
PCU	Power control units
PFC	Pilot flight control remote unit
PFCC	Primary flight control computer
PHX	Primary heat exchanger
PMG	Permanent magnet generator
PRSOV	Pressure regulating and shut-off valve
PSIA	Pounds per square inch absolute
PSID	Pounds per square inch differential
PW	Pratt and Whitney
R&D	Research and Development
RACU	Remote acquisition and control unit
RAT	Ram air turbine
RCCB	Remote control circuit breaker
R.CDU	Right FMC control display unit
RDMI	Radio direction magnetic indicator
r/min	Revolutions per minute
RTCA	Radio Technical Commissions for Aeronautics
RTU	Receiver/transmitter unit (DATAC)

s	Second
SAC	Surface Actuator Computer
SAM	Stabilizer-trim/aileron-lockout module
SAR	Still air range
SAS	Stability augmentation system
SBC	Single board computer
SCR	Silicon controlled rectifier
SFC	Specific fuel consumption
SHX	Secondary heat exchanger
SL	Sea level
SLST	Sea-level static thrust
SSFD	Signal selection-fault detection
STCM	Stabilizer trim control module
Sw	Wing reference area
TAI	Thermal anti-ice
TCAS	Threat Alert Collision Avoidance System
T.E.	Trailing edge
TECS	Total Energy Control System
TOFL	Takeoff field length
TOGW	Takeoff gross weight
TOM	Trim override module
TSFC	Total specific fuel consumption
V	Velocity
V	Voltage, Volts
V_{APP}	Approach velocity
V_D	Dive boundary airspeed
VDC	Volts direct current
VHF	Very high frequency
VNAV	Vertical Navigation
VOR	Very high frequency omnidirectional range
Vrms	Volts root mean square
Vol	Volume
W	Airflow
WLA	Wing load alleviation
Wt	Weight
Z_o	Characteristic impedance, ohms

4.0 BASELINE CONFIGURATION

4.1 AIRPLANE SELECTION

4.1.1 SELECTION CRITERIA

The first task to be accomplished within this study was to identify a Baseline configuration. The criteria used in this selection process incorporated the following: (1) 1990 go-ahead technology including active controls, energy-efficient engines, advanced aerodynamics, and composite structures, all certifiable under FAR Parts 25 and 36; (2) a credible data base, associated with the Baseline configuration, from which weight, performance and cost trades could be made; and (3) a Baseline that would be applicable to IDEA airplane studies.

4.1.2 SELECTED BASELINE AIRCRAFT

The Final ACT airplane, Model 768-107 (fig. 5), was selected to be upgraded to the Baseline configuration and is described in detail in NASA CR 3519 (ref. 3). This aircraft already satisfied many of the technology requirements for the Baseline aircraft, including active controls, critical balance (for example, relaxed stability requiring augmentation devices of flight-critical reliability), and advanced aerodynamics. There also was an excellent data base associated with the Final ACT configuration.

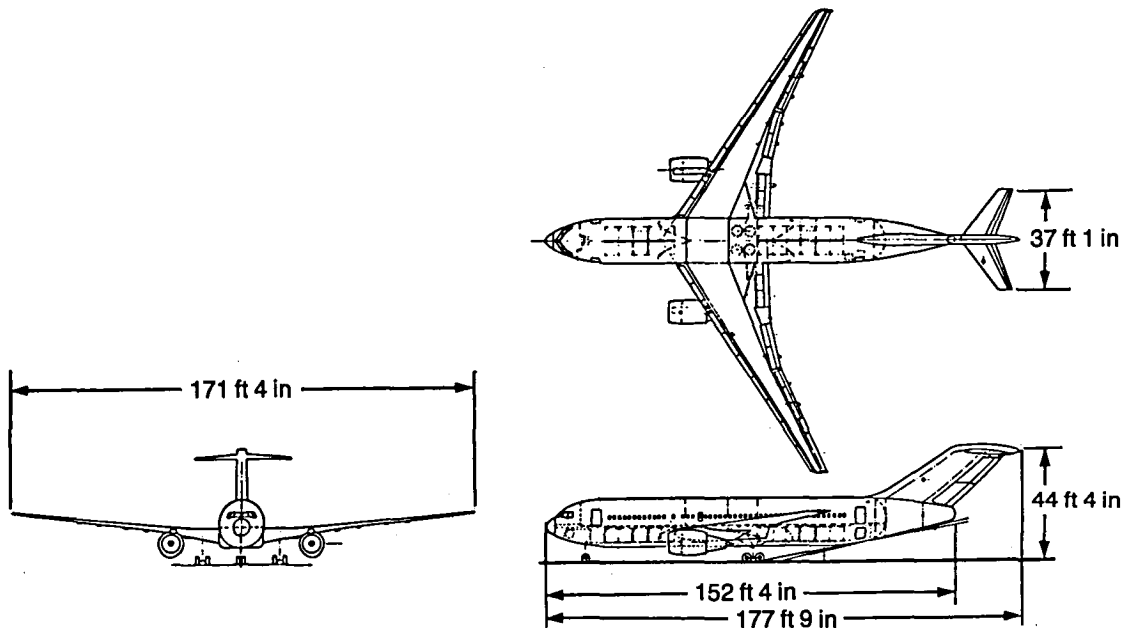

Figure 5. Final ACT Airplane

The airplane in figure 6 illustrates the technology features incorporated into the Baseline configuration. These features are described in detail in the following sections.

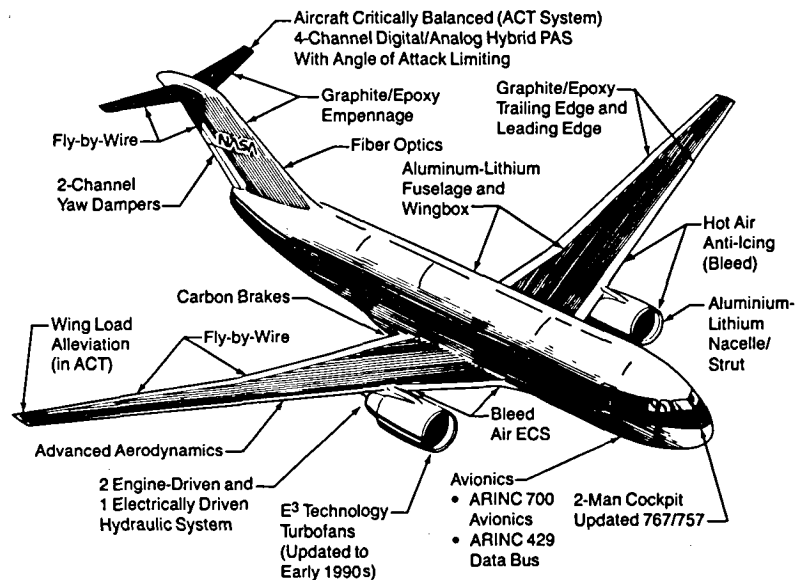

Figure 6. Baseline Configuration Summary

4.1.3 BASELINE CONFIGURATION

In general, modifications were made to update the Final ACT configuration in accordance with predictions of 1990 state-of-the-art conventional transport airplane characteristics. The resulting configuration, referred to as the Baseline Airplane, had the following significant features:

- Fly-by-wire (hybrid analog and digital) with no mechanical paths
- Critical computers are analog, essential computers are digital (using the terms "critical" and "essential" per the FAA definitions)
- Pilot's controls are conventional columns and wheels
- Buses are ARINC 429, single transmitter, one-way
- Dedicated sensor set is provided for critical pitch rate feedback
- Autoflight sensing and computing is separate from the primary FCS and active controls

4.2 AIRPLANE UPDATE

The Final ACT airplane was updated to incorporate the propulsion, aerodynamics, and structural advances specified in the Statement of Work, and the accompanying weight changes were determined.

4.2.1 PROPULSION

The propulsion system selected for the IDEA study was an existing high bypass ratio fan engine that incorporated most of the E³ technology. The engine performance was updated to 1990 technology by factoring total specific fuel consumption (TSFC) and weight according to the manufacturer's recommendation. The manufacturer indicated a further decrease of 1/2% TSFC. This latter improvement resulted from the addition of a compressor stage to decrease work for the individual compressor stages. This addition was necessary to ensure stable operation while extracting high hp at low engine power. The engine also had a low hp extraction penalty compared to other existing turbofan engines. Conversely, its bleed air penalty was significantly higher than most other turbofan engines.

Most turbofan engines are designed for bleed air extraction and relatively small amounts of mechanical power extraction. In the design of an all-electric airplane, it will be important to select or to modify an engine for mechanical power extraction. The use of an engine designed for bleed would cause the acceptance of a higher penalty than necessary. Figure 7 illustrates the efficiency regions of a typical high pressure compressor and shows engine operating lines located to the right and below the peak efficiency islands. With bleed, the operating line tends to move to a lower efficiency region. Power extraction, on the other hand, has the opposite effect, moving the operating line toward higher efficiency. As a further explanation, although stability does not permit the example to become a reality, the operating line could have been located above and to the left of the peak efficiency island. The effects of bleed and horsepower extraction would then be reversed. The operating line of the engine selected for the IDEA study is located to the right and down from peak efficiency, so that when power is extracted the improved compressor efficiency somewhat offsets the penalty incurred.

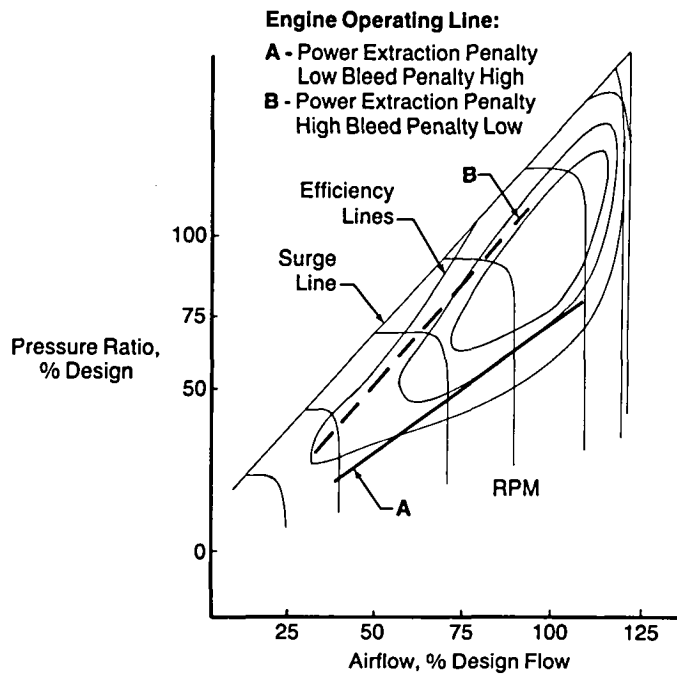

Figure 7. Typical High Pressure Compressor Map

4.2.2 AERODYNAMICS

The aerodynamic characteristics of the Final ACT airplane were based upon preflight test estimates for the 767, with empirical and analytical corrections for small geometric differences between the two airplanes. The cruise drag polars have been improved 3.6% to reflect flight test results (for example, at $M = .80$, $C_L = .45$, L/D has been increased from 19.57 to 20.27, as shown on table 1). Takeoff and landing L/D data were substantiated by flight test results and are unchanged.

4.2.3 STRUCTURES

For the Baseline configuration, the incorporation of advanced structural material of a near-term technology level resulted in estimated weight reduction when compared to the Final ACT configuration.

The proposed application of aluminum-lithium and graphite/epoxy composite for primary and secondary structures, as well as the inclusion of carbon brakes, is illustrated in figure 8. Also illustrated are active controls for wing load alleviation, which were retained from the Final ACT configuration.

Table 1. Aerodynamic Characteristics Comparison

Configuration	Final ACT	Baseline	Δ Percentage
Cruise L/D ($M = 0.8, C_L = 0.45$)	19.57	20.27	+ 3.6
Takeoff Climbout			
$C_{L_{V_2}}$	1.35	1.35	0
L/D_{V_2} (All Engines Operating)	12.4	12.4	0
Landing Approach			
$C_{L_{APP}}(1.3 V_S)$	1.389	1.389	0
L/D_{APP}	8.81	8.81	0

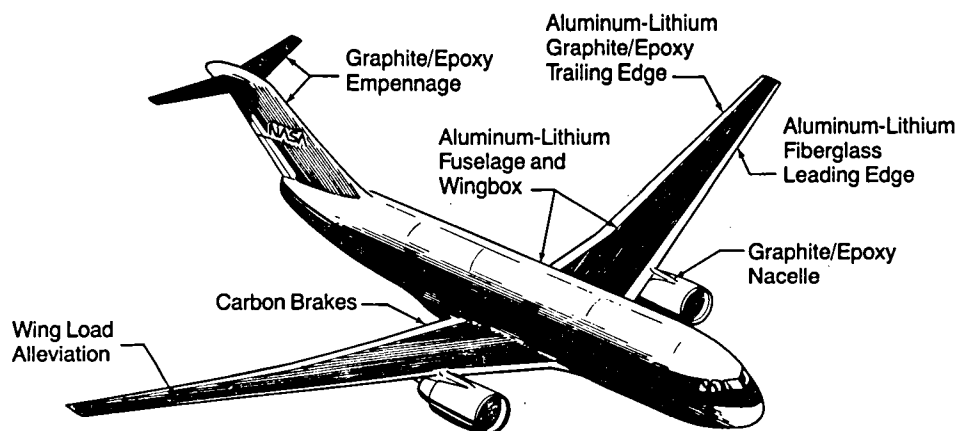

Figure 8. Baseline Configuration — Structures

4.2.4 WEIGHT ANALYSIS

There were three major areas of technology improvement in the Baseline configuration that resulted in an overall weight reduction when compared to the Final ACT configuration.

First, the use of advanced materials is summarized in table 2. The weight increments were calculated on a material substitution basis.

Second, an advanced technology turbofan propulsion system was used. This system utilized 1990's E³ levels of technology. Propulsion system weights were derived using manufacturer-supplied scalars.

Table 2. Structural Weight Increments From Final ACT to Baseline Airplane Configuration

	(Weight in lb)	
Wing		-2,100
Aluminum to Aluminum-Lithium Constructed Wing Box	-1,750	
Aluminum to Aluminum-Lithium Constructed Leading Edge Slats and Trailing Edge Flaps	-350	
Horizontal Tail		-740
Current Technology to all Graphite/Epoxy Composite Construction		
Vertical Tail		-590
Current Technology to all Graphite/Epoxy Composite Construction		
Body		-2,370
Aluminum to Aluminum-Lithium Construction		
Main Landing Gear		- 1,170
Aluminum to Aluminum-Lithium Landing Gear Beam	-220	
Addition of Carbon Brakes With Wheel Change	-950	
Zero Fuel Weight Change (233,670 to 218,230)		-1,150

Third, other systems were updated to a 1990 technology level. Weights were calculated from the appropriate system definition. Table 3 is a summary of the various system weight increments.

A weight statement showing the comparison between Final ACT configuration and the Baseline configuration is contained in table 4. Weight distribution within individual groups is consistent with aerospace industry practice (ref. 4).

Table 3. Propulsion and Systems Weight Increments From Final ACT to Baseline Configuration

	(Weight in lb)
Propulsion System	- 6,580
CF6-6D2 Engines to Advanced Turbofan Engines	
Avionics	+ 260
ARINC Communication Address and Report System	
Microwave Landing System	
Air Traffic Control/Traffic Alert Collision Avoidance	
ECS	
No Weight Change	
Electrical System	- 40
Revise Standby Power System	
Delete 3rd Battery and Charger	
Add 2 Hydraulic-Driven Generators	
Flight Control Systems	- 510
Fly-by-Wire (FBW)	
Fixed Equipment Systems	+ 180
Update Final ACT Component Weights	
Standard and Operational Items	- 630
3-Man to 2-Man Flight Crew	
Unusable Fuel Change	

Table 4. IDEA Program Weight Comparison Between
768-107 and Baseline Configuration

	Final ACT Configuration (lb)	Refined Baseline Configuration (lb)
Wing	37,840	35,310
Horizontal Tail	2,360	1,620
Vertical Tail	4,140	3,550
Body	34,770	2,160
Main Landing Gear	14,280	12,680
Nose Landing Gear	1,970	1,920
Nacelle and Strut	5,610	4,270
Total Structure	100,970	91,510
Engine	17,530	13,000
Engine Accessories	220	270
Engine Controls	180	180
Starting System	170	100
Fuel System	1,320	1,240
Thrust Reverser	3,610	3,000
Total Propulsion System	23,030	17,790
Instruments	1,070	1,450
Surface Controls	4,910	4,400
Hydraulics	2,250	1,970
Pneumatics	780	840
Electrical	2,250	2,610
Electronics	1,710	1,760
Flight Provisions	920	820
Passenger Accommodations	14,730	14,730
Cargo Handling	2,710	2,690
Emergency Equipment	930	1,020
Air Conditioning	2,150	2,280
Anti-Icing	410	250
Auxiliary Power Unit	1,490	1,380
Total Fixed Equipment	36,310	36,200
Exterior Paint	150	150
Options	2,000	2,000
Manufacturer's Empty Weight	162,460	147,650
Standard and Operational Items	3,660	13,030
Operational Empty Weight	176,120	160,680
Passenger Count	(18/179)197	(18/179)197
Engines (Qty/Designation)	2/CF6-6D2	Adv-turbofan
Engine Thrust (SLS)	41,000	38,000
Cargo Containers (Qty/Type)	22/LD-2	22/LD-2
LEMAC = 879.92 in		
MAC = 190.05 in		
Maximum Zero Fuel Weight	233,670	218,230
Maximum Landing Weight	251,670	236,230
Maximum Flight Weight - Flaps Up	268,040	268,040
Maximum Taxi Weight	269,040	269,040

4.3 SYSTEMS UPDATE

Following the definition of the Baseline Airplane configuration, structural concepts, aerodynamics, and engine characteristics, the systems were updated to the 1990s level. In estimating the amount of technological advance necessary to move from the systems of current-generation airplanes to those of the Baseline configuration, a general assumption was made. For most of the Baseline systems, it was assumed that the research required to develop the IDEA configuration would not have been performed and that airframe manufacturers would be slightly conservative, refining only where sufficient data encouraged change.

4.3.1 FLIGHT CONTROL

The Baseline primary flight control system is derived from the Final ACT primary flight control system, figure 9, and features fly-by-wire (FBW) with no mechanical backup. Reference 3 provides a detailed description of the Final ACT control system.

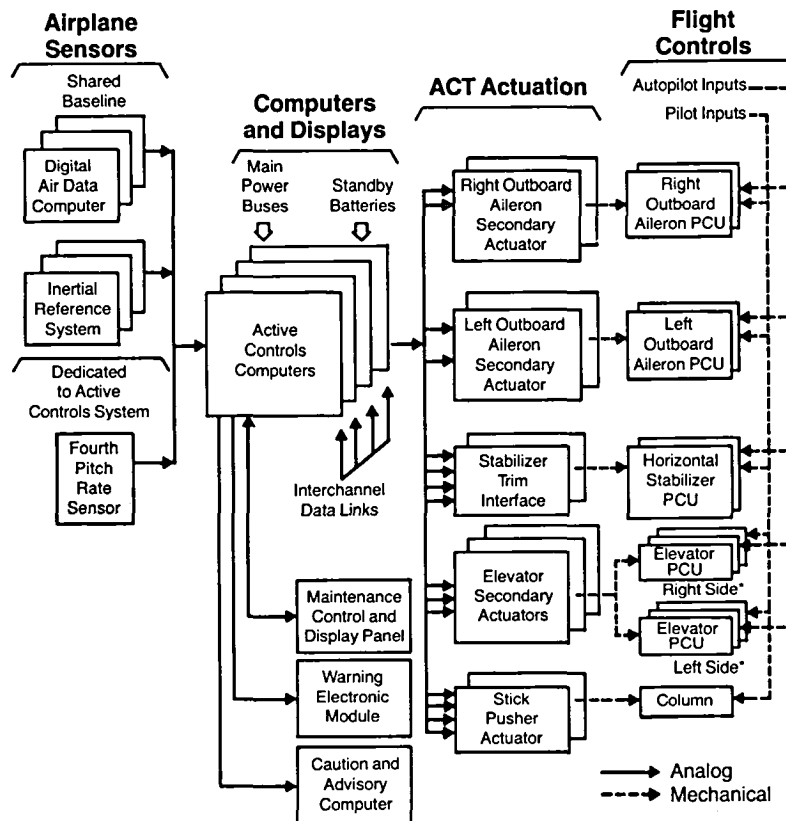

Figure 9. Final ACT Primary Flight Control System Architecture

The changes from the Final ACT to the Baseline configuration are listed in tables 5 and 6. The tables show the addition of four ACT critical computers, three additional pitch rate gyros, and eight secondary actuators. These additions provide a quadruplex analog "brickwalled" implementation for flight critical functions. The term "brickwalled," as used here, refers to the channels being totally separated, operating independently. The

Table 5. Pitch Axis Changes (Final ACT to Baseline)

ADDITIONS	DELETIONS
Secondary Actuator - 1	Mechanical Cables
Trim Override Module - 2	Tension Regulator - 2
Simple Fixed Feel System - 1	Feel and Centering Unit - 1
Pitch Rate Gyros - 3	Feel Computer - 1
Column Force Transducers - 8	Neutral Shift Mechanism - 1
ACT Critical Manual Control Function - 4	Stabilizer Trim Computer - 2
ACT Essential Trim Control Function - 4	Power Supply Module - 4
	Autopilot Secondary Actuators - 3
	Stick Pusher System
	Autopilot CWS Force Transducers - 2

Table 6. Lateral-Directional Changes (Final ACT to Baseline)

ADDITIONS	DELETIONS
Control Wheel Position Sensor - 8	Mechanical Cables; Aileron and Rudder
ACT Critical Manual Control Function (Inboard and Outboard Aileron and Spoilers) - 4	Lateral Central Control Actuator - 3
Inboard Aileron Secondary Actuator - 4	Spoiler Control Module - 7
ACT Essential Manual Control Function (Rudder) - 4	Rollout Guidance Secondary Actuator - 3
Pedal Position Sensor - 8	Yaw Damper Servos - 2
Rudder Secondary Actuator - 3	Rudder Ratio Changer Servos - 2
	Rudder Ratio Changer Module - 2
	Yaw Damper Computer - 2
	CSEU Spoiler LVDTs - 6
	Autopilot CWS Force Transducers - 2

trim override module (TOM) on the stabilizer trim allows the pilot to override a generic software failure or a trim runaway. Deletion of the mechanical controls, the control systems electronic unit (CSEU) and its secondary actuators, the stick pusher, and the autopilot actuators allows a substantial simplification in flight controls installation and rigging, as well as a weight reduction. The resulting Baseline control system is illustrated in figures 10, 11, and 12 as three individual control axis diagrams.

The two fundamental changes between Final ACT and the Baseline are (1) the physical separation of critical and essential functions (per the FAA definitions of "critical" and "essential"), assigning the two categories of functions to two separate redundant computer sets; and (2) inclusion of three-axis fly-by-wire in the Baseline. These changes were judged to bring the Baseline up to what might be called "1990 conventional control system" form.

In the Baseline primary flight control system, all critical functions are implemented in four computers, as are all essential functions. These eight computers, referred to as "critical computers" and "essential computers," meet the necessary levels of reliability for critical and essential functions as prescribed by FAA definitions. Control authority of the essential computers is limited by the critical computers.

The four essential computers are used to improve dispatch reliability. Since dutch roll damping is low and yaw damping is required for limiting structural loads, the yaw damping function has the dispatch constraint of a restricted flight envelope. Stabilizer trim control is dispatch constrained since its absence would require the pilot to carry control column force throughout the flight.

4.3.1.1 Pitch Axis (fig. 10)

The final ACT system used a mechanical pilot input path and a series mode implementation of the ACT pitch augmentation system (PAS) function. Functional partitioning was used to separate essential and critical functions. The quad computers drove a triplex force-summed secondary actuator set, which series-summed with pilot and autopilot inputs to drive the power control units (PCUs). A single point failure (torque tube jam) would cause loss of the PAS function.

In developing the Baseline configuration, it was assumed that the generic software failure problem would still be an unresolved issue. This assumption, along with the concept of complete physical separation to preclude propagation of a failure from the essential to the critical functions, led to separate critical and essential computers. The four critical computers are all analog, full authority and totally verifiable and validatable. The four essential computers are digital, have limited authority, and provide incremental elevator commands to achieve level 1 flying qualities throughout the flight envelope. To achieve a reliability of $< 10^{-9}$ failures per flight hour and maintain a simple brickwall (independent-channel) implementation, a fourth secondary actuator has been added. A dedicated set of four pitch rate gyros is provided for the critical PAS function. To

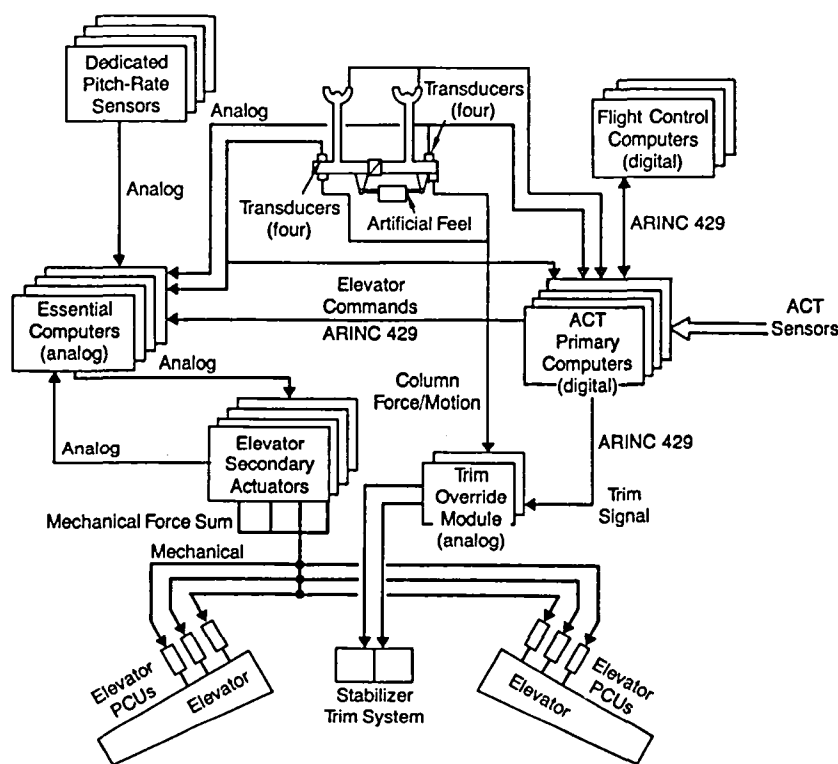

Figure 10. IDEA Baseline Pitch Control System

alleviate the single point failure problem of a jammed torque tube, a shearout between the two pairs of secondary servos is proposed. In the highly unlikely event of a jammed torque tube, control of a single elevator would be lost; however, the other elevator and trim would still be available for control. The force-summed secondary actuator approach is tolerant of hardovers, has adequate resolution and minimizes elevator force fight, and is a low risk approach to critical FBW pitch control. Conventional control column, wheel, and rudder pedals are retained in the Baseline configuration to maintain common type ratings.

In the Baseline, the CSEU functions were deleted and integrated into the critical and essential computers. The stabilizer trim function is integrated into the essential computers. To preclude trim runaway or to counter the effect of generic errors in the stabilizer trim functions, two analog trim override modules are provided (one for each stabilizer trim control module) to allow the trim commands to be overridden from the control column by opposite column force or motion.

The angle-of-attack limiter (AAL) output is sent from the essential computer to the critical computer and then to the secondary servos. The stick pusher has been deleted. The angle-of-attack-driven stick shaker has been retained and will alert the pilot of impending stall. It is driven from the warning electronics unit. The AAL function is considered to be in the essential rather than critical category since the pilot can resort to a restricted flight envelope should total loss of function occur.

The autopilot servos of Final ACT have been deleted. The autopilot computer command is bused to the essential computer, where it is summed with the PAS essential function and the AAL function to serve as an input to the critical computer.

4.3.1.2 Roll Axis (fig. 11)

The Final ACT lateral axis implementation was a manual mechanical control path to the inboard and outboard ailerons from the lateral central control actuators (LCCA). The wing load alleviation system (WLA) utilized the outboard ailerons by means of two force summed secondary actuators whose output was series summed with the manual control linkage outboard of the aileron lockout actuator. The Final ACT spoilers are fly-by-wire from the CSEU spoiler computers. The FCC outputs drive the LCCA to provide a parallel autopilot implementation. Outboard aileron lockout is provided by the stabilizer-trim/aileron-lockout module (SAM) of the CSEU and an electromechanical overcenter actuator.

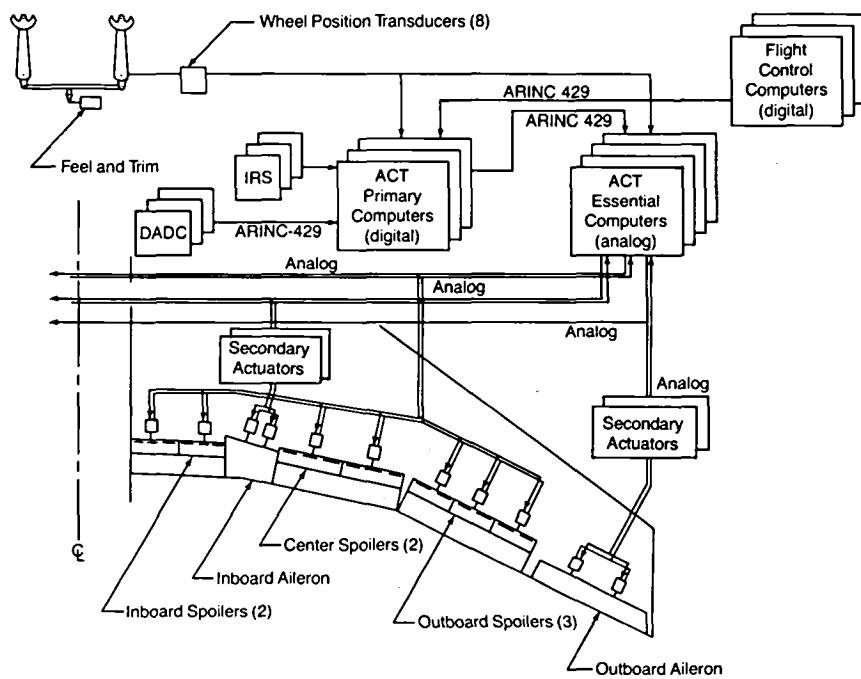

Figure 11. Baseline Lateral Control System

The Baseline roll axis is similar to the pitch axis implementation in that critical functions are analog and essential functions are digital. The manual control of inboard aileron, outboard aileron, and spoilers is functionally partitioned in the critical computers. The inboard and outboard aileron control is achieved by dual electrohydraulic force-summed secondary actuators and two side-by-side hydromechanical power control units (PCU). The spoilers utilize a single electrohydraulic actuator on each spoiler segment. The outboard aileron has balance weights for flutter stability. The WLA function is provided in the essential computer. The WLA inputs, FCC outputs, and manual control incremental inputs are summed and bused on an ARINC 429 bus to the ACT critical computers. The four essential computers are limited authority digital.

4.3.1.3 Yaw Axis (fig. 12)

The Final ACT yaw axis implementation was a manual mechanical control path through the rudder ratio changer mechanism, series summed with the yaw damper secondary actuators, ending at the input to the rudder PCUs. Each of the two rudders, upper and lower, were powered by two single PCUs.

The Baseline essential yaw axis is FBW with rudder pedal position transducers providing position commands to the essential yaw functions, implemented in both the critical and essential computers. The essential computers provide incremental manual commands and yaw damping, and are summed with the autopilot outputs and bused to the critical computers. The critical computer uses the pedal position and the essential computer output to provide input commands to the force-summed secondary actuators. The torque tube output provides a separate mechanical input path for the upper and lower rudder PCUs. The surfaces are not flutter critical.

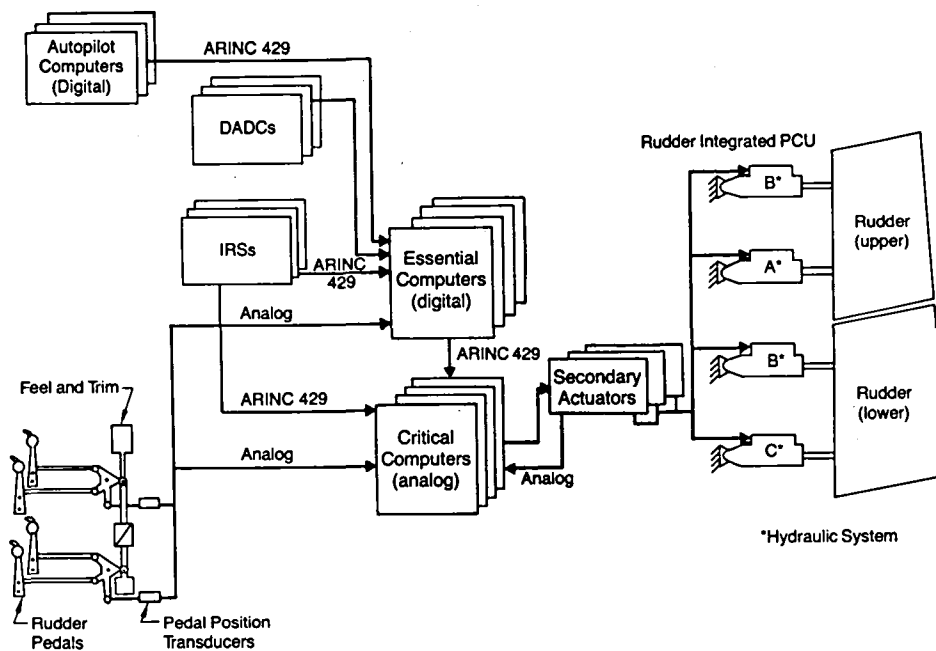

Figure 12. Baseline Directional Control System

4.3.2 SECONDARY POWER

In addition to the components illustrated in figure 13, the Baseline secondary power system includes a bleed air supply system for ECS, anti-ice, and engine starting. These systems are described in sections 4.3.5 and 4.3.6.

The hydraulic and electrical systems are shown schematically in figure 13.

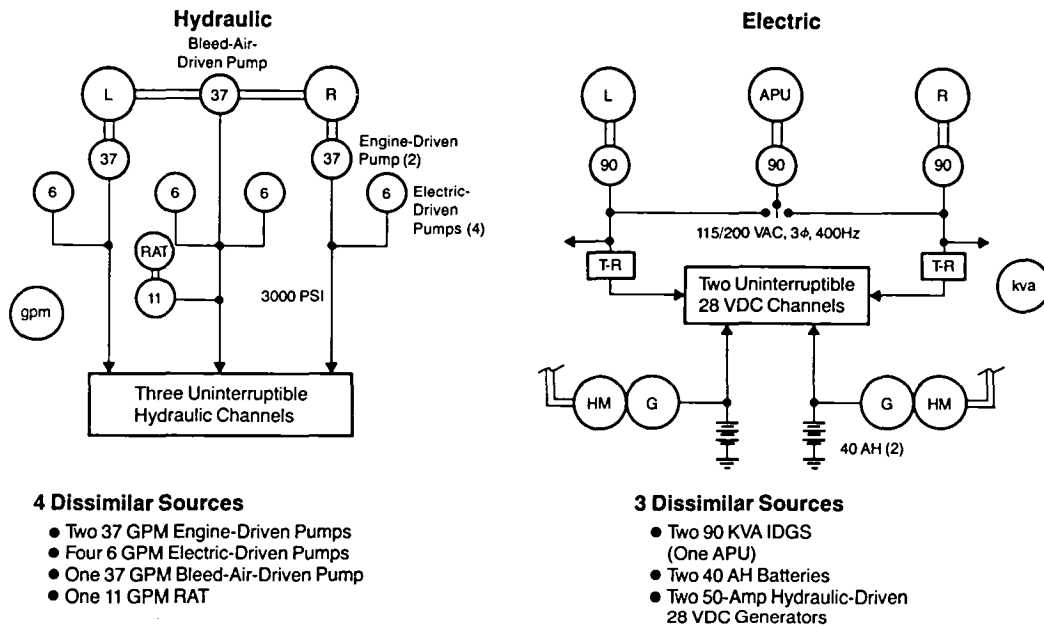

Figure 13. Baseline Systems

The hydraulic system provides three uninterruptible channels to power the flight-critical control surface actuators and other loads. In the event of losing all primary sources, a ram air turbine (RAT) is deployed to provide flight control actuator power.

The electrical system provides two uninterruptible channels, in addition to the primary 115/200 VAC, 3 ϕ 400 Hz power, to power the flight-critical control electronics. In order to minimize dependence on batteries and still provide an uninterruptible power source for these channels after loss of the primary generator sources, two

hydraulically-driven generators are included. One is driven from the left hydraulic system and the other from the center system where the RAT can be used in the all-engines-out case.

4.3.3 AVIONICS

The Baseline configuration key characteristics are shown in figure 14. The avionics technology and data signaling characteristics were unchanged from the Final ACT airplane. Changes were made to the Final ACT airplane to add new system capabilities and to provide lightning protection for the all-composite tail structure change.

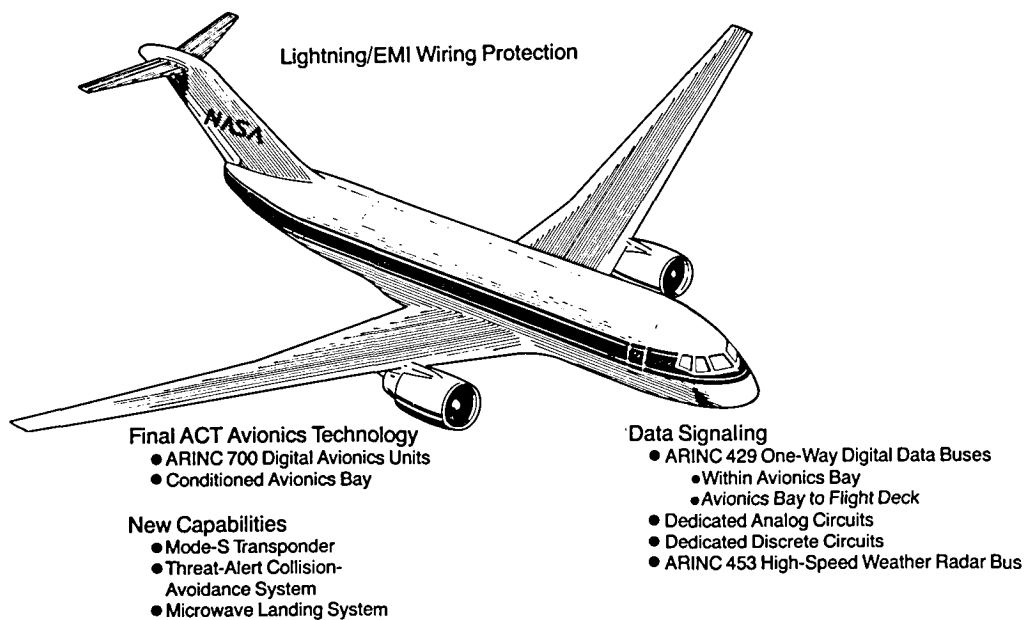

Figure 14. Baseline Data Distribution and Avionics

The Baseline avionics capabilities were upgraded by the addition of systems which are currently being actively considered by government and industry committees: a microwave landing system (MLS), a MODE-S transponder (data link capability) and a threat alert collision avoidance system (TCAS). The optional (Final ACT) ARINC communications addressing and reporting system (ACARS) was also included in the Baseline configuration. The resulting inventory of major avionic subsystems is presented in table 7.

Table 7. Baseline-Electronic Component Inventory

<u>Subsystem</u>	<u>Element</u>	<u>Number</u>
Automatic Direction Finder	ADF Receiver	1
	ADF Control Panel	1
	ADF Antenna	1
Air Data System	Altimeters	2
	Mach/Airspeed Indicators	2
	Vertical Speed Indicators	2
	Standby Altimeter	1
	Standby Airspeed Indicator	1
	Air Data Computer	3
	AOA Sensor	3
Distance Measuring Equipment	Total Air Temperature Sensor	3
	DME Interrogators	2
Electronic Flight Instruments System	DME Antennas	2
	Remote Light Sensors	2
	EFIS Control Panel	2
	EADI Indicators	2
	EHSI Indicators	2
	EFIS Symbol Generators	3
Engine Indicating and Crew Alerting System	EICAS Display Units	2
	EICAS Display Select Panel	1
	EICAS Computers	2
	Cancel/Recall Switch Unit	1
Ground Proximity Warning System	Ground Proximity Override Switch	1
	Ground Proximity Warning Computer	1
Instrument Landing System	Localizer Antennas	2
	ILS Control Panel	1
	ILS Receivers	3
	Glideslope Antennas	2
Inertial Reference System	IRS Mode Panel	1
	Inertial Reference Units	3
Radio Altimeter	Radio Altimeter Transmit Antennas	3
	Radio Altimeter Transceivers	3
	Radio Altimeter Receive Antennas	3

Table 7. Baseline-Electronic Component Inventory (Continued)

Radio Distance Magnetic Indicators	RDMI Indicators	2
VHF Omnidirectional Range/Marker Beacon	Marker Beacon Indicators	2
	VOR Control Panels	2
	MB Antenna	1
	VOR Antenna	1
	VOR/MB Receivers	2
Warning Electronics Unit	Warning Electronics Unit	1
	Alerting Loudspeaker	2
	Discrete Caution Light Set	1
	Discrete Warning Light Set	1
	Master Warning/Caution Light/Switch	2
	Control Column Stick Shaker	2
ATC Transponder and Traffic Alert	Collision Avoidance System	
	MODE-S/TCAS Control Panel	1
	MODE-S Transponder	2
	TCAS Unit	1
	Message Terminal	1
	Omni Antenna	5
	Directional Antenna	1
Microwave Landing System	MLS Receiver	3
	Remote Amplifier	4
	MLS Control Panel	1
	MLS Antenna	3
Weather Radar	WXR Control Panel	1
	WXR Antenna	1
	WXR Transceiver	1
Miscellaneous	Instrument Source Select Panels	2
	Standby ILS Processor	1
	Standby Attitude/ILS Indicator 1	1
	Standby Engine Indicator	1
	Digital Clock	2
	Standby Compass	1
	Miscellaneous Systems Test Panel	1
Autopilot Flight Director System	Autoland Status Annunciators	2
	Mode Control Panel	1
	Flight Control Computers	3
	Maintenance Control Display panel	1
	Autopilot Disconnect Switch	2
	Autopilot Go Around Switch	2

Table 7. Baseline-Electronic Component Inventory (Concluded)

Flight Management Computer System	Control Display Units	2
	FMC Computers	2
	Data Base Loader	1
Thrust Management System	Thrust Mode Select Panel	1
	Thrust Management Computer	1
	Autothrottle Disconnect Switch	2
VHF Communications	VHF Comm Control Panel	2
	VHF Transceiver	2
	VHF Antenna	2
ARINC Communications and Reporting System	ACARS Control Unit	1
	ACARS Management Unit	1
	Printer	1
SELCAL	SELCAL Decoder	1
	Pilots Call Panel	1
Audio Systems (No Breakdown)	Service Interphone	
	Flight Interphone	
	Passenger Address	
	Passenger Service	
Flight Data Recording System	Digital Flight Data Acquisition Unit	1
	Digital Flight Data Recorder	1
	Flight Recorder Control Panel	1
	Three Axis Accelerometer	1
Cockpit Voice Recorder	Voice Recorder	1
	Voice Recorder Control Panel	1

In order to define the Baseline in the time available, several assumptions had to be made about the new systems. The MLS configuration was based on the ILS installation. The Baseline would have both ILS and MLS autoland capability. Remote signal amplifiers were used to boost the RF signal. The MODE-S/TCAS installation included a modified ATC transponder control panel and an undefined crew terminal installation. It was assumed that the TCAS warning alerts and advisories were routed through the crew alerting system. Time critical formats were displayed on EFIS. These assumptions were used to define weight and equipment count estimates.

The inclusion of an all-composite tail was a significant structural change in the Baseline configuration. This change impacted avionics systems by its effect on lightning/EMI vulnerability. The limited Baseline definition effort called out guidelines to improve lightning/EMI immunity. These provisions are illustrated in figure 15. Some of these callouts protect against direct physical affects. To protect critical components in the tail or those interconnected via wiring routed through the tail, a policy of shielding and hardening was adopted. In an actual production airplane program much validation, modeling and verification work would be required to ensure the adequacy of the design provisions.

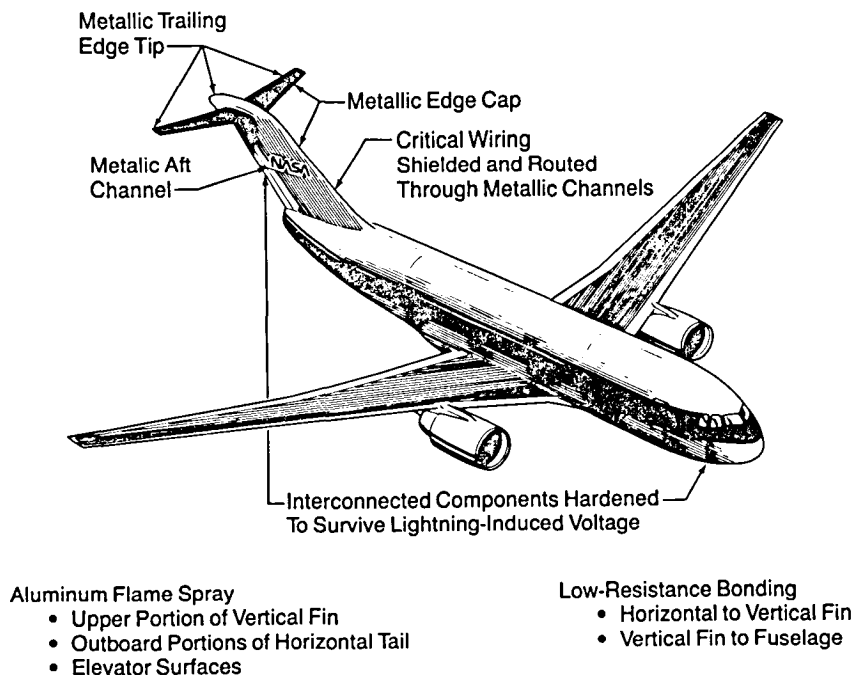

Figure 15. Baseline Provisions for Lightning/EMI Protection

4.3.4 FLIGHT DECK

The Final ACT airplane was originally designed for a three-man crew. For the Baseline configuration, the flight deck was upgraded to a two-man crew configuration based on recent production experience. The key changes were the elimination of the flight engineer's station and the change to an integrated engine-indicating and crew-alerting system. Other flight deck characteristics were unchanged. Figure 16 illustrates characteristics of the Baseline configuration flight deck.

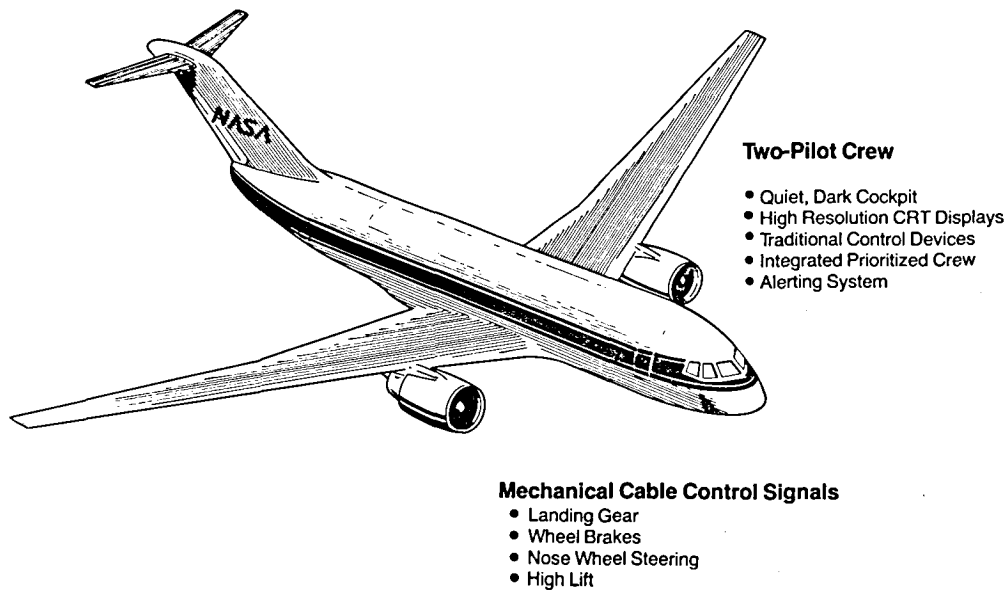

Figure 16. Baseline Configuration Flight Deck

4.3.5 ENVIRONMENTAL CONTROL SYSTEM

General study configurations for the environmental control systems of the Baseline Airplane are shown in figure 17. Air for inflight operation is supplied by the main engines. Intermediate-stage and high-stage bleed air is precooled with engine fan air and is pressure-regulated before being ducted from the wing-mounted engines to the body-mounted air-conditioning packs. Air for ground operation is supplied by an auxiliary power unit installed in the tailcone of the Baseline airplane. Baseline ECS air sources, ducting and control are illustrated in figure 18. Figure 19 depicts engine bleed air extraction, precooling, and pressure and flow control components.

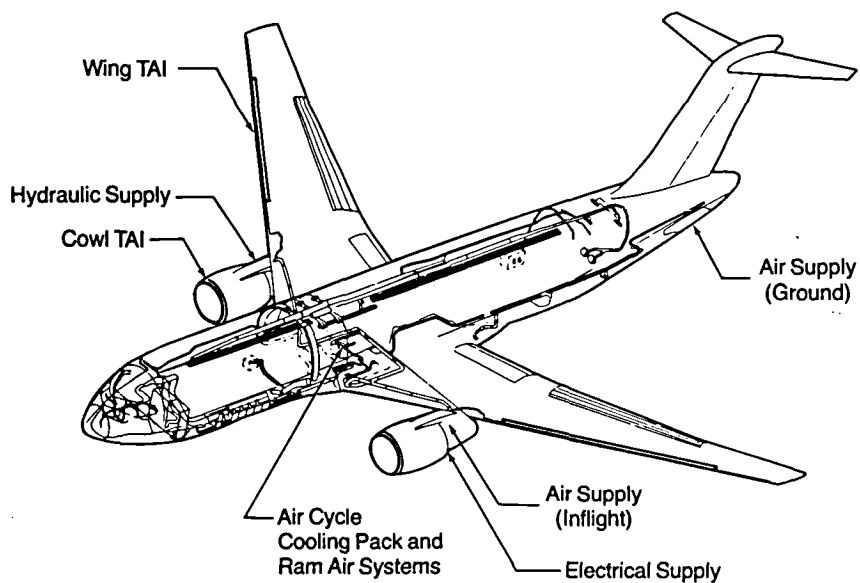

Figure 17. Baseline Environmental Control Systems

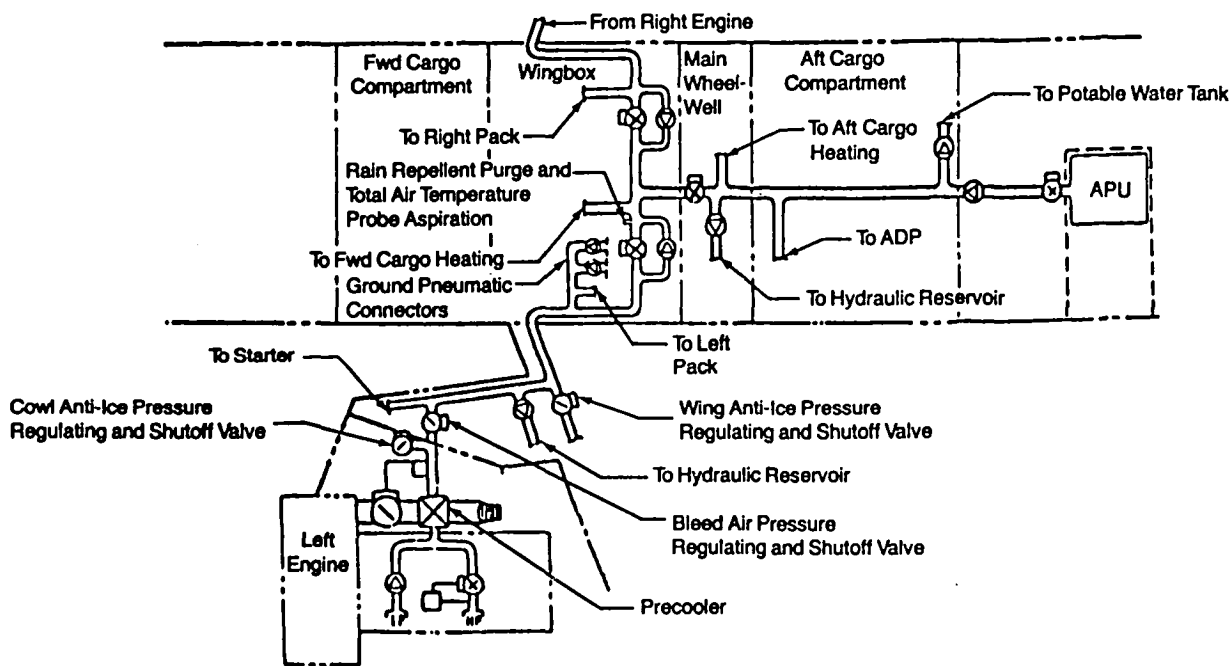

Figure 18. Baseline Air Supply System

Thermal conditioning of the air supplied to the flight deck, cabin and equipment cooling systems is accomplished by two air cycle packs located beneath the wing box in the body of the Baseline Airplane. Heat sink for pack cooling operation is provided by ram air collected from the wing-to-body fairing area of the aircraft. Refer to figure 20 for an illustration of the equipment.

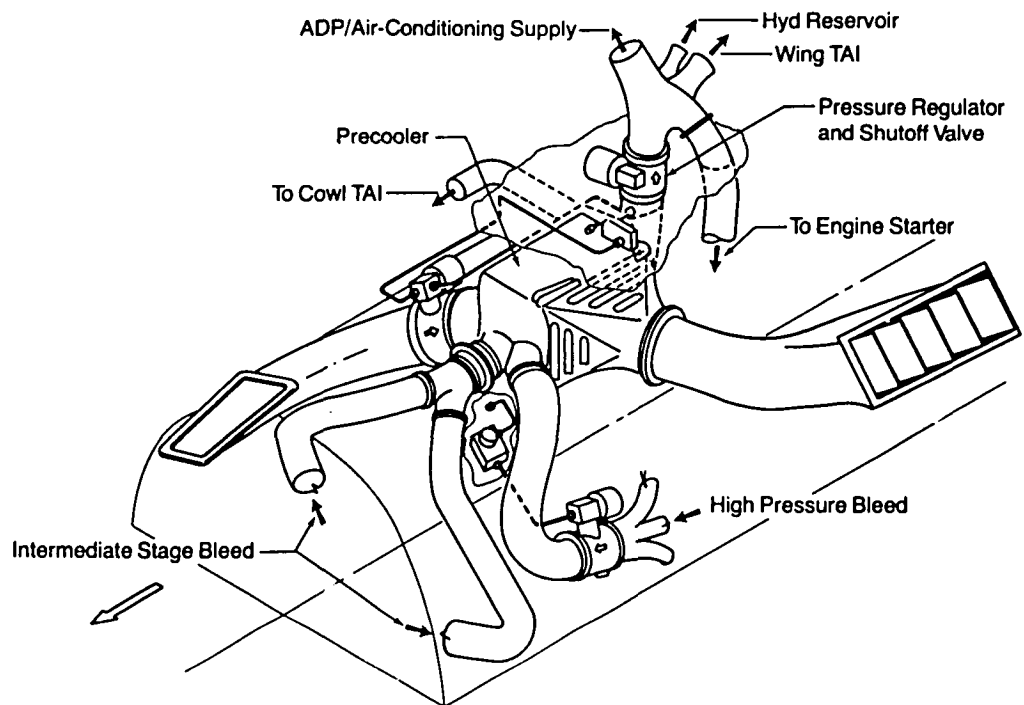

Figure 19. Engine and Strut-Mounted Air Supply Components

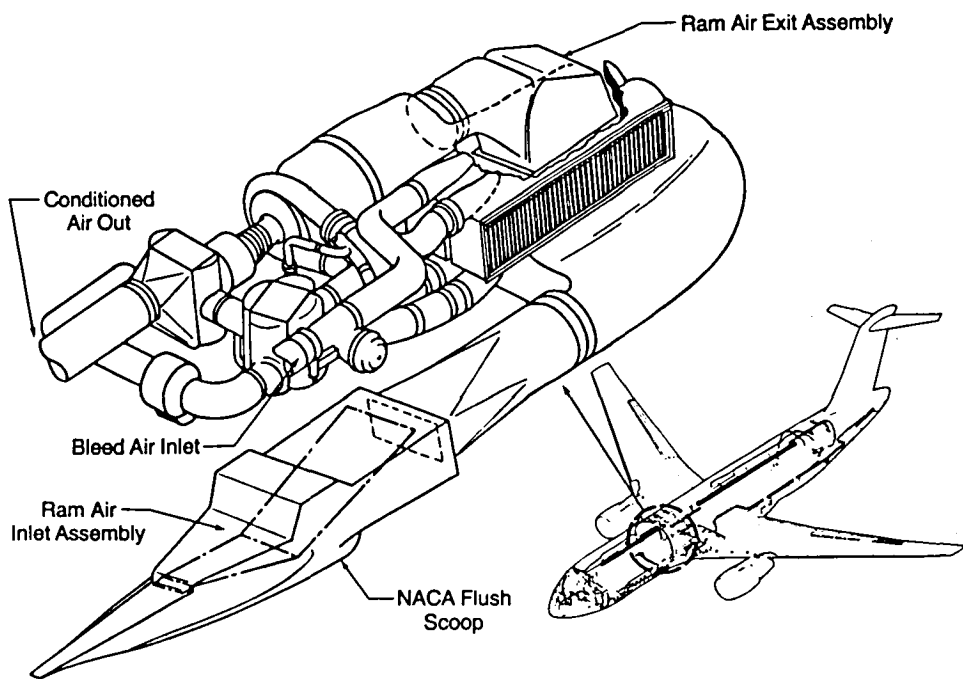

Figure 20. Baseline Air-Conditioning Packs Installation

Cabin air conditioning performance requirements for the Baseline and IDEA study configurations are identical. A 75°F cabin temperature with a nominal cabin pressure differential of 8.6 PSID is maintained. Cabin ventilation is accomplished with a minimum fresh airflow of 10 CFM per occupant with 50% recirculated airflow. Required engine bleed airflow for normal operation is shown in figure 21 for three operating conditions.

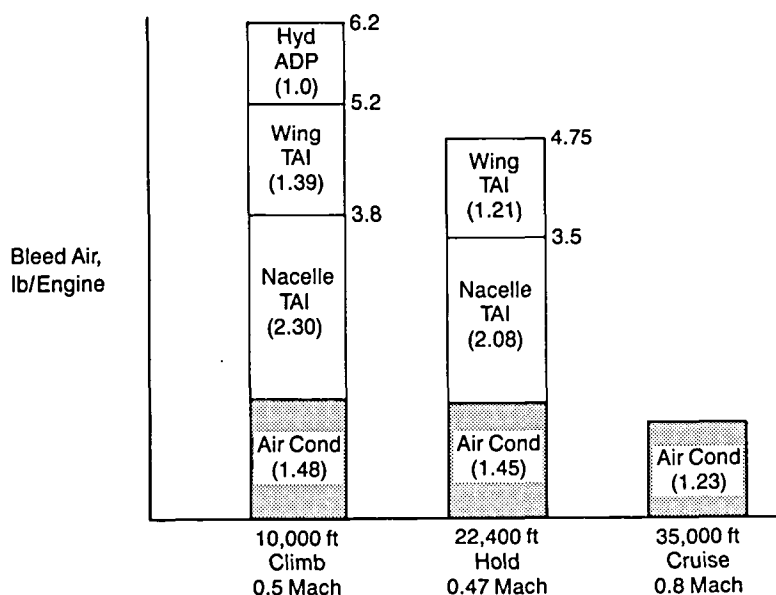

Figure 21. Baseline Required Bleed Airflow—Normal Operation

The wing anti-ice system uses pressure regulated, precooled bleed air ducted to a piccolo tube in the wing leading edge. This high temperature air impinges on the leading edge and is exhausted through ports on the lower surface of the leading edge. The system is analyzed and sized to provide a "running wet" surface (i.e., impinging water flows beyond the heated zone) during maximum icing design conditions. During these conditions, runback water tends to form ice ridges along the wing, aft of the leading edge, that cause drag by disrupting airflow. For this reason, as well as to reduce energy consumption, the recommended mode of operation is to leave the anti-ice system off and then de-ice the wing immediately following an icing encounter.

The ice detector shown in figure 22 is used as an advisory indicator.

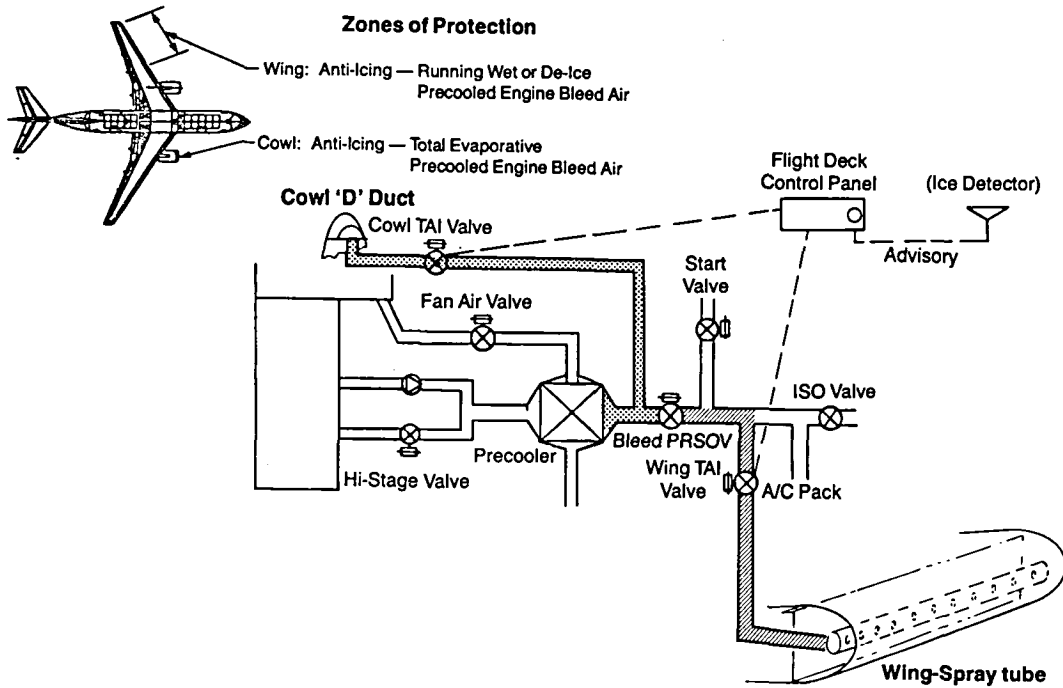

Figure 22. Baseline Airplane Ice Protection System

4.3.6 ICE PROTECTION

The Baseline Airplane has a pneumatic thermal anti-ice system for both cowl and wing, using engine bleed air as the source of hot air (fig. 22).

For the cowl anti-ice system, the precooled engine bleed air is ducted to the cowl spray tube located in the cowl leading edge. This high temperature air impinges upon the leading edge of the cowl and is exhausted aft of the impingement zone. The system is analyzed and sized to provide enough heat for a totally evaporative surface (i.e., all impinging water is evaporated in the heated zone). The system is controlled manually by the flight crew.

4.4 AIRPLANE PERFORMANCE AND ECONOMICS

4.4.1 PERFORMANCE

After retaining the takeoff gross weight, passenger payload, and wing areas of the Final ACT configuration and introducing the various changes which led to the Baseline configuration, the resulting range and other performance parameters were determined. These are shown in table 8. The two major performance changes between the Baseline and the Final ACT were the increase in range (4,006 nmi vs 1,938 nmi) and the reduction in fuel burn per passenger (29.5% at 500-nmi range). These changes were due mainly to the reduction in cruise specific fuel consumption and operational empty weight.

Table 8. Baseline and Final ACT Configuration Performance Comparison

- 197 Passengers
- Cruise Mach = 0.80

CONFIGURATION	FINAL ACT	BASELINE	INCREMENT PERCENTAGE
Maximum Brake Release Gross Weight, lb	268,040	268,040	0
Operational Empty Weight, lb	176,120	160,680	-8.8
Sea Level Static Thrust, lb	41,000	38,000	-7.3
Cruise Altitude, ft	39,000	39,000	0
• Lift/Drag	19.3	19.8	+3.0
• Specific Fuel Consumption	0.65	0.54	-16.9
• Range Factor, nmi	13,600	16,800	+23.5
Still Air Range (SAR), nmi	1,938	4,006	+106.7
Takeoff Field Length, ft (SL, 84°F)	6,200	6,630	+6.9
Approach Speed, kn (Max Ldg Wt)	134.2	129.8	-3.3
Block Fuel per Passenger			
• 500 nmi, lb/Passenger	67.5	47.6	-29.5
• 1000 nmi, lb/Passenger	112.7	80.9	-28.2

By way of comparison, the range capability of the Baseline Airplane is about halfway between the current 767-200 and 767-200ER (extended range) airplanes, as shown in figure 23, with comparable takeoff field length and landing approach speed capabilities. Also, as shown on figure 23, the inclusion of more advanced technology than in the current 767 (ACT plus a higher wing aspect ratio, advanced materials and engines) has a very beneficial effect on fuel burn per passenger, about a 25% reduction in total. The fuel burn incremental difference between Final ACT, given in table 8, and the current 767 level, illustrated in figure 23, is due mainly to the improved engines and higher passenger count on the 767.

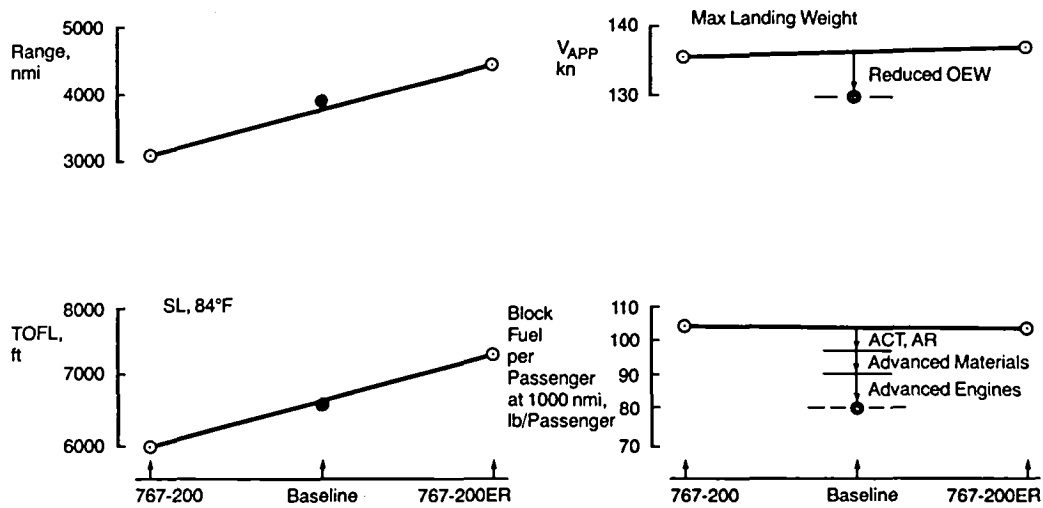

Figure 23. Baseline Airplane vs 767-200 Performance Comparison

4.4.2 BASELINE CONFIGURATION ECONOMICS

The economics of the Baseline Airplane have been determined by the ATA direct operating cost (DOC) method, with updating to the Boeing 1983 coefficients. The U.S. domestic rules were used with an average 500-nmi range for the analysis. The aircraft utilization was based on 2,120 trips per year at the designated range.

Depreciation for both the airplane and engine was based on accepted airline practices for new equipment. Aircraft maintenance costs were based on 1983 prevailing burdened labor rates and material cost. The fuel price was specified at \$1.50 per gallon for all the airplane system analysis studies performed on this contract.

Table 9 summarizes the DOC elements and values for the Baseline Airplane. The economics of the Baseline configuration are compared with those of the IDEA configuration in section 5.9.

Table 9. Direct Operating Cost Baseline

	Baseline
<ul style="list-style-type: none"> • 1983 U.S. Domestic Rules • 500 nmi Range 	
Takeoff Gross Weight (lb)	268,040
Number of Passenger Seats	197
Block Fuel (lb)/(lb/Seat)	9,385/47.6
Depreciation, Airframe and Engine	3.19
Insurance	0.10
Flight Crew	1.45
Fuel (at \$1.50/gal)	4.42
Airframe, Material and Burdened Labor	0.87
Engine Material and Burdened Labor	0.68
DOC (\$M per Year)	10.70
(\$/SM)	8.783
(Cents/ASM)	4.459

5.0 IDEA CONFIGURATION

5.1 GENERAL

The IDEA configuration was developed by incorporating an optimal combination of IDEA concepts into the Baseline configuration. This was accomplished through a set of parallel system trade studies, with continual coordination to assure system compatibility.

In each system area, requirements, constraints, and ground rules were developed to the appropriate level of detail, and system options were assembled. Through trade studies, analysis, and equipment supplier consultation the range of options was progressively narrowed down and details were refined to give the selected system configuration. Primary emphasis was placed on the flight control, actuation, electrical, and data distribution systems. The ECS and ice protection systems were worked to sufficient depth to assure realistic estimates of power demand, weight, and cost. The avionics and flight deck studies drew extensively on NASA IAAC and other research activities, adapting those results to the other systems of the IDEA configuration.

The main features of the selected systems are shown in table 10.

Table 10. IDEA-Based Configuration System Characteristics

Flight Control

- Digital data bus oriented
- Highly integrated computation
- Generic fault avoidance

Actuation

- All electrically powered
- Rotary or linear by application
- Gears or hydraulic by application
- Remote (central) processing; local processing a strong contender

Electrical

- Variable-voltage/variable-frequency utility power
- 270-VDC electronics and actuation power
- Flight-critical power via three multi-source power conditioners
- Flight-critical power from N1 (fan) driven generators plus other dissimilar sources
- Power control by logic-operated switches; no thermal circuit breakers
- 20 kHz alternate electronics and actuation power

Data Distribution and Avionics

- Multi-transmitter autonomous data buses
- Separate redundant bus sets for control, sensor, and management data
- All logic implemented in microprocessors
- Fifteen remote units

Flight Deck

- Outboard or dual wrist controller
- Linked pilot/copilot control motion

ECS

- Air cycle plus heat exchanger cooling
- Electric-powered ram air compressors

Ice Protection

- Electro-impulse
- Automatic operation

5.2 FLIGHT CONTROL SYSTEM

The objective of this portion of the study was to develop an advanced digital flight control system with sufficiently high reliability and performance and sufficiently low cost to serve a future commercial transport airplane. At all times the design was required to reflect the necessity of maintaining operational safety at levels equal to or greater than current levels.

Since the Baseline configuration already incorporated fly-by-wire and active controls technology (ref. section 4.1.3), the principal benefits of the IDEA concept were realized in the secondary power system, actuators, and signal communication. Further integration and use of digital devices in the flight control system seemed appropriate since they could contribute additional benefits by 1) reduction in size, weight, and cost; and 2) improved performance.

Of the trends which will affect the choices available for future FCS design, perhaps the most significant is the trend in microcircuitry development. The trend toward smaller, lighter, faster circuits that require lower power is continuing, and digital computers will reap the full benefits. Single-board computers (SBC) can now be made, and that becomes especially important in going to high levels of redundancy. These changes also point to integration of separate computers by either combining their functions in a single machine or housing separate processors in a single enclosure. Both tactics reduce weight and cost. However, the opportunity for and propriety of such integration is strongly dependent on criticality of functions and the system architecture chosen.

5.2.1 APPROACH

The approach to the definition of the IDEA flight control system began with a careful stipulation of system requirements and design ground rules. In order to select the appropriate architecture for an airplane of the 1990s, it was necessary to project current development trends in technology through an examination of what was currently available and what was currently under research. Further, it was necessary to assume that promising areas of development could be accelerated through increased research and

development to produce applicable benefits within the IDEA time frame. The initial system architecture, referred to as the "Strawman," was responsive to the stipulated rules and requirements and reflected the considered opinions of both the industry and its suppliers. Suppliers' opinions were obtained by submitting the Strawman requirements and ground rules to eight flight control system suppliers with the request that they comment upon the Strawman and show their preferred system configurations and supporting rationale. (Refer to figure 24 for a depiction of the approach.)

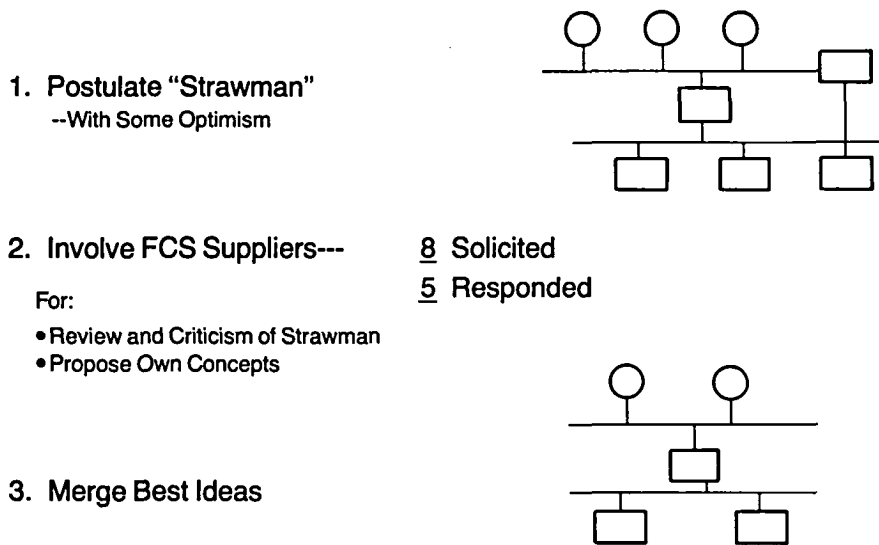

Figure 24. Approach to FCS Problem

The system requirements, design ground rules, and Strawman architecture submitted to the FCS suppliers are listed in section 5.2.2. Upon the return of the vendor comments, their applicable ideas were incorporated to define the FCS system architecture for the IDEA configuration. A number of alternative features were also attractive and warranted definition of several alternative system configurations.

The selection of a control system architecture involved choices between some important sets of options, as illustrated in figure 25. Where the control system uses digital processors, there were especially important alternatives arising from the possibility of the so-called "generic" fault, which may bring down all redundant channels simultaneously. In this study, a system architecture was selected which assumed the ability to prove the nonexistence of such a fault. At present this capability does not exist. However, the related research recommended in section 8.2.1 is aimed at developing it.

Since another objective was systems cost reduction, changes which yielded no cost saving were justified on the basis of improved performance and/or improved overall airplane economics. The changes accepted were deemed certifiable with reasonable effort, and did not compromise safety. The design was also constrained by time; some desirable features require too much development time to be available for a 1990 project go-ahead commitment.

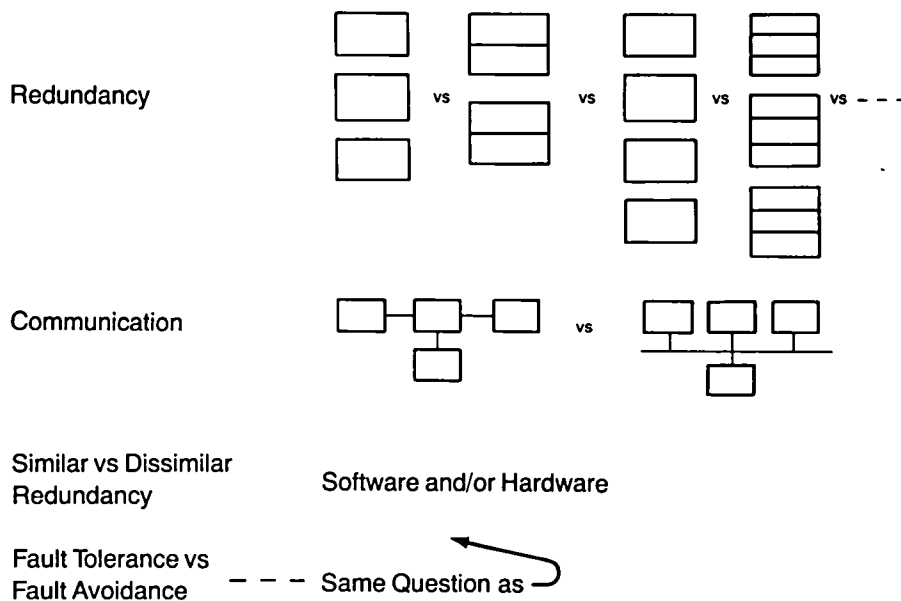

Figure 25. Architectural Options

There are no new functional features in the flight control system design for the IDEA airplane; almost all the advanced features are flying now, at least in military airplanes.

The cost concern is for complete life-cycle cost, including all nonrecurring and recurring costs. Nonrecurring costs include the cost of certification, which was high in some early digital flight control systems. Historically, electronic systems maintenance has been a significant operating cost; engineering the system for easy maintainability and low maintenance requirements must be an objective from the start.

5.2.2 SUPPLIER STUDIES

Section 5.2.2.1 gives the problem statement sent to the suppliers. For comparison, refer to section 4.1.3 for a description of the Baseline FCS.

5.2.2.1 Problem Statement

The balance of this section is quoted from the problem statement sent to eight FCS suppliers.

"Problem Statement

The desired response to this problem statement will be composed of the following:

1. A recommended flight control system architecture and rationale for its choice.
2. A first estimate of the size, weight, and reliability of the line replaceable units (LRU) of the system; and a first estimate of the system cost based upon a quantity of 200 shipsets.
3. Comments upon the Boeing "Strawman" architecture presented here, and especially the supplier's reasons for taking exception to the Boeing concept.

"SYSTEM REQUIREMENTS

a. Functions

The flight control system will mechanize the following functions in the flight critical category:

1. Pitch axis primary flight control
2. Roll axis primary flight control
3. Pitch stability augmentation
4. Category III-B automatic landing

The system will mechanize the following flight control functions in the essential category:

1. Yaw axis primary flight control
2. Longitudinal trim
3. Yaw axis stability augmentation
4. Maneuver load control for alleviation of wing loads
5. Angle-of-attack limiting
6. Normal autopilot modes (with the exception of automatic landing)

Autopilot comprised of:

Control Wheel Steering
Flight Director
Altitude Hold or Select
Vertical Speed
Speed/Mach Hold or Select
VNAV/LNAV including 4D NAV Flight Path
Command from Flight Management
Computer (FMC)
Take-Off (Flight Director Only)
Go-Around

7. Thrust management

The definition of critical and essential functions is in accord with FAA advisory circular 25.1309-1. Critical functions are those whose loss would prevent continued safe flight and landing; their probability of loss must be less than 1×10^{-9} per flight hour. Essential functions are those whose loss would reduce the ability of the flight crew to cope with adverse operating conditions and might require flight diversion or other change in the flight plan; their probability of loss must be less than 1×10^{-5} per flight hour. Angle-of-attack limiting is considered essential because: (a) duty cycle is extremely low; (b) in-flight monitor will warn of function loss; and (c) in case of function loss, pilot can limit flight envelope.

Pages 53-84 missing in original document.

The following are inputs to the actuation system:

- Surface position commands
- Surface rate commands
- Rate limit
- Position limit
- System status

Similarly, outputs from the actuation system:

- Surface position
- Actuator status

5.3.3.2 Actuation System Internal Functions

Within the actuation system itself the following functions are expected to be accommodated:

- Loop closure
- Limiting
- Gain changing
- Calibration (self-rigging)
- Built-in test equipment (BITE)
- Equalization
- Fault detection and compensation
- Status reporting on all of the above

5.3.3.3 Functional Considerations

Design requirements could not be specified before functional considerations associated with the installation, operating environment, and maintenance of a new technology system were also considered.

The following represents some of the potential problem areas that must be addressed for a power-by-wire actuation system:

- Motor/load inertia ratios
- Power supply and/or conditioning for command processing
- Power supply and/or conditioning for motors
- Output synchronization
- Rigging
- Installation (thin surfaces, high aspect ratios, etc.)
- Lightning/EMI

Besides considering the effect of interfaces within the system, the effect of the system on its own environment should be questioned. The effects of high-speed switching of electrical power in the multi-kilowatt range may dictate some difficult shielding and filtering requirements, with special attention to be given to the question of radiation by the power supply bus itself.

5.3.4 "SMART" ACTUATOR ARCHITECTURE

Figure 38 illustrates the organization and functional partitioning of a smart actuator system, which would be one of two or three on an elevator control surface. The number of actuators per surface will depend upon the way the overall control system is configured to handle faults.

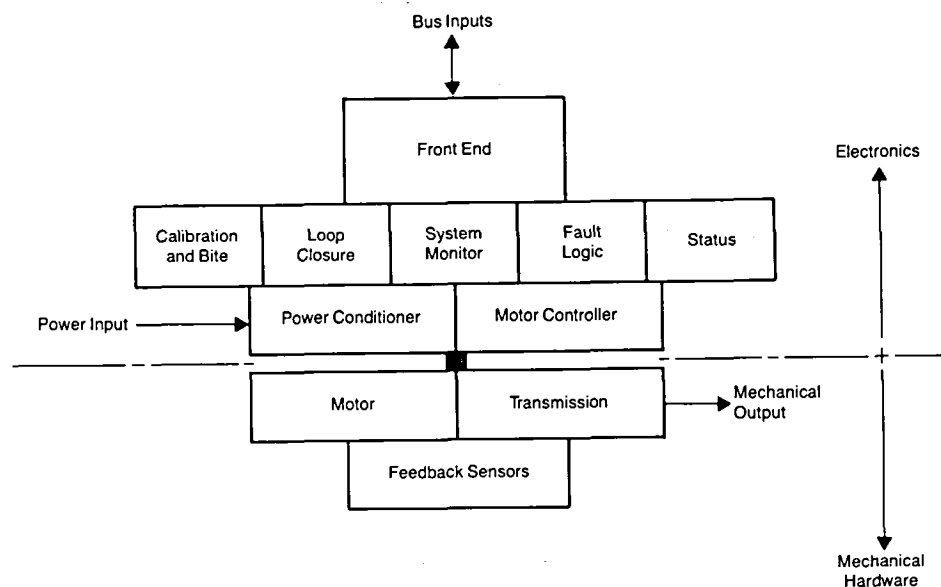

Figure 38. Smart Actuator Architecture

The titles of each of the following brief descriptions refer to individual functions as labeled in figure 38. These functions were the basis of a problem statement sent out to industry for review and consideration.

5.3.4.1 Front End

The front end provides a means of receiving commands, transmitting status, and decoding and coding signals as required.

The configuration of the front end is dependent upon the selection of a data bus system. The bus terminal is expected to be developed as part of the overall data bus development and is not considered as an actuation system problem; however, the power for the terminal is to be included in the power conditioner.

5.3.4.2 Calibration

This function provides a means of eliminating mechanical adjustments and providing inherent synchronization. By adapting the actuator stroke and gain to the mechanical installation, compensation for the tolerance buildups normally encountered in the manufacture of the airplane can be achieved.

5.3.4.3 Built-In Test Equipment (BITE)

The built-in test equipment (BITE) will provide the necessary component and system checks to inform the fault logic and status functions of any anomalies within the actuator.

5.3.4.4 Actuation Loop Closure

In addition to the normal summing of input and feedback signals, gain change instructions can be processed to accommodate the calibration function and flight control computer commands as required.

5.3.4.5 System Monitor

This function monitors the other actuators on the surface being controlled, and compares their performance to the host actuator, providing the results to the fault logic and status functions.

5.3.4.6 Fault Logic

Utilizing the information received from the other functions, determination of the relative value of the actuator to the overall airplane system is made, and the actuator is shut off if necessary.

5.3.4.7 Status

Informing the flight control computers of the actuation system status is the primary task for this function so that the airplane flight control system can be reconfigured if desirable. Two other important tasks performed in this box are cross checking of the fault logic and provision of a backup shutoff command.

5.3.4.8 Power Conditioner

Conversion of the power input into a suitable form for the internal digital electronics and the motor controller may need to be accomplished, depending on the form of power supplied.

Even if the power supplied is close to ideal, some form of protection for both the actuator and the power supply will be needed, along with a means of informing the status and fault functions of a substandard power supply.

5.3.4.9 Motor Controller

This provides motor commands as a function of the error signal provided by the actuator loop closure.

5.3.4.10 Motor

Electrically powered and energy efficient.

5.3.4.11 Transmission

Connection of the motor to the control surface can be accomplished in several different ways, giving enough flexibility to the design of the hardware to suit any particular installation as well as possible.

Requirements for flutter stiffness, damping, and reversibility must be considered.

The transmission could take the form of gears, rollerscrews, hydrostatic actuators, integrated actuator packages, powered hinges, or any mechanical device suitable for the application.

5.3.4.12 Feedback Sensors

Current analog position sensors need to be replaced by absolute digital position sensors. The digital sensors allow simplification of circuitry, which will enable channel matching. Some research is being done in this area. It should be expanded and continued.

5.3.5 SUPPLIER STUDIES

A problem statement was sent to 21 potential suppliers with the projected installation and performance requirements for the elevator, aileron, and rudder actuation systems for the IDEA Airplane.

Technical responses were solicited from the suppliers concerning any or all of the control surface actuation systems, at their option.

The wing anti-ice system uses pressure regulated, precooled bleed air ducted to a "piccolo" tube in the wing leading edge. This high temperature air impinges on the leading edge and is exhausted through ports on the lower surface of the leading edge. The system is analyzed and sized to provide a "running wet" surface (i.e., impinging water flows beyond the heated zone) during maximum-icing design conditions. During these conditions, runback water tends to form ice ridges along the wing, aft of the leading edge, that cause drag by disrupting airflow. For this reason, as well as to reduce energy consumption, the recommended mode of operation is to leave the anti-ice system off and then de-ice the wing immediately following an icing encounter.

The ice detector shown in figure 22 is used as an advisory indicator.

5.3.5.1 Problem Statement

The following statement was sent to the suppliers:

In changing from the current hydraulic actuation systems for control surfaces, to actuation systems powered by electricity, along with the implementation of digital communication in lieu of mechanical cables, and a logical redistribution of computational functions, how would you, as a supplier, configure an actuation system for a control surface utilizing technology that could reasonably be developed, and judged certifiable, by the early 1990's? What is the relative weight, cost, and size when compared to today's systems? What are the benefits and risks of your approach?

Responses received provided a variety of approaches to consider for the IDEA Airplane. The following four paragraphs briefly describe those responses considered suitable:

- A linear type of electromechanical actuator (EMA), similar to that shown in figure 39, was used on the QSRA program for spoiler actuation. A current test program utilizes a similar unit on a Boeing 727 upper rudder.
- The second-generation EMA, used on the 727 upper rudder, consists of a roller screw concentrically surrounded by a variable-speed, variable-torque, rare-earth permanent magnet electric motor.

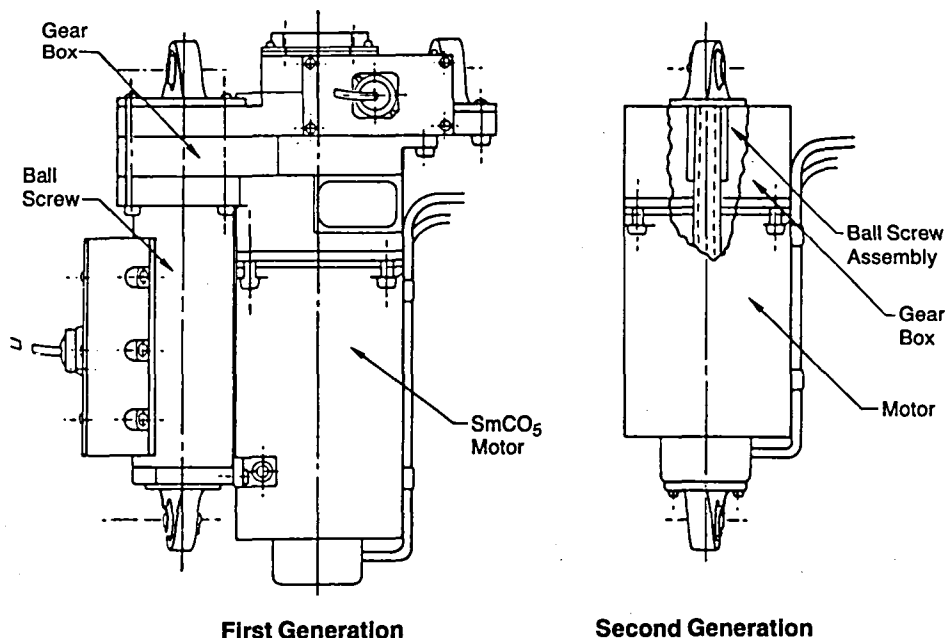

Figure 39. Electromechanical Actuator (EMA)

- The electrohydrostatic actuator (EHA), as shown in figure 40, utilizes a fixed-displacement reversible pump driving an actuator, controlled by a variable-speed, variable-torque, electric motor that has a rare-earth permanent magnet. Such a unit is currently being tested in the 727 lower rudder flight control test rig.

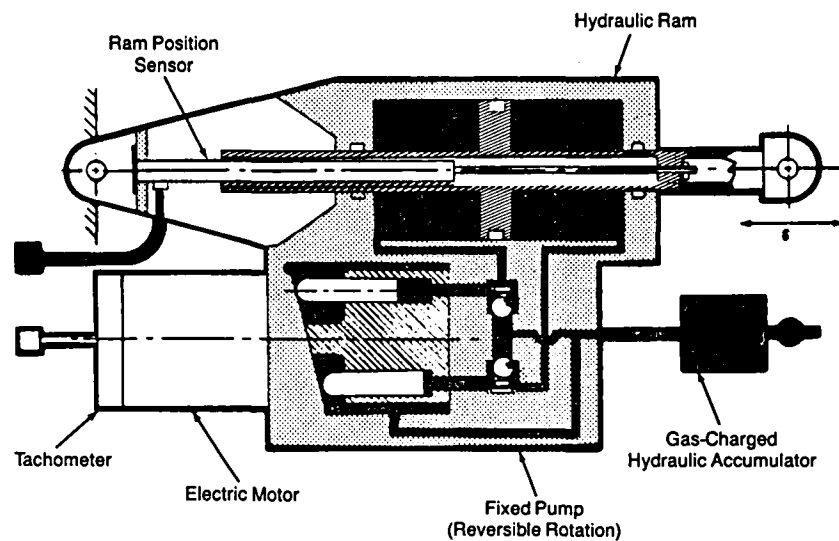

Figure 40. Electrohydrostatic Actuator (EHA)

- The rotary type of EMA (not shown) is similar to the hydraulically powered units used on the B-1 and space shuttle rudder applications, except that the hydraulic motor is replaced with a variable-speed, variable-torque, rare-earth permanent magnet electric motor. (There are variations of this type. Some are shaft-driven, powered hinges as on the B-1 and space shuttle, and others have the motor and gearing as an integrated unit.)

One other inquiry was made regarding electromechanical operation of the current style of wheel friction brakes. The problem statement for the flight control actuators was provided to the potential supplier for reference, with a suggestion that long-term research and development might produce pure electromagnetic brakes (nonwearing, with essentially no maintenance). The resultant response indicated that there were several possibilities for nonfriction brakes. Due to the proprietary nature of the response, the concepts will not be discussed in this report.

5.3.6 ACTUATION RISK AREAS

Other than the installation problems usually encountered during airplane development, the major risks anticipated are all related to the electronics.

5.3.6.1 EMA Controllers

The majority of controllers reviewed appeared to be in the early stages of development. The parts counts were high, (500 to 1,000 discrete electronic parts per motor), and successful operation was achieved only after many failures. Integrated motor controller chips and high-speed, high-power switching transistors specifically for this application must be developed.

It is anticipated that the size of the controller electronic units will diminish with integration of the electronics. (The current controller size for the QSRA spoiler application is approximately 250 in³, the motor being in the 5-hp range.)

5.2.6.2 Generic Faults

With the operation of the actuation system depending completely on both electrical signaling and electrical power, the effect of a generic fault or common mode failure becomes more critical. Considerable effort must be invested in both the hardware and software to work around these problems or minimize their effect.

5.3.6.3 Heat Rejection

The current trend towards composite structure may introduce problems in cooling the controllers. The thermal capacity and conductivity of composite materials is not as good as the familiar aluminum commonly used, and the addition of cooling fans would be undesirable.

If the electronics were made to be more efficient, minimizing the amount of energy wasted as heat, and some means were available to return surplus energy to the power supply system when the actuation system is backdriven (generation mode), the problem might be avoided. Considerable study needs to be performed in both areas to establish the magnitude of the problem and to generate some acceptable solutions.

5.3.6.4 Electromagnetic Interference (EMI)

The large amounts of energy being switched by the motor controllers could present a serious EMI problem. Protection of both the power supplies from the controllers and the controllers from each other (crosstalk) could be an extensive task. The resulting EMI effects on the remainder of the airplane should also be studied.

5.3.6.5 Transmissions

The majority of proposed transmissions included some form of device with rolling metallic contact under load.

The wear life cycle requirements for a typical inboard aileron actuator includes many millions of small amplitude cycles with a fairly high, constant hinge moment. Because of this, problems may occur in keeping gears, bearings, etc., lubricated adequately in local areas, resulting in premature failures. Life testing of a system with actual flight-imposed loads and cycles would be an advisable precursor to the establishment of final design requirements.

The study of newly available materials and composite materials for these applications may also offer some attractive benefits.

5.4 ELECTRICAL SYSTEM

5.4.1 STUDY OBJECTIVES

In the IDEA configuration, all of the functions of the secondary power system are powered by the electrical system. Key issues in developing this configuration are related to replacing pneumatic and hydraulic power sources and systems with electrical equivalents having equal or superior safety, performance, and costs. These issues are:

- 1) Availability of a sufficient number of dissimilar sources to supply dependable, uninterrupted power for flight-critical functions, thus ensuring safe flight and landing after loss of all primary sources as a result of system failures or operational blunders. (Uninterruptible here means that typical prime-mover and power source failures will not result in loss of a channel. There are some single-failure cases, such as loss of an electrical feeder, which will cause loss of the channel).
- 2) Magnitude and character (rates, duration, etc.) of the flight-critical actuation load demand.
- 3) Appropriate generation and distribution techniques to supply the various utility, essential, and flight-critical load demands of an all-electric airplane.

Consideration of these issues early in the study led to the evolution of several fundamental system objectives and concepts:

- 1) Active sources -- Where possible, the same source should be used for emergency and normal power so that proper functioning of the emergency source is continuously demonstrated by its normal operation.
- 2) Isolated sources -- Power abnormalities on one flight-critical channel must not be propagated into any other flight-critical channel through the power system.
- 3) Minimum conversion -- The power system configuration should require a minimum of in-line, power-conditioning conversions to maintain high efficiency and to minimize equipment costs.

5.4.2 SYSTEM SELECTION

5.4.2.1 Options

Some of the generation and distribution techniques considered in developing the selected system configuration are shown in figure 41.

Generation

- Emergency System Sources
 - Ram Air Turbines
 - N₁ Engine Rotor
- Isolated Windings — Separate Generators for Flight-Critical Functions
- Wound Rotor — PMG

Distribution

- Variable Voltage/Variable Frequency
- 270 VDC
- High Frequency
- Combinations
- Centralized vs Distributed Power Conditioning

Figure 41. Options

Early in the study, the concept of multiple isolated stator windings in a common generator was considered as a means for providing isolated sources. Although isolation is not complete, this could be a useful concept for some applications. Since the IDEA configuration required a sufficient number of separate generators for other reasons, isolated winding generators were not selected.

In the area of power distribution/conditioning, the concept of distributed power conditioning was considered briefly. In this case, power as generated is supplied directly to the flight-critical LRUs, where any necessary conditioning required is accomplished in and by each LRU. This implies more complex power supplies in each LRU and perhaps some weight impact, but should improve functional reliability where multiple LRUs are required for failures other than power loss. For example, a power supply component failure in an individual LRU will have less impact than a similar component failure in a centralized power supply which feeds one-third of the total flight-critical airplane loads.

The trade studies required to quantify the relative merits of distributed vs centralized conditional configurations are complex. They involve the disciplines of several airplane systems, as well as equipment suppliers, in iterative, probing definition/evaluation cycles which were not feasible in the relatively short IDEA Airplane study. For example, the centralized power conditioning approach, with power distributed at 270 VDC, was selected to expedite the overall system study; the distributed concept and alternate power types are worthy of more detailed examination in further studies.

5.4.2.2 Selected System

The selected system is shown schematically in figure 42. An essential feature is a flight-critical power subsystem which consists of three channels of 270-VDC distributed buses, each powered from a dual-monitored power conditioner (DMPC) to provide the redundancy required for flight-critical functions. Two of these receive power from 20-kW DC generators driven by the N_1 rotor of each engine. The third DMPC receives power from a 20-kW DC generator motor driven from either of the two utility buses. The same unit can also be deployed as a ram air turbine, with the turbine blades clutched in at deployment. The three DMPC units each also receive power from two of the four utility generators via utility buses M1 through M4. The DMPC units are discussed in more detail below.

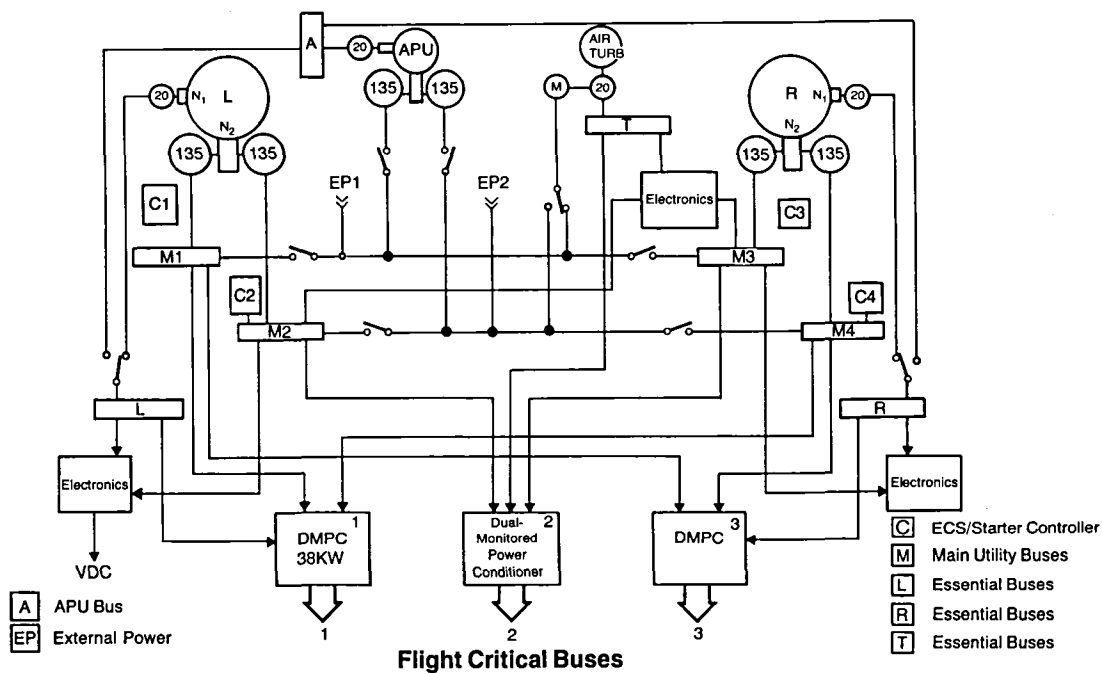

Figure 42. Electrical System Schematic

The utility system consists of two 135-kVA (rated at ground idle), variable-voltage/variable-frequency generators driven by the N_2 rotor on each engine, arranged as two independent two-generator systems. The generators are sized so that a single unit is adequate for starting the engines under most conditions; both are used for very cold conditions. Converter/controller units are provided for powering the generators as motors for engine-starting, and these are also used to drive the variable-speed compressor motors of the environmental control system (ECS).

The utility system also supplies power to electronics power conditioners (EPC) similar to the DMPC units, except they are simpler, single channel units used to power the essential and nonessential electronics equipment.

An auxiliary power unit (APU) is provided which duplicates the engine-driven power sources for ground operations and for dispatch with inoperative generator channels for those airlines (assumed to be the majority) whose operations require one.

5.4.2.3 Dual Monitored Power Conditioner (DMPC)

The DMPC is shown schematically in figure 43.

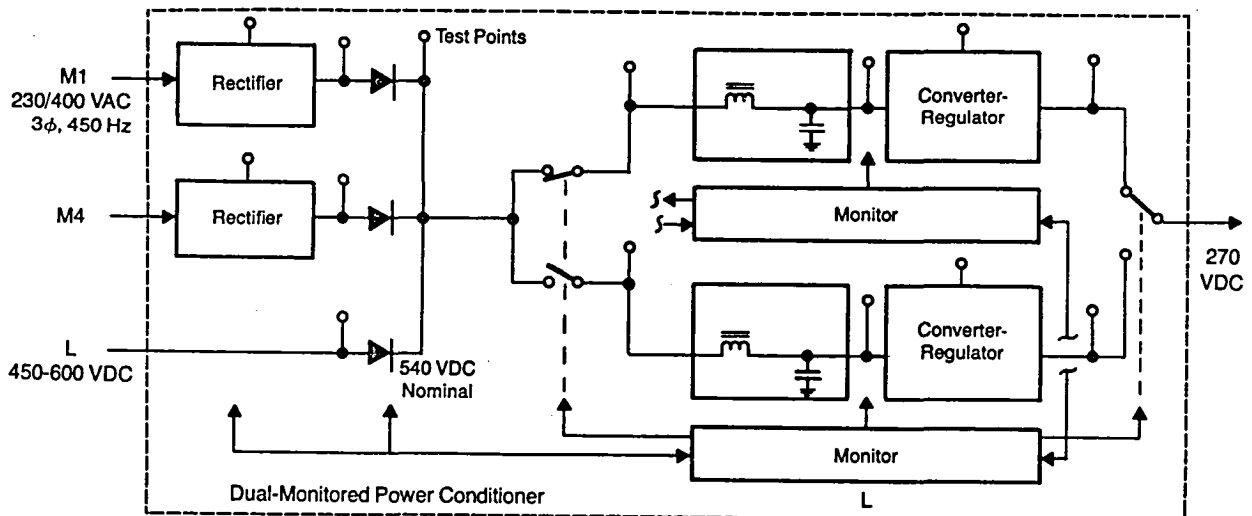

Monitor Functions

- Power Processing Steps and Devices, Input-to-Output
- 270 VDC Bus Status
- Fault Management Logic and Control
- Regeneration Power Management

Figure 43. Dual-Monitored Power Conditioner

The DMPC consists of an input section, where the 20-kW N_1 generator output is combined with the rectified output of two utility generator outputs in a diode-OR arrangement, dual channel converter/regulator sections, a comprehensive real-time monitoring and control section, and a switching section which, commanded by the monitors, selects one of the converter/regulator channels to supply power to the 270-VDC distributed bus.

The monitoring functions provide sensing and control for the complete flight-critical power subsystem, from input sources through LRUs. These functions will be required for any advanced electrical power system, and will benefit from research and development leading to further application of microprocessor and data acquisition technology to the secondary power system.

The flight-critical power subsystem demand is shown in table 20. The maximum demand condition is representative of an engine-out cross-wind landing. The load analysis is based on the power required per surface at the maximum rate and deflection, and assumes that the actuators share the load equally where multiple actuators are used. The maximum DMPC capacity required is 38 kW for a duration of five seconds or less, comparable to the traditional 200% overload rating for wound rotor generators. The average, or continuous, load demand is 10 amps per channel for powering the various electronics elements, i.e., computers and controllers.

Table 20. Flight Critical Load Demand

Maximum Demand, Amps at 270 VDC	
Elevators	90
Ailerons	30
Spoilers	180
Rudders	95
Computer/Controllers	30
Total	<u>425</u> Amps

The DMPC is a critical component in the selected system. Since each unit powers one-third of the flight-critical elements, the reliability requirements are severe. Since each unit must match peak power demand, each has a high ratio of installed capacity vs average power delivered. These characteristics illustrate the impact of simplifying the design requirements of the various using LRUs. Design of a successful DMPC requires significant improvements in power electronic components, circuits, and packaging.

5.4.2.4 Utility System Demand – Main Generator Capacity

Table 21 shows the continuous power demand by flight phase.

Not shown on table 21 are some loads such as landing gear and flaps which, although large, are of short duration and fall within 5-min or 5-s generator overload ratings and do not affect the generator size.

Table 21. Utility System Power Demand

	Takeoff	Cruise	Descend	Single Engine
ECS	215	350	350	340
Instrumentation/Communication/Navigation	8	8	8	8
Equipment/Furnishings	60	65	—	—
Fuel	15	15	15	8
Ice/Rain/Protection	10	15	15	10
Lights	10	10	10	10
Miscellaneous	5	5	5	5
Subtotal	323	468	403	376
Distribution Losses	16	23	20	19
Total	339	491	423	395 KVA
Required Capacity per Engine	170	250	210	395 KVA ⏏ Sizing Condition

- 15 to 30 Min Average, KVA

The generator sizing condition is the engine out (single-engine) case, where all the essential and flight-critical loads must be supplied from the remaining engine (after dispatch with one system inoperative for APU-equipped airplanes). For a single generator per engine, the rating required is 395 kVA, as shown.

A single 395-kVA unit was considered to be difficult to remove and install on the engine and would result in a larger, higher drag nacelle configuration, although it would be cheaper and lighter than two generators. Two generators per engine were selected because they provide additional isolated sources, better engine matching for starting requirements, and additional operational flexibility under failure conditions.

Generator capacity as a function of N_2 speed, or throttle setting, is shown in figure 44. The generator is designed to provide nominal 230/400 V 3 ϕ , approximately 450 Hz at cruise conditions. At ground idle speed it is designed to provide 290 A per phase for engine starting. At this speed, 155/270 V 3 ϕ is developed, resulting in a generator capacity of 135 kVA.

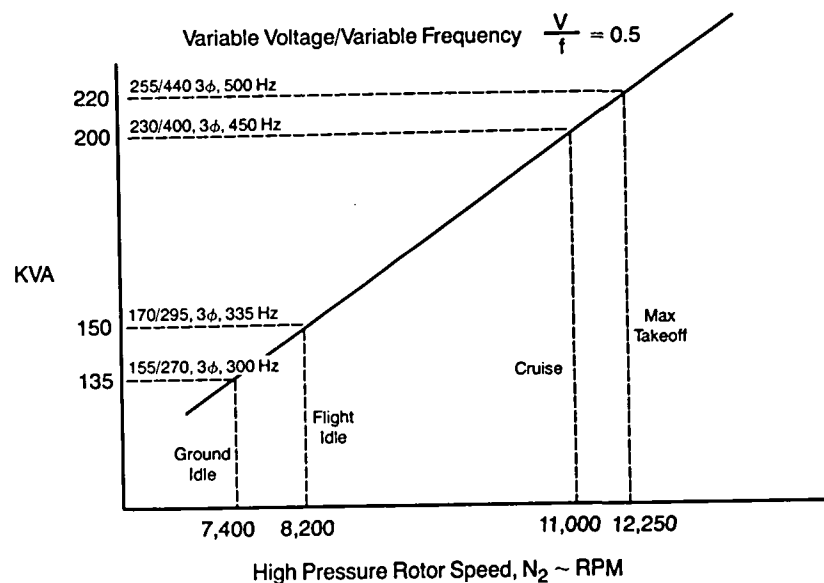

Figure 44. Generator Capacity

At cruise conditions, including single engine thrust settings, 200 kVA is developed per generator so that 400 kVA per engine is available to meet the 395-kVA demand shown in table 21. The ECS demand reduces substantially at lower altitudes (see sec. 5.7), so the load demand decreases at single engine altitudes and drops significantly as altitude decreases below 25,000 ft and thus remains within the single-engine capacity during descent.

The selection of the variable-voltage/variable-frequency approach allows use of conventional-design motors and other common load equipment without other power conditioning or conversion required. The major motor loads – flaps, landing gear, fuel pumps – and numerous smaller loads such as cargo doors and flush motors can use off-the-shelf designs, modified for double-voltage operation.

5.4.2.5 Electrical Equipment Locations

The major electrical equipment installation locations are shown in figure 45.

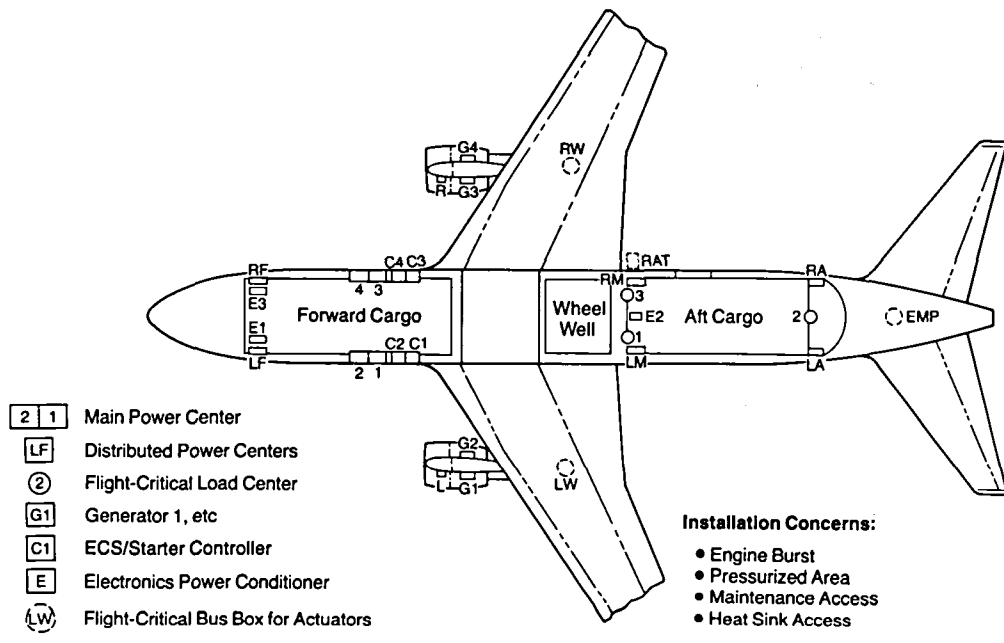

Figure 45. Electrical Equipment Locations

The flight-critical components are, for the most part, located in the wings, empennage, or midbody area, so the DMPC units are located to minimize power feeder lengths. Other main and distributed power load centers are located in the fore, mid, and aft areas, left and right, to provide separation of functions and to minimize feeder weights. Distribution-bus junction boxes are located in each wing and in the empennage.

5.4.3 ALTERNATE POWER DISTRIBUTION – FLIGHT CONTROL SUBSYSTEM

The flight-critical power subsystem is an autonomous, self-contained power conditioning/distribution configuration and lends itself to a simple, if superficial, evaluation of an alternative high-frequency power conversion/distribution system.

The converter/regulator sections of the DMPC are switched-mode power supplies typically operating at frequencies in the range of 20 kHz. If the rectifier and filter components are deleted, the output could be 20 kHz at 440 Vrms. The LRU power supplies are revised to operate from 20 kHz input power, rather than 270 VDC, to allow deletion of components for weight reduction.

The 270-VDC power feeders are then replaced by some transmission line configuration suitable for power levels typical of the flight control actuators.

Review of the flight control power demand (sec. 5.4.2) suggests that feeder power dissipation losses by themselves are not a primary consideration, since the load demand is of such short duration that cable heating effects are minimal. Instead, feeder design for this particular application would emphasize minimum feeder voltage drop to better match DMPC and LRU design requirements and system performance.

Minimum voltage drop at 20 kHz frequencies means a low series inductance. This implies high shunt capacitance, based on the relation $Z_0 = \frac{L}{C}^{1/2}$ for a transmission line with no loss, or more generally, $LC = \frac{1}{c^2}$.

Conventional high frequency transmission lines, such as coaxial cables, were examined to provide some understanding of the orders of magnitude involved. Typical coaxial cables have capacitances on the order of 100×10^{-12} Farad/meter, with corresponding inductances on the order of 200×10^{-9} Henry/meter. At 20 kHz the resulting voltage drop due to the inductive reactance is several times that of the equivalent 270-VDC feeder. Stated differently, for an equivalent percentage voltage drop in the feeders, the 20-kHz conventional coax feeder weight is several times the 270-VDC feeder set, including power and return wires, and offsets the reduced DMPC and LRU weights.

Based on this scoping evaluation, other feeder configurations were examined briefly, particularly those offering higher capacitance.

The obvious high capacitance feeder construction is some form of multilayer configuration with power and return conductors interleaved and insulated with a relatively high dielectric-constant material. In either circular or rectangular arrangements, termination/connector design is a formidable problem and was not investigated.

In summary, although the high-frequency distribution system would simplify the DMPC and LRU power supply design and have better power control switching characteristics for fault-clearing, in this application it would weigh significantly more than the reference 270-VDC system. This is due largely to the current lack of appropriate high frequency feeder designs, so further research and development could change this conclusion.

5.4.4 CONFIGURATION SUMMARY

The electrical (secondary power) system for the IDEA configuration is representative of a first-generation all-electric airplane in that the emphasis on advanced technology is in the areas of fly-by-wire/power-by-wire while retaining a low-cost, low-risk utility system configuration.

It incorporates the philosophy that the normal power sources for the flight-critical functions should also be the power sources for the all-engines-out situation; the "emergency" power sources are always used. The ultimate engines-out energy source is ram air and in this configuration is tapped via N_1 rotor-driven generators and a fairly conventional ram air turbine. Some form of continuous ram air turbine (tip vortex generators, etc.) may be a better choice given appropriate research and development.

The centralized power conditioning philosophy incorporated has been discussed in section 5.4.2.1, and a more thorough evaluation of distributed conditioning configurations is recommended. In either case, continuing research in power conversion/conditioning technology is a requisite for all-electric airplanes.

Distribution of flight-critical power at 270 VDC in this configuration was selected to simplify airplane-system-supplier overall configuration studies, and detailed comparison trade studies with other distribution techniques was not attempted. There is much work to do in conversion and switching technology before high-voltage DC distribution systems could replace the three-phase AC systems on commercial airplanes.

In section 5.4, the discussion of the selected electrical system configuration highlighted particular fly-by-wire/power-by-wire technology areas for further research and development. For future work, the selected configuration will act as a basis for more detailed configuration definition and evaluation of all-electric airplane concepts.

5.5 DATA DISTRIBUTION AND AVIONICS SYSTEM

5.5.1 STUDY APPROACH

The data distribution system for the IDEA configuration must meet the performance and reliability requirements of the flight critical systems while forming an efficient and cost-effective data path for the less critical functions. The system provides data paths between major subsystems (flight control, electrical, propulsion, etc.) and between some components of the same subsystem.

There are two direct payoffs for the airplane in this kind of system. Both are due to a reduction in airplane wiring. Less wiring yields a direct weight savings and also results in production, installation, and checkout cost avoidance for the miles of eliminated wiring. A less obvious benefit, compared to current airplanes, is that a data distribution system is extremely flexible for future capability upgrades or for airline-specific avionics installation. Another indirect benefit is that the system provides a global data base, allowing new architectures in which system elements are integrated via data. In these systems functional partitioning constraints due to physical interconnection complexity largely disappear.

A concern with this kind of system is that, since the data transfer takes place in a more shared manner, central failure modes in the distribution system must be very unlikely. The distribution system design must prevent propagation of failures through hardware and software partitioning.

Due to the all-encompassing nature of the integrated digital electric concepts and the data distribution system, a broad top-down approach would be ideal. However, this type of effort would have required more resources and calendar time than was available. Since one objective of the IDEA study was to define a flight-critical flight control system, a more abbreviated approach, emphasizing the requirements of that system, was taken for the definition of the data distribution system.

The study had two major activities. The first was to identify the data transfer requirements in terms of signals, sources and destinations. The second was to develop a distribution system structure or architecture.

5.5.2 DATA TRANSFER REQUIREMENTS

The IDEA Airplane requirements were defined by first surveying the Baseline airplane and then assessing the impact of the IDEA concept on the data flow.

The requirements were estimated by first using the Baseline airplane signal flow where available. Where not available, a pre-Baseline version was used. The flight management system (FMS) signal flow was taken directly from the applicable subsystem interface control documents (ICDs). For the digital signaling of the IDEA configuration, update rates were estimated for analog signals and additional packed discrete words were created for the existing analog discrettes. Detailed FMS function repartitioning efforts were held to a minimum due to the scope of the IDEA study. The resulting IDEA-based traffic reflects Baseline FMS signals with only minor modifications.

Flight control system traffic was estimated based on previous Boeing FBW system studies and general airplane signaling requirements. Traffic for the IDEA configuration was estimated directly. The propulsion control and indication traffic was based on the baseline configuration which had been modified to incorporate different engines. The only IDEA configuration change was to perform all signaling via the data distribution system and to electrically power the thrust reverser actuator. The signal flow was estimated using available system schematics, wiring diagrams and ICDs for a current airplane installation.

The utility system scope covered the functional areas of environmental control, electrical power, fire protection, auxiliary power, landing gear, fuel, high lift, and ice and rain protection. For these systems, signals were cataloged by either source location or destination location in the airplane. This method covers those elements providing control, display, sensor or actuator functions. The assumption was that these elements define the required data path and any logic or processing functions can be located anywhere on the interconnecting bus. The survey did not include the hydraulic and pneumatic power systems since they are not part of the IDEA configuration.

5.5.3 DATA DISTRIBUTION QUALITATIVE SCREENING

In order to consider system alternatives in the short span of this study, a qualitative comparison of certain data distribution system characteristics was performed. An overview of the characteristics is shown in figure 46. The selection of the candidate systems was based on the results of this comparison. The key advantages and disadvantages are shown in table 22.

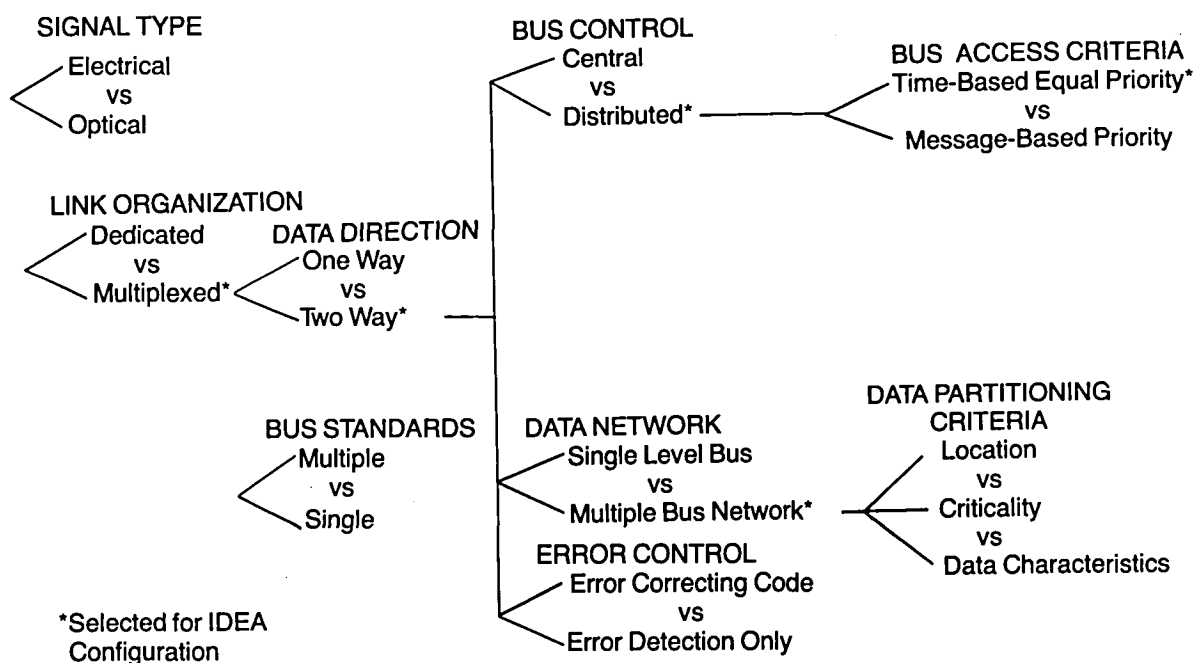

Figure 46. Data Distribution Options

Table 22. Data Distribution Qualitative Comparison

<u>Signal Type</u>	<u>Advantages</u>	<u>Disadvantages</u>
Electrical	Long experience Connection flexibility	Lower bandwidth EMI and EMP susceptibility
vs		
Optical	High bandwidth EMI and EMP immunity Weight Electrical isolation	High link attenuation Low electrical/optical/electrical conversion efficiency High connector loss Limits on practical topology
 <u>Link Organization</u>		
Dedicated	Link loss affects only one signal	Large number of links
vs		
Multiplexed	Large reduction in links and interfaces	Single link loss affects many signals More complex sending and receiving functions
 <u>Data Direction</u>		
One Way	Simpler communication protocol	More links More receivers
vs		
Two Way	Fewer links Fewer receivers	Needs more complex bus access protocol "Babbling" transmitter central failure mode

Table 22. Data Distribution Qualitative Comparison (Continued)

<u>Bus Control</u>	<u>Advantages</u>	<u>Disadvantages</u>
Central	Control complexity in one unit Simpler bus access protocol	Command/response overhead traffic Central failure susceptibility
vs		
Distributed	No single control failure	More complex bus access protocol
<u>Bus Access Criterion</u>		
Time Based Equal Priority	Natural support of continuous processes (uniform update)	Inefficient handling of combined bursty and continuous traffic
vs		
Message Based Priority	Most flexible link utilization	Complex traffic resolution protocol Bus access overhead traffic
<u>Data Network</u>		
Single Level (Redundant) Bus	Fewest links "Data highway" simplifies physical interconnection	Needs high bandwidth
vs		
Multiple Link Network	Lower bandwidth required in low level links	Needs "gateway" or "bridge" between links Needs cross link protocol More links
<u>Error Control</u>		
Error Correcting Code	High message transfer integrity Good for higher bit error rate channels	More overhead traffic More complex protocol
vs		
Error Detection Only	Less overhead traffic simpler protocol	User function must tolerate message loss Suitable for low bit error rate channels

Table 22. Data Distribution Qualitative Comparison (Concluded)

Data Flow Partitioning

Criterion

Advantages

Disadvantages

Location

Minimum total bus length

Bus redundancy based on most critical data – more busses

vs

Criticality

Bus redundancy can match criticality – fewer busses

Duplicate bus routing – longer busses

vs

Data Characteristics

Protocol can be optimized for type of data on link

Bus redundancy must be based on most critical data
Duplicate bus routing

Bus Standards

Multiple Standards

Each link optimized for specific transfer

Inflexible

High total cost of multiple standard development

No growth capability

vs

Single Standard

Single development effort interchangeability eases maintenance support

May be difficult to satisfy widely varying requirements

Based on the comparison, two candidate systems were proposed. In order to achieve the larger payoff, both systems were based on two-way, decentralized control, linear data buses using a broadcast method of data transfer. These characteristics result in a flexible data transfer system which is relatively insensitive to the addition or deletion of transmitters.

The first system was based on a global data bus, a single set (triple redundant) of buses interconnecting all communicating elements. In order to handle the mix of critical, noncritical, uniformly updated and irregularly updated data, an advanced protocol that controls transmitter activity cooperatively on a message-by-message basis is necessary.

The second system was made up of three different bus types. Data partitioning was based on a combination of criticality and timing characteristics. The transmitter scheduling protocol was based on time, with each station having equal priority. Bus protocol and other characteristics for all three bus types are essentially those of the DATAC data bus developed at Boeing and installed in the NASA Transportation System Research Vehicle (TSRV), a 737 research airplane. The second system relied on units being connected to more than one bus type in order to have access to data on different links rather than retransmitting data through gateways or bridges.

From the data distribution system candidates, the second system was selected as the final choice. The resulting system is composed of seven data buses. There are three redundant control buses operating in a DATAC A mode (uniform update rate) carrying pilot control, propulsion control, surface commands, steering and wheel brake information. Two redundant sensor buses which also operate in a DATAC A uniform-update-rate mode carry body motion, air data, engine indication, radio navigation and other information. Finally, two redundant management buses using the DATAC B mode (variable-message-length protocol) carry data link, radio tuning, system mode change commands, system status change and other data. The resulting system will be described in more detail later.

5.5.4 IDEA IMPACTS

The direct payoffs in the data distribution area come from elimination of wiring, as mentioned previously. There are 4,200 lb of signal and power wiring on the IDEA baseline.

One IDEA concept to reduce signal wiring is shown in figure 47.

To reduce the signal wire length, the signal conditioning and conversion circuitry is moved closer to the signal source. Signals are then converted and put on the airplane data distribution system at remote locations, rather than being sent over long dedicated wire runs.

Another IDEA concept, remote control of electrical loads, is shown in figure 48.

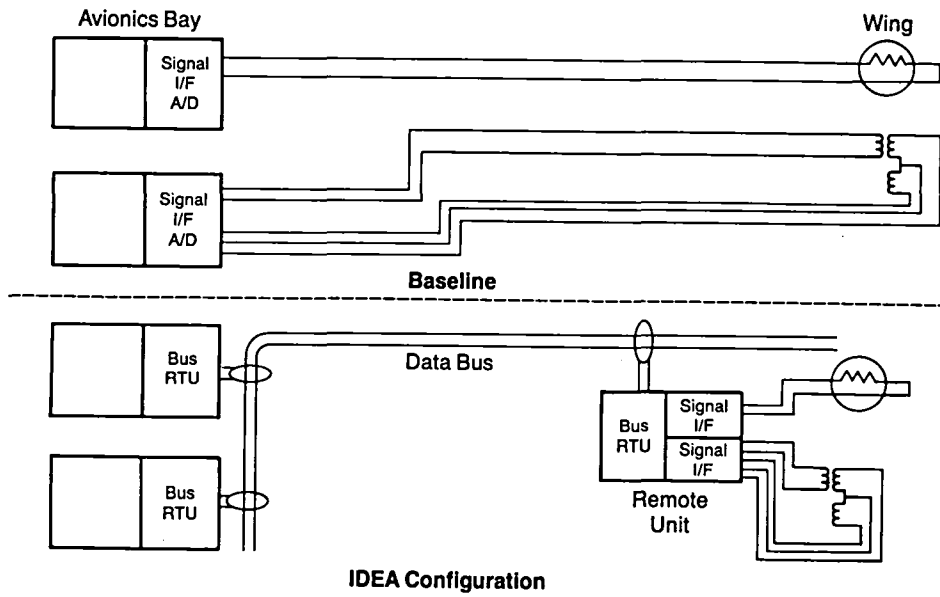

Figure 47. New Signal Interface Circuit Locations

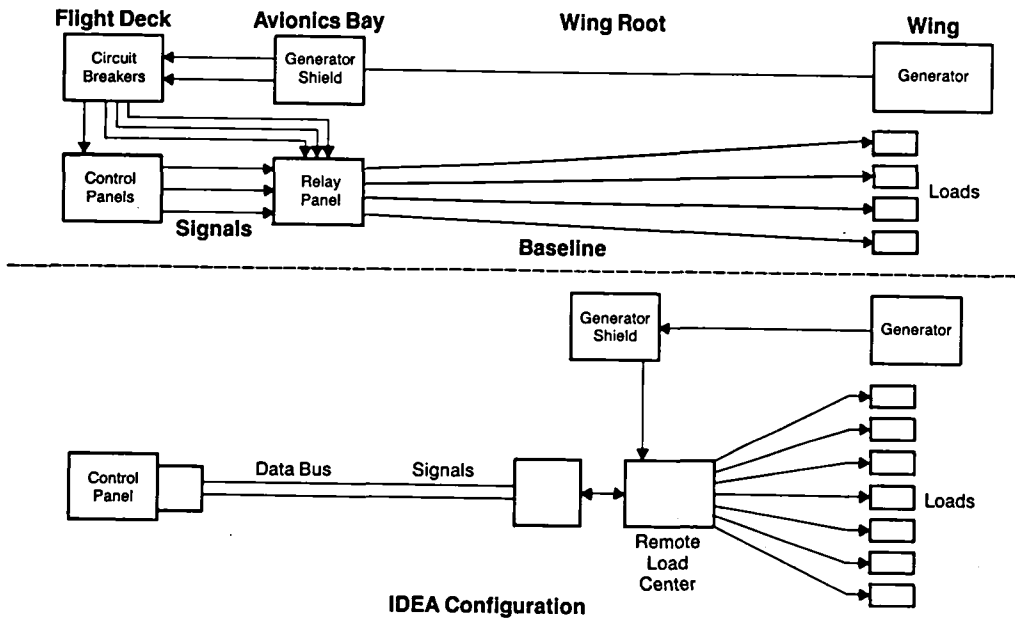

Figure 48. Power Switching and Circuit Protection Location

In the IDEA Airplane, since electrical devices replace all pneumatics and hydraulics, the electrical load requirements are more numerous than those of the Baseline. The use of remote load centers, in combination with remote control circuit breakers, would shorten the length required for the necessary number of power wires. However, this would also result in a large increase in the amount of wire required for control signaling, unless this function were handled by a data bus.

In addition to the signaling changes described above, three additional ground rules, based on integrated digital considerations, affected the system. First, it was assumed that all logic functions performed by relays and cardfile-based discrete logic devices would be reimplemented in computer-based hardware. Second, all power controller circuits for the new electric actuators were assumed to be located near the actuators. This involves functions such as gear extend-retract, normal high-lift drive, nosewheel steering, etc. Finally, for maximum wire weight savings it was assumed that control-loop closure circuits would be located near the actuator rather than in the avionics bay. This involves relocating functions like brake control, ECS modulating valve control and pressurization outflow valve control. To achieve the full benefits then, electronics will be located in unconditioned, less accessible areas. Research essential for development of these capabilities is outlined in section 8.0.

As a result of the additional groundrules, many functions were relocated outside the avionics bay. Using a previous Boeing internal study as a model, many of these functions were associated with 15 remote units distributed throughout the airplane. These remote units have four main functions: 1) they provide a signal conditioning and conversion interface for sensors in the vicinity; 2) they provide a signaling interface for the remote control circuit breakers which provide local load control and circuit protection for the small electrical loads on the IDEA Airplane; 3) they perform indicator and lamp drive for dedicated displays; and 4) they act as regional computers for some of the system logic functions. An overview of the remote units is shown in figure 49. The new unit functions are shown in more detail in table 23. Table 23 also describes the assumed functions of the airconditioning control units and the new groundrules.

Remote Units

Function	Pilot Flt Control	Flt Deck Area	Forward Area	Mid Area	Gear Area	Wing Area	Aft Area
Remote Signal Interface	X	X	X	X	X	X	X
Remote Load Control/ Circuit Protection			X	X			X
Regional Computing (Logic)			X ¹	X ²	X ⁵	X ⁴	X ³
Indicator/Lamp Drive Interface		X				X	

- 1 Logic for: Equipment cooling, Nosewheel Steering, Landing Gear
- 2 Logic for: Slat Control, Fuel System, Fire Protection
- 3 Logic for: Automatic Pressurization, Fire Protection
- 4 Logic for: Anti-Ice
- 5 Logic for: Wheel Brakes, Landing Gear, High Lift Control

Figure 49. Remote Unit Functions

Table 23. New Unit Summary

<u>Qty</u>	<u>Name</u>	<u>Summary</u>
2	Flight Deck Area Remote Units	Signal conditioning (sensor excitation) and digital conversion for sensors in flight deck area. Interface (A/D) to bus for system controls and drive dedicated system displays (lamp drivers, fuel quantity, etc.). Interface for air data probes.

Table 23. New Unit Summary (Continued)

<u>Qty</u>	<u>Name</u>	<u>Summary</u>
2	Forward Area Remote Units	RCCBs for electric loads in forward area of airplane. Activation/ deactivation commanded and circuit status reported on bus. Signal interface for flight-essential power conditioners, equipment cooling controller, nose wheel steering controller, nose gear controller and window heat controller. Regional computing by incorporating equipment cooling logic, nose gear logic. Signal conditioning and conversion for local sensors.
2	Mid Area Remote Units	Signal conditioning and conversion for local sensors. RCCBs for miscellaneous loads in mid area of airplane and in wings. Signal interface for dual-monitored power conditioners, flight-essential power conditioners, and L.E. slat power controller. Regional computing by incorporating L.E. slat logic, fuel system logic, and fire protection system logic.
2	Air Conditioning Controller Units	Replace pack flow processors, temperature controllers, backup and standby controllers, zone temperature controllers, and associated analog cards and relays. Control air conditioning modulating valves directly. Signal interface for A/C packs and ECS compressor/starter power converter. Air conditioning system logic.

Table 23. New Unit Summary (Continued)

<u>Qty</u>	<u>Name</u>	<u>Summary</u>
4	Electrical System Control Units	Replace generator control units, bus power control units and DC tie control unit. Incorporate power sensors and breakers, and perform electrical system logic.
2	Gear Area Remote Units	Replace antiskid/autobrake control units, air ground relays, and brake control relays. Signal interface for brake controllers, T.E. flap controller, and main gear controllers. Regional computing for landing gear logic, flap logic, wheel brake logic. Signal conditioning and conversion for local sensors.
2	Wing Area Remote Units	Signal conditioning and conversion for local sensors. Drive indications and displays on refueling panel (left). Regional computing for wing and engine anti-ice. Signal interface for anti-ice power controllers. Incorporate engine vibration monitor.
2	Aft Area Remote Units	Automatic pressurization control unit. Signal interface for dual monitored power conditioner. Signal conditioning and conversion for local sensors. Service aft RCCBs for miscellaneous electrical loads in aft area of airplane. Regional computing for APU fire protection in addition to pressurization logic.

5.5.5 SELECTED SYSTEM

The final system-organization groundrules, used to define the data distribution, involve the partitioning of data flow between the multiple bus sets. More specifically, the selected data partitioning criteria separated the more critical control data from the sensor data and separated the essentially periodic data from that which is transmitted in occasional bursts. The groundrules also set the criteria for data transfer redundancy. These final groundrules proved easy to follow in most cases, but the selected system has several compromises resulting primarily from considerations based on location or related function. As an example, the management bus is oriented toward burst traffic, but a small amount of regular update information is assigned to it.

An overview of the selected system is shown in figure 50. The system interconnects 105 units throughout the airplane. A list of the units showing the assumed redundancy level and number of bus terminals per unit is presented in table 24.

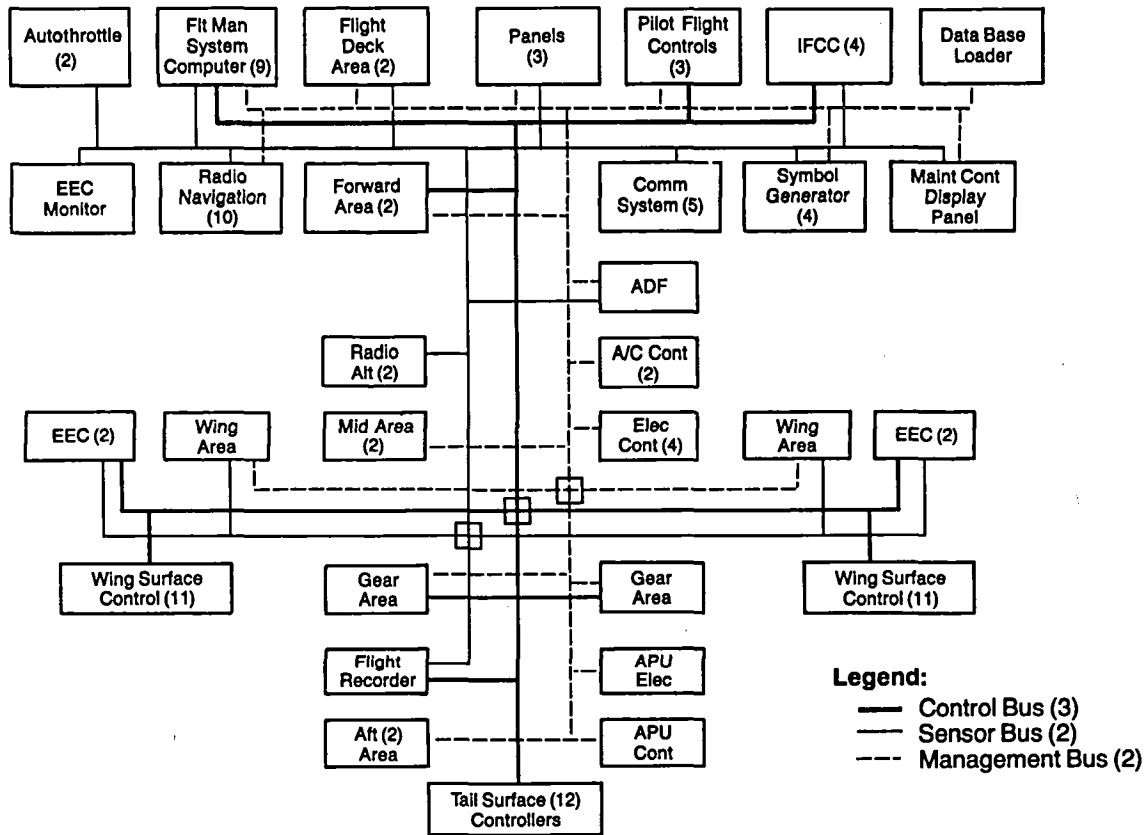

Figure 50. Data Distribution Overview

Table 24. Bus Interconnection Summary

Unit	No. Interconnects/ Unit	Unit	No. Interconnects/ Unit
Pilot Flight Control Remote Unit (PFC)	3	C-1	VHF Transceiver (VHF)
Integrated Flight Control M-2 Computer (IFCC)	4	C-3,S-2	ARINC Comm and Report System (ACARS)
Autoflight Computer (AFC)	3	C-3,S-2	MODE-S Transponder
Aileron SAC	8	C-1	Radio Altimeter
Spoiler SAC	14	C-1	Automatic Direction Finder (ADF)
Elevator SAC	6	C-1	
Rudder SAC	4	C-1	Flight Deck Remote Unit
Stabilizer SAC	2	C-1	Forward Area Remote Unit
Mode Control PNL (MCP)	1	S-2	Electric Control
Control Display Unit (CDU)	2	M-1	Air Conditioning Control
Symbol Generator (SYM GEN)	4	S-2,M-2	Mid Area Remote Unit
Crew Alert + Warn Computer (CAWC)	2	C-3,S-2,M-2	Wing Area Remote Unit
Flight Management Computer (FMC)	2	S-2,M-2	Gear Area Remote Unit
Inertial Reference/Air Data (IRAD)	2	C-3,S-2,M-2	Aft Area Remote Unit
Main Control Display Panel (MCDP)	1	S-2,M-2	APU Control Unit
Elec Engine Cont Monitor	1	S-2	APU Electrical Control
Autothrottle	2	S-1	Data Base Loader
Elec Engine Control (EEC)	4	C-2,S-2	
Flight Recorder	1	C-3,S-2	
VHF Omnidirectional Range (VOR)	2	S-1,M-2	
Distance Measuring Equip (DME)	2	S-1,M-2	
Instrument Land System (ILS)	2	S-1,M-2	
Microwave Land System (MLS)	2	S-1,M-2	
Weather Radar	2	S-2,M-2	

INTERCONNECT LEGEND

C = Control Buses
S = Sensor Buses
M = Management Buses

Two simplifying groundrules, covering the interconnection of redundant functions, are shown in figure 51. The top diagram illustrates the use of an intermediate element to provide a cross-channel path, if called for by the redundancy management strategy. In this approach each unit labeled C can use outputs from both units labeled A and each unit labeled B can use outputs from both C units. The lower diagram shows how information from remote units was allocated for the redundant buses. The bus traffic that results, therefore, reflects a relatively straightforward approach in the area of data transfer redundancy.

More elegant approaches involving data bridges or gateways between buses, should be investigated in future studies using single level bus architectures. Additional data delay aspects of these approaches must be taken into account.

- Separate Control and Sensor Information
- Separate Uniform and Bursty Traffic
- Redundant System Connection Concept

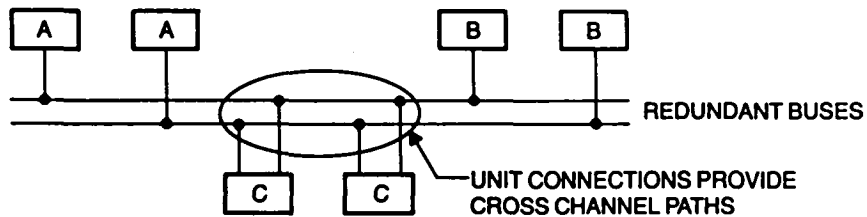

- Remote Unit Bus Traffic

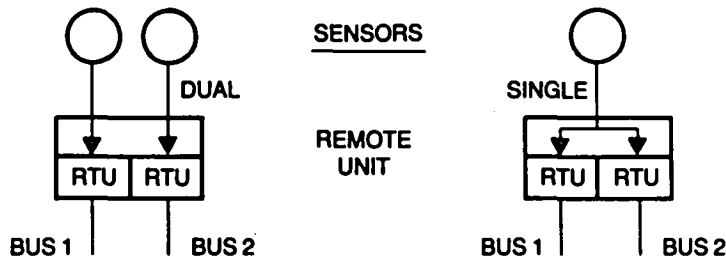

Figure 51. System Organization Groundrules

Details of the selected system are shown, organized by area of the airplane, in figures 52 through 55.

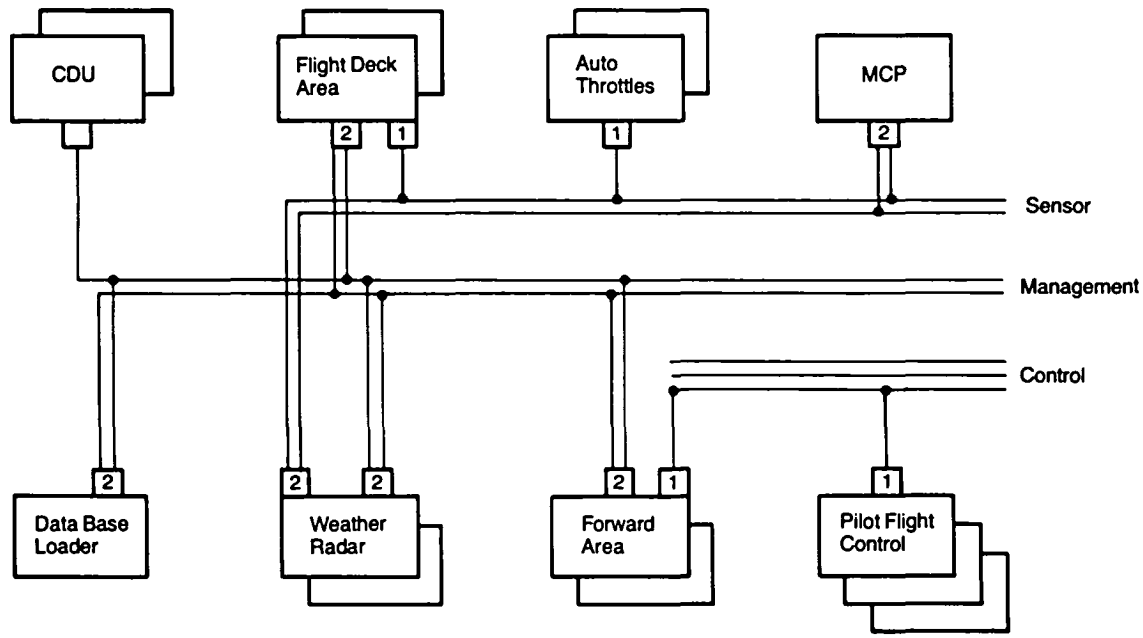

Figure 52. Flight Deck and Forward Area Detail

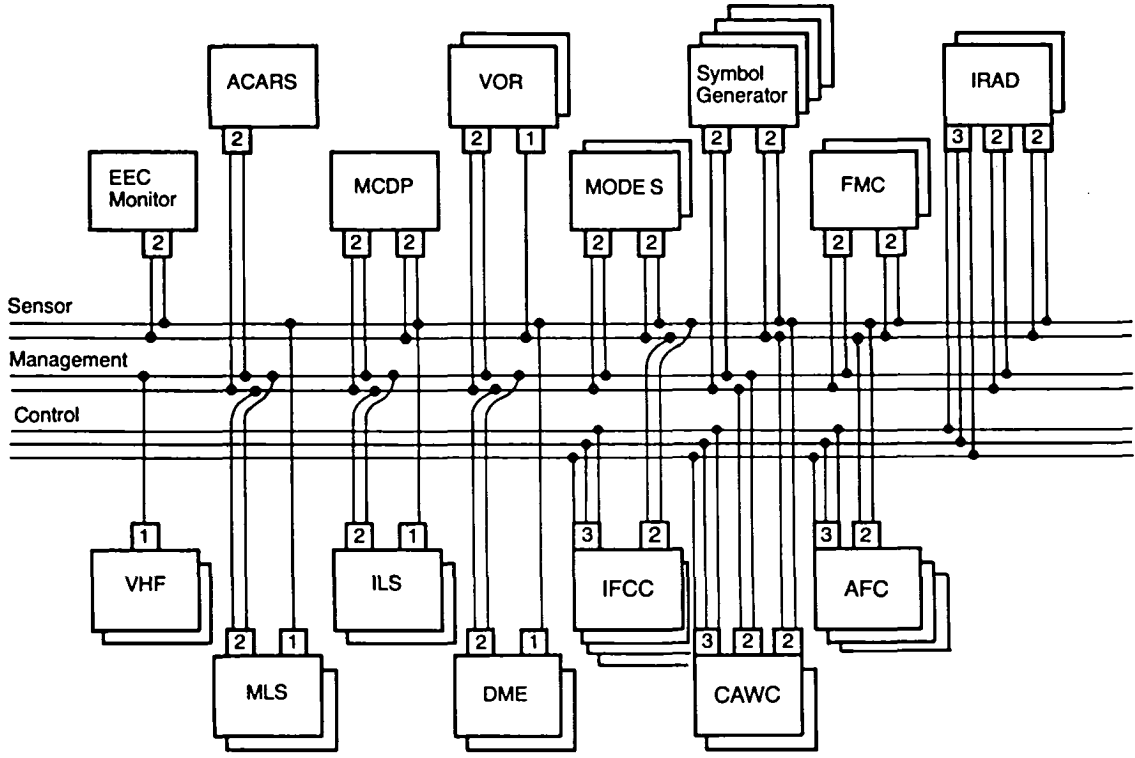

Figure 53. Avionics Bay Detail

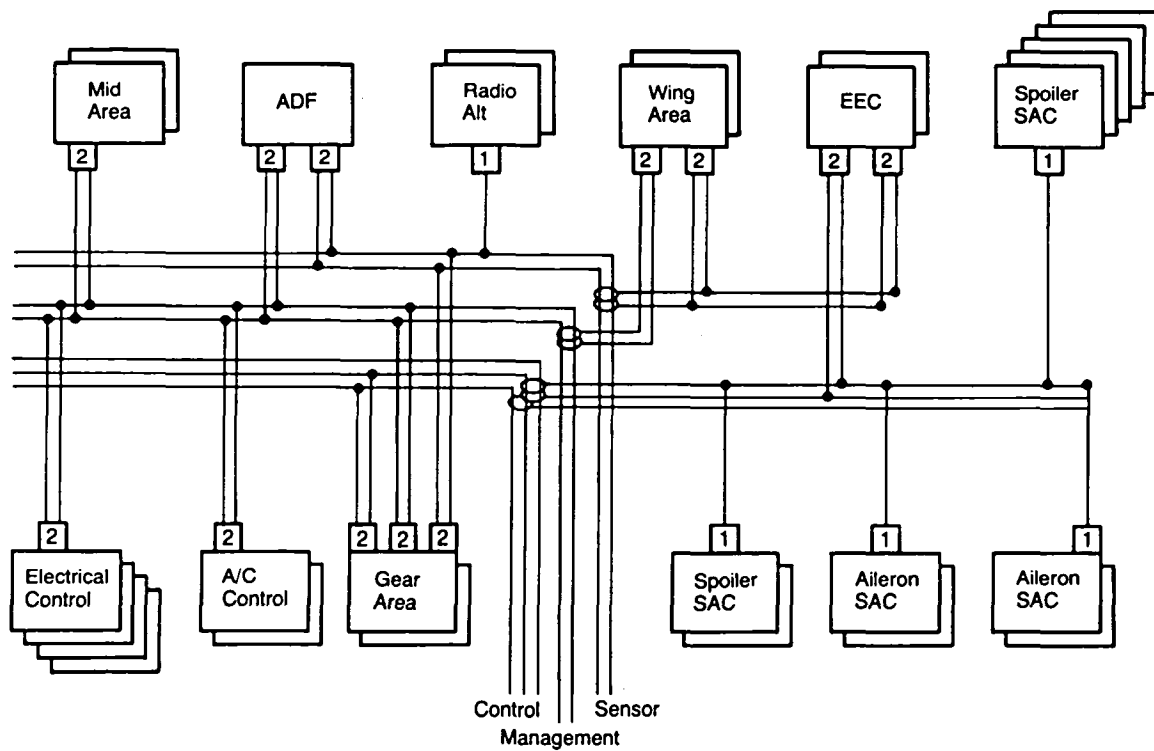

Figure 54. Midbody and Wing Area Detail

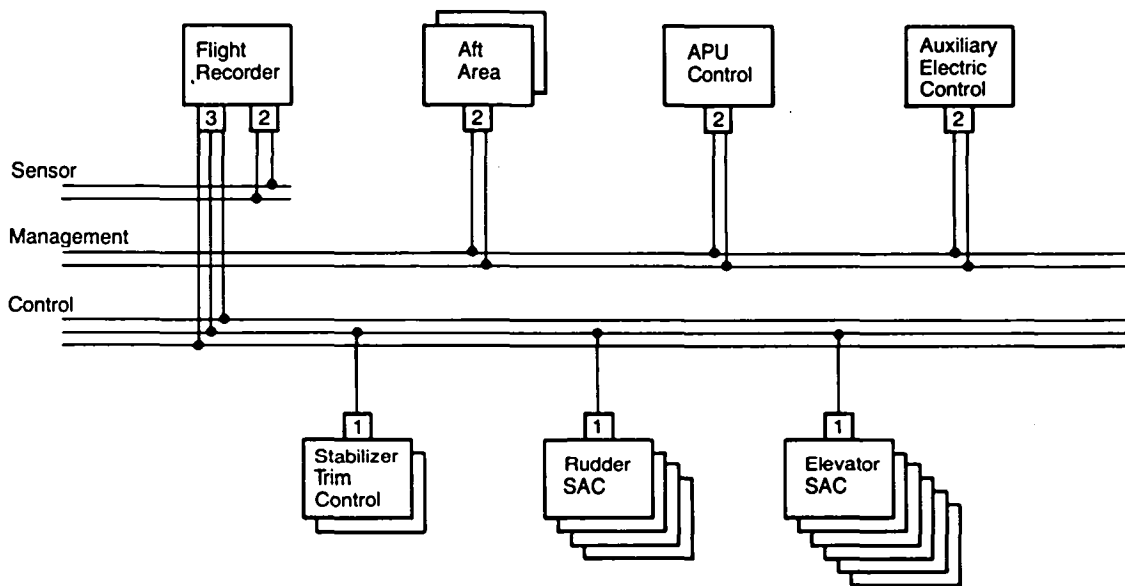

Figure 55. Aft-Body Area Detail

The selected system had nearly 270 bus terminal units installed. The maximum number of transmitters connected to each bus was about 30. There were many receive-only connections in the system. Based on the detailed traffic estimates, the bus loading is: 7,000 words/s for the control bus; 15,000 words/s for the sensor bus; and 7,000 words/s for the management bus. The management bus value is the sum of the peak rates.

5.5.6 STUDY COMMENTS

The data distribution system satisfies the data transfer needs of the interconnected elements. In the advanced systems concept, the data distribution system has to satisfy a wide variety of functions. Additionally, the IDEA study called for the integration of functions which are currently performed in dedicated equipment. This points out the increasing need for a total aircraft systems approach in future aircraft.

The airplane systems architecture defines the following areas: 1) the allocation of functions to system elements; 2) the interconnection of elements; and 3) the provisions for operation under fault conditions (redundancy management). These factors are highly interrelated, with decisions in one area affecting the other areas. Since the data distribution system provides the signal interconnection for the airplane systems, design decisions in areas 1 and 3 directly affect its requirements. Bus requirements can vary widely depending on how the functions are allocated to elements and which redundancy management method is used. In order to develop an effective system, a phased development program emphasizing design iterations and evaluation should be used.

As mentioned in section 5.5.1, the IDEA study scope did not allow a top down definition effort. In a previous NASA study (ref. 8) Boeing defined an iterative method for use in early systems architecture development. The method involves functional decomposition based on required operational capabilities, criticality assessment and an iterative evaluation/refinement process based on hardware and software models of system concepts. The goal of this kind of methodology is the reduction of program risk by development of system level requirements based on early feasibility considerations. The evaluation process emphasized performance in both normal and fault conditions. As described in section 5.5.3, the system layout was envisioned as having a linear bus rather than a ring or star configuration. The linear configuration, for example, simplifies the task of interconnecting communicating elements. It is a good choice for a broadcast mode of operation between cooperating yet autonomous elements and simplifies the future addition of units.

As described in section 5.5.3, the system layout was envisioned as having a linear bus rather than a ring or star configuration. The linear configuration, for example, simplifies the task of interconnecting communicating elements. It is a good choice for a broadcast mode of operation between cooperating yet autonomous elements and simplifies the future addition of units.

Comparing IDEA structures to those of the Baseline, there is only a slight increase in the amount of composite materials used. This may not be the case in other future aircraft. The use of composite structure will increase the exposure of wiring to electrical interference from sources such as static discharge, nearby lightning, direct strike lightning, and aircraft-generated electromagnetic radiation (e.g., HF transmissions).

If electrical signaling and control is used, additional measures such as increased shielding of cables, improved filtering, and improved signaling formats will be required to ensure correct operation of systems under all conditions of electromagnetic interference (EMI).

The design, testing and maintenance of the features used to ensure the integrity of the electrical signals in the EMI environment are difficult due to the poorly defined threat levels, the difficulty of reproducing the full range of threat parameters in a test environment, and the difficulty of evaluating the continued effectiveness of the features during the life of the airframe.

Fiberoptic technology offers an alternative means of signaling by employing the use of modulated light. Since the light signals are transferred through glass fibers which are electrical insulators, they are not affected by EMI. This inherent immunity of fiber optics to EMI provides the following benefits:

- Removes the shielding requirements, thereby reducing assembly costs and weight. NOTE: Shielding can take the form of braided cables, wiring ducts, metal surfaces added to composite structure, and/or conductive material added to the composite layup.
- Removes the EMI verification tests from the certification program.
- Removes the maintenance burden associated with evaluating the continued effectiveness of the shielding.

The failure modes associated with shielded electrical wire include failure of the shield. This does not affect normal operation of the system, but it can cause the system to be susceptible to EMI. This potential failure mode can be detected only by regularly scheduled maintenance of the wiring and shields. In the case of fiber optics, none of the failure modes cause the system to become susceptible to EMI. However, the fiber optic failure modes do affect normal operation of the system. This does not pose a problem since they can be detected by built-in test equipment (BITE) and annunciated to the crew for on-condition maintenance actions.

Currently, fiber optics technology is being used extensively by the telecommunications industry; however, fiber optics applications have not yet been used to any extent on a production commercial aircraft. NASA is in a position to implement the merging of industry requirements with evolving technologies to ensure that appropriate hardware development will take place in a timely manner.

The objective of a fiber optic research program should be twofold. First, requirements should be established and relevant fiber optics techniques and components reviewed. Second, a working relationship with the fiber optics industry should be established to ensure that the development of the required components and systems corresponds to milestone requirements of airframe industry schedules. In the past, this type of cooperative effort has produced results far in excess of those resulting from the regular NASA/airframe-contractor budgetary expenditures due to leverage and the use of the subcontractor development funds.

As shown in table 22, fiber optic signaling has other advantages in the areas of weight, information bandwidth and electrical isolation. Current fiber optics system hardware application is hampered by interconnection problems which constrain the practical system layouts. Continued development of optical sensors and improvement in interconnection technology, as defined in section 8.5, will allow the potential of fiber optics to be realized in future commercial transports.

5.6 FLIGHT DECK SYSTEM

5.6.1 APPROACH

The flight deck system trade study was a limited-effort task, sufficient to identify areas in which IDEA features interact with the crew. Much further work is required prior to implementation. For the study approach, a small task team defined a flight deck system concept compatible with the IDEA subsystems. The concept was based on the results of current research and recent experience. Areas addressed included the level of automation in affected subsystems, actuation and display requirements for affected subsystems, and characteristics of the manual control devices. During the study a number of alternative implementations arose, identifying controversial issues which should be resolved through additional research.

5.6.2 IDEA SYSTEM OPERATION

The task team focused on the operation of the airplane systems directly affected by the IDEA concept. These systems include secondary power, environmental control, pressurization, and ice protection. System operation objectives were proposed as follows:

- 1) In normal operation, little or no crew action should be necessary.
- 2) After first failure a subsystem should reconfigure automatically to maintain operation. The crew may be notified by a display advisory.
- 3) Subsequent failures should require only simple crew actions directed by the subsystem indications.

Again, more detailed joint development of the other systems and the flight deck is necessary to ensure that these objectives will be reasonably met in the IDEA configuration design.

5.6.3 GENERAL FLIGHT DECK DESIGN CONSIDERATIONS

Experience has shown that consideration of crew operation early in the system design process can greatly improve total system effectiveness, especially as systems grow in complexity.

The quiet, dark flight deck is one in which the use of attention-getting devices (aurals and annunciation lights) is reserved for conditions that require action by the flight crew. Most of the systems designer's requirements for the flight deck center around control of a system and/or indication of the normal or non-normal state of the system. Control typically takes the form of either discrete or variable (analog) position switches, while indication typically takes the form of either displays or annunciators. Multifunction displays (e.g., CRT, LED, LCD) and controls (programmable legend switches, touch panels, line edit) will provide much more flexibility in display control; however, the quiet, dark concept must still be maintained. Basically this concept means that only non-normal conditions of a system will be "annunciated" by lights, aurals or other fault indications. Indication of normal operation of a system will be provided by a position of indicator or switches without the use of lights (e.g., the position of the controls) and the absence of non-normal annunciations. In other words, the crew will not be expected to detect any non-normal system condition through the absence of a normal indication such as a green light.

5.6.3.1 Crew Alerting

Alerting systems should inform the crew of conditions requiring attention, indicate the criticality, location and nature of the problem, and provide feedback on the adequacy of the aircrew's corrective or compensatory actions as well as the capability to interact with the alerting system. Using a systems approach, the design of future alerting systems should provide unique attention-getting and informing methods for each urgency level. The system should be flexible and possess a capability to accommodate new alerts without requiring additional discrete aural or visual annunciators. To be effective, the alerting system must be highly reliable, activating only when an alerting situation exists. The overall reliability of the alerting system depends on both the reliability of the hardware with its associated logic and on the performance of the pilots. In order to maximize the reliability of pilot performance, different techniques, such as presenting all alerts on a centrally located display, should be studied early in the development of the IDEA flight deck.

For a crew alerting system to be truly effective and handle a very large number of different alerts, the alerts must be prioritized according to what is expected of the crew. As recommended by several studies and industry standardization committees, this is done in terms of how fast the crew must discover or react to a given non-normal condition.

The system used on the Baseline configuration uses the following alert-level definitions:

WARNING – Any operational or subsystem condition which requires immediate compensatory or corrective action.

CAUTION – Any operational or subsystem condition which requires immediate crew awareness and subsequent action.

ADVISORY – Any operational or subsystem condition which requires crew awareness and may require crew action.

The number of WARNING level alerts is inherently limited on any airplane. To satisfy the immediate action requirement, the initial procedure for each warning must be memorized by the crew. Warning level alerts are, therefore, used only when immediate crew intervention is the only reasonable design solution to a system fault condition, and for the purpose of flight safety. A system fault which requires immediate crew action that is too lengthy or too complicated to be easily memorized and executed will be unacceptable.

The use of CAUTIONS and ADVISORIES is less restrictive in terms of maximum number allowed; however, the definitions of these two alert levels, as for WARNINGS, must be interpreted rigorously in terms of operational requirements. CAUTIONS and ADVISORIES must have an associated crew action required and/or a requirement for the crew to be aware of the condition. They will not be used to annunciate conditions which have no effect on crew operations.

5.6.3.2 Status and Maintenance

The engine indication and crew alerting system (EICAS) on the Baseline allowed information other than warnings, cautions, and advisories to be categorized according to use. Two new categories of information which had traditionally been located on various system panels around the flight deck were integrated into EICAS. These are:

Status Information — Used by the crew to determine the dispatch readiness of the airplane. Information presented would include annunciation of many system faults which are dispatch critical, but which are not included as crew alerts because they have no inflight procedure or crew awareness requirement.

Maintenance Information -- Only intended for use by maintenance personnel and normally not even available in flight.

On future airplanes, the meaning and utility of these various categories can be expected to evolve somewhat, but the basic purpose of organizing the information into meaningful blocks will become standard. This kind of categorization is not meant to remove annunciations from the airplane. Any system requirement for an annunciation should fit in one of the established information categories.

5.6.3.3 Automation

Selective use of automation in aircraft systems is highly desirable on two-crewmember flight decks as a means of reducing crew workload. In general, automation is most useful when used to eliminate switch-on or switch-off actions by the flight crew during normal operation and during certain non-normal operations. On the Baseline, systems such as pitot heat, bleed valves, generators, and many others are turned on and off automatically under normal circumstances. Additionally, loads are shed automatically from the electrical system in the event of a generator failure. However, excessive automation should be avoided. It creates interdependence of systems to the point where more systems become dispatch critical. Also, excessive interdependence of systems can result in cascading failures, which would cause much more difficulty for the crew than coping with single failures.

5.6.3.4 Backup Systems

Backup systems are a common requirement for systems which are flight critical, such as control systems. In these cases, it will not be sufficient to rely on crew action to engage the system manually if no clear annunciation is provided as a cue to do so. Even a clear annunciation may not be adequate for some types of backup systems if the required crew reaction time is too short, or engagement of the system too complex. For these backup systems to be activated at the appropriate time, it may be necessary to make the activation automatic.

The minimum requirements for engagement of backup systems are a clear annunciation, time allowed for the crew to accomplish the desired task, and a sufficiently simple task. For most systems, if an annunciation can be provided reliably (as it must be if reliable crew reaction is expected) then the system should also be capable of engaging the backup system automatically.

5.6.4 FLY-BY-WIRE FLIGHT CONTROLS

The IDEA configuration incorporates fly-by-wire (FBW) flight control and eliminates any mechanical control signaling on the airplane. This study area addressed characteristics inherent in traditional flight control system implementations, which are subject to change in future implementations. In this task, the controls affecting flight path were emphasized. Physical characteristics, control feedback characteristics, and trim characteristics were covered. These characteristics can have important cost, weight, and complexity effects on the system, so it is important that requirements in this area are carefully worked in a comprehensive simulation and flight test program.

5.6.4.1 Physical Characteristics

For this study, the selection of alternatives in the physical characteristics of flight controls was based on a Boeing internal research and development program. This program had evaluated Boeing pilot responses to a full-scale mockup of several different control types and configurations. This effort was conducted to scope future flight simulator and test efforts.

The mockup pitch and roll controllers included: 1) a single outboard wrist controller; 2) dual wrist controllers; 3) a console-mounted low-profile wheel; and 4) a center wrist controller. Options 1 and 2 had the pilot preference for first choice while option 3, the low-profile wheel, had the highest second choice preference. Results of the mockup study recommended that a small, properly designed wheel be carried through at least the first stages of simulator evaluation. The study also indicated that the shape of the FBW-device and angle of installation, as well as its force and motion characteristics, are extremely important to pilot acceptance of the device. All evaluation pilots stated that a dynamic simulation/flight test program would be necessary to refine control force/deflection aspects for all the flight path controllers.

The mockup rudder and brake control modules incorporated linear motion characteristics with a smaller displacement (throw) than conventional systems. A dynamic simulation/flight test program will be needed to refine force and deflection characteristics.

The mockup options for the thrust control included both linear and rotary motion levers. There did not appear to be any strong pilot preference for either motion. A lift-to-reverse thrust concept was considered an improvement over present piggyback configurations by the majority of the pilots.

Another concept which interested most of the pilots was automatic flap scheduling. The proposed concept provides for crew selection of "final" flap position with intermediate flap positioning based on sensed air data. The area of specific application (landing and/or takeoff) and functional details require extensive further investigation followed by operational evaluation.

5.6.4.2 Control Feedback Characteristics

Current transports have the traditional, mechanically linked flight control systems. In those systems, the amount of feedback on the control corresponds to the position of the control surface due to control inputs from the other pilot or the autopilot. Straightforward FBW control systems could be very simple if it were acceptable to eliminate the control feedback motion. It is generally accepted that stability and load alleviation function commands with frequencies and magnitudes of no concern to the flight crew need not cause control device motion. On the other hand, pilots evaluated in the mockup study felt that pilot and copilot inputs on the pitch/roll controller and rudder pedals need to be "linked" either mechanically or electrically to provide feedback through the controllers.

The question of whether autopilot command inputs or flight envelope limiting inputs (i.e., stick shaker) need to cause control device motion is controversial. Due to the potential impact on system cost, complexity, operational acceptability, and safety this area must be thoroughly studied in an operational simulation and flight test program.

5.6.4.3 Trim Characteristics

In current aircraft trim action centers the pitch control while leaving the roll and rudder controls in a deflected position. In a basic FBW implementation, all control devices would be centered after control forces were trimmed out. Differences seen by the pilot would be in the roll and yaw control. However, with the basic FBW implementation, crew

awareness of mistrim situations or the crew's ability to detect malfunctions (such as fuel imbalance) would be a concern. Non-normal, engine-out operations have large trim requirements which change with the power setting. The simulation/flight test research program should also address display (i.e., surface position, trim setting) and crew alerting requirements resulting from an FBW flight control implementation.

5.6.5 FLIGHT DECK INTEGRATION

A total flight deck redesign effort was outside the scope of the IDEA systems study. Nevertheless, the IDEA concepts can be used to integrate system control and display devices to great advantage. This integration has the potential to reduce cockpit panel size, weight and number, reduce duplication of input devices, increase reliability, lower cost of ownership, and reduce pilot workload. Recognizing that the limited scope of the study in this area precluded detailed definition and estimation of weight and cost increments, the following paragraphs describe general characteristics of the IDEA flight deck.

Integrated digital electric systems lead the way for future commercial transports with an all-electronic flight deck using fully integrated advanced displays and controls based on digital avionics. Digital entry will be improved as present keyboards are replaced with voice activation, touch panels, and/or changing-legend multifunction keyboards. These latter keyboards will contain improved formatting and more obvious logic trees for manual data entry, recall, and modification of stored data.

The primary flight displays and system status monitors will be high resolution, full color, interchangeable display devices interfaced to be operable as multifunction displays. Provisions will be made for a head-up display system(s).

A set of secondary displays with limited color and resolution requirements could be used. Some displays will have built-in mode and edit buttons around the periphery of the screen. Research is needed to determine the proper number and function of the switches needed to assure interchangeability of displays. Also, the advantages/disadvantages of using identical devices for both primary and secondary displays must be examined.

Proper implementation of multifunction control display panels will result in a significant reduction of the number of control switches on the overhead panel. Some of the standard overhead control panels (i.e., fuel, ECS, electrical) may be totally integrated into multifunction controls; however, most essential controls (i.e., standby power, fuel and ignition, and fire protection) will be retained with computer-controlled, illuminated, pushbutton switches used for most functions. If needed, graphic and alphanumeric information can be displayed in any of the high resolution displays located on the main instrument panels.

A study of flight management control display units (CDU) has concluded that present dedicated hardwired CDU keyboards will be replaced with multifunction keyboards using logic trees for means of manual or voice control data entry, recall, and modification of stored data. These digitally addressed, programmable-legend switches will also be adaptable to new requirements and systems as they become operational.

A typical configuration concept consists of a 15-key (3 x 5) multifunction keyboard below a 10-line display with pre-entry scratch pad and associated line select (edit) keys on either side of the display, as shown in figure 56.

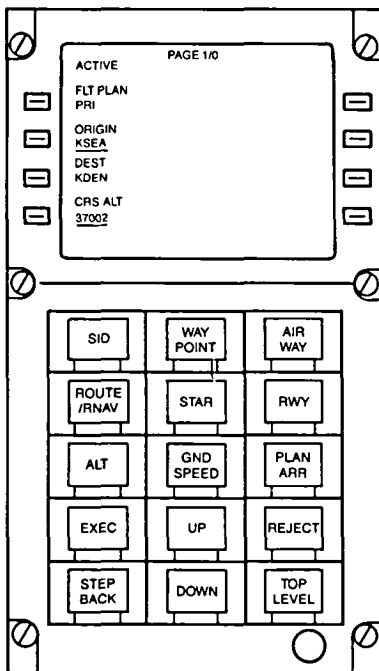

Figure 56. CDU Multifunction Keyboard

One concept for the incorporation of multifunction keyboard control and display units calls for three units for the crew interface. Each unit would operate with any system; however, during operation each unit would be configured for a specific function (i.e., flight management, communication/navigation, systems management).

Careful consideration must be given to the proper integration of crew capabilities with system operation. Research and development programs must address the human interface questions which will arise with the application of the new digital electronic technology. The research and development necessary to bring the new flight deck concepts to reality constitute a long-term project. There are a variety of aspects to examine. Human factors and the concerns about operation of the new devices in normal and non-normal situations must be addressed. Operation under fault conditions leading to cascading malfunctions must be evaluated. Specific logic tree designs should be evaluated for crew attention requirements in operational environments including non-normal situations.

Flat panel display technology development should be encouraged. Currently, the high resolution display requirements can be met only by CRT devices; however, flat panel technology, once developed, can dramatically reduce volume, weight, cooling, and cost if developed to satisfy display requirements.

5.7 ENVIRONMENTAL CONTROL SYSTEM

5.7.1 ECS STUDY CYCLE CONFIGURATIONS

For the IDEA Airplane, an electrically driven ECS air source was a ground rule requirement. The prime study goal was to reduce power consumption without compromising Baseline performance requirements. With these guidelines in mind, the four IDEA ECS study configurations shown in table 25 were established. All utilize an electrical motor-driven compressor system to boost ram air pressure for supply to two packs.

Table 25. ECS Study Guidelines and Configurations

Options	Air Source	Compression Method	Thermal Conditioning Pack	Cycle Heat Sink
Baseline	Engine Bleed		Air Cycle	Ram Air
Study Configuration ①	Ram Air	Electrically Powered Compressor	Air Cycle Plus Heat Exchanger Cooling	Ram Air
2	Ram Air	Electrically Powered Compressor	Vapor cycle	Ram Air and Fuel
③	Ram Air	Electrically Powered compressor	Vapor Cycle	Ram Air
④	Ram Air	Electrically Powered Compressor	Air Cycle	Ram Air

Prime Study Items

- Key constraint: No bleed air available from engine
- Goal: Reduced power consumption while meeting baseline performance

Study Configuration 1 (air cycle/HX cooling) uses air cycle packs with bypass provisions for heat exchanger cooling. This system takes full advantage of cooling from ram air at ambient conditions where this mode is effective, by bypassing airflow around the air-cycle machine and high-pressure air/water separator loop. The result is decreased

pack pressure requirements due to bypass of the turbine, heat exchanger and separator components. Decreased pressure requirements reduce air source compressor power consumption. The Baseline ECS uses engine bleed air to supply the packs. Maximum use of engine bleed air is obtained by operating the air cycle machine and reducing ram air usage.

Study Configurations 2 and 3 (vapor cycle/fuel and vapor cycle) utilize vapor-cycle air conditioning packs. After the air is precooled by the ram air heat exchangers, it is further cooled by a mechanical refrigeration cycle during the cooling mode of these configurations. Configuration 2 uses fuel as a heat sink for the vapor cycle condenser when available, and configuration 3 makes use of only ram air for this purpose. Since configuration 2 is a more complex version of configuration 3, further study is considered dependent upon results from configuration 3. Configuration 4 (air cycle) utilizes baseline packs and ram air compressed by electrically powered compressors.

5.7.2 EQUIPMENT CONFIGURATIONS

Location of the air source system, air conditioning packs and electrical converter and its cooling system are common for all four IDEA ECS study configurations. The ECS air source system consists of a ram air inlet, ducting, air compressors, electric motors, an equipment-cooling subsystem, and air supply ducting and valving.

To gain the maximum benefit of ram air, the air source system is located in the nose of the airplane. The nose-mounted ram air scoop and inlet ducting to the compressors can be expected to have a pressure recovery of 85%. This is significantly better than a body-mounted location, where ram pressure recovery is on the order of 65%. The nose location results in lower compressor pressure ratio requirements and, hence, lower power requirements. High efficiency samarium cobalt electric motors are selected to drive the compressors. A variable speed compressor, controlled by variable voltage and frequency supplied to the motor, is chosen for the benefit of matching performance to airflow and pressure requirements. In addition to supplying air to the ECS compressors, the air inlet ducting provides cooling air to parallel air/oil heat exchangers used to cool the motors. A fan located downstream of the heat exchangers induces airflow during ground operation and low speed flight. Isolation valves are required downstream of the compressors to prevent reverse flow through a nonoperating compressor.

Dual air supply ducting from the air source system to the air conditioning packs is used to provide redundant air supply. Two packs are located beneath the wing box of the IDEA Airplane. This is the same location utilized by the Baseline. The IDEA ECS air distribution system is also identical to that of the Baseline.

The four motor-power converter-starter controller units (three are used for ECS compressors) are installed in the body of the airplane forward of the packs. They are cooled with four parallel air/oil heat exchangers mounted in a single inlet duct that includes a fan for ground operation and low-speed flight.

A system utilizing three operating compressors is chosen for optimum performance and load penalty. A two-compressor system would require that airplane dispatch be dependent upon the operational capability of the compressors. (The APU does not supply pneumatics.) A comparison study of an alternate compressor system with two operating compressors and one redundant compressor (see figure 57) showed that 50% larger compressor and motor sizing would be required for the alternate air source system with little benefit realized. The alternate system would be heavier, more costly, require additional control complexity, and require a larger inlet and cooling subsystem.

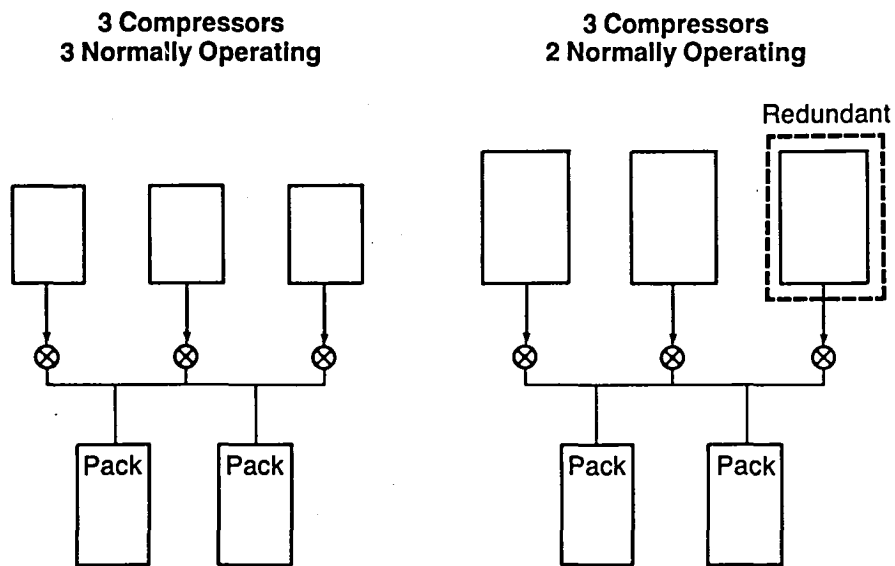

Figure 57. ECS Study Compressor Configurations

5.7.3 PERFORMANCE COMPARISON

As stated earlier, a basic goal of this analysis is to minimize the electrical load of the motor/compressor by identifying a configuration with reduced compressor pressure ratio requirements. For ECS study configurations 1 and 4 (air cycle/HX cooling and air cycle), the motor/compressor load is by far the largest component of the total load.

An ECS simulation computer program was used to predict system performance and identify system requirements for air cycle and heat exchanger cooling pack operation. In addition to the above mentioned cabin requirements and 85% inlet pressure recovery, the three IDEA system studies used the same pack duct-pressure-loss parameter as that of the baseline airplane (i.e., applied downstream of the precooler to the flow control valves). A maximum compressor adiabatic efficiency of 80% is assumed. Sensible and latent heat load for 197 passengers plus crew was used in the analysis.

Required compressor discharge pressure is shown in figure 58. About 1-1/2 PSI separates standard and hot day pressure requirements for operation of the three-compressor air source with Baseline air conditioning packs, study configuration 4. Considerably lower

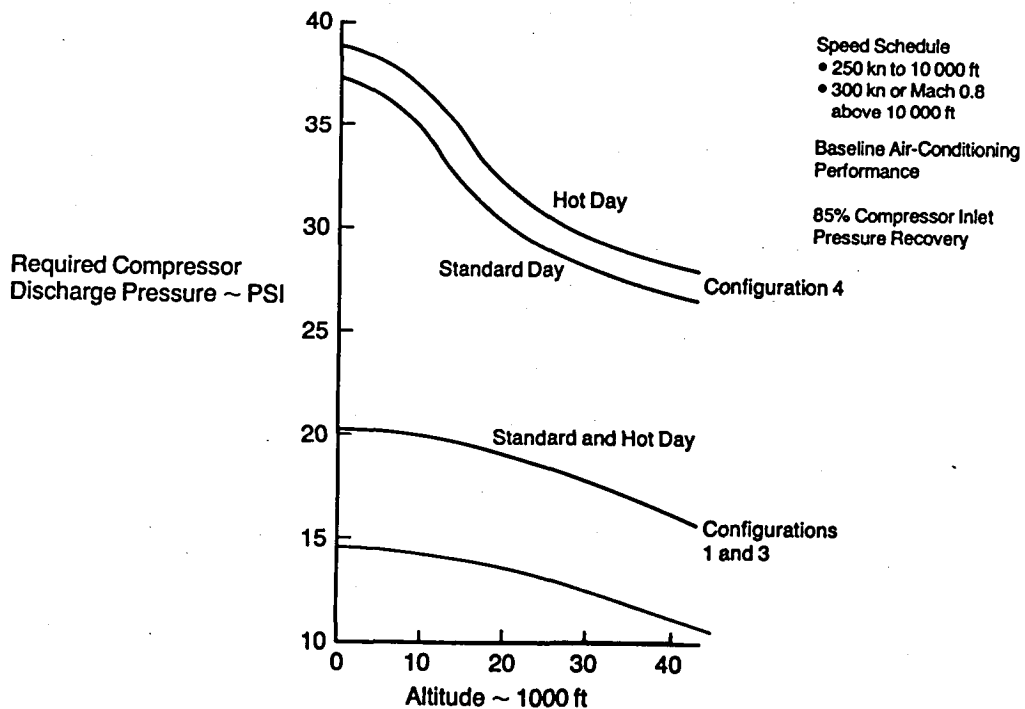

Figure 58. ECS Pressure Requirements

pressure is needed for pack operation and cabin pressurization for the system using heat exchanger cooling and the vapor cycle system, configurations 1 and 3. Requirements for standard and hot days are the same. Note that the curve reflects pressure requirements for heat exchanger cooling over the entire operating range. The resulting cabin temperature may exceed 75°F. No distinction is made for applicability of this type of cooling for lower operating altitudes. As shown in the figure, a large drop in required pressure is available relative to configuration 4 (air cycle). The difference between the required pressure curves and the cabin pressure indicates the pressure needed to overcome duct and pack resistance and to provide the required cooling performance. Maximum operation on the lower required pressure curve is a goal of this study.

Figures 59 and 60 depict the cabin cooling requirements for a standard and a hot day, respectively. The bottom curve in each case shows the mix manifold temperature required to meet Baseline performance. The curve is derived from simulation program data for study configuration 4 (air cycle). The deviation from linearity at lower altitude

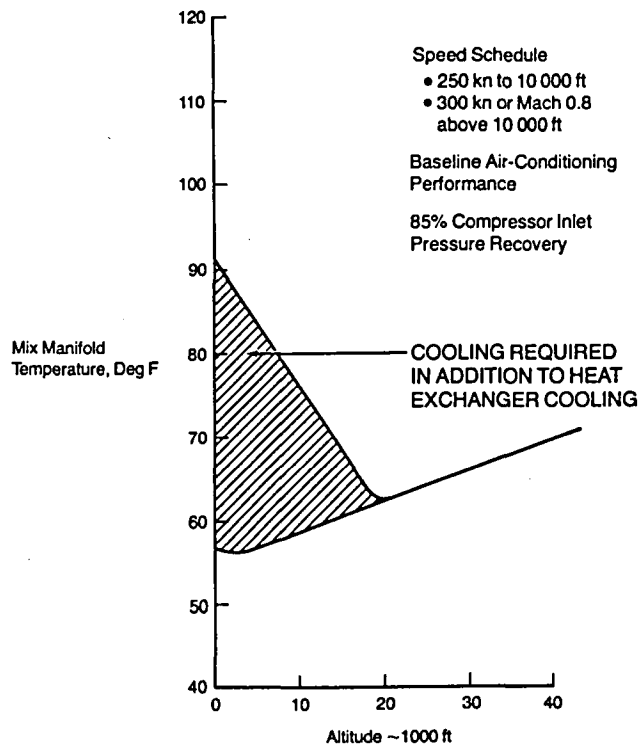

Figure 59. ECS Cabin Cooling Requirements—Standard Day

reflects a cabin temperature greater than 75°F during transient operation. The upper curve in each figure gives the temperature at the mix manifold resulting from cooling by the heat exchangers (precooling). The cross-hatched area represents conditions where additional cooling is required. As expected, a greater amount of additional cooling is required for hot day operation than for standard day operation. The difference quantitatively indicates the additional cooling of the air supplied to the cabin required by some other means. This may be accomplished by air cycle or vapor cycle cooling. The study also showed that parallel operation of the heat exchanger cooling mode with air cycle operation (with flow through the air cycle machine) provided no additional cooling and that the heat exchanger bypass valve should be either open or closed, as opposed to modulating. Further study is required to determine the required interaction of the heat exchanger cooling bypass valve, temperature control valve and ram air door.

In considering study configuration 1, air cycle with heat exchanger cooling capability, the cooling requirements curves in figure 62 show that the packs can be switched from air cycle to heat exchanger cooling at about 18,000 feet during standard day operation. The

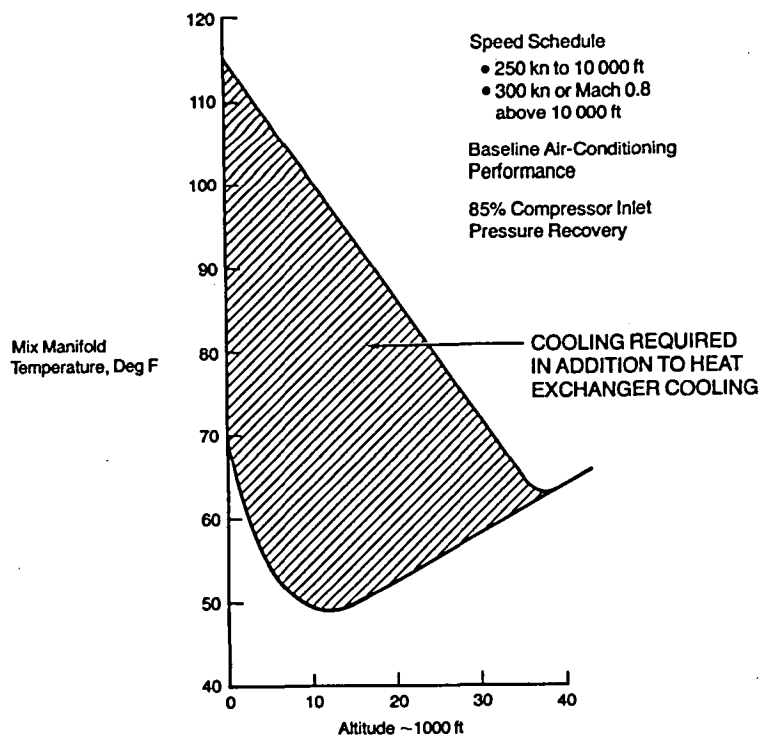

Figure 60. ECS Cabin Cooling Requirements—Hot Day

"switch-over" altitude for hot day flight is near 35,000 ft. Above these altitudes, ambient ram air is sufficiently cold to provide an adequate heat sink to cool the fresh/recirculated mixed air supplied to the cabin. (The fresh air supplied by the air source subsystem is heated by compression.) Reduced pack pressure requirements during this operation result in a savings on fuel burn relative to full air cycle operation. Below these "switch-over" altitudes, ram air does not provide an adequate heat sink for cooling down to the required mix manifold temperature. Total heat exchanger hot-side effectiveness approaches 99%, and the difference between the hot side-exit temperature and the cold side-inlet temperature is near 1°F during this operation. It is apparent that further improvement in heat exchanger performance is not possible through increased heat exchanger or inlet size or by reconfiguration of the ram air side.

Figure 61 presents a representative compressor performance map for study configuration 1. Standard and hot day compressor airflow, corrected to inlet conditions, vs compressor pressure ratio is plotted for typical flight conditions. Note the sharp drop in required pressure ratio when the air conditioning packs are switched to heat exchanger cooling.

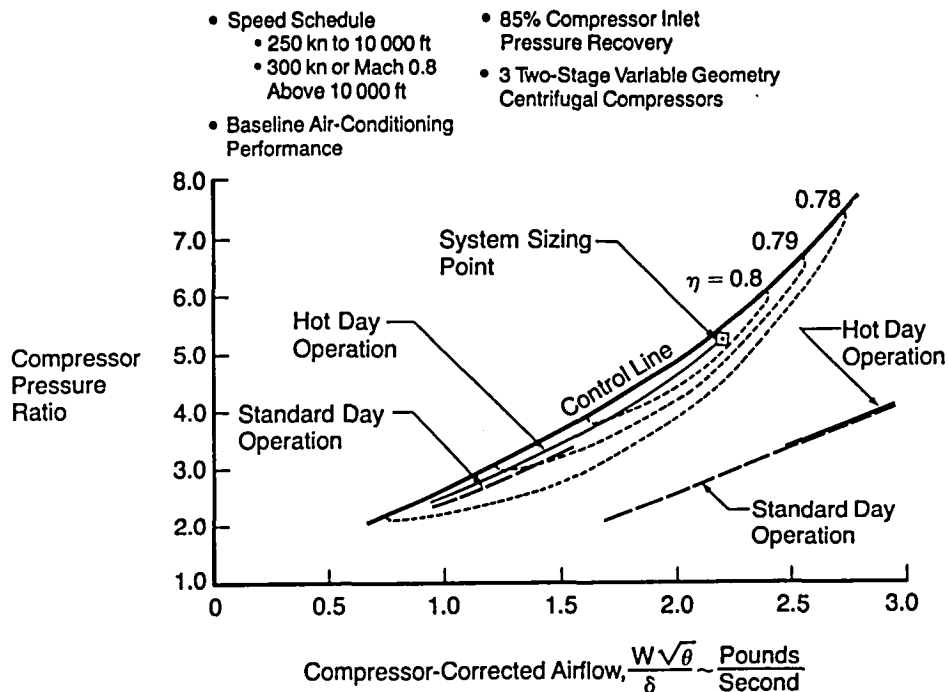

Figure 61. Representative Compressor Map—Study Configuration 1

The system sizing point is shown at the maximum required pressure ratio of 5.2. This condition necessarily sizes the ECS compressor and electrical motor and is considered in the design and sizing of the IDEA electrical system. A two-stage centrifugal flow compressor is selected for its operational stability.

A typical fixed-geometry-type control line and compressor efficiency islands are shown for air cycle pack operation. Use of a compressor with variable geometry, with inlet guide vanes or a variable diffuser, will permit both compressor operation at peak efficiency and reduced surge bleed loss for further load reduction. The effect of variable compressor geometry is to translate the control line and efficiency islands to the right, as shown in figure 62, as needed. The effect of this for 39,000-ft standard day operation is to increase compressor efficiency from about 55% to 80% for fixed and variable geometries, respectively. This reduces total compressor load by nearly a third.

Air cycle ECS performance (configuration 4) is evaluated with efficiencies as shown in figure 61 with the control line placed for optimum operation. Vapor cycle packs (configuration 3) are supplied by three compressors with the same characteristics and performance as shown in figure 61.

One of the main system selection criteria is reduced ECS electrical load. For air cycle (configuration 4) and air cycle with heat exchanger cooling capability (configuration 1), operation of the three motor/compressors and two recirculation fans constitutes the load. During ground cooling the motor cooling subsystem fan load and the converter/controller cooling subsystem fan load are also included. In addition to the above compressor and fan loads, the vapor cycle configuration requires refrigerant compressor motor operation for each of the two packs and power for the heat exchangers and vapor cycle condenser fans during ground cooling.

ECS power requirements for the three study configurations can be compared in figure 62. Required compressor input power, the largest individual ECS load, is plotted. These loads do not include power losses due to inefficiencies in the electrical system (generator, line, connector, motor losses). The compressor loads are based on the pressure requirements, cabin cooling requirements and compressor efficiencies detailed in earlier figures. Vapor cycle performance is based on refrigerant R114. Compressor loads for air cycle ECS are represented by the upper two curves for hot- and standard-day missions. The heavy and broken lines range from sea level to 43,000 ft.

When heat exchanger performance is added above the appropriate 18,000- and 35,000-ft "switch-over" altitudes, it results in configuration 1 (air cycle/HX cooling) power requirements as shown on the graph (the heavy curve). The vertical lines indicate the change of pack operating mode when the heat exchanger bypass valve opens (during ascent), thus deflecting airflow away from the air cycle machine. The power savings due to reduced pack operating pressure are clearly shown. The hot day hold system sizing condition is plotted at just over 350 hp.

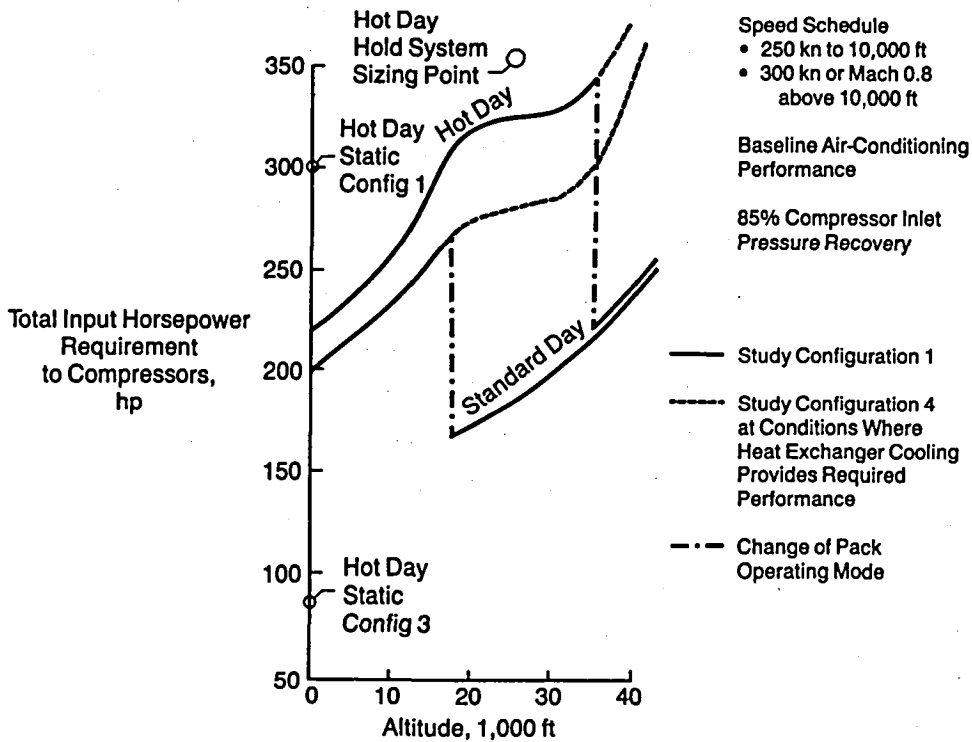

Figure 62. ECS Power Requirements

Compressor load for the vapor cycle sizing condition of hot-day ground static operation represents one-third of the total required ECS load for the vapor cycle at the user level. The corresponding load for the air cycle configuration is also shown in figure 62.

5.7.4 ECS CONFIGURATION SELECTION AND DESCRIPTION

Total power requirements at the user level and a weight and cost comparison are presented in table 26. The user level is defined as the interface between the electrical and ECS systems (i.e., compressor motor and fan motor inputs). Configurations 1 and 4 (air cycle/HX cooling and air cycle) utilize air cycle thermal conditioning during hot day static cooling. This 352-hp user load compares to 235 hp required to drive the vapor cycle in configuration 3, or a power savings of one-third with the vapor cycle. At a 39,000-ft standard day cruise, air cycle operation needs 395 hp, while a savings of one-third is realized during heat exchanger cooling operation with configurations 1 and 3 (air cycle/HX cooling and vapor cycle). Therefore, from an ECS load standpoint, which ultimately translates to fuel burn from generator extraction off the engine, the vapor cycle configuration 3 is preferred. Heat exchanger cooling modification to the Baseline air cycle pack also results in favorable load efficiency.

Summary table 26 also allows weight and cost comparison of the three IDEA ECS study systems. Environmental control system modifications from the Baseline engine bleed air supply to a no-bleed electric ECS results in 1,060 lb of additional system weight. Forty pounds of pack modification is needed to provide heat exchanger cooling power reductions. An additional 220 lb of ECS system weight would be needed to provide vapor cycle packs. Since three straightforward bypass modifications are required to provide

Table 26. ECS Study Comparison Summary

	TOTAL POWER REQUIREMENT *		SYSTEM WEIGHT (LB)	INSTALLED COST
	Sea Level Hot Static Day	39 000 ft Standard Day Cruise		
BASELINE	---	---	2280	---
STUDY CONFIG. 1	352 Horsepower	272 Horsepower	3380	Comparable
STUDY CONFIG. 3	235	272	3600	Higher
STUDY CONFIG. 4	352	395	3340	Base

* At User Level

heat exchanger cooling; installed cost for configurations 1 and 4 (air cycle/HX cooling and air cycle) are very similar. However, the addition of the refrigerant loop and its added components results in a comparatively higher cost for the vapor cycle configuration 3. Due to the favorable reduction in pressure-load requirements and nonprohibitive system weight and cost, ECS study configuration 1 (air cycle/HX cooling) was selected for the IDEA Airplane. However, since the vapor cycle ECS offers attractive benefits, with further analysis either configuration 2 or configuration 3 could prove to be a more viable system for an all-electric aircraft.

A schematic representation of the selected air cycle with heat exchanger cooling arrangement is shown in figure 63. The three-compressor air source subsystem is shown on the left with 120-hp samarium cobalt electric motors and two-stage, shaft-driven centrifugal compressors also rated at 120 hp.

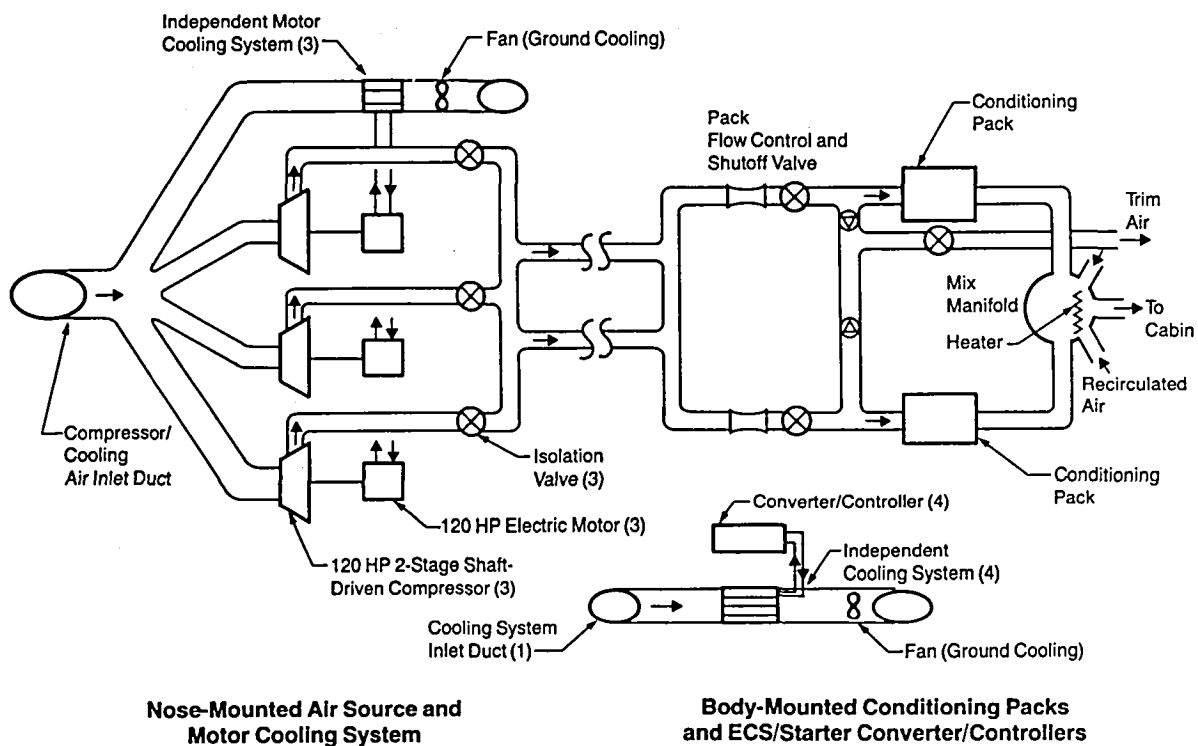

Figure 63. Selected ECS System—Study Configuration 1

Generalized air conditioning pack and air distribution is shown on the right half of the figure. The body-mounted ECS converter/controller, which provides the dual function of controlling engine starting, is depicted at the bottom of the figure with its air/oil cooling subsystem.

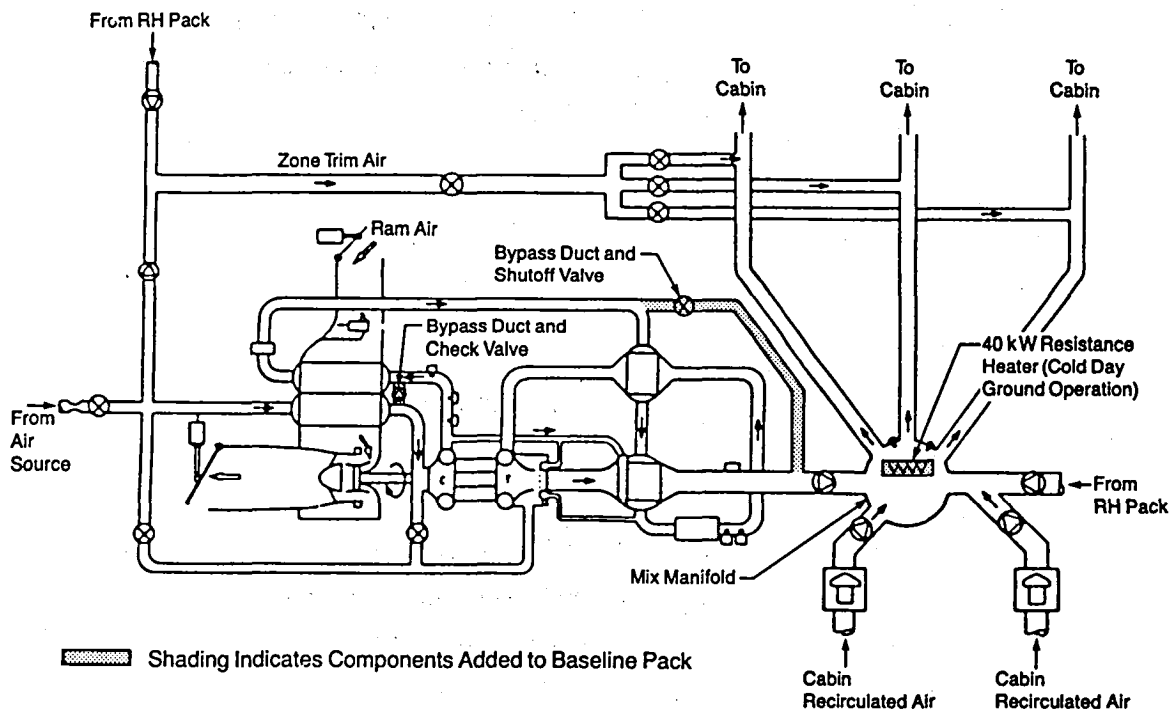

Figure 64. Air Conditioning Pack Schematic—Study Configuration 1

The selected pack arrangement is given in figure 64. Four components are added to the baseline pack to provide the required capability. They are:

- 1) A system bypass duct and two-position valve
- 2) An air cycle machine (ACM) bypass duct and check valve
- 3) A 40-kW electric resistance heater
- 4) A ram air inlet fan bypass valve

The 40-kW resistance heater is required for cabin temperature "pullup" during cold day ground operation. The fan bypass valve is required to avoid an undesired pressure drop across the fan and ejector during heat exchanger cooling mode when the ACM is not operational. Without the valve, cooling ram airflow would decrease due to the higher pressure drop across the fan/ejector that would result from the interaction of the air with the fan blades.

5.8 ICE PROTECTION SYSTEM SELECTION

5.8.1 OBJECTIVE

The objective for this portion of the IDEA study is to select the best ice protection system (or systems) expected to be available by the 1990s. As a general ground rule, the system cannot require the use of engine bleed air.

5.8.2 SELECTION CRITERIA

The criteria used for selection are:

- (1) The system must have a high probability of certification under present and foreseeable FAR rules.
- (2) The system must be consistent with the IDEA concept. As stated in section 5.8.1, it cannot use hot air derived from engine compressor bleed. As with the other systems of the IDEA concept, it should also lend itself to digital electronic control.
- (3) The system must be compatible with fully automated operation. Sensors should make the decision to operate the system under the normal operating environment. A manual override would be provided for dispatch considerations.

5.8.3 SYSTEM OPTIONS

In table 27, several candidate options for ice protection systems are presented with their applicable areas of protection and potential operating modes. Each option, its major advantages and disadvantages, as well as the reason for selection or rejection will be described. Although ideally anti-icing (prevention of ice formation) would be preferred to de-icing (removal of ice after formation) to maintain clean air flow, the necessary technology is not yet in sight. As stated briefly in the following paragraphs, anti-ice operation was rapidly ruled out as a possibility, mainly by the selection criteria. In table 28 candidate systems are compared with the Baseline for power requirements and weight.

Table 27. Ice Protection Candidate Systems

Cowl		Wing	
Mode	Concept	Mode	Concept
Anti-Ice	Thermo-Electric Chemical Thermo-Pneumatic	Anti-Ice	Thermo-Electric Chemical Thermo-Pneumatic
De-ice	Electro-Impulse Thermo-Electric Thermo-Pneumatic Chemical	De-ice	Electro-Impulse Thermo-Electric Chemical Pneumatic Boot Thermo-Pneumatic

Table 28. Weight and Energy Impacts

Option	Total Airplane System Weight*		Energy Requirements	
	Cowl (lb)	Wing (lb)	Cowl	Wing
Thermo-Pneumatic	76	90	1.0 lb/sec at 340° F	1.02 lb/sec at 340° F
Thermo-Electric	116	150	55 kW	18 kW
Electro-Impulse	106	206	0.85 kW	0.85 kW
Chemical (Glycol)		240		0.75 kW

* Installed Equipment Weight

5.8.3.1 Pneumatic Boot

The pneumatic boot system consists of a rubberized exterior surface that can have sections inflated. When the boot is inflated, the ice fractures and is carried away by the aerodynamic forces. This system was used on piston engine transports and is still used on general aviation aircraft. It has two main disadvantages. It is a de-icing system, and it has a severe operating limitation. If the ice is too thin or too thick, the system will not de-ice the surface. Because of the operating limitation, this system was eliminated.

5.8.3.2 Thermo-Pneumatic

The thermo-pneumatic system is very similar to the Baseline engine bleed system. The difference is the hot air source. Several hot air sources were considered, with a compressor and electric heater being selected as the most promising. In this system outside air is drawn in, compressed to the required pressure, heated to the required temperature by electric resistance heaters, and distributed similarly to the Baseline system through spray tubes.

This system can be designed as an anti-icer or a de-icer and can be placed in the cowl and the wing. The system similarity to present bleed air systems is a major advantage, while the major disadvantage is high power consumption. Since preliminary analysis showed that the electrical power required approached the total power generated in the Baseline airplane, this system was eliminated.

5.8.3.3 Thermo-Electric

The thermo-electric system consists of an electric resistance heater embedded in the structure to be protected. The heater consists of a thin wire grid or metallic foil grid embedded in an electrically nonconducting material.

Although the system can be designed as an anti-icer, power requirements usually dictate that the system be designed as a de-icer. The system can be installed in both the cowl and the wing.

A major advantage is that the system energy input can be tailored to meet the requirements of the actual icing encounter as detected by sensors. Its major disadvantage

is the high electrical power requirement, even if designed as a de-icer. Since this system had no significant weight advantage it was eliminated due to the high power consumption.

5.8.3.4 Chemical

The chemical system consists of a freezing point depressant pumped and distributed over the surface to be protected. The hardware required is a tank, pumps, filters, a distributing unit, exuding panels, and tubing to connect these pieces. The exuding panels form the skin of the aircraft at the protected area.

The system can be designed as a de-icer or an anti-icer and is suitable for installation on the cowl and the wing.

The advantage of this system is that the power consumption is very low. The major disadvantages are weight (due to fluid tankage), logistics requirements, and contamination of aircraft components. The contamination of components eliminated this system from consideration.

5.8.3.5 Electro-Impulse

The electro-impulse system consists of a series of coils placed behind the leading edge, but not touching the leading edge. An electrical pulse of high voltage and current is passed through the coils, generating a powerful magnetic field which, in turn, generates a repulsive force in the skin of the aircraft. This force causes the skin to flex, breaking ice accumulations into ice particles which are then removed by aerodynamic forces. Since the system operation removes ice accumulation by breaking it from the structure, it is usable only as a de-icer. It is suitable for both cowl and wing installation. The peak strain induced in the skin is a critical design parameter. It must be high enough to produce the proper de-ice performance but low enough to prevent fatigue within the expected lifetime cycles of the systems, judged to be on the order of 10,000 cycles.

The continuous power consumption is very low due to two facts: not all the coils are pulsed at once, and the pulses come from a discharging capacitor. The major disadvantage is that this system does not keep the surface 100% clean. However, the system meets all of the selection criteria in section 5.8.2. It was selected for the IDEA Airplane because of its low power consumption.

5.8.4 SYSTEM DESCRIPTION

The electro-impulse de-icing system consists of electromagnetic coils placed next to the leading edge as shown in figure 65. These coils consist of wound ribbon wire and can be formed to match the contours of the skin. The spacing of the coils is optimized to provide maximum ice removal.

Electrical power is stored and controlled by a microprocessor-based circuit in the storage and control unit. The ice thickness detector sends a signal to this control unit when the ice thickness reaches the optimum value for de-icing. The control unit then energizes the coils in a programmed sequence by triggering the rectifier pulse release units.

When the coil is pulsed, its strong electromagnetic field produces eddy currents in the skin which create a secondary opposing field and a repulsive force between the coil and skin. The net result is the formation of a single, complex, high-frequency pressure pulse in the skin, which fractures the ice into small pieces. A second pulse breaks the ice-skin bond, allowing aerodynamic forces to carry the ice particles away.

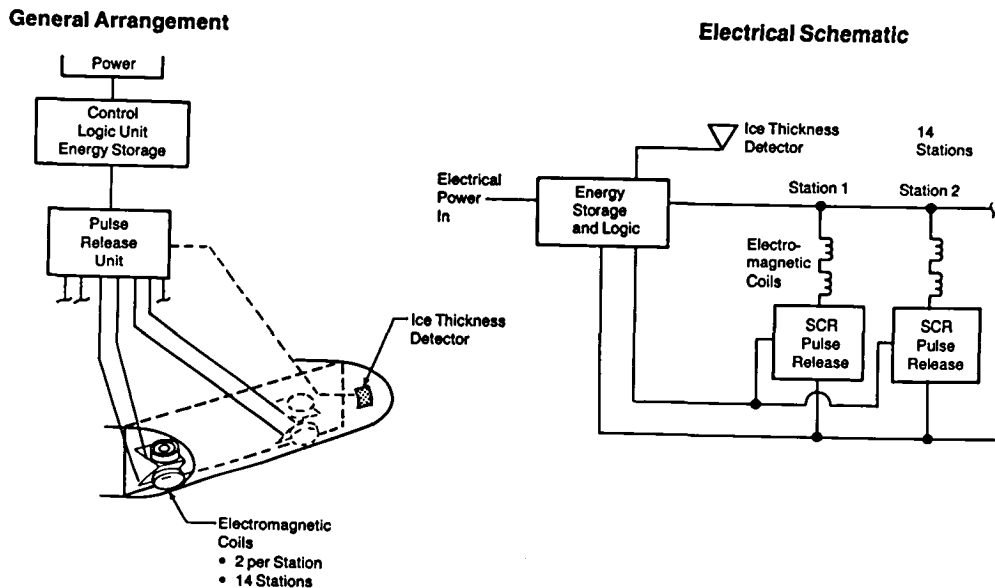

Figure 65. Electro-Impulse System

5.8.5 SYSTEM ADVANTAGES, DISADVANTAGES, AND RISK CONSIDERATIONS

The electro-impulse system advantages and disadvantages are listed in table 29. The technical risks are listed in table 30.

Table 29. Electro-Impulse System Advantages and Disadvantages

Disadvantages	Advantages
<p>De-ice capability only</p> <p>System weight penalty</p> <p>Surface quality less than 100% clean</p> <p>Possible effect on cabin acoustics</p>	<p>Low electrical energy consumption</p> <p>Fractures ice into small particles</p> <p>Compatible with composites</p> <p>Ambient-temperature operating environment</p> <p>Commonality of components/electronics with wing and cowl</p> <p>Compatible with ice detector primary control</p> <p>Requires no engine-bleed air</p>

Table 30. System Technical Risks

Wing	<ul style="list-style-type: none"> ● Aerodynamic performance must account for residual ice on wing surface ● Electromagnetic acoustic levels must meet cabin noise requirements ● Electromagnetic maturation sufficient to analytically characterize operation and performance
Cowl	<ul style="list-style-type: none"> ● Engine design must be compatible with regularly scheduled ice particle ingestion ● Development of ice thickness detector

5.8.5.1 Advantages

One of the advantages listed in table 29 requires an additional comment. The electro-impulse system fractures the ice into small particles. Because the engine will be ingesting some of these particles, this gives a decided advantage over electro-thermal systems, which shed the ice in larger particles. Also, the system can be made compatible with composite structure by placing a metal doubler in front of the coil. This is an important point since pneumatic thermal systems cannot be used with composites and electro-thermal systems can degrade some composite materials.

The system is compatible with an ice detector in primary (automatic) control. Since the best performance is limited to a certain ice thickness range, an ice detector control becomes highly desirable.

5.8.5.2 Disadvantages and Technical Risks

The electro-impulse system does not leave the surface 100% free of ice after de-icing. This trait is dependent upon structural design and can be minimized. Certification with simulated residual ice would be done to determine the aircraft handling characteristics.

The possible effect on cabin acoustics must be considered. Preliminary testing will determine the system impact on cabin noise.

The engine must be able to ingest ice particles. The engine manufacturers will be consulted for maximum particle size and frequency of ingestion.

The development of an ice thickness detector is required.

5.9 WEIGHT, PERFORMANCE, AND ECONOMICS

5.9.1 WEIGHT

5.9.1.1 Weight Analysis

The weight increments for the various IDEA systems were calculated using techniques consistent with methodology used on Boeing's commercial airplanes. Vendor-supplied component data were used where applicable.

The systems that were modified include flight control, actuation, electrical, data distribution and associated avionics, ECS, and ice protection. Table 31 is a weight summary listing the effects of system changes on the equipment and wire weights.

Tables 32 and 33 list system weight changes under three major categories: weight changes associated with the removal of the hydraulic system, weight changes associated with the removal of the pneumatic system, and weight changes associated with the integration of avionics and the incorporation of a data bus system.

Table 31. Weight Summary-IDEA Baseline vs IDEA-Based Systems

Total Systems Delta Weight (lb)		-3180
Equipment Delta Weight		-1740
Remove Hydraulic System	-2480	
Revise Surface Control System	- 20	
Revise Landing Gear/Thrust Reverser Control	0	
Revise Electrical Power System	+ 850	
Revise Avionics System	- 70	
Remove Pneumatic System	- 820	
Revise Environmental Control System	+1080	
Revise Anti-Ice System	+ 40	
Revise Engine Starting System	- 90	
Revise Auxiliary Power Unit	- 230	
Wire/Support/Connectors Delta Weight		-1440
Data Bus Control System	-1250	
Double Voltage Power/Distributed Load Centers	- 40	
Remove Hydraulic/Pneumatic Wire	- 150	

Table 32. Systems Delta Weight Details

Remove Hydraulic System (lb)	Remove Pneumatic System (lb)	Integrate Avionics (lb)	Wire (lb)
Hydraulic Equipment -1840	Pneumatic Equipment -820		Signal Wire -1250
Surface Control Hydraulics -640	ECS Equipment +1080		Power Wire -40
Surface Control Actuation -20	Anti-Ice Equipment +40		Remove Hydraulic/Pneumatic Wire -150
Gear/Reverser Controls 0			
Electrical Power Flight-Critical Equipment +400	Electrical Equipment +450		
Data Bus Control System +260		Instrument/Flight Control Electronics -260 Navigation System Equipment -70	
	Start System -90 APU -230		
Totals: -1840	+430	-330	-1440

Table 33. Weight Summary Major System Changes

Airplane systems Delta Weight (lb)	-3180
Equipment	-1740
Remove Hydraulic System Effects	-1840
Remove Pneumatic System Effects	+ 430
Integrate Avionics LRU	- 330
Wire/Support/Connectors	-1440

5.9.1.2 Weight Statement

A weight statement showing the comparison between the baseline configuration and the IDEA configuration is contained in table 34. Weight distribution within individual groups is consistent with aerospace industry practice (ref. 4). The comparison shown includes the cycling effect (same payload capability) of the reduced systems weight.

Table 34. Weight Comparison

	Baseline Configuration (lb)	IDEA Configuration (lb)
Wing	35,310	35,160
Horizontal Tail	1,620	1,620
Vertical Tail	3,550	3,550
Body	32,160	32,090
Main Landing Gear	12,680	12,380
Nose Landing Gear	1,920	1,880
Nacelle and Strut	4,270	4,100
Total Structure	91,510	90,780
Engine	13,000	12,420
Engine Accessories	270	240
Engine Controls	180	130
Starting System	100	0
Fuel System	1,240	1,190
Thrust Reverser	3,000	2,810
Total Propulsion System	17,790	16,790
Instruments	1,450	1,370
Surface Controls	4,400	3,430
Hydraulics	1,970	0
Pneumatics	840	0
Electrical	2,610	2,930
Electronics	1,760	1,500
Flight Provisions	820	810
Passenger Accommodations	14,730	14,630
Cargo Handling	2,690	2,650
Emergency Equipment	1,020	990
Air Conditioning	2,280	3,380
Anti-Icing	250	410
Auxiliary Power Unit	1,380	1,200
Total Fixed Equipment	36,200	33,300
Exterior Paint	150	150
Options	2,000	2,000
Manufacturer's Empty Weight	147,650	143,020
Standard and Operational Items	13,030	13,030
Operational Empty Weight	160,680	156,050
Passenger Count	(18/179) 197	(18/179) 197
Engines (Qty/Designation)	Advanced Turbofan	Advanced Turbofan
Engine Thrust (SLS)	38,000	36,460
Cargo Containers (Qty/Type)	22/LD-2	22/LD-2
Maximum Zero Fuel Weight	218,230	213,600
Maximum Landing Weight	236,230	231,600
Maximum Flight Weight-Flaps Up	268,040	260,980
Maximum Taxi Weight	269,040	261,980

5.9.1.3 Center-of-Gravity Management

A center-of-gravity analysis was performed on the IDEA configuration, consistent with the level of detail available from the weight analysis. The center-of-gravity management diagram is shown in figure 66. Configuration dimensions have been held constant throughout this study. The center-of-gravity limits are, therefore, the same as those for the Final ACT configuration (ref. 3). Within these limits, the IDEA Airplane exhibits satisfactory loading characteristics.

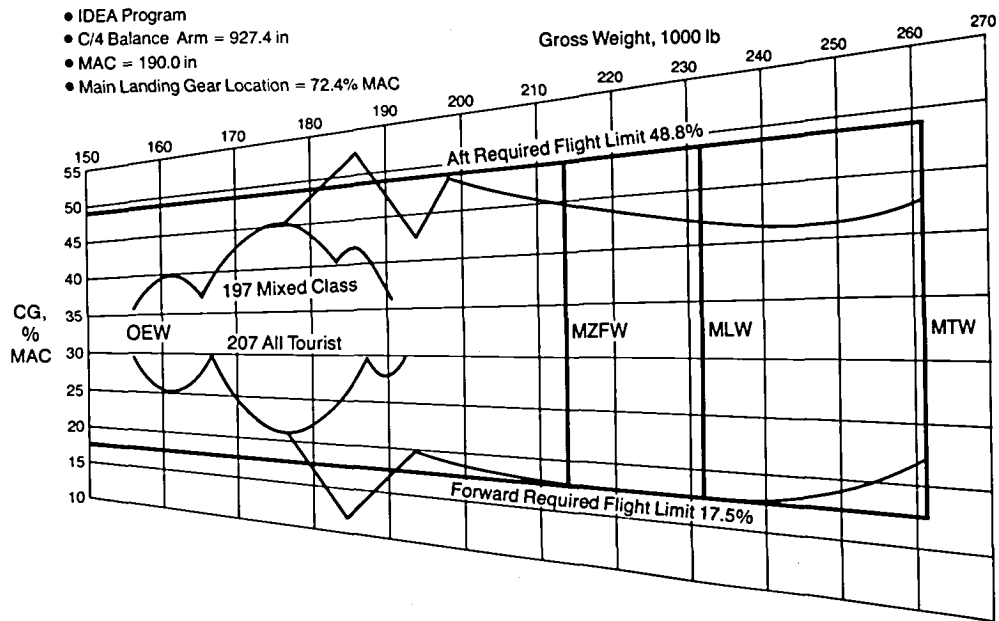

Figure 66. IDEA Configuration Center-of-Gravity Limits

5.9.2 AIRPLANE PERFORMANCE

The IDEA systems described previously were incorporated into the Baseline airplane with no changes in other areas of technology (aerodynamics, propulsion, and structures), and the airplane was resized to the same payload range capability. A configuration performance comparison is shown on table 35. The major differences are reductions in takeoff weight, empty weight, engine size (due to elimination of bleed air extraction), and fuel burn per passenger of about 3%. Cruise efficiency is about 2% better due to the lower specific fuel consumption with no bleed air extraction in cruise. Takeoff field length and landing approach speed capabilities are essentially unchanged. Of the 3% reduction in fuel burn, about 2% is due to the all-electric systems and about 1% is due to replacing bleed air extraction with shaft hp extraction.

Table 35. Baseline and IDEA Configuration Performance Comparison

- Design Range = 4006 nmi
- 197 Passengers
- Cruise Mach = 0.80

	Baseline	IDEA-Based	Increment, %
Max Brake Release Gross Wt, lb	268 040	260 980	-2.7
Operational Empty Wt, lb	160 680	156 050	-2.9
Sea Level Static Thrust, lb	38 000	36 460	-4.1
Cruise Altitude, ft	39 000	39 000	0
L/D	19.8	19.8	0
SFC	0.54	0.53	-2.0
Range Factor, nmi	16 800	17 130	+2.0
Takeoff Field Length ft (SL, 84°F)	6 630	6 630	0
Approach Speed kn (Max Ldg Wt)	130	129	-0.8
Block Fuel per Passenger			
500 nmi, lb/Pass	47.6	46.3	-2.9
1000 nmi, lb/Pass	80.9	78.4	-3.0

5.9.3 IDEA CONFIGURATION ECONOMICS

The IDEA aircraft Direct Operating Cost (DOC) was developed and compared to that of the Baseline, using the ATA DOC formula with updated 1983 coefficients. The data summarized in table 36 shows a 2% advantage for the IDEA configuration, primarily attributable to the fuel burn difference.

Specific advantages derived from the systems improvements are difficult to establish clearly at the airplane level using the formula and sensitivity coefficient characteristic of the ATA DOC system. System level comparisons were examined in detail, using a cost/benefit analysis method which considers the total cost of aircraft ownership.

Table 36. Direct Operating Cost Comparison—Baseline vs IDEA

1983 U.S. Domestic Rules 500-nmi Range	Baseline	IDEA
Takeoff Gross Weight (lb)	268,040	260,980
Number of Passenger Seats	197	197
Block Fuel (lb)/(lb/Seat)	9,385/47.6	9,120/46.3
Depreciation, Airframe and Engine (\$M)	3.19	3.19
Insurance (\$M)	0.10	0.10
Flight Crew (\$M)	1.45	1.45
Fuel (@ \$1.50/gal) (\$M)	4.42	4.28
Airframe, Material and Burdened Labor (\$M)	0.87	0.85
Engine, Material and Burdened Labor (\$M)	0.68	0.65
DOC (\$M/yr)	10.70	10.50
(\$/Seat-Mile)	8.783	8.616
(Cents/Average Seat-Mile)	4.459	4.374

5.9.3.1 Cost/Benefit Analysis Methodology

The cost/benefit analysis methodology has been developed to provide a comprehensive comparison between two or more systems. The analysis provides an assessment of all cash flows which will be experienced by an airline as a result of acquiring, financing, operating and maintaining a system over the projected life of that equipment in revenue service. The predominant factors are the equipment investment cost, flight operations, and tax adjustment. A detailed list of all elements considered are outlined in figure 67.

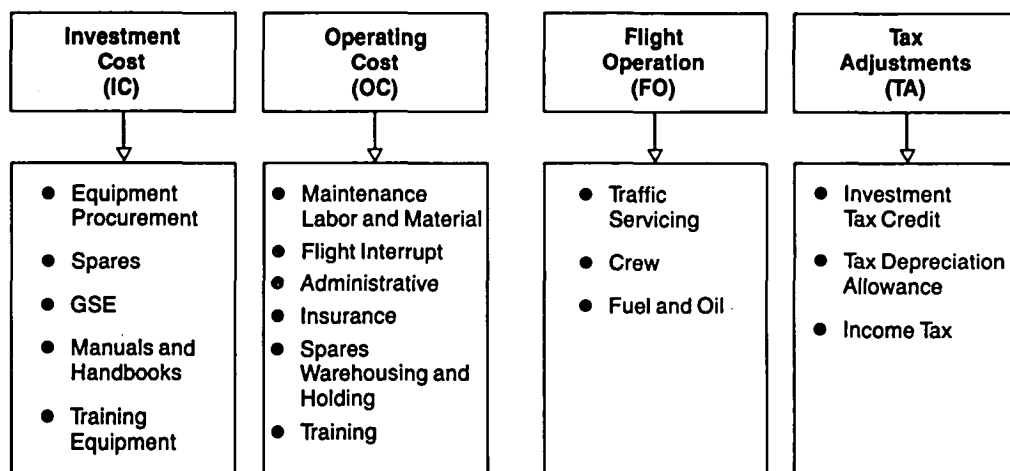

Figure 67. Cost/Benefit Analysis

For the majority of the baseline configuration data base, information on the 767 and 757 programs revised to 1983 dollars was used. For the IDEA airplane systems, equipment cost estimates were received from various vendors familiar with and interested in developing the technology for the 1990 time frame.

The following ground rules were used for the cost/benefit analysis:

- 1) Airline fleet of 30 airplanes operated for 15 years service.
- 2) Nonrecurring cost based on production of 300 airplanes.
- 3) Depreciation schedule of 10 years.
- 4) Investment tax credit at 10%.
- 5) Combined corporate and state income tax at 48%.
- 6) Annual inflation rate of 7% for material and labor.
- 7) Then current dollars, after taxes are assumed.
- 8) Standard spares level complement, treated as capitalized equipment.
- 9) Fuel price at \$1.50/U.S. gal.

The ground rules are based on typical conditions of the domestic airlines and the factors which have the most direct bearing on the economics that influence the cost of ownership. The depreciation schedule of ten years was based on airline analysis which simulates a profitable carrier. The 15-year service life is the design criteria used by the system designers.

5.9.3.2 Cost/Benefit Analysis

The cost/benefit analysis was separated into five separate packages to provide a readily accessible correlation of weights, equipment cost, maintenance costs, performance, and engineering responsibilities. These five are listed below in the order described in this report:

- 1) Flight controls and actuation
- 2) Electrical system
- 3) Data distribution
- 4) Avionics and flight deck
- 5) Environmental control system including ice protection

The cost benefit analysis summaries are listed in tables 37 through 41. The cost benefits for the five systems are summarized in table 42, which compares the IDEA-based systems to the baseline. Also included in the table are the expected savings when the fuel savings varies from the expected 3% to 2.4% and 3.6% (variance of $\pm 20\%$). This results in a change of approximately \$5M for the 30-airplane fleet over the 15-year service life. Equipment complexity is defined as the comparative level of maintenance required to service the system. This is based on the number of components, the projected propensity for required maintenance action, and the design of the system equipment. When available, previous service data on similar or identical equipment is used for determining the complexity comparison.

Table 37. Cost Benefit Analysis Summary—Flight Control and Actuation

	Baseline	IDEA
Shipset Equipment Cost	Base	~ Equal
Equipment Complexity	Base	0.9
Cost of Ownership Comparison for 30-Airplane Fleet for 15-Year Airplane Service	Base Cost	\$3.1M Reduced Cost

Table 38. Cost Benefit Analysis Summary—Electrical System

	Baseline	IDEA
Shipset Equipment Cost	*Base	3% More
Equipment Complexity	*Base	0.87
Cost of Ownership Comparison for 30-Airplane Fleet for 15-Year Airplane Service	*Base Cost	\$26.5M Reduced Cost

* Includes starting system and hydraulics

Table 39. Cost Benefit Analysis Summary—Data Distribution

	Baseline	IDEA
Shipset Equipment Cost	Base	~ 8% Less
Equipment Complexity	Base	1.0
Cost of Ownership Comparison for 30–Airplane Fleet for 15–Year Airplane Service	Base Cost	\$18.1M Reduced Cost

Table 40. Cost Benefit Analysis Summary—Avionics and Flight Deck

	Baseline	IDEA
Shipset Equipment Cost	Base	~ 8% Less
Equipment Complexity	Base	0.8
Cost of Ownership Comparison for 30–Airplane Fleet for 15–Year Airplane Service	Base Cost	\$7.8M Reduced Cost

Table 41. Cost Benefit Analysis Summary—Environmental Control System

	Baseline	IDEA
Shipset Equipment Cost	*Base	74% More
Equipment Complexity	*Base	1.25
Cost of Ownership Comparison for 30–Airplane Fleet for 15–Year Airplane Service	*Base Cost	\$13.4M Reduced Cost

* Includes ice protection

Table 42. Cost Benefit of Baseline Compared to IDEA

Airplane Configuration	Baseline	IDEA		
Fuel Savings	Base	@ 2.4%	@ 3.0%	@ 3.6%
System		Cost Savings in \$M 15-Year Service Service for 30-Airplane Fleet		
Flight Controls and Actuation	Base	2.6	3.1*	3.5
Electrical	Base	26.3	26.5*	26.7
Data Distribution	Base	17.9	18.1*	18.4
Avionics and Flight Deck	Base	7.6	7.8*	7.9
Environmental Control **	Base	9.4	13.4*	17.3
Projected Potential Cost Savings	Base	63.8	68.9*	73.8

* Tables 37 through 41

** Includes ice protection

The effects of fuel price change on the benefits derived from the IDEA systems were computed and are summarized in table 43. The basic fuel price used for this report was specified at \$1.50/gal. To develop the fuel sensitivity analysis, the fuel price was varied \pm \$0.25 to \$1.25 and \$1.75/gal. For this incremental change in fuel price, the cost of ownership was affected by approximately \$9.8M. For an increase of \$0.10/gal, a relative reduction for the five systems would be approximately \$3.9M for the 30-airplane fleet over the 15-year service life.

The rate of cost change is unique to each system and is not necessarily linear. Time and budget limitations prevented a detailed fuel cost sensitivity analysis. Additional economic analysis will be required to develop sensitivities for equipment cost, performance, weight, maintenance, and schedule reliability effects to optimize each system for the IDEA configuration.

Table 43. Benefit of IDEA Compared to Baseline
(Fuel Price @ \$1.25, \$1.50 and \$1.75/gal)

Fuel Price/gal	Cost of Ownership Reduction for 30-Airplane Fleet, 15-Year Service (\$M)		
	\$1.25	\$1.50	\$1.75
System		*	
Flight Controls and Actuation	2.9	3.1	3.3
Electrical	22.9	26.5	30.1
Data Distribution	15.1	18.1	21.1
Avionics and Flight Deck	7.6	7.8	7.9
Environmental Control	10.5	13.4	16.2
Projected Potential Cost Reduction	59.0	68.9	78.6

*Tables 37 through 41

6.0 ALTERNATE IDEA CONFIGURATION

The alternate IDEA configuration incorporates advanced technologies that would be available after a 1990 go-ahead. The two major advances are the use of composite material for primary structure, and counter-rotating turboprop propulsion systems. Configuration changes include aft-mounted engines and the use of a canard (fig. 68). Standard Boeing preliminary design methods were used to analyze the alternate IDEA configuration.

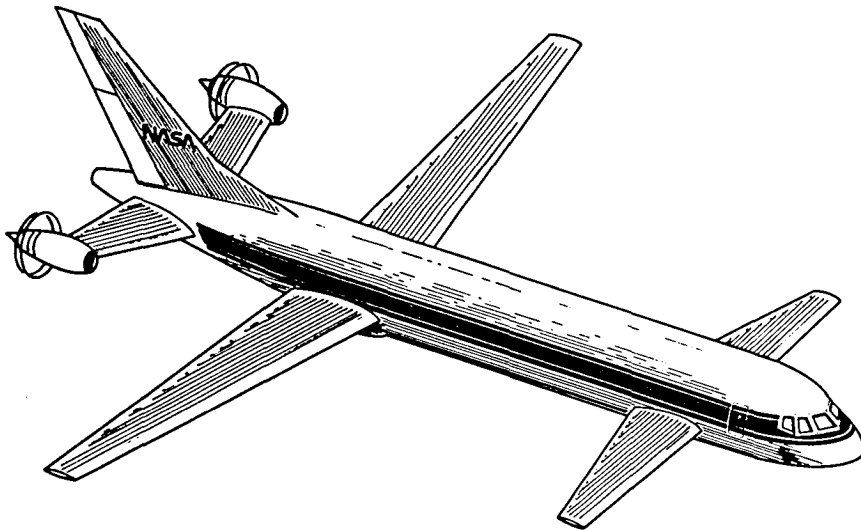

Figure 68. Alternate Configuration

6.1 AIRPLANE PERFORMANCE

The configuration and technology changes described above were incorporated into the Alternate IDEA configuration, and the airplane was resized to the same payload-range capability. A configuration performance comparison is shown in table 44. The major changes are the large reductions in takeoff and landing weights, engine size, cruise SFC and fuel burn per passenger, due primarily to the advanced turboprop propulsion system. Takeoff field length and landing approach speed capabilities are unchanged.

Table 44. IDEA and Alternate Configuration Performance Comparison

	IDEA-Based	Alternate	Increment, %
• Design Range = 4006 nmi			
• 197 Passengers			
• Cruise Mach = 0.8			
Max Brake Release Gross Wt, lb	260 980	236 000	-10
Operational Empty Wt, lb	156 050	146 500	- 6
Sea Level Static Thrust, lb	36 460	32 200	-12
Cruise Altitude, ft	39 000	39 000	0
L/D	19.8	19.4	- 2
SFC	0.53	0.43	-19
Range Factor, nmi	17 130	20 700	+21
Takeoff Field Length ft (SL, 84°F)	6 630	6 630	0
Approach Speed kn (Max Ldg Wt)	129	129	0
Block Fuel per Passenger			
500 nmi, lb/Pass	46.3	35.1	-24
1000 nmi, lb/Pass	78.4	59.6	-24

6.2 ICE PROTECTION

The Alternate IDEA Configuration has some unique characteristics that present areas for future study. These areas are propeller ice protection, propeller damage from ice particles, canard ice protection, ice protection for the wing area in front of engine/propeller, and engine strut ice protection. These areas present subjects for study in addition to the present IDEA study (fig. 69).

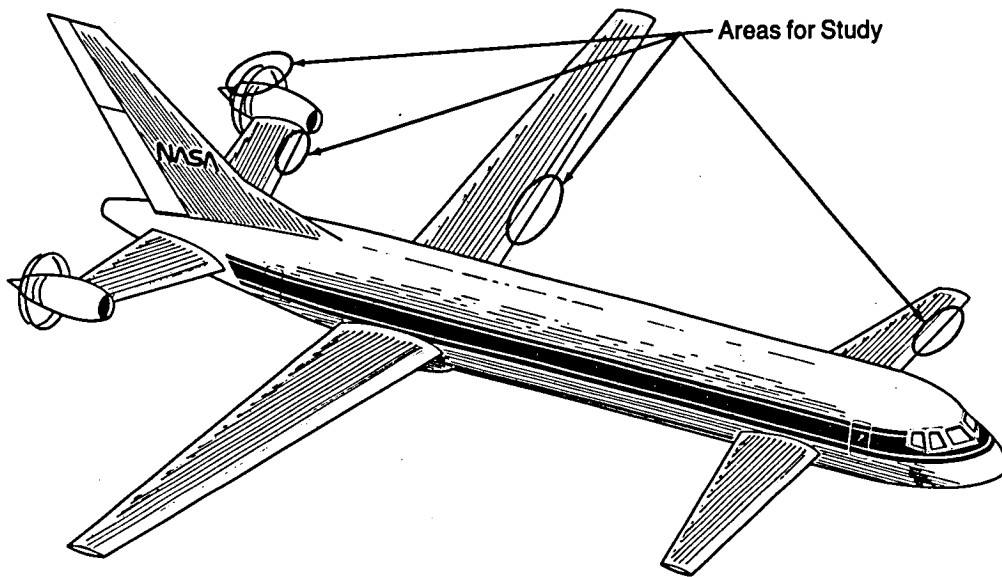
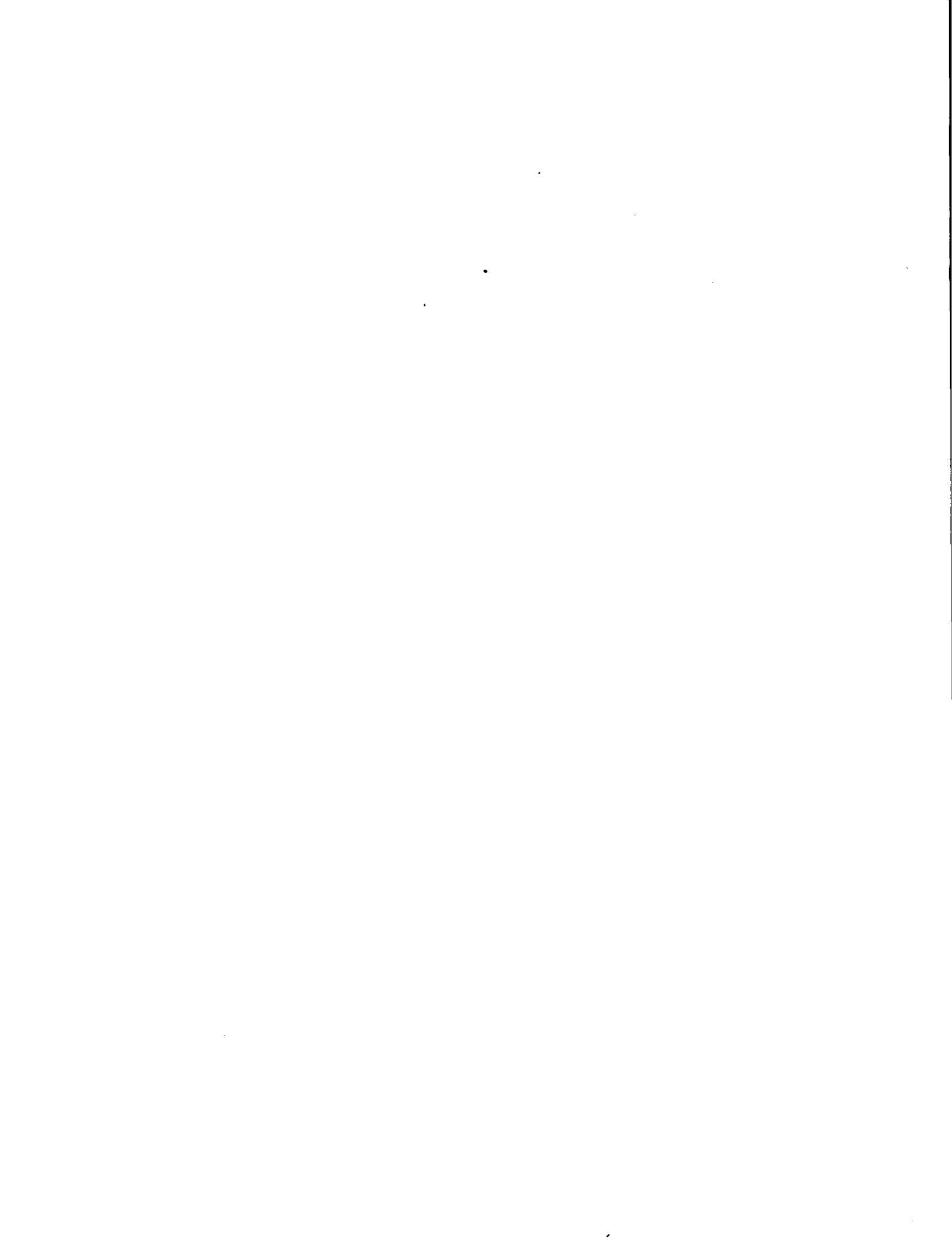

Figure 69. Alternate Configuration Areas of Study



6.3 ALTERNATE AND IDEA DOC COMPARISON

The Alternate IDEA configuration I was compared to the IDEA configuration for determination of differences in DOC. This particular alternate was configured with counter-rotating propfans located off the aft fuselage. The primary advantage for this aircraft was the reduced fuel burn of 24% over the IDEA turbofan equipment. The resulting DOC was 6.9% less than the IDEA airplane DOC, and included some offsets in the depreciation and maintenance costs. Table 45 provides a comparison between the two configurations.

Table 45. Direct Operating Cost Comparison —IDEA vs Alternate IDEA Configuration

- 1983 U.S. Domestic Rules
- 500-nmi Range

	IDEA-Based	Alternate Configuration
Takeoff Gross Weight (lb)	260,980	236,000
Number of Passenger Seats	197	197
Block Fuel (lb)/(lb/Seat)	9,120/46.2	6,915/35.1
Depreciation, Airframe Engine	3.19	3.39
Insurance	0.10	0.10
Flight Crew	1.43	1.41
Fuel (at \$1.50/gal)	4.48	3.34
Airframe, Material and Burdened Labor	0.85	0.82
Engine Material Burdened Labor	0.65	0.81
DOC (Max Pass), \$M/Yr	10.50	9.87
(\$/Seat-Mile)	8.616	8.097
(Cents/Average Seat-Mile)	4.374	4.110

THE UNIVERSITY OF CHICAGO

THE UNIVERSITY OF CHICAGO

THE UNIVERSITY OF CHICAGO

THE UNIVERSITY OF CHICAGO

THE UNIVERSITY OF CHICAGO

THE UNIVERSITY OF CHICAGO

THE UNIVERSITY OF CHICAGO

THE UNIVERSITY OF CHICAGO

THE UNIVERSITY OF CHICAGO

THE UNIVERSITY OF CHICAGO

THE UNIVERSITY OF CHICAGO

THE UNIVERSITY OF CHICAGO

THE UNIVERSITY OF CHICAGO

THE UNIVERSITY OF CHICAGO

THE UNIVERSITY OF CHICAGO

THE UNIVERSITY OF CHICAGO

THE UNIVERSITY OF CHICAGO

THE UNIVERSITY OF CHICAGO

7.0 CONFIGURATION COMPARISONS

7.1 AIRPLANE PERFORMANCE

A configuration performance summary for all three configurations is shown in table 46. Block fuel and block time as a function of range is given in figure 70. Fuel efficiency (passenger nmi/lb fuel) as a function of range is given in figure 71. Takeoff field length and range as a function of takeoff weight is given in figure 72.

Table 46. Performance Comparison Summary

- Design Range = 4006 nmi
- 197 Passengers
- Cruise Mach = 0.80

	Baseline	IDEA-Based	Alternate
Max Brake Release Gross Wt, lb	268,040	260,980	236,000
Operational Empty Wt, lb	160,680	156,050	146,500
Sea Level Static Thrust, lb	38,000	36,460	32,200
Cruise Altitude, ft	39,000	39,000	39,000
• L/D	19.8	19.8	19.4
• SFC	0.54	0.53	0.43
• Range Factor, nmi	16,800	17,130	20,700
Takeoff Field Length, ft (SL, 84°F)	6,630	6,630	6,630
Approach Speed, kn (Max Ldg Wt)	130	129	129
Block Fuel per Passenger			
• 500 nmi, lb/Pass	47.6	46.3	35.1
• 1000 nmi, lb/Pass	80.9	78.4	59.6

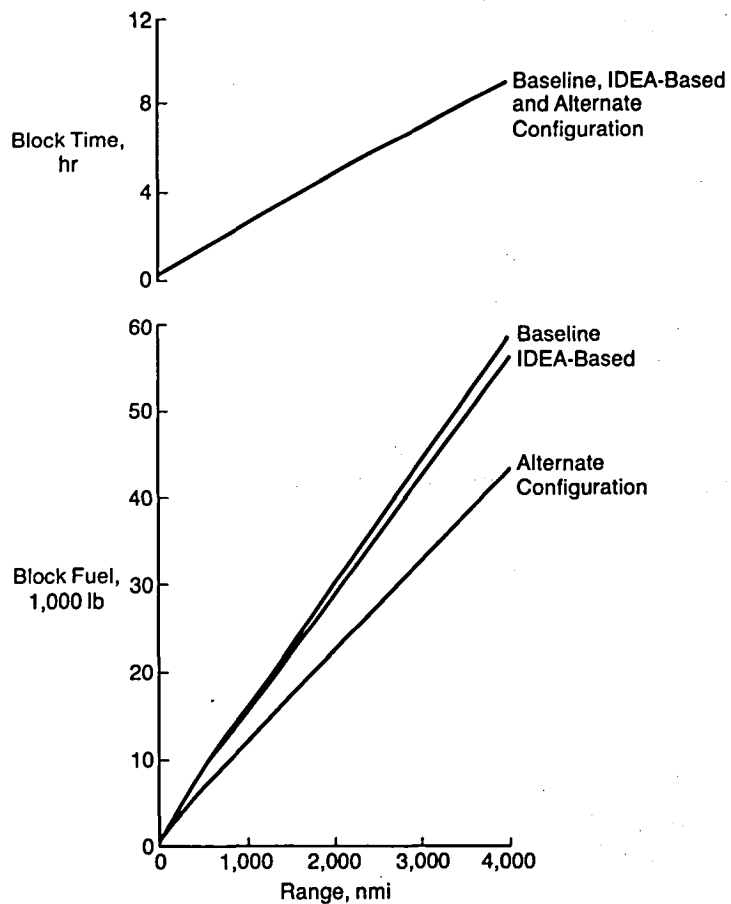

Figure 70. Block Fuel, Block Time Comparison

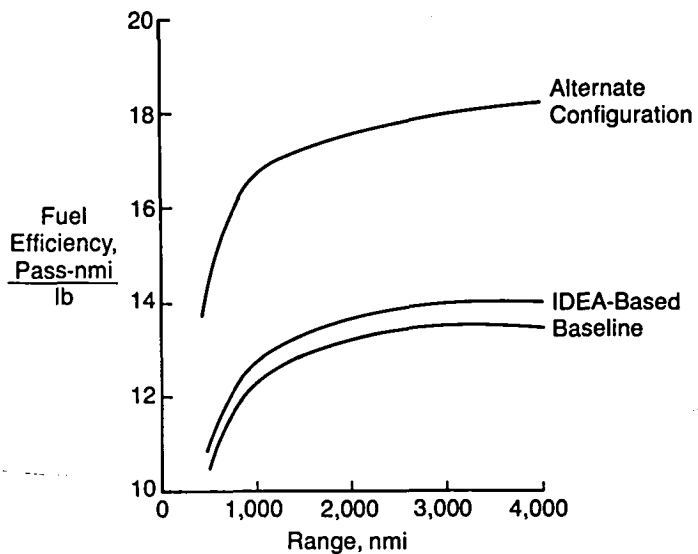

Figure 71. Fuel Efficiency Comparison

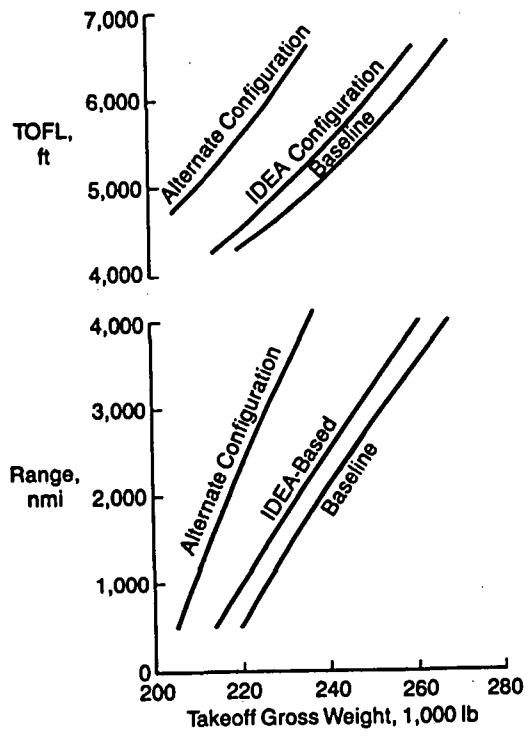

Figure 72. Takeoff Field Length and Range Comparison

8.0 RESEARCH RECOMMENDATIONS

The research recommendations for each of the major technical areas are presented under two broad categories: IDEA Research Tasks and Other Research Tasks. The IDEA Research Tasks comprise the research and development necessary for reaching the technical capability which was assumed to exist for the system elements of the IDEA configuration. The type of research varies considerably from item to item. Some elements need almost the whole development sequence, from a present conceptual status through analysis, design, test, and demonstration, while others need only performance verification or the development of application guidelines and experience.

The Other Research Tasks are brief lists of related developments which, although they were not included in the IDEA configuration, are of sufficient interest to be considered for inclusion in broader research programs. Some of the categories of Other Research Tasks are:

- 1) Features outside the specified scope of the IDEA study.
- 2) Alternative approaches which were almost as attractive as those selected.
- 3) Developments considered longer term than the IDEA time scale.
- 4) Capabilities which would be made more feasible by successful development of IDEA technology.
- 5) Ventures for which feasibility has not yet been demonstrated, but which merit periodic review as technology progresses.

For each major technical area, the overall objective of research is discussed, followed by a discussion of the research needed to meet the particular objective. The areas in which NASA internal and funded research is appropriate are then listed.

8.1 RESEARCH SUMMARY

The recommended NASA research activity is shown in table 47. The most important aspects for each system are listed below.

Digital/Electric Flight–Critical Flight Control

- Generic Fault Protection
- Distributed Processing

Electric Actuation

- Actuator Development
- Controller Development

Secondary Power System

- Distribution System
- Flight–Critical Power Sources

Digital Data Distribution

- Hardware
- Systems

Digital Avionics System Architecture

- Architecture Evaluation/Synthesis Tools
- High Mean Time–Between–Failures (MTBF) Remote Electronics

Advanced Flight Deck

- Controls Evaluation

Electric ECS

- Efficiency and Weight Improvement

Electric Ice Protection

- Electro–Impulse De–icing

Table 47. Recommended NASA Research Activity

	Committee Participation	Analysis	Trade Study	Simulation	Development	Test	Flight Test	Cost
Digital/Electric Flight-Critical Flight Control								
Generic Fault Protection		X		X	X	X		1M
In-Line Monitoring		X						300K
Software Cost Reduction			X					1M
Distributed Processing		X			X	X		1M
Electric Actuation								
Actuator Development		X		X	X	X	X	3M
Controller Development					X	X		1M
Redundancy					X	X		300K
Secondary Power System								
Power Conversion					X	X		1M
Distribution System		X		X	X	X		3M
Distribution Voltage			X					300K
Flight-Critical Power Sources					X		X	3M
Power Conditioning		X		X				1M
Motors and Generators		X			X			300K
Digital Data Distribution								
Hardware					X	X	X	1M
Systems		X		X				1M
Digital Avionics System Architecture								
Architecture Evaluation/Synthesis Tools					X			1M
Software Standards and Methods	X							--
High-MTBF Remote Electronics					X	X	X	3M
Mechanical System Avionics			X					300K
Standard Sensors and Actuators			X					300K
Power Conditioning and Conversion		X						300K
Advanced Flight Deck								
Controls Evaluation				X			X	1M
Shallow, Self-Contained Displays							X	300K
Electric ECS								
Efficiency and Weight Improvement						X		300K
Electric Ice Protection								
Electro-Impulse De-Icing		X				X	X	1M
Ice Thickness Measurement							X	300K
Engine Ice Ingestion						X		1M

8.2 DIGITAL/ELECTRIC FLIGHT-CRITICAL FLIGHT CONTROL

As shown in figure 73, the IDEA flight control system must be capable of providing verifiably safe flight-critical operation with electrically-powered control surface actuation and extensive use of digital computation and signaling. The system must operate correctly throughout the service life of the airplane, assuming reasonable maintenance methods and skill levels are maintained, and must function in spite of occasional lightning strikes, electrical system faults, component failures, and engine failures. In addition, the process of specification, design, and test of both hardware and software must not introduce subtle departures from the system requirements which could cause system malfunction in some unlikely but possible set of operating conditions.

Objective: Develop and demonstrate

- Design methodology
- Key technical elements

of a digital/electric flight control system for flight-critical applications

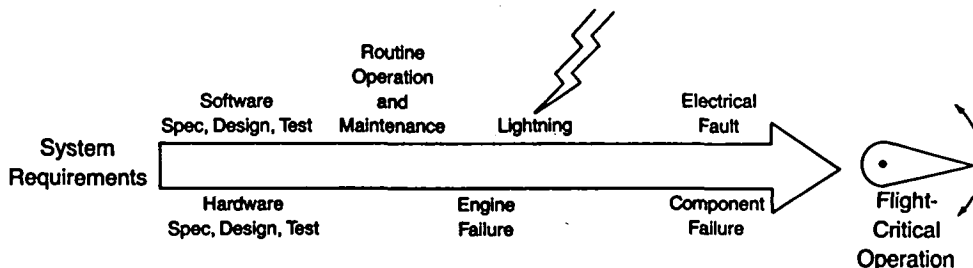

Figure 73. Digital/Electric Flight—Critical Flight Control Research Objective

8.2.1 IDEA RESEARCH TASKS

8.2.1.1 Generic Fault Protection

Random failure of components can be accommodated to any required probability of system failure by replication of system elements, with appropriate redundancy management schemes. This leaves the problem of generic failures, in which identical failure modes affect all of a redundant set of elements simultaneously. The two broad approaches to this problem are termed generic fault avoidance and generic fault tolerance.

In the fault avoidance approach, the flight critical function is reduced to the simplest practical form and isolated from less critical computations. This function is then implemented with a combination of hardware, firmware, and software which minimizes the number of possible internal states and operational sequences. Verification then consists of analyses and tests which subject the system to a range of conditions which exercise all possible computational conditions and paths. The successful development of an economical form of this approach would lead to appreciable savings in hardware and software costs for flight-critical systems.

In the fault tolerance approach, it is assumed that generic faults cannot economically be proven to be absent, and the system is configured to tolerate their presence, usually by replicating functions with dissimilar hardware and software. This is the approach being pursued most energetically by industry, and will probably be used in any near-term flight critical systems.

Research is needed in the development of fault protection techniques and the assessment of their practicality and relative cost.

8.2.1.2 In-Line Monitoring

The extensive replication of hardware elements required to meet the system reliability requirements of flight-critical systems leads to an increase in hardware weight, cost, and volume, as well as more complex system architecture. Self-monitoring can decrease the number of replicated elements or their required reliability as a function of the percentage of coverage achieved. A systematic analysis of methods of achieving and verifying high in-line monitoring coverage at minimum cost for the whole range of flight control elements is needed.

8.2.1.3 Software Cost Reduction

Software design and test have become major costs, especially in systems with dissimilar redundant software. Standardization is one route to more efficient software production. If studies show that industry-wide adoption of a standard higher order language and instruction set (such as Ada and ISA 1750) is economically advantageous, then standards should be selected, the extent and limits of standardization defined, and tools and experience for their use developed. A library of standard software modules for common functions would reduce coding and test costs substantially, as well as decrease the probability of software errors. The use of such standards in NASA in-house and funded programs would be helpful.

8.2.1.4 Distributed Processing

The use of local computation associated with actuators and sensors can reduce the data communication and central processing loads and, in some cases, enhance system reliability. Research is needed both in architectural system details and in the implementation of distributed processing elements. Cost data must be developed for use in architectural trade studies.

8.2.2 OTHER RESEARCH TASKS

8.2.2.1 Optical Technology

In addition to the basic fiber-optic data transmission development, which is an integral part of data distribution research, there are many possible applications of optical devices in sensing, actuation signaling, electrical isolation, power transmission, and computation. Required activities include innovative development, testing, and system application analysis.

8.2.2.2 Active Control Modes

The development of the flexible, reliable, economical digital architectures and electric actuation devices postulated for the IDEA configuration may make additional active control modes more economical. Economic trade studies of non-IDEA modes, such as flutter mode control and vertical tail size reduction, should be re-examined.

8.2.3 RECOMMENDED NASA ACTIVITY

Generic Fault Protection	\$1M	Analysis Simulation Development Test
In-Line Monitoring	\$300K	Analysis
Software Test Reduction	\$1M	Trade Study
Distributed Processing	\$1M	Analysis Development Test

8.3 ELECTRIC ACTUATION

As indicated in figure 74, the IDEA designers need the kind of options and information relative to electric actuators that now exist for hydraulic actuators. Options include a range of actuators, controllers, and linkage and disconnect mechanisms. This hardware must cover the broad range of capacity and other characteristics required for all actuation requirements on the airplane, with as much commonality as is practical. Required information includes detailed characteristics and design and selection guidelines.

Objective: Develop a family of

- Electric actuators
- Associated hardware
- Design guidelines

that economically meet all airplane actuation requirements

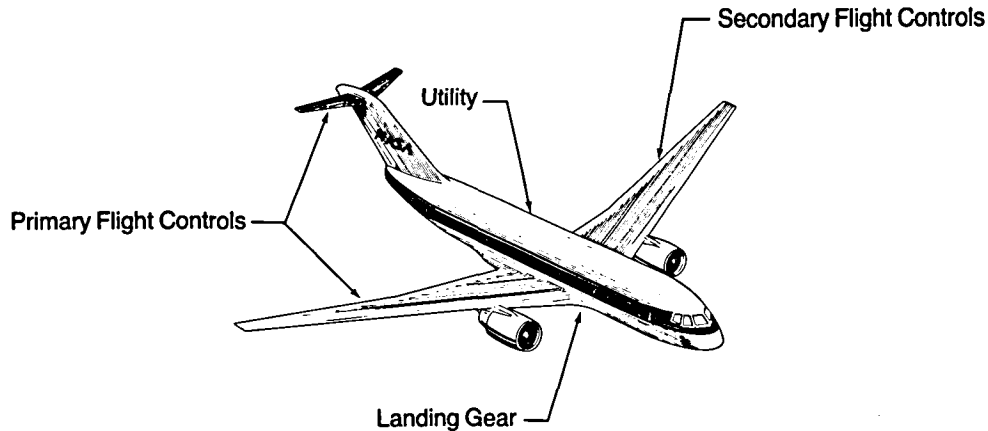

Figure 74. Electric Actuation Research Objective

8.3.1 IDEA RESEARCH TASKS

8.3.1.1 Actuator Development

Electric actuators are different enough from hydraulic actuators that all aspects of their design, particularly the trades among their various performance parameters, must be studied from the viewpoint of the basic physics of their operation. Areas to be studied include:

Motor Geometry – The relationship between such things as motor construction and dimensions and torque, torque/inertia ratio, and thermal characteristics.

Torque-Speed Conversion – The relative cost, weight, efficiency and reliability of existing and innovative new mechanical and hydraulic speed reducers for a range of speed ratios and torque levels.

Actuator Tailoring – Matching of combinations of actuator characteristics to the combinations of required force, rate, duty cycle, bandwidth, and physical envelope.

Actuator/Load Connection – Linkages, gain changers, disconnects, brakes.

8.3.1.2 Controller Development

Basic Control – The best switch configuration and control logic for operating the motor through regimes of acceleration, translation, force holding, and regeneration.

Intelligence – Loop closure, status assessment, calibration, redundancy management.

Reliability/Environment – Basic design, component selection and mechanical/thermal design to yield a high MTBF in harsh environments.

8.3.1.3 Redundancy

Logic – Monitoring, selection and control of redundant elements.

Mechanical Design – Mechanical interconnection of redundant components for reliability enhancement.

8.3.2 OTHER RESEARCH TASKS

8.3.2.1 Local Energy Storage

Hinge-Moment Balancing – Actuator size and weight can be drastically reduced if hydraulic or other countermoment-producing elements are combined with the actuator.

Regeneration Energy – Local short-term storage of the energy returned to the system by returning control surfaces and deceleration of high-speed motors may simplify the power distribution system.

8.3.3.2 Heat Rejection to Composite Structure

Means of dissipating waste heat from large actuators without high-thermal-conductivity metal structure may be required for aircraft with extensive composite material use.

8.3.3.3 Super-Conducting Motors

If motors with windings maintained at super-conducting temperatures could be made practical, appreciable decreases in electric energy losses would result.

8.3.3.4 Electromagnetic Braking

Replacement of friction brakes with high-power, low-duty-cycle generators with remote energy dissipation could reduce brake and tire maintenance costs.

8.3.3 RECOMMENDED NASA ACTIVITY

Actuator Development	\$3M	Analysis Simulation Development Test Flight Test
Controller Development	\$1M	Development Test
Redundancy	\$300K	Development Test



8.4 ELECTRIC SECONDARY POWER SYSTEM

Figure 75 illustrates the most salient features of an electric-only system which could adequately replace the present day multimode secondary power systems. The prerequisite for accomplishing this is the development, test, and demonstration of all the elements of the high-power main power sources, the dissimilar redundant critical power sources, and the distribution and conversion system. The complete system must provide both high power to utility loads and well-conditioned, always-available power to flight-critical loads.

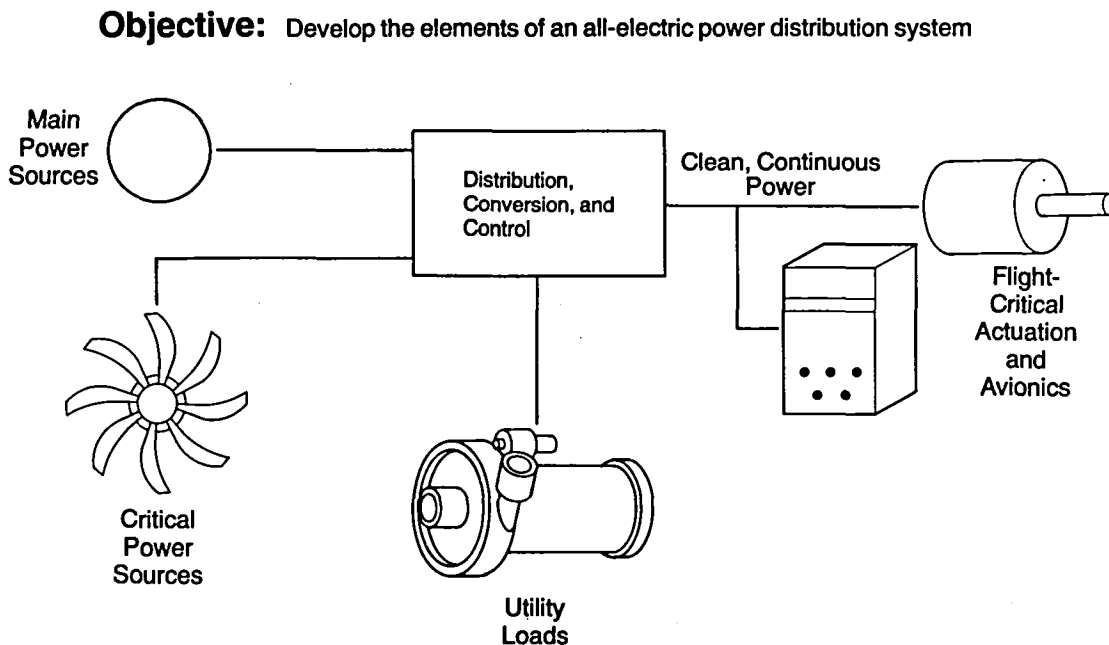

Figure 75. Electric Secondary Power System Research Objective

8.4.1 IDEA RESEARCH TASKS

8.4.1.1 Power Conversion

Advanced electric systems rely heavily on electronic conversion and regulation. Development of components and converter architectures to achieve low losses and high reliability at high power levels is required.

8.4.1.2 Distribution System

The IDEA electric distribution system is based on a sophisticated sensing, communication, and control logic system for fault protection and load management. The sensing and control devices and the system control logic and architecture must be developed.

8.4.1.3 Distribution Voltage

Coordinated, parallel studies of high-frequency AC, high-voltage DC, and variable-voltage/variable-frequency, mid-frequency power distribution are necessary to determine the applications for which each is advantageous and the best choice or combination for specific airplanes.

8.4.1.4 Flight-Critical Power Sources

The safety and certification of an airplane with a flight-critical control system depend on a set of power sources sufficiently redundant and dissimilar that all power would be lost only after a combination of several unrelated, unlikely events. Dissimilar power sources, particularly those not dependent on normal engine operation, or on the engines at all, are necessary. In the IDEA configuration, one of the sources which will continue to be available after most types of engine failure is the section of the turbine connected to the fan. Better information is needed on the matching of fan-driven generators to the fan speed characteristics, as well as innovative ways of connecting the generator to the fan. Integral generators, such as coils surrounding the fan that are excited by magnets on the fan blades, should be investigated. Other full-time power sources, such as other ram-air-driven devices or wingtip-vortex-driven generators, should be investigated.

8.4.1.5 Power Conditioning

Avionics/Actuator/Conditioner Trades – The architecture and design philosophy for the critical power bus in the IDEA electrical system provides an excellent framework for the specification of power-quality-related characteristics of the load and source units. The detailed trades between the requirements imposed on the avionics-unit power supplies, the actuator controllers, and the power conditioners must be developed. Alternative concepts with distributed power conditioning residing in the user equipment should also be considered.

Capacity/Demand Management – The capacity, and hence the weight and cost, of the power conditioners is set by a high combined demand from the actuators. It may be possible to appreciably decrease this peak demand by some limiting or delaying of individual demands during short peak demand periods. This must be done through coordinated control from a central point, such as the power conditioner or flight control computers, without introducing undesirable cross-channel failure modes.

8.4.1.6 Motors and Generators

Utility Motors – Redesign of motors to match characteristics of selected power distribution systems.

Starter/Generator – Optimization of the combination of the engine starting torque sequence and the starter/generator design.

8.4.2 OTHER RESEARCH TASKS

8.4.2.1 Novel Power Sources

Other dissimilar sources of electrical power, such as engine/exhaust heat, could be explored.

8.4.2.2 Energy Storage

The required capacity at various levels within the electric system can be reduced with short-term energy storage to service short-duration load peaks. Advanced energy storage devices, such as flywheels, might prove economical.

8.4.3 RECOMMENDED NASA ACTIVITY

Power Conversion	\$1M	Development Test
Distribution System	\$3M	Analysis Simulation Development Test
Distribution Voltage	\$300K	Trade Study
Flight-Critical Power Sources	\$3M	Development Flight Test
Power Conditioning	\$1M	Analysis Simulation
Motors and Generators	\$300K	Analysis Development

Objective: Develop

- Hardware elements
- Design methodology

for an economical, highly reliable data bus system

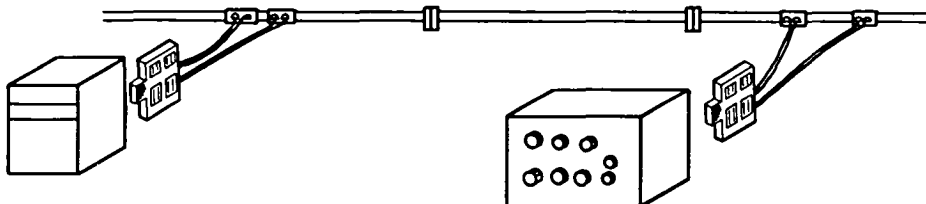

Figure 76. Digital Data Distribution Research Objective

8.5 DIGITAL DATA DISTRIBUTION

Data buses of the general type assumed for the IDEA configuration are now in the prototype stage. As shown in figure 77, required research falls into the two categories of further development and test of various hardware elements and development of data bus system level design methodology.

8.5.1 IDEA RESEARCH TASKS

8.5.1.1 Hardware

Remote Electronics Reliability – Widespread application of data buses is absolutely dependent on terminal hardware that can be installed in any required location on an airplane without experiencing undue failure rates. Designs are required which combine rugged components, good mechanical design, and good thermal design (considering both passive and active local heat dissipation).

Transmission Media and Couplers – Mechanical and electrical design of wire and fiber-optic cables and couplers must be an economical compromise among weight, cost, EMI immunity, reliability, and installation cost.

Large Fiber-Optic Systems – Methods of increasing the number of terminals that can be connected to a single bus without creating too wide a range of signal power levels due to coupler attenuation.

Fiber-Optic Sensors – Continued development of sensors which require no electrical connections for either power or signaling is desirable.

8.5.1.2 Systems

Staleness/Timing Tolerance – In a complex avionics system, signals arriving from diverse sources are delayed by varying amounts. Systems must be designed to tolerate this.

Data Transfer Protocols – Protocol variations are needed which handle signals of mixed character on single buses and the transfer of data between multiple buses without excessive complexity or overhead.

Fault Tolerance – Trade studies are needed to determine the best combination of redundant buses and internal bus design to tolerate component failures.

Performance Validation – System simulation/emulation/stimulation is required to validate the performance of complex data distribution networks.

8.5.2 OTHER RESEARCH TASKS

8.5.2.1 Non-time Multiplexing

The problems caused by data delays may be solved in some limited applications through the replacement of time-division multiplexing by some form, or equivalent, of frequency-division multiplexing.

8.5.3 RECOMMENDED NASA ACTIVITY

Hardware	\$1M	Development Test Flight Test
Systems	\$1M	Analysis Simulation

8.6 DIGITAL AVIONICS SYSTEM ARCHITECTURE

As indicated in figure 77, in future airplanes there will be more interconnection and information exchange between the traditional avionics LRUs in the temperature controlled avionics bay and flight deck, remotely located avionics, and the avionics portions of mechanical and electrical systems. For such a system to work well and be economical to design, it is necessary to develop a range of analytical and simulation tools and design guidelines.

8.6.1 IDEA RESEARCH TASKS

8.6.1.1 Architecture Evaluation/Synthesis Tools

Simulations and models are needed to compare alternative architectures and to assist in preparing detailed subsystem requirements.

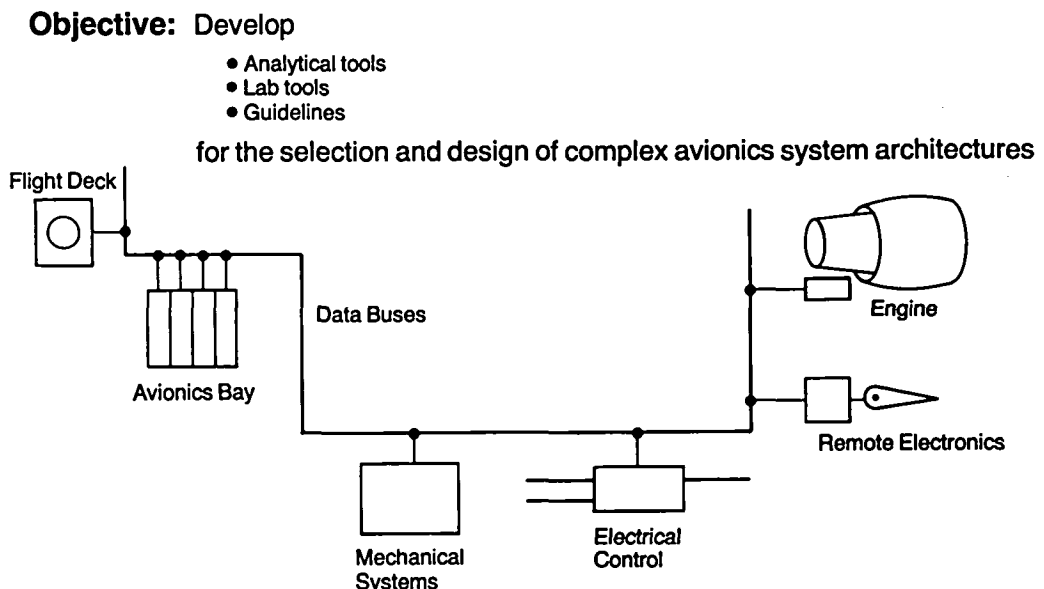

Figure 77. Digital Avionics System Architecture Research Objective

8.6.1.2 Software Standards and Methods

A highly structured, top-down software specification and design methodology is necessary.

8.6.1.3 High-MTBF Remote Electronics

As in the flight control system proper and the data bus terminals, there is a need in all airplane systems for electronic components, packaging concepts, and independent thermal protection which yield high enough reliability to assure required functional reliability and very low maintenance cost.

8.6.1.4 Mechanical System Avionics

With the widespread use of computers to improve the operation of mechanical systems, there has been a proliferation of microprocessors and interface hardware types. A determination should be made of the extent to which standardization in this area is economically desirable.

8.6.1.5 Standard Sensors and Actuators

As separate subsystems are integrated and their data are pooled and exchanged via common data buses, some standardization of sensors and actuators would reduce the procurement and logistics costs of the devices themselves and of interfacing them with the data buses.

8.6.1.6 Power Conditioning and Conversion

Avionics power supplies and power anomaly protection should be reoptimized to match the power conditioning philosophy of the IDEA configuration.

8.6.2 OTHER RESEARCH TASKS

8.6.2.1 Avionics Bay Redesign

With the removal from the avionics bay of hardware associated with sensors, displays, actuators, and other devices, and the increased physical integration of the major avionics subsystems remaining, the volume of avionics in the avionics bay may become small enough that it would be possible to eliminate the space for personnel access into the bay by restructuring the physical arrangement of avionics and providing external access.

8.6.3 RECOMMENDED NASA ACTIVITIES

Architecture Evaluation/Synthesis Tools	\$1M	Development
Software Standards and Methods	-	Committee Participation
High-MTBF Remote Electronics	\$3M	Development Test Flight Test
Mechanical System Avionics	\$300K	Trade Study
Standard Sensors and Actuators	\$300K	Trade Study
Power Conditioning and Conversion	\$300K	Analysis

8.7 ADVANCED FLIGHT DECK

The general objective in this area is illustrated in figure 78. From the broad field of flight deck hardware and procedures research, this section discusses the research specifically required for the IDEA configuration innovations, plus a small sample of other activities.

Objective: Develop flight deck elements for maximizing safe operation while improving airplane performance factors.

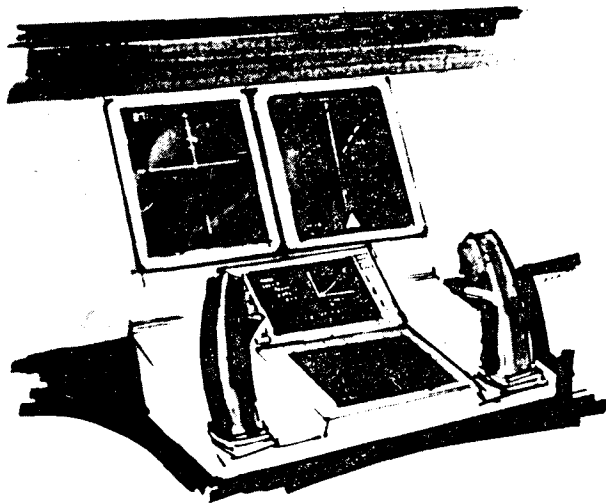

Figure 78. Advanced Flight Deck Research Objective

8.7.1 IDEA RESEARCH TASKS

8.7.1.1 Controls Evaluation

The static simulation study on which the IDEA flight deck controls selection was based must be validated and extended by dynamic simulation and flight test. Details to be resolved include the selection of functions which back-drive the controls, optimization of control deflection and force characteristics (feel), and selection of the form of control surface position indication.

8.7.1.2 Shallow, Self-Contained Displays

Flat-panel displays will easily accommodate the advanced compact display processing hardware.

8.7.2 OTHER RESEARCH TASKS

8.7.2.1 Takeoff and Landing Monitor

The decision-making tasks of the crew during takeoff and landing can be facilitated by a monitor showing performance margins in graphic form. The key technical areas are accurate measurement of airplane state and estimation of runway conditions.

8.7.2.2 Flight Deck Geometry

Short-throw controls and shallow displays may allow reshaping of the flight deck for better crew performance or reduced airplane length, weight, or drag.

8.7.2.3 Window Elimination

Indirect optical or TV techniques may allow eventual elimination or reduction in size of flight deck windows.

8.7.3 RECOMMENDED NASA ACTIVITY

Controls Evaluation	\$1M	Simulation Flight Test
Shallow, Self-Contained Displays	\$300K	Flight Test

8.8 ELECTRIC ECS

The general size and power requirements of the ECS are set by passenger comfort standards and thermodynamic limitations. However, as indicated in figure 79, continual small improvements in component efficiency and weight are possible.

Objective: Develop efficient, light-weight ECS equipment

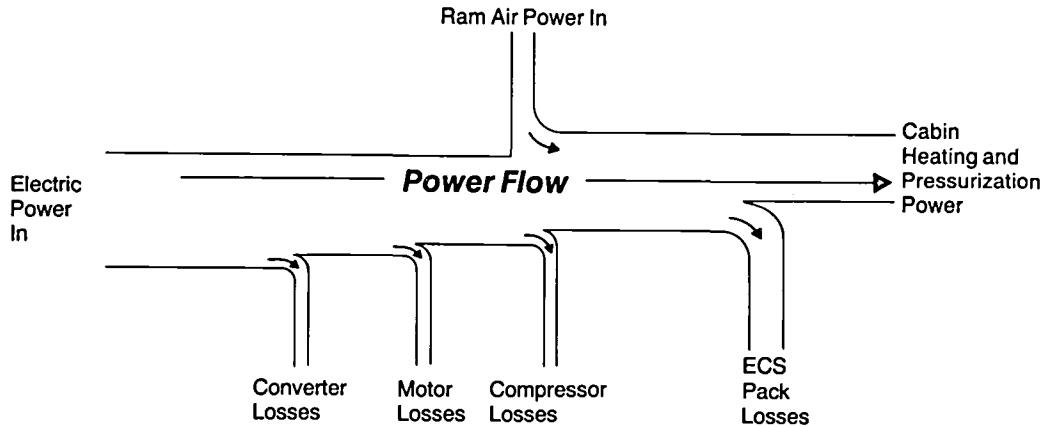

Figure 79. Electric ECS Research Objective

8.8.1 IDEA RESEARCH TASKS

8.8.1.1 Efficiency and Weight Improvement

Power losses and weight can be progressively reduced by design refinements in the compressors, drive motors, and motor controllers, and by innovative use of more sophisticated system control.

8.8.2 OTHER RESEARCH TASKS

8.8.2.1 Reduced Air Flow

There is a possible trade between the extra cost of reducing airplane air leakage and additional air filtering, and the reduced power and weight required for the lower air flow.

8.8.3 RECOMMENDED NASA ACTIVITY

Efficiency and Weight Improvement	\$300K	Test
-----------------------------------	--------	------

8.9 ELECTRIC ICE PROTECTION

As indicated in figure 80, the electromagnetic ice protection system selected for the IDEA-based configuration must be brought to a mature state.

Objective: Develop lightweight, efficient ice protection systems

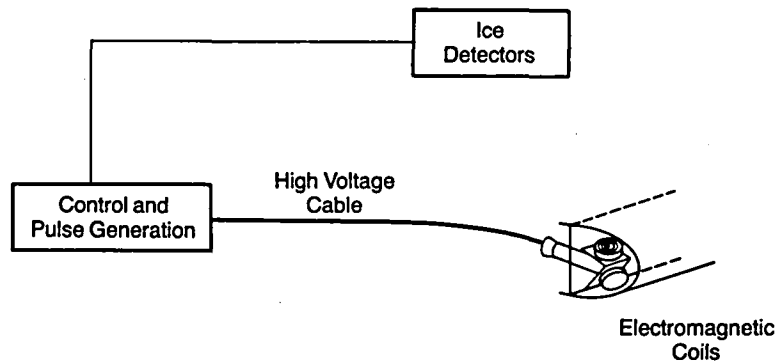

Figure 80. Electric Ice Protection Research Objective

8.9.1 IDEA RESEARCH TASKS

8.9.1.1 Electro-Impulse De-icing

Performance Prediction Methods – A data base must be developed, by test and analysis, which will allow ready design of the most economical system for each specific application.

High-Voltage Cables – Minimum weight cables are needed for transmitting the short-duration, high-power electrical pulses to the coils.

Acoustic Noise Control – Ice protection system design and structural design for adequate limiting of cabin noise due to system operation should be developed.

8.9.1.2 Ice Thickness Measurement

It is necessary to develop and test the ice-thickness sensors that are used for initiation and timing of system operation. These sensors should be nonobtrusive devices located on the protected surface.

8.9.1.3 Engine Ice Ingestion

Engine tests are needed to determine the long-term effects, if any, of ingestion of the small particles of ice from the cowl.

8.9.2 OTHER RESEARCH TASKS

8.9.2.1 Ice-Phobic Coating

Continuing experiments with coatings to which ice has low adhesion, but which can withstand operational erosion, should be monitored.

8.9.3 RECOMMENDED NASA ACTIVITY

Electro-Impulse De-icing	\$1M	Analysis Test Flight Test
Ice Thickness Measurement	\$300K	Flight Test
Engine Ice Ingestion	\$1M	Test

9.0 CONCLUDING REMARKS

The major objectives of the IDEA program were to define and evaluate an IDEA configuration, and to identify the research and development required for potential application to transport aircraft in the early 1990s.

Although this study was of short duration considering the scope of the investigation, it produced results which indicate considerable potential in the proposed IDEA Airplane. The study results point out the necessity for the immediate organization of a comprehensive program of research and development if the goal of a 1990 airplane program go-ahead is to be met. The study also suggests some areas of systems research that should be examined for maximum benefit to be gained from parallel development, whether the original goals of the IDEA program are to be pursued or not.

In summary, the study indicated the following rationale for prompt initiation of the IDEA program recommendations as well as for overall direction and sponsorship by a single source:

- The overall program objectives are timely and relevant. They seek to achieve improved efficiency and performance of technologies for future transport aircraft while reducing costs of acquisition and operation.
- The inclusion of diverse technologies into one study program is mandatory for proper understanding of system relationships during the definition and accomplishment of the significant research and development requirements. In this manner, the program can ensure the maximum achievable airplane performance and economic benefits.
- The advancement of digital/electric system technologies requires a unified approach to provide the necessary forum for overall evaluation and integration of research and development. Such guidance will also provide direction for future parallel and complementary development.

- The recommended research and development activities must be performed in a systematic manner, utilizing the general approaches suggested by the IDEA study.
- The research and development activities require a high level of commitment in order to realize an attendant high degree of success.

In this manner the achievement of the potential performance and economic benefits indicated can be realized and applied to future transport aircraft. The IDEA configuration represents a positive step toward the many operational benefits of a fully integrated system. In addition, digital/electric systems offer a positive approach to cost reduction as well as increased functional capability. The application of these new concepts will result in reducing many of the system's DOC component values and will reverse the trend of increasingly expensive airplane systems. Anticipating the successful completion of the appropriate research and development, it is expected that many of the potential benefits indicated can be realized in time for application to commercial transports of the 1990s.

10.0 REFERENCES

1. Holmdahl, M.: Putting New All Electric Technology Developments to the Test. IEEE NAECON publ. no. 83CH1868-9, Dayton, Ohio, 1983.
2. Tagge, G. E.: Secondary Power With Minimum Engine Bleed. IEEE NAECON publ. no. 83CH1868-9, Dayton, Ohio, 1983.
3. Integrated Application of Active Controls (IAAC) Technology to an Advanced Subsonic Transport Project — Final ACT Configuration Evaluation. NASA CR-3519, Boeing Commercial Airplane Company, 1982.
4. "Weight and Balance Data Reporting Forms for Aircraft." MIL-STD-1374, Part 1, March 1972.
5. Integrated Application of Active Controls (IAAC) Technology to an Advanced Subsonic Transport Project — Test ACT System Description. NASA CR-172221, December 1983.
6. "DATAC MKIV System Specification Draft." Boeing Document D6-52200TN, February 29, 1984.
7. Integrated System Design for Flight and Propulsion Control Using Total Energy Principles. AIAA-83-2561, A. A. Lambregts, October 1983.
8. Integrated Application of Active Controls (IAAC) Technology to an Advanced Subsonic Transport Project — ACT/Control/Guidance System Study — Volume I. NASA CR-165963, December 1982.
9. Integrated Application of Active Controls (IAAC) Technology to an Advanced Subsonic Transport Project — Wing Planform Study and Final Configuration Selection. NASA CR-165630, 1981.

1. Report No. NASA CR-3840		2. Government Accession No.		3. Recipient's Catalog No.	
4. Title and Subtitle SYSTEMS STUDY FOR AN INTEGRATED DIGITAL/ELECTRIC AIRCRAFT (IDEA)				5. Report Date January 1985	
				6. Performing Organization Code	
7. Author(s) G. E. Tagge, L. A. Irish, and A. R. Bailey				8. Performing Organization Report No. D6-52147	
9. Performing Organization Name and Address Boeing Commercial Airplane Company P. O. Box 3707 Seattle, WA 98124				10. Work Unit No.	
				11. Contract or Grant No. NAS1-17528	
12. Sponsoring Agency Name and Address National Aeronautics and Space Administration Washington, DC 20546				13. Type of Report and Period Covered Contractor Report	
				14. Sponsoring Agency Code 505-45-73-01	
15. Supplementary Notes Langley Technical Monitor: Cary R. Spitzer					
16. Abstract This document presents the results of the Integrated Digital/Electric Aircraft (IDEA) Study. Airplanes with advanced systems were defined and evaluated, as a means of identifying potential high-payoff research tasks. A baseline airplane was defined for comparison, typical of a 1990s airplane with advanced active controls, propulsion, aerodynamics, and structures technology. Trade studies led to definition of an IDEA airplane, with extensive digital systems and electric secondary power distribution. This airplane showed an improvement of 3% in fuel use and 1.8% in DOC relative to the baseline configuration. An alternate configuration, an advanced technology turboprop, was also evaluated, with greater improvement supported by digital-electric systems. Recommended research programs were defined for high-risk, high-payoff areas appropriate for implementation under NASA leadership.					
17. Key Words (Suggested by Author(s)) Digital Systems Electric Secondary Power Data Bus Electric Actuation			18. Distribution Statement Unclassified - Unlimited Subject Category 05		
19. Security Classif. (of this report) Unclassified	20. Security Classif. (of this page) Unclassified	21. No. of Pages 222	22. Price A10		

National Aeronautics and
Space Administration

Washington, D.C.
20546

Official Business

Penalty for Private Use, \$300

SPECIAL FOURTH CLASS MAIL
BOOK

Postage and Fees Paid
National Aeronautics and
Space Administration
NASA-451



NASA

POSTMASTER: If Undeliverable (Section 158
Postal Manual) Do Not Return
