

General Disclaimer

One or more of the Following Statements may affect this Document

- This document has been reproduced from the best copy furnished by the organizational source. It is being released in the interest of making available as much information as possible.
- This document may contain data, which exceeds the sheet parameters. It was furnished in this condition by the organizational source and is the best copy available.
- This document may contain tone-on-tone or color graphs, charts and/or pictures, which have been reproduced in black and white.
- This document is paginated as submitted by the original source.
- Portions of this document are not fully legible due to the historical nature of some of the material. However, it is the best reproduction available from the original submission.

Thermal and Cryogenic Study for the
Space Infrared Telescope Facility (SIRTF)

A. R. Urbach
T. K. Kelly
R. Poley

(NASA-CR-166613) THERMAL AND CRYOGENIC
DESIGN STUDY FOR SPACE INFRARED TELESCOPE
FACILITY (SIRTF) (Ball Aerospace Systems
Div., Boulder) 173 p HC AC8/MF A01 CSCL 03A

N85-15793

Unclas
G3/18 13244

CONTRACT NAS2-11549
November 1984

NASA



**Thermal and Cryogenic Study for the
Space Infrared Telescope Facility (SIRTF)**

**A. R. Urbach
T. K. Kelly
R. Poley
Ball Aerospace Division
Boulder, Colorado
F84-14**

**Prepared for
Ames Research Center
under Contract NAS2-11549**

NASA

**National Aeronautics and
Space Administration**

**Ames Research Center
Moffett Field, California 94035**

EXECUTIVE SUMMARY

Overview

Ball Aerospace Systems Division (BASD) has completed the follow-on to its Technology Integrated System Study of the Space Infrared Telescope Facility (SIRTF). The underlying objective of this study is to assess the cryogenic implications of operating SIRTF as a free-flyer in either a 98° sun-synchronous orbit like that of IRAS, or in a low-inclination (28.5°) orbit. We have found that an all-superfluid cryogenic system will give long life in either orbit when used with a suitably designed truncated cone sunshade. Lifetimes as high as 5.8 years appear to be possible without on-orbit servicing.

Background

This study is an extension of one of three parallel studies funded by NASA-Ames Research Center (ARC) to assist in the formulation of the Phase B SIRTF design studies. The BASD follow-on effort was specifically directed to focus on the cryogenic aspects of SIRTF.

The original Technology-Integrated System Studies were based on the assumption that SIRTF would be an STS-attached payload. Since that time, SIRTF has been identified as a free-flying facility, and NASA-ARC has issued a revised Free Flyer Phase A System Concept Description. The concepts and analysis presented here are based on BASD-developed models which incorporate the knowledge gained from the development and flight of IRAS.

The inclination of the SIRTF orbit has not been finalized for a variety of reasons. The two principal candidates are a 700 km 98° sun-synchronous orbit at the dawn/dusk terminator, and a 700 km orbit at 28.5°. The former would be essentially the same as the IRAS orbit and would offer the most benign thermal and operational environment; the latter orbit may permit easier launch and on-orbit servicing because it is compatible with STS flights from Kennedy Space Center but requires a sun avoidance maneuver when the sun is in the orbit plane. The concepts and analytical results presented in this study constitute input to the orbit selection tradeoff.

Study Approach

The study concentrated on exploring these issues:

- The design and performance of the sunshade in the two orbits,

- The impact of orbit choice on the design and performance of the cryogenic system,
- The longest practical mission lifetime achievable without on-orbit servicing, and
- The transient response of the system to changing sunshade heatload and to scientific instrument heatload transients.

The approach used in the study was to work through the following sequence of steps:

- Explore sunshade design and performance for the two orbits,
- Define a reference configuration for the dewar subsystem,
- Analyze the sensitivity of the reference configuration to each of several key design parameters,
- Analyze the response of the system to transient heat loads,
- Define cryogenic system configuration options to emphasize each of several design features.

Hardware Description

Figure 1 shows the overall superfluid helium cryogenic system configuration. A toroidal superfluid helium tank surrounds the SIRTF telescope and the multiple instrument chamber (MIC) containing the scientific instruments. The cryogen tank is surrounded by 3 or 4 vapor-cooled shields (VCSs) which intercept the radiated heat load and transfer it to helium boiloff gas routed through cooling coils. The forward portion of the stray light baffle surrounding the telescope (the forebaffle) absorbs heat radiated or scattered by the sunshade in front of the telescope.

Figure 2 shows that the truncated cone sunshade designs selected for the two orbits are similar in concept, but that the shade required in the 28.5° orbit is substantially larger than that used in the 98° orbit. The high edge of the cone shades the entire interior from direct sunlight, and the low edge shades the aperture from energy scattered or radiated by the earth.

The principal conclusions of the study are summarized as follows:

- The same superfluid helium dewar design can be used for either orbit. The self-regulating characteristic of its vapor cooling system makes its lifetime largely insensitive to aperture heat load.
- The dominant design driver for the cryogenic system lifetime is the power dissipation of the scientific instruments at the focal plane. The thermal conductance between the 2K and 7K stations within each instrument significantly affects the overall system performance, and must therefore be carefully controlled during the instrument development.
- Transients in aperture heat load during the sun-avoidance maneuvers required in 28.5° orbit do not seriously disturb the temperatures of the optical subsystem or the focal plane instruments for the superfluid helium system.
- Truncated-cone designs were selected for the sunshades for both orbits because full-cone designs gave unacceptably high aperture heat loads.
- An orbital maneuvering vehicle (OMV) will be needed to achieve 700 km altitude at either 28.5° or 98° inclination, but should be able to handle the total satellite mass for any of the design options considered.
- A dual-cryogen system offers a slight lifetime advantage over that of an all-superfluid helium system of the same weight. The dual-cryogen system is more complex than the single-cryogen system in terms of flight hardware, ground support equipment required, and launch operations.
- Should aperture heat loads on the fore baffle be significantly greater than predicted in the study, combined with a 10-12K temperature requirement at all times for the baffle, than a dual cryogen system would be recommended for the 28.5° orbit.

The characteristics of the reference configuration and the four principal alternates studied are summarized in Table 1. The reference configuration is a superfluid helium point design that served as a useful starting point for the analysis of the sensitivity of the system to various design parameters. Three all-superfluid alternate configurations were examined to evaluate the impact of designing for either very long life, very low forward baffle temperature, or smaller overall size. For comparison, a dual-cryogen system using solid hydrogen in addition to superfluid helium was also evaluated. These do not represent optimized designs or all of the options, but they do serve to illustrate what sorts of things can be done and to estimate their impact on system performance.

Principal Results

The performance of these five configurations is summarized in Table 2. The masses estimated for the dewar alone and for the total spacecraft are shown, along with the predicted lifetimes in the 28.5° orbit. The lifetime per unit spacecraft mass is a useful figure of merit which leads to these conclusions:

- Large cryogen volumes are more efficient,
- Designing for lower forebaffle temperature entails a 9 percent penalty in lifetime, and
- The dual-cryogen system offers a 10 percent lifetime advantage over the 4000 liter all-superfluid dewar.

The performance data shown are to be taken as illustrating what can be done and what the design drivers are; further work on system optimization will probably increase the lifetimes by up to 20 percent.

The temperature of the forebaffle effects the sensitivity achievable with SIRTf when observing at very long wavelengths. Table 3 summarizes this aspect of performance for three different cryogenic configurations in the two candidate orbits. The principal difference between the all-superfluid helium configurations and the dual-cryogen system is that the latter holds the forebaffle very close to the temperature of the subliming hydrogen. The scientific impact of these temperatures needs to be explored, and a system-level performance/complexity tradeoff must be performed before final conclusions can be drawn.

FIGURE 1. OVERALL CRYOGENIC SYSTEM CONFIGURATION

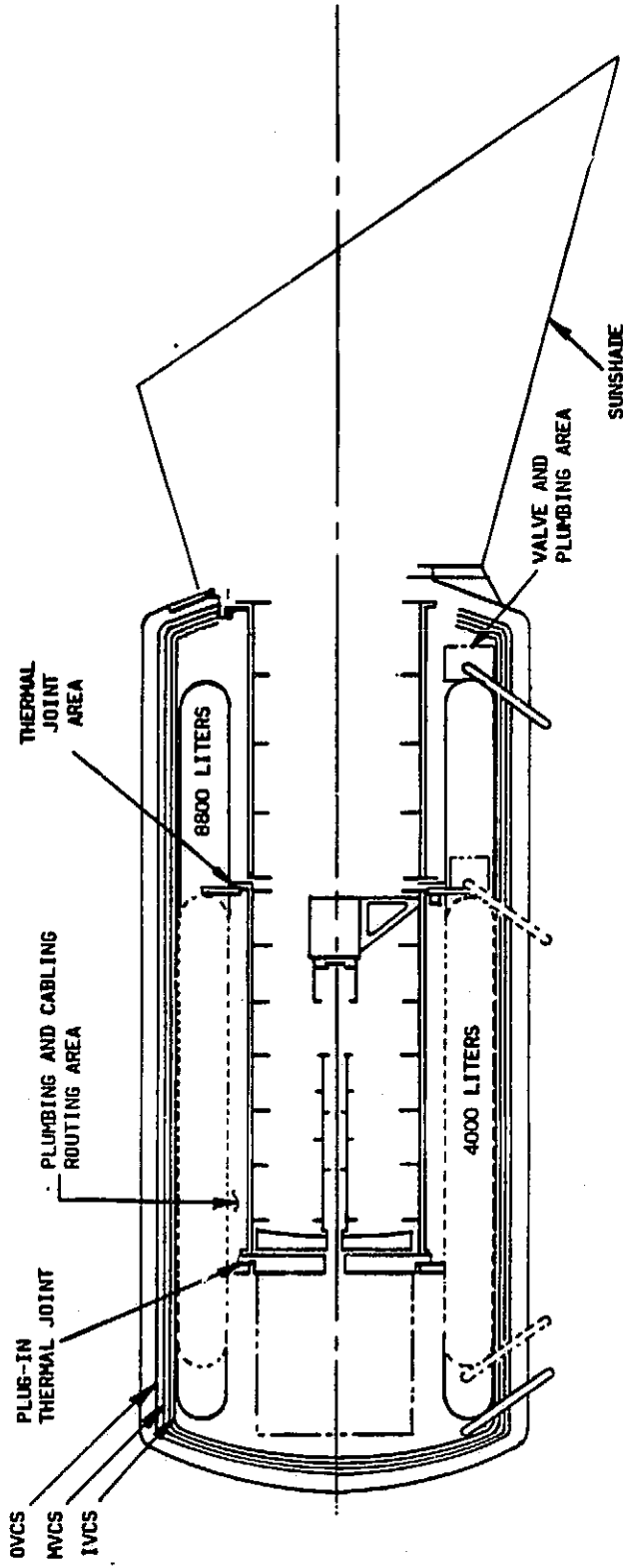

PERFORMANCE OF FIVE CRYOGENIC CONFIGURATIONS

	REFERENCE CONFIGURATION ¹	ALTERNATE CONFIGURATIONS			
		VERY LONG LIFE	COLDER FORE-BAFFLE	SMALLER DEWAR	DUAL CRYOGEN
CRYOGEN(S) (LITERS):					
• SUPERFLUID HELIUM	8800	8800	8800	4000	4000
• SOLID HYDROGEN	---	---	---	---	890
MASS (kg):					
• DEWAR ONLY	3800	3900	3800	2900	3300
• TOTAL SPACECRAFT	5900	6000	5900	5100	5500
LIFETIME ² (YEARS)	4.7	5.8	4.3	2.6	3.1
LIFETIME/MASS ³	.80	.97	.73	.51	.56

1. USED IN STUDY FOR SENSITIVITY ANALYSIS
2. IN 28.5° ORBIT
3. YEARS PER 1000 kg FOR TOTAL SPACECRAFT

FIGURE 2 TRUNCATED CONE SUNSHADE DESIGNS

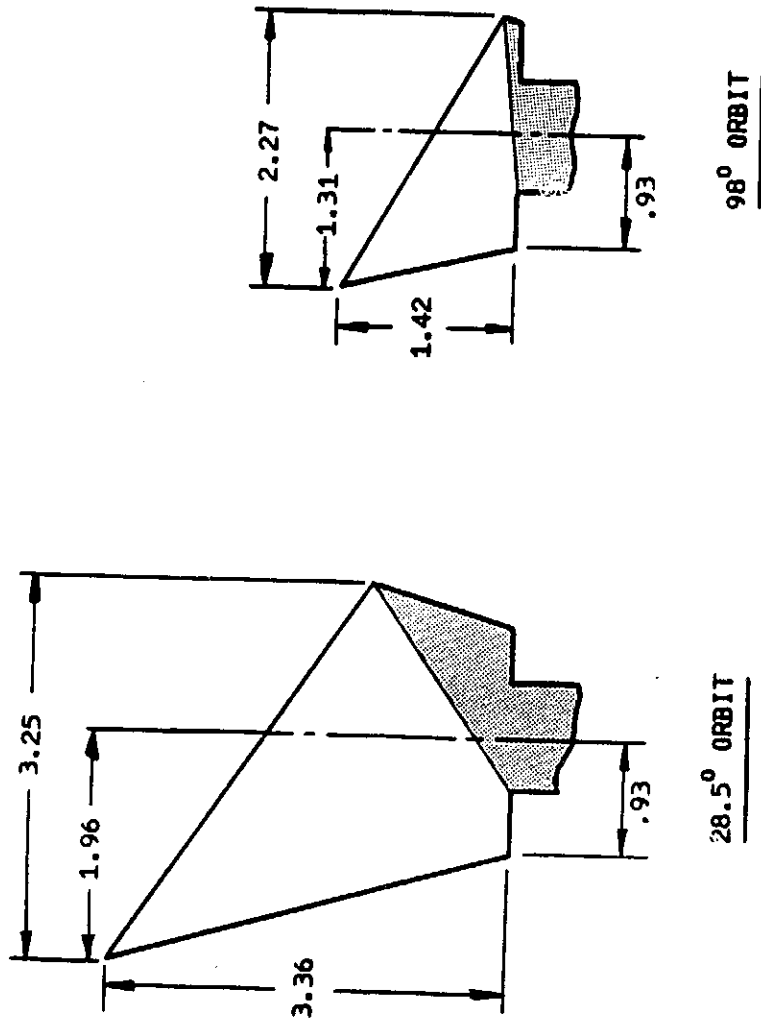

(DIMENSIONS IN METERS)

**TABLE 3
FOREBAFFLE TEMPERATURE FOR THREE CONFIGURATIONS**

	FOREBAFFLE TEMPERATURE (K)		
	REFERENCE CONFIGURATION ¹	COLDER CONFIGURATION ²	DUAL-CRYOGEN ³
28° ORBIT:			
• BEST CASE LIMIT ($\beta = 51^\circ$)	9.8	4.9	10.4
• INTERMEDIATE CASE ($\beta = 0^\circ$, LOOKING NEAR ZENITH EXCEPT DURING SOLAR AVOIDANCE MANEUVER)	12.3 - 14.3	6.6 - 10.3	10.4
• WORST CASE LIMIT ($\beta = 0^\circ$, TIPPED TOWARD EARTH LIMB 100% OF TIME)	15.8 - 16.8	9.6 - 11.8	10.4
98° ORBIT:			
• BEST CASE LIMIT (LOOKING NEAR ZENITH)	9.3	4.5	≈ 10.0
• WORST CASE LIMIT (TIPPED TOWARD EARTH LIMB 100% OF TIME)	10.0	5.1	≈ 10.0

1. FOREBAFFLE ATTACHED TO INNER VAPOR-COOLED SHIELD
2. FOREBAFFLE ATTACHED TO AFT BAFFLE
3. FOREBAFFLE ATTACHED TO SOLID HYDROGEN TANK

LIST OF ACRONYMS

ARC	- AMES RESEARCH CENTER	OMV	- ORBITAL MANEUVERING VEHICLE
BASD	- BALL AEROSPACE SYSTEMS DIVISION	OVCS	- OUTER VAPOR COOLED SHIELD
FGS	- FINE GUIDANCE SENSOR	OS	- OUTER SHELL
GHe	- GASEOUS HELIUM	SfHe	- SUPER FLUID HELIUM
GSE	- GROUND SUPPORT EQUIPMENT	SH ₂	- SOLID HYDROGEN
IR	- INFRARED	SIRTF	- SPACE INFRARED TELESCOPE FACILITY
IVCS	- INNER VAPOR COOLED SHIELD	STICCRS	- SIRTf TELESCOPE INSTRUMENT CHANGEOUT AND CRYOGEN REPLENISHMENT STUDY
LHe	- LIQUID HELIUM	STS	- SPACE TRANSPORTATION SYSTEM
MCT	- MAIN CRYOGEN TANK	VCS	- VAPOR COOLED SHIELD
MIC	- MULTIPLE INSTRUMENT CAVITY	VDA	- VACUUM DEPOSITED ALUMINUM
MLI	- MULTILAYER INSULATION		
MVCS	- MIDDLE VAPOR COOLED SHIELD		

TABLE OF CONTENTS

SECTION	TITLE	PAGE NO.
	EXECUTIVE SUMMARY	iii
	ACRONYMS LIST	xi
1.0	STUDY OVERVIEW	1
2.0	STUDY PARAMETERS AND ORBIT CONSIDERATIONS	11
3.0	CRYOGENIC SYSTEM OVERVIEW	17
4.0	SUNSHADE ANALYSIS	29
5.0	SUPERFLUID HELIUM CRYOGEN SYSTEM THERMAL ANALYSIS	57
5.1	THERMAL ANALYSIS OVERVIEW	61
5.2	THERMAL MATH MODEL	65
5.3	REFERENCE CONFIGURATION SYSTEM PERFORMANCE	77
5.4	SENSITIVITY ANALYSES	93
5.5	SECONDARY MIRROR COOLDOWN	135
5.6	8800 AND 4000 LITER DEWAR COMPARISON	139
5.7	CONFIGURATION OPTIMIZATION	143
5.8	THERMAL ANALYSIS SUMMARY AND CONCLUSIONS	149
6.0	DUAL CRYOGEN (SiHe/SH ₂) SYSTEM EVALUATION	157
7.0	SINGLE/DUAL CRYOGEN SYSTEM COMPARISONS	171
8.0	STUDY CONCLUSIONS AND PHASE B RECOMMENDATIONS	181

SECTION 1.0
STUDY OVERVIEW

STUDY REPORT ORGANIZATION

This study report is organized in the following way.

Section one is the study overview which states the study objectives and areas of concern in statement of work such as whether a superfluid helium cryogen system could operate in a 28.5° inclination orbit as well as a 98° IRAS-like orbit. Also included in the overview is a statement of the system topics evaluated during the study.

Following the study overview is a list of the study requirements which were derived as the first task of this study. Also included is a brief discussion of the two orbits to be considered and launch vehicle capability versus SIRTIF satellite mass and altitude requirements.

To set the stage for the study, an overview of a SHe cryogenic system which might be used for SIRTIF is presented as a reference configuration. This configuration was used as a starting point to conduct sensitivity trades to determine which of the many elements in the system have the greatest effect on lifetime and telescope temperatures. Also included in the configuration overview section is a fluid management scheme which identifies the cooling scheme for the various telescope elements and also the components required to control the cryogen flow.

One of the most critical elements on the satellite is the sunshade. Its design varies depending on orbit and viewing scenario. The first part of the section describes the parameters which control the sunshade design and is followed by the performance of four different sunshade configurations for each of the two orbits. Since surface finish properties play an important role in the heat loads which are incident on the forebaffle, a section is devoted to discussion of surface finishes and effects of contamination. The results of the sunshade analysis are used as inputs to the thermal analysis section.

The superfluid helium cryogen system thermal analysis is the major study report section. It describes the method of analysis, which is graphically displayed as a thermal model, then presents the cryogenic system reference configuration performance which is used as a baseline from which to vary the performance of the system elements. This sensitivities analysis is used later in the section to demonstrate how lifetime or forebaffle temperature might be optimized. The cryogenic system lifetime and telescope temperatures will all be effected by the viewing scenario and amount of heat load incident to the forebaffle. Since the viewing scenario will be a function of the mission operations

and the scientific instruments, no specific viewing scenario was assumed. Rather, a best and worst case scenario of looking at zenith and at the earth limb was assumed. The resulting heat loads were used to determine lifetime and telescope temperatures.

8800 and 4000 liter superfluid helium tank sizes were evaluated during the study. Their performance is summarized in regards to lifetime, temperature, and weight in a table just ahead of the conclusions derived while performing the single cryogen system thermal analysis.

Another concept which might be used for SIRTIF is a dual cryogen system also called a hybrid system. It utilizes the large heat of sublimation of solid hydrogen to absorb heat loads incident on the forebaffle in the 28.5° inclinations orbit to maintain the forebaffle at constant temperature. Four dual cryogen system configurations and their performance are listed, followed by a comparison between the dual cryogen and single cryogen systems. Included in this section are overall system considerations such as types of cryogenic GSE required, complexity of the two systems, and launch tower operations which must be performed.

The last section in the report presents the total study conclusions as well as recommendations for the phase B study.

STUDY OBJECTIVES

- DEVELOP SIRTF CRYOGENIC SYSTEM FREE FLYER CONCEPTS
- PRESENT MOST REALISTIC ANALYSIS BASED ON IRAS EXPERIENCE
- DETERMINE SENSITIVITIES OF ELEMENTS TO MAXIMIZE LIFETIME IN FREE FLYER MODE
- DETERMINE IMPACT OF APERTURE HEAT LOADS
- DETERMINE IF S_fHe MEETS REQUIREMENTS IN LOW INCLINATION ORBIT

PRECEDING PAGE BLANK NOT FILMED

STUDY AREAS REQUIRED IN THE STATEMENT OF WORK

1. Orbit Inclination Impact on Cryogenic Subsystem.
Concern existed relative to the higher heat loads incurred in the 28.5° inclination orbit and whether lifetime, fore baffle temperature, and secondary mirror temperature requirements could be achieved. Either an all SfHe system or a dual cryogen SfHe/SH₂ system can meet these requirements.
2. Sunshade Geometry
Concern existed if a sunshade could be designed to sufficiently limit aperture heat loads in the 28.5° orbit.
3. Maximum satellite lifetime is always a desirable feature. The largest cryogen tank possible was to be evaluated to determine just how long a lifetime might be achieved for SIRTF without resorting to cryogen replenishment. With a 8800 liter SfHe system, 5.8 years can be achieved.
4. The thermal stability of the optical interfaces refers to the aperture heat load addressed in item 1. The instrument stability concern was in regards to transients during cycling instruments on and off and having two on at the same time. With existing joint conductance technology all instrument temperature requirements can be achieved.

STUDY AREAS REQUIRED IN THE STATEMENT OF WORK

- **ORBIT INCLINATION IMPACT ON CRYOGENIC SUBSYSTEM**
- **SUNSHADE GEOMETRY**
- **MAXIMIZE CRYOGEN LIFETIME UTILIZING LARGEST CRYOGENIC SYSTEM ENVELOPE PERMITTED BY SPACE TRANSPORTATION SYSTEM**
- **THERMAL STABILITY OF OPTICAL AND SCIENTIFIC INSTRUMENT INTERFACES DURING TRANSIENT OPERATIONS**

TRADES AND EFFORTS COMPLETED

1. Sunshade configurations studied included a truncated and a full cone for the 28.5° inclination and a truncated cone for the 98° inclination orbit.
2. Cryogen lifetime can be improved by adjusting certain parameters or elements in a dewar design. Eight major elements in the reference configuration were evaluated for effect on lifetime.
3. Since the dual cryogen (hybrid) system has been considered for the 28.5° inclination orbit it was appropriate to evaluate and compare it in this study to the SfHe system.
4. To evaluate the cryogenic systems application for the SIRTf mission we also listed the required support equipment and identified some of the integration procedures and launch operations.

TRADES AND EFFORTS COMPLETED

- SUNSHADE CONFIGURATIONS STUDIED FOR BOTH 98° AND 28.5° INCLINATION, 700 km ORBITS WERE COMPLETED
- CRYOGEN LIFETIME SENSITIVITY TRADES WERE CONDUCTED FOR:
 - INSTRUMENT POWER
 - OUTER SHELL TEMPERATURE
 - SUPPORTS
 - APERTURE HEATING
 - CHOPPER MOTOR POWER
 - 4 VAPOR COOLED SHIELDS DISSIPATION
 - FOREBAFFLE MOUNTING AND ISOLATION
 - 7K INSTRUMENT STATION
- A DUAL CRYOGEN SYSTEM WAS EVALUATED
- CRYOGENIC GROUND SUPPORT EQUIPMENT WAS COMPARED FOR THE TWO CRYOGENIC SYSTEMS
- INTEGRATION AND LAUNCH OPERATIONS FOR EACH SYSTEM WERE INVESTIGATED

SECTION 2.0
STUDY PARAMETERS
AND
ORBIT CONSIDERATIONS

PRECEDING PAGE BLANK NOT FILMED

PARAMETERS USED FOR CRYOGEN STUDY

1. Thermal -

A secondary mirror temperature of less than 3K permits a differential temperature excursion of up to 0.9K during chopping. Absolute temperature requirement is a function of the scientific instruments and must be reviewed by the science team. This is also true for the forebaffle temperature. Temperature limits must be established based on the actual viewing scenario and the instrument requirements.

2. Mechanical -

The envelope limits are somewhat arbitrary and can be increased based on the shuttle bay envelope presented later. The envelope is of sufficient size to accommodate a dewar of greater than 10,000 liters. The telescope permits space for exterior mounted electronics boxes and a center mounted spacecraft. The smallest size dewar studied was 4000 liters and the largest was 8800 liters. The 8800 liter SFHe system with a 12% ullage was used as the reference configuration for the sensitivity studies.

3. Mission -

There are advantages for each of the two different orbit inclinations, this study evaluated each inclination to determine feasibility of the orbits from a thermal and cryogenic point of view.

PARAMETERS USED FOR CRYOGEN STUDY

I. THERMAL

- OPTICS — PRIMARY AND SECONDARY MIRROR: < 4K
 - FORE BAFFLE: TBD
 - MIC
 - WALLS ≤ 4K
 - HEAT SINKS 2K
 - 7K
 - 50 mW AVG
 - 150 mW PEAK
 - 150 mW
- SCIENTIFIC INSTRUMENT POWER

II. MECHANICAL

- ENVELOPE
- 285 cm DIA x 850 cm LONG, OUTER SHELL
- 380 cm DIA, TELESCOPE
- ENVIRONMENT — SHUTTLE
- CRYOGEN MASS — 580 kg (4000 LITER) MIN.

III. MISSION

- LIFETIME
- MAXIMUM POSSIBLE WITH ABOVE ENVELOPE, GOAL OF 2 YEARS MINIMUM WITH 33% MARGIN
- ORBIT — 700 km
- 28.5° INCLINATION
- 98° INCLINATION SUN SYNC OVER TERMINATOR

ORBIT CONSIDERATIONS

Altitude -

The altitude of 700km was listed as a requirement in the study statement of work. The justification for this requirement is a high enough altitude to minimize air contamination on the telescope, to permit a reasonable viewing scenario and orbit decay, and to provide an orbit which has a slightly lower radiation environment than experienced by IRAS at 900 km.

Inclination -

The orbit inclination selection is not only a technical decision but also a programmatic one. From a shuttle availability standpoint the 28.5° Inclination is highly desirable; also it's the most likely orbit for the Space Station. During the period of time the sun is in the orbit plane the viewing scenario will be limited.

OMV -

Based on the present 700km orbit and anticipated satellite weight SIRTIF will probably require additional propulsion capability to achieve orbit. The STS with this mass does not attain 700 Km in any inclination, but the OMV as presently planned can retrieve and redeploy a 7500 KG satellite to 700 Km or deploy greater than 15,000 KG to 700 Km in a 98° inclination orbit. The largest satellite considered (8800 liter dewar) weighs approximately 6000 KG. The 4000 liter dewar and dual cryogen system satellites weigh approximately 5400 KG.

Data for the OMV and STS was derived from pages 3-34 and 3-35 of NASA Document No. PD-1006, titled SIRTIF Free Flyer Phase A System Concept Description dated May 3, 1984.

ORBIT CONSIDERATIONS

ALTITUDE — 700 km REQUIRED, BEST COMPROMISE BETWEEN VIEWING SCENARIO, CONTAMINATION, ORBIT DECAY, AND RADIATION PARAMETERS

INCLINATION —

- 28.5°
 - LAUNCH ALTITUDE 420 km for 7250 kg USING STANDARD INSERTION, OR 620 km USING DIRECT INSERTION
 - MOST LIKELY INCLINATION FOR SPACE STATION
 - MORE LAUNCHES AVAILABLE
 - MOST DIFFICULT VIEWING SCENARIO AND HIGHEST APERTURE HEAT LOAD
- 98°
 - LAUNCH ALTITUDE OF 320 km FOR 7250 kg USING STANDARD INSERTION, DIRECT INSERTION NOT AVAILABLE
 - EASIEST VIEWING SCENARIO
 - LEAST CRYO IMPACT

OMV — REQUIRED FOR EITHER INCLINATION

SECTION 3.0

CRYOGENIC SYSTEM OVERVIEW

PRECEDING PAGE BLANK NOT FILMED

MAXIMUM ALLOWABLE SATELLITE ENVELOPE

The facing page portrays a cross section of the available STS Bay.

1. Note the 380 cm satellite diameter permits margin within the trunnions for growth.
2. The sunshade shown is the smallest configuration derived in the sunshade analysis for the 28.5 inclination orbit.
3. The shuttle bay size is not the critical parameter, weight and orbit altitude are the driving parameters.

MAXIMUM ALLOWABLE SATELLITE ENVELOPE

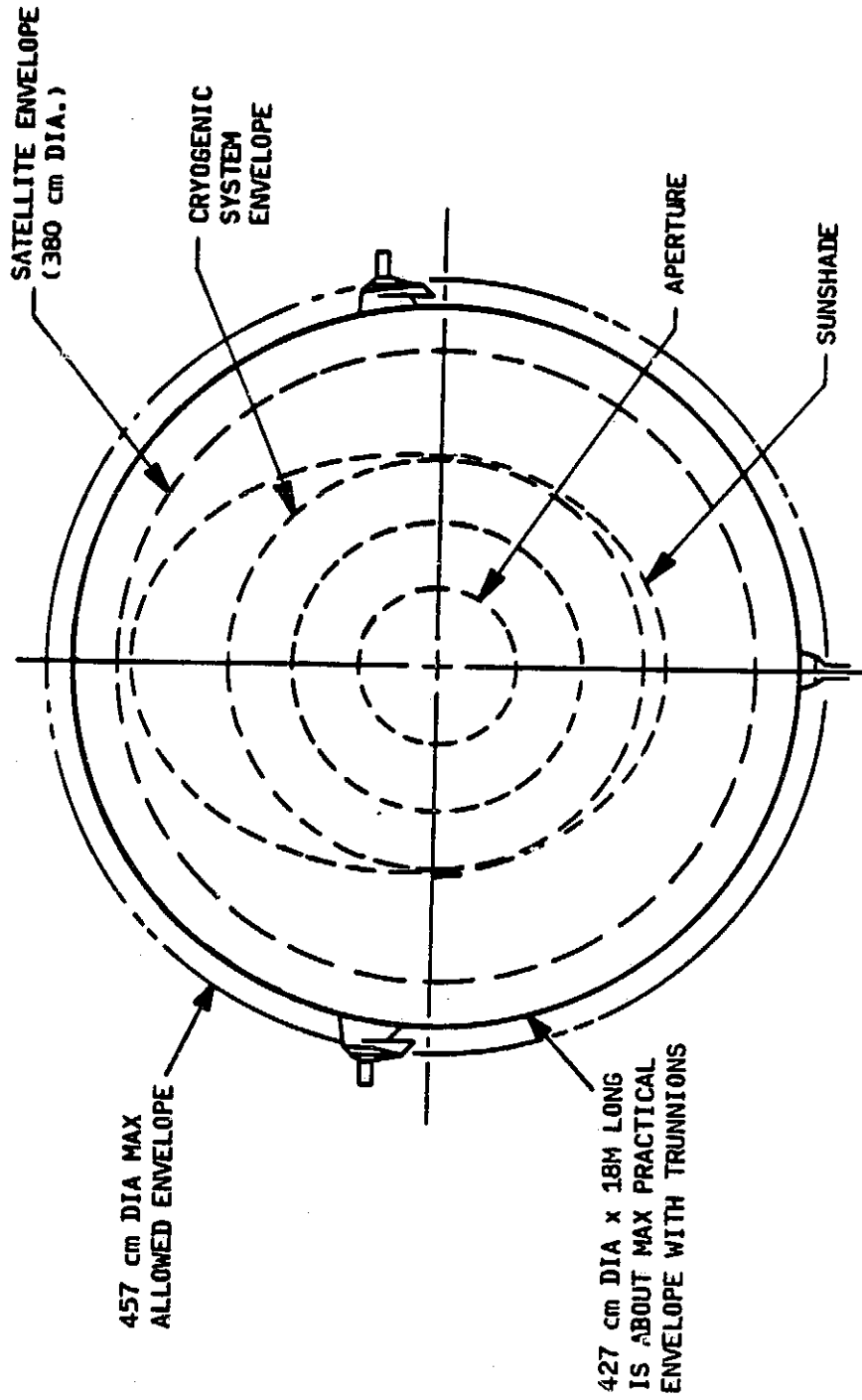

SIRTF SFHe CRYOGENIC SYSTEM

The cryogenic system configuration studied for SIRTF consists of a 0.85 meter telescope with a 0.90 meter aperture. Optical requirements determine the actual configuration, especially the length. An annular toroidal cryogen tank was sized to surround the multiple instrument chamber and telescope with margin for plumbing and cable routing between the tank and telescope.

The baseline system design assumes a plug-in type telescope with a bolted thermal connector at the top of the cryogen tank (could also be located in the center of the tank to minimize thermal path to the MIC) and a plug in thermal joint at the baseplate/MIC interface. Cryogen tank sizes evaluated were the 4000 liter size required and the 8800 liter tank size. Surrounding the cryogen tank are three vapor cooled shields spaced by multilayer insulation. One of the tradeoffs evaluated was the effect of a fourth vapor cooled shield. The cryogen tank is supported by 12 fiberglass tension straps which also support the vapor cooled shields and are in turn cooled by the vapor cooled shields. The fore baffle may be attached either to a stiffened inner vapor cooled shield, or through a thermal isolator, to the aft baffle. The secondary mirror may be conductively coupled to the aft baffle and the chopper heat load absorbed in the cryogen tank or thermally insulated but mounted to the aft baffle and cooled with the effluent GHe from the cryogen tank.

The outer shell provides the vacuum enclosure for the cryogenic system and the aperture is sealed by a cryogen tank similar to that used on IRAS. Should cryogen on-orbit replenishment be performed, an aperture shutter could be incorporated to protect against line of sight contamination. The sunshade will be some form of a truncated cone with the exact configuration determined by the orbit selected.

SIRTF SHe CRYOGENIC SYSTEM

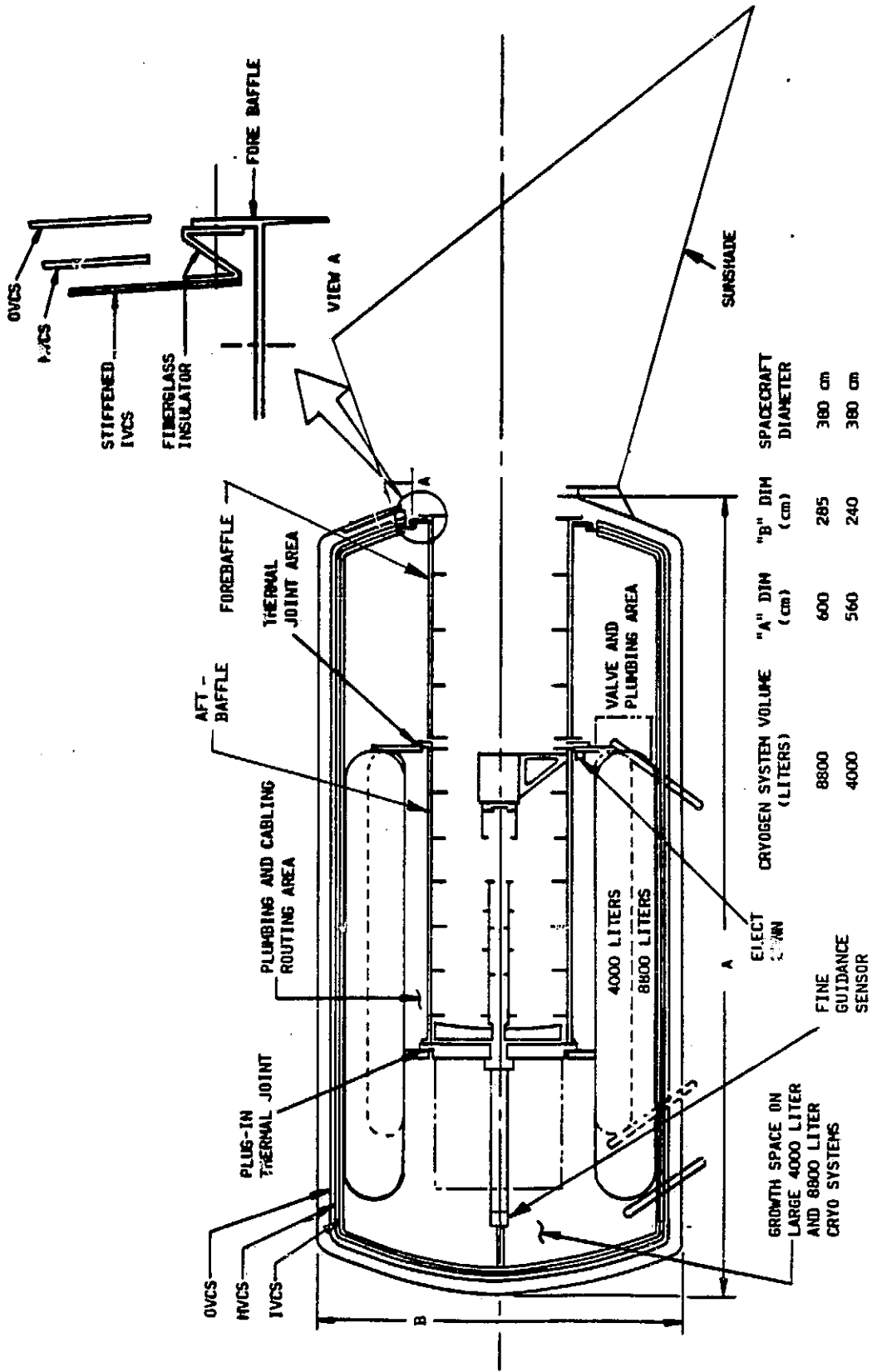

TELESCOPE ELEMENTS COOLING TECHNIQUES

ELEMENT

COOLING TECHNIQUE

- MULTIPLE INSTRUMENT CAVITY
2K TEMPERATURE STATION CONDUCTION TO CRYOGEN TANK
- PRIMARY MIRROR CONDUCTION TO CRYOGEN TANK
- SECONDARY MIRROR COOLED BY EFFLUENT GHe (FIRST STAGE OF COOLING) AND CONDUCTION
- MULTIPLE INSTRUMENT CAVITY COOLED BY EFFLUENT GHe (SECOND STAGE OF COOLING)
- FOREBAFFLE - MOUNTED THROUGH COOLED BY EFFLUENT GHe (THIRD STAGE OF INSULATOR TO IVCS COOLING)
- VAPOR COOLED SHIELDS, SUPPORTS COOLED BY EFFLUENT GHe AND WIRES

NASA/ARC MODEL VARIATIONS FROM BASD REFERENCE CONFIGURATION:









- SECONDARY MIRROR HARD MOUNTED TO AFT BAFFLE AND THEN TO CRYOGEN TANK
- FORE BAFFLE MOUNTED TO AFT BAFFLE THROUGH A THERMAL INSULATOR

WIRES

SfHe SYSTEM FLUID MANAGEMENT SCHEME

This schematic pictorially displays the cooling previously listed. It uses the same versatile scheme used on IRAS and consists of five flow control valves for directing the fluid flow during fill, SfHe topoff, and normal operating modes. The first stage of effluent GHe cooling is directed to the secondary mirror and then to the 7K MIC station. The refrigeration of the GHe than is used to cool the vapor cooled shields. A sixth valve might be added in parallel with V5 for redundancy. Bursè disks are included on each line for safety.

SIRTF SHe SYSTEM FLUID MANAGEMENT SCHEMATIC

-  ELECTRICAL VALVE
-  BAYONET COUPLING
-  BURST DISK
-  POROUS PLUG
-  RELIEF VALVE
-  2K COOLING STATION
-  7K COOLING STATION
-  THERMAL CONNECTION

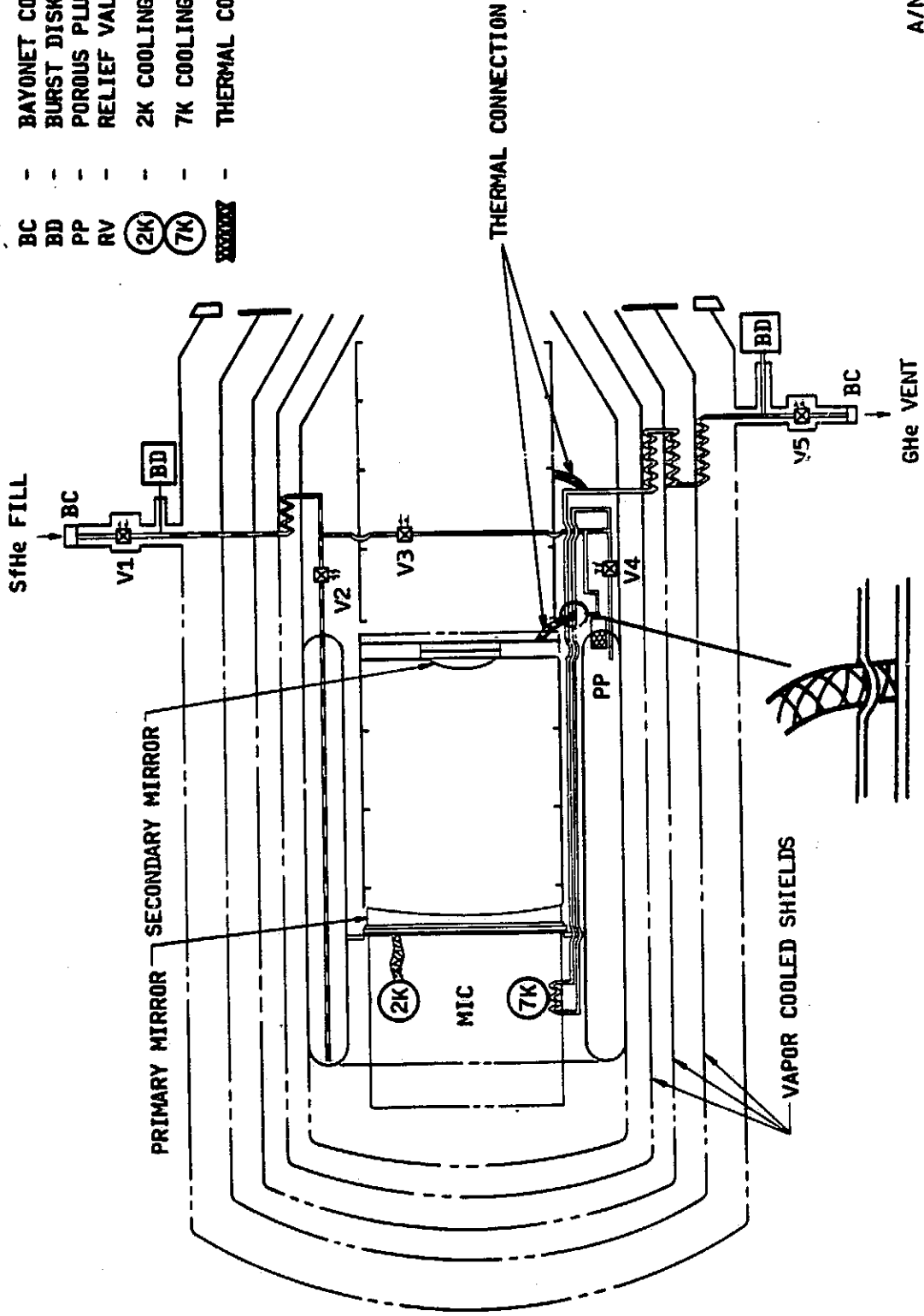

A/N 4742

STRUCTURAL CONSIDERATIONS

The study was primarily a thermal analysis of the cryogenic system. But, to assure realism of the analysis, a preliminary weight analysis was performed to use for sizing the support straps.

STRUCTURAL CONSIDERATIONS

- SUPPORT STRAP RESONANT FREQUENCY:
 - 4000 LITER DEWAR - > 30 Hz, LATERAL AND AXIAL
 - 8800 LITER DEWAR - > 40 Hz, LATERAL AND AXIAL

- OPERATING PRESSURE: 36 psia

- CRYOGEN SYSTEM WEIGHT:
 - 4000 LITER SYSTEM 2900 Kg
 - MAIN SHELL 1330 Kg
 - INSULATION SYSTEM 320 Kg
 - CRYOGEN TANK 670 Kg
 - CRYOGEN 580 Kg

- 8800 LITER SYSTEM 3800 Kg
- MAIN SHELL 1330 Kg
- INSULATION SYSTEM 320 Kg
- CRYOGEN TANK 875 Kg
- CRYOGEN 1275 Kg

SECTION 4.0

SUNSHADE ANALYSIS

PRECEDING PAGE BLANK NOT FILMED

SUNSHADE TOPICS COVERED

- ORBITAL GEOMETRY
- TRUNCATED SUNSHADE GEOMETRY
- MONTE CARLO LOGIC
- 28.5° ORBIT MAXIMUM HEAT LOADS
- FULL CONE MAXIMUM HEAT LOADS
- 98° ORBIT MAXIMUM HEAT LOADS
- SURFACE FINISHES
- 28.5° ORBIT FOREBAFFLE TRANSIENT BEHAVIOR
- 28.5° ORBITAL TIMELINE
- CONCLUSIONS

PRECEDING PAGE BLANK NOT FILMED

GEOMETRY WITH SUN IN ORBIT PLANE

For a polar, sun-synchronous, dawn-dusk orbit (like the IRAS orbit), the earth avoidance angle and the sun avoidance angle are basically free parameters that can be derived from the desired viewing scenario.

If the orbit is not sun-synchronous, then the sun will eventually appear in the orbit plane, as shown on the facing page. The earth half-angle is determined from the equation

$$\sin \delta = R/(R+h)$$

where R = Radius of the earth and h = Orbital Altitude for a 700 km orbit, $\delta = 64.3^\circ$.

The sum of the earth avoidance angle (ϵ) and the sun avoidance angle (σ) must then be equal to 180° . For a full cone sunshade it is possible to shield the plane at the bottom of the cone (containing the aperture and a radiator) from direct illumination by either the earth or the sun. This is done by setting the earth avoidance angle (ϵ) equal to the sun avoidance angles (δ). If these angles are not equal, the plane of the aperture will be directly illuminated by the object whose avoidance angle is the smaller. Thus, if $\epsilon < \delta$, the plane of the aperture will be directly illuminated to some degree by the earth.

For purposes of this study, we have chosen to keep $\delta = \epsilon$ for both the full cone and the truncated cone.

GEOMETRY WITH SUN IN ORBIT PLANE

- ORBITAL GEOMETRY WHICH
DEFINES SUNSHADE PARAMETER
AND SUN-AVOIDANCE CONFIGURATION

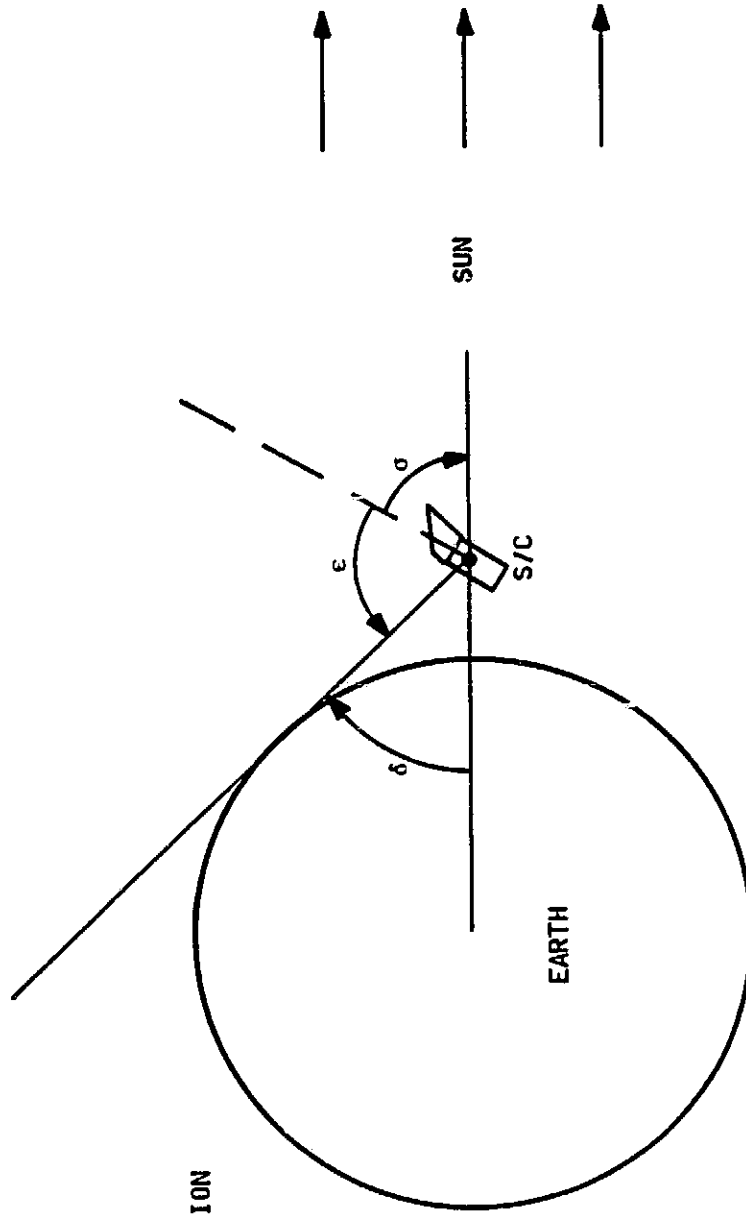

- δ = EARTH HALF ANGLE
- ϵ = EARTH AVOIDANCE ANGLE
- σ = SOLAR AVOIDANCE ANGLE

$$\delta + \epsilon + \sigma = 180^\circ$$

LAYOUT OF TRUNCATED CONE

The truncated cone is laid out in the following manner:

- The radius of the radiator is selected. This determines points 2 and 4.
- The amount of radiator shading is determined. This locates point 1 somewhere between the edge of the aperture and point 4.
- Angle $A = 90^\circ$ - earth avoidance angle. The half-angle of the cone should not be less than $A/2$.
- Knowing angles A and $A/2$, it is possible to locate point 3 at the intersection of line 1-3 and line 2-3.
- Angle $B = 90^\circ$ - solar avoidance angle. Knowing angle B , it is possible to locate point 5 at the intersection of line 3-5 and line 4-5.

LAYOUT OF TRUNCATED CONE.

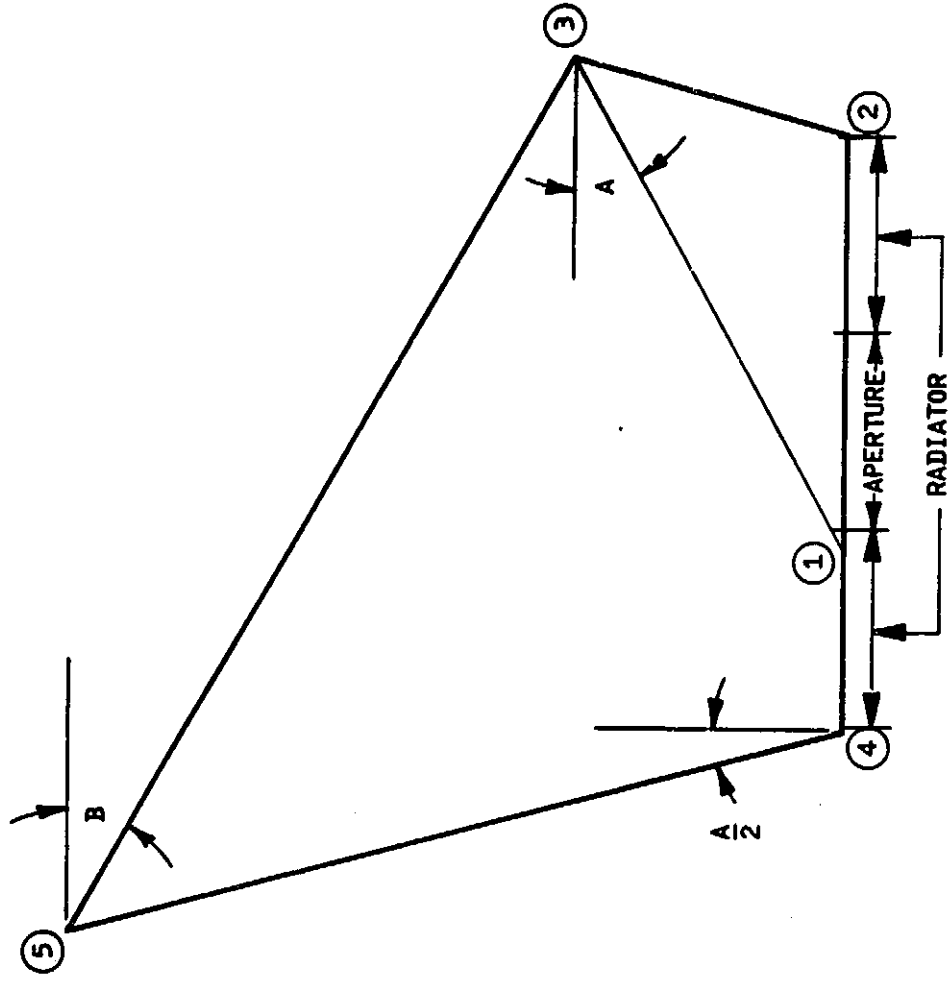

Logic Flow for Monte Carlo Program

The Monte Carlo program was used to calculate all radiation interchange factors and absorbed orbital fluxes (earthshine, albedo, and solar).

1. A ray is launched from a node. The program allows rays to be launched either collimated or in a lambertian distribution. Collimated rays are used to simulate solar flux; otherwise we used lambertian distribution.
2. All possible intersections of the ray with all surfaces are calculated. From this information the intersection of the ray with the nearest node is determined.
3. A random number, R , is selected. If $0 < R < \epsilon$, the ray is absorbed, and we return to Step 1. If $1 - p_s < R < 1$, the ray is specularly reflected, and we return to Step 2. If $\epsilon < R < 1 - p_s$, the ray is diffusely reflected. A random direction conforming to a lambertian distribution is selected and we return to Step 2.

Each ray is traced through the system until it is absorbed by a node. Then another ray is launched and the whole procedure starts over again. We launch a pre-determined number of rays from a surface, and when all of these rays have been traced, we summarize and print out the results, showing the number of hits on each node, the radiation interchange factors, and the earthshine or albedo, as appropriate.

LOGIC FLOW FOR MONTE CARLO

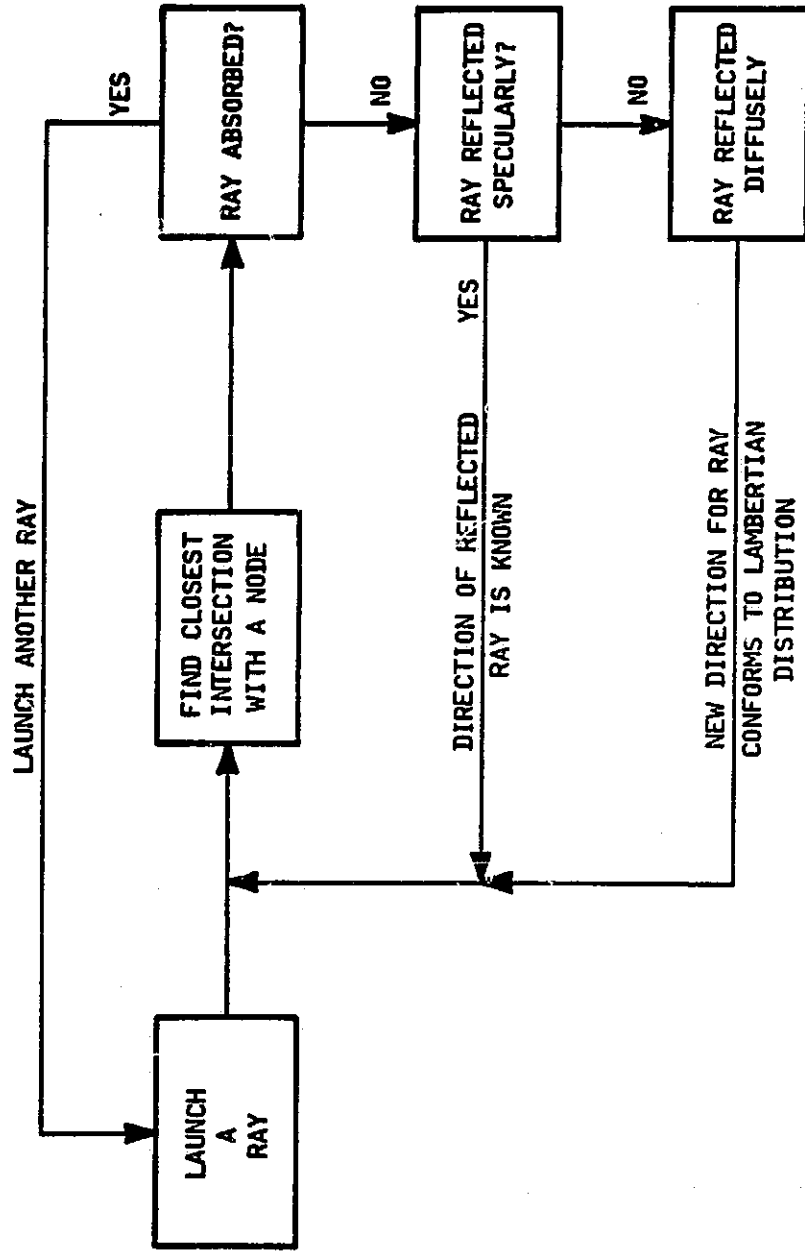

28.5° TRUNCATED CONE SUNSHADE DESIGN

The facing page summarizes our studies for the truncated cone in the 28.5° inclination orbit. We have used two different sizes of radiators and two different levels of radiator shadowing.

The inside of the cone was vacuum-deposited aluminum (VDA) with the following nominal properties at 153K:

```

ε.....= 0.017
IR DIFFUSENESS.....= 0.007
αS.....= 0.100
SOLAR DIFFUSENESS = 0.020

```

The radiator had no specular component, and was white paint with $\epsilon = 0.90$ and $\alpha_S = 0.21$.

The forebaffle was assumed to be perfectly black; $\epsilon = \alpha_S = 1$.

All values for earth IR and albedo are maximum absorbed values with the cone at the subsolar point and the sun in the orbit plane. The radiated load on the forebaffle from the cone is approximately constant throughout the orbit because of the small variation in the cone temperature. The time-line used to calculate the orbital average cone temperature is shown on a later page. Actual cone temperature orbital variation is approximately average $\pm 3K$ for all geometries. All cones were designed for earth avoidance and sun avoidance angles of 57.85°.

The cones sized for partial radiator shadowing result in lower maximum heat loads to the forebaffle than these cones sized for full radiator shadowing because the cones are smaller. Thus, the cone-radiator combinations have a lower total maximum heat load in the partially shadowed cases resulting in lower cone temperatures and lower radiated heat loads to the forebaffle. The 93-cm partially shadowed configuration has a lower maximum total heat load to the forebaffle than the 120-cm partially shadowed configuration because, although the cone temperature and the radiated component is larger, the view factor between the cone and the forebaffle is smaller, so the scattered earthshine and albedo reaching the forebaffle is less.

The design yielding the smallest heat load on the forebaffle is the 93 cm radiator, partially shadowed. This has been selected as the reference configuration.

28.5° INCLINATION ORBIT SUNSHADE DESIGN PERFORMANCE (SUBSOLAR POINT, MAXIMUM EARTH IR AND ALBEDO)

	REFERENCE CONFIGURATION			
CONE AREA (m²)	40.0	24.1	29.0	18.6
EARTH IR (W)	24.1	14.6	19.59	12.2
ALBEDO (W)	235.5	142.3	189.7	118.3
RADIATOR AREA (m²)				
EARTH IR (W)	3.89	2.08	3.89	2.08
ALBEDO (W)	.56	.32	.69	.36
	.43	.257	.54	.265
			1.23	0.62
FORWARD BAFFLE LENGTH (m)				
EARTH IR (W)	1.99	2.11	1.85	2.01
ALBEDO (W)	.170	.154	.155	.143
RAD (W)	.325	.259	.311	.262
	.149	.168	.126	.145
		.581	.592	.550
CONE TEMPERATURE (K) (ORBITAL AVERAGE)	132.	141.	128.	136.

BOXED VALUES ARE TOTAL HEAT LOADS IN WATTS

28.5° FULL CONE DESIGN

Tabulated values in the box on the facing page are instantaneous absorbed heat loads at the subsolar point and sun in the orbit plane. Radiation is based on assumed orbital average cone temperatures. With instantaneous heat loads of over three watts on the forebaffle, and with the danger of photopolymerizing any contaminants on the inside of the cone, we felt that this approach did not warrant any more attention.

28.5° INCLINATION ORBIT FULL CONE DESIGN NOMINAL VDA FINISHES AT 283K

CONE AREA	18.8m ²
EARTH IR7W
ALBEDO37W
DIRECT SOLAR	1898W
RADIATOR AREA	
EARTH IR	3.89m ²
ALBEDO	0.22W
SCATTERED SOLAR	0.10W
SCATTERED SOLAR	7.34W
FORWARD BAFFLE:	
● EARTH IR	0.04W
● ALBEDO	0.19W
● SCATTERED SOLAR	2.45W
● RADIATED FROM CONE	1.19W
TOTAL	3.87W

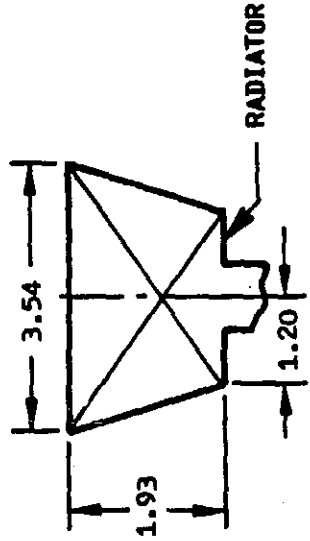

RADIATION FROM CONE TO FORWARD BAFFLE:

CONE AT 283K RAD = 4.76W

CONE AT 200K RAD = 1.19W

98° TRUNCATED CONE SUNSHADE DESIGN

The facing page summarizes our studies for the truncated cone in the 98° polar, sun-synchronous, dawn-dusk orbit. Surface finishes are the same as for the 28.5° truncated cone. All heat loads are for the cone tipped toward the earth, tip angle of 30° off zenith. There is no albedo contribution because the orbital path is over the terminator. All tabulated values are absorbed heat loads.

Because the heat loads to the forebaffle are so similar for these four cases, we recommend the smallest cone (93 cm radiator, partially shadowed) because it will make pointing control the simplest. We have thus selected this smallest cone as the reference configuration.

A brief comparison of the reference configuration and the IRAS sunshade is appropriate. The reference configuration has an area 2.1 times larger than the IRAS configuration. The radiated energy into the IRAS aperture, after adjustments for surface finish and cone temperature, is 6.7 mW as compared to 13.5 mW for the reference configuration. The earthshine into the aperture in the extreme tip condition is 11.6 mW for IRAS (adjusting for surface finish) as compared to 18.7 mW for the reference configuration. BASD used the IRAS configuration to check out the Monte Carlo program described above. Results matched within four percent.

Design limits on the truncated cone are 60° solar avoidance, 85.7° earth avoidance.

98° INCLINATION ORBIT SUNSHADE DESIGN PERFORMANCE (TIPPED 30° OFF ZENITH, LOWSIDE TOWARDS EARTH)

REFERENCE
CONFIGURATION

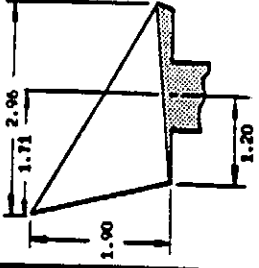
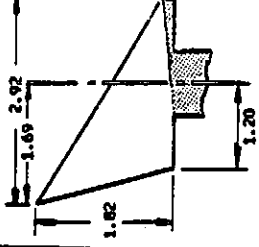
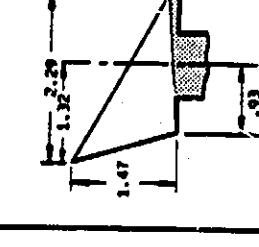
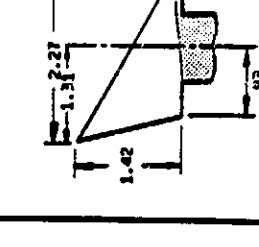
				
CONE AREA (m ²) EARTH IR (W)	8.76	8.03	5.26	4.88
	2.2	2.13	1.32	1.27
RADIATOR AREA (m ²) EARTH IR (W)	3.89	3.89	2.08	2.08
	.105	.114	.061	.066
FORWARD Baffle LENGTH (m) EARTH IR (W) RAD (W)	1.36	1.32	1.52	1.49
	.0186	.0171	.0203	.0137
	.0134	.0107	.0157	.0135
CONE TEMPERATURE (K) (ORBIT AVERAGE)	93.7	91.9	96.5	94.8

BOXED VALUES ARE TOTAL HEAT LOADS IN WATTS

SURFACE FINISH PROPERTIES OF VACUUM DEPOSITED ALUMINUM (VDA)

The surface properties shown in the accompanying table come primarily from report NAS5-24200. However, the values are representative of data identified in three other references^{1,2,3} for polished aluminum and vacuum deposited aluminum material at temperatures from 77K to 150K. In selecting what value to be used for the sunshade, various factors such as sunshade size, contamination potential, and possibility of eliminating design options by being too conservative all entered into the surface properties selected.

The following rationale was used for estimating the effect of contamination on the surface finish properties:

- Condensed molecular contamination on the low emissivity inner surface of the SIRTf sunshade will increase the emissivity of that surface.
- A 200 nm layer of H₂O would result in a relative increase in emissivity of 0.02. A similar increase would be caused by a 300 to 800 nm layer of organic contamination, the actual thickness depending on the particular contaminant.⁴ These numbers refer to absolute deltas in emissivity, regardless of substrate. (JPL modeling indicated less than 10 nm of H₂O was expected on the inner cone of the IRAS sunshade.⁵)
- These levels are considerably higher than one would expect to see if the appropriate attention is given to contamination control during the design and operation of the instrument.
- The three main sources of contamination for the SIRTf sunshade are:

Instrument outgassing
Shuttle thruster firings
On-board propulsion unit

All of these sources can be controlled by proper design and operational constraints, and therefore, the selected properties are considered realistic.

¹ Touloukian, Y., Dewitt, D., "Thermal Radiative Properties - Metallic Elements and Alloys", Thermophysical Properties of Matter, Volume 7, IFI/Plenum Data Corporation, 1980.

- 2 Ramanathan, K., Yen, S., Estalote, E., "Total Hemispherical Emissivities of Copper, Aluminum, and Silver", *Applied Optics*, Volume 16, No. 11, pg. 2815, November 1977.
- 3 Guilietti, D., Lucchesi, M., "Emissivity And Absorptivity Measurements On Some High-Purity Metals at Low Temperatures", *Applied Physics*, Volume 14, pg. 879, May 1981.
- 4 Viehmann, W. and Eubanks, A. "Effects of Surface Contamination on the Infrared Emissivity and Visible-light Scattering of Highly Reflective Surfaces at Cryogenic Temperatures" NASA TN D-6585, 1972.
- 5 Andreozzi, L., Irace, W., and Magg, C. "Contamination Control of the Infrared Astronomical Satellite", SPIE publication, Feb. 1981.

SURFACE FINISH PROPERTIES OF VACUUM DEPOSITED ALUMINUM (VDA)

	HEMISPHERE EMITTANCE		IR DIFFUSENESS			
	WORST	NOMINAL	BEST	WORST	NOMINAL	BEST
VDA AT 283K	0.040	0.035	0.030	0.010	0.007	0.003
VDA AT 153K	0.025	0.017	0.013	0.010	0.007	0.003

	SOLAR ABSORPTANCE		SOLAR DIFFUSENESS			
	WORST	NOMINAL	BEST	WORST	NOMINAL	BEST
VDA AT 283K	0.150	0.120	0.100	0.050	0.020	0.010
VDA AT 153K	0.150	0.100	0.080	0.030	0.020	0.010

BOXED VALUES WERE USED FOR REFERENCE CONFIGURATION

FOREBAFFLE TEMPERATURE AS A FUNCTION OF SURFACE FINISH

Here nominal and worst-case surface finish data for the cone VDA are compared.

The increase in forebaffle temperature is caused by several factors. First, an increase in radiation coupling between the sunshade and forebaffle due to an increase in sunshade emittance. Second, an increase in α_s which raises the average sunshade temperature. Third, an increase in diffuseness, which increases the scattered radiation onto the forebaffle.

All temperatures are for a 93 cm, partially illuminated radiator. The sun is in the orbit plane, and the assumed viewing scenario is shown on the following pages. Enough orbits have been run in each case to establish an orbital "steady state" in which the temperatures recur on each orbit.

NOTES:

- (1) Similar to properties and data used in NASA/ARC analysis.
- (2) Sunshade temperature is less than 153K for all cases.

FOREBAFFLE TEMPERATURE AS A FUNCTION OF SURFACE FINISH

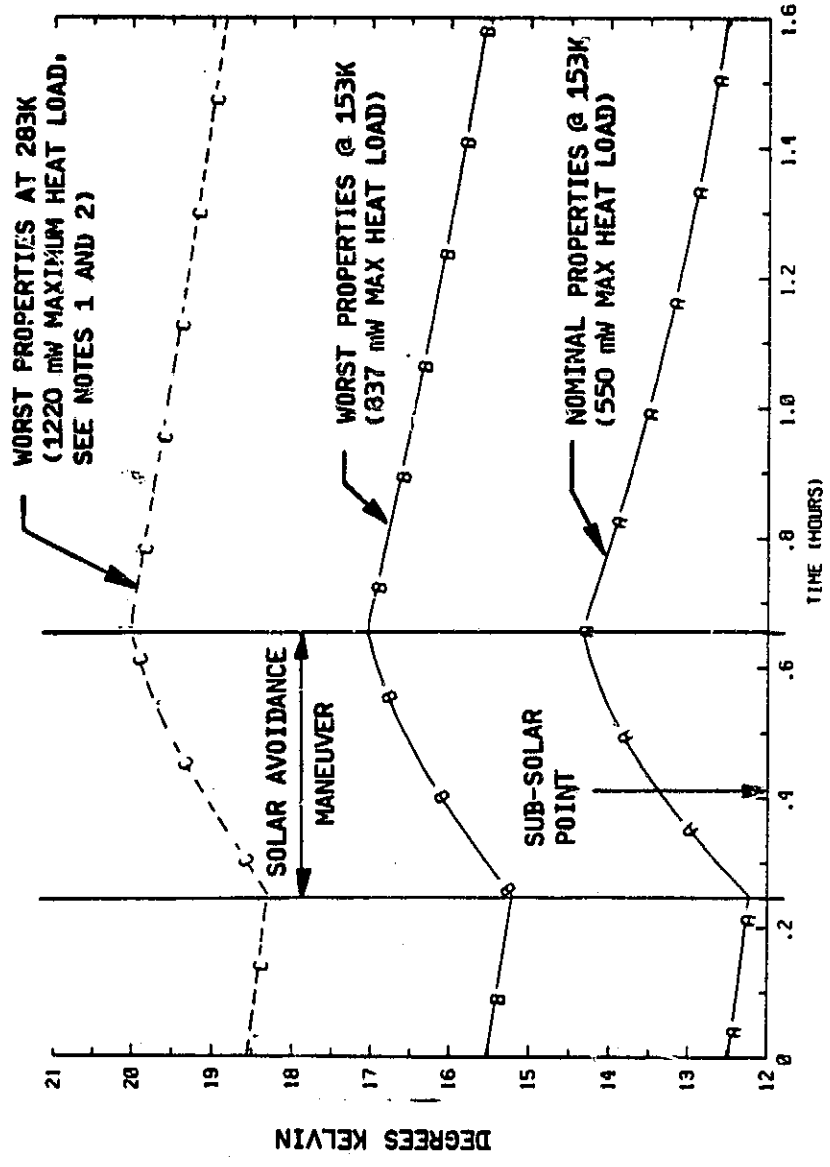

ALL TEMPERATURES ARE FOR REFERENCE CONFIGURATION

EARTH AVOIDANCE ANGLES

The timeline on the facing page was used for the transient analysis of the sun shade and the forebaffle for the case when the sun is the orbital plane.

In that part of the orbit from $\alpha = 60^\circ$ to $\alpha = 150^\circ$ we have taken the cone to be tipped over toward earth as far as is allowed. Over the rest of the orbit, it is assumed that no earthshine, albedo, or solar are absorbed by the inside of the cone, the radiator, or the forebaffle (zenith-looking). This timeline includes the "no upwind viewing" constraint. The performance of the sunshade and forebaffle under other viewing scenarios is addressed later in this report.

EARTH AVOIDANCE ANGLES (28.5° ORBIT)

--- USED FOR THERMAL ANALYSIS

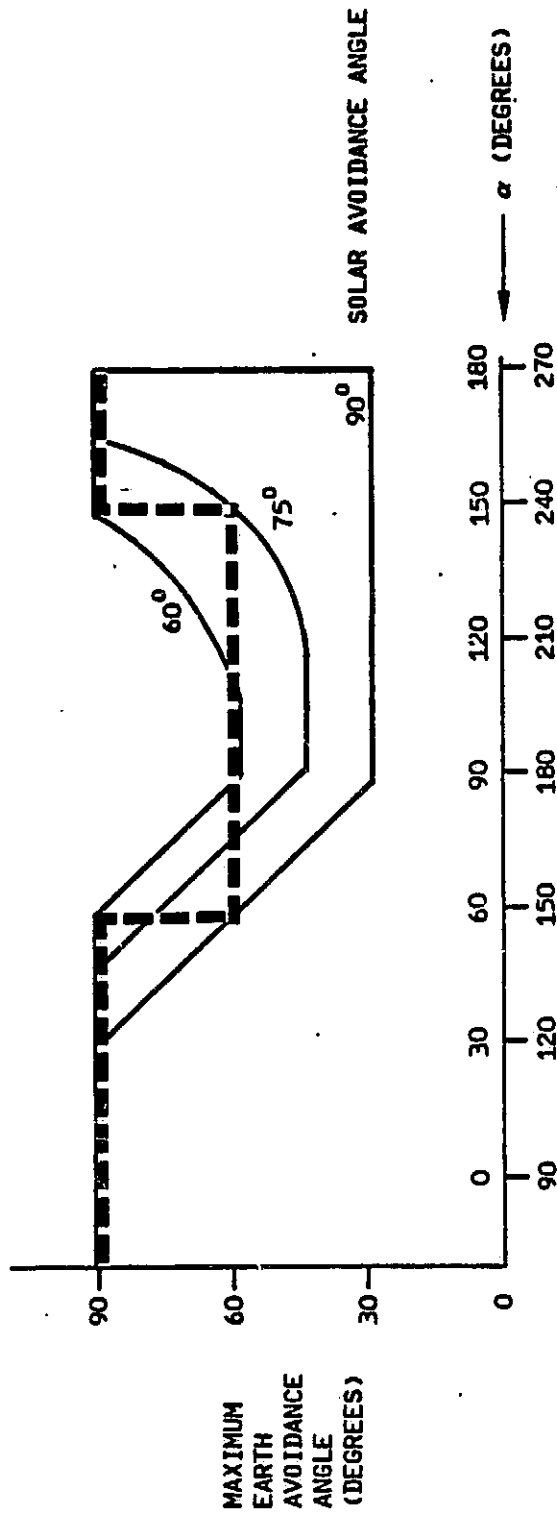

ORBITAL LONGITUDE (DEGREES)

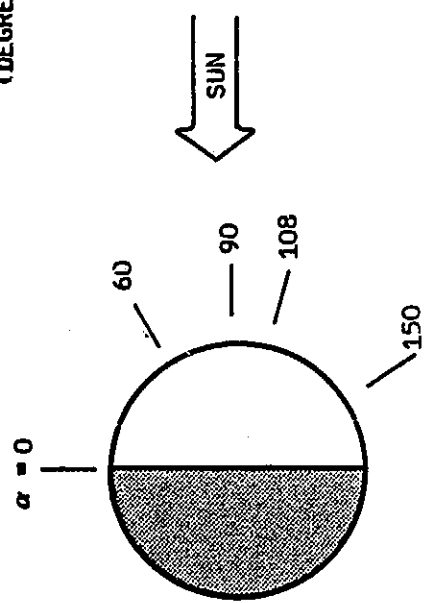

PEAK FOREBAFFLE TEMPERATURE AS A FUNCTION OF SUNSHADE FINISH PROPERTIES

The peak temperature experienced by the forebaffle during the solar avoidance maneuver in the 28.5° orbit is a strong function of hemispherical emittance. The plot on the facing page shows the forebaffle peak temperature as a function of hemispherical emittance for both the reference configuration (forebaffle attached to IVCS) and colder forebaffle configuration (forebaffle attached to aft baffle). The heat rate associated with the various emittances include scattered earth IR, albedo and sunshade IR absorbed by the forebaffle.

In the analysis conducted to generate these plots, the sunshade never rose above 153K. For this reason it is anticipated that for the SIRT mission, the sunshade hemispherical emittance will be between the nominal and worst values of 0.017 and 0.025.

PEAK FOREBAFFLE TEMPERATURE (AT SOLAR AVOIDANCE) AS A FUNCTION OF SUNSHADE SURFACE FINISH PROPERTIES

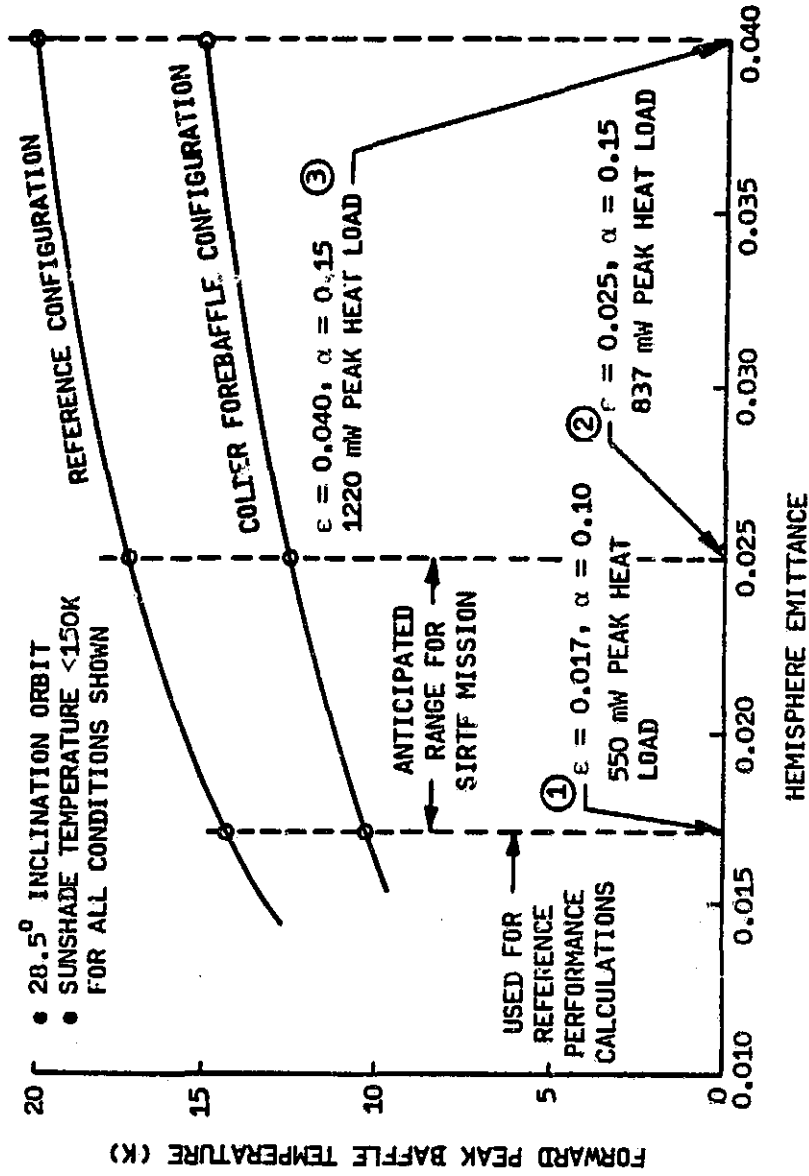

- ① VITA NOMINAL PROPERTIES AT 153K
- ② VITA WORST PROPERTIES AT 153K
- ③ VITA WORST PROPERTIES AT 283K

SUMMARY OF SUNSHADE RESULTS

The conclusions appearing on the opposite page are for the 28.5° inclination orbit. For the 98° inclination orbit, we still recommend the partially shadowed 93 cm radiator, but the choice is made on the basis of pointing considerations, since there is little difference in the forebaffle heat loads.

SUMMARY OF SUNSHADE RESULTS

- A FULL CONE GIVES UNACCEPTABLY HIGH HEAT LOADS TO THE FORE-BAFFLE
- A TRUNCATED IRAS-STYLE CONE WILL WORK FOR BOTH THE 28.5° AND THE 98° ORBITS
- ALLOWING THE RADIATOR TO BE PARTIALLY ILLUMINATED RESULTS IN A SMALLER HEAT LOAD TO FOREBAFFLE THAN THE FULLY-SHADOWED RADIATOR
- A 93 cm RADIATOR RESULTS IN A SMALLER HEAT LOAD TO THE FORE-BAFFLE THAN A 120 cm RADIATOR
- WITH A TRUNCATED CONE, MAXIMUM INSTANTANEOUS FOREBAFFLE HEAT LOADS DO NOT EXCEED 550 mW IN THE 28.5° ORBIT AND 32 mW IN THE 98° ORBIT

SECTION 5.0

SUPERFLUID HELIUM

CRYOGEN SYSTEM THERMAL ANALYSIS

PRECEDING PAGE BLANK NOT FILMED

SUPERFLUID HELIUM CRYOGEN SYSTEM THERMAL ANALYSIS

This section first presents a brief description of the major dewar configurations considered in this study. Presented next is a description of the thermal math model used for the majority of the cryogenic thermal analysis. It includes a description of the heat flow paths and aperture heating assumptions. Next, the thermal performance of the "reference configuration" is presented. This configuration is not to be considered the final recommended design. It is not an optimized configuration. It is a point design to which the various sensitivity analyses are compared. Data is also provided illustrating the effect of interface thermal resistance, the design driver, on secondary mirror cool down. A performance comparison of the 8800 and 4000 liter dewar systems is included. Thermal analysis conclusions ends this section.

SUPERFLUID HELIUM CRYOGEN SYSTEM THERMAL ANALYSIS

- **THERMAL ANALYSIS OVERVIEW**
- **THERMAL MATH MODEL**
- **REFERENCE CONFIGURATION SYSTEM PERFORMANCE**
- **SENSITIVITY ANALYSES**
- **SECONDARY MIRROR COOLDOWN**
- **8800 AND 4000 LITER DEWAR COMPARISON**
- **CONFIGURATION OPTIMIZATION**
- **THERMAL ANALYSIS SUMMARY AND CONCLUSIONS**

SECTION 5.1

THERMAL ANALYSIS OVERVIEW

PRECEDING PAGE BLANK NOT FILMED

FIVE PRINCIPAL CONFIGURATIONS EXPLORED

The five different cryogenic configurations explored in some detail are described here. The 8800 liter superfluid helium reference configuration was developed early in the study and then used as the baseline for analyzing the sensitivity of the system to various design and operational parameters. Three additional all-superfluid helium configurations were examined to evaluate the impact of designing either very long life, very low forebaffle temperature, or smaller overall size. For comparison, a dual-cryogen system using solid hydrogen in addition to superfluid helium was also evaluated.

The very-long-life configuration differs from the reference configuration in using 4 vapor-cooled shields instead of 3 to reduce parasitic heat load on the superfluid helium tank.

To reduce the temperature of the telescope forebaffle, the option of attaching the forebaffle to the aft baffle instead of the inner vapor-cooled shield was explored. In both cases the primary cooling of the forebaffle is with a gaseous heat exchanger. The thermal isolator between the baffle and its supporting structure is assumed to have a thermal conductance of 10 mW/K; preliminary structural analysis indicates that this is realistic.

To reduce the overall system size, the option of using 4000 liters of helium tank was explored. The support straps were resized to match the reduced supported mass, and the envelope area was reduced.

For comparison, we explored a dual-cryogen system that uses solid hydrogen to cool the forebaffle and a shroud surrounding the superfluid helium tank. The hydrogen tank was sized to provide 25 percent lifetime margin over the helium to ensure that it will not run out before the helium.

It is to be emphasized that throughout this report, references to "lifetime" always include margin, i.e., if the stated lifetime value is 2.7 years, this is equivalent to a 2.0 year mission with a 33% margin.

FIVE PRINCIPAL CONFIGURATIONS EXPLORED

	REFERENCE CONFIGURATION ¹	ALTERNATE CONFIGURATIONS			
		VERY LONG LIFE	COLDER FORE-BAFFLE	SMALLER DEWAR	DUAL CRYOGEN
CRYOGEN(S) (LITERS): <ul style="list-style-type: none"> • SUPERFLUID HELIUM • SOLID HYDROGEN 	8800	8800	4000	4000	4000
	---	---	---	---	890
HEAT SHIELDS: <ul style="list-style-type: none"> • HELIUM VAPOR COOLED • HYDROGEN CONDUCTION COOLED 	3	3	3	3	3
	---	---	---	---	1
FOREBAFFLE MOUNTING	IVCS ²	IVCS	AFT BAFFLE	IVCS	HYDROGEN TANK

1. USED FOR SENSITIVITY ANALYSIS
2. INNER VAPOR-COOLED SHIELD

SECTION 5.2

THERMAL MATH MODEL

PRECEDING PAGE BLANK NOT FILMED

REFERENCE CONFIGURATION MODEL FOR STUDY

This all-superfluid system has been refined so as to maximize the vapor cooling to permit a long dewar life.

While the reference configuration is an 8800 liter SHe dewar so as to take advantage of the Shuttle volume capability, a 4000 liter dewar has also been analyzed and the data included.

An area of concern at mid-term was the forward baffle peak temperature, experienced during a small portion of the 28.5° inclination orbit. Since that time, considerable effort has been expended on the sunshade design, refrigeration efficiencies and mounting schemes. As a result, forward baffle peak temperature is now less than 15K for the reference configuration, and less than 11K for the colder forward baffle configuration.

The MIC 7K instrument heat sink station design can have considerable system impact when coupled with the internal thermal design of the instruments. Data on this interface is provided to show how to minimize this impact.

REFERENCE CONFIGURATION MODEL FOR STUDY

	REFERENCE CONFIGURATION	SMALL DEWAR
● VOLUME	8800 LITER	4000 LITER
● DIAMETER	285 cm	240 cm
● LENGTH	600 cm	560 cm
● STRAPS:		
- AREA	36.8 cm ²	23.2 cm ²
- LENGTH	77 cm	80 cm
● VAPOR COOLED SHIELDS	3	3
● ELECTRICAL DISSIPATION:		
- COLD MIC		50 mW
- HOT MIC		150 mW
- CHOPPER MOTOR		30 mW
- FGS		50 mW
● APERTURE HEAT LOAD		
(28.5° INCLINATION):		
- MISSION AVERAGE		83 mW
- PEAK (SUN AVOIDANCE)		550 mW
- STARING MODE		43 mW

THERMAL MATH MODEL OVERVIEW

The thermal math model is comprised of about 35 nodes, 65 linear paths and 20 radiation paths. The outer shell (OS), OVCS, and MVCS are divided into 4 nodes each. The IVCS is one node.

The radiation coupling from the sunshade to the forward baffle was determined by means of a BASD developed Monte Carlo program capable of modeling truncated cones. The forward baffle is mounted to the IVCS by means of thermal isolating fiberglass Z sections. This permits easy installation and long life. As a configurational trade off, a case where the forward baffle mounted to the aft baffle was investigated. While installation could be difficult and life time is somewhat degraded, forward baffle temperature can be reduced. Details of this trade-off are presented later.

Three instruments were assumed for the baseline model. This has no effect on the MIC cold station design, but can have considerable effect on the MIC hot station. Intrinsic to each instrument is a thermal path from its hot station to the cold station. This "sneak path" is a thermal conductor even when the instrument is off. Therefore the internal design of each instrument and the number of instruments is a strong driver on system performance. The three sneak paths are modeled with one linear path (321) and the hot station isolation from the baseplate is modeled with a linear path (322).

The FGS which requires a temperature of approximately 100K can be mounted externally with a very small light path penetrating the assembly. This imposes virtually no additional heat load on the MCT. However, for the reference configuration, the FGS is mounted internally. It is isolated from the baseplate by a fiberglass tube. It rejects its heat to the OVCS by means of a mate/demate finger. This configuration imposes a 8 mW load on the MCT.

The modeling of the MLI used a radiation/conductivity curve fit of:

$$K = 16.9 \times 10^{-12} (T_1^2 + T_2^2) (T_1 + T_2) + 1.6 \times 10^{-6} \text{ mW/cm-K.}$$

Thermal conductivity data for the supports was taken from:

"Thermal conductivity of Glass Fiber/Epoxy Composite Support Bands for Cryogenic Dewars, Phase II", June 1983, J.G. Host, NBS.

SIRTF THERMAL MATH MODEL OVERVIEW

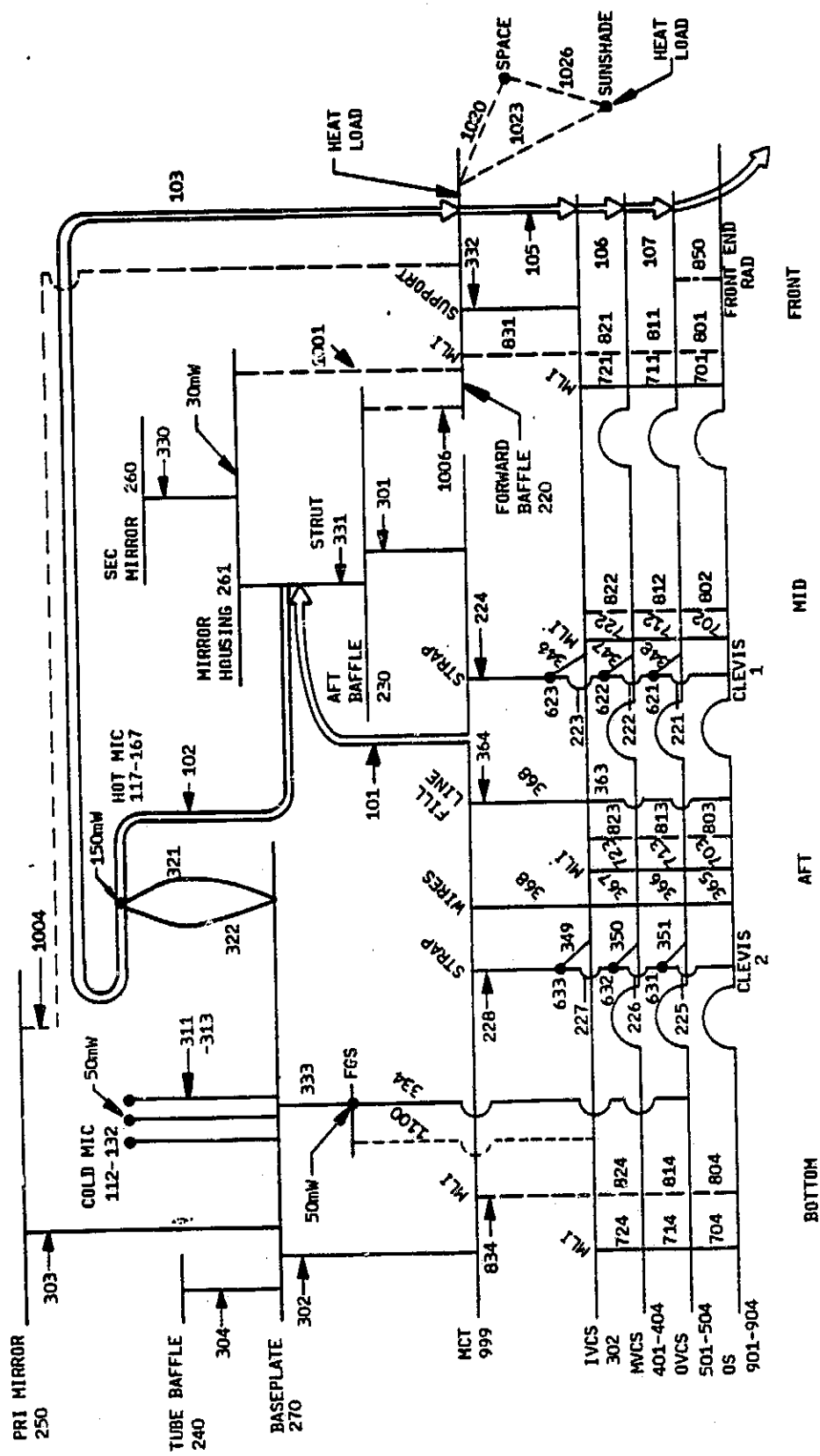

— CONDUCTION
 - - - RADIATION
 == EFFLUENT GHe FLOW

ASSUMED 28.5° INCLINATION TIMELINE FOR MODELING PURPOSES

Early in the study it was thought that aperture heating was the key design driver in the 28.5° inclination mission. However, with the appropriate sunshade design, aperture heating is not a serious design driver.

28.5° inclination orbit was chosen as the reference mission for this study. During a typical 26-day period slightly over five days were assumed to be at or near $\text{Beta} = 0^\circ$. This drives the telescope into a sun avoidance maneuver once an orbit. During the remainder of the 26 days the telescope was assumed to be in the staring mode with no sun, earth IR or albedo heat loads on the aperture, with sunshade temperature only a function of sunshade wall heat leak. While these assumptions are only one of a set of possibilities, they turn out not to be strong drivers of system performance. The duration of the avoidance maneuver and the occasional aperture heating which could occur in the staring mode will change the 83 mW assumed for mission average aperture heating. However, this 83 mW assumption will be shown not to be critical to mission life.

ASSUMED 28.5° INCLINATION TIMELINE FOR MODELING PURPOSES

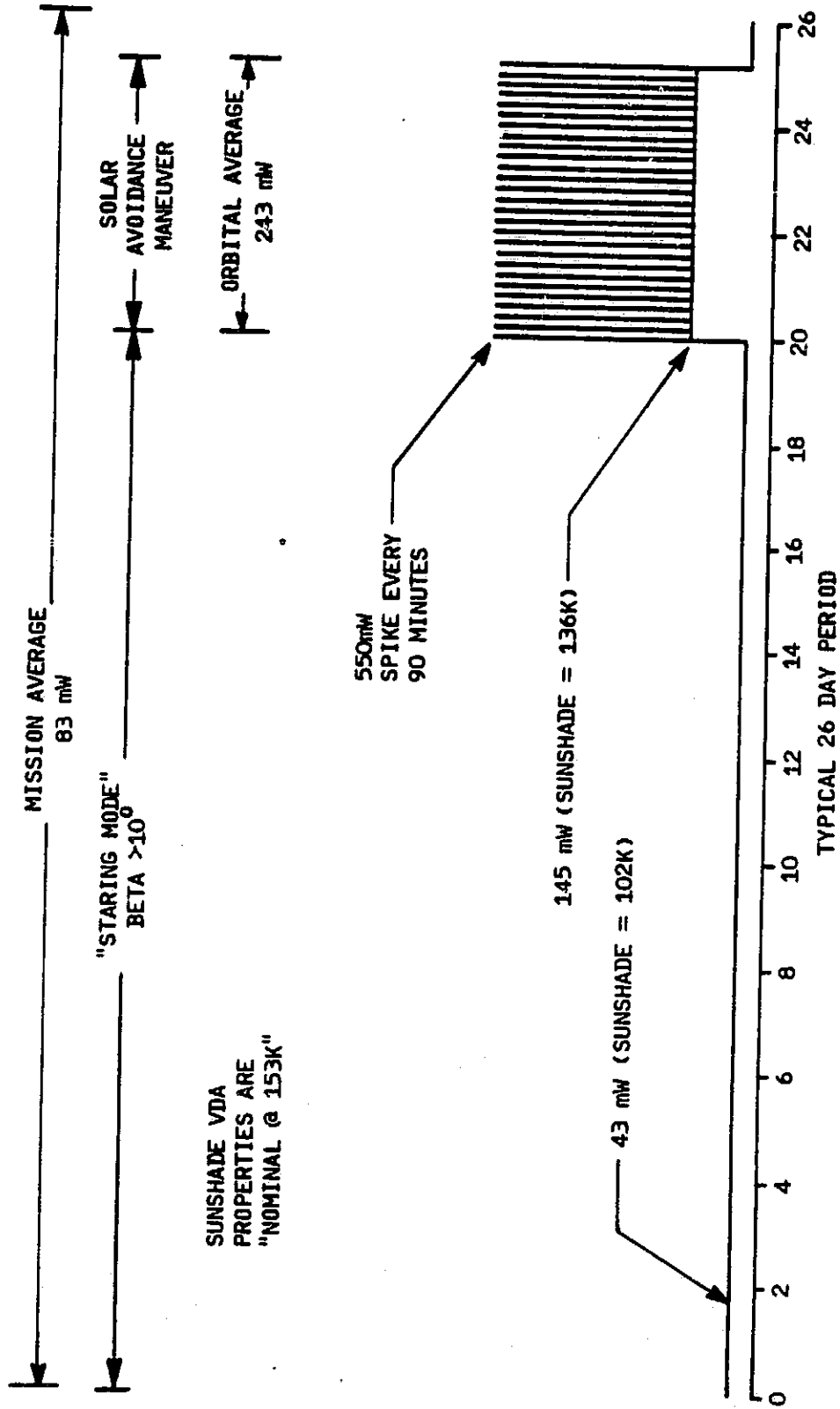

EFFECT OF STARING MODE VIEWING ASSUMPTIONS

As was stated earlier, the assumption of no scattered earth IR and albedo aperture heating during the staring mode is one possibility. It is reasonable because views toward the earth limb would not be an appreciable portion of the staring mode.

In order to demonstrate that life is highly decoupled from aperture heating, lets assume that for the entire mission the orbit plane is at or near the sun line (Beta = 0°). This is not a realistic assumption for SIRIF but is used for the purpose of illustration. In this worst case the orbital average aperture heating is 243 mW. This can be used for life calculation to obtain a life of 4.49 years.

Thus, even a totally unrealistic viewing scenario for the survey mode reduces life no more than 0.27 years.

EFFECT OF STARING MODE VIEWING ASSUMPTIONS ON LIFE AND FORWARD BAFFLE TEMPERATURE

- ASSUME ENTIRE MISSION IS AT BETA = 0 100% OF TIME*
- ORBITAL AVERAGE HEATING = MISSION AVERAGE HEATING = 243 mW
- LIFE IS DEGRADED BY ONLY 4%
- FOR ANY LIKELY SCENARIO
 - FORWARD BAFFLE TEMPERATURE IS ALWAYS BETWEEN 9.8K AND 14.5K
 - LIFE OF APPROXIMATELY 4.5 YEARS CAN BE EXPECTED

	APERTURE HEAT (STARING MODE) (mW)	APERTURE HEAT (MISSION AVG) (mW)	LIFE (YEARS)	FORWARD BAFFLE TEMPERATURE (STARING MODE) (k)
EARTH AVOIDANCE > 57° (REFERENCE)	43	83	4.66	9.8
EARTH AVOIDANCE = 57° 100% OF TIME	243	243	4.49	12 TO 14.5

*THIS IS NOT A REALISTIC ASSUMPTION FOR SIRTf BUT IS USED FOR PURPOSE OF ILLUSTRATION

APERTURE HEATING BY SCATTERED RADIATION FOR THE 28.5° ORBIT

The facing chart illustrates the shape of the aperture heat pulse for the reference case. This pulse lasts for 25 percent of the orbit when $\beta \sim 0^\circ$ and corresponds to the maneuver discussed in a previous section. This aperture pulse peaks at 405 mW and is then added to the 145 mW heat load due to IR emission from the sunshade.

The 550 mW (405 mW + 145 mW) peak aperture heating during the sun avoidance maneuver determines the baffle peak temperature. The 83 mW is the average aperture heating for the entire mission and determines mission life.

APERTURE HEATING BY SCATTERED RADIATION FOR THE 28.5° INCLINATION ORBIT (SUN AVOIDANCE MANEUVER, BETA = 0)

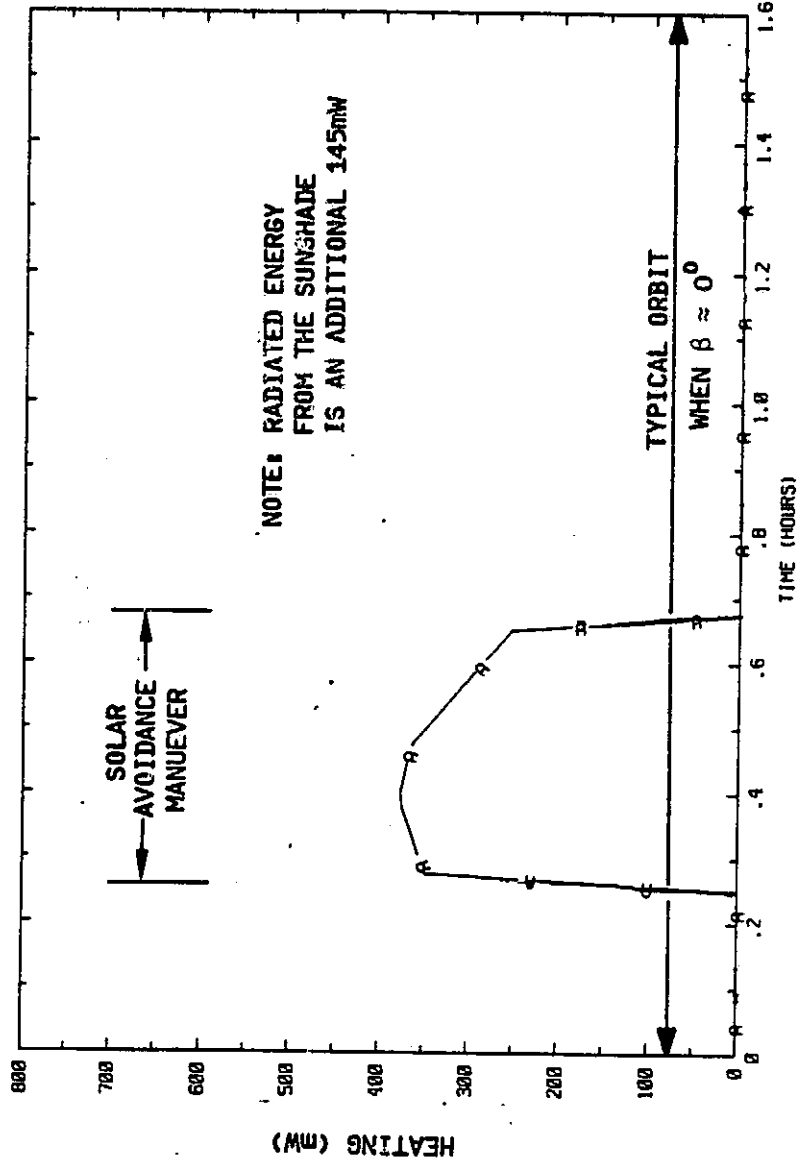

SECTION 5.3
REFERENCE CONFIGURATION
SYSTEM PERFORMANCE

PRECEDING PAGE BLANK NOT FILMED

MAJOR MAIN CRYOGEN TANK (MCT) HEAT LOADS FOR THE REFERENCE CONFIGURATION

83 mW aperture heating was used in the reference case life estimate of 4.66 years. Since the forward baffle is not directly coupled to the MCT, forward baffle heating shows up only as a small increase in parasitic heat loads, and is therefore not a strong driver of system life. The forward baffle is less than 9.8°K during 80 percent of the mission. It varies between 12° and 14.5°K once each orbit during the other 20 percent when 8--0°.

Straps which account for 29 percent of the MCT load are overshadowed by the instruments which contribute 46 percent of the total load. Of this 46 percent, 21 percent is due to the instruments' internal thermal paths from the hot to cold stations. This will be discussed in detail later.

The FGS dissipates 50 mW but only nine mW leaks into the tank. The rest is absorbed by the OVCS.

A key is that for either the 28.5° or the 98° mission the same dewar can be used, only the sunshade must be changed.

MAJOR MCT HEAT LOADS FOR THE REFERENCE CONFIGURATION

STRAPS	29%
WIRES	6%
MLI	10%
CHOPPER MOTOR	4%
HOT INSTRUMENT STATION	21%
COLD INSTRUMENT STATION	25%
FGS	5%

REFERENCE CONFIGURATION HEAT FLOWS

The following chart is a simplified heat flow summary of the configuration. The table at the bottom is the heat flows through each path in the thermal model. The path numbers referenced are those depicted in the "SIRTF THERMAL MODEL OVERVIEW" chart.

The vertical lines on the chart represent nodes. The horizontal lines represent the major heat flow paths. The double horizontal line represents the gaseous effluent flow. All units are (m²) unless otherwise noted.

REFERENCE CONFIGURATION HEAT FLOWS, MISSION AVERAGE 83mW ON FORWARD BAFFLE

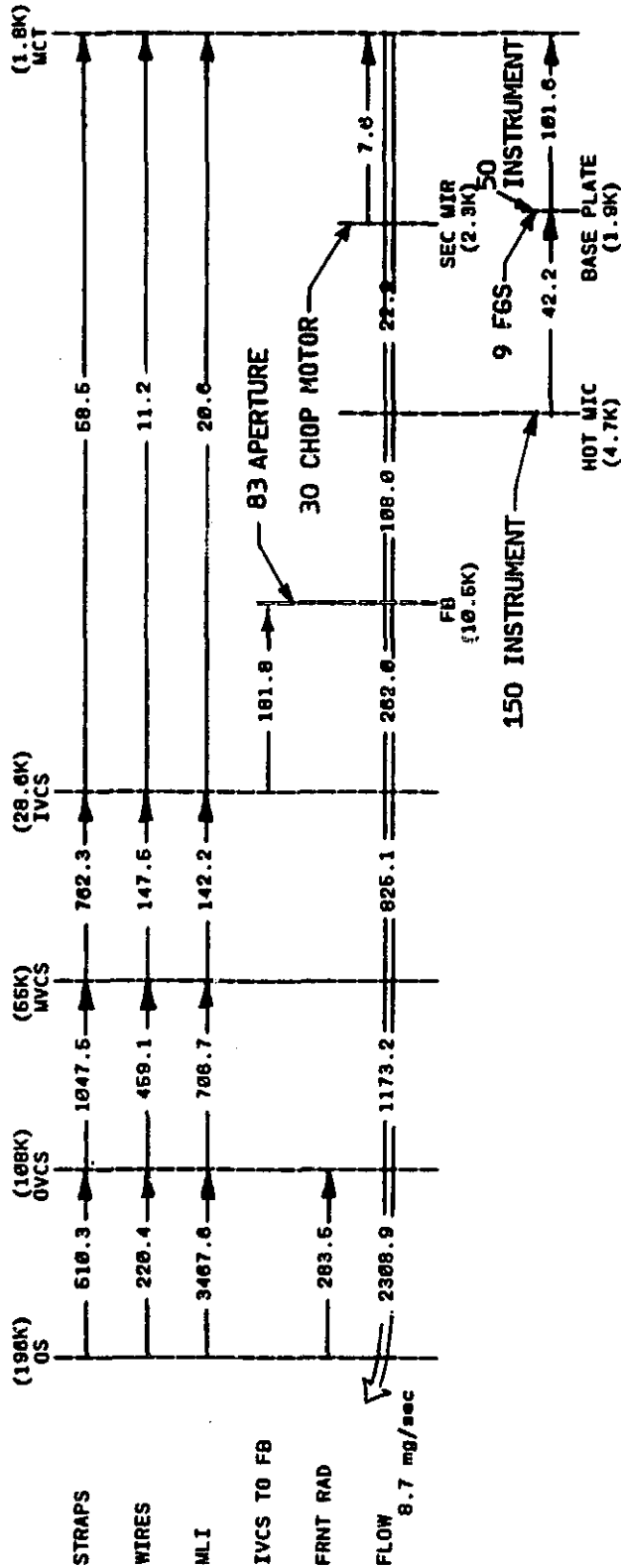

(DETAILED HEAT FLOWS THROUGH EACH CONDUCTOR)

QF 101=2.29459E+01	QF 102=1.07761E+02	QF 103=2.62412E+02	QF 105=8.25104E+02
QF 219=2.54247E+02	QF 221=2.56034E+02	QF 222=5.19644E+02	QF 223=3.79249E+02
QF 304=2.38419E-03	QF 311=5.00120E+01	QF 312=1.19299E-02	QF 313=1.19208E-02
QF 330=0.83089E-08	QF 331=7.05388E+00	QF 332=1.81780E+02	QF 333=9.27319E+00
QF 347=1.41384E+02	QF 348=3.49040E+02	QF 349=2.73598E+02	QF 350=1.43912E+02
QF 364=7.16593E-02	QF 365=2.20423E+02	QF 366=4.59288E+02	QF 367=1.47531E+02
QF 505=3.87379E+02	QF 508=0.37491E+01	QF 507=1.48553E+03	QF 509=3.24534E+02
QF 702=2.79248E+00	QF 703=2.75974E+00	QF 704=9.65672E-01	QF 711=3.00057E+00
QF 714=1.10286E+00	QF 721=2.00562E+00	QF 722=2.07196E+00	QF 723=2.09750E+00
QF 802=1.03439E+03	QF 803=1.03040E+03	QF 804=3.61898E+02	QF 811=1.97705E+02
QF 814=7.7824E+01	QF 821=4.01095E+01	QF 822=4.29051E+01	QF 823=1.51970E+01
QF 834=2.05879E+01	QF 860=2.03475E+02	QF 1001=0.22204E-04	QF 1004=1.22200E-04

>>> FLOW RATE=0.8729E-02 gm/sec ESTIMATED LIFE= 4.864 years <<<

NOTE: ALL UNITS ARE (mW) UNLESS OTHERWISE NOTED.

VAPOR COOLED SECONDARY MIRROR PERFORMANCE

Of the 30 mW chopper motor dissipation, only 7.6 mW is a direct load on the MCT. This is due to the vapor cooling of the support which is thermally isolated from the aft baffle. By this scheme, the secondary mirror and the chopper motor are always less than 2.5°K precluding the worry of BLINK on the secondary mirror from chopper motor pulsations. (See A.J. Mord in Cryogenic Optical Systems and Instruments, R.K. Melugin, ed., Proc. SPIE 509, in press).

VAPOR COOLED SECONDARY MIRROR PERFORMANCE (28.5° ORBIT, SUN AVOIDANCE MANEUVER)

- AT 3K AND 200 μm MIRROR STABILITY REQUIREMENT IS $\Delta T < 0.96K$
- PREDICTED ΔT IS 0.01K
- REFERENCE DESIGN IS VAPOR COOLED AND NOT COUPLED TO FORWARD BAFFLE

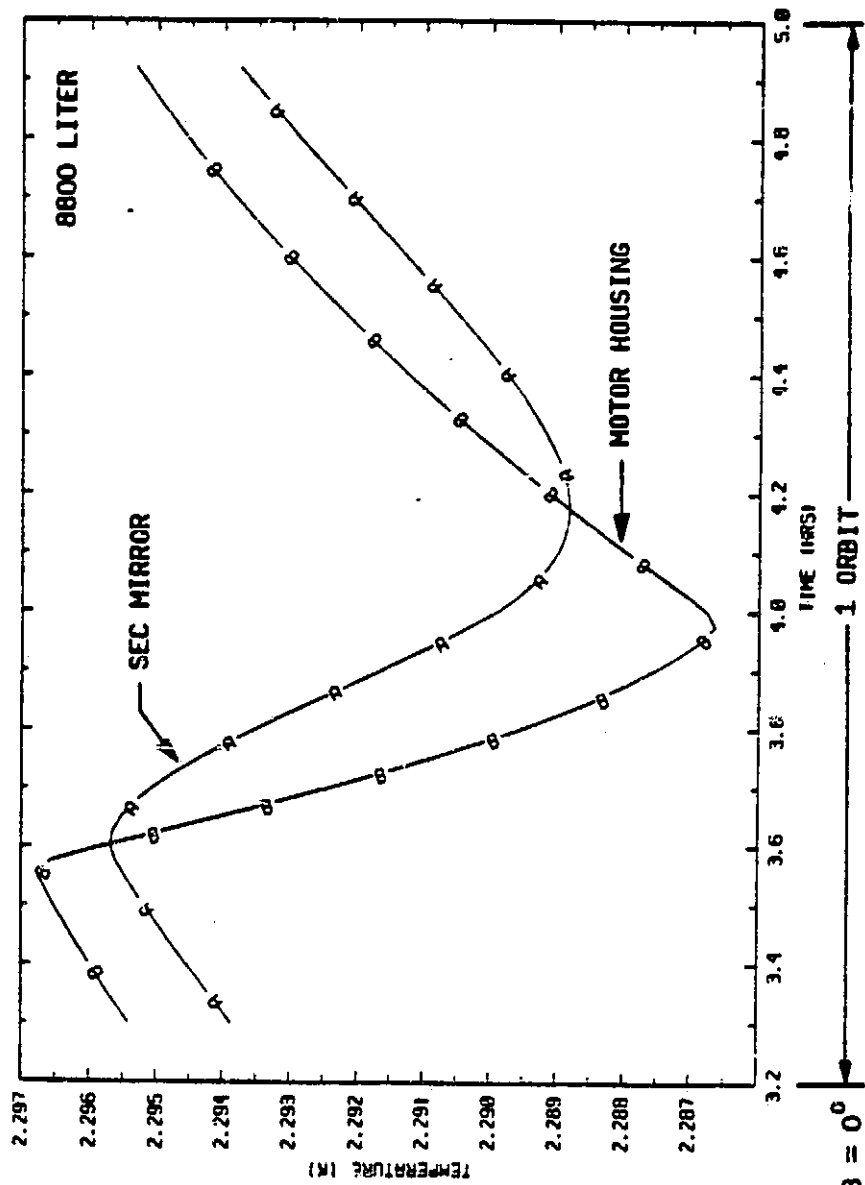

EFFECT OF CHANGING INSTRUMENT POWER DISSIPATION ON MIC THERMAL STABILITY

While the nominal power dissipated at the MIC 2K station is 50 mW, peaks of 150 mW were investigated. As power dissipated at the 2K station increases from 50 to 150 mW the 2K station temperature rises only 0.2K. This is due to a good thermal joint between it and the baseplate. As this heat soaks back to the cryogen tank the He flow rate increases causing the 7K station temperature to drop about 1K. This is caused by the vapor cooling of the 7K station, which is its primary means of temperature control.

EFFECT OF CHANGING INSTRUMENT POWER DISSIPATION ON MIC THERMAL STABILITY (28.5° ORBIT, AT SOLAR AVOIDANCE)

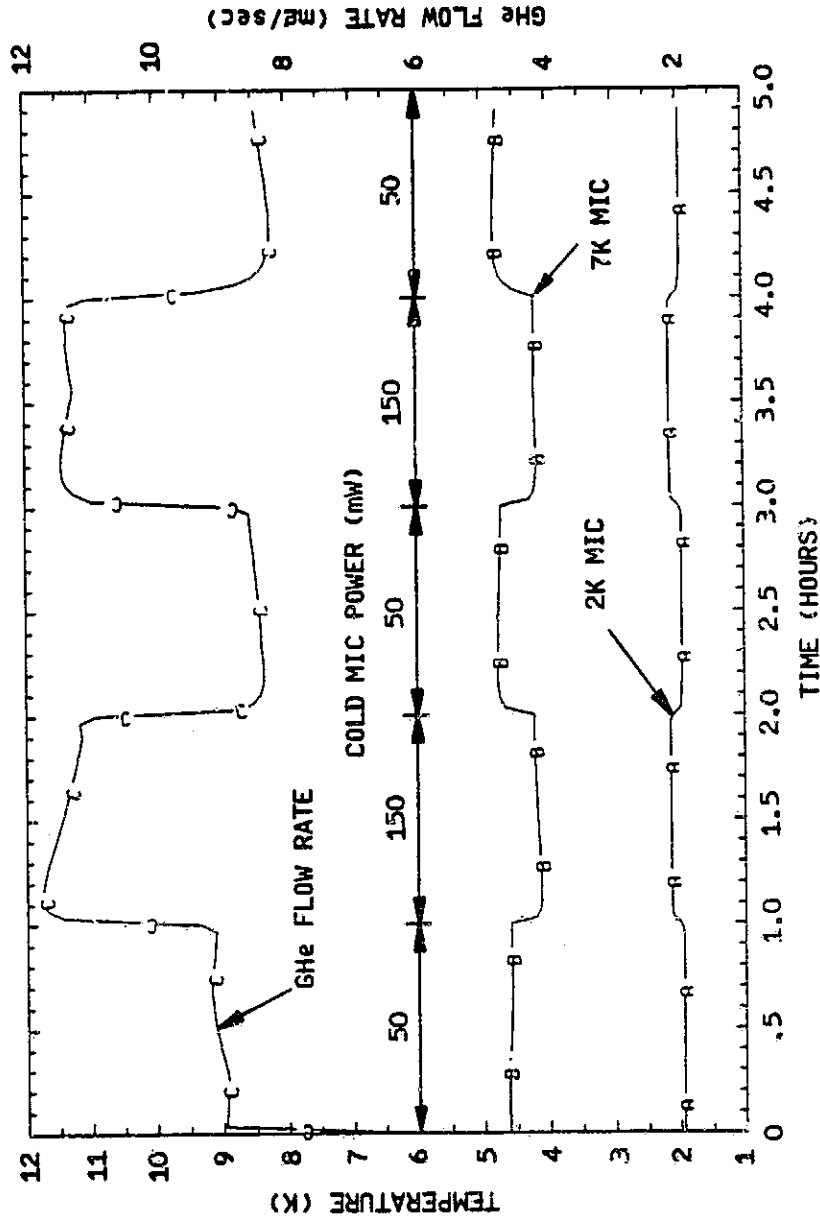

NOTE: THIS DATA IS BASED ON THE "REFERENCE CONFIGURATION"

A SINGLE 7K STATION PROVIDING COOLING FOR ALL INSTRUMENTS IS PREFERRED

The instrument 7K heat sink station design is interesting in that it, at first, seems very straightforward. However, it can be one of the more serious design drivers. There are two reasons for this. First is the internal design of the instrument which could conceivably provide a dead short between the 7K and 2K instrument stations. Second, undesirable temperature interaction between the instruments can be introduced, depending on the vapor cooling scheme employed for the 7K sinks.

Intrinsic to each instrument is a thermal path from the hot to the cold station. This path is independent of powered state of the instrument. The enclosed data illustrates that for only 3 instruments and a rather benign 5 mW/K sneak path, the hot station provides 21 percent of the entire MCT heat load. Until such a time as this "interface" is controlled to some lower value, it will remain as a large driver to system performance.

A SINGLE 7K STATION PROVIDING COOLING FOR ALL INSTRUMENTS IS PREFERRED

- INTERNAL THERMAL DESIGN OF THE INSTRUMENTS NEEDS CAREFUL INTERFACE CONTROL
- INDIVIDUAL COOLING OF INSTRUMENT 7K STATIONS INTRODUCES:
 - INSTRUMENT TEMPERATURE SENSITIVITY TO POSITIONAL LOCATION (RELATIVE TO POWERED INSTRUMENT)
 - LIFETIME SENSITIVITY TO POSITIONAL LOCATION
- INDIVIDUAL COOLING IS MORE DIFFICULT DUE TO VENT LINE LENGTH NEEDED FOR EFFICIENT VAPOR COOLING
- CUSTOMIZED LOCATIONS FOR EACH INSTRUMENT COULD BE PROVIDED

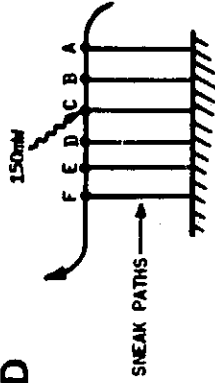
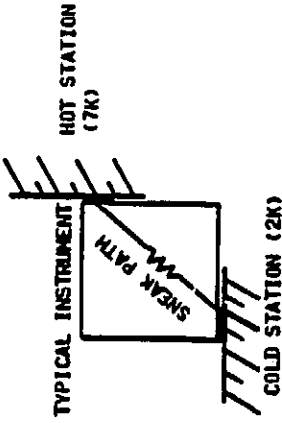

EFFECT OF 7K STATION DESIGN ON FLOW RATE AND 7K STATION TEMPERATURE

Another aspect of the hot station design is the manner of the vapor cooling. Early in the study we assumed that each instrument hot station would be cooled in turn. However, two problems arose. First, system life depends on which of the instruments is on. Second, instrument temperature depends on the order in which it is cooled and which instrument is on. This position sensitivity can be eliminated by providing one hot vapor cooled station to which each instrument is attached.

EFFECT OF 7K MIC STATION SNEAK PATHS ON EFFLUENT FLOW RATE

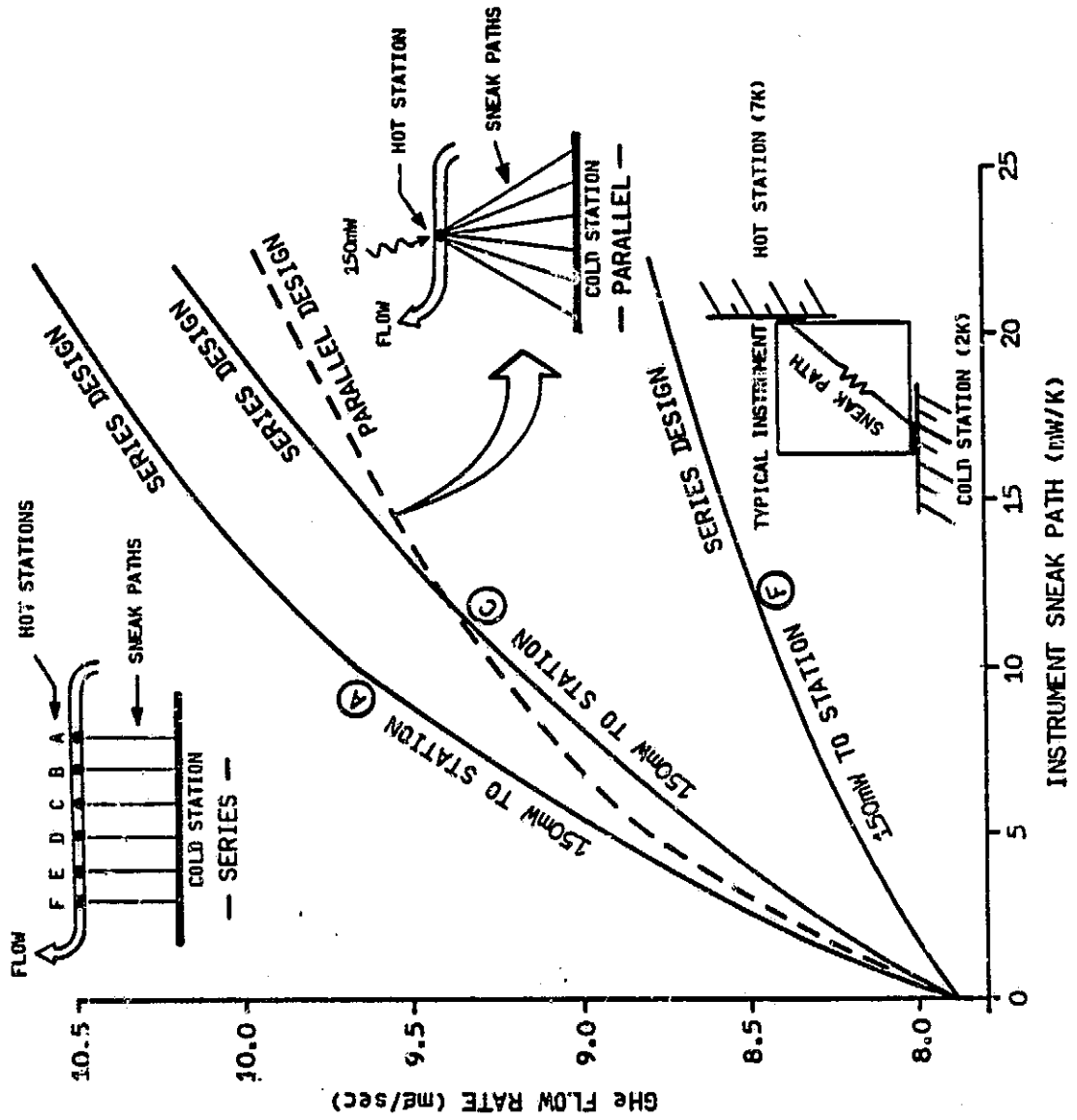

SERIES DESIGN IS POSITION SENSITIVE

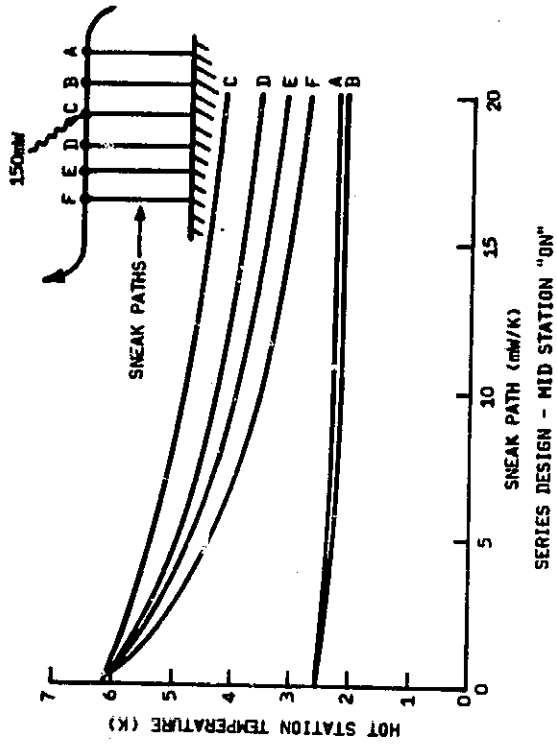
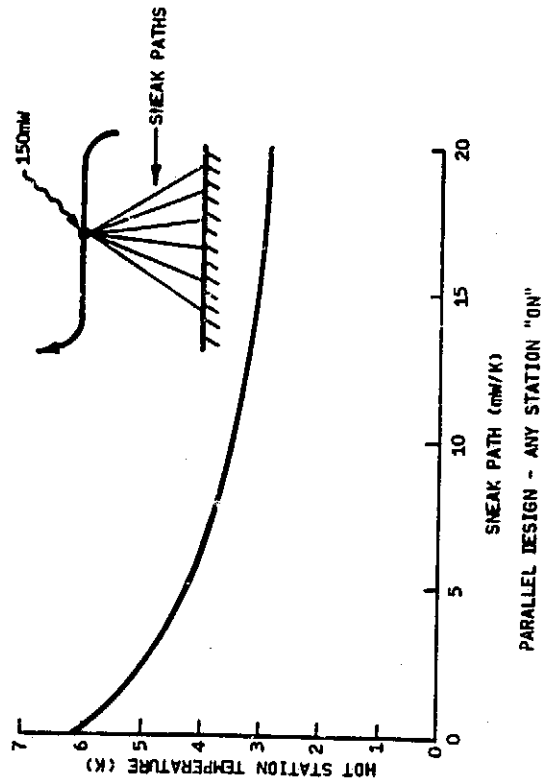

PRECEDING PAGE BLANK NOT FILMED

SECTION 5.4

SENSITIVITY ANALYSES

PRECEDING PAGE BLANK NOT FILMED

SENSITIVITY ANALYSES

Electrical dissipations, spacecraft configuration, mission operation and mechanical details will change from the values assumed in the reference configuration. In order to assess the importance of these elements to the telescope design, sensitivity analyses were conducted on key issues.

SENSITIVITY ANALYSES

- **APERTURE HEATING**
- **INSTRUMENT HEAT LOADS**
- **OUTER SHELL TEMPERATURE**
- **FOUR VAPOR COOLED SHIELDS**
- **SUPPORT DISCONNECT SYSTEM**
- **SECONDARY MIRROR MOUNTING**
- **FORWARD BAFFLE MOUNTING**

EFFECT OF APERTURE PEAK HEATING AND FORWARD BAFFLE PEAK TEMPERATURE

As was stated earlier, aperture peak heating determines forward baffle peak temperature, whereas mission average aperture heating determines mission life.

For the 28.5° inclination orbit, proper sunshade design can limit peak heating to 550 mW for 25 minutes once each orbit for that 20 percent of the mission at or near Beta = 0°.

The reason that the forward baffle temperature remains so low (14.5K for reference configuration and 10.5K for cold fore baffle configuration) is that the gaseous helium flow rate is high, 9.2 mg/sec and the cooling gas is at approximately 5K. IRAS flow rates were much lower (approximately 3 mg/sec).

THE EFFECT OF APERTURE PEAK HEATING ON FORWARD BAFFLE PEAK TEMPERATURE (28.5° ORBIT, AT SOLAR AVOIDANCE)

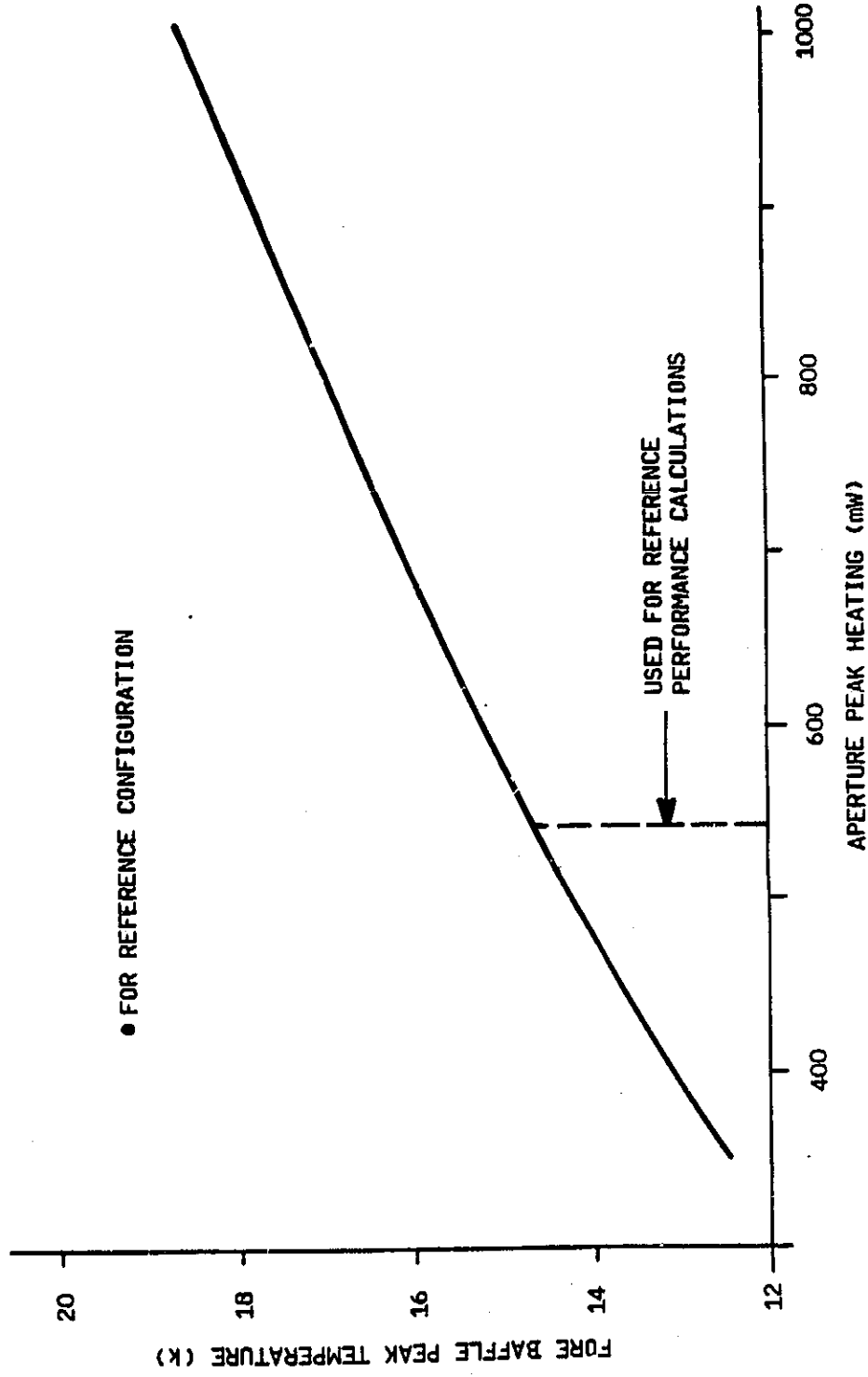

EFFECT OF "BEST" AND "WORST" THERMAL SCENARIOS ON FOREBAFFLE TEMPERATURES

The effect of different pointing scenarios during the $\beta = 0$ orbit is explored here. Realistic operating scenarios involving pointing at astronomical objects, slewing, and the solar-avoidance maneuver have not yet been developed, but the two scenarios shown here define the best- and worst-case bounds from a thermal point of view.

When the sun is in the orbit plane ($\beta = 0$), a solar-avoidance maneuver lasting about 20 minutes must be performed to prevent exceeding the sun- and earth-avoidance design limits of the sunshade. The total heat load on the forebaffle is minimized if the telescope is slewed (ideally instantaneously) to near zenith immediately after the avoidance maneuver. This best-case limit produces temperature swings between 12.3K and 14.3 with the reference cryogenic configuration.

The worst-case bound consists of pointing the telescope 58.9° above earth limb (the design limit of the sunshade) continuously. The infrared earth shine is constant, as shown, with a broad peak in the aperture heat load due to the reflected sunlight (albedo). In this worst case, the baffle temperature swings between 15.8K and 16.8K.

The temperature of the baffle can be reduced by mounting the forebaffle to the aft baffle through an isolator.

EFFECT OF "BEST" AND "WORST" THERMAL SCENARIOS ON FOREBAFFLE TEMPERATURE (SOLAR AVOIDANCE MANEUVER ($\beta = 0$), 28.5° ORBIT

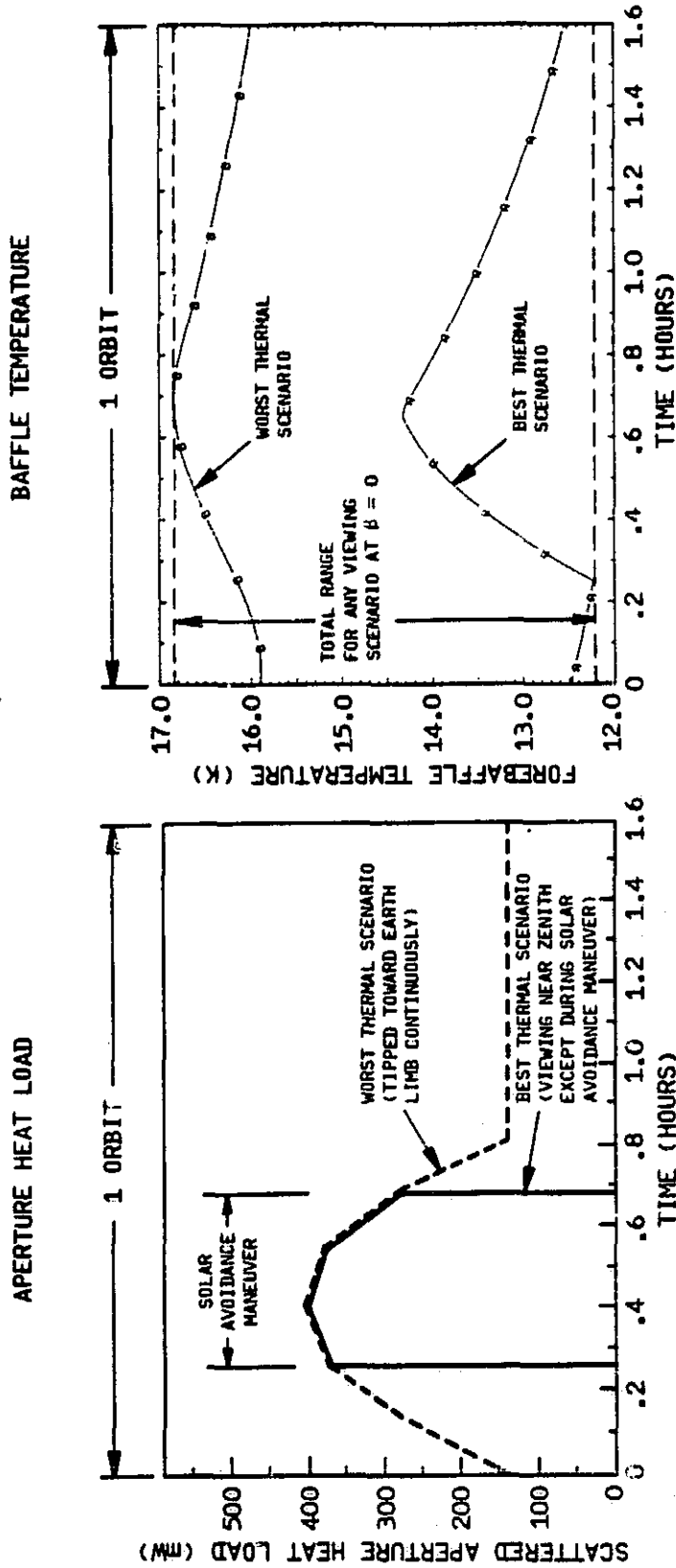

NOTES:

1. EARTH SHINE AND ALBEDO SCATTERED BY SUNSHADE. THERMAL RADIATION FROM SUNSHADE (145 mW BEST CASE, 177 mW WORST CASE) NOT SHOWN HERE, BUT INCLUDED IN CALCULATION.

0-2

APERTURE HEATING HAS SMALL EFFECT ON LIFETIME

Since the forward baffle is vapor cooled and is only attached to the IVCS through a fiberglass isolator, aperture heating becomes very decoupled from system life. Virtually all aperture heat is carried away by vapor cooling, with only 5 mW additional parasitic load on the MCT for every 100 mW of aperture heating. The reason the parasitics are increased only slightly is seen when the heat balance chart is examined. There is already a 1000 mW load on the IVCS. When this is increased by 100 mW from the forward baffle the IVCS temperature increases approximately 1K with only a slight increase in the parasitics.

APERTURE HEATING HAS SMALL EFFECT ON LIFETIME

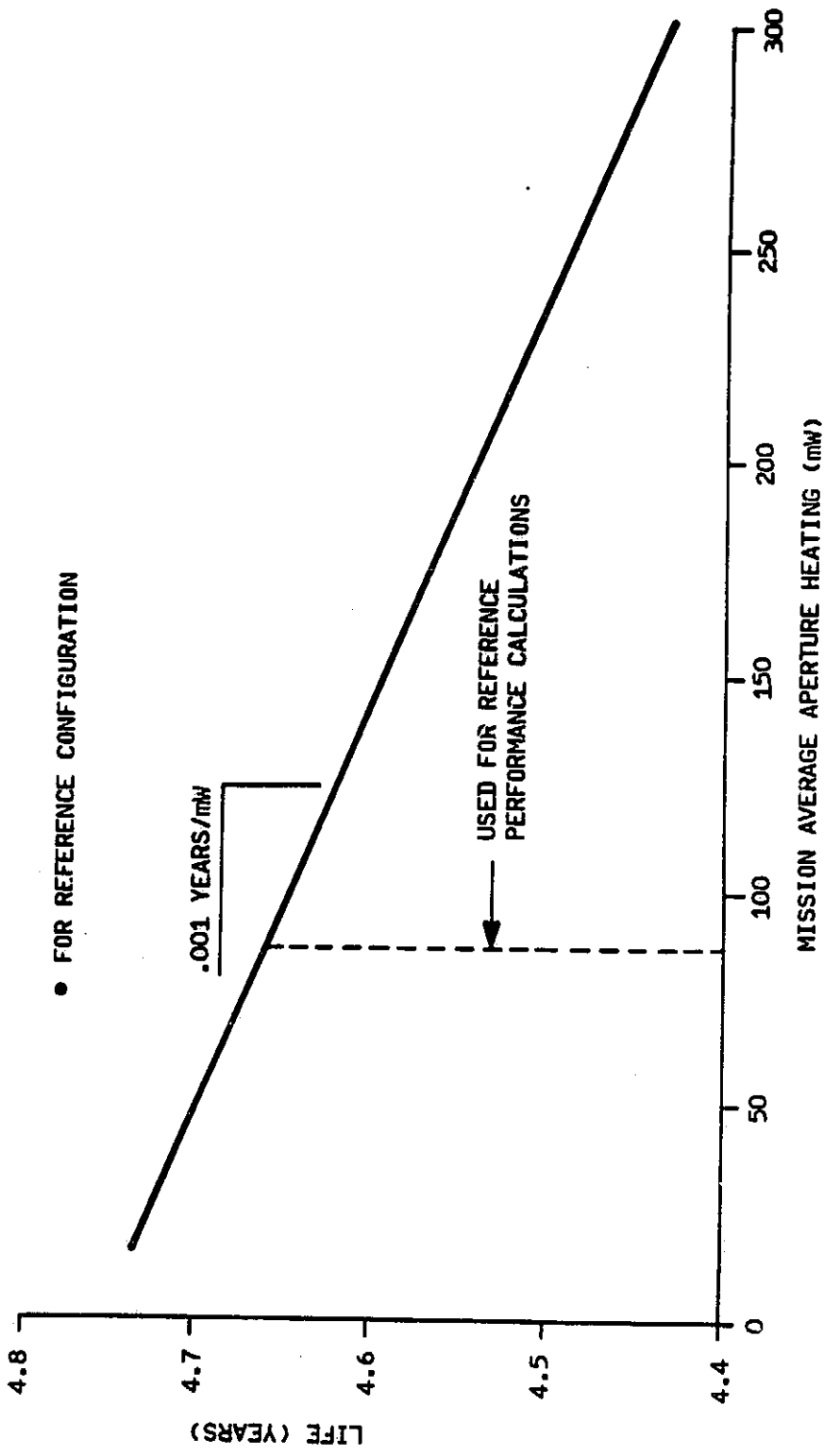

A/N 4742

EFFECT OF INSTRUMENT HEAT LOADS ON THE TOTAL MCT HEAT LOAD

A gaseous refrigeration system is by its very nature self-compensating. If we increase the heat load on the MCT, gaseous effluent flow is increased, the temperature of the vapor cooled shields decrease and therefore, the parasitic loads decrease. For the reference design this means that for every 1 mW added to the MCT, 0.55 mW are saved on parasitics for a net load of only 0.45 mW.

The curve shown illustrates this effect by varying the electrical dissipation at the cold instrument station. However, this data is applicable to other sources of MCT gains or losses.

EFFECT OF INSTRUMENT HEAT LOADS ON THE TOTAL MCT HEAT LOAD

- A GASEOUS REFRIGERATION SYSTEM IS SELF COMPENSATING
- AS HEAT IS ADDED TO MCT:
 - FLOW IS INCREASED SO PARASITIC HEAT LOAD TO MCT IS REDUCED
 - NET HEAT LOAD ON MCT IS ONLY 45% OF ORIGINAL ADDITION

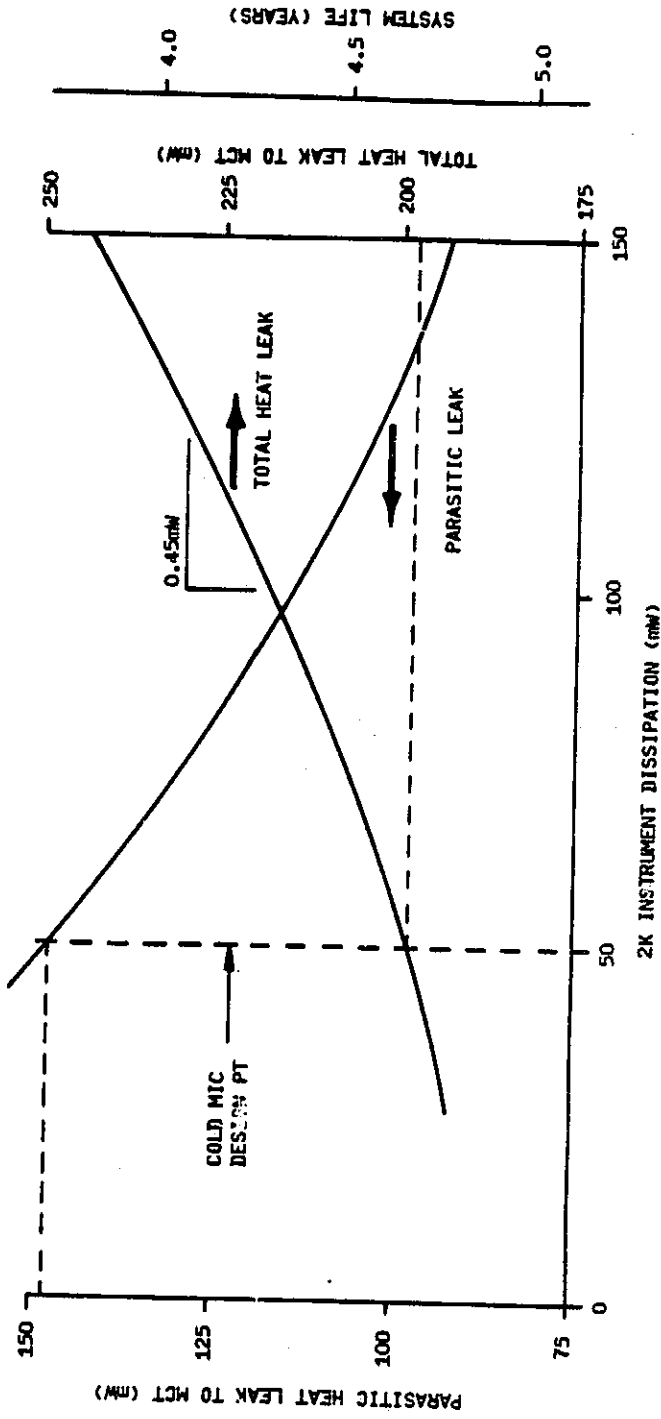

NOTE: SENSITIVITY ANALYSIS PERFORMED ON REFERENCE CONFIGURATION

A/N 4742

EFFECT OF OUTER SHELL TEMPERATURE ON LIFE

Mission life is greatly dependent on outer shell temperature with changes of 50°K worth 1.5 years. This sensitivity would be even worse except for the fact that only 55 percent of the MCT load is parasitic, the rest is a constant instrument load.

The 196°K baseline for the study is a reasonable outer shell temperature since IRAS was 196°K.

EFFECT OF OUTER SHELL TEMPERATURE ON LIFE

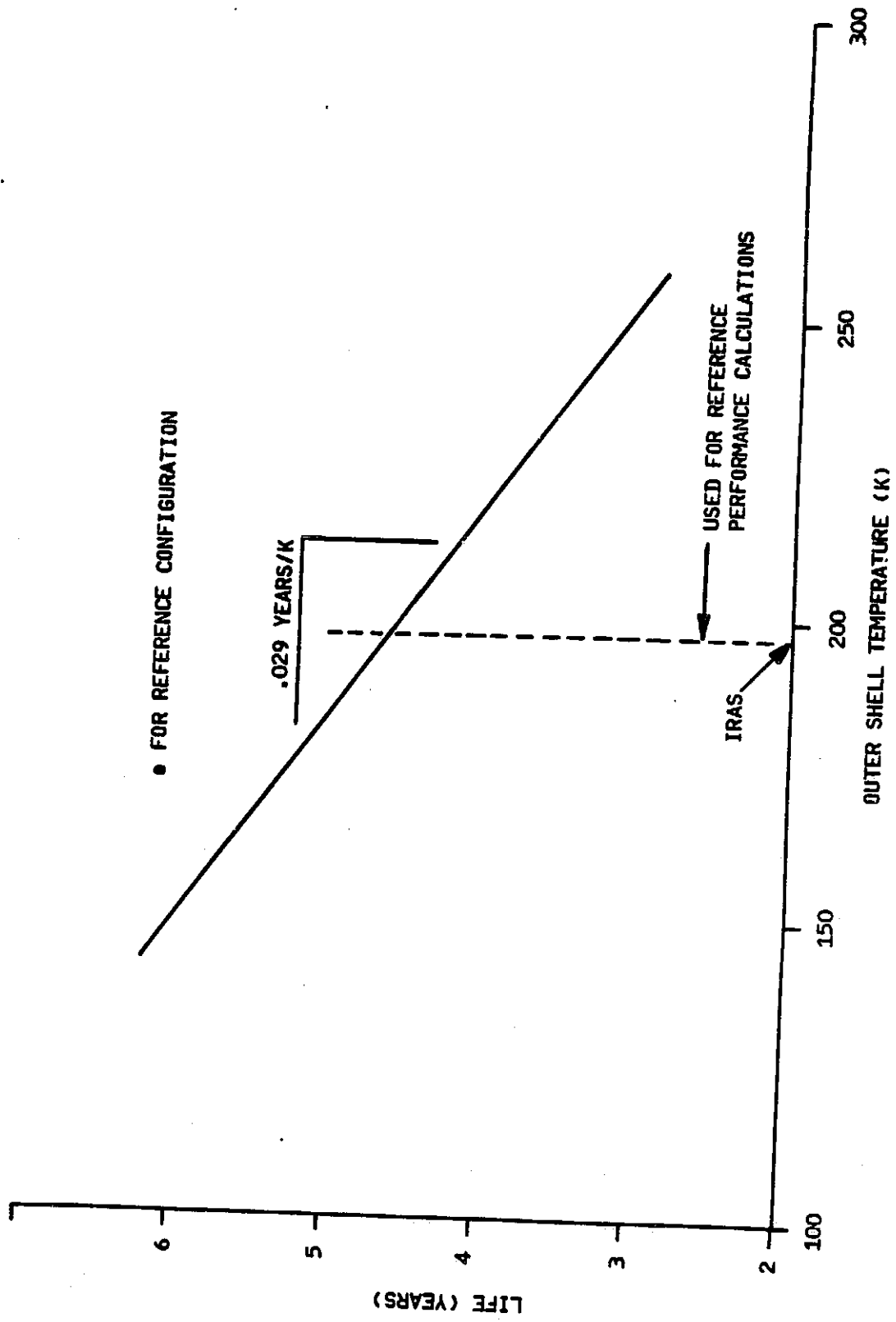

FOUR VAPOR COOLED SHIELDS OFFER SIGNIFICANT SYSTEM IMPROVEMENT

An examination of the reference configuration heat flow chart will show that MLI accounts for 77% of the heat loading on the OVCS. This is understandable in light of the dewar size, approximately 60 sq. meters.

A fourth vapor cooled shield decreases the heat load on the OVCS from 4.5 watts to 2.0 watts. The effect is that system life is increased to 5.8 years.

The addition of this fourth shield also reduced IVCS temperature from 28K to 19K which leads to less parasitic heat load in the forward baffle. The vapor cooling of the forward baffle is reduced due to the lower flow rate (7.1 mg/sec). The net effect is that the forward baffle remains at about the same temperature as the reference configuration.

FOUR VAPOR-COOLED SHIELDS OFFER SIGNIFICANT SYSTEM IMPROVEMENTS

- **LIFE INCREASE TO 5.8 YEARS**
- **FORWARD BAFFLE PEAK TEMPERATURE OF 14.2°K**
- **SMALL INCREASE IN WEIGHT \approx 100 Kg**

FOUR VAPOR COOLED SHIELD HEAT FLOWS

The following chart is a simplified heat flow summary of the configuration. The table at the bottom is the heat flows through each path in the thermal model. The path numbers referenced are those depicted in the "SIRTF THERMAL MODEL OVERVIEW" chart.

The vertical lines on the chart represent nodes. The horizontal lines represent the major heat flow paths. The double horizontal line represents the gaseous effluent flow. All units are (mW) unless otherwise noted.

Note that the disconnect reduced the heat load on the OVCS has been reduced from 4500 mW (reference configuration) to 2000 mW by the addition of the fourth VCS.

4 VAPOR COOLED SHIELDS, MISSION AVERAGE 83mW ON FORWARD BAFFLE

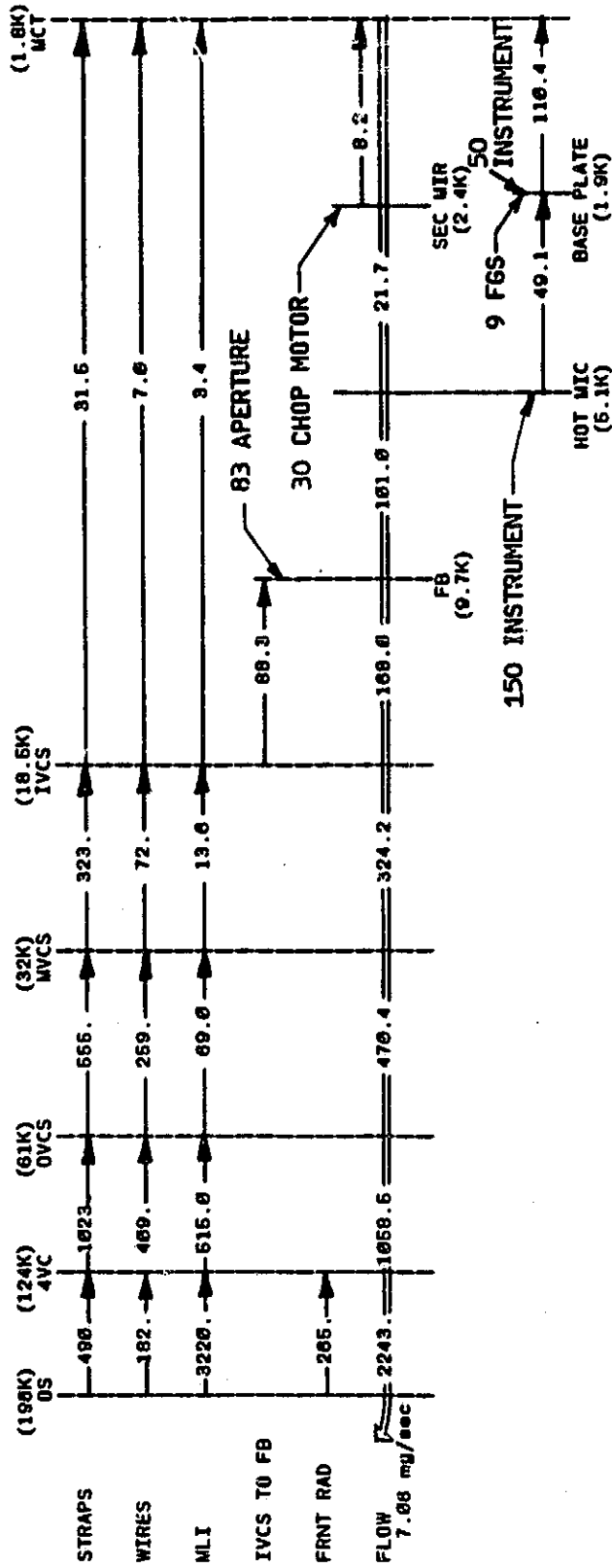

(DETAILED HEAT FLOWS THROUGH EACH CONDUCTOR)

101=2.17385E+01	QF	102=1.68885E+02	QF	103=1.68185E+02	QF	104=3.24197E+02	QF	105=4.70358E+02	QF	106=1.05854E+03
108=2.24338E+03	QF	219=2.43712E+02	QF	220=2.45973E+02	QF	221=6.08216E+02	QF	222=2.75880E+02	QF	223=1.06820E+02
224=1.67490E+01	QF	225=2.43708E+02	QF	226=5.15075E+02	QF	227=2.79330E+02	QF	228=1.02373E+02	QF	229=1.67850E+01
301=8.26231E+00	QF	302=1.16381E+02	QF	303=1.66893E+04	QF	304=7.15250E+05	QF	311=5.66804E+01	QF	312=3.67028E+04
313=3.57628E+04	QF	321=4.84476E+01	QF	322=6.68570E+01	QF	323=7.52018E+07	QF	331=8.28256E+00	QF	332=8.83898E+01
333=1.12613E+01	QF	334=3.82358E+01	QF	345=2.62272E+02	QF	346=2.32395E+02	QF	347=1.16122E+02	QF	348=1.44850E+02
349=2.35718E+02	QF	350=1.10942E+02	QF	351=1.48582E+02	QF	352=2.71405E+02	QF	363=4.10114E+01	QF	364=4.47291E+02
365=4.09880E+02	QF	366=2.58551E+02	QF	367=7.29189E+01	QF	368=4.99318E+00	QF	369=1.81043E+02	QF	374=1.65857E+02
506=1.37807E+02	QF	506=5.19880E+00	QF	507=9.32537E+02	QF	508=4.19389E+02	QF	509=4.78652E+01	QF	510=1.16580E+03
611=8.40505E+02	QF	612=3.17310E+02	QF	701=2.39749E+00	QF	702=2.42192E+00	QF	703=2.44071E+00	QF	704=8.47349E+01
711=1.62297E+00	QF	712=1.64686E+00	QF	713=1.66135E+00	QF	714=5.62957E+01	QF	721=9.26325E+01	QF	722=9.66280E+01
723=9.04710E+01	QF	724=3.21704E+01	QF	731=2.34699E+00	QF	732=2.30116E+00	QF	733=2.26798E+00	QF	734=7.92439E+01
801=1.46611E+02	QF	802=1.53672E+02	QF	803=1.59135E+02	QF	804=1.66183E+01	QF	811=1.96598E+01	QF	812=2.07712E+01
813=2.13013E+01	QF	814=7.22157E+00	QF	821=3.90780E+00	QF	822=4.13998E+00	QF	823=4.19995E+00	QF	824=1.40107E+00
831=1.75580E+01	QF	834=3.43543E+00	QF	841=9.68072E+02	QF	842=9.68865E+02	QF	843=9.54860E+02	QF	844=3.34958E+02
850=2.65574E+02	QF	1001=6.86995E+04	QF	1004=9.09869E+05	QF	1020=2.97334E+01	QF	1100=4.956097E-01	QF	

>>> FLOW RATE=0.7080E-02 gm/sec ESTIMATED LIFE= 5.767 years <<<

NOTE: ALL UNITS ARE (mW) UNLESS OTHERWISE NOTED

A/N 4742

THE EFFECT OF A SUPPORT DISCONNECT SYSTEM ON THE REFERENCE CONFIGURATION PERFORMANCE

The cryogen tank support straps provide 29% of the parasitic heat load on the MCT. By disconnecting these supports while on-orbit, either at the outer shell or MCT end of the supports, system life improvements should take place.

First, the disconnect located at the end of the supports near the outer shell offers little performance improvement. In the reference design the supports only contribute 11% of the heat loading on the OVCS. Therefore, there is little room for improvement.

Second, the disconnect located at the end of the supports near the MCT do offer 9% increase in life. In the reference design the straps account for 29% of MCT heat loading. When the disconnect is made 50 mW are saved on the support heat loads, but wires and MLI loads go up 30 mW.

**THE EFFECT OF A SUPPORT DISCONNECT SYSTEM
ON THE REFERENCE CONFIGURATION PERFORMANCE**

- **SUPPORT DISCONNECT "WEAK LINK" THERMAL CONDUCTANCE ASSUMED
TO BE 1/10 OF NORMAL CONDUCTANCE**
- **DISCONNECT ASSUMED AT HOT (OUTER SHELL) END OF SUPPORTS:
— LIFE INCREASED 5% (TO 4.86 YEARS)**
- **DISCONNECT ASSUMED AT COLD (MCT) END OF SUPPORTS:
— LIFE INCREASED 9% (TO 5.09 YEARS)**

***ASSUMED FORWARD BAFFLE ATTACHED TO IVCS**

DISCONNECT SYSTEM ON OUTER SHELL END OF TANK SUPPORT

The following chart is a simplified heat flow summary of the configuration. The table at the bottom is the heat flows through each path in the thermal model. The path numbers referenced are those depicted in the "SIRTF THERMAL MODEL OVERVIEW" chart.

The vertical lines on the chart represent nodes. The horizontal lines represent the major heat flow paths. The double horizontal line represents the gaseous effluent flow. All units are (mW) unless otherwise noted.

Note that the disconnect reduced the heat load on the IVCS (contributed by the straps) from 510 mW (reference configuration) to 70 mW. However, the 3500 mW load on the OVCS by way of the MLI dominates.

DISCONNECT ON HOT SIDE, 83mW MISSION AVERAGE ON FORWARD BAFFLE

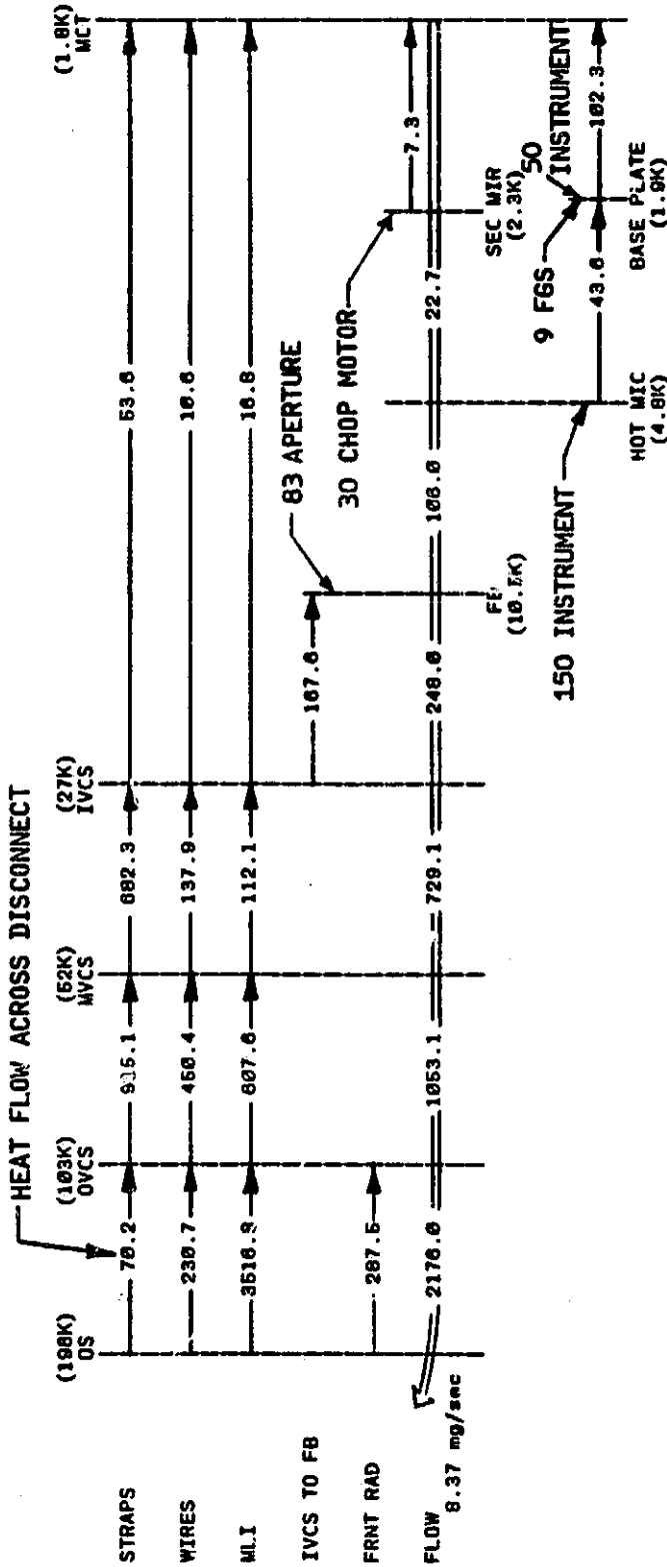

(DETAILED HEAT FLOWS THROUGH EACH CONDUCTOR)

101=2.27169E+01	QF	102=1.00420E+02	QF	103=2.40030E+02	QF	104=7.29094E+02	QF	105=7.29094E+02	QF	106=1.06309E+03	QF	107=2.17598E+03
218=3.49771E+01	QF	221=3.51790E+01	QF	222=4.53022E+02	QF	223=3.88731E+02	QF	224=2.07519E+01	QF	225=3.49776E+01	QF	226=3.49776E+01
226=4.61289E+04	QF	227=3.43630E+02	QF	228=2.68575E+01	QF	301=7.29478E+00	QF	302=1.02323E+02	QF	303=0.00000E+00	QF	304=1.19209E-04
304=1.19209E-04	QF	311=4.99894E+01	QF	312=6.96040E-04	QF	313=6.96040E-04	QF	321=4.29852E+01	QF	322=6.93195E-01	QF	323=6.93195E-01
330=2.11009E-06	QF	331=7.28498E+00	QF	332=1.67573E+02	QF	333=0.74708E+00	QF	334=4.10008E+01	QF	340=4.18618E+02	QF	341=4.18618E+02
347=1.15153E+02	QF	348=3.11984E+02	QF	349=4.26265E+02	QF	350=1.77810E+02	QF	351=3.10099E+02	QF	352=3.85775E+01	QF	353=3.85775E+01
364=6.78875E-02	QF	365=2.30879E+02	QF	366=4.56379E+02	QF	367=1.37802E+02	QF	368=1.00230E+01	QF	369=9.10809E+02	QF	370=9.10809E+02
505=3.31424E+02	QF	506=5.60667E+01	QF	507=1.29243E+03	QF	508=7.74543E+02	QF	509=3.42040E+02	QF	510=2.97085E+00	QF	511=2.97085E+00
702=2.92239E+00	QF	703=2.89328E+00	QF	704=1.01232E+00	QF	711=3.68800E+00	QF	712=3.05834E+00	QF	713=3.05834E+00	QF	714=1.08180E+00
714=1.08180E+00	QF	721=1.87811E+00	QF	722=1.95815E+00	QF	723=1.95815E+00	QF	724=0.71457E-01	QF	701=2.97085E+00	QF	702=2.97085E+00
-802=1.04916E+03	QF	-803=1.04600E+03	QF	-804=3.07430E+02	QF	-811=1.70937E+02	QF	-812=1.81699E+02	QF	-813=1.80423E+02	QF	-814=1.80423E+02
-814=1.80423E+02	QF	-821=3.17673E+01	QF	-822=3.38308E+01	QF	-823=3.46174E+01	QF	-824=1.19093E+01	QF	-831=8.61490E-01	QF	-832=8.61490E-01
-834=1.68180E+01	QF	-850=2.87522E+02	QF	-1001=9.25013E-04	QF	-1004=1.22380E-04	QF	-1004=1.22380E-04	QF	-1020=3.98850E-01	QF	-1100=2.56174E-01

>>> FLOW RATE=0.0367E-02 gm/sec ESTIMATED LIFE= 4.680 years <<<

NOTE: ALL UNITS ARE (mW) UNLESS OTHERWISE NOTED.

DISCONNECT SYSTEM ON MCT END OF TANK SUPPORT

The following chart is a simplified heat flow summary of the configuration. The table at the bottom is the heat flows through each path in the thermal model. The path numbers referenced are those depicted in the "SIRTF THERMAL MODEL OVERVIEW" chart.

The vertical lines on the chart represent modes. The horizontal lines represent the major heat flow paths. The double horizontal line represents the gaseous effluent flow. All units are (mW) unless otherwise noted.

Note that the disconnect reduces the heat load on the MCT from 58 mW (reference configuration) to 7.7 mW. However, the other parasitics rose from 39.4 mW (reference configuration) to 69.4. This offsets much of the gain accrued by using the disconnect system.

DISCONNECT ON COLD SIDE, 83mW MISSION AVERAGE ON FORWARD BAFFLE

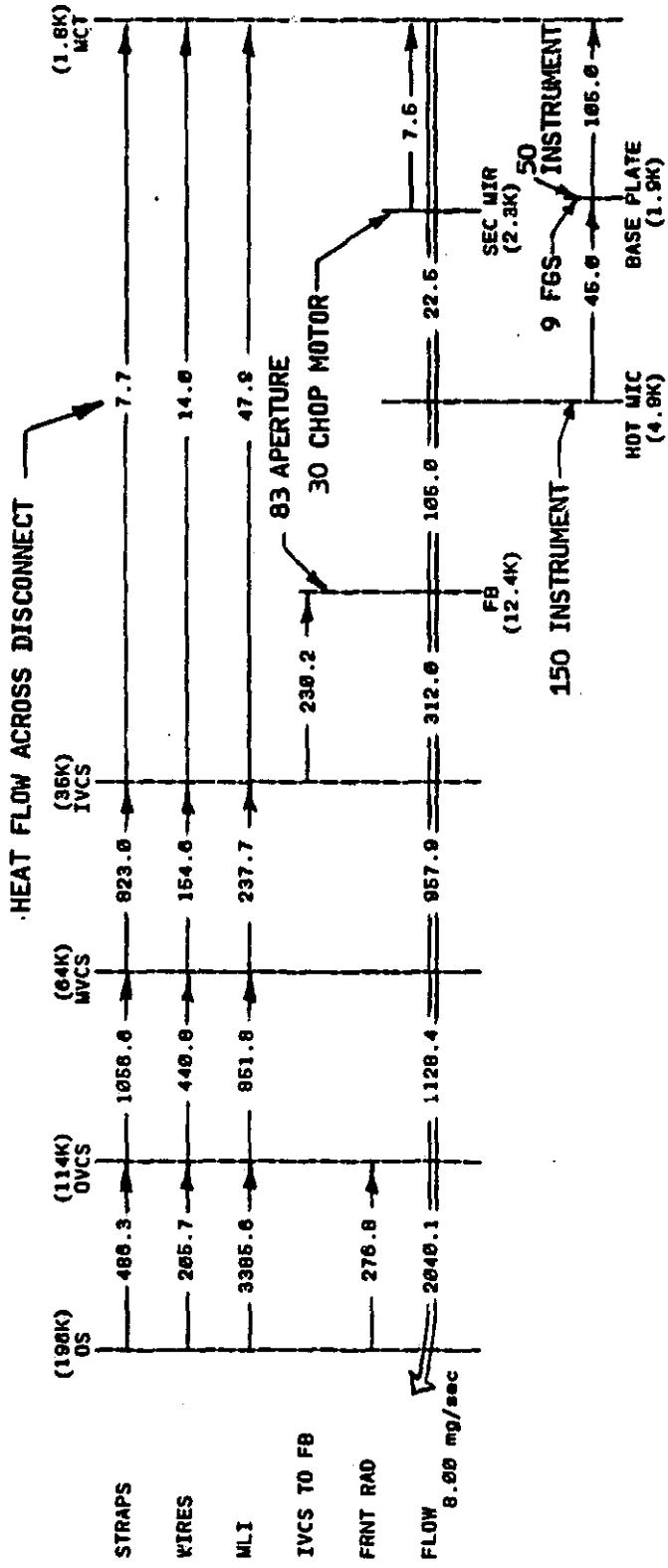

(DETAILED HEAT FLOWS THROUGH EACH CONDUCTOR)

101=2.24092E+01	QF	102=1.05012E+02	QF	103=3.11084E+02	QF	105=9.57092E+02	QF	106=1.12042E+03	QF	107=2.04014E+03	QF
219=2.42336E+02	QF	221=2.43968E+02	QF	222=5.24736E+02	QF	223=4.08030E+02	QF	224=3.95205E+00	QF	225=2.42334E+02	QF
226=5.31875E+02	QF	227=4.14329E+02	QF	228=3.07895E+00	QF	301=7.53487E+00	QF	302=1.05509E+02	QF	303=4.52995E+04	QF
304=2.14577E-04	QF	311=5.90009E+01	QF	312=9.63874E-04	QF	313=9.53874E-04	QF	321=4.43766E+01	QF	322=6.12398E-01	QF
330=2.00272E-06	QF	331=7.53383E+00	QF	332=2.30188E+02	QF	333=1.00139E+01	QF	334=3.96170E+01	QF	340=2.00788E+02	QF
347=1.16093E+02	QF	348=4.04729E+02	QF	349=2.89584E+02	QF	350=1.17489E+02	QF	351=4.10447E+02	QF	363=3.78661E+01	QF
364=8.96507E-02	QF	365=2.56873E+02	QF	366=4.40772E+02	QF	367=1.54586E+02	QF	368=1.40286E+01	QF	504=9.55688E+02	QF
505=3.72791E+02	QF	508=6.70709E+01	QF	507=1.26537E+03	QF	509=7.50786E+02	QF	509=2.99448E+02	QF	701=2.06422E+00	QF
702=2.60559E+00	QF	703=2.57664E+00	QF	704=9.01498E-01	QF	711=2.94989E+00	QF	712=2.99114E+00	QF	713=3.02830E+00	QF
714=1.05834E+00	QF	721=2.10412E+00	QF	722=2.17077E+00	QF	723=2.19891E+00	QF	724=7.53009E+02	QF	-801=1.01609E+03	QF
-802=1.00994E+03	QF	-803=1.60580E+03	QF	-804=3.53106E+02	QF	-811=2.46978E+02	QF	-812=2.54860E+02	QF	-813=2.03372E+02	QF
-814=9.28449E+01	QF	-821=6.74407E+01	QF	-822=7.18585E+01	QF	-823=7.33609E+01	QF	-824=2.52307E+01	QF	-631=2.47332E+00	QF
-834=4.79391E+01	QF	-850=2.78775E+02	QF	-1001=1.79839E-03	QF	-1004=2.37783E-04	QF	-1020=7.78495E-01	QF	-1100=3.58763E-01	QF

>>> FLOW RATE=0.0003E-02 gm/sec ESTIMATED LIFE= 5.087 years <<<

NOTE: ALL UNITS ARE (mW) UNLESS OTHERWISE NOTED.

SECONDARY MIRROR ASSEMBLY MOUNTING TRADEOFFS

Two different methods of thermally controlling the secondary mirror were examined.

The first was the reference configuration, where the assembly is mounted to but thermally isolated from the aft baffle and is vapor cooled.

Alternate I was with the assembly thermally mounted to the aft baffle. There is no need to vapor cool it with this concept. However, the entire chopper motor dissipation is absorbed by the MCT.

Alternate II was the mirror assembly and the forward baffle mounted to the aft baffle. In the 28.5° orbit temperature fluctuations in the forward baffle would be transmitted to the aft baffle, and the mirror assembly.

At 3K and 200 μ m mirror stability requirement is $\Delta T < 0.96K$. Using mirror stability as a selection criteria, the reference or Alternate I is best. However, all are acceptable since the mirror temperature in all cases is less than 2.5K.

Using system life as a selection criterion the reference configuration is the best. The reference configuration is the most decoupled from life due to the vapor cooling. This criterion is important for high chopper motor dissipations. It may become unimportant if chopper motor power is only 5mW.

SECONDARY MIRROR ASSEMBLY MOUNTING TRADEOFFS

- REFERENCE CONFIGURATION:
 - MIRROR ASSEMBLY MOUNTED WITH ISOLATORS TO AFT BAFFLE
 - MIRROR ASSEMBLY VAPOR COOLED
 - FORWARD BAFFLE MOUNTED TO IVCS
 - MIRROR ΔT IS $\sim 0.01^{\circ}\text{K}$
 - LIFE SENSITIVITY IS NEGLIGIBLE (0.0045 YEAR/mW)

- ALTERNATE I:
 - MIRROR ASSEMBLY HARD (THERMALLY) MOUNTED TO AFT BAFFLE
 - MIRROR ASSEMBLY NOT VAPOR COOLED
 - FORWARD BAFFLE MOUNTED TO IVCS
 - MIRROR ΔT IS $< 0.01^{\circ}\text{K}$
 - LIFE SENSITIVITY TO CHOPPER MOTOR POWER IS 0.0087 YEARS/mW

- ALTERNATE II:
 - MIRROR ASSEMBLY AND FORWARD BAFFLE MOUNTED TO AFT BAFFLE
 - MIRROR ASSEMBLY NOT VAPOR COOLED
 - MIRROR ΔT IS $\sim 0.13^{\circ}\text{K}$ (DURING SOLAR AVOIDANCE MANEUVER)
 - LIFE SENSITIVITY TO CHOPPER MOTOR POWER IS 0.0087 YEARS/mW

EFFECT OF CHOPPER MOTOR DISSIPATION ON MIRROR TEMPERATURE

Chopper motor dissipation of 5 mW may be possible. However, 30 mW was used in the reference so as to include design margin.

As was stated earlier, secondary mirror stability is not a problem at 200 μ m, as long as the mirror is less than 3 $^{\circ}$ K. The secondary mirror is at 2.3 $^{\circ}$ K for the reference configuration and would not reach 3 $^{\circ}$ K unless the chopper motor dissipation went up to 72 mW (unlikely).

EFFECT OF CHOPPER MOTOR DISSIPATION ON SECONDARY MIRROR TEMPERATURE

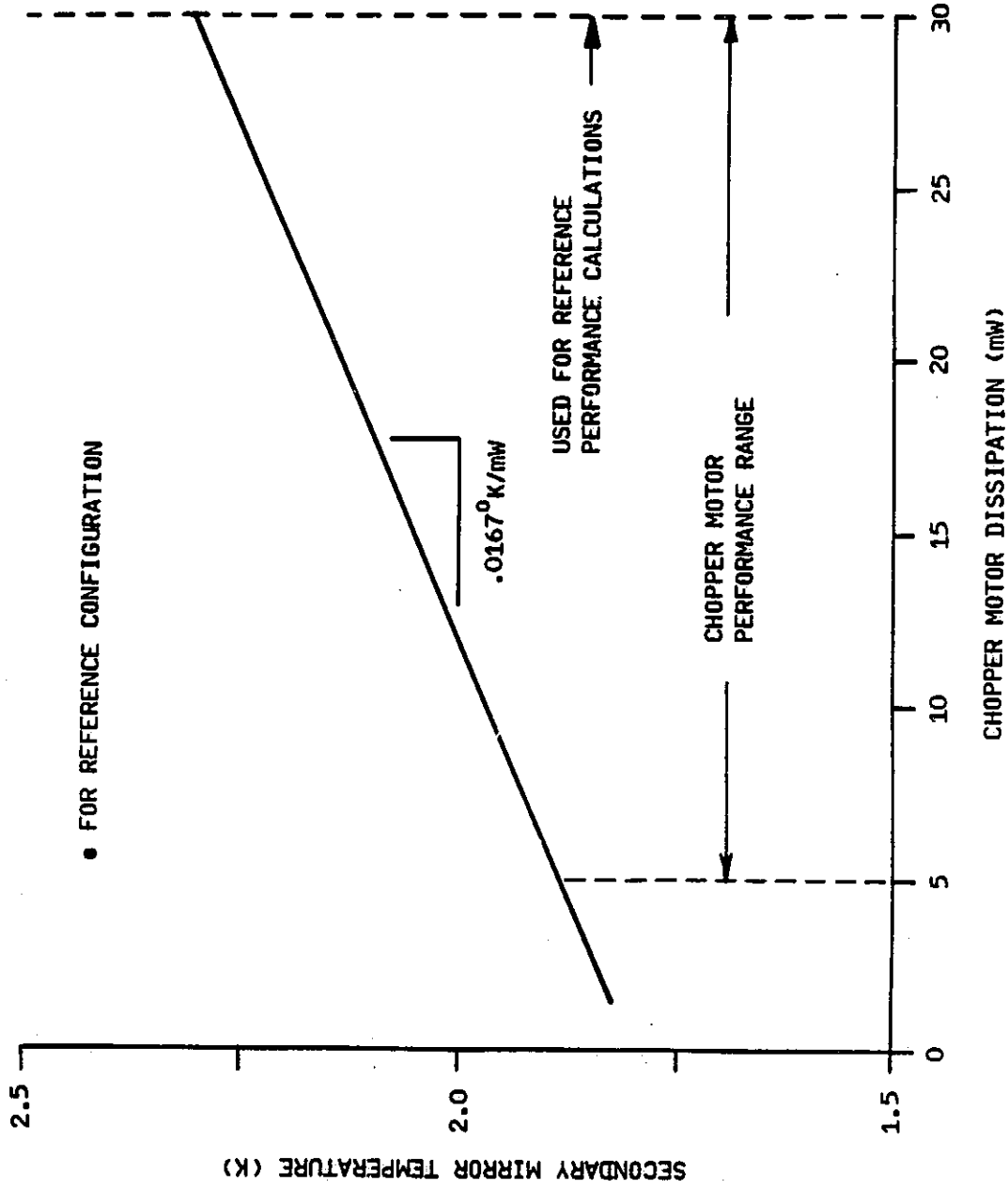

EFFECT OF CHOPPER MOTOR DISSIPATION ON SYSTEM LIFE

For the reference configuration the effect of chopper motor dissipation on mission life is negligible at .0045 years/mW. This is due to vapor cooling which carries 75 percent away from the MCT. For Alternate I or II the life sensitivity is almost double the reference configuration. However, for the low power dissipation expected this is probably not a problem.

EFFECT OF CHOPPER MOTOR DISSIPATION ON LIFE FOR DIFFERENT MOUNTING SCHEMES

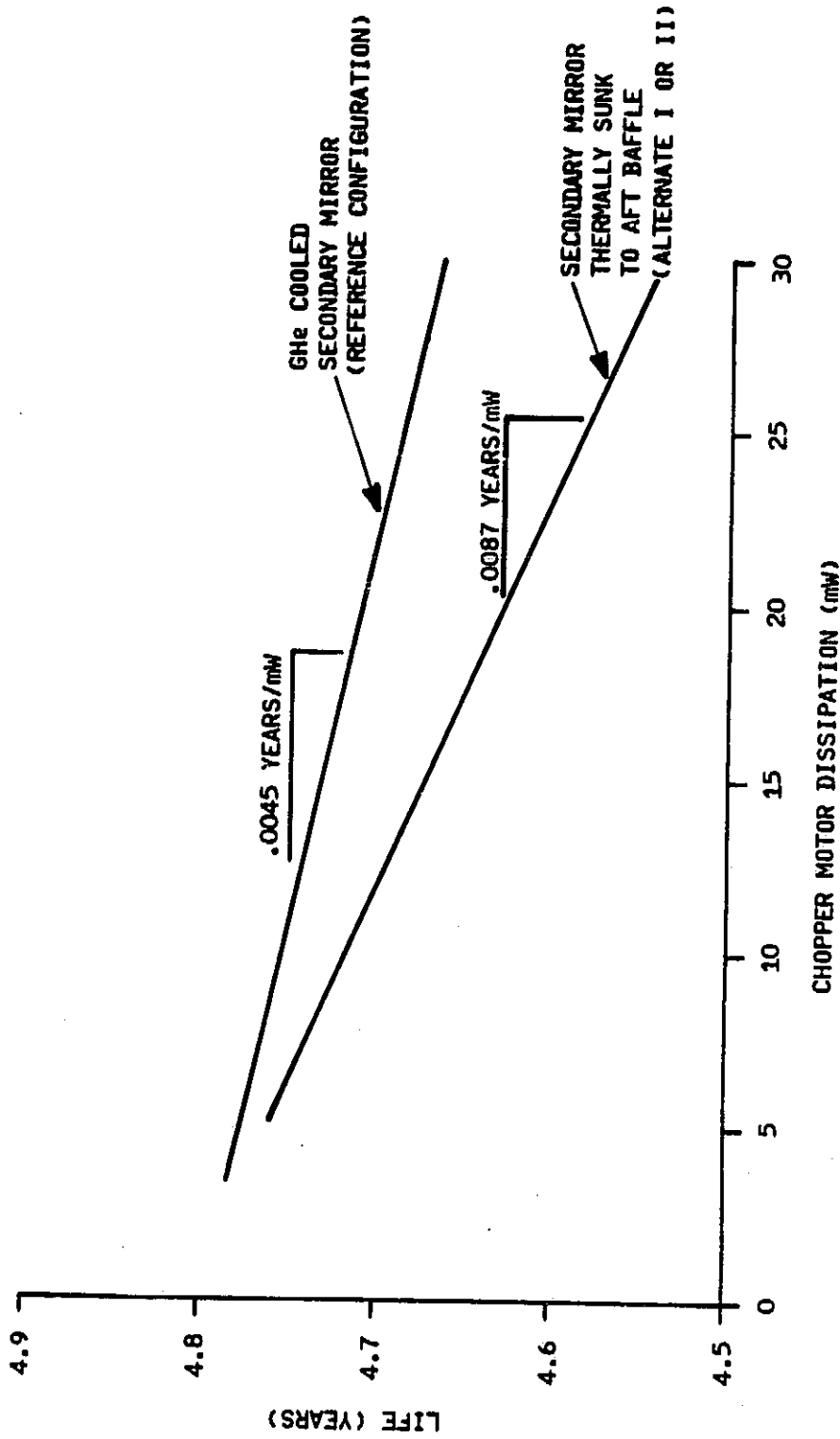

EFFECT OF FORWARD BAFFLE MOUNTING ON SECONDARY MIRROR TEMPERATURE

As was stated earlier, if the mirror assembly and the forward baffle are both attached to the aft baffle there is the possibility of temperature interaction between the two during the solar avoidance maneuver. Since the forward baffle is mounted with isolators to the aft baffle, while the mirror assembly is hard mounted, temperature excursion is not excessive. It is 0.13K while the mirror is always below 2.6K.

EFFECT OF FOREBAFFLE MOUNTING ON SECONDARY MIRROR TEMPERATURE

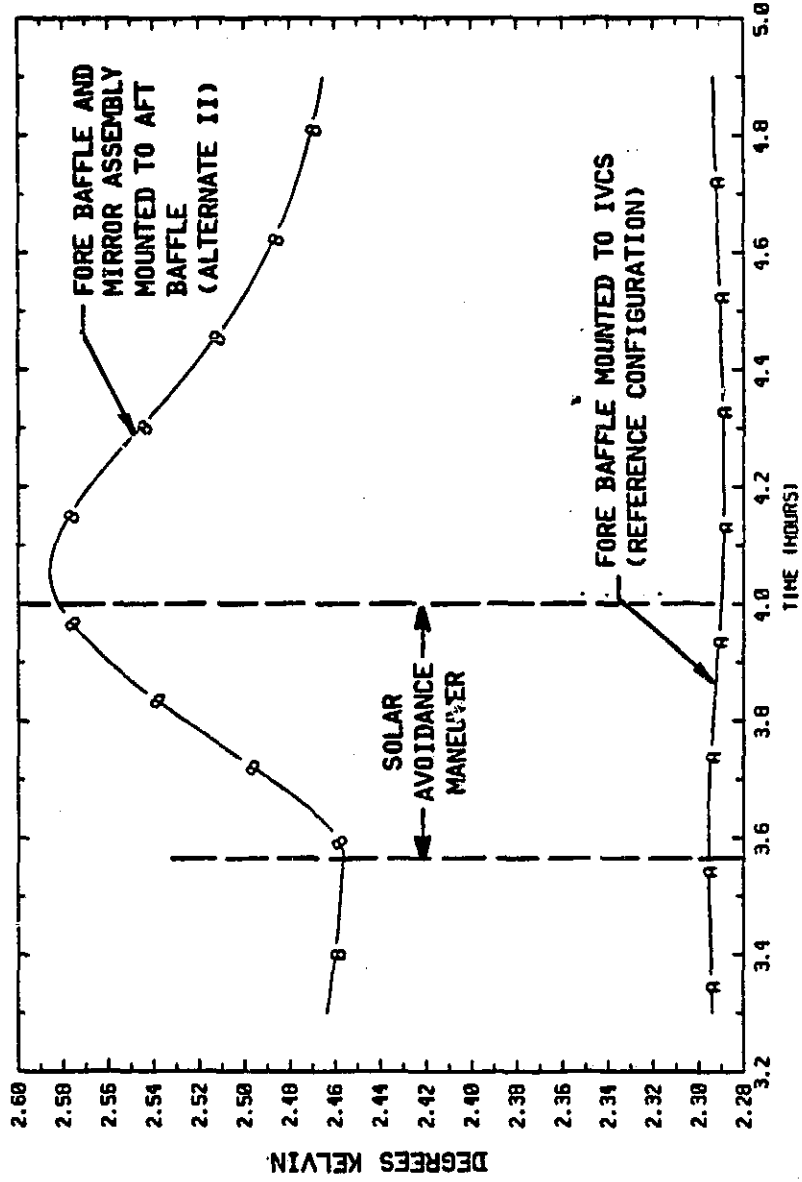

EFFECTS OF COLDER FOREBAFFLE CONFIGURATION

Altering the reference configuration by attaching the forebaffle to the aft baffle instead of the inner vapor-cooled shield affects the forebaffle temperature as shown here. The temperature swings are largest in the 28.5° orbit because of the varying amount of scattered radiation from the earth received as the telescope tips toward and away from the earth during the sun-avoidance maneuver.

The best situation from a thermal standpoint is when the telescope is viewing near zenith or tipped away from the earth so that earth shine and albedo never enter the mouth of the shade. This will be possible most of the time when $\beta = 51^\circ$. The colder configuration then reduces the forebaffle temperature from 9.8K to 4.9K.

The worst situation from the thermal standpoint is when $\beta = 0$, and the satellite passes directly over the sub-solar point. Realistic operating scenarios will probably combine astronomical observations over part of the orbit with the sun-avoidance maneuver during the rest. To get a worst-case bound on the behavior of the cryogenic system, we have assumed that the telescope is pointed within 57.9° of the earth (the design limit of the shade) continuously during the orbit. A less stringent case assumes that the telescope is pointed at the earth limit during the sun avoidance maneuver, and then near zenith for the balance of the orbit. Transient thermal analysis assuming these orbits repeat over and over then predicts the thermal excursions shown.

The temperature of the forebaffle is more stable in the 98° orbit because there are no sun-avoidance maneuvers required, and slightly lower because the viewfactor from the shade to the forebaffle is smaller.

EFFECTS OF COLDER FOREBAFFLE CONFIGURATION

	FOREBAFFLE TEMPERATURE (K)		
	REFERENCE CONFIGURATION ¹	COLDER CONFIGURATION ²	DUAL-CRYOGEN ³
28.5° ORBIT:			
• BEST CASE LIMIT ($\beta = 51^\circ$)	9.8	4.9	10.4
• INTERMEDIATE CASE ($\beta = 0^\circ$, LOOKING NEAR ZENITH EXCEPT DURING SOLAR AVOIDANCE MANEUVER)	12.3 - 14.3	6.6 - 10.3	10.4
• WORST CASE LIMIT ($\beta = 0^\circ$, TIPPED TOWARD EARTH LIMB 100% OF TIME)	15.8 - 16.8	9.6 - 11.8	10.4
98° ORBIT:			
• BEST CASE LIMIT (LOOKING NEAR ZENITH)	9.3	4.5	≈10.0
• WORST CASE LIMIT (TIPPED TOWARD EARTH LIMB 100% OF TIME)	10.0	6.1	≈10.0

1. FOREBAFFLE ATTACHED TO INNER VAPOR-COOLED SHIELD
2. FOREBAFFLE ATTACHED TO AFT BAFFLE
3. FOREBAFFLE ATTACHED TO SOLID HYDROGEN TANK

FOREBAFFLE TEMPERATURE FOR TWO CONFIGURATIONS - BEST THERMAL SCENARIO AT SOLAR AVOIDANCE

The effect of two different cryogenic configurations on the temperature stability of the forebaffle during the sun-avoidance maneuver is explored here for the best possible thermal scenario when the orbit includes the solar-avoidance maneuver at $\beta = 0$.

The best-case limit on the viewing scenario from a thermal point of view consists of viewing near zenith so that no earth shine or albedo enters the mouth of the sunshade. This is impossible to do continuously in the 28.5° orbit because sun-avoidance maneuvers are required. The worst orbits are those for which the sun lies in the plane of the orbit, i.e., when $\beta = 0$.

For these orbits, the best possible thermal scenario would involve slewing the telescope instantaneously to zenith after the completion of the avoidance maneuver, and keeping it there until the avoidance maneuver on the next orbit. This produces the scattered radiation heat load on the forebaffle given by the dashed curve. An additional 145 mW of thermal radiation from the sunshade is also included in the calculation, but not shown here.

The reference configuration has the forebaffle cooled by the effluent helium gas in a heat exchanger, and mechanically mounted to the inner vapor-cooled shield (IVCS). The thermal isolator connecting the baffle to the IVCS is assumed to have a conductance of 10 mW/K, a value that is consistent with preliminary structural analysis of the mounting. This configuration experiences a temperature excursion between 12.3K and 14.3K during this orbit.

An alternate configuration has the forebaffle cooled by a gas heat exchanger as before, but mounted to the aft baffle instead of the IVCS. The thermal conductance of the mounting structure is again taken to be 10 mW/K. This configuration eliminates the heat leaking from the IVCS to the forebaffle, thereby, reducing its temperature. The temperature excursion during this orbit then becomes 6.6K to 10.3K.

**FOREBAFFLE TEMPERATURE FOR TWO CONFIGURATIONS--
BEST THERMAL SCENARIO AT SOLAR AVOIDANCE
(SOLAR AVOIDANCE MANEUVER ($\beta = 0$) FOLLOWED BY
ZENITH VIEWING, 28.5° ORBIT)**

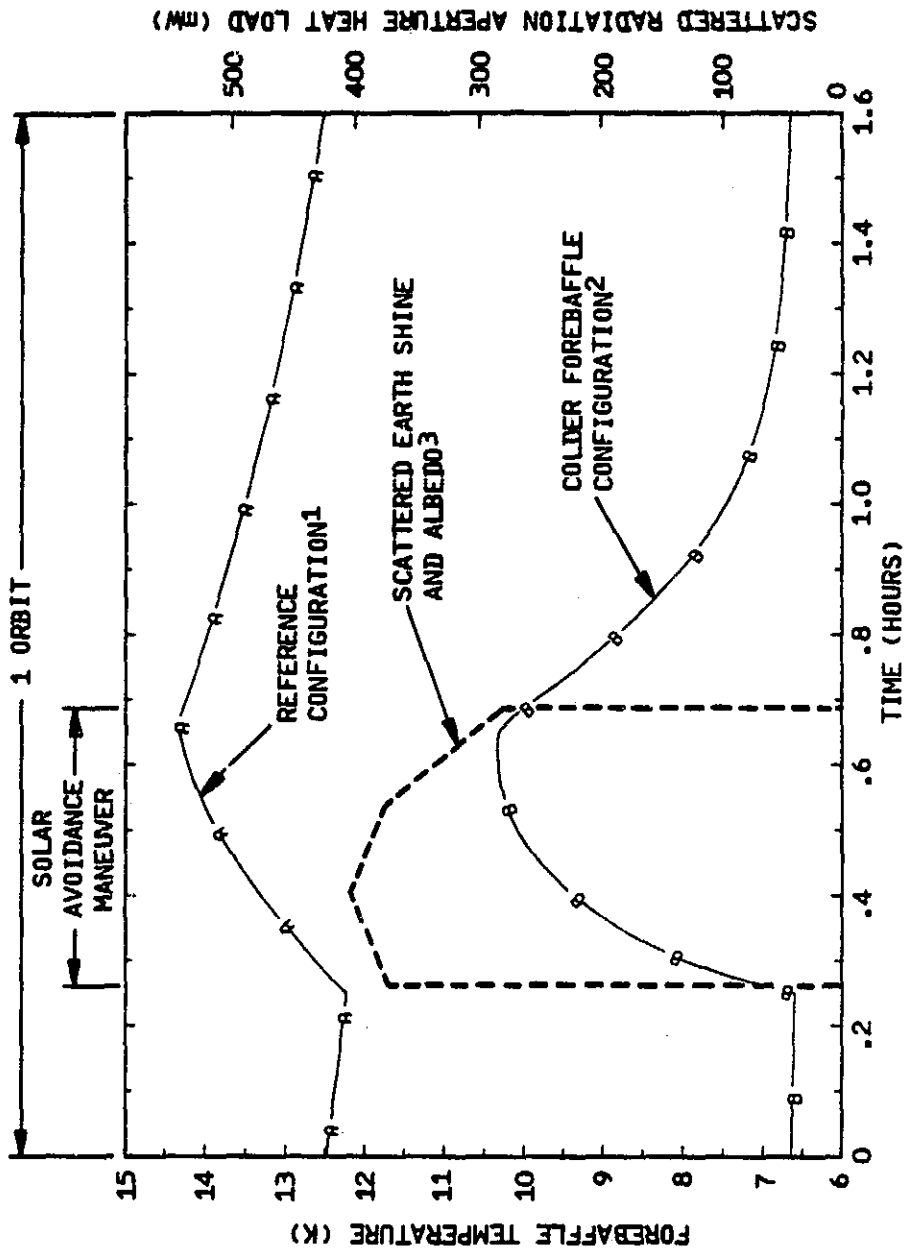

NOTES:

1. FOREBAFFLE ATTACHED TO INNER VAPOR-COOLED SHIELD THROUGH 10 mm/K THERMAL ISOLATOR
2. FOREBAFFLE ATTACHED TO AFT BAFFLE THROUGH SAME THERMAL ISOLATOR
3. CONSTANT 145 mW THERMAL RADIATION FROM SUNSHADE NOT SHOWN

FOREBAFFLE TEMPERATURE FOR TWO CONFIGURATIONS - WORST POSSIBLE THERMAL SCENARIO

The effect of two different cryogenic configurations on the temperature stability of the forebaffle during the sun-avoidance maneuver is explored here for the worst possible thermal scenario.

The worst-case limit on the viewing scenario from a thermal point of view is defined by tipping the telescope within 58.9° of the earth limb (the design limit of the sunshade) and keeping it there. This produces a scattered radiation heat load on the forebaffle given by the dashed curve. The broad peak is due to the reflected sunlight (albedo) on the day side of the earth, and the plateau is due to the infrared earthshine which is essentially constant. An additional 177 mW of thermal radiation from the sunshade is also included in the calculation, but not shown here.

The reference configuration has the forebaffle cooled by the effluent helium gas in a heat exchanger, and mechanically mounted to the inner vapor-cooled shield (IVCS). The thermal isolator connecting the baffle to the IVCS is assumed to have a conductance of 10 mW/K , a value that is consistent with preliminary structural analysis of the mounting. This configuration experiences a temperature excursion between 15.8K and 16.8K during this orbit.

An alternate configuration has the forebaffle cooled by a gas heat exchanger as before, but mounted to the aft baffle instead of the IVCS. The thermal conductance of the mounting structure is again taken to be 10 mW/K . This configuration eliminates the heat leaking from the IVCS to the forebaffle, thereby reducing its temperature. The temperature excursion during this worst-case orbit then becomes 9.6K to 11.8K .

**FOREBAFFLE TEMPERATURE FOR TWO CONFIGURATIONS -
 WORST POSSIBLE THERMAL SCENARIO (TIPPED TOWARD
 EARTH LIMB CONTINUOUSLY AT $\beta = 0, 28.5^\circ$ ORBIT)**

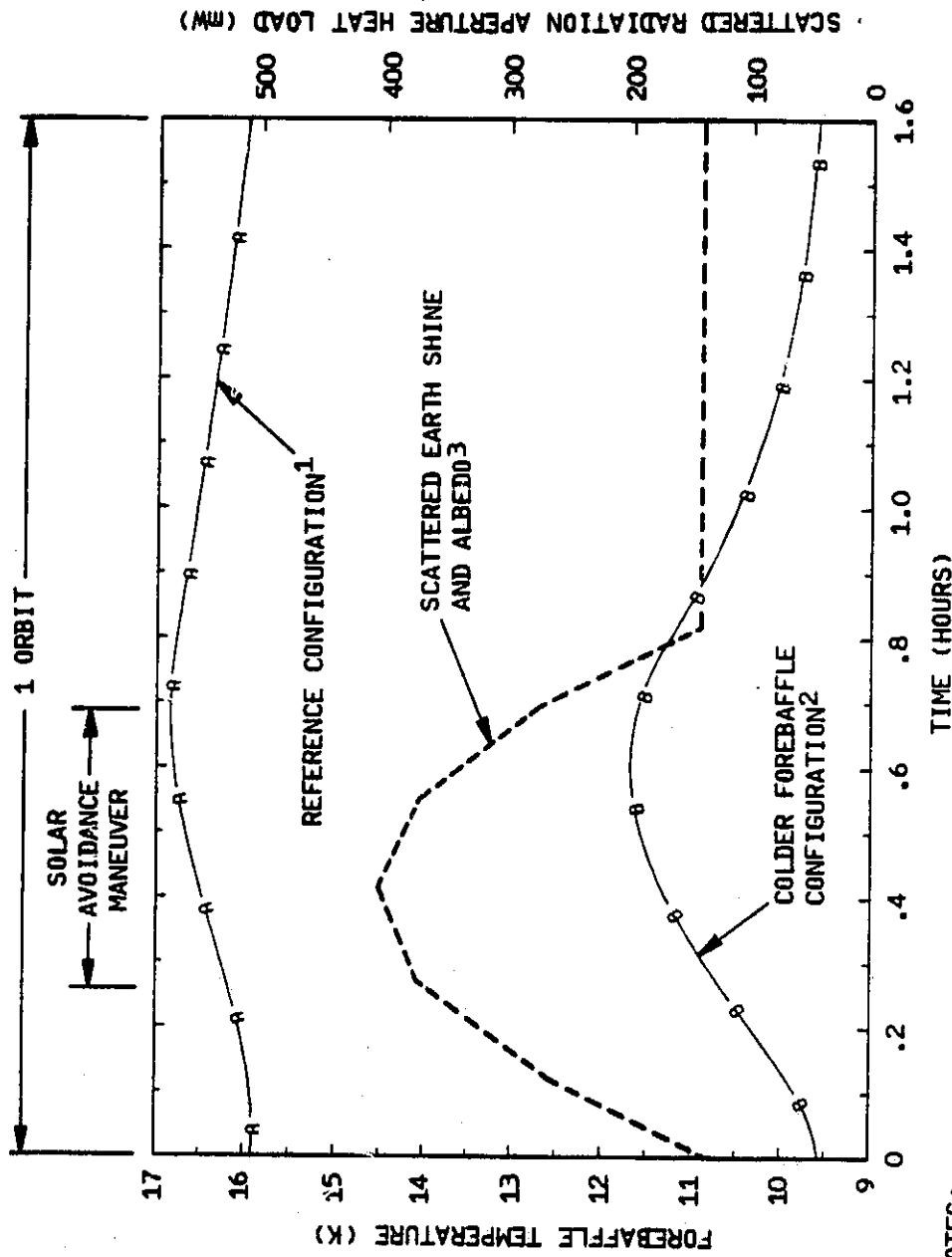

NOTES:

1. FOREBAFFLE ATTACHED TO INNER VAPOR-COOLED SHIELD THROUGH 10 mW/K THERMAL ISOLATOR
2. FOREBAFFLE ATTACHED TO AFT BAFFLE THROUGH SAME THERMAL ISOLATOR
3. CONSTANT 177 mW THERMAL RADIATION FROM SUNSHADE NOT SHOWN

FORWARD BAFFLE TEMPERATURE SENSITIVITY TO MOUNTING THERMAL ISOLATION

An examination of the reference configuration heat balance chart will show that heat path from the IVCS to the forward baffle is a driver to forward baffle temperature since IVCS always is warmer than the forward baffle. A calculated value for this path is 5 mW/K while our reference configuration uses 10 mW/K.

The "colder forebaffle configuration" has the forward baffle mounted to the aft baffle with a thermal isolator of 10 mW/K. Since the aft baffle is always colder than the forward baffle, increases in the value of this thermal path will only drive forward baffle temperature down.

FORWARD BAFFLE PEAK TEMPERATURE SENSITIVITY TO MOUNTING THERMAL ISOLATION

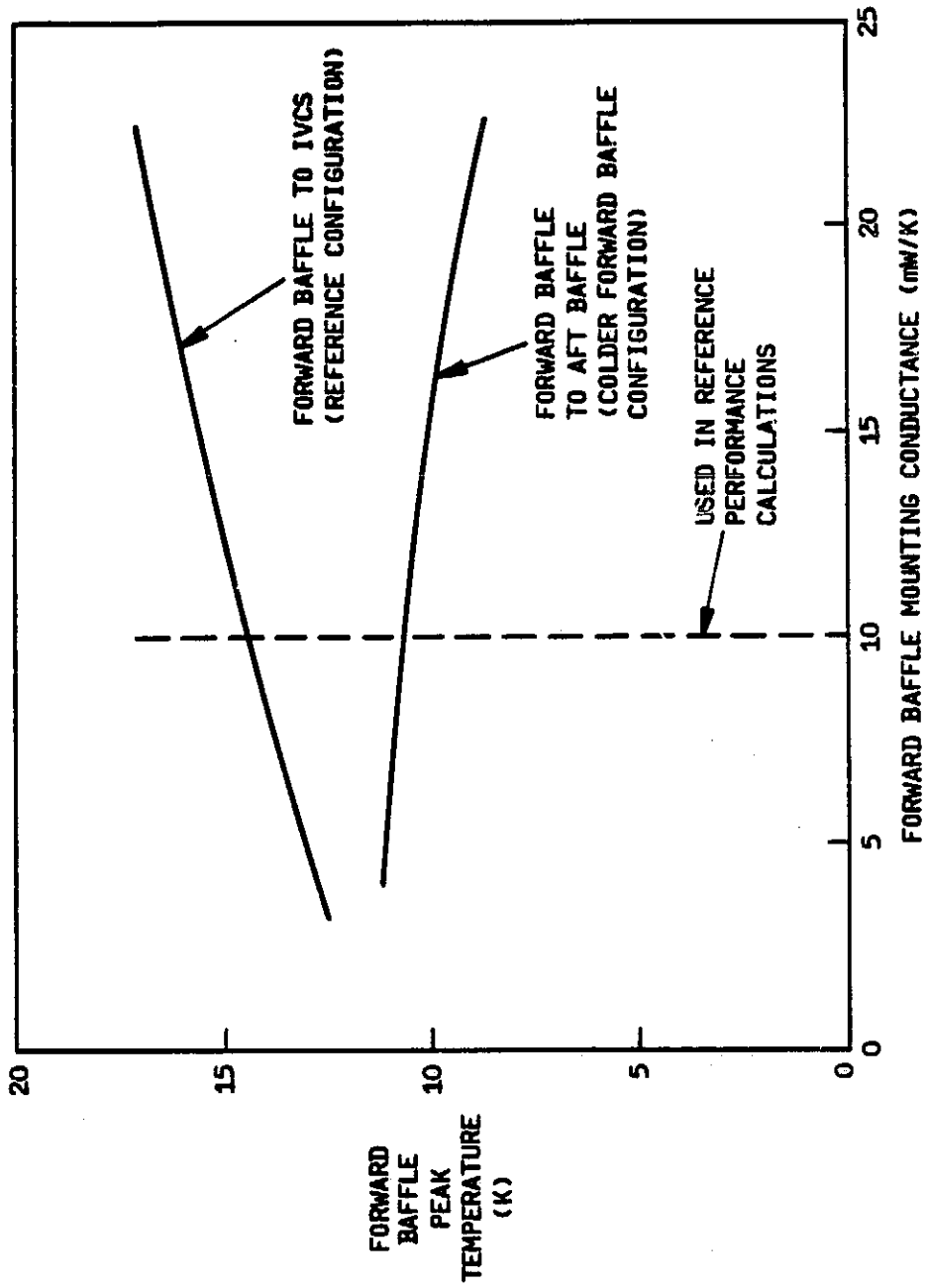

EFFECT OF APERTURE HEATING ON MISSION LIFE FOR THE COLD FOREBAFFLE CONFIGURATION

In an earlier section of this report it was explained why the reference configuration (forward baffle attached to IVCS) was insensitive to aperture heating. It is only included here for comparison purposes.

Unlike the reference configuration, the cold forebaffle configuration has a direct path (although much attenuated, 10 mW/K) to the MCT by way of the aft baffle. As would be expected for this configuration, life is much more sensitive to aperture heating.

EFFECT OF APERTURE HEATING ON MISSION LIFE FOR COLD FORWARD BAFFLE CONFIGURATION AND REFERENCE CONFIGURATION

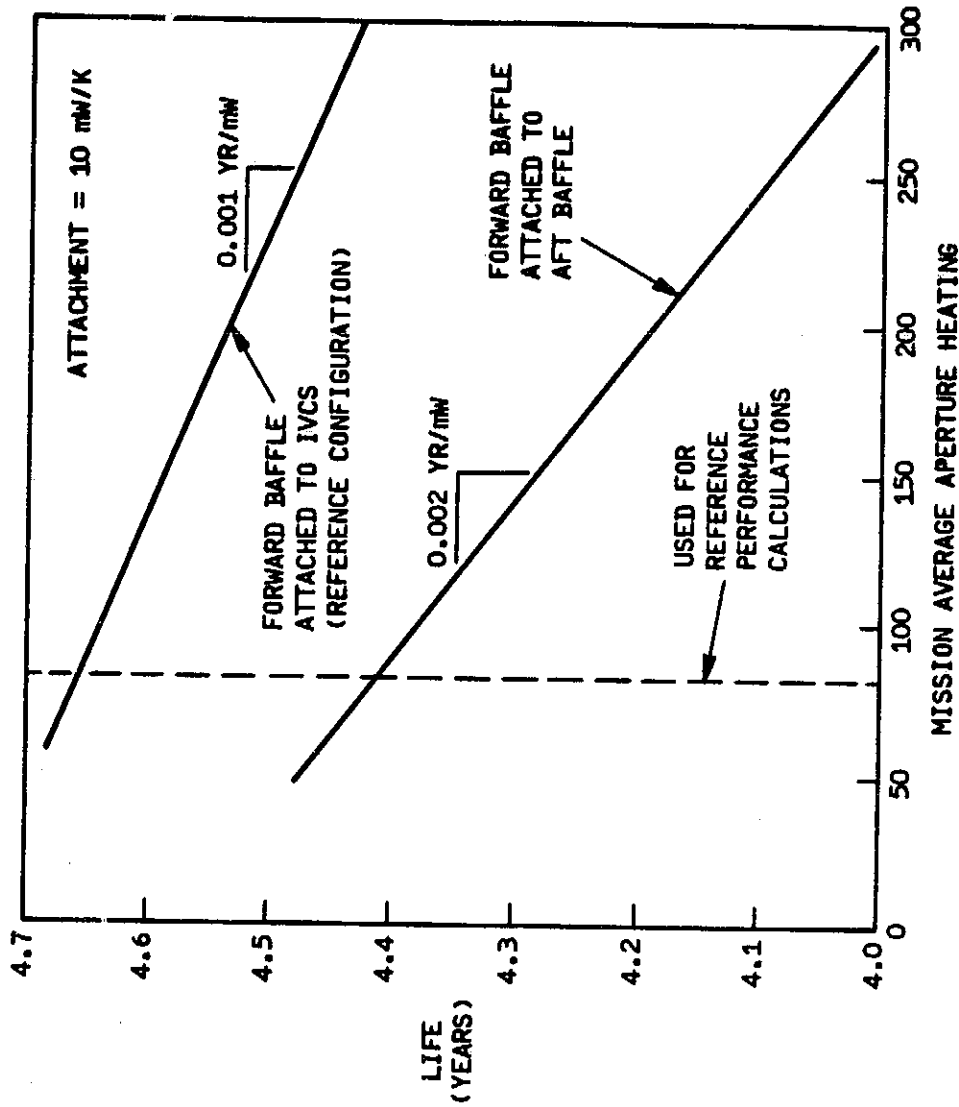

SECTION 5.5

SECONDARY MIRROR COOLDOWN

PRECEDING PAGE BLANK NOT FILMED

THREE DAY SECONDARY MIRROR COOLDOWN IS ACHIEVABLE

The interface conductance between the pivots, mirror and chopper motor housing is the limiting factor on mirror cooldown. At low temperature, 5 to 10 mW/K interface conductance should not be hard to attain. The enclosed data shows that for a constant 5 mW/K approximately 2.5 days are needed for cooldown. In actual fact, this metal to metal interface should be much better than 5 mW/K at higher temperatures and only drop to that value at the end of cooldown.

THREE-DAY SECONDARY MIRROR COOLDOWN IS ACHIEVABLE

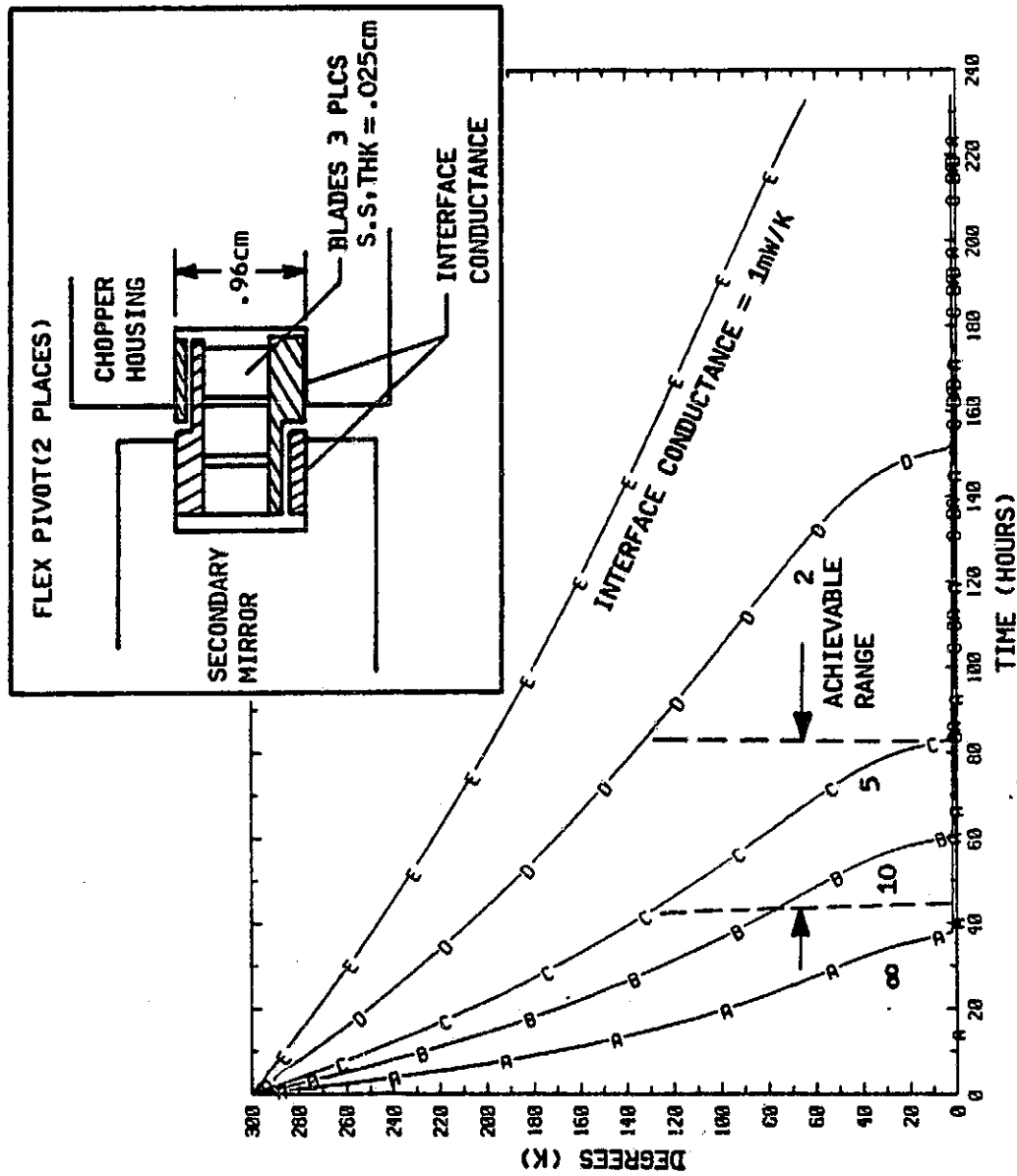

NOTE: ADDITION OF A COPPER STRAP IN PARALLEL WITH THE FLEX PIVOT CAN REDUCE COOLDOWN TIME TO APPROXIMATELY ONE DAY.

SECTION 5.6

**8800 AND 4000
LITER DEWAR COMPARISON**

PRECEDING PAGE BLANK NOT FILMED

PERFORMANCE COMPARISON OF 8800 LITER AND 4000 LITER DEWARs

Two sizes of superfluid helium dewars were evaluated. The first was a 10,000 liter with 12 percent ullage dewar storing 8800 liters of SfHe . This size is representative of the upper limit which may be considered for SIRIF. The minimum size listed in the requirements was 4000 liters, so it was also analyzed. The performance is as stated in the comparison table. Note that either system fulfills the life-time requirement of 2 years. The forward baffle for the smaller system is 1°K warmer. This is due to the reduced 6He coolant flow which is the result of reduced parasitics with the smaller system. An interesting option is to use 4 vapor cooled shields which increases the 8800 liter dewar life-time to 5.8 years and the 4000 liter dewar to 3.2 years.

PERFORMANCE COMPARISON OF THE 8800 AND 4000 LITER SYSTEMS FOR 28.5° AND 98° MISSIONS

	8800 LITER		4000 LITER	
	28.5°	98°	28.5°	98°
OUTER SHELL - K	196	196	196	196
OVCS - K	107	107	106	106
MVCS - K	55	55	53	53
IVCS - K	29	28	27	26
FORWARD BAFFLE - NOM	10.5	9.2	11.4	9.9
FORWARD BAFFLE - PEAK	14.5	--	16.1	--
AFT BAFFLE - K	1.8	1.8	1.8	1.8
SECONDARY MIRROR - K	2.3	2.3	2.4	2.4
PRIMARY MIRROR - K	1.9	1.9	1.9	1.9
APERTURE HEATING (Mission Average)	83	13.5	83	13.5
GH ₂ FLOW - mg/sec*	8.7	8.6	7.1	7.0
LIFE - YEARS*	4.66	4.74	2.59	2.63
DEWAR WEIGHT - Kg	3800		2900	
SIZE:				
• DIAMETER - cm	285		240	
• LENGTH - cm	600		560	

*LIFETIME MEETS OR BEATS REQUIREMENT WITH SFH₆ SYSTEM

NOTE
FOR EITHER 28.5° OR 98° MISSION THE SAME DEWAR IS USED;
ONLY THE SUNSHADE IS CHANGED

SECTION 5.7

CONFIGURATION OPTIMIZATION

A/N 4742

143

PRECEDING PAGE BLANK NOT FILMED

THERMAL DESIGN OPTIMIZATION

Since mission and performance requirements are not now firm, it was decided in general that sensitivity data, not optimized designs, were appropriate for this study. However, two design parameters were investigated for optimization. First, VCS spacing was optimized for four different configurations. Second the 8800 liter outer shell size was reduced both in length and diameter to 240 cm dia x 560 cm length.

The results were that for the three cases investigated, system life can be improved. For the reference configuration life was increased 0.7 years, for the smaller dewar configuration 0.2 years, and for the very long life configuration 0.5 years.

THERMAL DESIGN OPTIMIZATION

- ALL CONFIGURATIONS STUDIED WERE NOT THERMALLY OPTIMIZED
- OPTIMIZATION OF OUTER SHELL SIZE AND VCS LOCATION CAN INCREASE LIFE

CONFIGURATION	BASIC (YEARS)	OPTIMIZED (YEARS)
REFERENCE	4.7	5.4
SMALLER DEWAR (4000 LITER)	2.6	2.8
VERY LONG LIFE (4 VCS)	5.8	6.3

OPTIMIZED OUTER SHELL SIZE

An improved cryogenic system configuration reduces the outer shell dimensions for both the 8800 and 4000 liter systems to 240 cm diameter by 560 cm long. The 8800 liter tank is made thinner and longer to fill the annulus between the vacuum shell and the forebaffle. The thermal model revised the vapor cooled shield location to more optimum locations to improve system lifetime performance.

OPTIMIZED OUTER SHELL SIZE

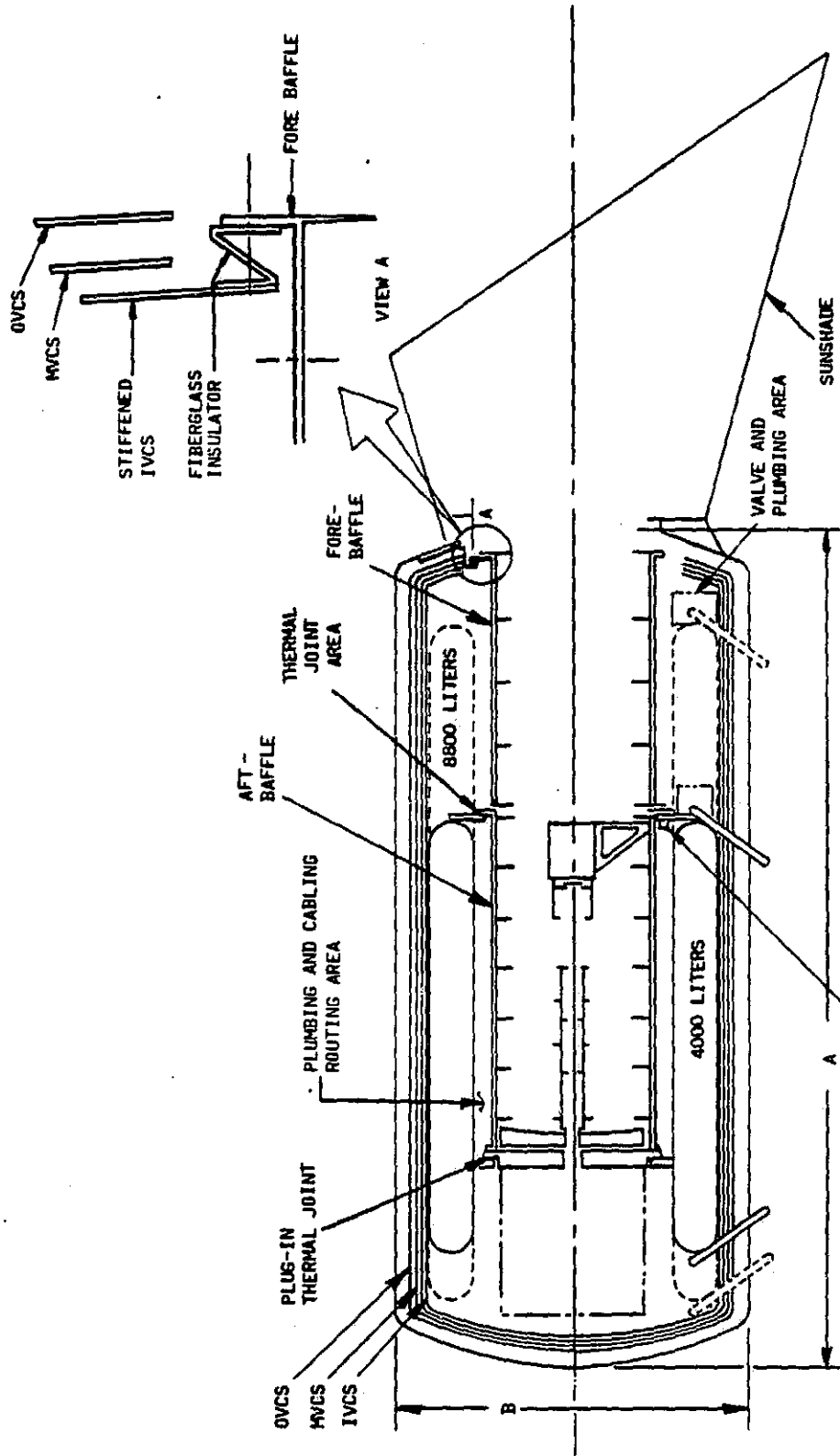

CRYOGEN SYSTEM VOLUME (LITERS)	"A" DIM (cm)	"B" DIM (cm)	SPACECRAFT DIAMETER
8800	560	240	380 cm
4000	560	240	380 cm

SECTION 5.8

**THERMAL ANALYSIS
SUMMARY AND CONCLUSIONS**

PRECEDING PAGE BLANK NOT FILMED

PERFORMANCE OF FOUR CRYOGENIC CONFIGURATIONS

The masses and lifetimes of the four principal all superfluid helium cryogenic configurations studied are summarized here. The reference configuration was developed early in the study as a baseline for the sensitivity analyses. The three alternate configurations explore the impact of designing for very long life, very low forebaffle temperature, or smaller overall size.

PERFORMANCE OF FOUR CRYOGENIC CONFIGURATIONS

	REFERENCE CONFIGURATION ¹	ALTERNATE CONFIGURATIONS		
		VERY LONG LIFE	COLDER FOREBAFFLE	SMALLER DEWAR
CRYOGEN(S) (LITERS): • SUPERFLUID HELIUM	8800	8800	8800	4000
WEIGHT (kg): • DEWAR ONLY • TOTAL SPACECRAFT	3800 5900	3900 6000	3800 5900	2900 5100
LIFETIME ² (YEARS)	4.6	5.8	4.3	2.6

1. USED IN STUDY FOR SENSITIVITY ANALYSIS

2. IN 28.5° ORBIT

THERMAL ANALYSIS CONCLUSIONS

- LIFE IS NOT A STRONG FUNCTION OF APERTURE HEAT LOAD:
 - REFERENCE CONFIGURATION 0.001 YR/mW
 - COLDER FOREBAFFLE CONFIGURATION 0.002 YR/mW

- REDUCED PARASITIC LOAD ON THE MCT COMPENSATES FOR DIRECT HEAT LOAD CHANGES ON THE MCT 0.45 NET mW/mW

- OUTER SHELL TEMPERATURE HAS A LARGE EFFECT ON SYSTEM LIFE 0.029 YR/K

- THE ADDITION OF A FOURTH VCS INCREASES LIFE 25%

- A SUPPORT DISCONNECT SYSTEM CAN INCREASE LIFE OF THE "REFERENCE CONFIGURATION" 9%

THERMAL ANALYSIS CONCLUSIONS (CONTINUED)

- **SECONDARY MIRROR TEMPERATURE IS LESS THAN 2.6K AND EXCURSION IS LESS THAN 0.13K FOR THE TWO MOUNTING SCHEMES ANALYZED**
- **SECONDARY MIRROR COOLDOWN OF LESS THAN THREE DAYS IS ACHIEVABLE**
- **LIFE IN EXCESS OF 5.8 YEARS FOR THE 8800 LITER SYSTEM IS ACHIEVABLE**
- **DESIGN OPTIMIZATION (OUTER SHELL SIZE, VCS SPACING) CAN INCREASE LIFE 10 TO 20%**
- **THERMAL DESIGN OF THE INSTRUMENTS CAN HAVE A LARGE EFFECT ON SYSTEM LIFE AND THE TEMPERATURE OF THE INSTRUMENT'S 7K MIC HEAT SINKS**

SECTION 6.0

DUAL CRYOGEN (SfHe/SH₂)

SYSTEM EVALUATION

PRECEDING PAGE BLANK NOT FILMED

FEATURES OF A DUAL-CRYOGEN SYSTEM

1. Large heat of sublimation of solid H_2 hydrogen requires approximately 500 Joules to vaporize one gram of solid.
2. Thermally attaching the forebaffle to a SH_2 cryogen tank maintains the forebaffle at a fairly constant temperature.

FEATURES OF A DUAL-CRYOGEN SYSTEM

- **HIGH HEAT OF SUBLIMATION OF SOLID H₂**
- **CONSTANT FOREBAFFLE TEMPERATURE**

SFHe/S_H2 CONCEPT FOR SIRTIF

The figure on the opposite page portrays one concept for a hybrid, dual cryogen system which would provide a stable thermal environment for the SIRTIF telescope. It consists of a plug in telescope/MIC assembly which can be completely preassembled external to the dewar. Cooling for the MIC and telescope is provided by bolted joints at the top of the SFHe tank and by a plug-in thermal joint at the bottom. The forebaffle can be mounted to the aft baffle or IVCS through isolated joints with cooling straps to the S_H2 tank or directly attached to the S_H2 tank. A shroud extends from the S_H2 tank surrounding the telescope and MIC but inside the IVCS. The shroud cools the SFHe tank and FGS supports. Surrounding the S_H2 shroud is the insulation system and vapor cooled shields cooled by GHe. The two cryogen tanks are supported from the outer vacuum shell by twelve supports for the SFHe tank and twelve supports for the S_H2 tank.

SfHe/SH₂ CONCEPT FOR SIRTfF

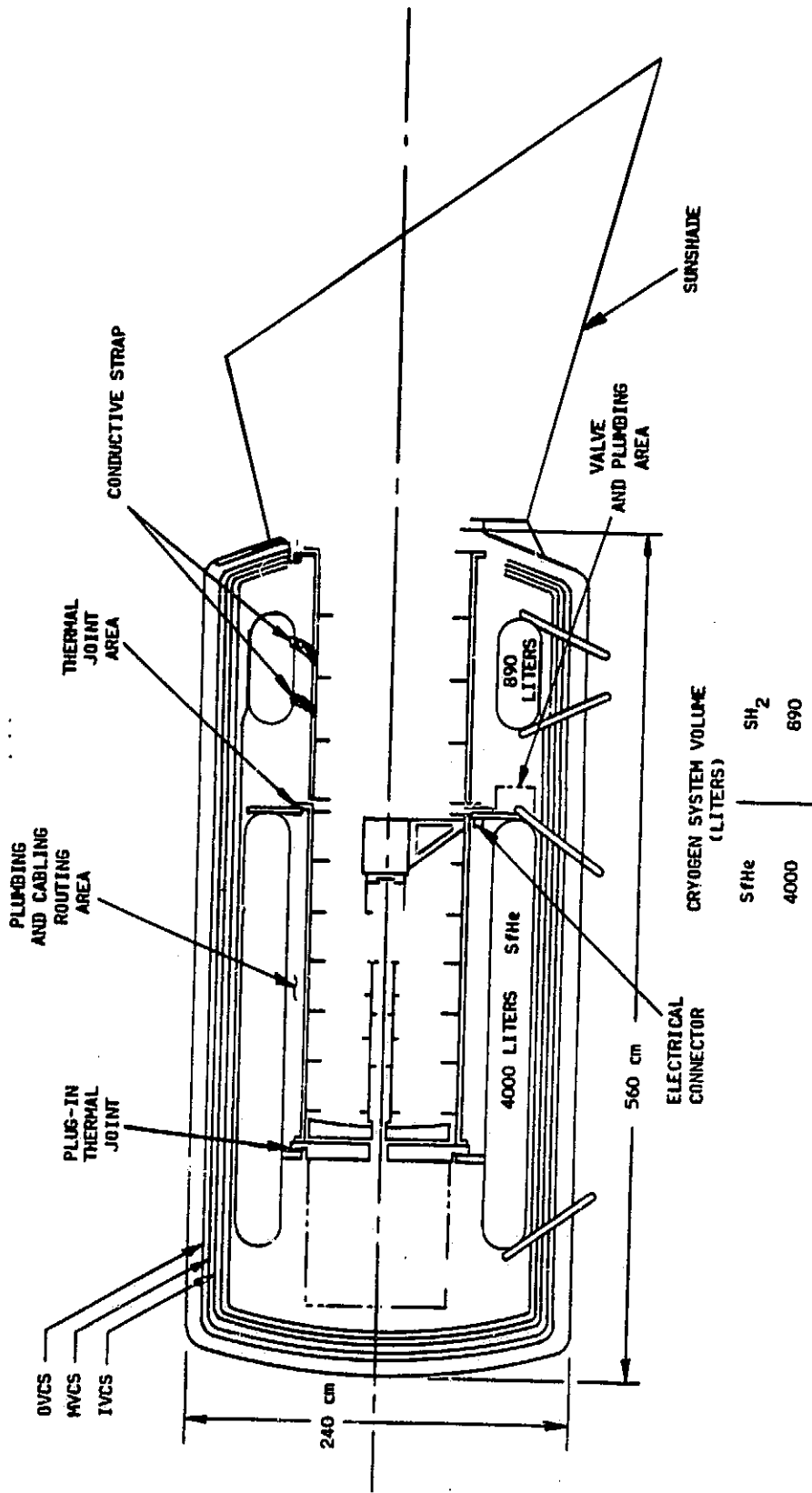

SIRTF DUAL CRYOGEN SYSTEM FLUID MANAGEMENT SCHEMATIC

The dual cryogen system schematic shows both the SfHe system and SH₂ system flow arrangement and components. Those to the right of the dashed line are the additional components for SH₂. Included are fill and vent valves for the LHe cooling lines used to freeze the hydrogen, and fill and vent valves used to fill the hydrogen into the tank.

SIRTF DUAL CRYOGEN SYSTEM FLUID MANAGEMENT SCHEMATIC

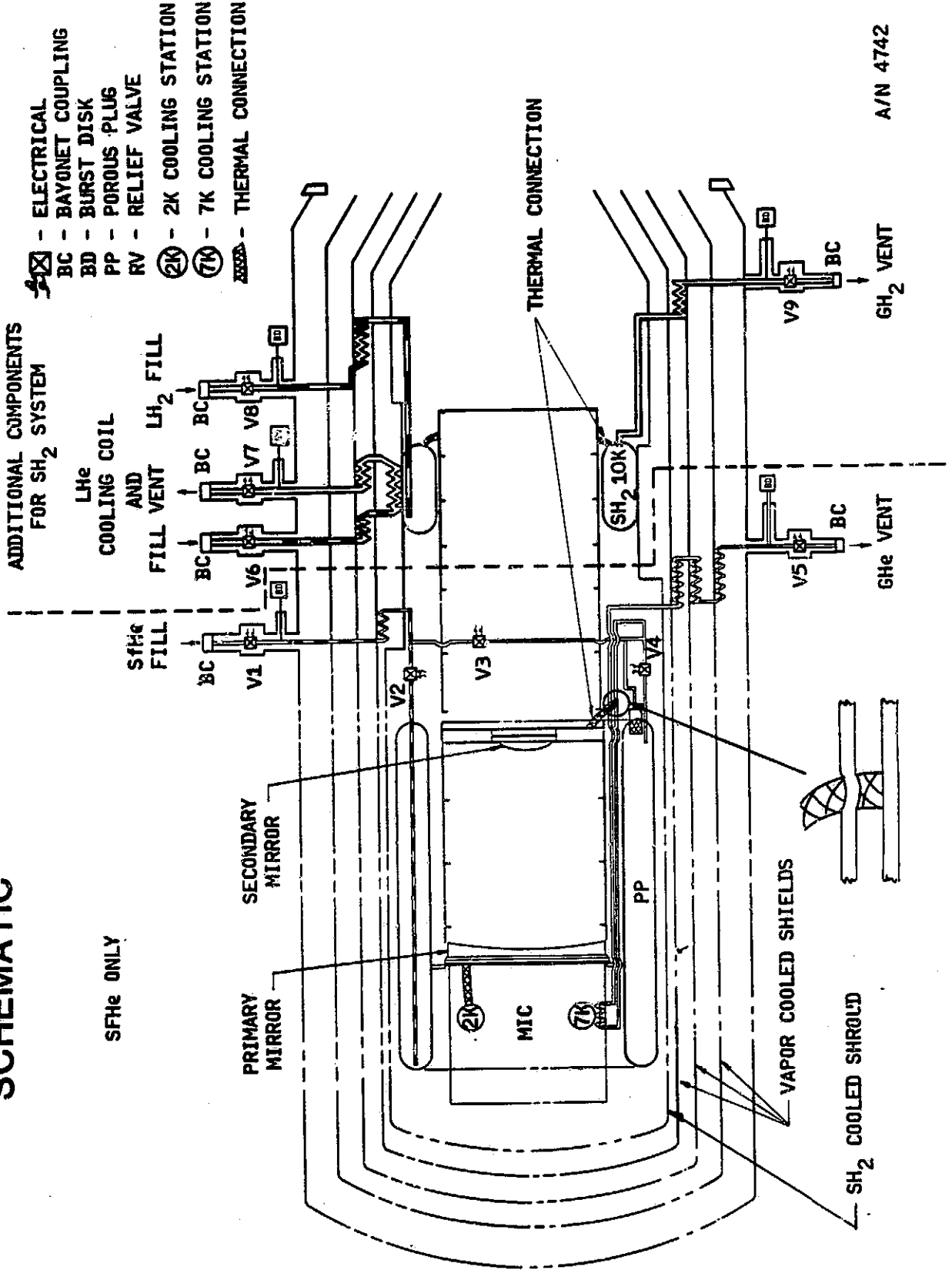

FOUR DUAL CRYOGEN SYSTEM CONFIGURATIONS WERE STUDIED

The dual cryogen system consists of superfluid helium and solid hydrogen cryogenics. The superfluid is used for cooling the MIC, optics, and vapor cooling the insulation system. The solid hydrogen may be used for cooling the forebaffle, IVCS, or extending a shroud around the telescope and MIC assembly which encloses the assembly with a 10K environment.

Life performance was examined for four dual cryogen configurations. For each case, a 4000 liter SFHe tank was used to cool the MIC and optics. The first configuration is for the hydrogen tank attached only to the forward baffle with it's straps not vapor cooled. Life for this case is slightly less than for a 4000 liter all SFHe system. Since aperture heating places only a slight load on the MCT, the solid hydrogen tank saves little. Second, by vapor cooling the hydrogen tank straps and attaching the IVCS to the hydrogen tank, a 0.4 year increase in life-time over the 4000 liter all SFHe, 3 vapor cooled shield system can be achieved, but at the expense of a very large SH₂ tank.

The third configuration utilizes the effluent GH₂ to help cool the middle vapor cooled shield. This reduces the SH₂ tank size by reducing the heat load to the IVCS, but the SH₂ tank is still quite large. The fourth and preferred SH₂ configuration extends a shield from the SH₂ tank around the MIC and telescope inside the GHe vapor cooled shield. The SH₂ cooled shield also cools the support straps and wiring to the SFHe tank. This configuration is more efficient from a system lifetime and weight basis than the other three configurations investigated, but is slightly more complex requiring an additional shield.

DUAL CRYOGEN SYSTEM CONFIGURATIONS STUDIED

HYDROGEN TANK ATTACHED TO:			
	FORWARD BAFFLE BAFFLE ²	FORWARD BAFFLE AND IVCS ⁴	SHROUD SURROUNDING TELESCOPE AND MIC ^{2,5}
	SUPPORTS NOT VAPOR COOLED	SUPPORTS VAPOR COOLED	SUPPORTS VAPOR COOLED
H ₂ LIFE (YEARS)	3.4	3.75	3.75
He LIFE (YEARS)	2.7	3.0	3.1
H ₂ FLOW (mg/sec)	0.44	4.1	0.54
H ₂ WEIGHT (Kg)	47.9 (533 LITER)	488 (5422 LITER)	81 (895 LITER)
FORWARD BAFFLE TEMPERATURE (K) ...	10.1	10.1	10.5
IVCS TEMPERATURE (K)	28.6	13.6	18.6
		410 (4550 LITER)	

NOTES:

1. S_fHe TANK = 4000 LITER
2. ENVELOPE SAME SIZE AS 4000 LITER S_fHe SYSTEM
3. STRAPS WERE RESIZED FOR TANK SIZE
4. ENVELOPE SAME SIZE AS 8800 LITER S_fHe SYSTEM SO AS TO ACCOMMODATE LARGE SH₂ TANK
5. THE RECOMMENDED CONFIGURATION FOR THE DUAL CRYOGEN SYSTEM CONDUCTIVELY COOLS THE FOREBAFFLE, AND SHROUDS THE TELESCOPE AND MIC INSIDE THE IVCS
A/N 4742

**THE IMPACT OF ADDING 895 LITER OF SH₂
TO A 4000 LITER SfHe SYSTEM**

- **INCREASES LIFETIME 19%**
 - **FROM 2.6 YEARS TO 3 YEARS***

- **INCREASES WEIGHT 14%**
 - **FROM 2900 kg TO 3300 kg**

PRECEDING PAGE BLANK NOT FILMED

DUAL CRYOGEN SYSTEM WEIGHT CONSIDERATIONS

1. Over 50% of the heat load to the SFHe comes from the instruments, therefore, the SH₂ can only be used to help reduce the remaining 50% of parasitics and the aperture heat load.
2. The SH₂ replaces effluent GHe used to cool the forebaffle in the dual cryogen system. For an average aperture heating of less than 500 mW and an all SFHe system, only 5 mm of every 100 mm aperture heat load actually reaches the SFHe tank. The major advantage of the SH₂ is a relatively constant forebaffle temperature, not lifetime.
3. The weight is increased by the additional tank, plumbing, and shroud required to contain and control the SH₂ system.

DUAL CRYOGEN SYSTEM CONSIDERATIONS

1. SIRTf CRYOGEN SYSTEM LIFETIME (AND SIZE) IS PRIMARILY DRIVEN BY INSTRUMENT HEAT LOAD INTO THE S_fHe
2. THE SH₂ REPLACES THE EFFLUENT GHe VAPOR COOLING OF THE FOREBAFFLE
3. THE DUAL CRYOGEN SYSTEM REQUIRES AN EXTRA TANK, SHROUD, SH₂, AND CONTROLS WHICH ADD WEIGHT

SECTION 7.0

SINGLE/DUAL

CRYOGEN SYSTEM COMPARISONS

PRECEDING PAGE BLANK NOT FILMED

SINGLE/DUAL CRYOGEN SYSTEM COMPARISON

The three systems compared are the reference configuration (8800 liter), the small dewar (4000 liter), and the dual cryogen system. A 4000 liter SFHe dewar was assumed for the dual system so as to make comparisons easier. The solid hydrogen tank was sized so as to have a 25% life margin over the SFHe lifetime.

For each of the three systems, two different sunshade emissivities were considered: 0.017 (nominal value at 153K) and 0.040 (worst value at 283K).

As would be expected the 8800 liter system yields the longest life 4.7 years. The dual cryogen system has 19% longer life than the 4000 liter SFHe System, i.e., 3.1 vs. 2.6 years respectively. This is due to the interception of much of the MCT parasitics by the SH₂. The instrument load on the MCT (approximately 100 mW) is the same for either system. Mission average aperture heating for an emittance of 0.040 is approximately 2.4 times the value when the emittance is 0.017. For an emittance of 0.040 the dual cryogen system SH₂ tank will have to be enlarged from 890 liter to 2250 liter in order to maintain the same life. If the 890 liter tank is retained, SH₂ life degrades to 1.5 years. For the two SFHe systems 0.2 years of life is given up.

The forebaffle temperature for the SFHe systems are dependent on GHe flowrate, aperture heating and mounting schemes. The dual cryogen system is insensitive to all of these. The forebaffle peak temperature is sensitive to aperture heating for the SFHe system. However, the nominal and minimum temperature are relatively insensitive to aperture heating. (Note that for the colder forebaffle configurations, forebaffle temperature can be reduced approximately 5K for nominal, peak and minimum conditions.)

Secondary mirror temperature is thermally controlled in identical manner for each system so it therefore runs at about the same temperature for each, 2.4K.

The environment and the thermal design is essentially the same for the 8800 liter and 4000 liter systems but the smaller size of the 4000 liter size reduces the parasitic load on the MCT and therefore, the flowrate.

SINGLE/DUAL CRYOGENIC SYSTEM COMPARISONS (28.5° INCLINATION)

ELEMENT	SUNSHADE EMISSIVITY OF 0.017			SUNSHADE EMISSIVITY OF 0.040		
	SfHe	SfHe	SfHe/SH ₂	SfHe	SfHe	SfHe/SH ₂
	1. SIZE OF TANKS - LITERS	8800	4000	4000/890	8800	4000
2. LIFETIME - YEARS	4.7	2.6	3.1/3.8 ¹	4.5	2.4	3.1/3.8 ²
3. FOREBAFFLE TEMPERATURE - K:						
• NOMINAL	10.5	11.4	10.4	12.7	13.5	10.4
• PEAK	14.5	16.1	10.4	20.2	22.0	10.4
• MINIMUM	9.8	9.9	10.4	10.9	11.0	10.4
4. SECONDARY MIRROR TEMPERATURE - K	2.3	2.4	2.5	2.3	2.4	2.5
5. SYSTEM WEIGHT - Kg	3800	2900	3300	3800	2900	3600
6. SATELLITE WEIGHT - Kg	5900	5100	5500	5900	5100	5800
7. FLOW RATE - mg/sec	8.7	7.1	5.9/0.67	9.0	7.5	5.9/1.69

1. SH₂ SIZED FOR A 25% MARGIN OVER THE LHe TO ENSURE LHe RUNS OUT LAST.
2. IF 890 LITER SH₂ TANK IS USED, SH₂ LIFE IS 1.5 YEARS.

SYSTEM COMPLEXITY COMPARISON

The facing page shows the number of components which probably will be included in each type of system. The specific number (especially instrumentation) will be a function of the detail system requirements.

SYSTEM COMPLEXITY COMPARISON

COMPONENT	QUANTITY	
	SINGLE CRYOGEN	HYBRID
CRYOGEN TANK	1	2
VENT LINE	1	2
FILL LINE	1	2
COOLING COIL	0	1
VALVES	5	9
BURST DISKS	2	4
LOW THRUST VENTS	2	4
PRESSURE TRANSDUCERS	2	4
FLOWMETER	1	2
LIQUID LEVEL SENSORS	2	4
TEMPERATURE SENSORS	30	40
SUPPORTS	12	24

CRYOGENIC GSE REQUIREMENTS

The facing sheet presents the cryogenic GSE required to support the two SIRTF cryogenic system concepts. The recommended SHe GSE is based on the IRAS GSE and is the same for both the single cryogen and dual cryogen systems. The SH₂ GSE is based on requirements to fill LH₂ into the tank and then freeze it either with LHe circulating through a cooling coil or by reduction of the pressure over the LH₂. Safety devices for use with the hydrogen operations are also included.

CRYOGENIC GSE REQUIREMENTS

SFHe SYSTEM

LHe LOADING SYSTEM:

- 2 SUPPLY DEWARs
- 2 TRANSFER LINES
- CONTROL STATION

SFHe TOPOFF:

- 2 LARGE CAPACITY VACUUM PUMPS
- 2 FLUID DISTRIBUTION MODULES AND HEAT EXCHANGERS

VACUUM:

- HIGH VACUUM STATION
- LEAK DETECTOR

MISCELLANEOUS:

- GHe LINES
- GHe WARM UP HEAT EXCHANGER

SFHe/SH₂ SYSTEM

LHe LOADING SYSTEM:

- 2 SUPPLY DEWARs
- 2 TRANSFER LINES
- CONTROL STATION

SFHe TOPOFF:

- 2 LARGE CAPACITY VACUUM PUMPS
- 2 FLUID DISTRIBUTION MODULES AND HEAT EXCHANGERS

VACUUM:

- HIGH VACUUM STATION
- LEAK DETECTOR

MISCELLANEOUS:

- GHe LINES
- GHe WARM UP HEAT EXCHANGER

SH₂ (ALL EQUIPMENT EXPLOSION-PROOFED)

LH₂ LOADING:

- 2 SUPPLY DEWARs
- 2 TRANSFER LINES
- FLAME ARRESTOR
- GH₂ SENSOR
- CONTROL STATION

HELIUM COOLING SYSTEM:

- 2 SUPPLY DEWARs
- 2 TRANSFER LINES

VACUUM SYSTEM:

- 1 VACUUM PUMP
- METAL EXHAUST LINES

GSE/FACILITY CONSIDERATIONS

SfHe ONLY SYSTEM

1. BASIC TECHNOLOGY, TYPES OF GSE AND OPERATING PROCEDURES WERE VERIFIED ON IRAS AND WILL BE VERIFIED AGAIN ON COBE.
2. FACILITIES CAN BE STANDARD CLEAN ROOM ENVIRONMENT.
3. CRYOGEN ON-ORBIT REPLENISHMENT SYSTEM WILL REQUIRE ONE FLIGHT QUALIFIED STORAGE AND TRANSFER SYSTEM.

SfHe/SH₂ SYSTEM

1. TWO COMPLETE SETS OF CRYOGENIC GSE ARE REQUIRED. SfHe GSE DESIGN IS ESTABLISHED, SH₂ GSE DESIGN TO BE DEVELOPED ON UARS CLAES PROGRAM
2. IF SATELLITE IS TO BE OPERATED IN A FLIGHT CONFIGURATION DURING GROUND TEST, SH₂ AND SfHe GSE MUST BE EXPLOSION PROOFED. (COST AND OPERATIONAL CONSTRAINTS.)
3. IF SATELLITE IS GROUND TESTED USING LHe IN SH₂ TANKS, AND SH₂ IS USED ONLY IN ORBIT, ONLY THE SH₂ GSE AND HAZARDOUS LOADING FACILITIES MUST BE EXPLOSION-PROOFED.
4. IF SH₂ ACHIEVED BY VACUUM PUMPING, TOTAL CRYO GSE MUST BE EXPLOSION-PROOFED.
5. ON-ORBIT REPLENISHMENT REQUIRES DEVELOPMENT OF TWO FLIGHT QUALIFIED STORAGE AND TRANSFER SYSTEMS.
6. STS GRYOGENIC GSE SPACE IS TIGHT ON LAUNCH TOWER FOR SfHe ALONE AND WILL BE A MORE SEVERE PROBLEM FOR DUAL CRYOGEN SYSTEM GSE.

PRECEDING PAGE BLANK NOT FILMED

SECTION 8.0

STUDY CONCLUSIONS

AND PHASE B RECOMMENDATIONS

A/N 4742

OVERALL STUDY CONCLUSIONS

1. The same superfluid helium cryogenic system design can be used for either a 98° or 28.5° orbit. The self-regulating characteristic of its vapor cooling system makes its lifetime essentially insensitive to aperture heat load. The sunshade design will be different for each orbit.
2. The dominant design driver for the cryogenic system lifetime is the power dissipation of the scientific instruments at the focal plane. The thermal conductance between the 2K and 7K stations within each instrument significantly affects the overall system performance, and must therefore be carefully controlled during the instrument development.
3. Transients in aperture heat load during the sun-avoidance maneuvers required in 28.5° orbit do not seriously disturb the temperatures of the optical subsystem or the focal plane instrument in an all SFHe system.
4. Truncated-cone designs were selected for the sunshades for both orbits because full-cone designs gave unacceptably high aperture heat loads.
5. An orbital maneuvering vehicle (OMV) will be needed to achieve 700 km altitude at either 28.5° or 98° inclination, but should be able to handle the total satellite mass for any of the design options considered.
6. An all SFHe 8800 liter dewar provides a lifetime in excess of 5 years using flight proven existing technology.
7. The 98° orbit permits the cryogenic system to provide the coldest, most stable and longest lifetime environment for the scientific instruments and telescope facility.
8. An all SFHe system can provide forebaffle temperatures as low as 5K for either the 98 or 28.5° orbits.
9. The dual cryogen system provides a nearly constant forebaffle temperature (approximately 10K) for all viewing scenarios.
10. A dual-cryogen system offers a slight lifetime advantage over that of an all-superfluid helium system of the same weight. The dual-cryogen system is more complex than the single-cryogen system in terms of flight hardware, ground support equipment required, and launch operations.
11. Should aperture heat loads on the forebaffle be significantly greater than predicted in the study, combined with a 10-12K temperature requirement at all times for the forebaffle, than a dual cryogen system would be recommended for the 28.5° orbit.

RECOMMENDATIONS FOR CRYOGENIC SYSTEMS PHASE B EMPHASIS

1. PRIOR TO PHASE B:
 - ESTABLISH INTERFACES FOR SCIENTIFIC INSTRUMENT ENVELOPES, AND REQUIREMENTS
 - THERMAL
 - STRUCTURAL
 - ELECTRICAL
 - OPTICAL
 - ESTABLISH SECONDARY MIRROR AND FOREBAFFLE TEMPERATURE REQUIREMENTS
2. DURING PHASE B:
 - PREPARE A PRELIMINARY DEWAR SYSTEM LAYOUT FOR DETAIL THERMAL PATH, CONDUCTANCE, ETC., IDENTIFICATION
 - PREPARE THERMAL AND STRUCTURAL ANALYSIS TO VERIFY FEASIBILITY OF THERMAL AND STRUCTURAL REQUIREMENTS AND INTERFACES
 - UPDATE CRYOGENIC GSE REQUIREMENTS
 - EXAMINE LAUNCH TOWER INTEGRATION OPERATIONS