

## **General Disclaimer**

### **One or more of the Following Statements may affect this Document**

- This document has been reproduced from the best copy furnished by the organizational source. It is being released in the interest of making available as much information as possible.
- This document may contain data, which exceeds the sheet parameters. It was furnished in this condition by the organizational source and is the best copy available.
- This document may contain tone-on-tone or color graphs, charts and/or pictures, which have been reproduced in black and white.
- This document is paginated as submitted by the original source.
- Portions of this document are not fully legible due to the historical nature of some of the material. However, it is the best reproduction available from the original submission.

**NASA Technical Memorandum 86908**

(NASA-TM-86908) EXPERIMENTAL COMPLIANCE

N85-16205

CALIBRATION OF THE NASA LEWIS RESEARCH

CENTER MODE 2 FATIGUE SPECIMEN (NASA) 11 p

HC A02/HF A01

CSSL 20K

Unclas

63/39

13104

# **Experimental Compliance Calibration of the NASA Lewis Research Center Mode II Fatigue Specimen**

**Robert J. Buzzard**  
*Lewis Research Center*  
*Cleveland, Ohio*

Prepared for the  
Eighteenth National Symposium on Fracture Mechanics  
sponsored by the American Society for Testing and Materials  
Boulder, Colorado, June 24-27, 1985

**NASA**



EXPERIMENTAL COMPLIANCE CALIBRATION OF THE NASA LEWIS  
RESEARCH CENTER MODE II FATIGUE SPECIMEN

Robert J. Buzzard  
National Aeronautics and Space Administration  
Lewis Research Center  
Cleveland, Ohio 44135

SUMMARY

Calibration of the NASA Lewis Research Center Mode II fatigue specimen was performed experimentally to provide displacement and stress intensity coefficients over crack length to specimen width ratios ( $a/W$ ) of 0.5 to 0.9. Displacements were measured both at the specimen notch mouth and at the intersection of the notch with the centerline of the loading pin holes.

INTRODUCTION

A Mode II fatigue and fracture specimen has been developed at NASA Lewis Research Center for potential application to aircraft bearing race design (ref. 1). Mode II refers to the edge sliding mode of crack displacement (ref. 2). Primary to the development of this type of specimen is a definition of its stress intensity coefficients over a range of crack length to specimen width ratios. The objective of the present work was to obtain these coefficients through a compliance calibration of the specimen. Such calibration is an established procedure for determining stress intensity coefficients (refs. 3 to 5).

NOMENCLATURE

a crack length  
B specimen thickness  
d loading pin hole diameter  
E Young's modulus of elasticity  
H specimen arm width  
K<sub>II</sub> Mode II stress intensity factor  
L specimen length  
P applied end load  
V displacement along loading axis  
W specimen width  
Y<sub>II</sub> Mode II stress intensity factor coefficient

E-2398

## SPECIMENS

The specimen design used in this study was described in reference 1 and is shown in figure 1(a). Compliance calibration models of the specimen were made from 3.18 mm (1/8 in) thick 7075-T6 aluminum sheet with a reported modulus in tension of  $71.66 \times 10^3$  MN/m<sup>2</sup> ( $10.4 \times 10^6$  psi). The notch representing a crack was made using a band saw. The resulting 0.51 mm (0.020 in) wide slot was finished at the tip to a vee configuration using a hack saw blade ground to that shape. Loading pins were ground to fit tightly into the 12.7 mm (0.500 in) diameter loading holes. Dimensions given in figure 1 are for two specimen sizes. Loading pin hole sizes are identical for both specimen sizes but specimen proportions are slightly different. The smaller design reduced the rotational moment on loading and is therefore a stiffer specimen.

## DISPLACEMENT MEASUREMENT

Displacement measurements were performed by use of a clip gauge (ref. 3) attached to the specimen at the notch mouth, as shown in figure 2, and by photographic observation of a fine scribe line located where the loading pins' horizontal centerline intersects the notch (fig. 2(b)). The scribe line was applied using the precision scribing device, described in reference 6, attached to a machinist's microscope. The photographic method was used only for the smaller specimen's calibration.

## TEST PROCEDURE

The displacement gauge was calibrated over the applicable range for each test run. Displacement calibrations were made using an extensometer calibrator reading to a least division of 0.00127 mm ( $5 \times 10^{-5}$  in). The 44.5 kN (10-kip) load cell used was initially calibrated using dead weight loading and subsequently checked by use of a calibrating resistor.

Load versus displacement slopes were recorded on an x-y recorder. Several slope determinations were made for each crack length. The specimen's notch width was checked using a feeler gauge with the specimen at zero load and while under load to assure that no spreading or closure of the notch occurred as a result of side forces resulting from the application of the load. The maximum load for each series was such that the load versus displacement trace was well within the linear range for each crack length.

After the autographic test run series was completed for each crack length, the previously described scribe line zone was photographed with the specimen at zero load and at 890 N (200 lb) increments of loading. A final photograph was taken after unloading from the maximum load for each series. A microscope equipped with a camera was used. Photographs were taken at a magnification of 26.4X. Measurements on the photographs were performed with a machinist's microscope whose table was translated by means of a vernier calibrated in 0.0025 mm (0.0001 in) increments. The magnification of each photograph was verified by measuring between fiducial marks scribed onto the specimen near the load line reference marks. The notch width at this zone was also verified photographically. Load line displacements for each load were measured as relative displacement of the scribed reference marks along the axis of loading as represented in figure 2(b). The zero load displacement was checked using

the pre-test and post-test photographs, to ascertain that no discernible plastic deformation had occurred during loading.

#### DATA ANALYSIS

Load versus displacement slope determinations were obtained from the x-y recorder test records. For each crack length the slope measurements were averaged. In all cases, the maximum variation in slope measurements was always less than 1.1 percent.

Photographic data points were plotted for each crack length, and a least squares best fit was determined for each.

The resulting slopes were used to obtain EVB/P values, which are tabulated as a function of  $a/W$  in table I and are plotted in figure 3. A least squares third degree polynomial was used to correlate each set of EVB/P versus  $a/W$  data. The coefficients for each data set are listed in table II.

A stress intensity coefficient ( $Y_{II}$ ) was determined from the derivatives of the polynomial of EVB/P as a function of  $a/W$ , where

$$Y_{II} = \left[ \frac{1}{2} a/W \frac{d \frac{EVB}{P}}{d \frac{a}{W}} \right]^{1/2}$$

The  $Y_{II}$  values are related to the stress intensity factor ( $K_{II}$ ) by the relationship.

$$K_{II} = Y_{II} \frac{P}{Ba^{1/2}}$$

The values of  $Y$  at 0.1 increments of  $a/W$  are given in table III and are plotted in figure 4 for each specimen case, and the coefficients of the least squares best fit polynomial - in this case, a second degree polynomial - are presented in table IV.

#### REFERENCES

1. Buzzard, R.J.; Gross, B.; and Srawley, J.E., "Mode II Fatigue Crack Growth Specimen Development," NASA TM-33722, National Aeronautics and Space Administration, Washington, D.C., Aug. 1984.
2. Paris, P.C. and Sih, G.C., "Stress Analysis of Cracks," in Fracture Toughness Testing and Its Applications, STP 381, American Society for Testing Materials, Philadelphia, 1964, pp. 30-81.
3. Bubsy, R.T.; Fisher, D.M.; Jones, M.H.; and Srawley, J.E., in Experimental Techniques in Fracture Mechanics, A.S. Kobayashi, Ed. Iowa State University Press, Ames, IA, 1973, pp. 76-95.

4. Fisher, D.M. and Buzzard, R.J., "Comparison Tests and Experimental Compliance Calibration of the Proposed Standard Round Compact Plane Strain Fracture Toughness Specimen," NASA TM-81379, National Aeronautics and Space Administration, Washington, D.C., Nov. 1979.
5. Fisher, D.M. and Buzzard, R.J., "Experimental Compliance Calibration of the Compact Fracture Toughness Specimen," NASA TM-81665, National Aeronautics and Space Administration, Washington, D.C., Dec. 1980.
6. Buzzard, R.J., "Precision Scriber," NASA Tech Briefs Vol. 4, No. 4, Winter 1979, p. 563.

TABLE I. - EXPERIMENTALLY DETERMINED COMPLIANCE VALUES  
FOR MODE II SPECIMENS

Crack length to specimen width ratio, a/W	Dimensionless compliance, EVB/P		
	For smaller specimen		For larger specimen
	By clip gauge	By photography	By clip gauge
0.497	5.04	4.65	-----
.500	-----	-----	3.93
.549	5.64	5.29	-----
.600	6.44	6.06	5.22
.650	6.89	6.55	5.58
.697	7.61	7.20	-----
.701	-----	-----	6.52
.750	8.54	8.07	-----
.756	-----	-----	7.32
.800	9.35	9.24	8.02
.848	-----	-----	9.09
.850	10.39	10.17	-----
.898	11.86	11.47	-----
.900	-----	-----	10.25

TABLE II. - COEFFICIENTS OF THIRD DEGREE POLYNOMIALS<sup>a</sup> FIT TO  
EXPERIMENTAL COMPLIANCE DETERMINATIONS FOR  
MODE II SPECIMENS

Specimen and method	Coefficient values			
	A	B	C	D
Smaller specimen (clip gauge)	-14.870	81.891	-116.665	65.202
Smaller specimen (photography)	-8.606	51.647	-71.946	43.802
Larger specimen (clip gauge)	-6.987	40.442	-54.04	33.774

$${}^a\text{EVB/P} = A + B(a/W) + C(a/W)^2 + D(a/W)^3.$$

TABLE III. - STRESS INTENSITY COEFFICIENT ( $Y_{II}$ ) FOR  
MODE II SPECIMENS

Crack length-to-specimen width	Stress intensity coefficient, $Y_{II}$ <sup>a</sup>		
	For smaller specimen		For larger specimen by clip gauge
	By clip gauge	By photography	
0.5	1.88	1.77	1.71
.6	1.92	1.95	1.90
.7	2.25	2.32	2.25
.8	2.86	2.87	2.74
.9	3.70	3.59	3.37

$$aY_{II} = K_{II} B a^{1/2}/p.$$

TABLE IV. - COEFFICIENTS OF SECOND DEGREE POLYNOMIALS<sup>a</sup>  
FIT TO STRESS INTENSITY VALUES ( $Y_{II}$ )  
FOR MODE II SPECIMENS

Specimen and method	Coefficient values		
	A	B	C
Smaller specimen (clip gauge)	5.626	-14.209	13.411
Smaller specimen (photography)	3.563	-8.117	9.053
Larger specimen (clip gauge)	2.922	-6.080	7.311

$$aY_{II} = A + B(a/W) + C(a/W)^2.$$



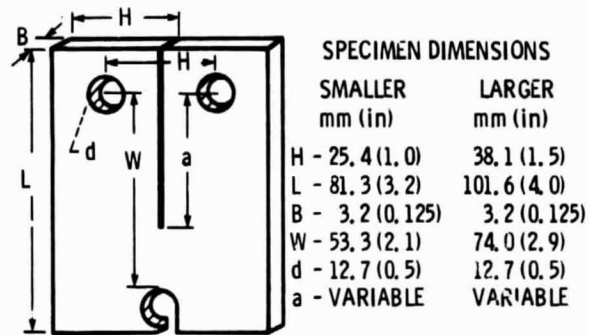

(a) Specimen.

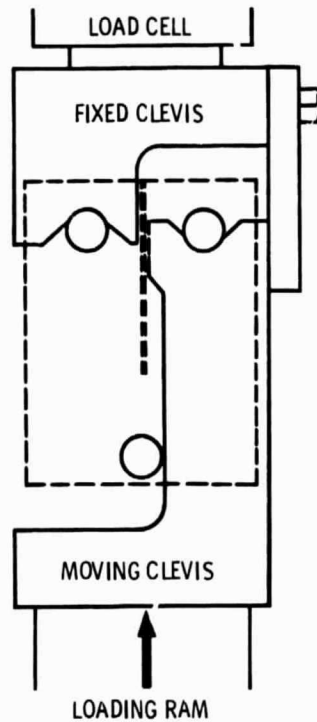

(b) Loading method.

Figure 1. - Mode II test specimen and loading method.

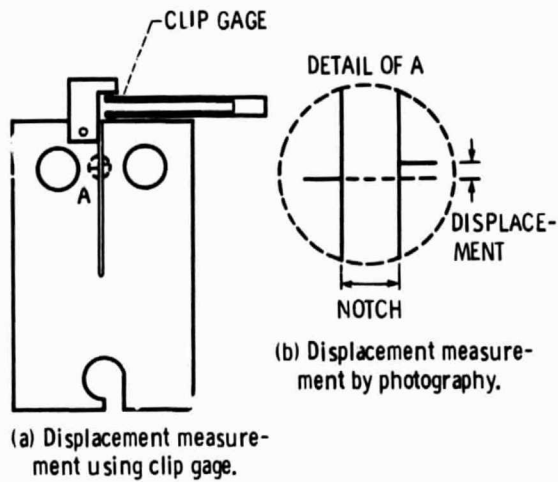

Figure 2. - Displacement measurement methods used to perform Mode II compliance calibration.

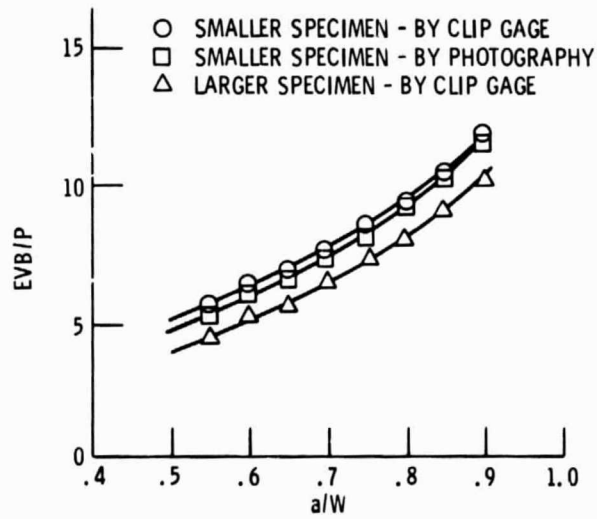

Figure 3. - Experimentally determined compliance values for Mode II specimens.

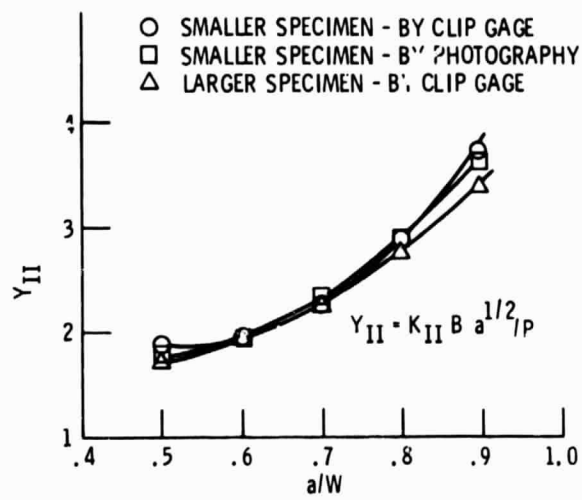

Figure 4. - Stress intensity coefficients ( $Y_{II}$ ) for Mode II specimens.