

NASA Contractor Report 172483

NASA-CR-172483
19850008740

Flight Service Evaluation of Advanced Composite Ailerons on the L-1011 Transport Aircraft

Second Annual Flight Service Report

R.H. Stone

**LOCKHEED-CALIFORNIA COMPANY
BURBANK, CALIFORNIA**

**CONTRACT NAS 1-15069
December 1984**

LIBRARY COPY

FEB 8 1985

LANGLEY RESEARCH CENTER
LIBRARY, NASA
HAMPTON, VIRGINIA

NASA

National Aeronautics and
Space Administration

Langley Research Center
Hampton, Virginia 23665

NASA Contractor Report 172483

**Flight Service Evaluation of
Advanced Composite Ailerons
on the L-1011 Transport
Aircraft**

Second Annual Flight Service Report

R.H. Stone

**LOCKHEED-CALIFORNIA COMPANY
BURBANK, CALIFORNIA**

**CONTRACT NAS 1-15069
December 1984**

NASA

National Aeronautics and
Space Administration

Langley Research Center
Hampton, Virginia 23665

N85-17049#

FOREWORD

This report was prepared by Lockheed-California Company, Burbank, California under Contract NAS 1-15069. It is the second annual report covering flight service evaluation of composite inboard ailerons on the L-1011 from July 1983 when the first yearly inspections were completed through July 1984. The program is sponsored by the National Aeronautics and Space Administration (NASA), Langley Research Center. Mr. Marvin B. Dow is the Project Engineer for NASA.

C. F. Griffin is the Lockheed Engineering Program Manager and is being assisted in the flight service evaluation by R. H. Stone.

Use of commercial products or names of manufacturers in this report does not constitute official endorsement of such products or manufacturers, either expressed or implied, by the National Aeronautics and Space Administration.

FLIGHT SERVICE EVALUATION OF ADVANCED COMPOSITE AILERONS
ON THE L-1011 TRANSPORT AIRCRAFT

SUMMARY

Four shipsets of graphite/epoxy composite inboard ailerons were installed on L-1011 aircraft in March through May 1982 for a five-year maintenance evaluation program. These include two Delta aircraft and two TWA aircraft. A fifth shipset of composite ailerons were installed in 1980 on Lockheed's flight test L-1011.

Results of the second annual inspection of these five shipsets of components are reported herein. These were visual inspections of the aileron exterior surfaces.

No visible damage was observed on any of the composite ailerons, and no maintenance action has occurred on any of the parts except for repainting of areas with paint loss. Flight hours on the airline components at the time of inspection ranged from 6318 to 6989 hours, after approximately two years of service.

1. INTRODUCTION

In 1977 the Lockheed-California Company initiated a program to demonstrate the weight and cost-saving potential of secondary aircraft structures constructed of advanced composite materials. The component selected for this demonstration was the inboard aileron of the L-1011 transport aircraft. The program is sponsored by the National Aeronautics and Space Administration as part of the Aircraft Energy Efficiency (ACEE) Composite Structures Program.

The program scope included the evaluation of alternate designs and materials for the aileron; detail design and analysis; fabrication and test of subcomponents for design verification; fabrication and testing of two ground test ailerons; fabrication of five shipsets of ailerons for installation on L-1011 aircraft; flight testing of one shipset on Lockheed's flight test aircraft; and the 5 year flight service evaluation discussed herein. The overall program is summarized in the executive summary report (Ref. 1). Lockheed's team member on this program was Avco Aerostructures Division of Avco Corporation. Avco was responsible for fabrication of the composite ailerons.

The composite aileron design, shown in Figure 1, is a multirib configuration with single piece upper and lower covers mechanically fastened to the substructure. Three basic materials were utilized in the aileron design: Narmco 5208/T300 graphite/epoxy unidirectional epoxy tape; Narmco 5208/T300 graphite/epoxy bidirectional fabric; and Hysol ADX 819 syntactic epoxy core.

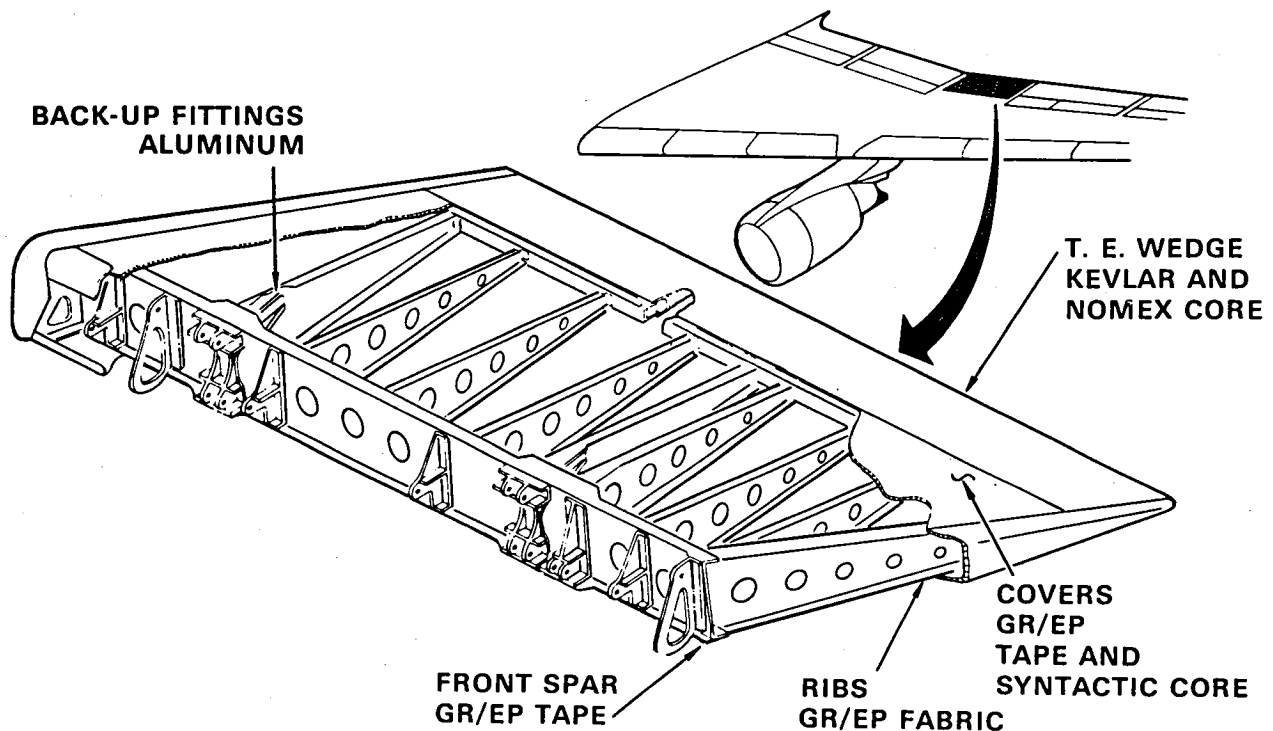

Figure 1. - Advanced composite aileron assembly.

The aileron covers, ribs, and front spar were fabricated using standard vacuum bag autoclave molding procedures. The aileron covers are thin sandwich plates with graphite/epoxy tape facesheets and a syntactic epoxy core. The ribs and spars are constant thickness channel sections, laid up and cured on male tools. The intermediate ribs are fabricated of bidirectional graphite/epoxy fabric. The main ribs which react hinge and actuator loads are fabricated of graphite/epoxy fabric, with the caps reinforced with graphite/epoxy tape. The front spar is fabricated of graphite/epoxy tape laid up in approximately a quasi-isotropic orientation.

The complete aileron assembly includes an aluminum leading edge shroud, aluminum bathtub fittings at the spar to main rib joints, fiberglass/epoxy fairings, aluminum hinge/actuator fittings, and a Kevlar 49/epoxy trailing edge. The composite aileron design is 26% lighter than the metal aileron and is predicted to be cost competitive since the composite aileron has 50% fewer parts and fasteners than the metal aileron.

The inboard aileron is located on the wing trailing edge between the outboard and inboard trailing edge flaps. It is supported from the wing at two hinge points and is actuated by three hydraulic actuators. It is a wedge-shaped, one-cell box, thinning slightly from root to tip. At the front spar the aileron is 233.7 cm. (92 in.) in length and approximately 25.4 cm. (10 in.) deep. The width of the aileron is 127 cm. (50 in.). The upper

surface, ribs, and spars are permanently fastened using titanium Triwing screws and stainless steel Hi-Lok collars. The removable lower surface, trailing edge wedge, and end fairings are attached with the same type screws but with nut plates attached to the structure with A286 Cherry Rivets. All fasteners are installed with sealant. The aileron is primed and painted with standard aircraft materials.

2. FLIGHT SERVICE EVALUATION PLAN

The final phase of the inboard aileron program is a five-year flight service evaluation. A left-hand and right-hand aileron were installed on four new L-1011 aircraft. Two of these aircraft were subsequently delivered to Delta Air Lines, and the two others were delivered to Trans World Airlines. The Delta aircraft were the standard L-1011-1 model, while the TWA aircraft were longer range L-1011-100s.

The evaluation agreement between Lockheed and the two participating airlines consisted of the following elements:

- 1) The evaluation period is five years.
- 2) An exterior visual inspection will be performed by airline personnel and witnessed by Lockheed personnel at annual scheduled "C"-check inspections closest to the anniversary of installation.
- 3) An interior inspection, requiring removal of the lower cover, will be conducted at the end of the five-year evaluation by airline personnel, witnessed by Lockheed personnel.
- 4) The airlines will provide a written report to Lockheed on the results of each inspection. This report will include inspection results, a description of any maintenance or repair actions, flight hours, number of landings, and utilization rate for the year.
- 5) In the event visible damage is observed, the airlines will determine the extent of damage by ultrasonic inspection using standards provided by Lockheed. After notification of Lockheed, the airline will repair the damage in accordance with the L-1011 Structural Repair Manual, which was revised to incorporate specific repair procedures for the composite ailerons.

A fifth shipset of ailerons are being evaluated on the Lockheed flight test airplane. A visual inspection of the exterior and interior aileron surfaces was conducted by Lockheed personnel. The ailerons were originally installed on this aircraft for flight tests as part of FAA certification. These flight tests are described in the Task IV Final Report (Ref. 2).

3. AILERON FLIGHT SERVICE EXPERIENCE

The first annual flight service inspections of the five aileron shipsets were conducted in March through July of 1983. The results of these inspections are given in the First Annual Flight Service Report (Ref. 3) and are summarized in Table I. No damage or defects were observed in any of the ten ailerons in those inspections.

The inspection results for the second year of flight service are summarized in Table II, along with utilization rate and aircraft flight-hours and landings as of the inspection date for the composite ailerons. A total of 53,912 component flight-hours were accumulated through July 20, 1984 on the ten installed ailerons. The high time ailerons have accumulated 6989 flight hours in two years.

The second annual visual inspections of the composite ailerons again revealed no damage, even of a minor nature, on any of the ten components. Minor paint loss was reported on three of the aileron shipsets, and in two instances touch-up paint was applied. Paint loss of this type is a fairly common occurrence on metal or fiberglass components. The significance for the graphite/epoxy ailerons is: 1) paint loss indicates that the ailerons are being exposed to hydraulic fluid; and the lack of damage verifies the resistance of graphite/epoxy to aircraft fluids; 2) the upper surface is exposed to ultraviolet, and epoxy resins are known to be affected by ultraviolet with significant weight losses after extended exposure. Airline maintenance personnel were advised of the need for repainting of exposed graphite/epoxy, particularly on the upper surface.

There were two instances of minor damage to components, which are part of the inboard aileron assembly, but which are not made of graphite composite material. Surface abrasion and delaminations were noted on the fiberglass end closure of the left-hand aileron on Delta Ship N736DY. There were five areas of this condition, about 1.3 cm. (0.5 inch) in diameter. Speed tape was applied as a repair. The other damage condition was missing or damaged lightening hole covers on the aileron front spar, which were noted on all four TWA ailerons. These were replaced with spare covers. These minor damage incidents do not reflect on the graphite aileron serviceability, but are indicative of the potential for in-service damage of this component.

These results indicate that the graphite/epoxy components perform satisfactorily in the high utilization environment of commercial transports. The satisfactory structural performance of the ailerons and the absence of damage or defects verifies the structural and durability data obtained in the composite aileron test program.

TABLE I. - FLIGHT SERVICE SUMMARY - FIRST YEAR

Operator	Aircraft Tail No. (Lockheed Serial No.)	Date of Delivery	Date of Inspection	Flight-Hrs. at Inspection	No. Landings at Inspection	Utilization Rate (Hrs/Day)	Inspection Results
Delta	N736DY (1227)	Mar. 11, 1982	Mar. 28, 1983	3226	1795	8.7	No discrepancies observed on either part
Delta	N737D (1228)	May 8, 1982	Apr. 14, 1983	2885.6	1602	8.6	No discrepancies observed on either part
TWA	N8034T (1230)	Apr. 7, 1982	June 20, 1983	4042	1067	9.8	LH Part: No damage or defects. Minor paint loss noted. RH Part: No damage or defects. Some paint loss; one area 6" x 4" repainted on upper surface.
TWA	N7035T (1231)	Apr. 29, 1982	July 19, 1983	4190	1123	9.7	LH Part: No damage or defects. Minor paint loss noted. RH Part: No damage or defects. Fairly extensive paint loss on lower surface; touch-up paint applied to some of this area.
Lockheed	(1001)	June 3, 1980 	Apr. 22, 1983	340.6	52	0.32	No damage or defects, except paint chipping noted around several fasteners (6-8) on each part.
Totals				14684.2	5639		

 Date of composite aileron installation.

TABLE II. CUMULATIVE FLIGHT SERVICE SUMMARY - SECOND YEAR

Operator	Aircraft Tail No. (Lockheed Serial No.)	Date of Delivery	Date of Inspection	Cum. Ft.-Hrs. at Inspection		Cum. Landings at Inspection		Util. Rate (Hrs./Day)	Inspection Results First Annual Inspection	Inspection Results Second Annual Inspection
				1st Annual Insp.	2nd Annual Inspec.	1st Annual Insp.	2nd Annual Inspec.	Two Yrs. Ft. Svc. Period		
Delta	N736DY (1227)	Mar. 11, 1982	May 8, 1984	3226 / 6634	1795 / 3744	8.4	No discrepancies observed on either part.	No discrepancies observed on either part. Small surface delaminations noted on fiberglass end closure of LH part, and repaired with speed tape.		
Delta	N737D (1228)	May 8, 1982	May 22, 1984	2885.6 / 6318	1602 / 3540	8.5	No discrepancies observed on either part.	No discrepancies observed on either part.		
TWA	N8034T (1230)	Apr. 7, 1982	Apr. 17, 1984	4042 / 6989	1067 / 1814	9.4	LH Part: No damage or defects. Minor Paint loss noted. RH Part: No damage or defects. Some paint loss; one area 6" x 4" repainted on upper surface.	No damage or defects observed on either part. Minor paint loss noted. Parts were repainted; several torn or missing lightening hole covers replaced on front spar.		
TWA	N7035T (1231)	Apr. 29, 1982	Apr. 19, 1984	4190 / 6650	1123 / 1745	9.2	LH Part: No damage or defects. Minor paint loss noted. RH Part: No damage or defects. Fairly extensive paint loss on lower surface; touch-up paint applied to some of this area.	No damage or defects observed on either part. Minor paint loss noted. Parts were repainted; several torn or missing lightening hole covers replaced on front spar.		
Lockheed	(1001)	June 3, 1980 ⚠	July 20, 1984	340.6 / 365	52 / 64	0.24	No damage or defects, except paint chipping noted around several fasteners (6-8) on each part.	No damage or defects, except paint chipping noted around several fasteners (6-8) on each part, as in previous inspection.		
Totals				14,684.2 / 26,956	5639 / 10,907					

⚠ Date of composite aileron installation.

REFERENCES

1. Griffin, C.F. and Dunning, E.G., "Development of An Advanced Composite Aileron for the L-1011 Transport Aircraft," NASA Contractor Report 3517, February 1982.
2. Griffin, C.F., "Advanced Composite Aileron for L-1011 Transport Aircraft - Ground Tests and Flight Evaluation," NASA Contractor Report 165664, February 1981.
3. Stone, R.H., "Flight Service Evaluation of Advanced Composite Ailerons on the L-1011 Transport Aircraft - First Annual Flight Service Report," NASA Contractor Report 172246, September 1983.

1. Report No. NASA CR-172483		2. Government Accession No.		3. Recipient's Catalog No.	
4. Title and Subtitle Flight Service Evaluation of Advanced Composite Ailerons on the L-1011 Transport Aircraft - Second Annual Flight Service Report				5. Report Date December 1984	
				6. Performing Organization Code	
7. Author(s) R. H. Stone				8. Performing Organization Report No. LR 30774	
9. Performing Organization Name and Address Lockheed-California Company P.O. Box 551 Burbank, California 91520				10. Work Unit No.	
				11. Contract or Grant No. NAS 1-15069	
12. Sponsoring Agency Name and Address National Aeronautics and Space Administration Washington, DC 20546				13. Type of Report and Period Covered Contractor Report	
				14. Sponsoring Agency Code 534-06-13-01	
15. Supplementary Notes Langley Technical Monitor: Marvin B. Dow Second Annual Flight Service Report					
16. Abstract <p>This report covers flight service evaluation of composite inboard ailerons on the L-1011 under Contract NAS 1-15069 for a period of five years. This is the second annual report of the maintenance evaluation program, and covers the period from July 1983 when the first yearly inspections were completed, through July 1984.</p> <p>Four shipsets of graphite/epoxy composite inboard ailerons were installed on L-1011 aircraft for this maintenance evaluation program. These include two Delta aircraft and two TWA aircraft. A fifth shipset of composite ailerons were installed in 1980 on Lockheed's flight test L-1011. A visual inspection was also conducted on these components.</p> <p>No visible damage was observed on any of the composite ailerons, and no maintenance action has occurred on any of the composite parts except for repainting of areas with paint loss. Flight hours on the airline components at the time of inspection ranged from 6318 to 6989 hours, after approximately 2 years of service.</p>					
17. Key Words (Suggested by Author(s)) Composites, Graphite/Epoxy, Transport Aircraft, Maintenance, Flight Service			18. Distribution Statement Unclassified - Unlimited Subject Category 24		
19. Security Classif. (of this report) Unclassified		20. Security Classif. (of this page) Unclassified		21. No. of Pages 9	22. Price* A02

