

General Disclaimer

One or more of the Following Statements may affect this Document

- This document has been reproduced from the best copy furnished by the organizational source. It is being released in the interest of making available as much information as possible.
- This document may contain data, which exceeds the sheet parameters. It was furnished in this condition by the organizational source and is the best copy available.
- This document may contain tone-on-tone or color graphs, charts and/or pictures, which have been reproduced in black and white.
- This document is paginated as submitted by the original source.
- Portions of this document are not fully legible due to the historical nature of some of the material. However, it is the best reproduction available from the original submission.

Tribological Properties of Graphite-Fiber-Reinforced, Partially Fluorinated Polyimide Composites

(NASA-TM-86926) TRIBOLOGICAL PROPERTIES OF
GRAPHITE-FIBER-REINFORCED, PARTIALLY
FLUORINATED POLYIMIDE COMPOSITES (NASA)
28 p HC A03/MF A01

NO5-18153

CSCI 11G

Unclas
14102

63/27

Robert L. Fusaro and William F. Hady
Levis Research Center
Cleveland, Ohio



Prepared for the
1985 Annual Meeting of the American Society of Lubrication Engineers
Las Vegas, Nevada, May 6-9, 1985

NASA

TRIBOLOGICAL PROPERTIES OF GRAPHITE-FIBER-REINFORCED,
PARTIALLY FLUORINATED POLYIMIDE COMPOSITES

Robert L. Fusaro and William F. Hady
National Aeronautics and Space Administration
Lewis Research Center
Cleveland, Ohio 44135

ABSTRACT

Graphite-fiber-reinforced polyimide (GFRPI) composites were formulated from three new partially fluorinated polyimides and three types of graphite fiber. Nine composites were molded into pins and evaluated in a pin-on-disk tribometer. Friction coefficients, wear rates, pin wear surface morphology, and transfer film formation were assessed at 25 and 300 °C. Also assessed was the effect of sliding speed on friction at 300 °C and the effect of temperature on friction. Wear was up to two orders of magnitude lower at 25 °C and up to one order of magnitude lower at 300 °C than with previously formulated NASA GFRPI composites.

INTRODUCTION

The need for self-lubricating materials in the aerospace industry is continuously increasing, with ever greater demands being placed on the high-temperature performance of these materials. One class of materials that has shown considerable promise is graphite-fiber-reinforced polyimides (GFRPI) (1-20). They are being considered or being used already in various bearings, gears, seals, or brake materials (9,11-14,18-20).

Polyimide, a high-temperature polymer, provides the matrix for the graphite fibers; the graphite fibers improve the strength and stiffness of the composite while also providing lubrication. The term "polyimide" does not refer to one particular polymer, however, but to a class of long-chained polymers that have repeating imide groups as an integral part of the main chain. By varying the monomeric starting materials, polyimides of different

chemical compositions and structures can be obtained. The polyimide chains consist of aromatic rings alternated with heterocyclic groups. Because of the multiple bonds between these groups the polyimides have high thermal stability and crumble, on decomposition, to a fine powder without melting.

In 1975, a polyimide was formulated from partially fluorinated polyimide resins prepared from the diamine 2,2-bis[4-(4-aminophenoxy)phenyl] hexafluoropropane (4-BDAF) (21) that possessed great potential for long-term service in highly oxidative environments to 370 °C (22,23). Because of the promise shown in the preliminary testing of physical properties two other polyimides were formulated from the 4-BDAF diamine for tribological evaluation: one using the dianhydride of benzophenonetetracarboxylic acid (BTDA), and one using 50 mole percent of BTDA and 50 mole percent of the dianhydride of pyromellitic acid (PMDA). In addition to these solid polyimides, graphite-fiber-reinforced polyimide composites were made from the 50/50 PMDA/BTDA polyimide.

Although good tribological results were obtained for both the solid polyimides and the composite (24), they suggested that high amounts of the PMDA dianhydride in the polyimide would produce polymers with even better tribological properties. The results also showed that graphitic fiber is a better reinforcement than nongraphitic fiber and that the sizing material may have limited the high-temperature stability.

This study extended the results of the previous study (24) to composites made from the 4-BDAF diamine with 60, 80, and 100 mole percent PMDA (BTDA was the other dianhydride component) and graphite fibers. Two additional graphite fibers were evaluated. Thus nine GFRPI composites were formulated and evaluated in this study. To improve the adherence of the polyimides to the fibers and the high-temperature stability of the composites, the sizing

material as applied by the fiber manufacturer was removed and the fibers were sized with the 100 percent PMDA polyimide.

Friction coefficients, wear rates, wear surface morphology, and transfer film formation were studied for the nine GFRPI composite materials (made into hemispherically tipped pins) after they had slid against metallic disks at temperatures of 25 and 300 °C. Friction coefficient as a function of constantly increasing or decreasing temperature was also evaluated.

MATERIALS

New polyimides based on a novel aromatic diamine 2,2-bis[4-(4-aminophenoxy)phenyl] hexafluoropropane (4-BDAF) were formulated with the dianhydrides of benzophenonetetracarboxylic acid (BTDA) and of pyromellitic acid (PMDA) (Fig. 1). One polyimide and two copolyimides were prepared from these components. The polyimide was polymerized from the polyamic acid solution of the monomers of 4-BDAF and PMDA. The copolyimides were prepared by adding the dianhydrides, in the correct proportions, to the 4-BDAF diamine during polymerization. The copolyimides contained 80 percent (by mole) PMDA with 20 percent BTDA and 60 percent PMDA with 40 percent BTDA. Each polyimide contained the 4-BDAF diamine, but for convenience it will not be included in the designations. The designations will be 100 PMDA, 80/20 PMDA/BTDA, and 60/40 PMDA/BTDA. The preparation of the 4-BDAF diamine and the polyimides made from it is described by Jones et al. (22,23).

Three graphite fibers were mixed with these polyimides to make nine composites. The fibers are designated types A, B, and C. Their properties are listed in Table 1. The fibers were sized by their manufacturers with an unknown polyimide. To ensure good adherence of our polyimides and high-temperature stability, these sizings were removed and the fibers were resized with the 100 PMDA polyimide (25).

The polyimide composites were molded into pins 2.0 cm long and 0.95 cm in diameter (25). A 0.476-cm-radius hemisphere was machined on one end. The hemisphere was slid against 440C HT (high temperature) stainless steel (hardness, Rockwell C 60), against the cobalt alloy Haynes 6B (hardness, Rockwell C 44), or against René 41 (hardness, Rockwell C 35). The alloys had the same surface roughness, $10^{-7} R_a$ (arithmetic mean).

APPARATUS

A high-temperature pin-on-disk tribometer was used in this investigation (Fig. 2). The loads were applied through a lever arm. The same lever arm transmitted the friction force to a strain gauge whose output was continuously recorded on a strip-chart recorder. The disks were heated by induction, and the temperature was monitored by a thermocouple when the disk was not rotating and by an infrared optical pyrometer when it was. The friction specimens were enclosed in a chamber to control the atmosphere at 10 000 ppm H₂O (~50 percent relative humidity at 25 °C).

PROCEDURE

Specimen Cleaning

The metallic disks were washed with ethyl alcohol and scrubbed with a water-based paste of levigated alumina. They were then scrubbed with a brush under running distilled water to remove the alumina and dried with clean compressed air.

The polyimide composite pins were scrubbed with a nonabrasive detergent, rinsed with distilled water, and dried with clean compressed air.

Testing

After the pin and disk specimens were inserted into the test apparatus and the chamber was sealed, moist air was pumped into the chamber for 15 min before each test and continuously throughout the test. After purging, the disk was rotated at 100 rpm (0.31 m/s) at 25 °C or 1000 rpm (3.1 m/s) at 300 °C.

For the 300 °C test the disks were slowly heated by induction and held at 300 °C for 10 min to allow the temperature to stabilize. The load (9.8 N) was gradually applied to the rotating disk through the stationary pin, which slid on a 6-cm-diameter track on the disk.

At various times during the experiments the tests were stopped and the specimens removed and examined by optical microscopy. The wear scar on each pin tip was measured and the wear volume calculated. The pin was not removed from the holder, and locating pins ensured that it was returned to its original position in the apparatus.

For the tests in which friction coefficient was determined as a function of constantly increasing or decreasing temperature, the procedure was to run-in the polyimide composite pins under a 9.8-N load at 100 rpm (0.31 m/s) and 25 °C for 30 min. The temperature was gradually increased at 4 deg C/min to 300 °C and then decreased at the same rate to about 100 °C. Below 100 °C the heat was turned off and the disk was allowed to cool at its own rate, which was slower than 4 deg C/min.

RESULTS AND DISCUSSION

Composite Wear Rates

To determine the effect of graphite fiber and polyimide type, a 3-by-3 experimental test matrix was set up using the three graphite fibers as one variable and the three polyimides as the other variable. Thus nine GFRPI composites were evaluated. The GFRPI composites were molded into pins and slid against metallic disks. No wear was observed on the metallic disks, but the GFRPI composites wore in a linear manner after progressing through a run-in regime that decreased exponentially. Most of the run-in wear occurred in the first 33 m of sliding (Table 2). Slightly lower run-in wear rates were obtained with the type C fiber and with the 80/20 PMDA/BTDA polyimide, although the differences were not great.

A 9.8-N load was applied to the hemispherically tipped pins. If this were rolling contact, a very high Hertzian stress would have resulted. But in sliding contact a flat area is almost immediately worn on the hemisphere, and this reduces the Hertzian stress. The contact area on each pin was measured after 33 m of sliding, and the contact stresses were calculated for 100 percent contact (Table 3). The contact stress s ranged from 91 to 57 MPa (13 200 to 8900 psi), although this is by no means the maximum load-carrying capacity for these composites.

After run-in, wear tended to increase linearly, although in a few instances the rate changed after a period of sliding. The greatest wear rate change was that of the 80/20 PMDA/BTDA polyimide with the type C fiber (Fig. 3). We believe that the wear rate changed because the transfer characteristics changed. Usually lower wear occurs when thin, flowing transfer films are formed, and higher wear occurs during thick, "nonflowing" transfer.

The slopes of the lines in Fig. 3 were determined by taking a linear regression fit (least squares) to get wear rate in terms of wear volume per unit distance of sliding (m^3/m) (see also Table 4). Three composites had slightly higher wear rates than the average: 100 PMDA with type B fibers, 80/20 PMDA/BTDA with type C fibers, and 60/40 PMDA/BTDA with type A fibers. Composite 60/40 PMDA/BTDA with type B fibers had the lowest wear rate, $0.04 \times 10^{-15} m^3/m$. Although we thought this was an anomaly, it was repeatable, as were the higher wear rates. Even so, the differences may be due not to the materials but to unknown processing variables. These materials are by no means optimized.

The type of fiber had little influence on the steady-state wear rates, but the 60/40 PMDA/BTDA polyimide appeared to be a better matrix material at 25 °C (Table 4). The wear rate results were an order of magnitude lower than

the $1.5 \times 10^{-15} \text{ m}^3/\text{m}$ obtained in our preliminary study (24) for a composite of 100 percent BTDA polyimide and type B fibers (designated type HG in that study).

Similar experiments were conducted at 300 °C, but at a higher sliding speed (1000 rpm; 3.1 m/s) and with René 41 and Haynes 6B instead of 440C HT stainless steel. These alloys were used because 440C tended to oxidize at 300 °C and this increased the wear rate. Oxidation appeared to be less with René 41 and Haynes 6B.

Three tests were conducted for each composite sliding against each alloy, for a total of six tests on each composite. Little difference in composite wear rates was found for the three polyimides (Table 5), although the type A fibers did produce slightly higher wear rates. Also the disk material, René 41 or Haynes 6B, had little effect on wear rate. It is an interesting fact that the 80/20 PMDA/BTDA polyimide without any graphite fiber additions produced an equivalent wear rate (Table 5).

Friction Coefficient

At 25 °C, on 440C HT stainless steel, the friction coefficients for the nine GFRPI composites appeared to depend on the combined properties of both the polyimide and the fiber since different combinations produced different results (Fig. 4). However, the type A fiber produced the consistently lowest friction coefficients, 0.19 to 0.25 after run-in. The type B fiber's friction coefficients ranged from 0.20 to 0.31, and the type C's from 0.17 to 0.36.

At 300 °C, on René 41 and Haynes 6B, the friction coefficients tended to increase with sliding distance (Fig. 5), from 0.05 to 0.50. Friction was more stable for 60/40 and 80/20 PMDA/BTDA, than for 100 PMDA, and lowest for these composites with type A fibers. The disk material did not affect the friction coefficient in a regular pattern for 80/20 or 60/40 PMDA/BTDA. But for 100 PMDA much higher friction coefficients were obtained with Haynes 6B than with

René 41. The reason for this and for the variation in friction with sliding distance appears to be the type of transfer film produced, as discussed later.

The friction transition for these polyimides (with no solid lubricant added) in moist air (10 000 ppm H₂O) occurs between 100 and 160 °C (25). To determine how graphite fiber additions would affect these transitions, GFRPI pins were slid against René 41 disks as the disk temperature was raised from 25 °C to 300 °C at the rate of 4 deg C/min. A load of 9.8 N was applied and the disk was rotated at a relatively low speed of 100 rpm (0.31 m/s) to minimize frictional heating. At temperatures below the transition (~160 °C) the addition of graphite fibers reduced the friction coefficients from that for polyimide without fibers in all cases; but above the transition in some cases there was a slight reduction and in some cases equivalent friction was obtained (Fig. 6). In general, the temperature at which the transition occurred was not markedly affected by the addition of graphite fibers, but the magnitude of the friction coefficient change was reduced considerably.

Composite Wear Surface Morphology

The composite wear surfaces at 25 °C were smooth and, to varying degrees, covered with plastically flowing backtransfer composite wear particles and layers. Photomicrographs of representative wear surfaces for the three polyimides and the three types of fiber (Fig. 7) illustrate that the fibers, although randomly oriented, tend to cluster. Also shown is the good bond between the polyimide and the fiber and that the two constituents do not mix to form a surface layer except for localized backtransfer material. The fibers differ in shape and size: types A and C fibers are circular but type B fibers are bilobal. Higher magnification did not reveal any differences in fiber wear surface morphology at 25 °C, either between the different fibers or between fibers slid parallel, perpendicular, or oblique to their lengths.

The wear surfaces of the 100 and 80/20 polyimides with type A or B fibers look very similar at 300 °C (Fig. 8(a)). The wear surfaces are very smooth with no sign of thermal degradation to the fibers or the polyimides. The wear surfaces of the 100 and 80/20 polyimides with type C fibers at 300 °C showed a fine, powdery material that did not flow plastically (Fig. 8(b)). Since this did not occur with composites made from type A or B fibers, it was presumed that the fibers were either oxidizing or were in some way not thermally stable under these sliding conditions.

After 3 km of sliding at 300 °C, 60/40 PMDA/BTDA showed some surface softening of the polyimide, and the polyimide had flowed over the surface and covered the fibers (Fig. 9). Even though wear rates and friction coefficients were relatively low with this polyimide at 300 °C, it would probably not be a good candidate for applications at 300 °C because of this softening effect.

Transfer Film Morphology

GFRPI composite pin transfer to the metallic disks was studied by stopping the tests at selected intervals of sliding and observing the transfer with a light microscope at magnifications to 1600. At 25 °C the transfer tended to build up with sliding distance from thin, platelet-like transfer to a thin, continuous layer. Minor differences in transfer between the various composites did occur, but the study was not detailed enough to correlate these differences with changes in the friction coefficient and wear rate. We believe that, in general, very thin transfer and minimal backtransfer produced the lowest friction coefficients and wear rates.

For the 80/20 and 60/40 PMDA/BTDA composites at 300 °C the transfer built up to a slightly thicker film than at 25 °C, but it was still impossible to correlate differences in transfer with changes in friction and wear rate. This correlation could be made though at 300 °C for the 100 PMDA composites that had slid on René 41 or Haynes 6B. The friction coefficient obtained on René 41 was

0.28; that on Haynes 6B was 0.50. After 4 km of sliding, René 41 produced thin, flowing transfer films and Haynes 6B produced thick, nonflowing transfer films (Fig. 10). Thus, as found in previous studies (17,24,25), thin, flowing transfer is associated with low friction and wear and thick, nonflowing transfer with higher friction and wear.

Comparison with Other Polymers and Composites

Other commercially available polymer materials and composites have been evaluated under the same conditions by the authors. The composites of this study gave wear rates up to two orders of magnitude lower than any of those commercially available materials at 25 °C (Table 6). The wear rates were also about an order of magnitude lower than those of the composites formulated in the first phase of this study (24), when 100 percent BTDA polyimide was used with type B graphite fibers.

At 300 °C the composites of this study were also about an order of magnitude better than the 100 percent BTDA composites, but it is interesting to note that the 80/20 PMDA/BTDA polyimide without any fibers gave an equivalent wear rate and friction coefficient.

SUMMARY OF RESULTS

Friction, wear, and surface morphology studies of nine GFRPI composites formulated from three new polyimides and three graphite fibers had the following results:

1. Polyimides or copolyimides formulated with the diamine 4-BDAF and the dianhydride PMDA provided a more wear-resistant matrix material than polyimides formulated in a previous study (24) with the 4-BDAF diamine and the dianhydride BTDA.

2. The 80/20 PMDA/BTDA polyimide had the best combination of thermal stability and tribological properties.

3. The 60/40 PMDA/BTDA polyimide produced good tribological results at 25 °C but tended to soften at 300 °C.

4. The fiber type did not markedly affect the tribological properties of the composites, but the type C fibers tended to dust at 300 °C, a sign of possible oxidation.

5. René 41 or Haynes 6B disks wore the composites less at 300 °C than 440C HT stainless steel disks.

6. Graphite-fiber-reinforced composites produced friction transitions as did the solid polyimides (with no solid lubricant additions), but the magnitude of the friction coefficient change was not as great as for the solid polyimides.

ACKNOWLEDGMENT

The authors thank Robert J. Jones and Howard E. Green of TRW for developing and supplying the polyimides and for their helpful consultations. We also thank Edward A. Willis and Phillip R. Meng of NASA Lewis for helping to initiate the project.

REFERENCES

1. Giltrow, J.P. and Lancaster, J.K., "Properties of Carbon-Fibre-Reinforced Polymers Relevant to Applications in Tribology," International Conference on Carbon Fibres, Their Composites and Applications, Plastics Institute, London (1971) Paper 31.
2. Giltrow, J.P. and Lancaster, J.K. "Friction and Wear of Polymers Reinforced with Carbon Fibers," Nature, 214, 1106-1107 (1967).
3. Lancaster, J.K., "The Effect of Carbon Fibre Reinforcement on the Friction and Wear of Polymers," J. Phys. D., 1, 549-559 (1968).
4. Giltrow, J.P., "A Design Philosophy for Carbon Fibre Reinforced Sliding Components," Tribology, 4 (1), 21-28 (1971).

5. Harris, C.L. and Wyn-Roberts, D., "Wear of Carbon Fibre Reinforced Polymers in a High Vacuum Environment," Nature, 217, 981-982 (1968).
6. Giltrow, J.P. and Lancaster, J.K., "Carbon-Fibre Reinforced Polymers as Self-Lubricating Materials," Tribology Convention 1968, Institution of Mechanical Engineers (1968), pp. 147-157.
7. Giltrow, J.P. and Lancaster, J.K., "The Role of the Counterface in the Friction and Wear of Carbon Fibre Reinforced Thermosetting Resins," Wear, 16 (11), 359-374 (1970).
8. Simon, R.A. and Prosen, S.P., "Graphite Fiber Composites - Shear Strength and Other Properties," SPI, Proceedings of Twenty-Third Annual Technical Conference, Society of the Plastics Industry, Inc., Section 16-B (1968), pp. 1-10.
9. Herrick, J.W., "Bearing Materials from Graphite Fiber Composites," Reinforced Plastics - Ever New, Society of the Plastics Industry (1973), pp. 17-D-1 to 17-D-6.
10. Giltrow, J.P., "The Influence of Temperature on the Wear of Carbon Fiber Reinforced Resins," ASLE Trans., 16 (2), 83-90 (1973).
11. Sliney, H.E. and Johnson, R.L., "Graphite-Fiber-Polyimide Composites for Spherical Bearings to 340° C (650° F)," NASA TN D-7078 (1972).
12. Sliney, H.E., Jacobson, T.P., and Munson, H.E., "Dynamic Load Capacities of Graphite-Fiber - Polyimide Composites in Oscillating Plain Bearings to 340° C (650° F)," NASA TN D-7880 (1975).
13. Sliney, H.E. and Jacobson, T.P., "Performance of Graphite-Fiber-Reinforced Polyimide Composites in Self-Aligning Plain Bearings to 315° C," Lubr. Eng., 31 (12), 609-613 (1975).
14. Sliney, H.E. and Jacobson, T.P., "Some Effects of Composition on Friction and Wear of Graphite-Fiber-Reinforced Polyimide Liners in Plain Spherical Bearings," NASA TP-1229 (1978).

15. Fusaro, R.L. and Sliney, H.E., "Friction and Wear Behavior of Graphite Fiber Reinforced Composites," ASLE Trans., 21 (4), 337-343 (1978).
16. Lancaster, J.K., "Geometrical Effects on the Wear of Polymers and Carbons," J. Lubr. Technol., 97 (2), 187-194 (1975).
17. Fusaro, R.L., "Geometrical Aspects of the Tribological Properties of Graphite Fiber Reinforced Polyimide Composites," NASA TM-82757 (1982).
18. Gardos, M.N., and McConnell, B.D., Development of a High-Load, High-Temperature, Self-Lubricating Composite, (ASLE SP-9, Parts 1-4) ASLE (1982).
19. Brown, R.D. and Blackstone, W.R., "Evaluation of Graphite Fiber Reinforced Plastic Composites for Use in Unlubricated Sliding Bearings," Composite Materials: Testing and Design, ASTM STP-546, American Society for Testing and Materials (1974) pp. 457-476.
20. Sekiguchi, I., Yamaguchi, Y., Katsu, Y., Kamoshida, H., and Suzuki, T., "Study on Plastic Composites for Brake Shoes - On the Melamine Resin, Silicone Resin, Polyimide and Polyphenylene Oxide," Journal of JSLE, International Edition, no. 4, 17-22 (1983).
21. Vaughan, R.W., Jones, R.J., O'Rell, M.K., and Zakrzewski, G.A., "Development of Autoclave Moldable Addition-Type Polyimides," TRW Systems Group, TRW-26446-6015-RU-00, NASA CR-134900 (1976).
22. Jones, R.J., O'Rell, M.K., and Hom, J.M., "Polyimides Prepared from Perfluoroisopropylidene Diamine," U.S. Patent 4,111,906 (Sept. 5, 1978).
23. Jones, R.J., O'Rell, M.K., and Hom, J.M., "Fluorinated Aromatic Diamine," U.S. Patent 4,203,922 (May 20, 1980).
24. Fusaro, R.L., "Polyimides Formulated from a Partially Fluorinated Diamine for Aerospace Tribological Applications," NASA TM-83339 (1983).
25. Fusaro, R.L. and Hady, W.F., "Low Wear Partially Fluorinated Polyimides," ASLE Paper No. 84-LC-4A-1 (1984).

TABLE 1. - TYPICAL PROPERTIES OF GRAPHITE FIBERS

Property	Fiber type		
	A	B	C
Precursor	Polyacrylonitrile	Polyacrylonitrile	Pitch
Specific gravity	1.81	1.95	2.02
Tensile strength, GPa (psi)	2.4 (3.5x10 ⁵)	1.9 (2.8x10 ⁵)	1.4 (2.0x10 ⁵)
Tensile modulus, GPa (psi)	390 (5.7x10 ⁷)	520 (7.5x10 ⁷)	340 (4.9x10 ⁷)
Fiber elongation at break, percent	0.6	0.4	0.4
Fiber length, m	0.006	0.006	0.006
Fiber shape	Circular	Bilobal	Circular
Fiber diameter, μm	6.5	5;13	11

TABLE 2. - RUN-IN WEAR RATE AT 25 °C AFTER 33 m OF SLIDING

Fiber type	Resin composition, % PMDA/% BTDA			Average of three resins
	100/0	80/20	60/40	
Wear rate, m ³ /m of sliding				
A	10x10 ⁻¹⁵	6x10 ⁻¹⁵	13x10 ⁻¹⁵	10x10 ⁻¹⁵
B	16	8	9	11
C	8	5	10	8
Average of three fibers	11x10 ⁻¹⁵	6x10 ⁻¹⁵	10x10 ⁻¹⁵	-----

TABLE 3. - CONTACT PRESSURE AFTER 33 m OF SLIDING

Fiber type	Resin composition, % PMDA/% BTDA						Average of three resins	
	100/0		80/20		60/40			
	Contact pressure							
	MPa	psi	MPa	psi	MPa	psi	Mpa	psi
A	61	8 900	91	13 200	64	9 300	72	10 500
B	57	8 200	78	11 300	74	10 800	70	10 100
C	78	11 300	86	12 500	70	10 200	61	11 800
Average of three fibers	66	9 500	85	12 300	70	10 100	--	-----

TABLE 4. - AVERAGE WEAR RATE AT 25 °C

Fiber type	Resin composition, % PMDA/% BTDA			Average of three resins
	100/0	80/20	60/40	
	Wear rate, m ³ /m of sliding			
A	12x10 ⁻¹⁷	11x10 ⁻¹⁷	28x10 ⁻¹⁷	17x10 ⁻¹⁷
B	44	11	4	20
C	11	30	10	17
Average of three fiber.	22x10 ⁻¹⁷	17x10 ⁻¹⁷	14x10 ⁻¹⁷	-----
No fibers	300	7	7	-----

TABLE 5. - AVERAGE WEAR RATE AT 300 °C

Fiber type	Disk	Test	Resin composition, PMDA/ BTDA			Average of three resins
			100/0	80/20	60/40	
			Wear rate, m ³ /m of sliding			
A	René 41	1	68x10 ⁻¹⁵	65x10 ⁻¹⁵	73x10 ⁻¹⁵	}69x10 ⁻¹⁵
		2	79	58	65	
		3	49	73	77	
	Haynes 6B	1	62	75	65	}66
		2	67	49	57	
		3	58	90	74	
B	René 41	1	39	36	38	}41
		2	48	51	31	
		3	41	42	39	
	Haynes 6B	1	47	34	36	}39
		2	55	29	26	
		3	42	40	42	
C	René 41	1	37	28	36	}37
		2	56	42	29	
		3	34	34	41	
	Haynes 6B	1	44	27	41	}37
		2	49	21	54	
		3	27	36	30	
Average of three fibers	Average of two disks	-	50	47	47	-----
No fibers ^a	René 41	-	100	35	120	-----

^aData from Ref. 25.

TABLE 6. - AVERAGE FRICTION COEFFICIENTS AND WEAR RATES FOR COMMERCIAL AND EXPERIMENTAL POLYMERS

[Load, 9.8 N; sliding speed, 1000 rpm (2.7 to 3.1 m/s); relative humidity, 50 percent.]

Pin material	Disk material	Temperature, °C			
		25	300	25	300
		Average friction coefficient		Average wear rate, m ³ /m of sliding	
Commercial polymers					
440C HT stainless steel ^b	Polyphenylene sulfide with 40 percent graphite fibers	0.30	----	620x10 ⁻¹⁵	-----
440C HT stainless steel ^b	Poly(amide-imide) PTFE with graphite powders	.37	----	180	-----
Polyimide ^b	René 41	.48	0.30	48	75x10 ⁻¹⁵
Ultrahigh-molecular-weight polyethylene ^b	440C HT stainless steel	.30	----	6	-----
Polyimide with graphite powder ^b	440C HT stainless steel	.64	----	5	-----
Experimental polymers					
PMDA ^b	Haynes 6B	0.60	0.23	27x10 ⁻¹⁵	100x10 ⁻¹⁵
Graphite-fiber-reinforced, addition type of polyimide ^a	440C HT stainless steel	.30	.55	12	190
80/20 PMDA/BTDA ^b	Haynes 6B	.90	.20	5	35
60/40 PMDA/BTDA ^b	Haynes 6B	.80	.22	5	120
Graphite-fiber-reinforced BTDA ^a	440C HT stainless steel	.30	.35	2	420

^aData from Ref. 24.^bData from Ref. 25.

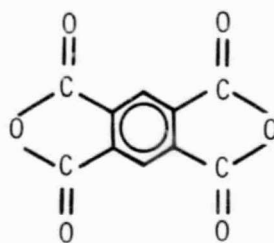
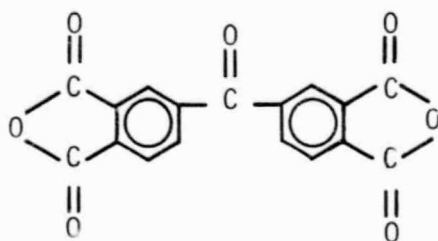
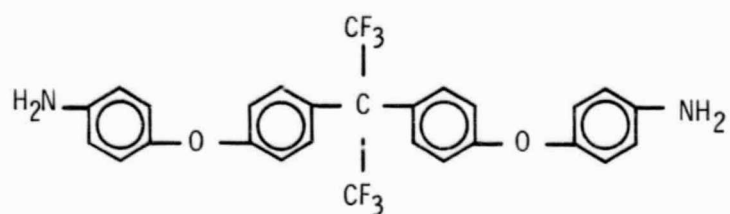

- (a) Diamine (4-BDAF).
 (b) Dianhydride (BTDA).
 (c) Dianhydride (PMDA).

Figure 1. - Monomers used to formulate new polyimides.

ORIGINAL PAGE IS
OF POOR QUALITY

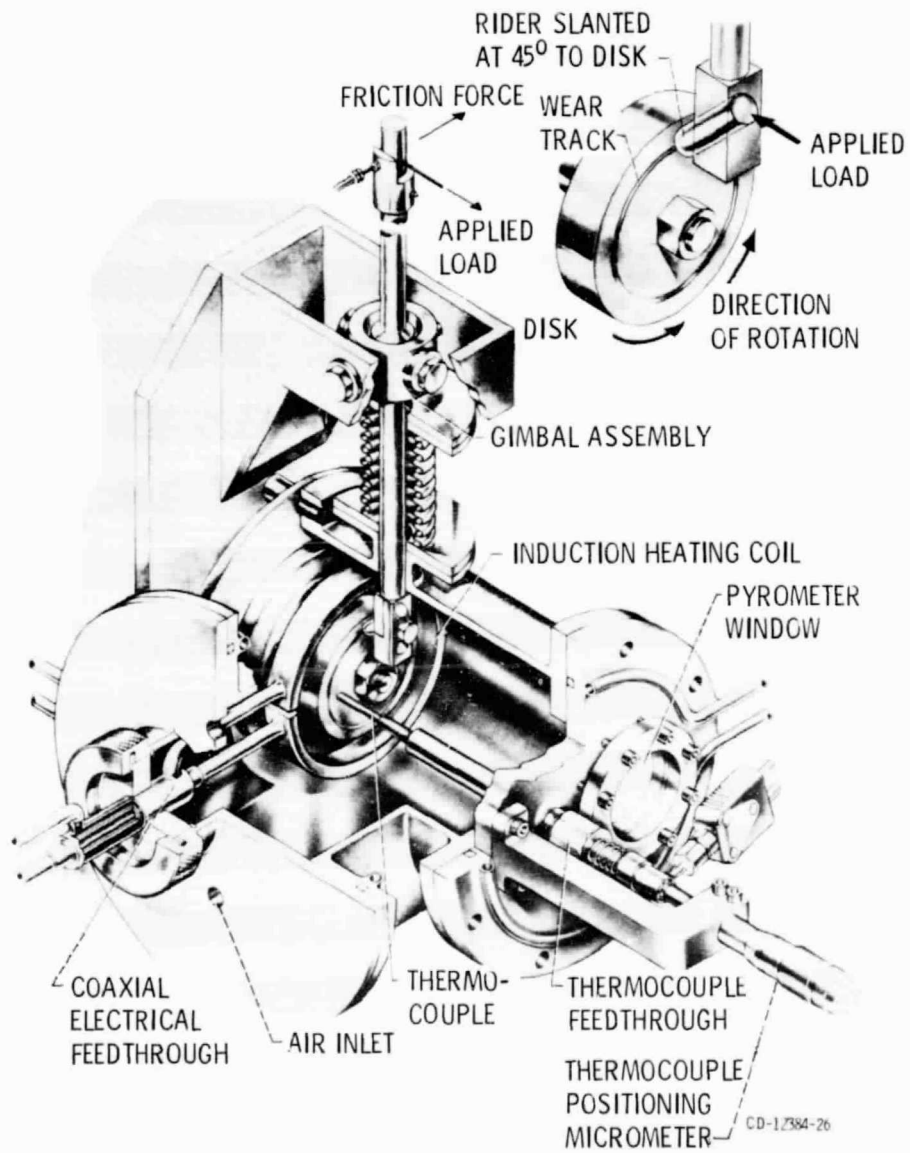
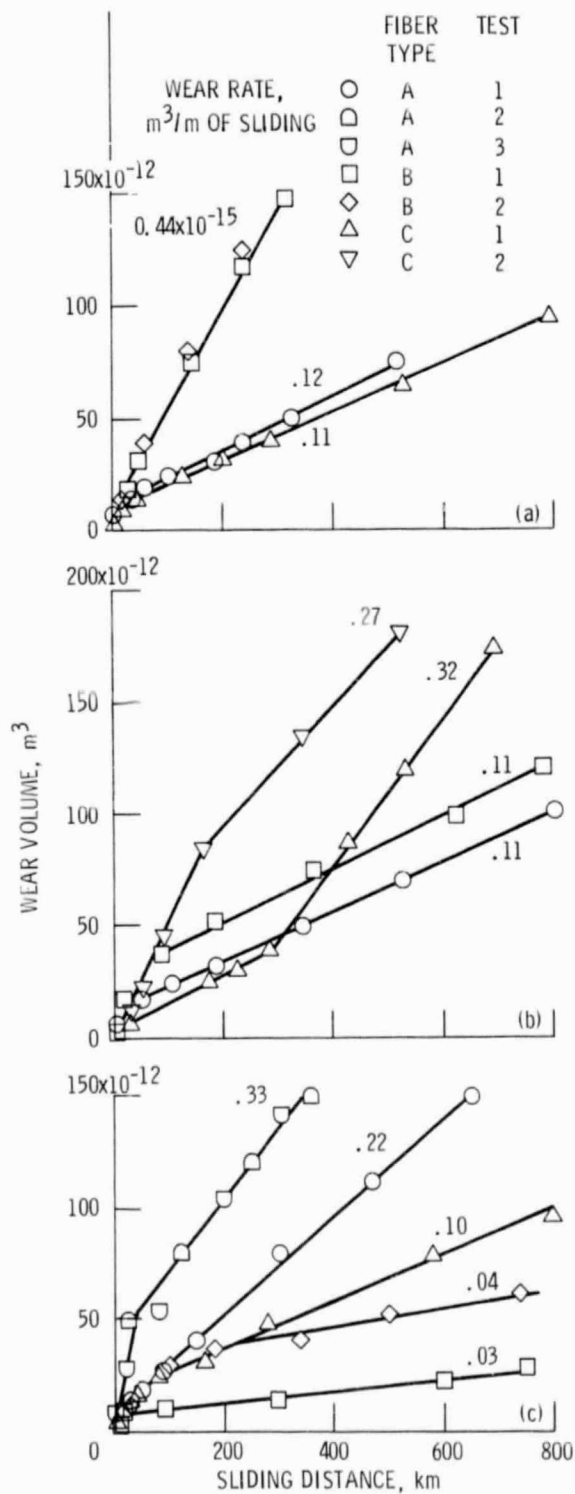
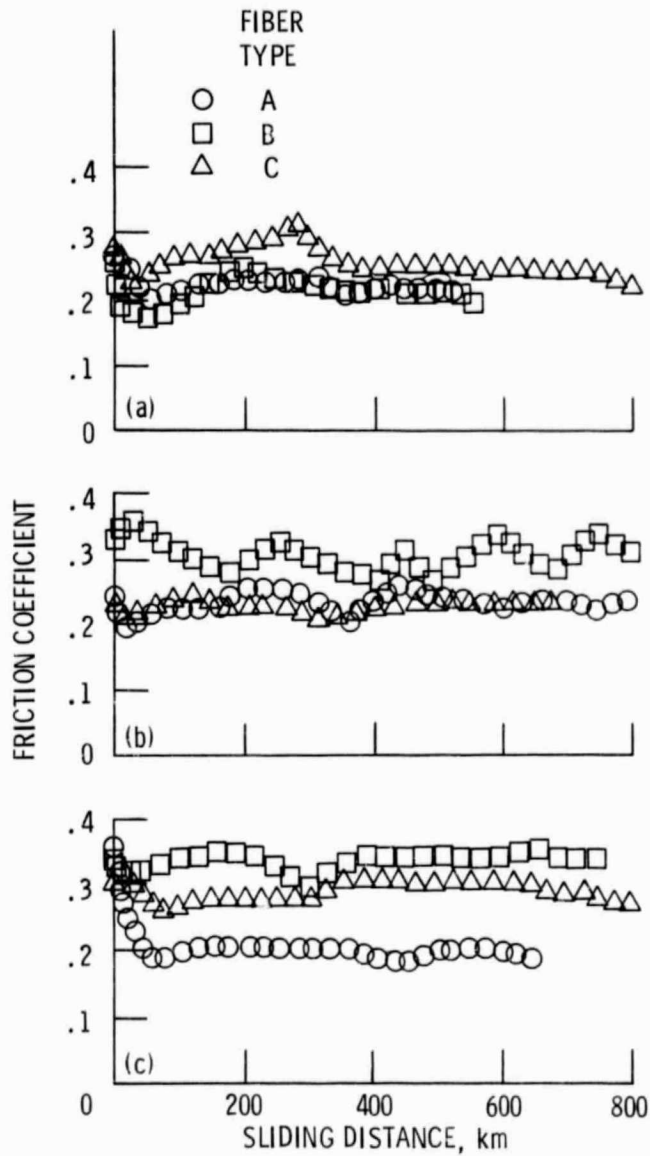

Figure 2. - Pin-on-disk tribometer.



- (a) 100 PMDA polyimide.
- (b) 80/20 PMDA/BTDA polyimide.
- (c) 60/40 PMDA/BTDA polyimide.

Figure 3. - Wear of graphite-fiber-reinforced polyimide composite pins as a function of sliding distance at 25 °C.



- (a) 100 PMDA polyimide.
 (b) 80/20 PMDA/BTDA polyimide.
 (c) 60/40 PMDA/BTDA polyimide.

Figure 4. - Typical plots of friction coefficient as a function of sliding distance for GFR/PI pins sliding against 440C HT stainless steel disks at 25 °C.

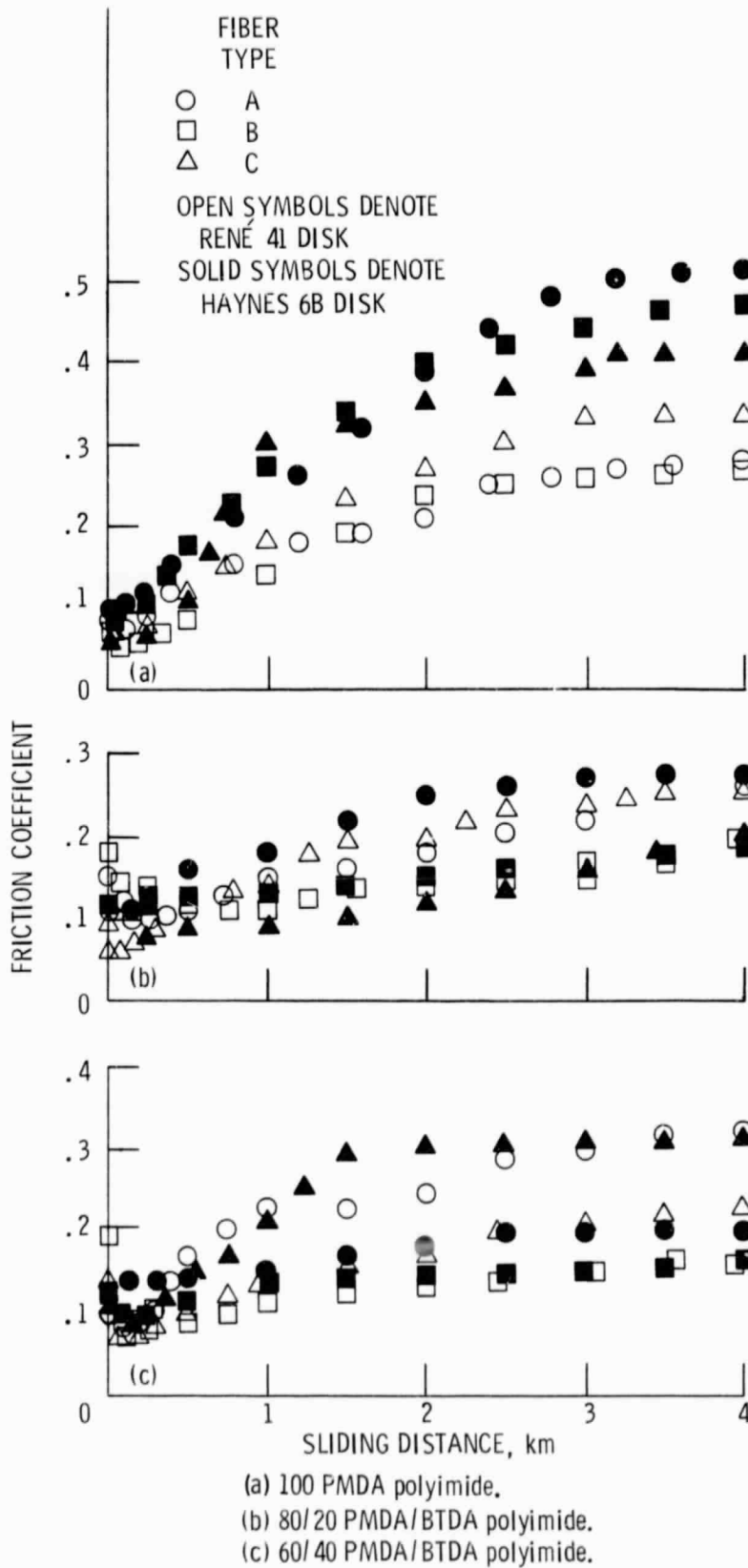
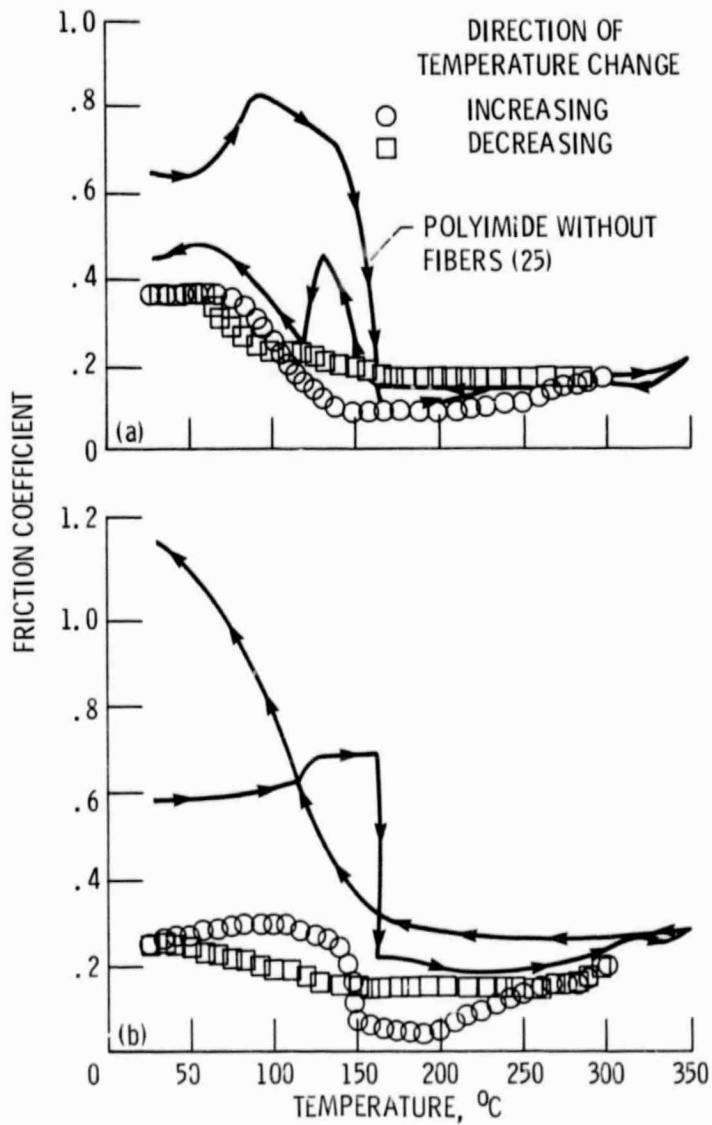

Figure 5. - Typical plots of friction coefficient as a function of sliding distance for GFRPI pins sliding against René 41 or Haynes 6B disks at 300 °C.



(a) 100 PMDA polyimide - type B fibers.

(b) 80/20 PMDA/BTDA polyimide - type A fibers.

Figure 6. - Friction coefficient as a function of temperature for representative GFRPI composites.

ORIGINAL PAGE IS
OF POOR QUALITY

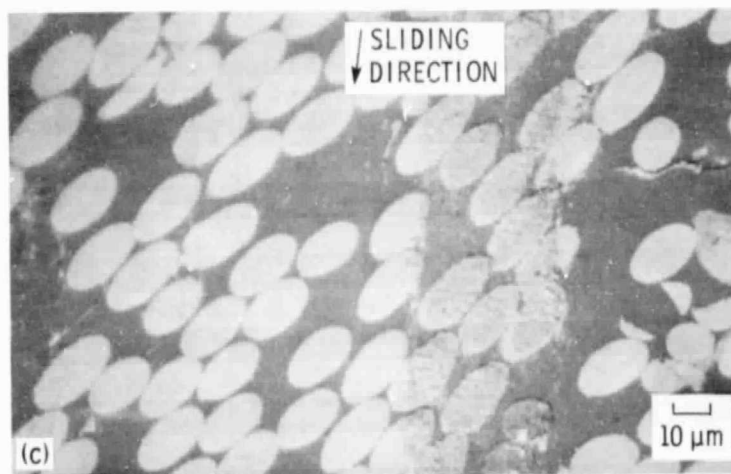
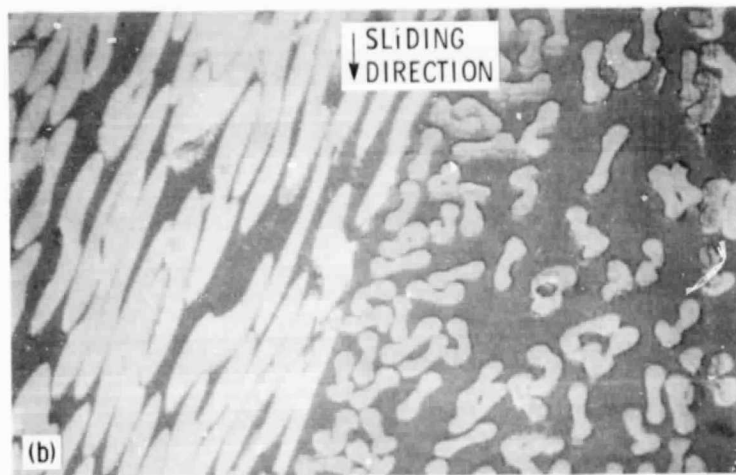
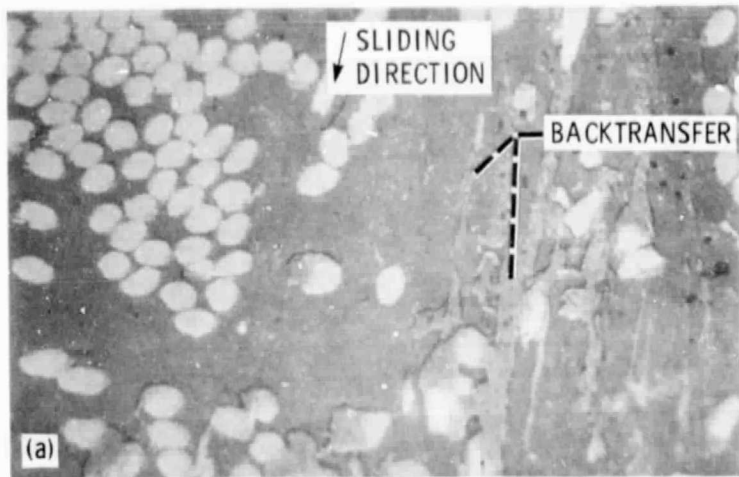

(a) 100 PMDA polyimide - type A fibers.

(b) 60/40 PMDA/BTDA polyimide - type B fibers.

(c) 80/20 PMDA/BTDA polyimide - type C fibers.

Figure 7. - Photomicrographs of GFRPI pin wear surfaces
after sliding against 440C HT stainless steel at 25 °C.

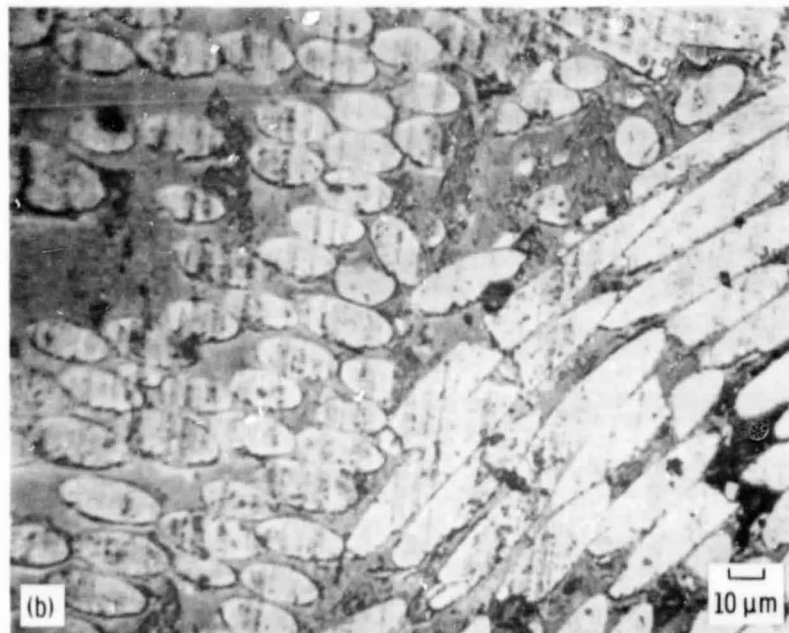

(a) Type B fibers.

(b) Type C fibers.

Figure 8. - Photomicrographs of wear surfaces of 80/20 PMDA/BTDA polyimide reinforced with type B and type C fibers, after 3 km of sliding at 300 °C.

ORIGINAL PAGE IS
OF POOR QUALITY



Figure 9. - Photomicrograph of wear surface of 60/40 PMDA/BTDA polyimide reinforced with type B fibers, after 3 km of sliding at 300 °C.

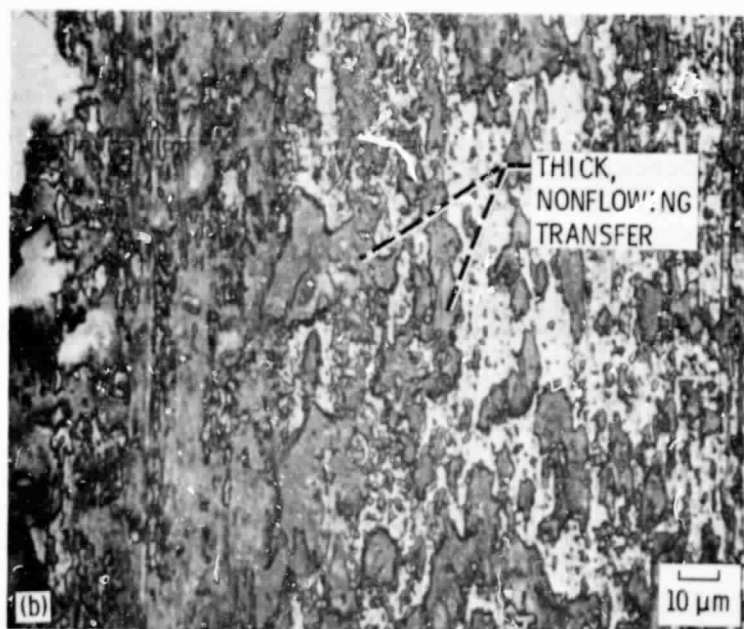
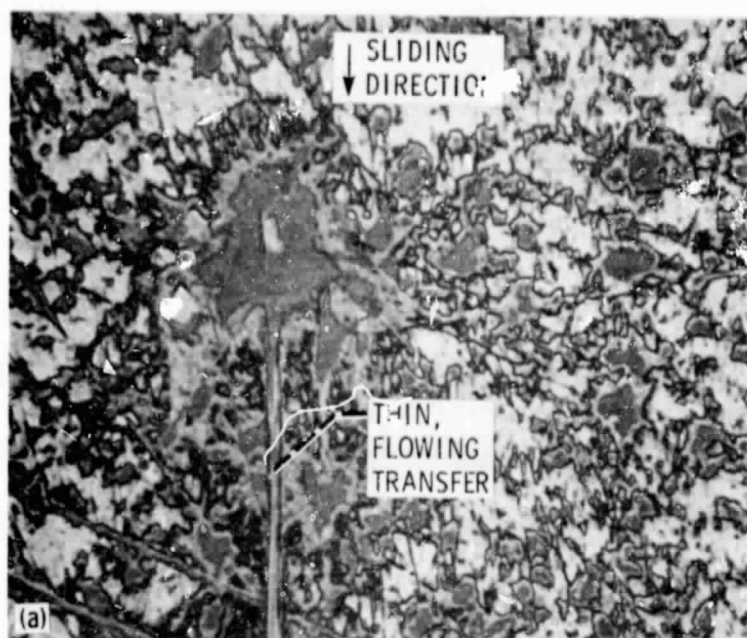

(a) René 41 disk.
(b) Haynes 6B disk.

Figure 10. - Photomicrographs of transfer at 300 °C to René 41 and Haynes 6B disks from composite pins of 100 PMDA reinforced with type A fibers.