

General Disclaimer

One or more of the Following Statements may affect this Document

- This document has been reproduced from the best copy furnished by the organizational source. It is being released in the interest of making available as much information as possible.
- This document may contain data, which exceeds the sheet parameters. It was furnished in this condition by the organizational source and is the best copy available.
- This document may contain tone-on-tone or color graphs, charts and/or pictures, which have been reproduced in black and white.
- This document is paginated as submitted by the original source.
- Portions of this document are not fully legible due to the historical nature of some of the material. However, it is the best reproduction available from the original submission.

(NASA-CR-174376) LYMAN ALPHA CORONAGRAPH
RESEARCH SOUNDING ROCKET PROGRAM Final
Report, 15 Jul. 1976 - 28 Feb. 1985 (Harvard
Coll. Observatory) 38 p HC A05/MF A01

N85-18517

CSSL 04A G3/46

Unclas
14164

LYMAN ALPHA CORONAGRAPH RESEARCH
SOUNDING ROCKET PROGRAM

NASA Grant No. NSG-5128

Dr. W.H. Parkinson, Principal Investigator

Dr. John L. Kohl, Principal Scientist

FINAL REPORT

For the period 15 July 1976 through 28 February 1985

Prepared for

National Aeronautics and Space Administration
Headquarters
Washington, D.C. 20546

by

Harvard College Observatory
60 Garden Street
Cambridge, Massachusetts 02138

The Harvard College Observatory
is a member of the
Harvard-Smithsonian Center for Astrophysics



Final Report

NASA Grant NSG-5128

LYMAN ALPHA CORONAGRAPH RESEARCH - SOUNDING ROCKET PROGRAM

ABSTRACT

Under this grant, the Ultraviolet Light Coronagraph was developed and successfully flown on three rocket flights on 13 April 1979, 16 February 1980 and 20 July 1982. During each of these flights, the Ultraviolet Light Coronagraph was flown jointly with the White Light Coronagraph provided by the High Altitude Observatory.

The primary objectives of this program were to develop and verify new UV diagnostic techniques and instrumentation for determining the basic plasma parameters of solar wind acceleration regions in the extended corona and to advance the understanding of the physics of the corona through the performance, analysis and interpretation of solar observations. The program was highly successful and demonstrated that valuable UV diagnostics can be performed in the absence of a natural solar eclipse.

1.0 INTRODUCTION

Under this grant, the Ultraviolet Light Coronagraph (UVC) was developed and successfully flown on three rocket flights. During each of these flights, the Ultraviolet Light Coronagraph was flown jointly with the White Light Coronagraph (WLC) provided by the High Altitude Observatory.

The primary objectives of this program were to develop and verify new UV diagnostic techniques and instrumentation for determining empirical models of

the extended solar corona and to advance the understanding of the physics of the corona through the analysis and interpretation of spectroscopic observations.

The UVC, which was initially called the Lyman Alpha Coronagraph, was originally built to carry out the first direct measurements of the spectral line profile and intensity of hydrogen Lyman- α radiation at selected spatial elements in the solar corona. These measurements, when combined with measurements of the polarization and brightness of the visible corona, allowed for determinations of temperatures and densities in a coronal streamer, in quiet coronal regions, and in three coronal holes at heights from 1.5 to 3.5 solar radii from sun center. Such information is critical to the development of a theoretical understanding of coronal heating and solar wind acceleration.

The UVC was flown successfully on 13 April 1979 and proton temperatures in the solar wind acceleration region of the solar corona were measured directly for the first time. The three regions observed during this first flight were a coronal hole at 1.5 - 2.0 R_{\odot} , a quiet coronal region at 1.5 - 3.5 R_{\odot} and a coronal streamer at 1.5 R_{\odot} .

Following the April flight, a post-flight radiometric calibration was performed, the instrument was refurbished, several modifications were implemented, and the UVC was prepared for a flight at the time of the 16 February 1980 eclipse. Having proved that such UV diagnostics could be performed in the absence of a natural eclipse, the objective of the second flight was to obtain UV data to be coordinated with ground-based and satellite data in support of a comprehensive study of the corona at solar maximum.

The second joint flight of the UVC and the visible light coronagraph was accomplished successfully on 16 February 1980, just seven hours after the

natural solar eclipse over Africa, India and China. The UVC performed flawlessly and obtained 57 high quality scans of the Lyman- α line for seven lines-of-sight in two separate coronal regions. The measurements were obtained for a coronal hole near the south heliocentric pole at radial distances of 1.5 - 3.5 R_{\odot} from sun center and for a quiet coronal region at 1.5 - 2.8 R_{\odot} . These observations provided the only UV data to complement ground-based observations of the 1980 solar eclipse.

Subsequent to the 1980 flight, the UVC was refurbished and substantial modifications were made to the instrument to allow for simultaneous coronagraphic observations of H I $\lambda 1216$, O VI $\lambda 1032$ and $\lambda 1037$ radiation. These modifications permitted the first application of a new diagnostic for coronal outflow velocities in the 25 - 100 km s^{-1} range which is necessary because the coronal Lyman- α measurements are not sensitive to such low velocities.

The third successful joint rocket flight of the UVC and the White Light Coronagraph took place on 20 July 1982. During this flight, the UVC observed a polar coronal hole and a coronal streamer. Measurements at 1.5 R_{\odot} and 2.0 R_{\odot} of the H I Lyman- α line profile and the intensity of O VI $\lambda 1032$ and $\lambda 1037$ were made for each of the observed coronal structures.

The three rocket flights of the UVC have proven the feasibility of making coronagraphic observations of the solar UV corona out to 3.5 R_{\odot} and beyond. Each rocket flight provided observations of the resonantly scattered H I Lyman- α profile at two to three locations in a coronal hole and three to five locations in a quiet coronal region. The spatial resolution elements were 0.6 arc minutes x 4 arc minutes. These measurements have yielded exciting new information about the coronal plasma. The Lyman- α profiles have provided direct measurements of proton kinetic temperatures and evidence for either

non-thermal plasma motions, probably caused by waves, or a small amount of proton heating between the coronal base and $4 R_{\odot}$. Comparison of the Lyman- α intensities and the visible light observations of the High Altitude Observatory have indicated that the outflow velocity of protons at $4 R_{\odot}$ is subsonic in the coronal hole observed on 16 February 1980. This result is in sharp contrast to the supersonic velocities inferred from the Munro and Jackson (1977) analysis of a broader coronal hole observed in 1973. Our results suggest that the primary solar wind acceleration may occur above $4 R_{\odot}$ --an hypothesis that is consistent with an Alfvén wave driven wind (see, for example, Hollweg, 1981). The data also indicate that the proton temperature varies from region to region in the corona.

The following scientific papers were published, prepared for publication or presented at scientific meetings:

- "The Lyman Alpha Coronagraph," J.L. Kohl, E.M. Reeves, and B. Kirkham, in New Instrumentation for Space Astronomy, eds. K. van der Hucht and G.S. Vaiana (Oxford and New York: Pergamon Press, 1978), p. 91.
- "Lyman Alpha Line Profiles from 1.5 to 3.0 Solar Radii," J.L. Kohl, H. Weiser, G.L. Withbroe, R.H. Munro, W.H. Parkinson, and E.M. Reeves, presented at 154th Meeting of A.A.S., Wellesley, MA, June; B.A.A.S. 11, 398 (1979).
- "Lyman- α and White Light Observations of the Outer Solar Corona," R.H. Munro, J.L. Kohl, R.M. MacQueen, R.W. Noyes, W.H. Parkinson, H. Weiser, and G.L. Withbroe, presented at 154th Meeting of A.A.S., Wellesley, MA, June; B.A.A.S. 11, 398 (1979).
- "The Rocket Lyman Alpha Coronagraph," H. Weiser, J.L. Kohl, and B. Kirkham, B.A.A.S. 11, 397 (1979).
- "Coronal Lyman Alpha Profiles," J.L. Kohl, H. Weiser, G.L. Withbroe, R.H. Munro, W.H. Parkinson, and E.M. Reeves, presented at Meeting of the

International Astronomical Union, Montreal, August, 1979.

"Lyman Alpha and White Light Observations of the Outer Solar Corona," R.H.

Munro, J.L. Kohl, R.M. MacQueen, R.W. Noyes, W.H. Parkinson, H. Weiser, and G.L. Withbroe, presented at Meeting of the International Astronomical Union, Montreal, August, 1979.

"The Temperature Structure of the Solar Corona," G.L. Withbroe, invited paper presented in the special session of Solar Interplanetary Physics on from 2 to 20 Solar Radii: Remote Sensing and Speculation at the 1979 AGU Spring Meeting, Washington, DC; also EOS, 6Q, 367 (1979).

"Measurements of Coronal Kinetic Temperatures from 1.5 to 3 Solar Radii," J.L. Kohl, H. Weiser, G.L. Withbroe, R.W. Noyes, W.H. Parkinson, E.M. Reeves, R.M. MacQueen, and R.H. Munro, *Astrophys. J.* 241, L117 (1980).

"Ultraviolet Spectroscopy of the Solar Corona Beyond 1.5 Solar Radii," J.L. Kohl, invited paper presented at Sixth International Colloquium on UV and X-Ray Spectroscopy of Astrophysical and Laboratory Plasmas, IAU Colloquium No. 55, Toronto (1980).

"Spectroscopy of the Corona Between 1 and 8 Solar Radii," G.L. Withbroe and J.L. Kohl, invited paper presented at Meeting of A.A.S. Solar Physics Division, College Park, MD, June, 1980.

"Spectroscopy of the Corona Between 1 and 8 Solar Radii," G.L. Withbroe, colloquium presented at Sacramento Peak Observatory, August 27, 1980.

"The Spacelab Lyman-Alpha and White-Light Coronagraphs Program, J.L. Kohl, R.M. MacQueen, G.L. Withbroe, R.H. Munro, and H. Weiser, *B.A.A.S.* 12, 793 (1981).

"Implications of Lyman Alpha Measurements on Coronal Electron and Proton Temperatures Between 2.0 and 4.0 Solar Radii," G.L. Withbroe, J.L. Kohl, and H. Weiser, *B.A.A.S.* 12, 917 (1981).

"Coronagraphic H I Lyman-Alpha Observations Following the 1980 Solar Eclipse,"

H. Weiser, J.L. Kohl, W.H. Parkinson, and G.L. Withbroe, B.A.A.S. 12, 917 (1981).

"The Spacelab Lyman Alpha and White Light Coronagraphs Program," J.L. Kohl, G.L. Withbroe, H. Weiser, R.M. MacQueen, and R.H. Munro, presented at conference on Solar Physics from Space, Zurich, Switzerland; Space Sci. Rev. 29, 419 (1981).

"Activity and Outer Atmosphere of the Sun," G.L. Withbroe, invited lecture series in mini-course sponsored by Swiss Society of Astronomy and Astrophysics, presented in Saas-Fee, Switzerland, April. Published in Activity and Outer Atmospheres of the Sun and Stars, E. Praderie, D. Spicer and G.L. Withbroe (Observatoire de Geneve, Sauverny, Switzerland, 1981), pp. 1-88.

"Coronagraphic Measurements of the Solar Wind Acceleration Region," J.L. Kohl, G.L. Withbroe, H. Weiser, R.M. MacQueen, and R.H. Munro, presented at Spring Meeting of the American Geophysical Union, Baltimore, MD; EOS, Trans. AGU 62, 376 (1981).

"Coronagraphic Measurements of Proton Temperature from 1.5 to 3.5 Solar Radii," G.L. Withbroe, J.L. Kohl, H. Weiser, and R.H. Munro, presented at Spring Meeting of the American Geophysical Union, Baltimore, MD; EOS, Trans. AGU 62 376 (1981).

"Coronal Temperatures from 1.5 to 4 Solar Radii," J.L. Kohl, G.L. Withbroe, H. Weiser, and R.H. Munro, paper presented at Huntsville Solar-Terrestrial Meeting, Huntsville, AL (1981).

"1980 Coronagraphic Measurements in the Solar Wind Acceleration Region," G.L. Withbroe, J.L. Kohl, R.H. Munro, and H. Weiser, presented at Second Cambridge Workshop on Cool Stars, Stellar Systems and the Sun, October, 1981 (published in conference proceedings).

"Shuttle Contamination Effects on UV Coronagraph Observations," J.L. Kohl and

- H. Weiser, presented at Technical Symposium of S.P.I.E., Washington, DC; Proceedings of S.P.I.E. 287, 35 (1981).
- "Spectroscopic Probing of the Solar Wind Acceleration Region," G.L. Withbroe, colloquium presented at the University of New Hampshire, December, 1981.
- "Plans for Calibration of UV and EUV Experiments on Spacelab," J.L. Kohl and H. Weiser, presented at Sixth Workshop on VUV Radiometric Calibration of Space Experiments at NCAR, Boulder, CO (1981).
- "Analysis of Coronal H I Lyman Alpha Measurements from a Rocket Flight on 13 April 1979," G.L. Withbroe, J.L. Kohl, H. Weiser, G. Noci, and R.H. Munro, *Astrophys. J.* 254, 361 (1982).
- "Results of Lyman- α Coronagraphic Observations Following the 1980 Eclipse," H. Weiser, J.L. Kohl, R.H. Munro, and G.L. Withbroe, *B.A.A.S.* 13, 913 (1982).
- "Coronal Outflow Velocities: 1980 Rocket Measurements," R.H. Munro, J.L. Kohl, H. Weiser, and G.L. Withbroe, *B.A.A.S.* 13, 912 (1982).
- "EUV Spectroscopic Plasma Diagnostics for the Solar Wind Acceleration Region," J.L. Kohl and G.L. Withbroe, *Astrophys. J.* 256, 263 (1982).
- "Probing the Solar Wind Acceleration Region Using Spectroscopic Techniques," G.L. Withbroe, J.L. Kohl, H. Weiser, and R.H. Munro, invited paper presented at IXth Lindau Workshop on "The Source Region of the Solar Wind," Max Planck Institut fur Aeronomie, Lindau, West Germany, November, 1981; *Space Sci. Rev.* 33, 17 (1982).
- "New Observations of the Extended Ultraviolet Corona," J.L. Kohl, H. Weiser, G.L. Withbroe, and R.H. Munro, *B.A.A.S.* 14, 976 (1982).
- "The Ultraviolet Light Coronagraph--A New Spectroscopic Tool for Studying the Solar System," J.L. Kohl, colloquium presented at Harvard-Smithsonian Center for Astrophysics, April, 1982.
- "Future Observations of Solar Wind Origin," J.L. Kohl, invited paper presented

at Solar Wind V, Woodstock, VT, November, 1982.

"Probing the Solar Wind Acceleration Region," G.L. Withbroe, colloquium presented at Naval Research Laboratory, Washington, D.C., February, 1983.

"Spectroscopic Measurements of Solar Wind Generation," J.L. Kohl, G.L. Withbroe, C.A. Zapata, and G. Noci, in Solar Wind V, ed. M. Neugebauer, NASA (1983) p. 47.

"Observations Related to Waves in the Solar Wind Acceleration Region," G.L. Withbroe, paper presented at Solar Terrestrial Physics Workshop, Berkeley Springs, WV, June, 1983.

"Spectroscopic Constraints on Solar Wind Models," J.L. Kohl, invited lecture presented at Osservatorio Astrofisico di Arcetri, U. of Florence, July, 1983.

"Solar Wind and Coronal Structure," G.L. Withbroe, invited paper presented at National Academy of Sciences--European Science Foundation Workshop on Solar System Space Physics, S. Carolina, September; ESA Journal 7, 341 (1983).

"Evidence for Supersonic Wind Velocities at 2.1 Solar Radii," J.L. Kohl, H. Weiser, G.L. Withbroe, C.A. Zapata, and R.H. Munro, presented at A.A.S. meeting, Baltimore, MD, June; B.A.A.S. 16, 531 (1984).

"Coronal Temperatures, Heating and Energy Flow in a Polar Region of the Sun at Solar Maximum," G.L. Withbroe, J.L. Kohl, H. Weiser, and R.H. Munro, submitted to Astrophys. J.

In section 2 we discuss the observations carried out during each flight and review the scientific analyses, and in section 3 we review the development of the UVC instrument.

2.0 SCIENTIFIC ANALYSIS OF ROCKET OBSERVATIONS

2.1 13 April 1979 Flight

During the 13 April 1979 rocket flight, Lyman- α line profiles were obtained in a quiet coronal region for five lines of sight through 4 arc minute \times 0.6 arc minute spatial elements between 1.5 and 3.0 R_{\odot} from disk center and three lines of sight through an apparent coronal hole out to 2 R_{\odot} . Lyman- α profiles at 1.5 R_{\odot} in a coronal streamer were measured also. The instrument performed flawlessly and the data are of high quality.

The observed profiles seem to be free of stray light contamination or any other source of background noise. Stray light is distinguished from coronal radiation in the instrument because it has the characteristically self-reversed line profile of chromospheric Lyman alpha. Evidence of negligible stray light came from comparisons of observations at 3.5 R_{\odot} in a quiet coronal region and in a coronal hole. The quiet coronal profile is broad and characteristically weaker than quiet coronal profiles for smaller radial distances and the line profile obtained from the coronal hole is very narrow (indicative of the geocoronal profile) with only an extremely weak broad contribution due to weak coronal hole emission and/or to stray chromospheric radiation. Since the decrease in vignetting in the UVC for observations at 3.5 R_{\odot} tends to increase the stray light signal, negligible stray light at 3.5 R_{\odot} imply a negligible stray light problem at Lyman alpha for smaller radial distances.

The primary objective of the first rocket flight of the joint UVC and White Light Coronagraph was the verification of the design and performance of the UVC and the measurement of coronal Lyman- α intensities and line profiles in several different coronal structures at heliocentric distances out to 3.5 R_{\odot} .

A paper entitled "Measurements of Coronal Kinetic Temperature from 1.5 to 3 Solar Radii," Kohl *et al.* 1980, presented preliminary results of the 13 April 1979 rocket flight. Among these was the finding that the proton kinetic temperature derived from the widths of Lyman- α profiles measured in a quiet unstructured region of the corona decreased with increasing solar radius from 1.5 to 4 R_{\odot} . Results were also presented for a coronal hole where measurements at 1.8 and 2 R_{\odot} indicated a kinetic temperature of 1.6×10^6 K. Another paper entitled "Analysis of Coronal H I Lyman α Measurements from a Rocket Flight on 13 April 1979," Withbroe *et al.* 1982a, reported a detailed analysis of the measurements of the Lyman- α line profiles and intensities made in the quiet region observed in April 1979. The paper presented refined values of the proton kinetic temperatures and comparisons to coronal models. The UV measurements combined with temperatures derived by other methods for lower heights suggest that there is a maximum in the quiet coronal proton temperature at about 1.5 R_{\odot} . The empirical temperatures are in good agreement with the temperature calculated with the simple two-fluid solar wind model in which there is a small amount of direct heating of protons between 1.5 and 4 R_{\odot} . The radial gradient of the measured Lyman- α intensities is also consistent with the predictions of the two-fluid model. The observed decrease of the proton temperature with height is evidence for the presence of solar wind outflow in the observed region. Comparison of the observations and models suggest that the flow velocity at 4 R_{\odot} is less than 130 km s^{-1} . Indications of the magnitude and location of coronal proton heating provided by the measurements place constraints on possible coronal heating mechanisms. A detailed analysis of the coronal hole measurements acquired during the 1979 flight is in progress.

2.2 16 February 1980 Flight

During the 16 February 1980 flight, Lyman- α line profiles were obtained in quiet coronal region for three lines of sight between 1.5 and 2.5 R_{\odot} from disk center and four lines of sight through a coronal hole out to 3.5 R_{\odot} (see Table 1). Again the instrument performed flawlessly.

TABLE 1. Lyman- α Intensities and Widths (16 Feb. 1980 Flight)				
ρ (R_{\odot})	No. Scans	Intensity Measured*	(photon $\text{cm}^{-2} \text{s}^{-1} \text{sr}^{-1}$) Corrected for Geocorona	Width (1/e half width, \AA)
Quiet Region				
1.5	2	4.0(11)	4.4(11)	0.59
1.8	6	9.9(11)	1.1(11)	0.58
2.8	14	8.7(11)	7.9(9)	0.53
Coronal Hole				
1.5	14	1.7(11)	1.7(11)	0.54
2.5	9	8.5(9)	8.0(9)	0.43
3.0	2	4.3(9)	3.6(9)	0.42
3.5	2	2.9(9)	2.1(9)	0.41

*Number in parenthesis is power of 10.

The primary objective of the 1980 flight was to study a coronal hole located at the southern solar pole. Coronal holes are thought to be a major source of solar wind, particularly high speed solar wind streams. Consequently, coronagraphic determinations of plasma parameters of these features are of considerable importance.

Results of the Lyman-alpha and white light observations acquired during the 16 February 1980 flight of the UVC and White Light Rocket Coronagraph have been reported in several publications and in a number of presentations at national and international scientific meetings (c.f. "Probing the Solar Wind Acceleration Region Using Spectroscopic Techniques," Withbroe et al. 1982b;

"Implications of Lyman Alpha Measurements on Coronal Electron and Proton Temperatures Between 2.0 and 4.0 Solar Radii," Withbroe *et al.* 1981; "Coronagraphic Measurements of the Solar Wind Acceleration Region," Kohl *et al.* 1981; and "Coronal Temperatures, Heating and Energy Flow in a Polar Region of the Sun at Solar Maximum," Withbroe *et al.* 1985.

An example of the quality of the spectroscopic data that can be obtained with an Ultraviolet Light Coronagraphic Instrument is shown in Figure 2-1 which presents a profile (solid line) of the resonantly scattered component of hydrogen Lyman- α measured at $\rho = 1.8 R_{\odot}$ in the polar region observed in the 1980 rocket flight. The parameter ρ is the distance measured in solar radii from sun-center to the point where the line of sight intersects the plane of the disk. The measured profile has been fitted with a profile calculated for an isothermal corona. This illustrates how well this particular observation is represented by a Maxwellian velocity distribution function for the hydrogen atoms along the line of sight. A recently completed detailed analysis of other profiles measured during the 1980 flight indicates that excellent fits can be made to all of the profile measurements from this flight.

Measurements of spectral line profiles provide information on kinetic temperatures in the region where the spectral line radiation originated. By measuring profiles at several heights in the corona one can obtain information on the temperature gradient in the observed region. Figure 2-2 shows hydrogen kinetic temperatures determined from Lyman- α profiles measured at several positions ρ on a radius vector directed along the axis of the coronal hole that was centered on the south pole during February 1980. Measured temperatures are plotted at the radii ($r = 1.6, 2.8, 3.4$ and $4 R_{\odot}$) corresponding to the mean heights where the radiation observed at $\rho = 1.5, 2.5, 3.0$ and $3.5 R_{\odot}$ originated (see Withbroe *et al.* 1985). The heavy solid line is the inferred

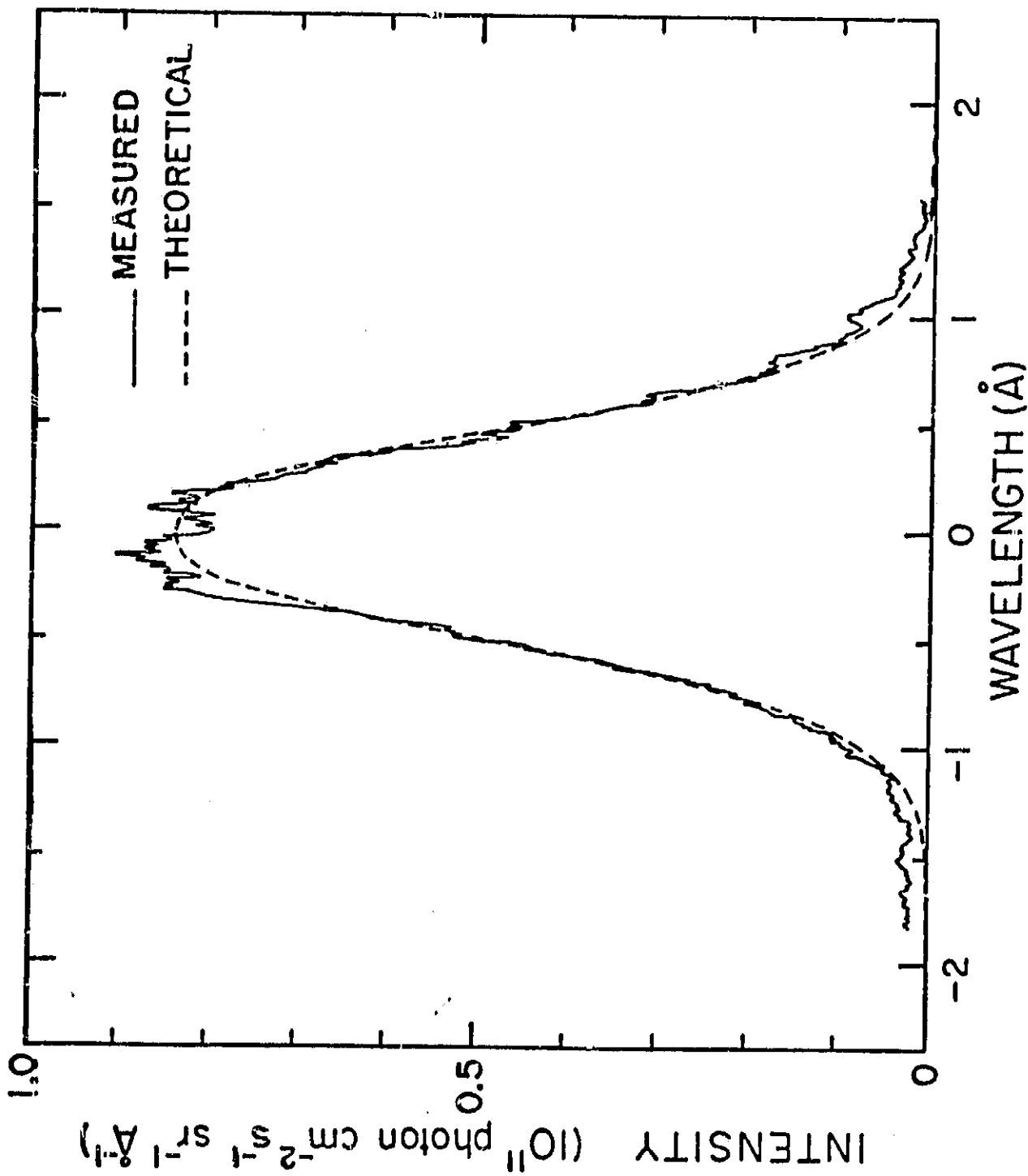

Figure 2-1. A comparison of a measured (solid line) and theoretical (dashed line) profiles of the resonantly scattered component of Lyman- α . The measured profile was taken in a polar region near the edge of a coronal hole. The theoretical profile has been convolved with the instrumental profile which has a FWHM = 0.35 Å.

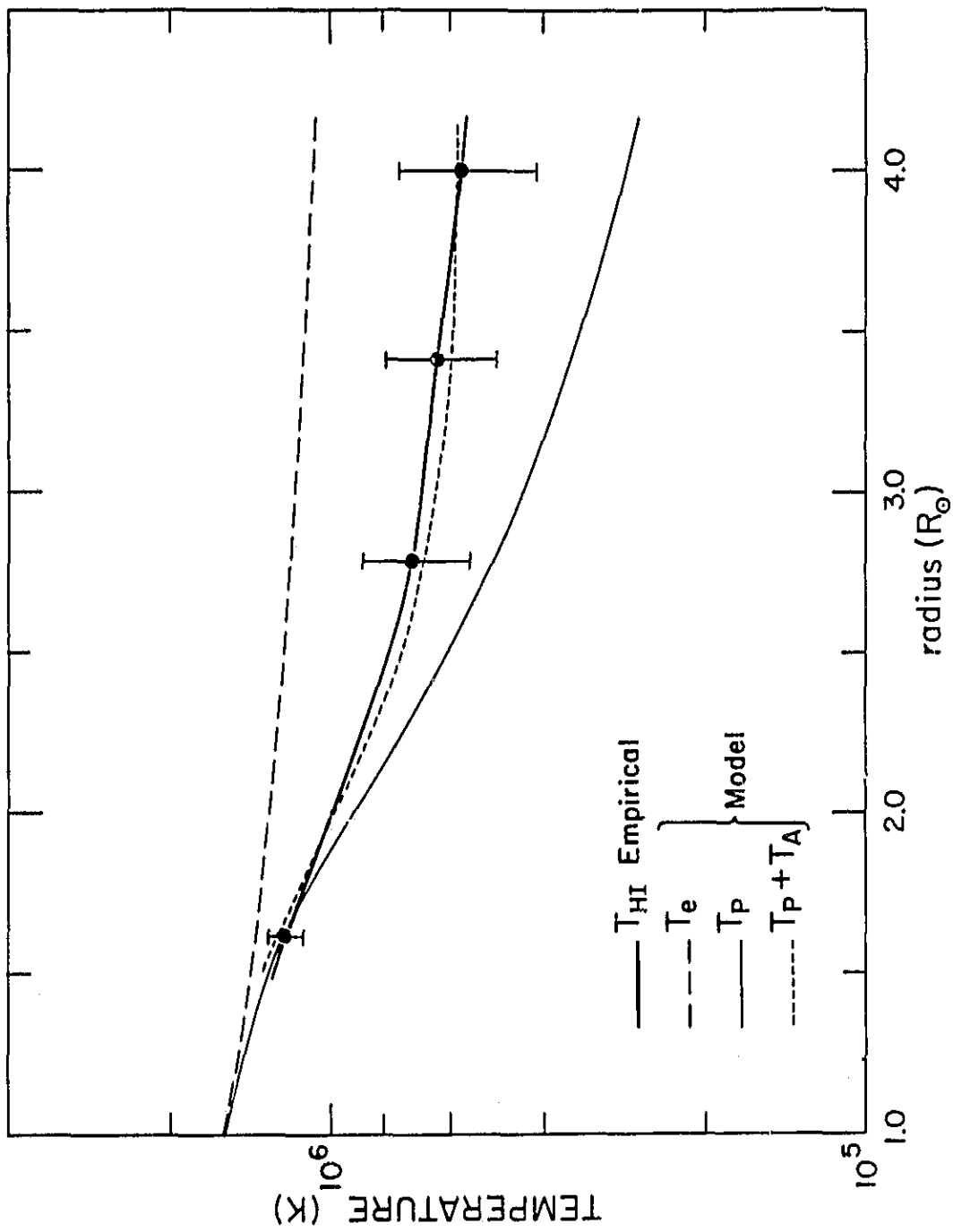

Figure 2-2. A comparison of empirical and measured temperatures in a polar coronal hole (see text).

run of temperature. It should be emphasized that this is a kinetic temperature and includes the effects of both thermal and non-thermal motions broadening the Lyman- α line profiles.

For comparison we have plotted temperatures predicted by a simple two fluid model with no plasma heating above the base of the corona (cf. Hartle and Sturrock, 1968; Nerney and Barnes, 1977; Hollweg, 1978). The short dash line gives the run of electron temperature with radius, while the light solid line gives the predicted proton thermal temperatures. The electron and proton temperature diverge with height due to the rapid decrease in electron-proton coupling with decreasing density. The electron temperature has a shallow temperature gradient due to the high thermal conductivity of electrons, while the proton temperature falls off nearly adiabatically.

Because of the strong coupling between coronal hydrogen atoms and protons in the observed height range, one expects the hydrogen and proton kinetic temperatures to be equal. The difference between the observed coronal hydrogen kinetic temperatures and the calculated proton thermal temperatures indicates that the assumed model is inadequate. One way of bringing the calculated and observed temperatures into agreement is to increase the rms velocity of the protons. There are several ways of accomplishing this. One way is through extended proton heating in the region 1.5 to 4 R_{\odot} . Addition of thermal energy by a mechanism with an energy dissipation length of about 4 R_{\odot} could explain the observations. A similar result was obtained from measurements in an unstructured "quiet" region of the solar corona observed during the 1979 flight of the rocket coronagraphs. See Withbroe *et al.* (1982a) for details.

Propagation of waves could also be contributing to the rms motions of the protons. Consider Alfvén waves which have been suggested as a possible source of energy and momentum for plasma heating and/or solar wind acceleration in coronal holes (see review by Hollweg, 1981). For non-dissipating Alfvén waves Hollweg gives $N^{1/2} \langle v^2 \rangle = \text{constant}$ where v is the rms velocity amplitude of the waves and $N = N_e = N_p$. If the rms velocity is specified at one height, then this relationship can be used to calculate the rms velocity at other heights from the measured variation of density N with height. The dotted line gives the predicted proton kinetic temperature obtained by assuming

$$T_p(\text{kinetic}) = T_p(\text{thermal}) + T_A$$

with

$$T_A = m \langle v^2 \rangle / 2k = m \times \text{constant} / 2kN^{1/2}$$

where the constant was adjusted to give the best fit to the observations. The adopted value of the constant corresponds to $v_{\text{rms}} = 70 \text{ km s}^{-1}$ at $r = 4 R_{\odot}$. This is about one-third the value suggested by Hollweg (1981) for this height.

The fit between the calculated and observed kinetic temperatures is sufficiently good to suggest that plasma motions due to Alfvén waves may be contributing significantly to the broadening of the H I Lyman- α line. The shapes of the line profiles, which are nearly Gaussian, place a constraint on the spectrum of these Alfvén waves, if they are present. It is important to note that there are other explanations for the nearly constant width of the Lyman- α line, such as the above mentioned extended proton heating. In order to distinguish between thermal and non-thermal line broadening mechanisms, additional empirical constraints are needed, such as measurements of spectral line profiles from ions with different masses.

For the three best observed regions in the 1979 and 1980 flights of the Rocket UVC, the measured spectral line widths decrease slowly with increasing

radius for $1.5 \leq \rho \leq 3.5 R_{\odot}$. This indicates that the hydrogen kinetic temperatures were decreasing with increasing radius in the observed regions. Because of the sensitivity of the hydrogen kinetic temperature to energy deposition mechanisms that heat protons, this places tight upper limits on the amount of direct proton heating between $r = 1.5$ and $4 R_{\odot}$ (cf. Withbroe *et al.*, 1982a). The differences in the magnitude of the line widths indicate that significant variations in proton kinetic temperatures between different regions are possible. For example, the kinetic temperature at $r = 1.7 R_{\odot}$ (the mean height of formation of the Lyman- α radiation observed at $\rho = 1.5 R_{\odot}$) is approximately 2.2×10^6 K in the quiet region observed in 1979 and 1.2×10^6 K in the polar coronal hole observed in 1980. Another polar coronal hole observed during the 1979 flight had an intermediate kinetic temperature, 1.8×10^6 K (Kohl *et al.*, 1980), at similar heights.

These few measurements suggest that coronal temperatures in the solar wind acceleration region vary from structure to structure reflecting differing amounts of coronal energy input. This might be expected in light of the variations in plasma heating found at lower levels of the corona (see review by Withbroe and Noyes, 1977). More extensive observations, such as can be obtained by the UVCS/Spartan instrument (Kohl *et al.* 1984) are required before one can seek possible relationships between coronal structure (open or closed magnetic structures, streamers, coronal holes, etc.) and the spatial variations of coronal temperatures determined from a given particle species such as hydrogen atoms.

The ratio of the intensities of the hydrogen Lyman- α line and the white light continuum provides an empirical constraint on solar wind velocities. For the 1980 observations the measured ratio of the intensities of the Lyman- α line and white light continuum was nearly independent of height. This indi-

cates that the flow velocity of the plasma emitting the observed Lyman- α and white light radiations was less than about 150 km s^{-1} , that is, the velocities were sufficiently low enough that the Lyman- α line was not significantly affected by Doppler-dimming (see Figure 2-3). In order to define the limits on the outflow velocities more carefully, the measured Lyman- α intensities were compared with those calculated from a series of coronal models (see Figure 2-4).

The upper curve in Figure 2-4 is for a static atmosphere. The other curves show the predicted Lyman- α intensities for models with different outward particle fluxes parameterized by the velocity at $r = 4 R_{\odot}$. At low heights where the density is high and solar wind velocity is low there is little Doppler dimming. However, due to the steady increase in flow velocity with increasing height, the amount of Doppler dimming increases with height causing the intensity to diverge from that calculated for the static model. A comparison of the calculated intensities with those measured confirms that the amount of Doppler dimming over the observed range of heights is small, corresponding to flow velocities at $r = 4 R_{\odot}$ of less than about 150 km s^{-1} . Given that the sound speed for a corona with $T_e = 1 \text{ to } 1.5 \times 10^6 \text{ K}$ is $130 \text{ to } 160 \text{ km s}^{-1}$, the observations suggest that the solar wind flow in the observed plasma was subsonic for $r \leq 4 R_{\odot}$ and thus that the critical point was at $r \geq 4 R_{\odot}$. Lyman- α measurements in an unstructured "quiet" region of the corona observed in April 1979 also showed little or no Doppler-dimming consistent with subsonic flows for $r \leq 4 R_{\odot}$ (Withbroe *et al.*, 1982a).

Analyses of observations acquired in the 1979 and 1980 flights of the CfA/HAO rocket coronagraphs yields the following empirical constraints on theoretical models for the solar wind acceleration region:

- nearly Gaussian H I Lyman- α profiles

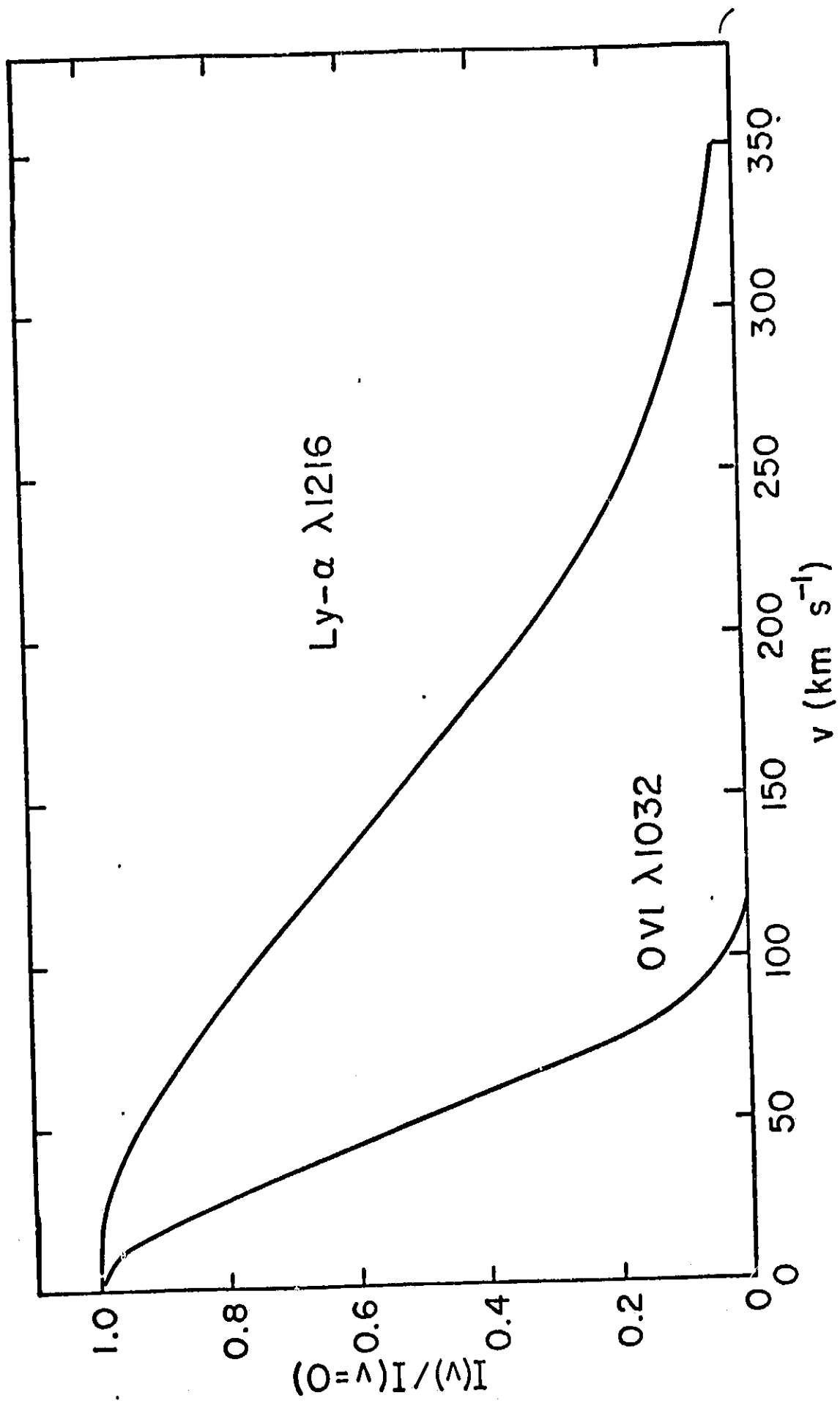

Figure 2-3. Doppler dimming calculated for an isothermal corona with $T = 1.5 \times 10^6$ K.

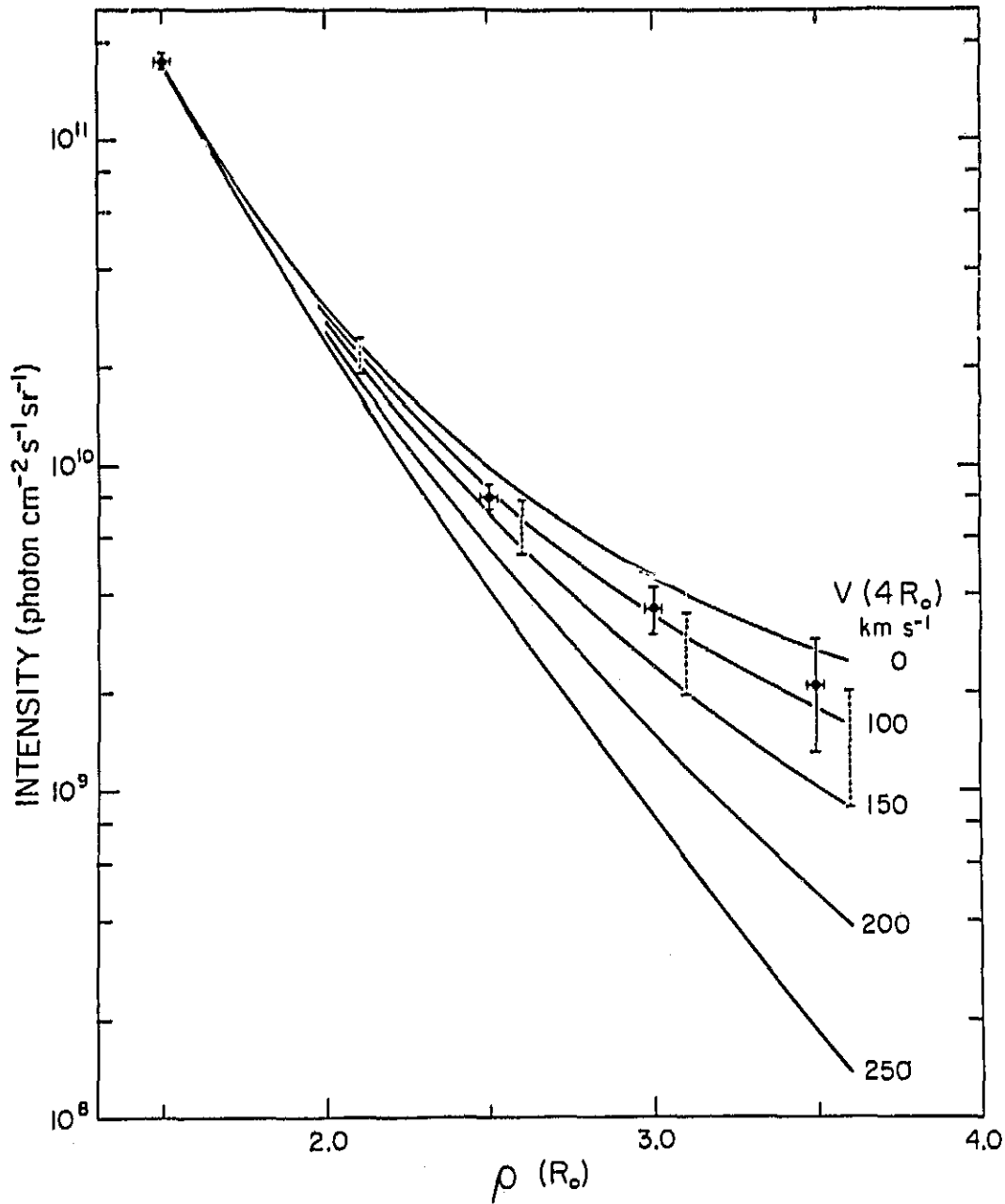

Figure 2-4 A comparison of measured (points) and calculated (curves) H I Lyman- α intensities as a function of distance from sun center. The curves give values calculated for models with different solar wind fluxes parameterized here by the wind velocity at $4 R_{\odot}$ (see text).

- Nearly constant or decreasing hydrogen kinetic temperatures for $1.5 < r < 4 R_{\odot}$
- subsonic flow for $r < 4R_{\odot}$ (critical point at $r \approx 4 R_{\odot}$)
- an upper limit of 140 km s^{-1} for the rms velocity of waves capable of broadening the Lyman- α line for $r \approx 4.0 R_{\odot}$
- some evidence for extended proton heating or a non-thermal contribution to the motions of H I atoms in the observed regions.

For a more detailed discussion of results of the 1979 and 1980 flights of the rocket coronagraph see Kohl *et al.* (1980) and Withbroe *et al.* (1982a,b,c; 1985).

2.2 20 July 1982 Rocket Flight

The rocket observations of 20 July 1982 included observations of a polar coronal hole and of a coronal streamer. Measurements at $1.5 R_{\odot}$ and $2.0 R_{\odot}$ of the H I Lyman- α line profile and the intensity of O VI $\lambda 1032$ and $\lambda 1037$ were made for each of the observed coronal structures.

The primary objective of the 1982 flight was to determine several basic plasma parameters of selected coronal regions within $3.5 R_{\odot}$ of sun center and to verify the new diagnostic techniques for the solar wind acceleration region of the solar corona.

The preliminary analysis of the coronal hole data indicate that the outflow velocity was apparently large enough to cause Doppler dimming of both O VI and H I Lyman- α even at 1.5 and $2.0 R_{\odot}$ where the outflow velocity of the Munro and Jackson model (Munro and Jackson, 1977) is less than 100 km s^{-1} . Velocities greater than 100 km s^{-1} are required to Doppler dim significantly

the H I Lyman- α intensity. Because of the significance of this result, we have undertaken an extremely thorough analysis of the data and we are making extensive post-flight stray light tests and calibrations of the instrument to ensure high confidence in the result.

We have also examined the fractional contributions to observed spectral intensities from a coronal structure of interest similar to the 20 July 1982 coronal hole, which co-exists with other coronal structures along a line-of-sight. The sensitivity of spectroscopic observations (such as the H I Lyman- α line) to physical parameters within the structure of interest has also been studied. The results of this study (Kohl *et al.*, 1983) indicate that the contributions from coronal structures lying in the plane of the solar disc are enhanced over those of neighboring structures along the line-of-sight. Therefore, it is preferable for the coronal structure of interest to be located in this plane at the time of its observation. Measurements of polar coronal holes are particularly advantageous in this respect. Even in the case of a fairly narrow (60°) coronal hole with outflow velocities as large as those in the Munro-Jackson model, the maximum contribution to the observed intensity out to $\rho = 2.2$ was found to be from the coronal hole rather than the surrounding quiet corona. Also, for this example, the observed intensity is highly sensitive to outflow velocity out to beyond $\rho = 2.5$ and the line profile at $\rho = 2.0$ is very sensitive to the hydrogen velocity distribution in the hole. Broader coronal holes such as the 1973 polar hole that was discussed by Munro and Jackson (1977), would dominate observations out to higher heights. Narrower coronal hole-like structures of higher density and smaller outflow velocity, such as the one reported by Withbroe *et al.* (1982b), also provide the dominant contribution out to $\rho = 2.5$.

Line-of-sight contributions tend to be of more concern for observations of coronal holes than for other coronal structures because they have the smallest densities and the highest outflow velocities. For observations of other coronal structures, the fractional contributions tend to be at least as large as the contributions from the coronal holes considered here and other structures tend to be observable at larger heights. The simulated observations that were considered have shown that the primary spectroscopic observables are sensitive to the physical parameters of coronal holes and other structures even in representative cases where the structures of interest are surrounded by other regions along the line-of-sight. The examples used here were for relatively small coronal holes and streamers. Larger structures would provide an even larger fraction of the observed intensities.

REFERENCES

- Gabriel, A.H. (1971) *Solar Phys.* **21**, 392.
- Hartle, R.E. and Sturrock, P.A. (1968) *Astrophys. J.* **151**, 1155.
- Hollweg, J.V. (1978) *Rev. Geophys. Space Phys.* **16**, 689.
- Hollweg, J.V. (1981) in *The Sun as a Star*, NASA SP-450, ed. S. Jordan (NASA, Washington, DC) p. 355.
- Kohl, J.L., Weiser, H., Withbroe, G.L. and Munro, R.H. (1984) in Proceedings of the Eighth International Colloquium on Ultraviolet and X-Ray Spectroscopy of Astrophysical and Laboratory Plasmas, p. 29.
- Kohl, J.L., Weiser, H., Withbroe, G.L., Noyes, R.W., Parkinson, W.H., Reeves, E.M., Munro, R.H. and MacQueen, R.M. (1980) *Astrophys. J.* **241**, L117.
- Kohl, J.L. and Withbroe, G.L. (1982d) *Astrophys. J.* **255**, 263.
- Kohl, J.L., Withbroe, G.L., Weiser, H., MacQueen, R.M. and Munro, R.H. (1981) *EOS Trans. AGU* **62**, 376.
- Kohl, J.L., Withbroe, G.L. and Zapata, C.A. (1983) in Solar Wind V, ed. M. Neugebauer, NASA.
- Munro, R.H. and Jackson, B.V. (1977) *Astrophys. J.* **213**, 874.
- Nerney, S. and Barnes, S.A. (1977) *J. Geophys. Res.* **62**, 3213.
- Withbroe, G.L., Kohl, J.L. and Weiser, H. (1981) *B.A.A.S.* **12**, 917.
- Withbroe, G.L., Kohl, J.L., Weiser, H., Noci, G. and Munro, R.H. (1982a) *Astrophys. J.* **254**, 361.
- Withbroe, G.L., Kohl, J.L., Weiser, H. and Munro, R.H. (1982b) *Space Sci. Rev.* **33**, 17.
- Withbroe, G.L., Kohl, J.L., Munro, R.H. and Weiser, H. (1982c) paper presented at Second Cambridge Workshop on Cool Stars, Stellar Systems and the Sun; published in conference proceedings.
- Withbroe, G.L., Kohl, J.L., Weiser, H. and Munro, R.H. (1985) submitted to *Astrophys. J.*

Withbroe, G.L. and Noyes, R.W. (1977) *Ann. Rev. Astron. Astrophys.* **15**, 363.

3.0 DEVELOPMENT OF UVC INSTRUMENT

3.1 Development of Lyman Alpha Coronagraph

Development of the Lyman Alpha Coronagraph flown on the first two flights was initiated by this grant in July 1976. Prior development of this instrument had been carried out under NASA Grant NSG-7175. Subsequent to July 1976, the detailed design and fabrication of the instrument and its associated Ground Support Equipment (GSE) were completed, and assembly and testing at the subsystem and system levels were carried out.

The basic instrument which is shown in Figure 3-1 consists of the occulted telescope system, the spectrometer, the detector system, the inner support structure, a rocket skin that serves as a vacuum enclosure for the instruments, and an electronics module. Light from the solar disk enters the front aperture, which consists of a rectangular aperture with knife blades, and passes through the instrument to the sunlight trap where it is intercepted by two plane mirrors and reflected into two pyramids where it is absorbed by the walls through multiple reflections. A baffle shields the spectrometer entrance slit from the light trap mirrors. The near sun edge of the entrance aperture serves as a primary occulter which shields the telescope mirror from the bright solar disk. The telescope mirror system consists of an off-axis parabola (with 47 cm focal length) that is coated for maximum reflectance at $\lambda 1216 \text{ \AA}$. The mirror views the corona through the entrance aperture and focuses an image of the corona on the spectrometer entrance slit. The mirror is mounted on a mechanism that rotates the coronal image radially across the slit and also moves the internal occulter which is mounted near the face of the mirror. The internal occulter intercepts diffracted light from the primary occulter that would otherwise enter the spectrometer.

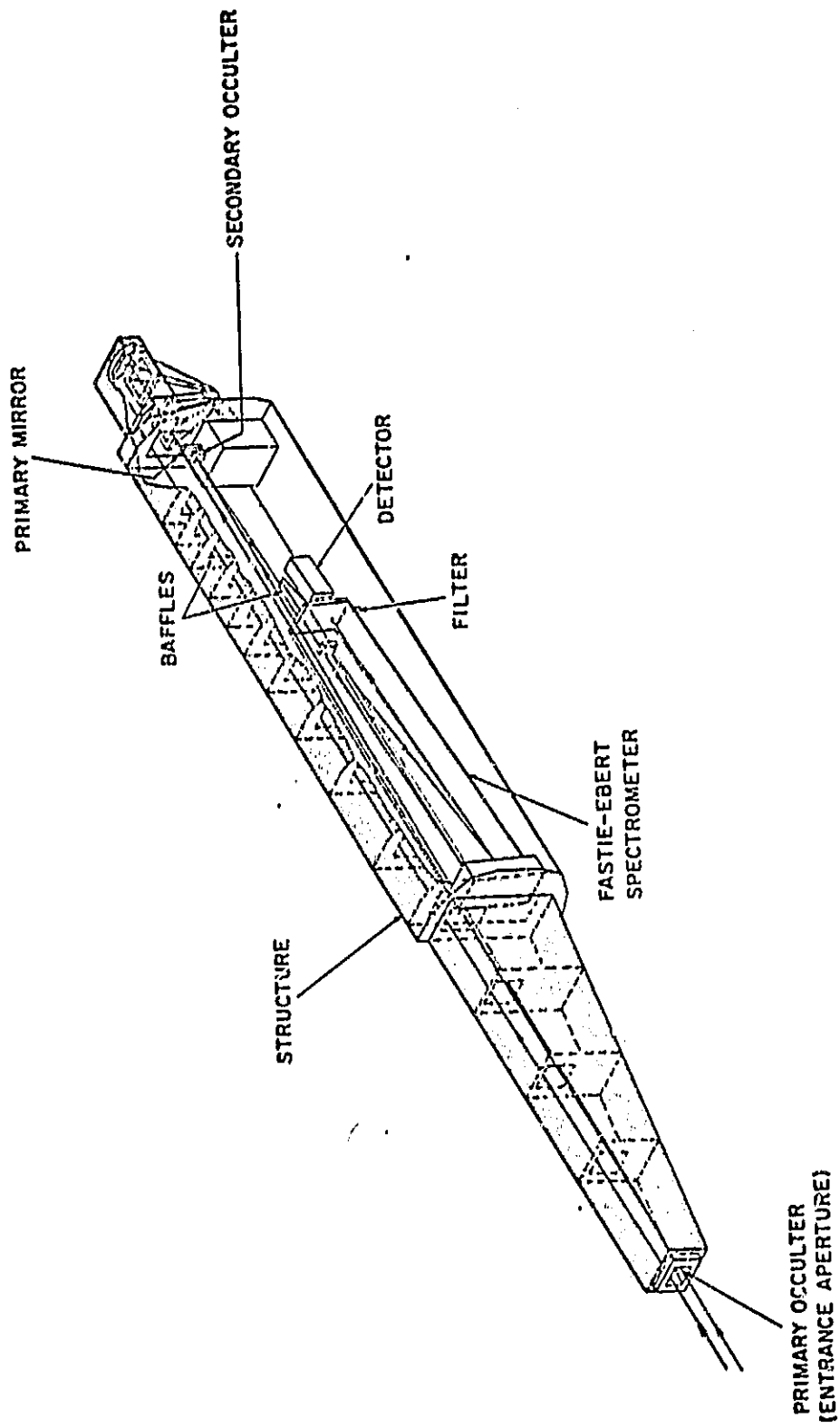

Figure 3-1. Rocket Lyman Alpha Coronagraph.

The spectrometer is a modified version of a 75-cm Fastie-Ebert system that was developed and flown in a previous solar rocket program. The Ebert grating is scanned through a range of 3.0 \AA centered on 1216 \AA to provide measurements of the Lyman- α line profile at each coronal location that is determined by the angle of the telescope mirror and the roll orientation of the rocket payload. The detector for $\lambda 1216 \text{ \AA}$ radiation consists of an EMR 641-G photomultiplier tube with a MgF_2 window and an integrated pulse counting system. Counts from one coronal element at a time were accumulated as a function of wavelength as the Ebert grating scanned the line profile across the exit slit.

The optical/mechanical components of the UV Coronagraph are supported by a monocoque structure that is attached to the HAO instrument. The vacuum enclosure that houses the two instruments consists of standard rocket skins with a pumping port and a pull-away vacuum door.

The final selection of the observational program is determined from ground-based data that is expected to be available on the days immediately prior to launch. The command memory system of the coronagraph can be programmed through the ground support electronics up to one hour before launch. As many as sixteen spatial elements (telescope mirror positions) can be selected. The data accumulation time spent at each location is variable in increments of 6.5 seconds which is the time to carry out one scan of the 3.0 \AA spectral range.

See Figure 3-2 for an electrical block diagram for the Lyman Alpha instrument.

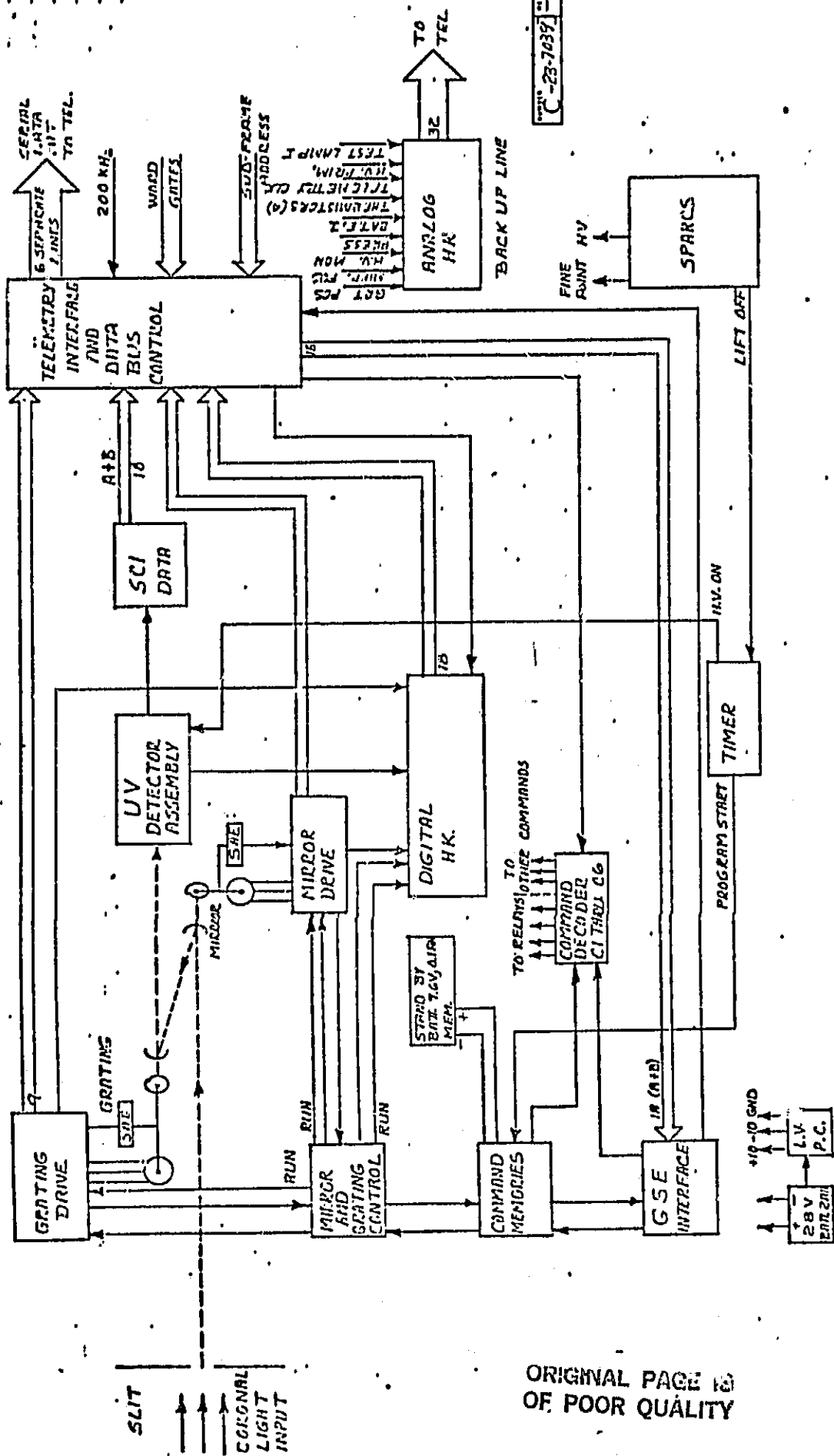

Figure 3-2. Lyman Alpha Coronagraph Block Diagram.

DO NOT SCALE THIS DRAWING UNLESS OTHERWISE SPECIFIED FRACTIONS DECIMALS ANGLES		HARVARD COLLEGE OBSERVATORY 78 MASSACHUSETTS ST.	
TITLE LYMAN ALPHA CORONAGRAPH BLOCK DIAGRAM		DRAWN BY DATE	
CHECKED BY DATE		PROJECT NO. C-23-7039	

ORIGINAL PAGE IS OF POOR QUALITY

3.2 Modifications Made to Lyman Alpha Coronagraph to Permit Measurements of O VI $\lambda 1032$ and $\lambda 1037$

For the third rocket flight, the Lyman Alpha Coronagraph was modified to permit measurement of the integrated intensities of O VI $\lambda 1032 \text{ \AA}$ and $\lambda 1037 \text{ \AA}$ in addition to the coronal intensity and line profile of H I Lyman- α $\lambda 1216 \text{ \AA}$. This modification allowed us to verify the feasibility of making the coronagraphic observations of O VI radiation and provided the first application of the O VI $\lambda 1032/\lambda 1037$ diagnostic technique. A summary of these instrument modifications follows:

3.2.1 Mechanical/Optical Modifications

O VI $\lambda 1032/\lambda 1037 \text{ \AA}$ Spectrometer: The Fastie-Ebert Lyman- α spectrometer case was modified to accommodate the addition of the O VI $\lambda 1032/\lambda 1037 \text{ \AA}$ spectrometer section, which effectively changed the spectrometer into a dual spectrometer as illustrated in Figure 3-3. The lower half of this dual-spectrometer remained optimized for maximum efficiency at $\lambda 1216 \text{ \AA}$ while the upper half was optimized for maximum efficiency at $\lambda 1032/\lambda 1037 \text{ \AA}$. In this system, the Lyman- α light follows the same paths as before except it only uses the lower half of the spectrometer while the O VI light passes through its own separate entrance slit to the osmium coated fixed concave grating which then directs the $\lambda 1032 \text{ \AA}$ and $\lambda 1037 \text{ \AA}$ radiation through the O VI exit slit, past the rotating chopper wheel that selects either $\lambda 1032$ and $\lambda 1037$ and onto the Channel Electron Multiplier (CEM) detector.

The creation of the $\lambda 1032/\lambda 1037 \text{ \AA}$ spectrometer involved the design, fabrication and assembly of (1) the combined Lyman- α /O VI entrance slits and associated slit block assembly, (2) the O VI grating assembly that holds and locks the concave grating into place, (3) the modifications to the spectrome-

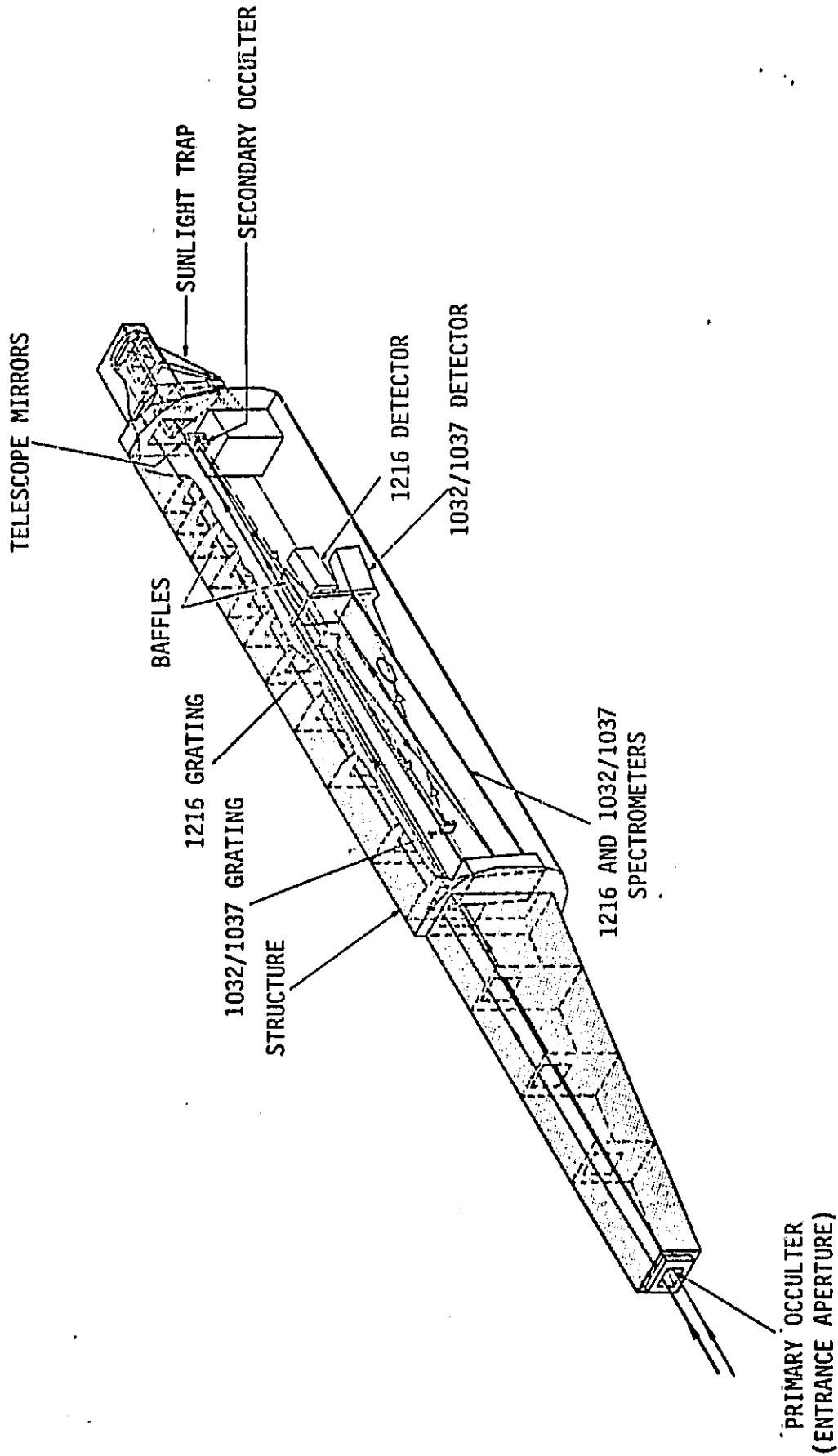

Figure 3-3. Ultraviolet Light Coronagraph for Rocket.

ter box required to accommodate the new entrance and exit slits, grating, detector and chopper mechanism, (4) the additional light baffling both internal and external to the spectrometer required for the $\lambda 1032/\lambda 1037 \text{ \AA}$ spectrometer system and (5) the O VI exit slit and associated slit block assembly.

$\lambda 1032/\lambda 1037 \text{ \AA}$ Chopper Mechanism: The detailed design, fabrication and assembly of a rotating wheel (chopper) assembly was completed. This unit, located on the detector side of the $\lambda 1032/\lambda 1037 \text{ \AA}$ exit slit, alternatively passes $\lambda 1032 \text{ \AA}$ and then $\lambda 1037 \text{ \AA}$ radiation to the CEM detector. The system has been designed such that it is possible to stop the chopper at $\lambda 1032 \text{ \AA}$ using a preprogrammed observing sequence.

CEM Detector Assembly: This detector is a pulse counting channel electron multiplier detection system similar to those used on the Harvard Skylab instrument, and is used to detect both $\lambda 1032 \text{ \AA}$ and $\lambda 1037 \text{ \AA}$ radiation.

Cryo-Vacuum Pump System for O VI Detector: Since the CEM detector is windowless and must be optically baffled but requires a pressure less than about 10^{-5} torr to operate, a separate pumping system with a pumping speed of about 10 l s^{-1} for H_2O was built. This small liquid N_2 cryogenic pumping system, which has a cold block weighing about 2 kg to provide slow warm-up, maintains the required low pressure in the detector vicinity throughout the rocket flight.

Dual Telescope System: The earlier telescope mirror system was modified to provide two separate off-axis parabolas of 47 cm focal length that are coated for maximum reflectance at $\lambda 1216 \text{ \AA}$ and $\lambda 1032 \text{ \AA}/\lambda 1037 \text{ \AA}$, respectively. As can be seen in Figure 3-4, the mirrors view the solar corona through the entrance aperture and focus two co-registered images of the corona on the spectrometer entrance slits so that the entrance slits used for O VI and

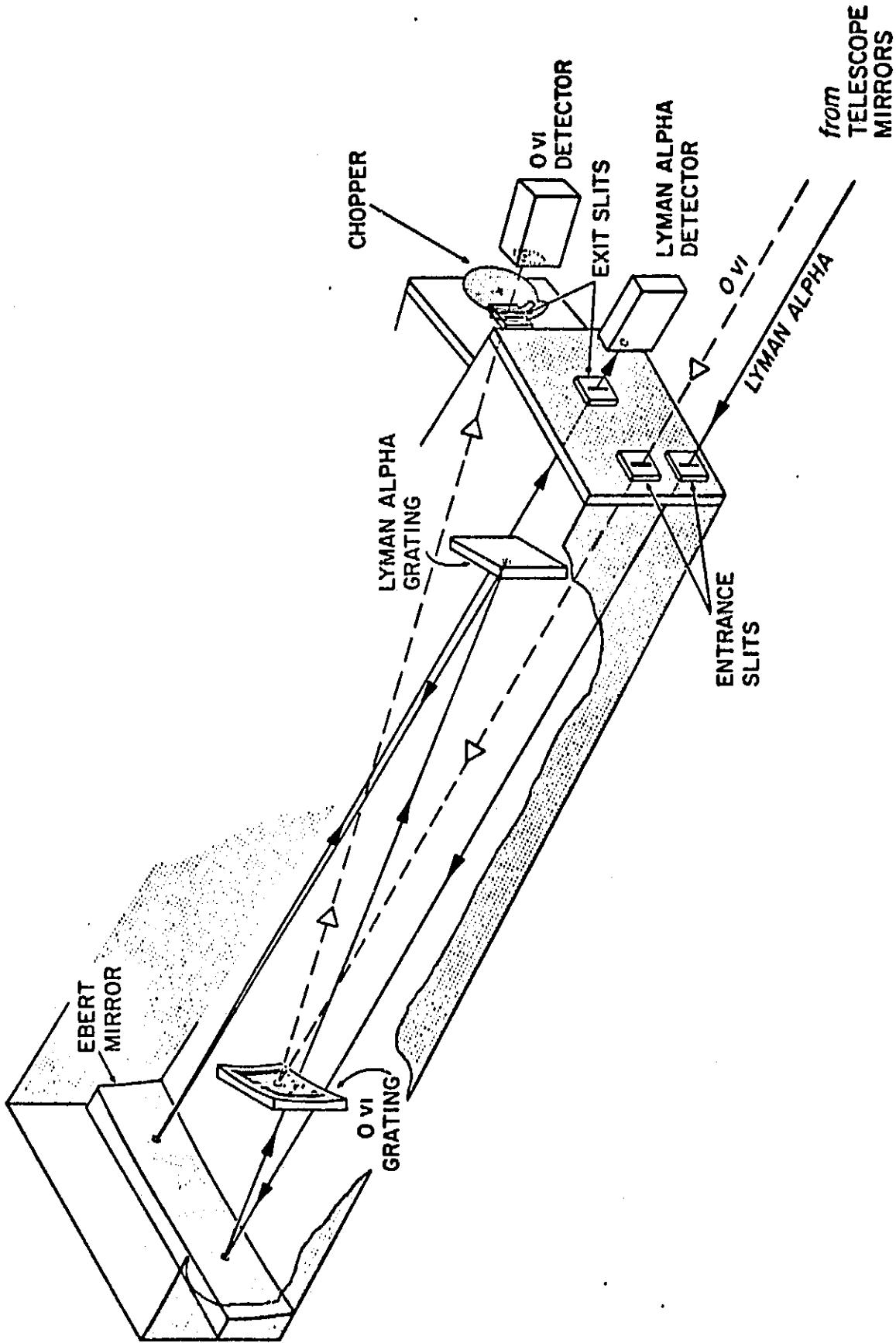

Figure 3-4. Dual-Spectrometer Optical Diagram for Rocket Ultraviolet Light Coronagraph.

Lyman- α both view the same point in the corona. As before, the mirrors are mounted on a mechanism that rotates the coronal images radially across the slits. This mechanism also moves the internal occulter which is mounted near the faces of the mirrors and intercepts diffracted light from the primary occulter that would otherwise enter the spectrometer.

The modified Lyman- α mirror was stripped and recoated with a new Al + MgF₂ coating for optimum reflectance at $\lambda 1216 \text{ \AA}$, whereas the O VI mirror was coated with a developmental, high-reflectance dielectric coating with a measured reflectivity of $\sim 60\%$ at $\lambda 1032/\lambda 1037 \text{ \AA}$.

Miscellaneous Mechanical/Optical Modifications to Instrument: In addition to the major mechanical/optical modifications described above, several other modifications were implemented. These include (1) modification of the sunlight trap, (2) modification of the Lyman- α grating housing to eliminate interference with the O VI light path, (3) refurbishment of the Ebert mirror mount, (4) addition of masks to the Ebert mirror and Lyman- α grating to cover unused portions of their reflective surfaces, (5) modification to the Lyman- α grating drive assembly to eliminate mechanical interference with the O VI exit beam area, (6) modification of the Lyman- α detector electronics housing to accommodate space for the addition of the O VI detector system, (7) replacement of the Lyman- α grating with one of higher reflectivity and (8) modification of the Lyman- α grating cell and drive assemblies.

3.2.2 Electronic Modifications

CEM Detector System: A pulse counting channel electron multiplier detector system for $\lambda 1032/\lambda 1037$ Å observations, along with its associated high voltage power supply, charge amplifier, discriminator, line-driver and accumulator, were designed and fabricated (where required) and installed in the UV Coronagraph.

$\lambda 1032/\lambda 1037$ Å Chopper Drive: A drive and associated control system for the $\lambda 1032/\lambda 1037$ Å chopper mechanism was designed, fabricated and installed on the coronagraph.

Encoders: New brush-type absolute shaft encoders were installed in the telescope mirror drive and Lyman- α grating drive assemblies to replace the earlier units which had become excessively noisy. Corresponding modifications to the existing encoder circuit boards were implemented, and a ± 5 volt power supply was added.

Miscellaneous Electronic Modifications: In addition to the modifications described above, several other modifications were carried out. These included (1) modification of the instrument controller, (2) modification of the data bus controller, (3) modification of the analog housekeeping signal conditioners, (4) modification of the timer circuit for a separate high-voltage turn-on for the O VI detector and (5) the addition of a high-voltage inhibit for the O VI detector.

A block diagram of the electrical system is provided in Figure 3-5. This system consists of the Lyman- α 1216 detector and the O VI 1032/1037 CEM system with count accumulators, telescope mirror drive, Lyman- α 1216 grating drive, the chopper drive, power supplies, the instrument timer, and the telemetry

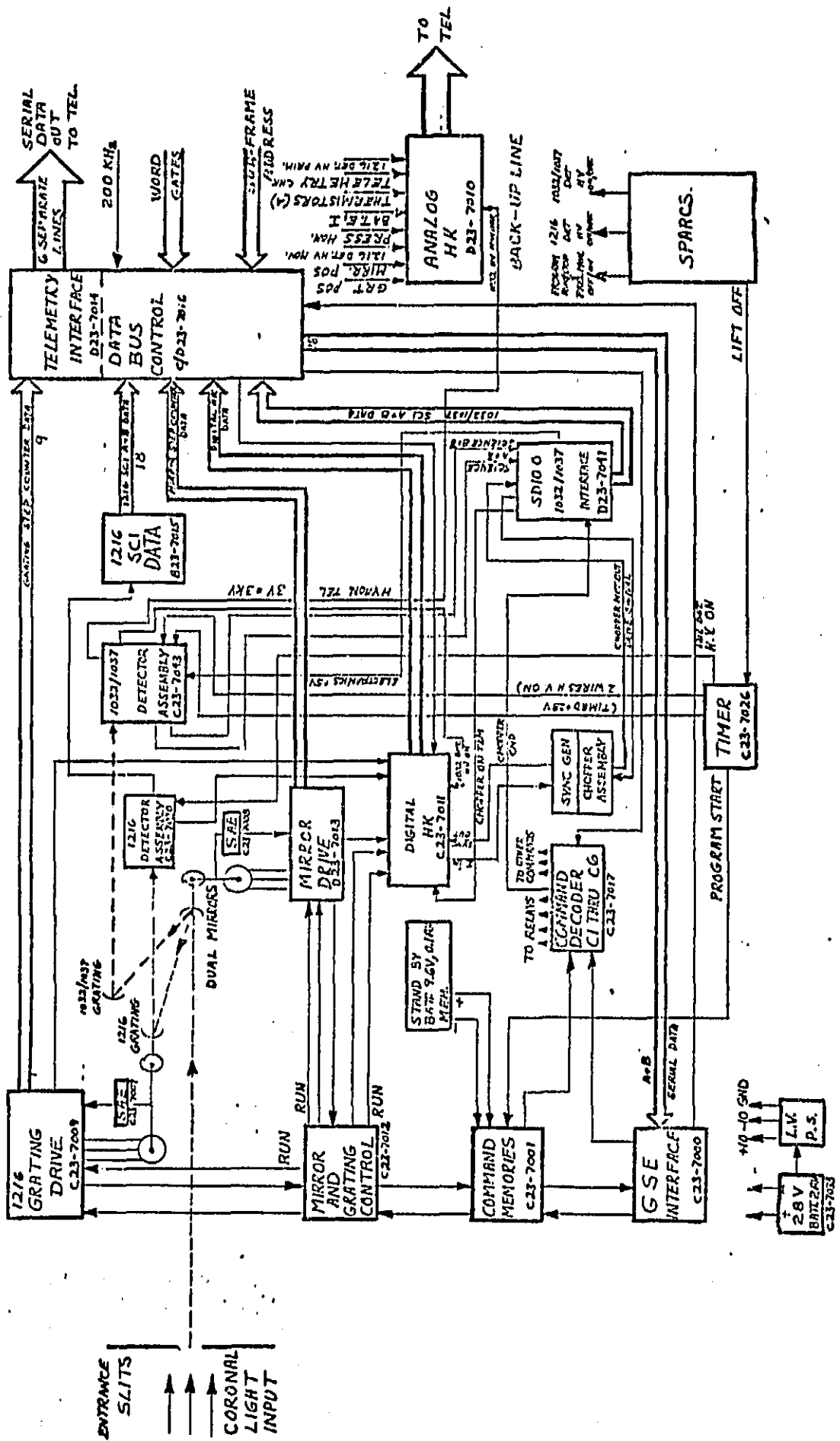

Figure 3-5. Electronics Block Diagram of Rocket Ultraviolet Light Coronagraph.

system.

3.3 Ground Support Equipment

A large vacuum tank and solar simulator test facility was designed and built under this grant. This system, which is used to carry out stray light testing and radiometric calibration of the flight instrument, has been evacuated to a residual pressure of 7×10^{-6} torr with turbomolecular pumps and special liquid nitrogen cryogenic pumps, which are used to improve the pumping speed for water vapor and oxygen. The vacuum tank is 14 meters long and provides 11.6 meters of unobstructed optical path between the external occulter of the flight instrument and the primary mirror of the simulator, which is sufficient to simulate a solar-divergent beam that is large enough to illuminate the full aperture of the coronagraph.