

NASA-CR-3872 19850010714

NASA Contractor Report 3872

Resistance Fail Strain Gage Technology as Applied to Composite Materials

M. E. Tuttle and H. F. Brinson

**COOPERATIVE AGREEMENT NCC2-71
FEBRUARY 1985**

NASA

NASA Contractor Report 3872

Resistance Fail Strain Gage Technology as Applied to Composite Materials

M. E. Tuttle and H. F. Brinson

*Virginia Polytechnic Institute and State University
Blacksburg, Virginia*

Prepared for
Ames Research Center
under Cooperative Agreement NCC2-71

NASA
National Aeronautics
and Space Administration
**Scientific and Technical
Information Branch**

1985

Resistance Foil Strain Gage Technology
as Applied to Composite Materials

by

M. E. Tuttle* and H. F. Brinson*

Abstract

A general review of existing strain gage technologies as applied to orthotropic composite materials is given. The specific topics addressed are gage bonding procedures, transverse sensitivity effects, errors due to gage misalignment, and temperature compensation methods. The discussion is supplemented by numerical examples where appropriate.

It is shown that the orthotropic behaviour of composites can result in experimental error which would not be expected based on practical experience with isotropic materials. In certain cases, the transverse sensitivity of strain gages and/or slight gage misalignment can result in strain measurement errors exceeding 50%.

Introduction

In recent years the use of advanced composite materials has expanded into a wide variety of market places. Products that have been fabricated, at least in part, from composite materials include aircraft structures, space vehicles, rocket motor cases, turbine blades, automobile components, pressure vessels, and a variety of sporting goods. All indications are that composites will become an increasingly important

*Research Associate and Professor, respectively, Virginia Polytechnic Institute and State University, Department of Engineering Science and Mechanics, Blacksburg, VA 24061

structural material system, primarily due to their very high strength-to-weight ratios.

During these developments the stress analyst has been called upon to experimentally determine the mechanical properties of these new material systems. Many of the same experimental methods and techniques used to study conventional isotropic materials have been used to study composite materials which are both orthotropic and heterogeneous. Because most practical experience is based upon the familiar behaviour of isotropic materials, composites can exhibit surprising and unusual behavior which may lead to erroneous interpretation of experimental results.

This paper consists of a review of existing strain gage technologies, as applied to orthotropic composite materials. Although the discussion centers around epoxy-matrix composites, many of the comments made also apply to metal-matrix composites, or for that matter to any orthotropic material.

It should be noted that isolated aspects of this subject have been alluded to by several researchers. For example, Whitney, Daniel, and Pipes [1] have briefly described temperature compensation techniques and the importance of correcting for transverse sensitivity effects, and Chamis and Sinclair [2] have mentioned that gage alignment is of critical importance when testing a 10-deg off-axis tensile specimen. However, to the author's knowledge this is the first time in which many of the important aspects of this subject have been fully documented with analysis and graphs for easy interpretation. In particular, the errors due to misalignment of gages on orthotropic materials have not been fully documented previously, although these effects have been mentioned. Also included is a section on specimen preparation procedures which should prove to be especially useful to the experimentalist.

The specific topics addressed are:

- strain gage selection criteria
- gage bonding procedures
- transverse sensitivity effects
- gage misalignment errors
- temperature compensation methods.

Each of these topics is discussed in a separate section below, followed by a discussion and conclusion section. The effects of orthotropic material behaviour is emphasized throughout, and the discussion is supplemented by numerical examples where appropriate.

Strain Gage Selection Criteria

One of the first steps in any experimental program involving the use of strain gages is selection of the appropriate gage type. In general, the conditions under which the gages will be used must be considered when selecting the strain gage. For general purpose strain gaging, some of the parameters involved in this selection are:

- surface contour of the test specimen
- degree of heterogeneity of test material
- thermal expansion characteristics of test material
- thermal conduction characteristics of test material
- test environmental conditions
- maximum expected strain levels
- maximum expected strain field gradients
- test duration
- stress field characteristics (i.e., unknown biaxial stress field versus known biaxial stress field)
- desired level of measurement accuracy and stability

Generally speaking, epoxy-matrix composites do not place requirements on strain gage capabilities which are more demanding than those posed by other materials. As examples, the heterogeneity of composites is related to the characteristic fiber dimension (about 1 mil in diameter or less) and is not of major concern, composites are generally not used in environments which would be damaging to most strain gage types, and maximum strain levels usually do not exceed 2-3%.

Once the various testing parameters affecting strain gage performance have been identified, a specific gage type may be selected from the multitude of strain gage designs commercially available. This selection will involve specifying (at minimum) the following gage parameters [3]:

- a strain-sensitive gage alloy
- a backing (carrier) material
- a gage length
- a gage pattern
- a self-temperature-compensation number, and
- a gage (grid) resistance

Due to the wide diversity of possible applications, further discussion describing the general process of gage selection is beyond the scope of this paper, and the interested reader is referred to the literature (see for example references 3 or 4). However, there are a few initial considerations common to all strain gage installations involving epoxy-matrix composite materials. These are (at least) gage excitation levels, self-temperature-compensation, and the attachment of leadwires to the gage.

Strain Gage Excitation Levels

It is well known that when strain gages are mounted to polymeric materials the gage excitation level must be kept to a relatively low level. This is because polymeric materials are poor thermal conductors and hence flow away from the gage site is retarded, as compared to most metallic materials. If gage excitation levels are excessive, gage per-

formance is adversely affected in a variety of ways. These include a loss of self-temperature compensation, an increase in hysteresis and creep effects, and a decrease in zero (no load) gage stability [5].

The first effect listed is not particularly important when strain gaging composites, since self-temperature-compensation is not normally used, as will be seen. The second and third factors are important, however, and are directly related to the thermal conductivity of the composite.

The thermal conductivity of the epoxy-matrix alone (referred to as the 'neat resin') is quite low, as would be expected. The effective thermal conductivity of most epoxy-matrix composites is higher than the neat resin, however, due to the relatively high thermal conductivity of the fibers. Nevertheless, gage excitation remains an important consideration.

A detailed discussion of strain gage excitation levels can be found in reference 5. As a general rule, high grid resistances are desired, which allows relatively high bridge excitation levels while still maintaining low gage current levels. This provides for good gage stability while still allowing reasonable gage sensitivity. As a 'ballpark' estimate of acceptable excitation levels, the authors have found that a power density in the range of about 0.31 kilowatts/m² (0.2 watts/in²) to 1.20 kw/m² (0.77 watts/in²) is appropriate for use with graphite-epoxy composites. Having selected an appropriate power density, the bridge excitation level (and gage current) is determined by the specific grid geometry and resistance selected. Using the Micro-Measurement gage EA-06-125AC-350 as an example, the above power densities correspond to excitation levels ranging from about 2 to 4 volts.

Self-Temperature Compensation Number

A strain gage is said to be self-temperature-compensated when the strain gage alloy is processed so as to minimize apparent strain due to temperature effects. The gage manufacturer provides an apparent strain curve with each strain gage which represents the nominal gage response with temperature, when mounted to the appropriate material. This technique normally lowers apparent strains to levels less than about 100 $\mu\text{in/in}$, over a temperature range of about -20 to 205°C (0 to 400°F).

This compensation technique is not well suited for use with composite materials. The major difficulty is that the thermal expansion of composites is in general a highly orthotropic material property, making selection of an appropriate S-T-C number difficult if not impossible. Since S-T-C is not normally used with composites, the selection of the gage S-T-C number becomes somewhat arbitrary; usually a relatively low S-T-C number is selected, e.g., an S-T-C number of 00 or 06.

Attachment of Gage Leadwires

A common concern when attaching leadwires is the possibility of damaging the composite specimen during soldering. This is probably not a problem if a low-temperature solder is used and installation is performed by an experienced technician. However, this may be of concern if a high-temperature solder is used, where the soldering tip temperature may exceed 305°C (580°F), or if inexperienced personnel are used to install the gage. In either case excessive amounts of heat may be introduced into the composite substrate, possibly causing local damage in the form of broken fibers, damaged epoxy matrix, or both. In these instances it is advisable to either purchase strain gages with pre-attached

leadwires, or to solder the lead wires to the strain gage prior to gage installation [6].

Strain Gage Bonding Procedures

The procedures used to adhesively bond strain gages to composite materials are very similar to those used with more conventional structural materials such as steel or aluminum. Composites do require some additional considerations, however, as discussed in the following.

Selection of Adhesive

To the author's knowledge, all commercially available strain gage adhesives are compatible with epoxy-matrix composite materials. However, a concern arises when adhesives requiring an elevated-temperature cure cycle are used. Among the possible problems in these cases are:

- The glass-transition temperature (T_g) of epoxy-matrix composites is typically in the range of 120-177 °C (250-350 °F), whereas many of the elevated temperature adhesives are normally cured at or above these temperatures. If the temperature of an unconstrained composite specimen is near (for a long time) or above (for a short time) the T_g during curing, specimen warping often occurs.
- Many of the mechanical properties of polymeric materials, especially the viscoelastic properties, are dramatically affected by previous thermal excursions at or near the T_g [7]. To assure representative and repeatable material response, composite specimens are often subjected to a carefully controlled post-cure thermal cycle [8,9,10]. This careful thermal conditioning can be destroyed if a gage assembly is subsequently cured at temperatures near the T_g .

These potential difficulties can often be avoided by using the lowest curing temperatures possible with the adhesive system being used, which usually necessitates long curing times. As an example, appropriate curing times vs. curing temperatures published by Micro-Measurements for the M-Bond 600 adhesive system are shown in Figure 1 [11]. Both a 'recommended' cure cycle and a 'minimum' cure cycle are indicated. The authors have found that for gages bonded to T300/5208 graphite-epoxy, with a T_g of about 163 °C (325 °F), M-Bond 600 cured at 85°C (185 °F) for a period of 8 hrs or greater will provide a very satisfactory adhesive bond, while still avoiding any perturbation of the careful thermal conditioning these specimens are subjected to during preparation. Thus, the lower cure temperature avoids the potential problems described above. This approach must be used with caution however, because if the cure temperature is too low, the epoxy adhesive will not form a properly gelled glass during cure but rather a weak and brittle ungelled glass [12]. Therefore, in some cases it may be necessary to incorporate the adhesive cure cycle with the post-cure cycle.

Surface Preparation

In conventional strain gage practice, the specimen surface is usually abraded so as to provide a surface appropriate for adhesive bonding. The amount of abrasion required depends of course on the original condition of the surface. For general-purpose strain gaging, a surface finish in the range of 1.6-3.2 $\mu\text{m rms}$ (63-125 $\mu\text{in rms}$) is normally recommended [13].

Many composites are routinely produced with a very smooth surface finish, and require very little (if any) surface abrasion. In other

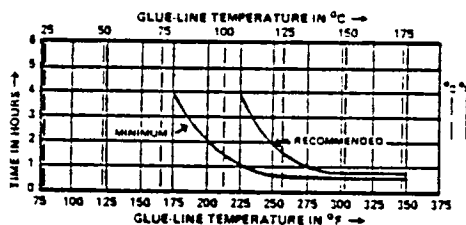

Figure 1: Recommended curing times and temperatures for the M-Bond 600 strain gage adhesive system [11].

cases a cloth-like pattern is imprinted on the surface of the composite during fabrication by the scrim cloth. This relatively rough surface usually requires some preparation prior to strain gage bonding, although strain gages have been successfully bonded directly to this surface for tests conducted at room temperature [14]. For tests conducted at even moderately elevated temperatures the cloth-like surface pattern can result in bond failure, however.

Two methods to provide a surface suitable for adhesive bonding were investigated by Yeow [15], and further refined and reported by Griffith, et al. [14]. The first was to apply an epoxy precoat (EpoxyLite 5403) to fill the surface irregularities. It was thought that this procedure was advantageous in that it avoided any possible damage to the composite due to more conventional surface abrasion. While this procedure did eliminate bond failure, the resulting bond line was relatively thick, resulting in high levels of adhesive creep, particularly at elevated temperatures. Therefore, a second method of surface preparation was investigated, which did involve very light surface abrasion, using 320-400 grit paper. With this technique 1-2 mils of material is removed from the specimen surface, resulting in an acceptably smooth surface. The

thin surface layer removed is a resin-rich area, and a slight change in mechanical properties due to this abrasion was anticipated. No changes could be detected, however, and this method proved to be the superior procedure. It should be emphasized that abrasion must be kept to a minimum, however, to avoid possible damage to fibers in the outer ply of the composite laminate.

The general procedures followed during surface preparation is as follows:

- Initial cleaning of the specimen using propanol or freon,
- Light surface abrasion using 320-400 grit paper (if required)
- Thorough cleaning of the specimen using propanol or freon, M-Prep Conditioner A, and M-Prep Neutralizer 5.

Following surface preparation the gage is mounted to the specimen, using the procedures recommended for the adhesive being used. At times there is a concern that water-based cleaning agents may increase specimen moisture content, particularly if an adhesive which is cured at room temperature (rather than at an elevated temperature) is used. In these cases it is advisable to heat the specimen to a moderately high temperature for a few hours prior to gage bonding.

Note that it is not possible to use burnished alignment marks to aid in strain gage alignment, as is common practice with conventional structural materials such as steel or aluminum. Subsequently, strain gages are often mounted 'by eye.' It will be shown later in this paper that misalignment errors of only a few degrees can produce large errors in strain measurement under certain conditions. Hence, the practical difficulties associated with gage alignment will be seen to be of some importance.

Transverse Sensitivity Effects

The term 'transverse sensitivity' refers to the fact that a strain gage will in general respond to a strain field acting perpendicular to the major axis of the gage. This effect is due to a variety of factors, including grid geometry, gage alloy, gage backing and encapsulation materials, and several manufacturing variables. Transverse sensitivity is an undesirable effect, since it results in a strain reading which is a combination of the gage response to both axial and transverse strains. As several authors have noted [1,2], strain measurements obtained using strain gages mounted to composite materials are especially susceptible to transverse sensitivity errors. This propensity towards error is directly due to the highly orthotropic behaviour of composite materials, as will be shown below.

An excellent review of the data reduction procedures used to correct for transverse sensitivity was recently presented in reference 16. Therefore, a limited review of the concepts involved in correcting for transverse sensitivity will be given here, and the reader is referred to reference 16 if greater detail is desired.

When a strain gage is exposed to a strain field, a small change in grid resistance occurs, which is given by

$$\frac{\Delta R}{R} = F_a \epsilon_a + F_t \epsilon_t \quad (1)$$

where:

ΔR = change in gage resistance

R = original gage resistance

ϵ_a = strain parallel to major axis of gage

ϵ_t = strain perpendicular to major axis of gage

F_a = axial gage factor

F_t = transverse gage factor

The transverse sensitivity coefficient of the strain gage is defined as:

$$K = \frac{F_t}{F_a} \quad (2)$$

This coefficient is one of the calibration parameters supplied by strain gage manufacturers with each strain gage. The value of K is normally within a range of about -0.05 to 0.05 . (Note that gage manufacturers customarily report K as a percentage value, so the range of K as reported by gage manufacturers is from -5% to 5%).

Equation (1) can now be written in terms of K :

$$\frac{\Delta R}{R} = F_a (\epsilon_a + K \epsilon_t) \quad (3)$$

During calibration of the strain gage by the manufacturer, the strain gage is mounted to a standard calibration material and subjected to a uniaxial stress field. The major axis of the strain gage is parallel to the stress field. Under these conditions, the transverse strain applied to the gage is due to the Poisson effect, and is equal to:

$$\epsilon_t = -\nu_0 \epsilon_a$$

and Equation (3) can be written for this case as:

$$\frac{\Delta R}{R} = F_a (1 - \nu_0 K) \epsilon_a \quad (4)$$

where

ν_0 = Poisson's ratio of the calibration material used by the gage manufacturer (normally $\nu_0 = 0.285$)

Finally, the 'gage factor' supplied by the manufacturer is defined as:

$$F_g = F_a(1 - \nu_0 K) \quad (5)$$

Under strain conditions in which transverse sensitivity effects are negligible, the strain measured by a strain gage is given by the familiar equation

$$\epsilon_m = \frac{\frac{\Delta R}{R}}{F_g} \quad (6)$$

However, if the strain field is such that transverse effects are not negligible, then Eq. (6) is not applicable, and at least two orthogonal strain measurements are required to correct for transverse sensitivity errors. Denoting the two measured strains as ϵ_{mx} and ϵ_{my} , the true strains in the x- and y-directions are given by:

$$\epsilon_x = \frac{(1 - \nu_0 K)(\epsilon_{mx} - K\epsilon_{my})}{1 - K^2}$$

$$\epsilon_y = \frac{(1 - \nu_0 K)(\epsilon_{my} - K\epsilon_{mx})}{1 - K^2}$$

These are the standard correction equations used with 2-element rectangular rosettes. Note that it has been tacitly assumed that K has the same value for each gage element. See reference 16 for the correction equations allowing independent K values, and also for the correction equations used with rectangular or delta 3-element rosettes.

The effects of orthotropic material behaviour on transverse sensitivity effects can be investigated most easily by considering the error which would occur if transverse sensitivity is not taken into account. The error in the measured strain introduced by transverse sensitivity can be expressed as

$$\text{error} = \frac{K\left(\frac{\epsilon_t}{\epsilon_a} + \nu_0\right)}{(1 - \nu_0 K)} \times 100\% \quad (7)$$

Consider a simple uniaxial tensile test of an isotropic material, and suppose a strain gage is mounted to the test specimen transverse to the load direction. For this case the ratio (ϵ_t/ϵ_a) in Eq. (7) is equal to $(-1/\nu)$, where ν is Poisson's ratio for the isotropic material. Since ν ranges from about 0.20 to 0.40 for most structural materials, the error due to transverse sensitivity ranges from about -4.7 to -2.2%, where values for K and ν_0 of 0.01 and 0.285, respectively, were used. Now consider a uniaxial tensile test of a 90-deg unidirectional composite specimen, again with a gage mounted transverse to the load direction. The ratio (ϵ_t/ϵ_a) in Eq. (7) now becomes $(-1/\nu_{21})$. While ν_{21} can vary over a wide range, it is commonly on the order of 0.01 to 0.05. Hence, the error due to transverse sensitivity (using the same values for K and ν_0 as before) ranges from -100.0 to -19.8%. The increase in error is directly attributable to the very low values of ν_{21} .

To further illustrate these effects, the three loading conditions shown in Figure 2 were considered. In Fig. 2(a), a strain gage is shown mounted to an isotropic material, subjected to a uniaxial stress field. The major axis of the gage is oriented an angle θ from the loading direction. In Figure 2(b) a similar loading condition is defined for a

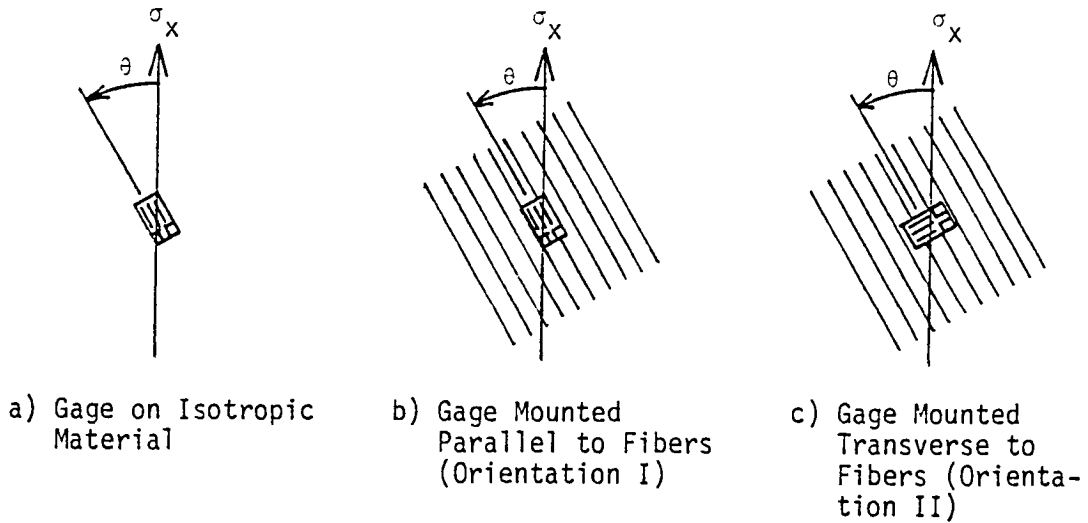

Figure 2: Assumed loading configurations illustrating transverse sensitivity effects.

unidirectional composite lamina, where both the lamina fibers and the major axis of the strain gage are oriented an angle θ from the load direction. This orientation will be referred to as orientation I. Finally, Figure 2(c) defines a load case in which the fibers of a unidirectional composite lamina are oriented an angle θ from the load direction, and a strain gage is mounted perpendicular to the fibers. This load case will be referred to as orientation II. For each condition, the strain measured by the gage without transverse sensitivity corrections will be compared to the actual strain in the direction of the strain gage. The materials considered will be steel for the isotropic case and graphite-epoxy for the orthotropic case. Assumed material properties are given in Table 1. A uniaxial stress level of $\sigma_x = 68.95$ MPa (10,000 psi) and a transverse sensitivity coefficient of $K = 0.03$ will be used. Note that this stress level is probably somewhat higher than the ultimate strength of a 90-deg specimen of Gr/Ep, although it is much less than the ultimate strength of a 0-deg specimen. Since this numerical

	E_1	E_2	ν_{12}	G_{12}	α_1	α_2
MATERIAL	psi $\times 10^6$	psi $\times 10^6$	psi $\times 10^6$	psi $\times 10^6$	$\mu\text{in/in}/^\circ\text{F}$	$\mu\text{in/in}/^\circ\text{F}$
STEEL	30.0	--	0.285	11.67	6.0	--
GRAPHITE- EPOXY	30.0	0.75	.250	0.375	0.1	15.0

Table 1: Typical material properties for steel and graphite epoxy

example is intended to illustrate the effects of transverse sensitivity only, the specific level of stress is unimportant and the level chosen is merely for convenience.

The actual axial and transverse strains in the direction of the strain gage (denoted ϵ_a and ϵ_t) can be easily determined for any angle θ using standard mechanics of materials calculations (see for example reference 17). For an isotropic material, the axial and transverse strains are given by

$$\epsilon_a = \frac{\sigma_x}{2E} [1 - \nu + \cos 2\theta (1 + \nu)]$$

$$\epsilon_t = \frac{\sigma_x}{2E} [1 - \nu - \cos 2\theta (1 + \nu)]$$

For an orthotropic composite material, the axial and transverse strains are given by

$$\epsilon_a = \sigma_x [\bar{S}_{11} \cos^2 \theta + \bar{S}_{12} \sin^2 \theta + 2 \cos^2 \theta \sin^2 \theta \bar{S}_{16}]$$

$$\epsilon_t = \sigma_x [\bar{S}_{11} \sin^2 \theta + \bar{S}_{12} \cos^2 \theta - 2 \cos^2 \theta \sin^2 \theta \bar{S}_{16}]$$

where

\bar{S}_{ij} = the "transformed reduced compliance matrix"

$$\bar{S}_{11} = S_{11}\cos^4\theta + (2S_{12} + S_{66})\sin^2\theta\cos^2\theta + S_{22}\sin^4\theta$$

$$\bar{S}_{12} = S_{12}(\sin^4\theta + \cos^4\theta) + (S_{11} + S_{22} - S_{66})\sin^2\theta\cos^2\theta$$

$$\bar{S}_{16} = (2S_{11} - 2S_{12} - S_{66})\sin\theta\cos^3\theta - (2S_{22} - 2S_{12} - S_{66})\sin^3\theta\cos\theta$$

$$S_{11} = \frac{1}{E_1} \qquad S_{22} = \frac{1}{E_2}$$

$$S_{12} = -\frac{\nu_{12}}{E_1} \qquad S_{66} = \frac{1}{G_{12}}$$

Given that ϵ_a and ϵ_t are known, an expression for the measured strain ϵ_m can be obtained by substituting Eqs. (3) and (5) into Eq. (7), which results in:

$$\epsilon_m = \frac{(\epsilon_a + K\epsilon_t)}{(1 - \nu_0 K)}$$

The results for the case of steel are presented in Figure 3. As would be expected, the difference between the measured and actual strain is a maximum at an angle of $\theta = 90$ deg. The error is seen to increase uniformly with θ , and unless a very high degree of accuracy is required, the transverse sensitivity effects in this case would probably be neglected.

The results for the graphite-epoxy specimens are presented in Figures 4 and 5. It is seen in Figure 4 that for the case of orientation I significant errors are introduced at fiber/gage angles ranging from

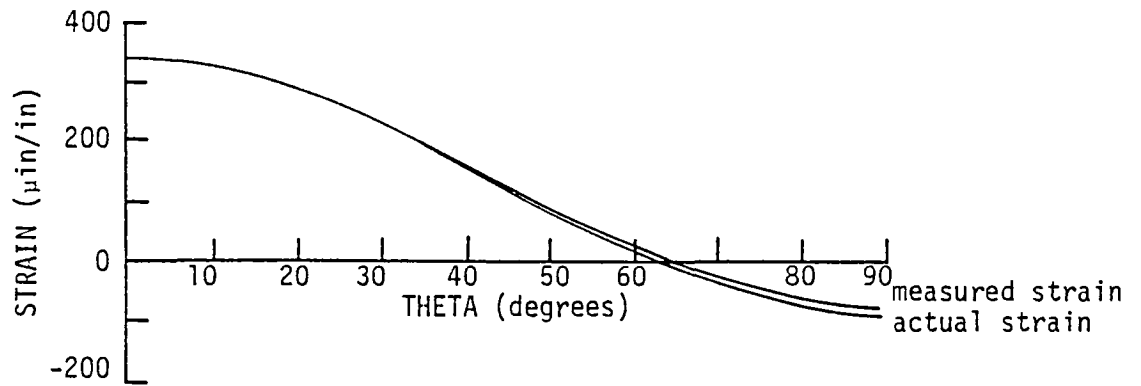

Figure 3: Error due to transverse sensitivity effects for steel;
 $K = 0.03$

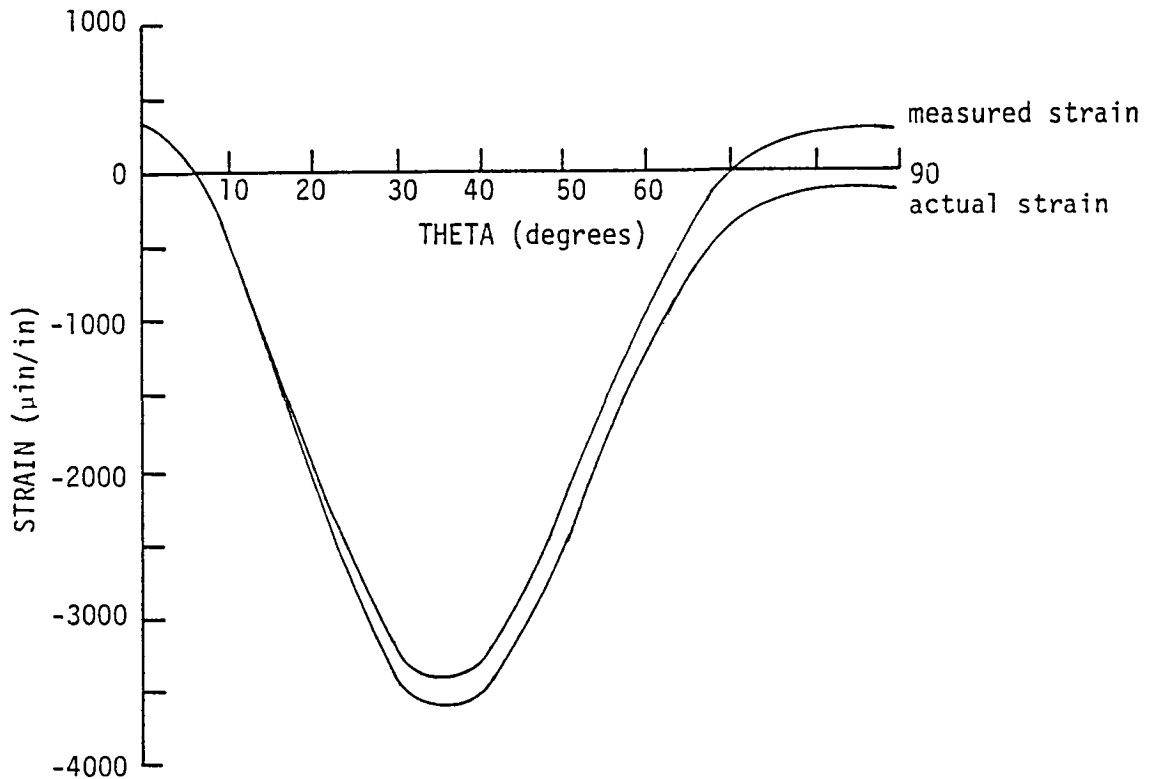

Figure 4: Error due to transverse sensitivity effects for graphite/
 epoxy, orientation I; $K = 0.03$.

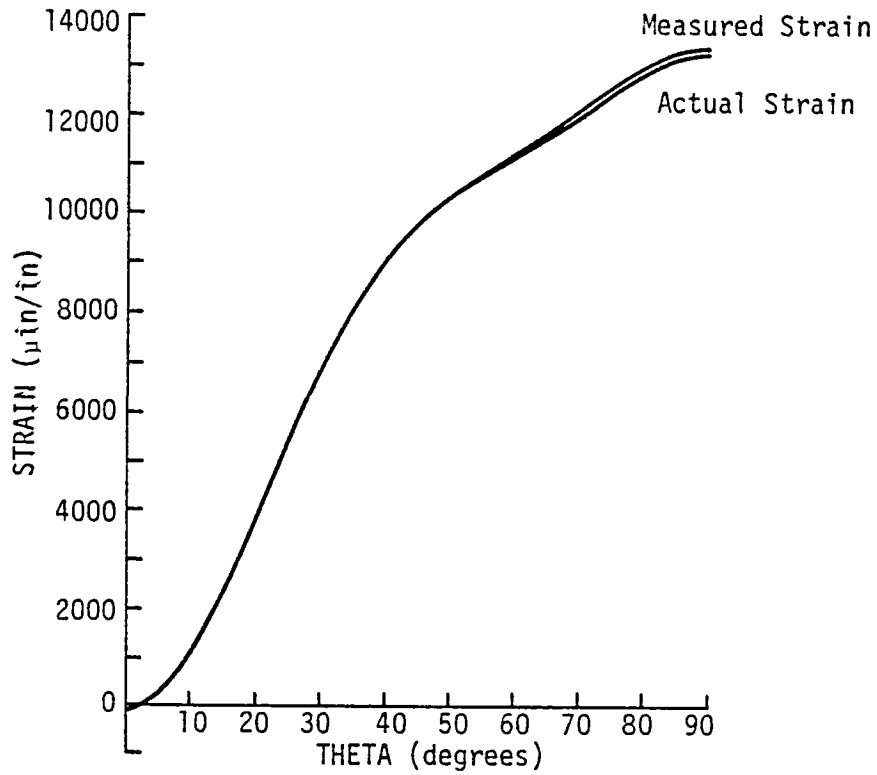

Figure 5. Error due to transverse sensitivity effects for graphite/epoxy; orientation II; $K = 0.03$

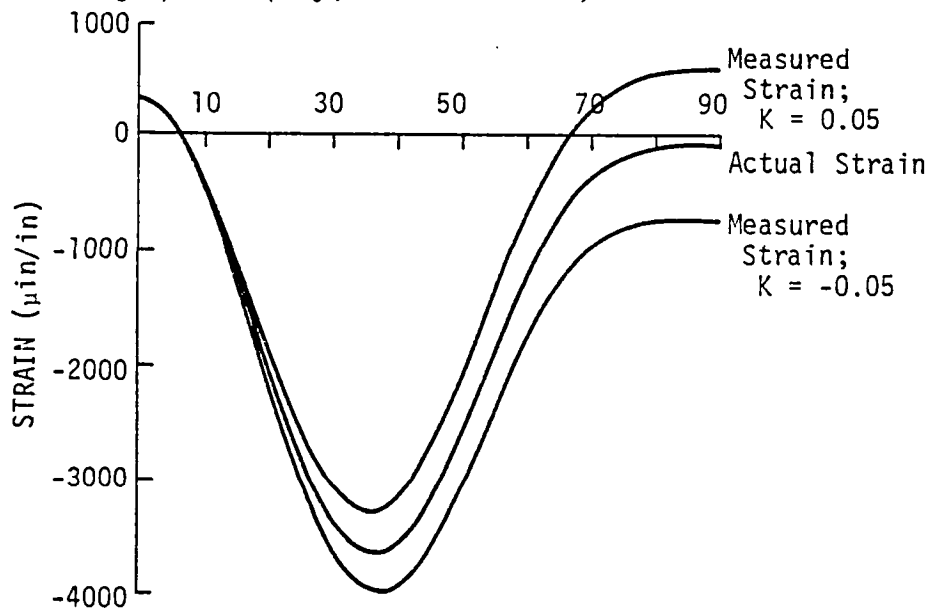

Figure 6. Errors due to transverse sensitivity effects for graphite/epoxy

about 30-deg to 90-deg. Although one might have anticipated significant error at $\theta = 90$ -deg, the errors for angles as low as $\theta = 30$ -deg are somewhat surprising. On the other hand, results presented in Figure 5 for orientation II indicate transverse sensitivity errors as low as those encountered in the isotropic case. It is interesting to note that as a general rule, transverse sensitivity errors are most severe for unidirectional composite lamina when the strain gage is mounted parallel or nearly parallel to the fibers.

As previously mentioned, K values range from about -0.05 to 0.05. In Figure 6 a comparison is made between the actual strain and measured strain for K values of -0.05 and 0.05, for graphite-epoxy, orientation I. This result serves to emphasize that when applying strain gages to composite materials transverse sensitivity effects must always be considered, and that under certain conditions transverse sensitivity effects can completely dominate the actual strain to be measured.

Errors Due to Gage Misalignment

A common method of gage alignment when mounting strain gages to conventional structural materials is to first burnish alignment marks on the specimen surface during initial specimen preparation. These alignment marks are usually applied using a relatively blunt-tipped instrument, such as a 4-H drafting pencil or a ball-point ink pen. The strain gage is then aligned using these marks, often with the aid of a short length of transparent tape. While this procedure is quite satisfactory for general purpose strain gage applications, gage alignment cannot be guaranteed to tolerances better than about ± 1 to 2 degrees from the intended gage direction. Under most conditions gage misalignments of 1 to 2 degrees produce negligible measurement errors when mounted to an isotropic material. For a single strain gage mounted to an isotropic material and subjected to a uniform biaxial strain field, the magnitude of the error due to misalignment depends upon three factors (ignoring transverse sensitivity effects) [18]:

- The ratio of the algebraic maximum to the algebraic minimum principal strains
- The angle ϕ between the maximum principal strain axis and the intended axis of strain measurement
- The angular mounting error, β , between the gage axis after bonding and the intended axis of strain measurement.

These three general conclusions for isotropic materials also hold for composite materials. However, as in the case of transverse sensitivity effects, the orthotropic nature of composites serve to produce

results quite different from those for isotropic materials. For example, consider a uniaxial tensile specimen of an isotropic material. Suppose it is intended to mount a gage along the major axis of the specimen, but the gage is misaligned some small amount, say an angle β_0 . Since the specimen material is isotropic, the principal strain directions coincide with the principal stress directions, and hence the gage is aligned very closely with the principal strain directions, since β_0 is small. The error due to misalignment is therefore small. Now consider a uniaxial tensile specimen of an off-axis composite lamina, i.e., a tensile specimen consisting of a unidirectional composite material whose fibers are at an angle θ away from the major axis of the specimen. Again let an axial gage be misaligned a small angle β_0 . Since the off-axis composite specimen is orthotropic, the principal strain directions do not in general coincide with the principal stress directions. Hence, the angle ϕ between the maximum principal strain axis and the intended axis of strain measurement is much larger in the orthotropic case than in the isotropic case. The same small misalignment error therefore produces a much larger error in strain measurement for the composite case than for the isotropic case.

As previously mentioned, the use of burnish marks to aid in gage alignment is not possible with epoxy-matrix composites, and hence gages are often mounted to tensile specimens 'by eye.' The cloth-like pattern left by the scrim cloth on many composites can also be misleading, as one is tempted to align the gage using this pattern as a guide, yet this pattern does not necessarily reflect the true fiber direction. These considerations indicate that unless further precautions are taken, gage alignments on composites cannot be held to tolerances better than about ± 2 to 4 degrees from the intended gage direction.

Given that misalignment errors of these magnitudes can easily occur when using conventional gage mounting techniques, the error in strain measurement due to possible misalignment may be easily calculated. Consider the two uniaxial load cases shown in Figure 7. In Figure 7(a), an axial strain gage has been mounted to a θ -deg off-axis tensile specimen. The gage is assumed to be misaligned by the angle β . A similar condition is shown for a transverse strain gage in Figure 7(b). These two cases will be used to assess the error in strain measurement due to the gage misalignment, β . In practice, the strains measured by the gages would have to be corrected for transverse sensitivity effects, as previously shown. To avoid undue complication of this example, transverse sensitivity effects will be ignored, i.e., K will be set equal to zero.

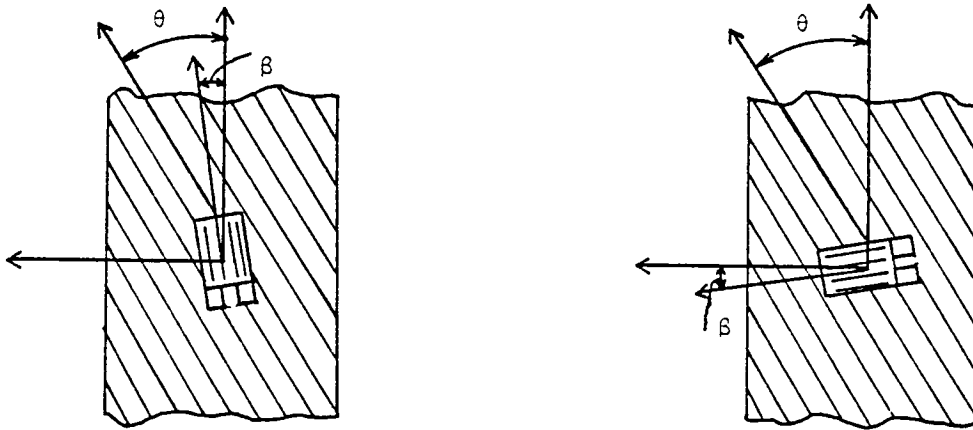

a) Axial gage misaligned by an angle β

b) Transverse gage misaligned by an angle β

Figure 7: Assumed loading configurations illustrating gage misalignment effects

The actual axial and transverse strains, ϵ_x and ϵ_y , acting in the x - and y -directions may be determined through Hooke's law for an orthotropic composite material [17]:

$$\begin{pmatrix} \epsilon_x \\ \epsilon_y \\ \gamma_{xy} \end{pmatrix} = \begin{bmatrix} \bar{S}_{11} & \bar{S}_{12} & \bar{S}_{16} \\ \bar{S}_{12} & \bar{S}_{22} & \bar{S}_{26} \\ \bar{S}_{16} & \bar{S}_{26} & \bar{S}_{66} \end{bmatrix} \begin{pmatrix} \sigma_x \\ 0 \\ 0 \end{pmatrix}$$

or, for this case:

$$\begin{pmatrix} \epsilon_x \\ \epsilon_y \\ \gamma_{xy} \end{pmatrix} = \sigma_x \begin{pmatrix} \bar{S}_{11} \\ \bar{S}_{12} \\ \bar{S}_{16} \end{pmatrix}$$

Since the strain gages have been misaligned by the small angle β , the strains measured by the gages are not the actual axial and transverse strains ϵ_x and ϵ_y , but rather the strains ϵ'_x and ϵ'_y , found by rotating the strain vector through an angle β :

$$\begin{pmatrix} \epsilon'_x \\ \epsilon'_y \\ \gamma'_{xy}/2 \end{pmatrix} = \begin{bmatrix} m^2 & n^2 & 2mn \\ n^2 & m^2 & -2mn \\ -mn & mn & m^2 - n^2 \end{bmatrix} \begin{pmatrix} \epsilon_x \\ \epsilon_y \\ \gamma_{xy}/2 \end{pmatrix}$$

where:

$$m = \cos\beta$$

$$n = \sin\beta$$

Using this approach the errors due to gage misalignment were evaluated for graphite-epoxy, using a stress level of $\sigma_x = 68.95$ MPa (10,000 psi) and the material properties previously given in Table 1. The results for the axial gage are given in Figures 8 and 9. In Figure 8 the numerical error in $\mu\text{in/in}$ between the actual axial strain ϵ_x and the

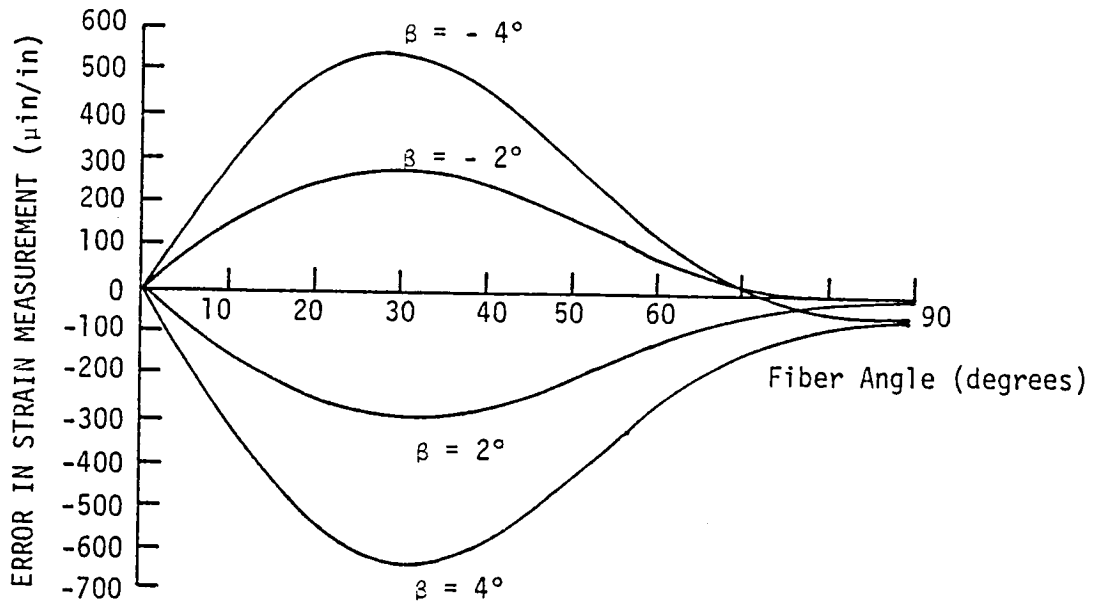

Figure 8: Error induced by misalignment of axial strain gage; graphite/epoxy

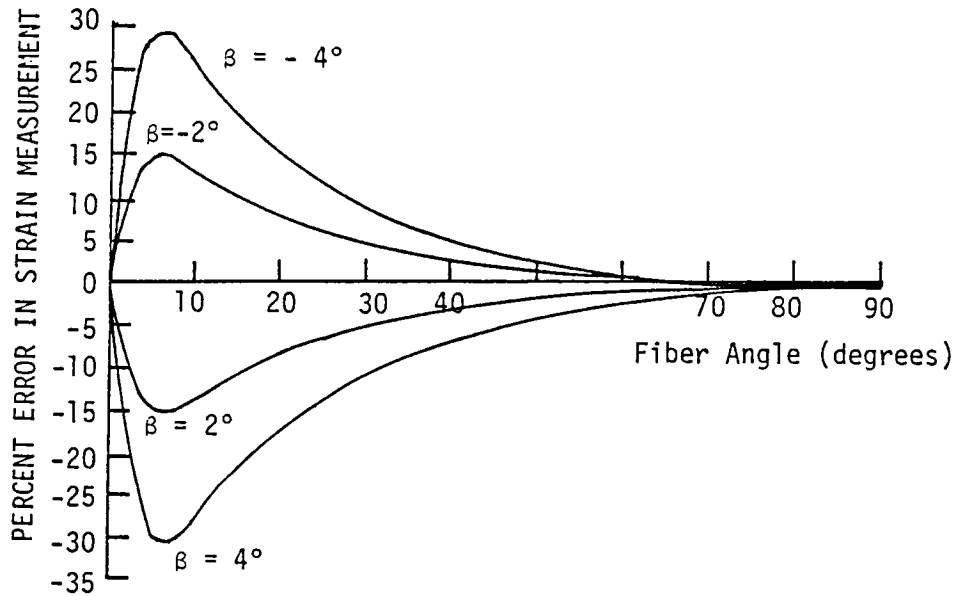

Figure 9: Percent error induced by misalignment of axial strain gage; graphite/epoxy

measured axial strain ϵ'_x is presented as a function of fiber angle θ , for misalignment errors of -4, -2, 2 and 4 degs. In Figure 9 this error is expressed as a percentage of the actual axial strain. Note that at fiber angles of 0 and 90 degs the error due to misalignment is very small, which would be expected since at these fiber angles the principal strain directions coincide with the principal stress directions. The percentage error due to misalignment is appreciable for fiber angles ranging from about 3 to 40 degs, and the error is a maximum for a fiber angle of about 8 degs.

The results for the transverse strain gage are presented in Figures 10 and 11, for the same assumed misalignment errors. Comparing these results with those for the axial gage, it is seen that while the numerical error for the transverse gage is much less than for the axial gage, the percentage error is much higher. Obviously, this is because the magnitude of the transverse strains are lower than the axial strains. Note that the sharp 'tail' in percentage error near $\theta = 90$ deg in Figure 11 is misleading, since this percentage error corresponds to a numerical error of only a few $\mu\text{in/in}$. The curves are of the same general shape for both axial and transverse cases, and the percentage error for the transverse case is again appreciable over fiber angle ranging from about 3 to 40 degs, and reaches a maximum at a fiber angle of about 8 degs.

These results are for a graphite-epoxy lamina possessing the mechanical properties listed in Table 1. Similar results would be obtained for other composite materials, or for any orthotropic material. Note that while these errors are produced by misalignment of the strain gages, similar errors would result if the fibers were slightly misaligned. Also note that the percentage error is quite high for a 10-deg

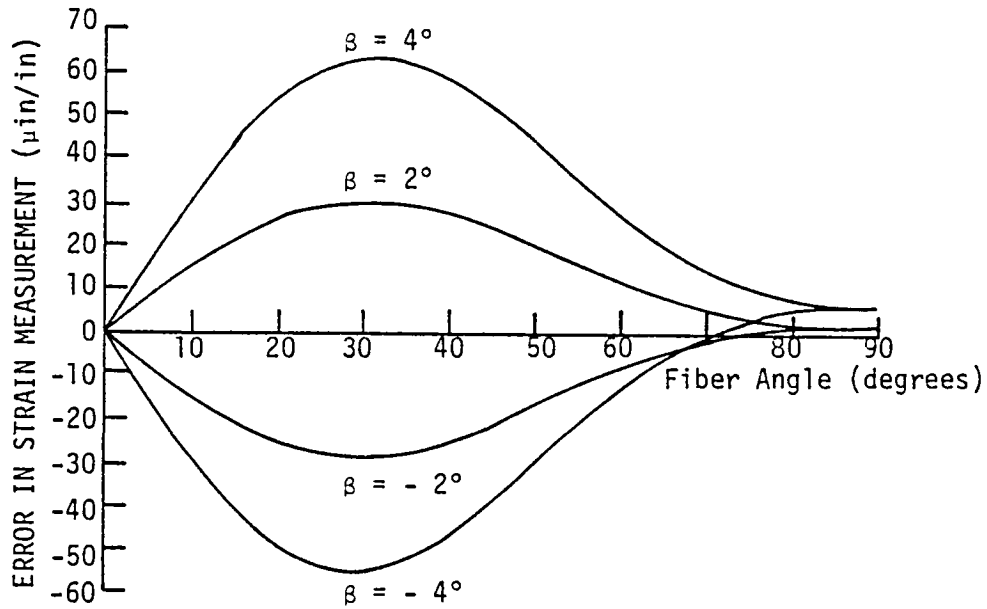

Figure 10: Error induced by misalignment of transverse strain gage; graphite/epoxy

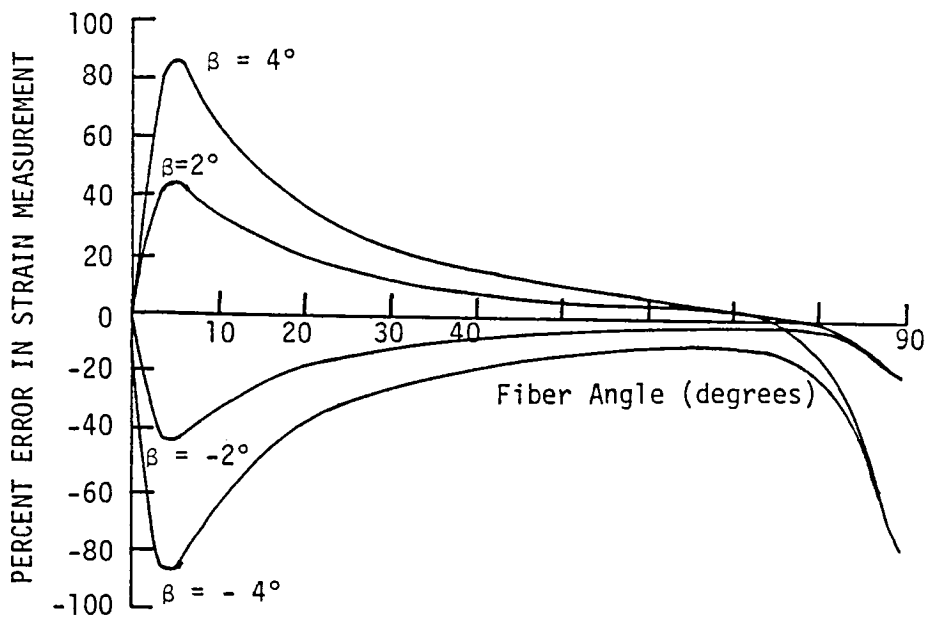

Figure 11: Percent error induced by misalignment of transverse strain gage; graphite/epoxy

off-axis specimen. This particular specimen is often used to characterize the behaviour of composites in shear [2]. Thus, both fiber and gage alignment must be kept within close tolerances when using the 10-deg off-axis specimen, as pointed out by Chamis and Sinclair.

Thermal Compensation Techniques

Of all the potential sources of error associated with the use of strain gages, the most commonly encountered and potentially most serious are those errors due to thermal effects. A change in temperature can affect strain measurement in two ways. The first is that the sensitivity of the gage to strain changes, i.e., the gage factor, changes with changing temperature. Often, the gage factor decreases with increasing temperature, although the opposite can also be true depending on the particular gage alloy being used. The percentage change in gage factor with temperature is quite small, and is normally on the order of 0.5% per 55°C (100°F) [19]. Since this change is so small, gage factor changes with temperature are often neglected. Gage factor variation with temperature is not affected by orthotropic material behaviour, and will not be further discussed in this paper.

The second effect due to temperature, and by far the most serious effect, is commonly referred to as 'apparent strain' due to temperature. Apparent strain is the result of several different factors, principally:

- A change with temperature of the electrical resistance of the strain gage.
- A mismatch between the thermal expansion coefficients of the strain gage and the test specimen.
- A change with temperature of the electrical resistance of the strain gage lead wires.

Apparent strain effects can be very large, and if not properly accounted for can completely obliterate the gage response to mechanical loading.

For purely dynamic strain measurement the need for thermal compensation is often avoided by separating the relatively low-frequency apparent strain effects from the relatively high-frequency dynamic response. This is usually accomplished by passing the gage signal through a high-pass electrical filter. The only exception is when high-frequency temperature changes occur, such as those encountered when using strain gages to measure explosively-generated shock waves, for example. For the purposes of the present discussion, it will be assumed that the temperature fluctuations being considered are of low-frequency, so that the temperature at any point in time can be considered quasi-steady state.

When static or combined static/dynamic strain measurements are made, thermal compensation is almost always required. In modern strain gage practice two methods of temperature compensation are most often used; self-temperature-compensation (S-T-C) used in conjunction with a three-leadwire system, or temperature compensation using a 'compensating' or 'dummy' strain gage. These two thermal compensation techniques as applied to composites will be discussed in the following two paragraphs. It should be noted that, at least in theory, thermal compensation is only required when the specimen temperature varies during the course of a strain measurement. However, the level of thermal stability required in order to avoid thermal effects is very difficult to obtain except under closely-controlled laboratory conditions. In practice, some form of thermal compensation is usually provided.

Self-Temperature-Compensation

A strain gage is said to be self-temperature compensated when the strain gage alloy is processed so as to minimize apparent strain effects due to temperature, when the gage is mounted to the material for which the gage was compensated. This calibration is normally applicable over a range of about -20 to 205°C (0 to 400°F). In practice, one selects the gage S-T-C number which most closely matches the thermal coefficient of expansion of the test material. For example, gages with S-T-C numbers of 06 and 13 are compensated for use with steel and aluminum, respectively.

The S-T-C method of compensation is normally used in conjunction with the three-leadwire system and the conventional Wheatstone bridge circuit [4,19]. The three-leadwire system provides compensation for changes in leadwire resistance due to temperature changes by placing equal lengths of leadwire in adjacent arms of the Wheatstone bridge. Due to the characteristics of this circuit, the leadwire effects cancel and thermal compensation for leadwire effects is achieved.

The S-T-C method is not as well suited for use with composites as with more conventional isotropic materials. Some of the difficulties encountered are:

- The thermal expansion of composites is in general a highly orthotropic material property. This implies that the appropriate gage S-T-C number would depend on both material type and desired gage orientation with respect to the principal material axis.

- The thermal properties of epoxy-matrix composites often vary from lot-to-lot and even more so from manufacturer-to-manufacturer.
- The thermal properties of epoxy-matrix composites depend to a certain extent on the previous thermal history of the composite.
- The effective thermal expansion coefficient(s) of a composite laminate depends upon laminate layup, and may be varied over a wide range of values.

These factors severely restrict the S-T-C method of compensation, when applied to composites. It is interesting to note that even if these difficulties were overcome, thermal compensation may still not be satisfactory, due to transverse sensitivity effects. That is, the gage has been calibrated for an assumed isotropic expansion or contraction, whereas the composite expands or contracts orthotropically. This results in a transverse strain being applied to the gage, which would have to be accounted for due to transverse sensitivity effects.

Thermal Compensation Using a Dummy Gage

By far the most widely used method of thermal compensation as applied to composite materials is the use of a compensating or dummy gage, in conjunction with the standard Wheatstone bridge circuit. A typical configuration is presented in Figure 12. The 'active' gage is mounted to the composite specimen and is subjected to all the mechanical loads (including thermally-induced mechanical loads) and temperature changes which occur during the course of the test. The 'dummy' gage is mounted

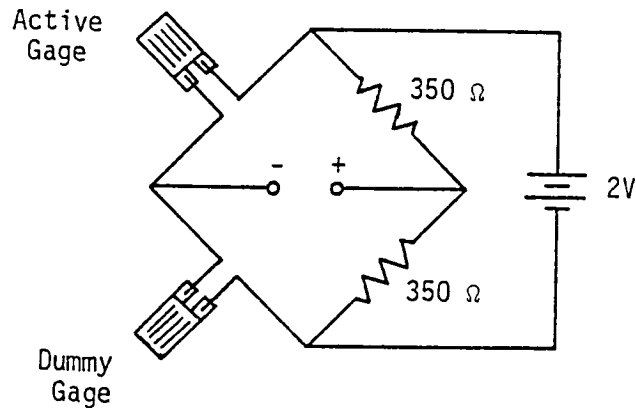

Figure 12: Typical Wheatstone Bridge circuit using a dummy gage for thermal compensation

to a sample of the composite material, and is placed as physically close to the active gage as possible. Ideally, the dummy gage experiences the same temperature changes as does the active gage, but none of the mechanical loads. Due to the characteristics of the Wheatstone bridge circuit, the apparent strain effects due to the temperature changes cancel, and the output from the active gage is due to mechanical loading only, as desired.

The orthotropic behaviour of composites impacts this form of compensation by again requiring precise gage alignment. That is, if the dummy gage is not aligned in exactly the same orientation as is the active gage, then the dummy gage does not experience the same axial or transverse strains as does the active gage. Hence, temperature compensation is not achieved.

The following numerical example will illustrate this effect. Figure 13(a) depicts strain gages mounted in axial directions on two off-axis tensile specimens. The active gage is assumed to be perfectly

aligned along the specimen axis, whereas the dummy gage has been misaligned by an angle β . A similar situation for transversely-mounted gages is shown in Figure 13(b).

Assuming a uniform temperature rise, ΔT , the perfectly aligned active gage experiences a strain field given by:

$$\begin{pmatrix} \epsilon_x \\ \epsilon_y \\ \gamma_{xy} \end{pmatrix} = \Delta T \begin{pmatrix} \alpha_x \\ \alpha_y \\ \alpha_{xy} \end{pmatrix}$$

where

$$\alpha_x = (\alpha_1 - \alpha_g)\cos^2\theta + (\alpha_2 - \alpha_g)\sin^2\theta$$

$$\alpha_y = (\alpha_1 - \alpha_g)\sin^2\theta + (\alpha_2 - \alpha_g)\cos^2\theta$$

$$\alpha_{xy} = 2(\alpha_1 - \alpha_2)\sin\theta\cos\theta$$

α_1, α_2 = coefficients of thermal expansion of composite

α_g = effective coefficient of thermal expansion of strain gage

Since the dummy gage has been misaligned, it experiences a strain field given by:

$$\begin{pmatrix} \epsilon'_x \\ \epsilon'_y \\ \gamma'_{xy} \end{pmatrix} = \Delta T \begin{pmatrix} \alpha'_x \\ \alpha'_y \\ \alpha'_{xy} \end{pmatrix}$$

where

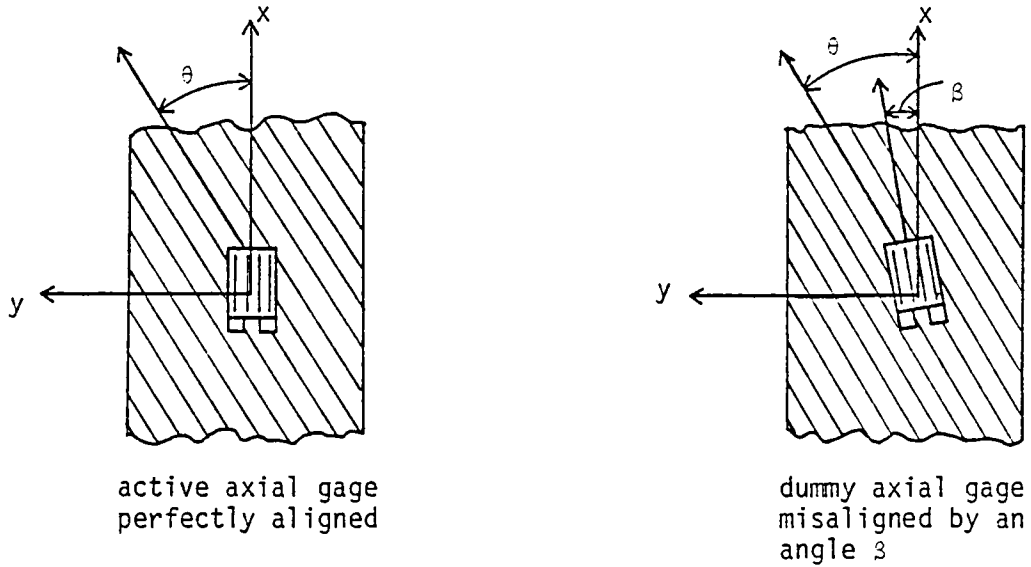

(a) Assumed strain gage orientations for axial gage case

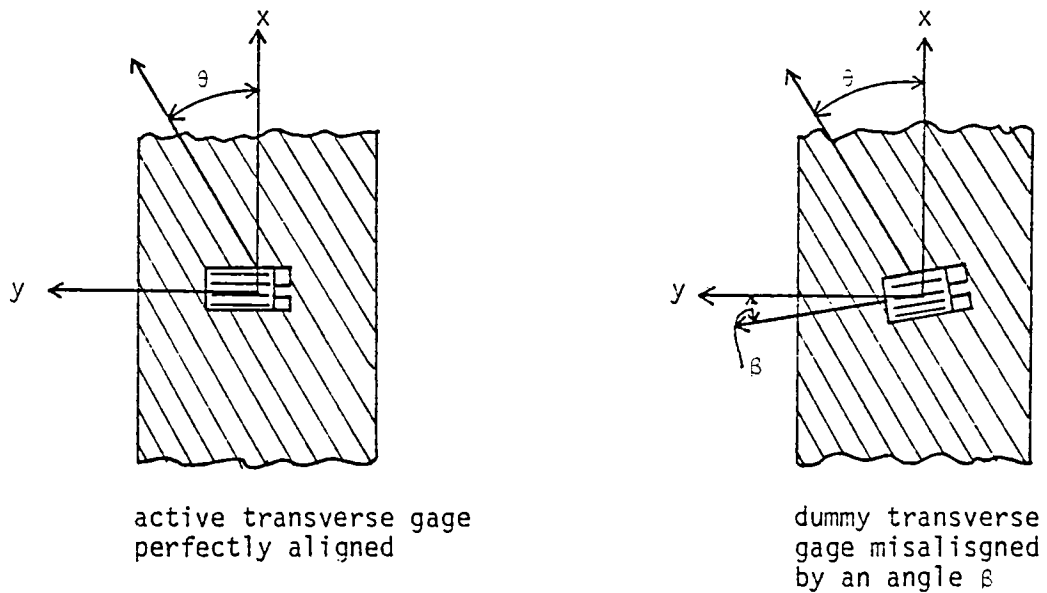

(b) Assumed strain gage orientations for transverse gage case

Figure 13: Strain gage alignments for thermal compensation.

$$\alpha'_x = (\alpha_1 - \alpha_g) \cos^2(\theta - \beta) + (\alpha_2 - \alpha_g) \sin^2(\theta - \beta)$$

$$\alpha'_y = (\alpha_1 - \alpha_g) \sin^2(\theta - \beta) + (\alpha_2 - \alpha_g) \cos^2(\theta - \beta)$$

$$\alpha'_{xy} = 2(\alpha_1 - \alpha_2) \sin(\theta - \beta) \cos(\theta - \beta)$$

To avoid undue complication, the S-T-C number of the strain gage (effectively α_g) will be assumed to be zero, and transverse sensitivity effects will be ignored. Using this approach the results presented in Figures 14 and 15 for graphite-epoxy were obtained. Thermal properties required are given in Table 1, and a temperature rise of 28°C (50°F) was assumed. Misalignment errors of -4, -2, 2, and 4 degs were considered, as before.

The results for the axial and transverse cases are seen to be very similar, and are in fact mirror images of each other. A maximum apparent strain of about 50 μ in/in occurs in both cases for a misalignment error of 4 degs, and at a fiber angle of about 45 degs. This may or may not be a significant error, depending on the strain levels and accuracy requirements involved in a given test. The point is that even under these idealized conditions temperature compensation is not achieved due to a relatively small alignment error.

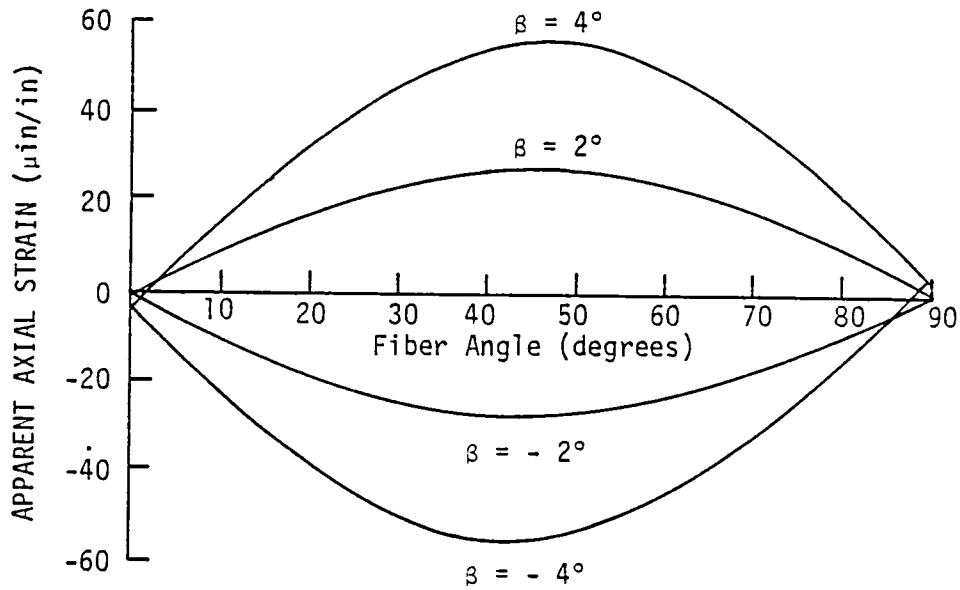

Figure 14: Apparent axial strain due to a temperature increase of 50°F ; transverse sensitivity = 0.0., graphite/epoxy

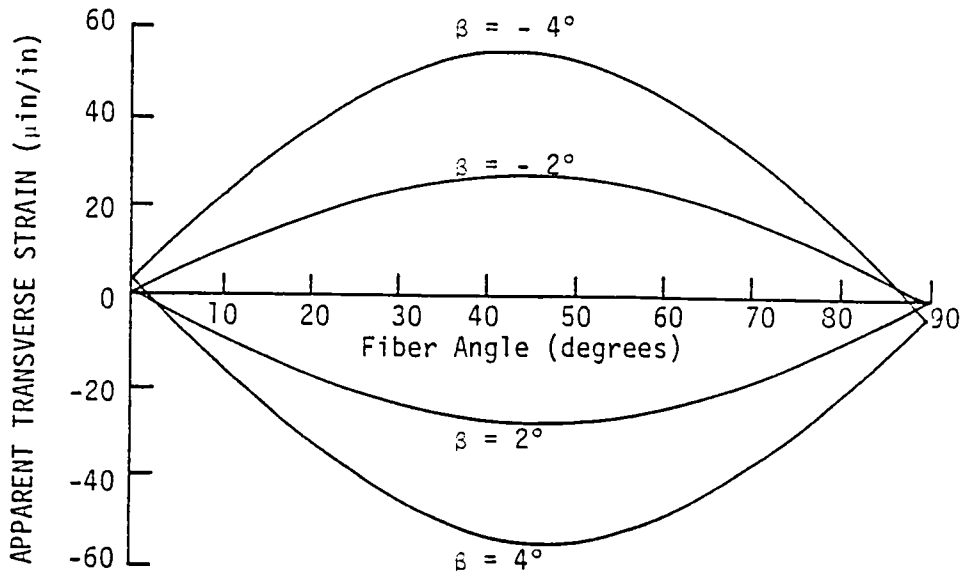

Figure 15: Apparent transverse strain due to a temperature increase of 50°F ; transverse sensitivity coefficient = 0.0; graphite/epoxy.

Discussions and Conclusions

This paper has consisted of a review of strain gage technologies as applied to orthotropic composite materials. Given the wide range of possible applications and test environments under which composites might be used, a completely general discussion including all possible aspects of this topic is beyond the scope of a single paper. Instead, an attempt has been made to include the fundamental variables which must be considered when selecting a strain gage system for use with epoxy-matrix composites. Some of the unusual problems which may be encountered due to the orthotropic behaviour of composites were also discussed. Unidirectional graphite-epoxy was used to illustrate these effects, although any composite material would exhibit a similar response. In general, the more pronounced the orthotropic behaviour, the more pronounced these effects become.

With regard to strain data acquisition and reduction, two points have been emphasized during the above presentation. These are:

- Transverse sensitivity effects should always be considered when dealing with strain data obtained for composite materials.
- Precise knowledge of the principal material directions, and precise strain gage alignment with respect to those directions is required.

The first point is important because most practical experience is based upon the behaviour of isotropic materials. As has been shown, the orthotropic nature of composites results in a propensity towards trans-

verse sensitivity errors which would not be expected based upon experience with isotropic materials. This enhancement of transverse sensitivity effects also implies a greater need for accurate measurement of the transverse sensitivity coefficient than is the case for isotropic materials.

The second point has been shown to be important both from the standpoint of error due to the misalignment itself, and from the standpoint of reduced or impaired thermal compensation capability. Gage alignment is relatively easy to assure under controlled laboratory conditions, particularly when small specimens are being used. Alignment is less easy to assure, however, when tests are being conducted in the field, or when specimen size becomes quite large. In these cases considerable care must be given to both identification of the principal material directions and to strain gage alignment.

1. Report No. NASA CR-3872		2. Government Accession No.		3. Recipient's Catalog No.	
4. Title and Subtitle Resistance Fail Strain Gage Technology as Applied to Composite Materials				5. Report Date February 1985	
				6. Performing Organization Code	
7. Author(s) M. E. Tuttle and H. F. Brinson				8. Performing Organization Report No. VPI-E-83-19	
9. Performing Organization Name and Address Department of Engineering Science and Mechanics Virginia Polytechnic Institute and State University Blacksburg, Virginia 24061				10. Work Unit No. T-4241	
				11. Contract or Grant No. NCC2-71	
12. Sponsoring Agency Name and Address National Aeronautics and Space Administration Washington, D. C. 20546				13. Type of Report and Period Covered Contractor Report	
				14. Sponsoring Agency Code 505-33-21	
15. Supplementary Notes Ames Technical Monitor: Howard G. Nelson, 244-6, NASA-Ames Research Center Moffett Field, CA 94035, (415)694-6137/FTS 448-6137					
16. Abstract <p>A general review of existing strain gage technologies as applied to orthotropic composite materials is given. The specific topics addressed are bonding procedures, transverse sensitivity effects, errors due to gage misalignment, and temperature compensation methods. The discussion is supplemented by numerical examples where appropriate.</p> <p>It is shown that the orthotropic behavior of composites can result in experimental error which would not be expected based on practical experience with isotropic materials. In certain cases, the transverse sensitivity of strain gages and/or slight gage misalignment can result in strain measurement errors.</p>					
17. Key Words (Suggested by Author(s)) Composite materials, orthotropic materials, strain gages, strain measurements			18. Distribution Statement Unclassified - Unlimited Star Category 24		
19. Security Classif. (of this report) Unclassified		20. Security Classif. (of this page) Unclassified		21. No. of Pages 45	22. Price A03

National Aeronautics and
Space Administration

Washington, D.C.
20546

Official Business

Penalty for Private Use, \$300

THIRD-CLASS BULK RATE

Postage and Fees Paid
National Aeronautics and
Space Administration
NASA-451



NASA

POSTMASTER: If Undeliverable (Section 158
Postal Manual) Do Not Return
