

General Disclaimer

One or more of the Following Statements may affect this Document

- This document has been reproduced from the best copy furnished by the organizational source. It is being released in the interest of making available as much information as possible.
- This document may contain data, which exceeds the sheet parameters. It was furnished in this condition by the organizational source and is the best copy available.
- This document may contain tone-on-tone or color graphs, charts and/or pictures, which have been reproduced in black and white.
- This document is paginated as submitted by the original source.
- Portions of this document are not fully legible due to the historical nature of some of the material. However, it is the best reproduction available from the original submission.

(NASA-CR-175552) ENGINEERING CALCULATIONS
FOR COMMUNICATIONS SATELLITE SYSTEMS
PLANNING Interim Report, 15 Jul. 1983 - 14
Jul. 1:984 (Ohio State Univ., Columbus.)
59 p HC A04/NP A01

N85-21233

Unclass
14567

CSCI 22L G3/15



The Ohio State University

ENGINEERING CALCULATIONS FOR
COMMUNICATIONS SATELLITE SYSTEMS PLANNING

C. A. Levis
C. H. Martin
C. H. Reilly
D. J. Gonsalvez
Y. Yamamura

The Ohio State University

ElectroScience Laboratory

Department of Electrical Engineering
Columbus, Ohio 43212

Interim Report 713533-5
7/15/83 - 7/14/84

Grant No. NAG 3-159

NASA Lewis Research Center
21000 Brookpark Road
Cleveland, Ohio 44135



REPORT DOCUMENTATION PAGE	1. REPORT NO.	2.	3. Recipient's Accession No.
4. Title and Subtitle ENGINEERING CALCULATIONS FOR COMMUNICATIONS SATELLITE SYSTEMS PLANNING			5. Report Date March 1985
7. Author(s) C.A. Levis, C.H. Martin, C.H. Reilly, D.J. Gonsalvez, Y. Yamamura			6.
9. Performing Organization Name and Address The Ohio State University ElectroScience Laboratory Department of Electrical Engineering Columbus, Ohio 43212			8. Performing Organization Rept. No. ESL 713533-5
12. Sponsoring Organization Name and Address NASA-Lewis Research Center 21000 Brookpark Road Cleveland, Ohio 44135			10. Project/Task/Work Unit No.
15. Supplementary Notes			11. Contract(C) or Grant(G) No. (C) (G) NAG 3-159
16. Abstract (Limit: 200 words) This interim report discusses an extended gradient search code for BSS spectrum/orbit assignment synthesis. Progress is also reported on both single-entry and full synthesis computational aids for FSS spectrum/orbit assignment purposes.			13. Type of Report & Period Covered Interim 7/15/83 - 7/14/84
17. Document Analysis			14.
a. Descriptors spectrum orbit synthesis broadcast			
b. Identifiers/Open-Ended Terms fixed service satellite regulation			
c. COSATI Field/Group			
18. Availability Statement	19. Security Class (This Report) U	21. No. of Pages 54	
	20. Security Class (This Page) U	22. Price	

TABLE OF CONTENTS

	Page
LIST OF FIGURES	ii
I. PURPOSE	1
II. BACKGROUND	1
III. IMPLEMENTATION OF THE BSS CODE FOR THE RARC-83 SCENARIO	3
IV. PROPERTIES OF THE GRADIENT-SEARCH PROCEDURE FOR SPECTRUM/ORBIT SYNTHESIS	4
A. GENERAL CONSIDERATIONS	4
B. THE OBJECTIVE FUNCTION SURFACE	6
1. Theoretical Investigation	6
2. Computer Experiments	20
V. FORMULATION OF THE FSS SYNTHESIS PROBLEM	31
A. INTRODUCTION	31
B. SIMILARITIES BETWEEN THE FSS AND BSS SYNTHESIS	31
C. DIFFERENCES BETWEEN FSS AND BSS SYNTHESIS	35
1. Importance of the Uplink	35
2. Time Division	36
3. Service Areas	39
4. Beam Shaping	48
5. The Formulation of Requirements	49
VI. CONCLUSIONS AND PLANS FOR THE NEXT ITERIM	52

LIST OF FIGURES

Figure		Page
1	Geography and requirements of the six-service-area scenario.	7
2	Sequence of service area reference frequencies.	8
3	Sequence of satellite orbit locations.	9
4	Aggregate C/I margins, relative to a 30 dB protection ratio, for the worst channel at each test point for Argentina.	10
5	Aggregate C/I margins, relative to a 30 dB protection ratio, for the worst channel at each test point for Bolivia.	11
6	Aggregate C/I margins, relative to a 30 dB protection ratio, for the worst channel at each test point for Chile.	12
7	Aggregate C/I margins, relative to a 30 dB protection ratio, for the worst channel at each test point for Paraguay.	13
8	Aggregate C/I margins, relative to a 30 dB protection ratio, for the worst channel at each test point for Peru.	14
9	Aggregate C/I margins, relative to a 30 dB protection ratio, for the best channel at each test point for Uruguay.	15
10	Feasible region of the reduced BSS synthesis problem.	18
11	Objective function surface cross-section for the reduced BSS synthesis problem.	19
12	Worst C/I ratio for each service area vs. iteration number. Run 1.	21
13	Worst C/I ratio for each service area vs. iteration number. Run 2.	23
14	Satellite orbit locations for each service area vs. iteration number. Run 2.	23

Figure		Page
15	Reference frequency assignments vs. iteration number. Run 2.	25
16	Worst C/I ratio for each service area vs. iteration number. Run 3.	27
17	Satellite orbit locations for each service area vs. iteration number. Run 3.	28
18	Reference frequency assignments vs. iteration number. Run 3.	29
19	Schematic representation of the spatial relations between satellites and Earth stations.	33
20	Minimum orbital spacing for Earth-coverage satellite assignments, based only on down-link considerations.	41
21	Geometry of Earth-stations and satellites, defining the angle variables.	44
22	Allowable satellite spacings as function of minimum Earth station separation, given in terms of off-axis angles.	46
23	Minimum satellite spacing when Earth stations are separated a minimum longitude difference ϕ by service area assignment.	47
24	Proposed requirements table.	50

I. PURPOSE

The purpose of this grant is to develop methods and procedures, including computer codes, for performing engineering calculations which will be useful to the United States delegations to international administrative conferences regarding satellite communications. During the interim 15 July 1983 to 14 July 1984, by far the greater part of the effort has been devoted toward the Fixed Satellite Service (FSS) which will be a topic of the World Administrative Radio Conferences in 1985 and 1988 (WARC-85, WARC-88). Some attention was also directed toward optimizing the implementation of decisions reached at the 1983 Regional Administrative Radio Conference (RARC-83) which dealt with the Broadcasting Satellite Service (BSS).

II. BACKGROUND

The interim prior to this one was devoted primarily to writing a computer code for optimizing the orbital locations and frequency assignments for BSS satellites [1]. Such a program is called a synthesis program. Substantial work on BSS synthesis was already under way on the part of other administrations when we entered the field, and the lead time for a program which might be useful at RARC-83 was short. The decision was made to base the program on a constrained gradient-search procedure. This decision was based on four considerations: 1) the general procedures for implementing a constrained gradient search are well-known and readily available,

2) an existing analysis code, called Spectrum/Orbit Utilization Program (SOUP) [2], was helpful in defining the objective function for the gradient search, 3) the method would be complementary to, instead of competitive with, the approaches taken by the other administrations, and 4) the method should be useful in optimizing further ("fine-tuning") whatever plan might be developed without it.

Our BSS synthesis code was not completed in time to be proposed for adoption for RARC-83. An attempt was made to make it available on an informal basis to the U. S. delegation, but this foundered on the difficulty of linking the computers on which it was implemented with those in use at the Conference, and also because the formats for the required inputs were changed shortly before and during the Conference. The program was tested by means of a substantially reduced initial scenario generated at our facility by eliminating from the complete set of administrations and test points all those for which information in the various input files available to us at the time was either incomplete or conflicting. Preliminary tests had been performed on an even smaller model consisting of six administrations and 40 test points in South America [1]. These results all looked very encouraging; but it should be recalled that gradient-search procedures are guaranteed only to lead to local optima, not global ones, unless the objective function is convex, which is not the case here. Thus there remained still the question of just "how good" the gradient-search method is for the task at hand, i.e., how severely the solution depends on the initial scenario and whether a method for generating good initial scenarios can be devised.

These questions are doubly important because the gradient-search procedure can also be proposed reasonably for the FSS problem; indeed the BSS and FSS problems have strong similarities, as explained below. Much of the work reported below to resolve the "goodness" of the gradient-search procedure for the BSS problem would not have been undertaken if it did not apply directly to a half-link of the FSS problem as well.

III. IMPLEMENTATION OF THE BSS CODE FOR THE RARC-83 SCENARIO

Three problems were encountered at the outset in the implementation of the gradient-search synthesis code to the scenario produced as the output of RARC-83. First, the gradient-search code had been set up to handle block frequency assignments, i.e., the assignment of complete frequency blocks to individual administrations. The Conference kept this concept in the main but modified it to include channel family patterns. In these, some channels of a block might be shared between several administrations, while others would be assigned to individual administrations. The code had to be revised to allow for these channel family patterns. Secondly, the RARC-83 scenario required fixed, predetermined frequencies to be assigned to the starting points for the channel families. The gradient-search procedure is a continuous process which does not necessarily lead to these preassigned discrete values. Two approaches to solve this problem are to round the frequencies, each to the nearest preassigned frequency, either at the end of the process (which may then have to be repeated) or at each iteration. It is not

clear what effect these procedures will have on the convergence of the process. Also, it is not clear whether the use of preassigned, fixed starting frequencies has any real practical or economic value, or whether it was based primarily on custom. From a spectrum/orbit utilization standpoint, there could be substantial advantages in allowing arbitrary channel family starting frequencies. This question has not been resolved.

Finally some quite mundane, but nevertheless very time-consuming, problems arose from the difficulty of obtaining definitive and compatible data sets. Three input data sets are required: the requirements file, the minimum-ellipse file, and the actual full scenario decided by the Conference, which would serve as an initial scenario for our attempts at further improvements. Inconsistencies between the three sets, as furnished to us, were very troublesome.

Due to these difficulties we have not been able to attempt an improvement in the final RARC-83 scenario with the gradient-search code, but we look forward to doing so in the near future. At that time we plan to issue a technical report documenting the program fully and to report on it in the literature as well.

IV. PROPERTIES OF THE GRADIENT-SEARCH PROCEDURE FOR SPECTRUM/ORBIT SYNTHESIS

A. GENERAL CONSIDERATIONS

As discussed above, the time scale on the BSS synthesis problem forced a rather pragmatic approach and precluded a general investigation

of the properties of the extended gradient-search method with respect to spectrum/orbit synthesis and, in particular, the generation of good initial scenarios, which would lead to global or near-global optimal solutions. Since WARC-85 will be concerned mostly with planning the procedures for WARC-88, rather than with the implementation of any detailed plan, we have more lead-time with respect to the FSS synthesis. Of course gradient-search procedures have been used successfully in many applications where optimal solutions were not assured; nevertheless, it seemed prudent to gain a better understanding of the objective-function surface in order to be able to understand better the likelihood of a good solution and how that depends on the initial conditions. This would give us the option to make modifications in our approach if necessary: perhaps to add an integer-programming code to help select initial conditions for the gradient search, or to switch to integer-programming altogether if this seems indicated. While the intended application is the FSS problem, the objective functions for the FSS and BSS synthesis problems are so closely related that the BSS code is a useful test bed for the FSS application. This is discussed in more detail below.

A first step in investigating the behavior of the gradient-search process was to find convenient ways of displaying the results of a sequence of solutions obtained by iteration, in order to enhance the convenience of interaction between the code and the analyst. A graphical display was, therefore, developed as an adjunct to the print-outs employed previously. This display is illustrated in the

first eight figures. Figure 1 illustrates the geography and the channel requirements for the previously developed six-administration experimental scenario. The dots at the administration boundaries show the test points for each service area. Figure 2 shows the sequence of reference frequencies as the iterations progress; Figure 3 does the same for the satellite orbit locations. Finally, Figures 4 to 9 display the C/I margins at each test point for each service area during the first few iterations. In Figures 4 to 8 the margin for the worst channel at each test point is displayed; in Figure 9, it is the best channel that it displayed. Figure 9 shows that the exponential objective function has the desired property of improving C/I at the bad test points even at the expense of worsening it at other test points, if required.

B. THE OBJECTIVE FUNCTION SURFACE

1. Theoretical Investigation

Very little is really known about the objective function surface for a half-link, which occurs both in the BSS and the FSS synthesis problems. An appreciation for the properties of this surface could result in our being able to assess objectively the quality of a particular solution and/or to recognize a solution methodology more appropriate than the extended gradient search. We have elected to examine the objective function surface from both the analytical and empirical points of view.

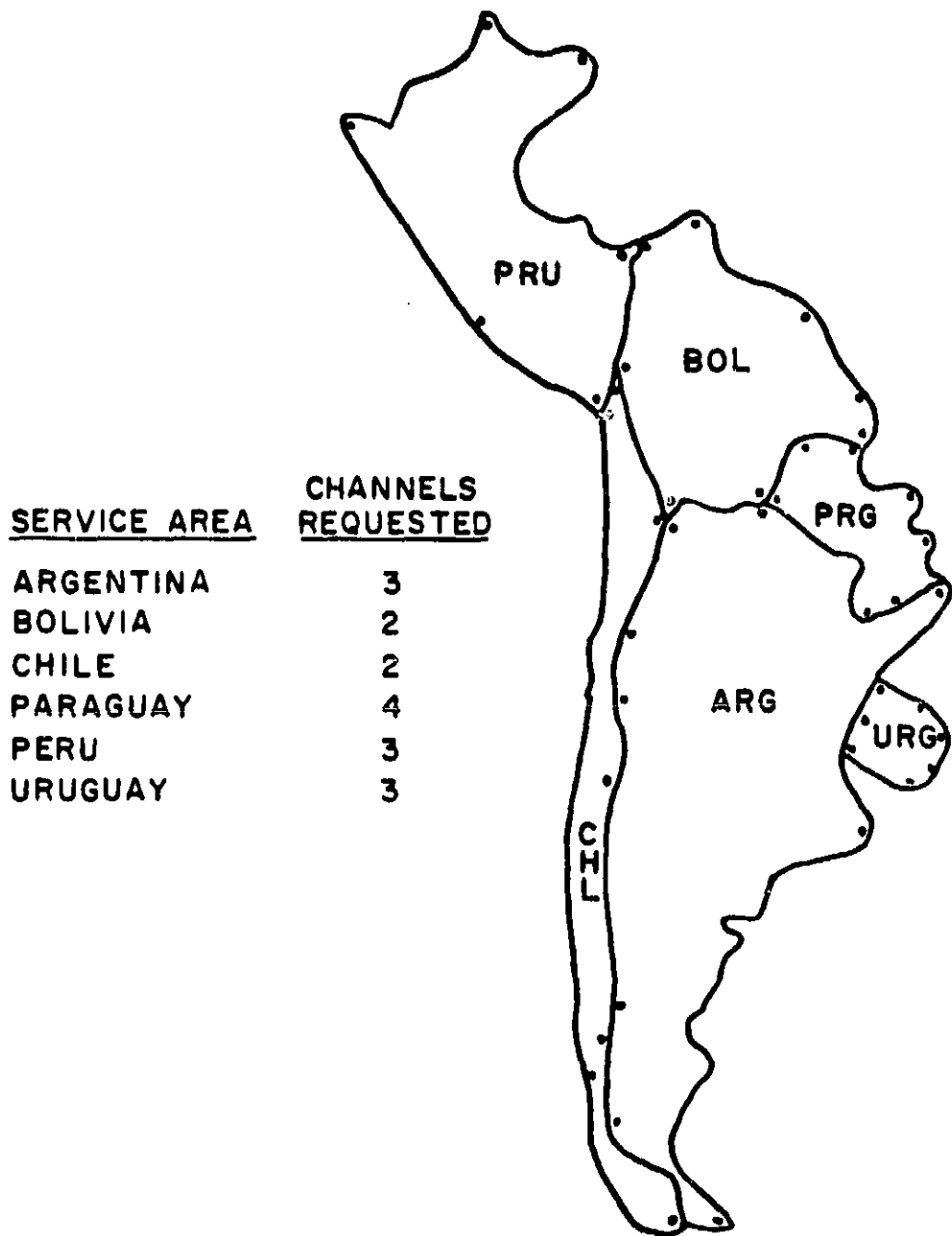

Figure 1. Geography and requirements of the six-service-area scenario. Dots indicate test points.

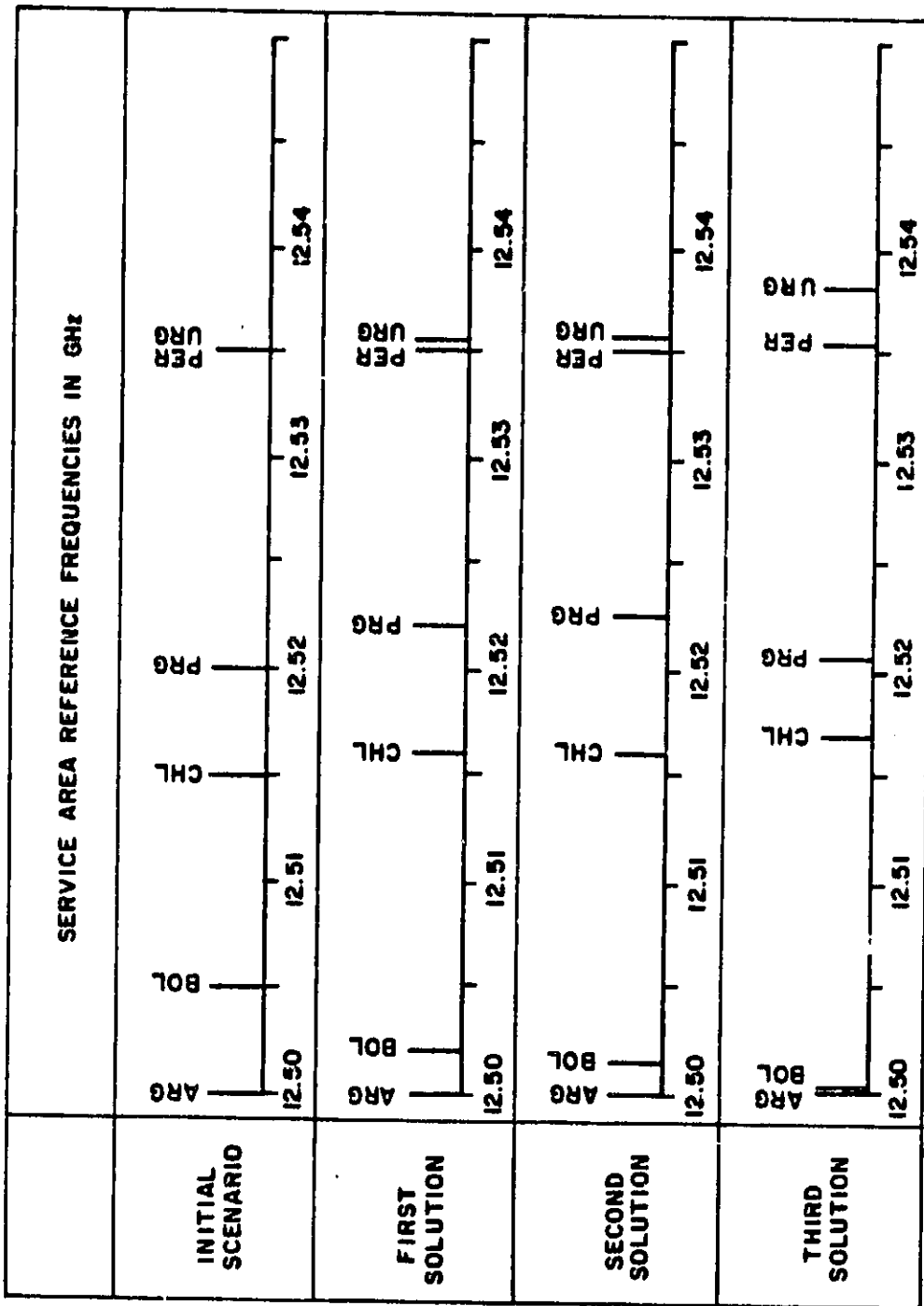

Figure 2. Sequence of service area reference frequencies.

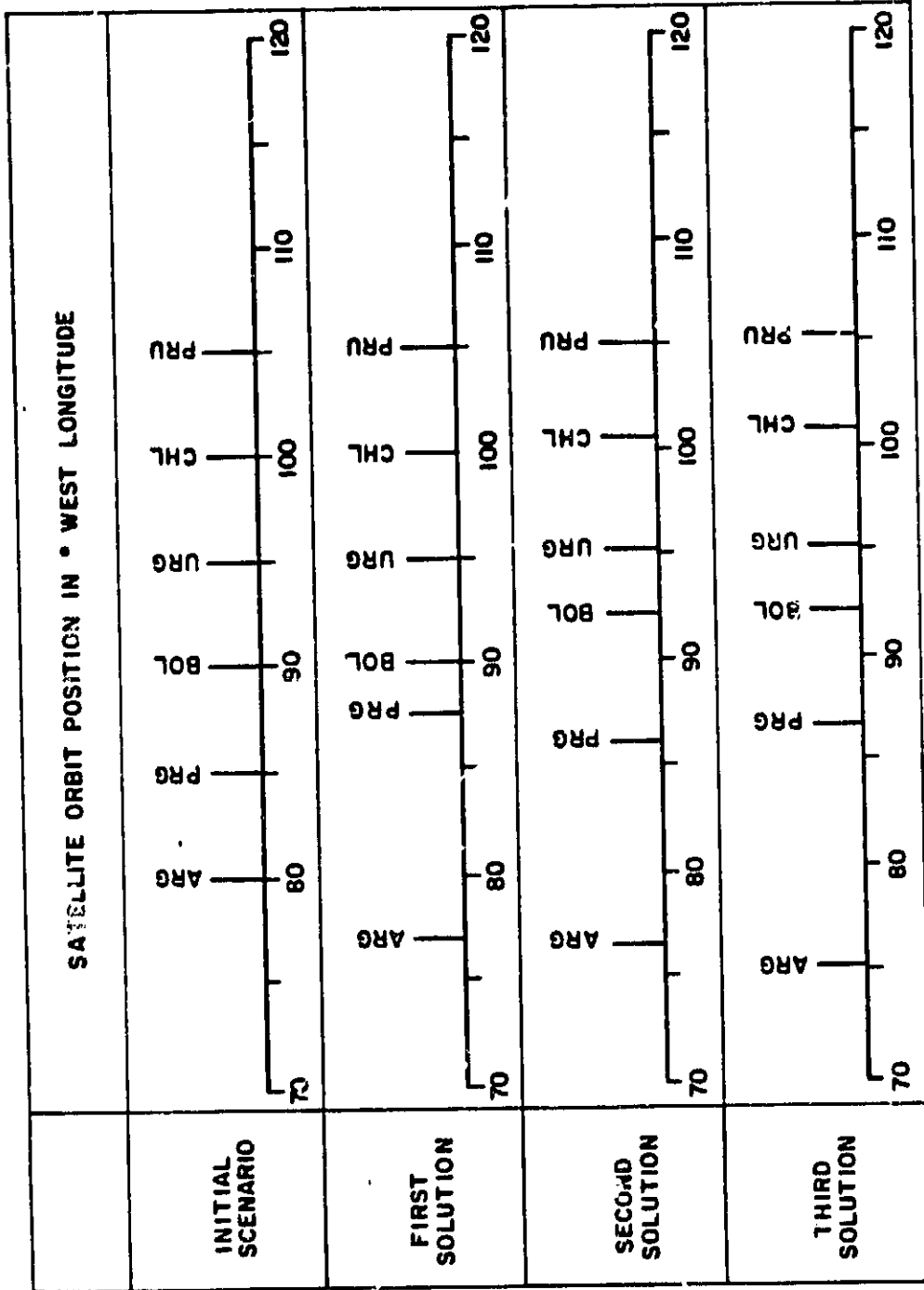

Figure 3. Sequence of satellite orbit locations.

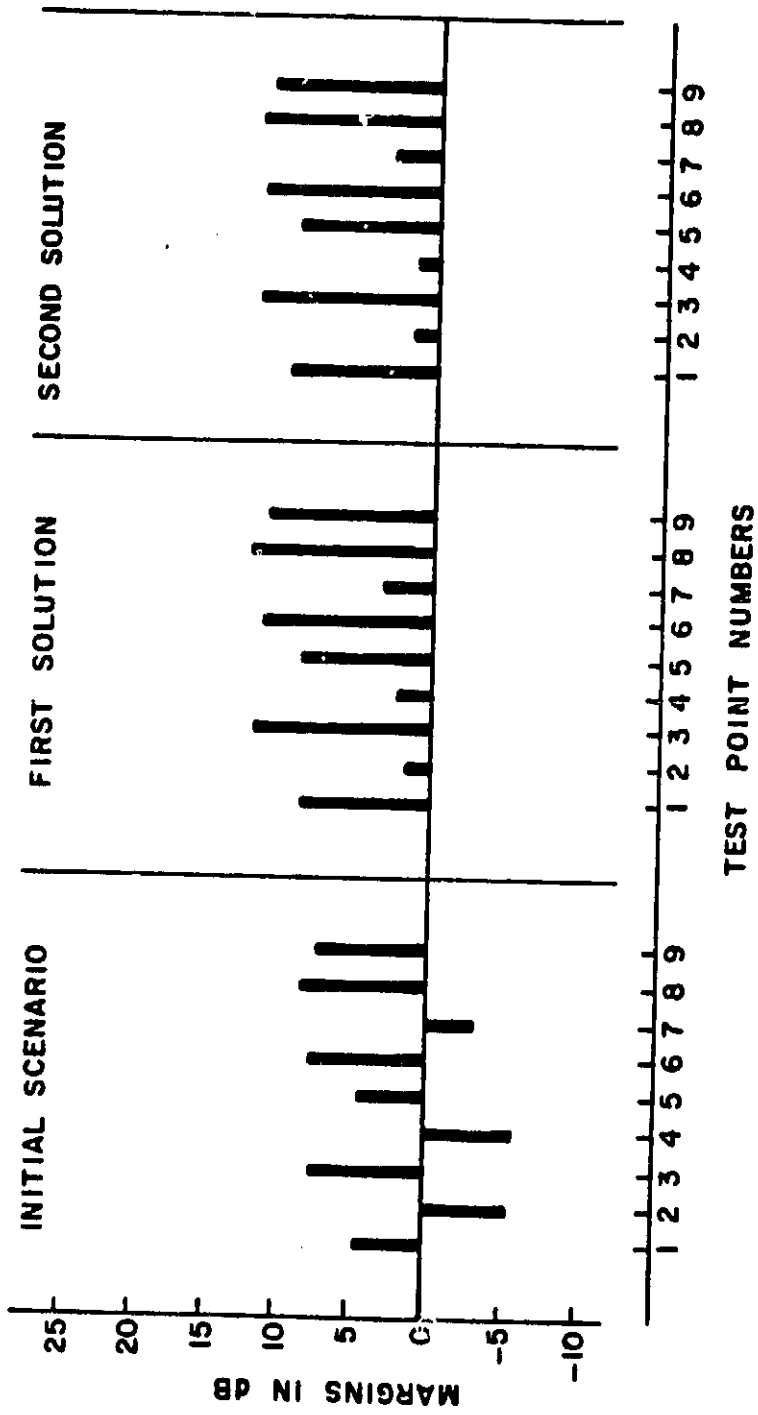

Figure 4. Aggregate C/I margins, relative to a 30 dB protection ratio, for the worst channel at each test point for Argentina.

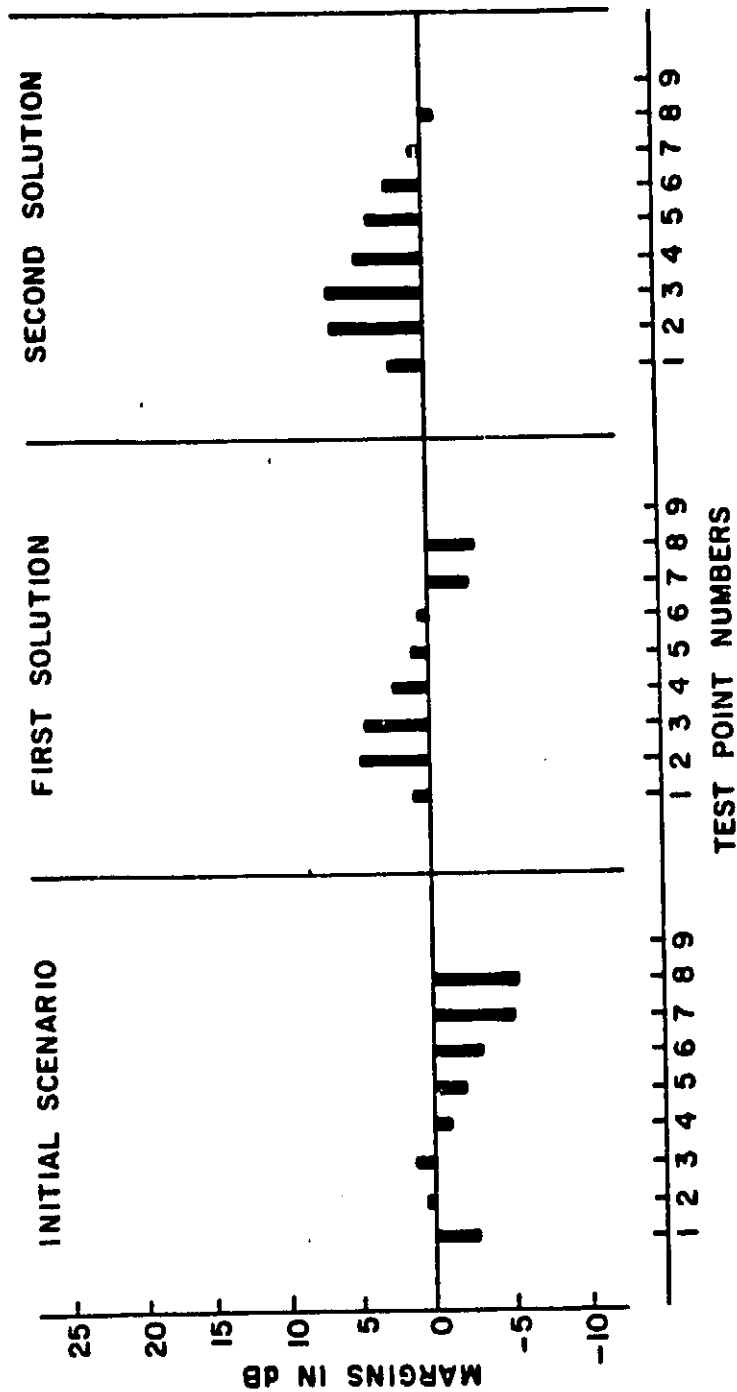

Figure 5. Aggregate C/I margins, relative to a 30 dB protection ratio, for the worst channel at each test point for Bolivia.

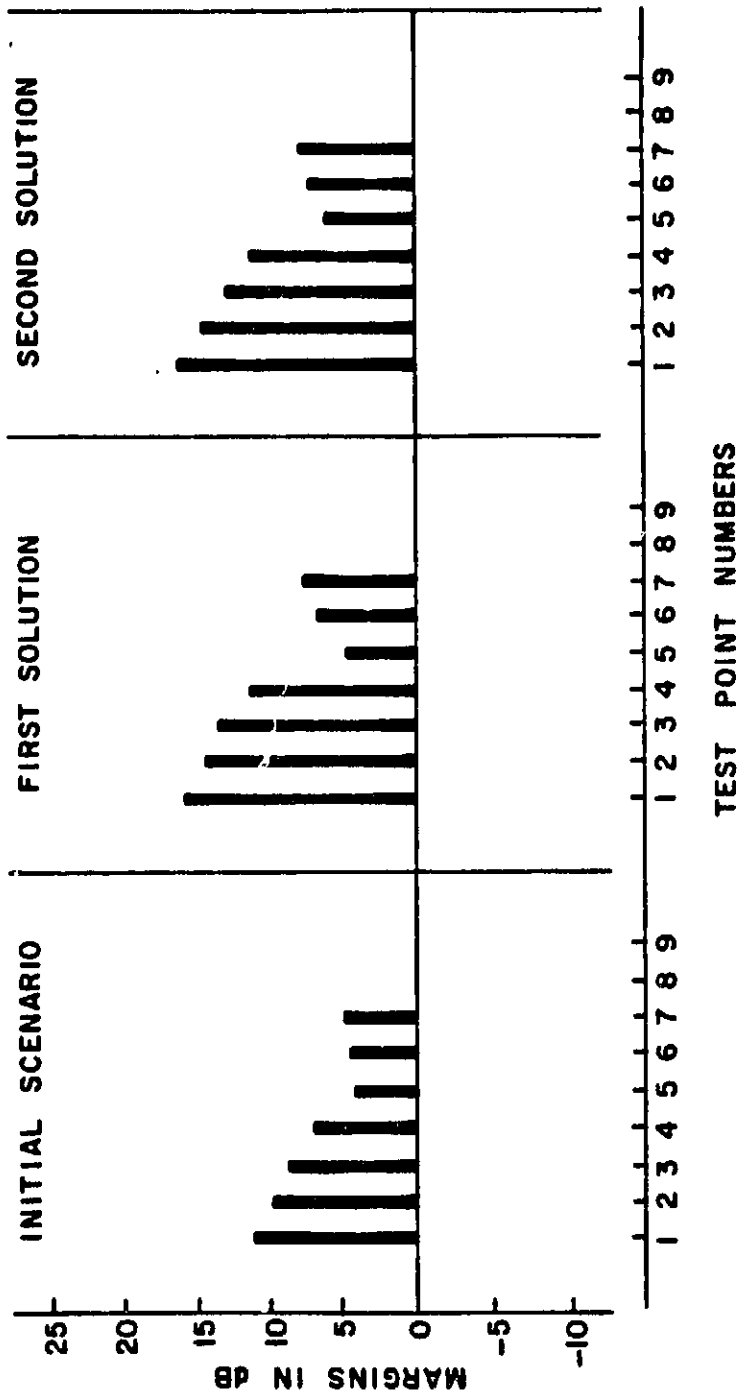

Figure 6. Aggregate C/I margins, relative to a 30 dB protection ratio, for the worst channel at each test point for Chile.

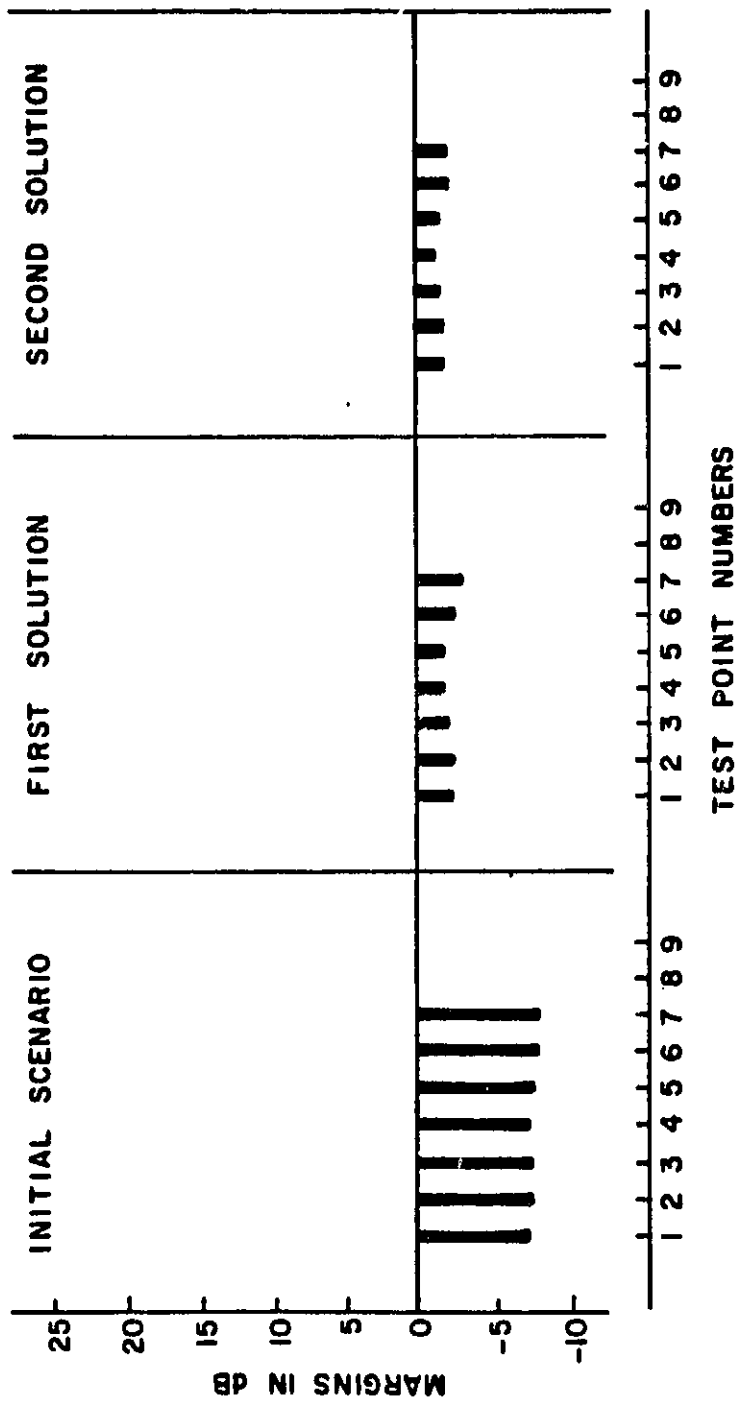

Figure 7. Aggregate C/I margins, relative to a 30 dB protection ratio, for the worst channel at each test point for Paraguay.

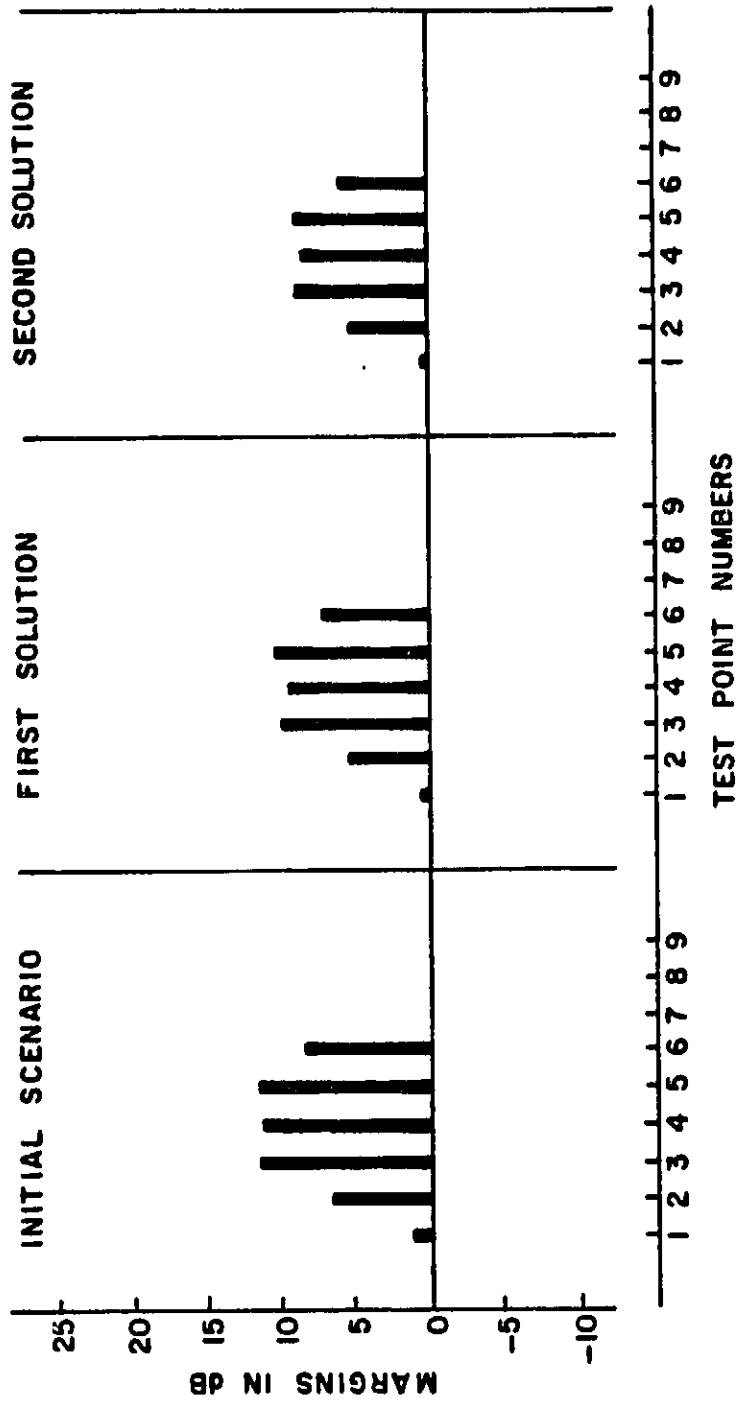

Figure 8. Aggregate C/I margins, relative to a 30 dB protection ratio, for the worst channel at each test point for Peru.

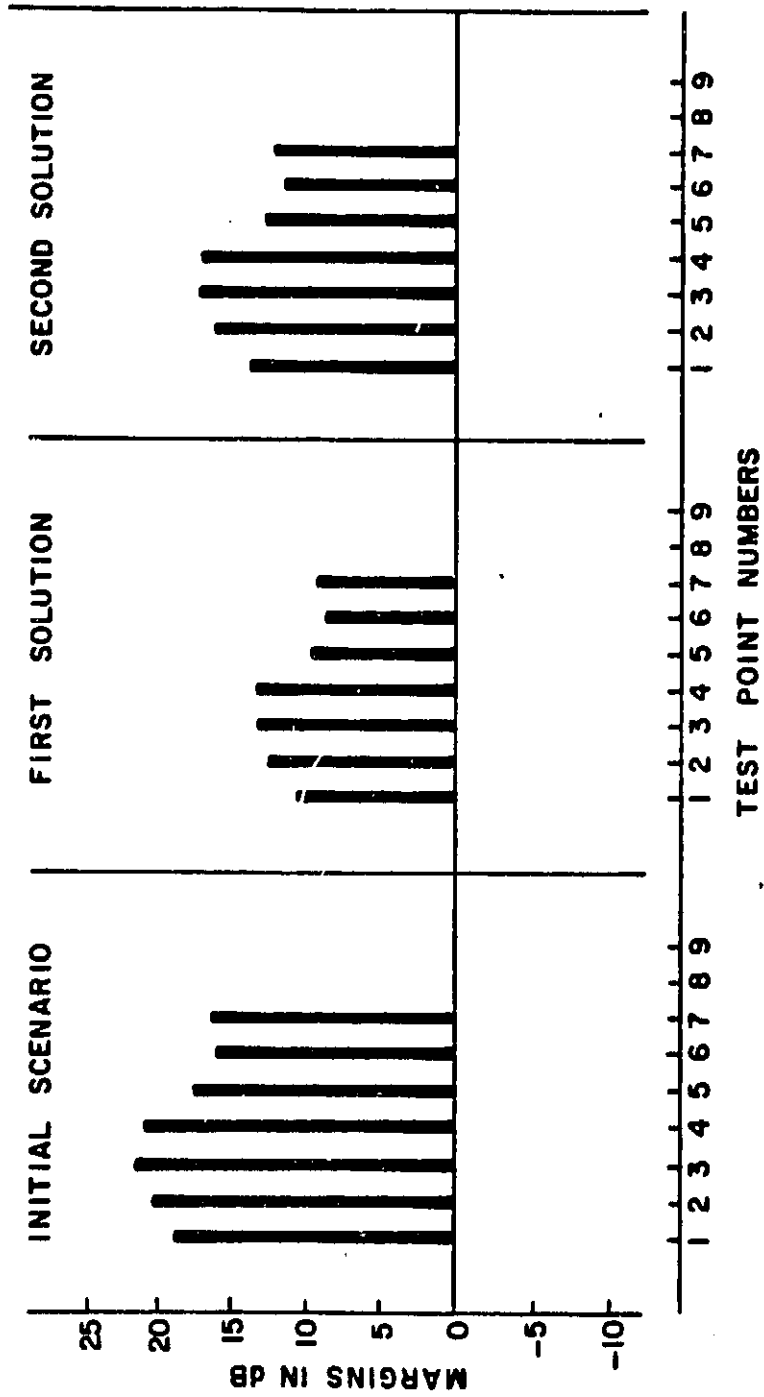

Figure 9. Aggregate C/I margins, relative to a 30 dB protection ratio, for the best channel at each test point for Uruguay.

In order to begin the analytical investigation, a greatly simplified version of the synthesis problem was needed. The following simplifying assumptions were made:

- 1) two satellites,
- 2) two service areas, each served by one of the two satellites,
- 3) one test point in each service area,
- 4) one channel requested for each service area, and
- 5) the orbital positions of the two satellites are fixed.

Under these assumptions, the down-link synthesis problem reduces to the determination of frequency assignments for the two satellites:

$$\text{Minimize } C_1 \exp(F_{21}^f - 20 \log_{10}(F_2)) + C_2 \exp(F_{12}^f - 20 \log_{10}(F_1)) \quad (1)$$

$$\text{subject to } \underline{F}_1 < F_1 < \bar{F}_1, \quad (2)$$

$$\text{and } \underline{F}_2 < F_2 < \bar{F}_2, \quad (3)$$

$$\text{where } C_j = [\exp(P_j)]^{-1}, \quad k=1,2, \quad (4)$$

P_{jj} is the power transmitted by satellite j , on its assigned channel, j .

F_{ij}^f is the frequency discrimination between channels

i and j , and F_j is the frequency assigned to channel j .

With the assumptions made here, the solution of the reduced down-link synthesis problem is straightforward and the result is rather obvious: the separation of the frequencies assigned to the two satellites should be as large as possible. More important than this solution is the fact that the objective function surface for the reduced problem can be plotted.

We will assume that the decision variables for the frequencies both have the same lower and upper bounds, i.e., $F_1 = F_2 = F$ and $\bar{F}_1 = \bar{F}_2 = \bar{F}$. The frequency discrimination function effectively partitions the feasible region into five subregions, see Figure 10. In the subregion where the two satellites' frequencies are most nearly equal, the objective function value would be largest. As the frequencies become more and more distinct, i.e., as we move away from the $F_1 = F_2$ line in a direction perpendicular to this line, the objective function value will decrease steadily. A cross-sectional view of the objective function surface, perpendicular to the $F_1 = F_2$ line, is shown in Figure 11. This view is the cross-sectional profile one would see when looking from the origin down the $F_1 = F_2$ line.

It is clear from this cross-sectional view that the objective function for the reduced BSS synthesis problem is neither convex nor concave. The absence of such exploitable functional properties can make the solution of even small nonlinear programming problems difficult. The relaxation of the simplifying assumptions made, e.g., treating orbital positions as variables, can only make guaranteeing optimality for the BSS synthesis by gradient-search methods more difficult from a theoretical point of view.

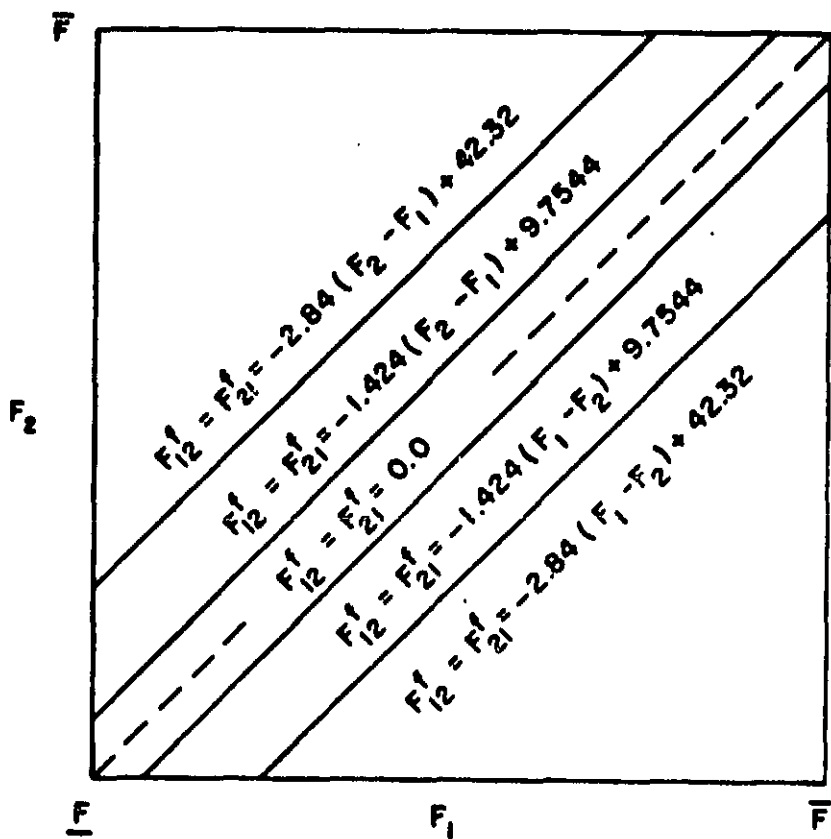

Figure 10. Feasible region of the reduced BSS synthesis problem. The solid lines separate subregions of the feasible region wherein the indicated expressions for the filter functions apply. The dashed line represents points where $F_1 = F_2$.

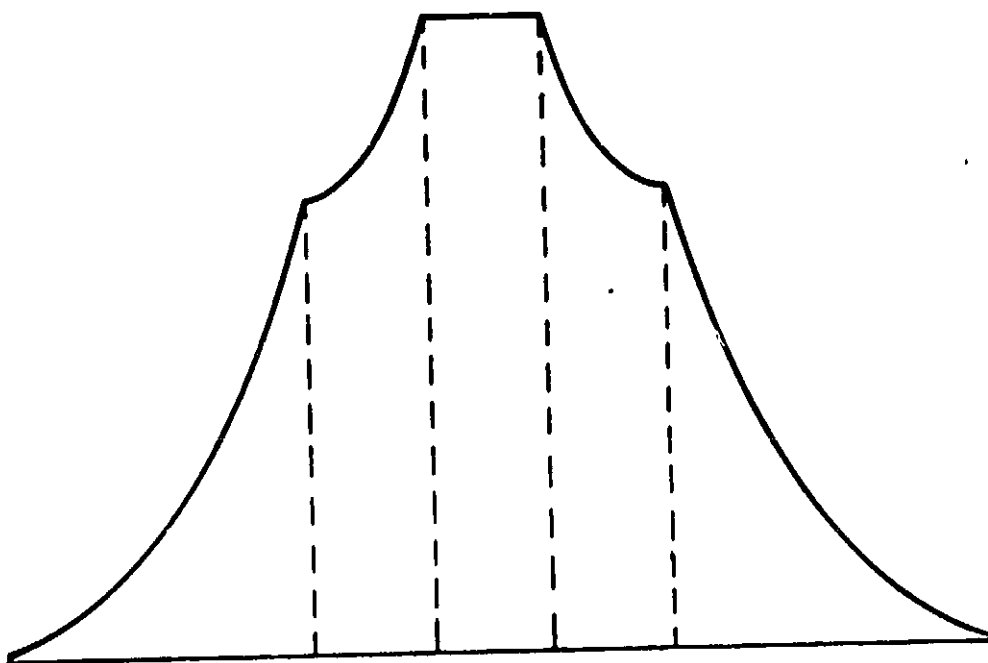

Figure 11. Objective function surface cross-section for the reduced BSS synthesis problem. The dashed lines separate the subregions indicated in Figure 10.

It is our intention to continue our analysis of the synthesis problem. Future theoretical investigations will be concerned with the properties of the objective function surfaces of more elaborate versions of the BSS synthesis problem and with the performance of the extended gradient search procedure.

2. Computer Experiments

The six-administration South American model was exercised under seven different conditions (scenarios) by varying the initial scenario and the orbital location and frequency bounds. By exercising the model in this manner, we are able to begin to see the effect which an initial scenario has on the final solution obtained, as well as the effects of limiting the use of the orbital arc and the available bandwidth.

All of the computer runs were terminated after nine iterations of the extended gradient search procedure. The solutions obtained at intermediate iterations, not only the final solutions, were examined. We shall present the details of the results observed with three of the seven scenarios as well as some general observations based on all of the runs made.

The first scenario considered here is the same as that which appeared in our last interim report [1]. Figure 12 shows the worst aggregate C/I ratio for each administration for the initial scenario (iteration 0) and some of the improved solutions (iterations 1 through 9). The worst aggregate C/I ratio for the initial solution was about 22 dB. After four iterations, the worst C/I ratio for any test

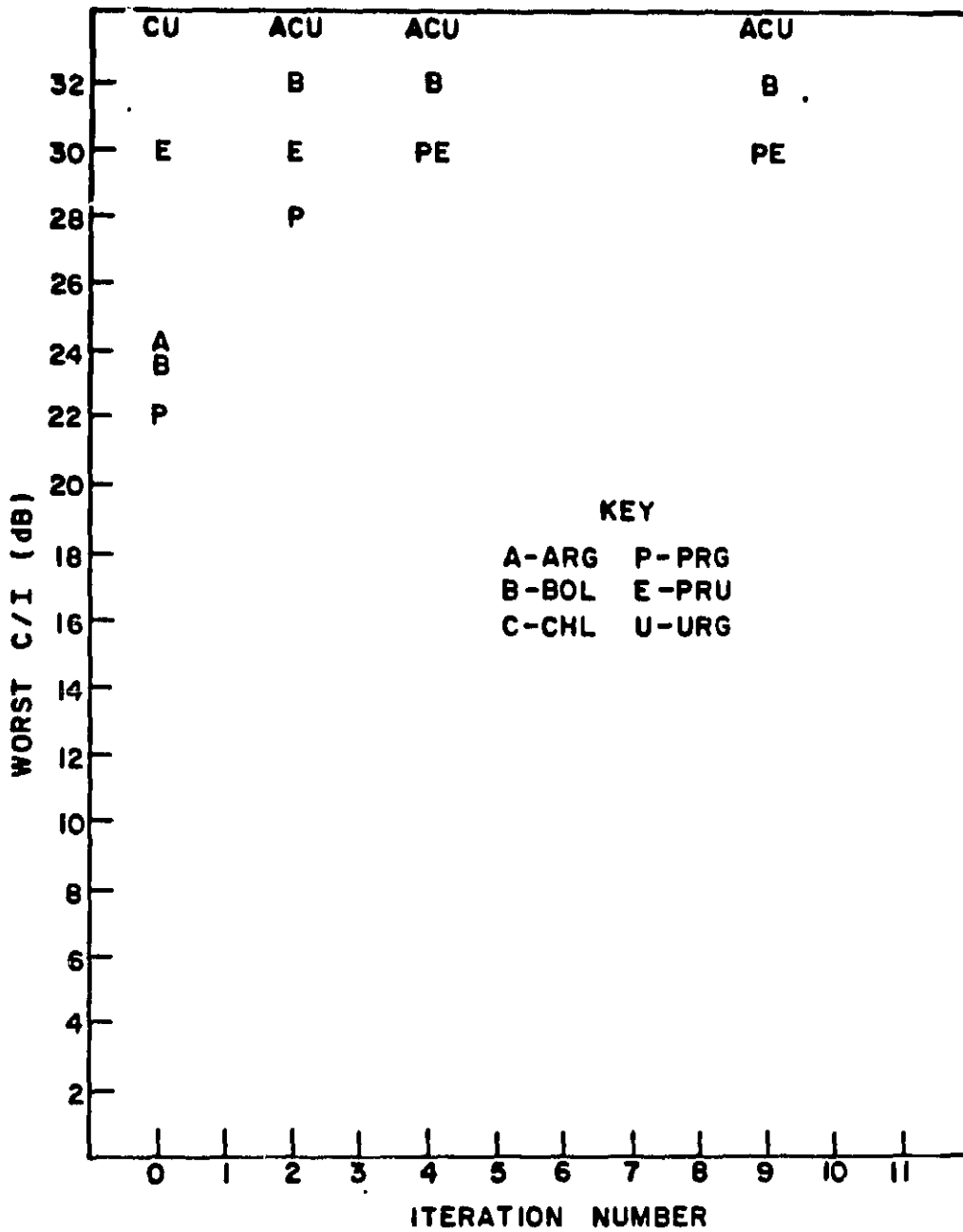

Figure 12. Worst C/I ratio for each service area vs. iteration number. Run 1. Iteration 0 represents the initial scenario, which is the same as shown in Figures 2 and 3.

point was about 30 dB. There was no appreciable improvement in the C/I ratios over the last five iterations.

The results for this first scenario indicate that there is steady improvement in the C/I ratios from the start. A reasonably good solution is obtained, at least in this case, after just a few iterations. No marked change occurs after this good solution is found. Had we executed more iterations of the gradient search procedure, it is possible that an improved solution could have been found. The fact that practically no change occurs between the fourth and ninth iterations does not necessarily imply that the gradient search should have been terminated earlier.

A second scenario with a "horrendous" starting scenario was considered also. All six satellites were collocated and were assigned the same frequency. Figures 13, 14, and 15 provide a graphical representation of the solutions obtained with this "poor" starting scenario. These figures indicate the satellite orbital location, the frequency assignment, as well as the worst aggregate C/I ratio for each administration.

Again, it takes but a few iterations to obtain a good solution. Both the orbital locations and frequency assignments are spread out immediately. It is interesting to note that the solution obtained after nine iterations, starting with a "poor" solution, is better than the solution obtained with a more "reasonable" starting solution (Run 1). In other words, the relative acceptability of a scenario as a final solution is not necessarily correlated with its quality as a starting scenario.

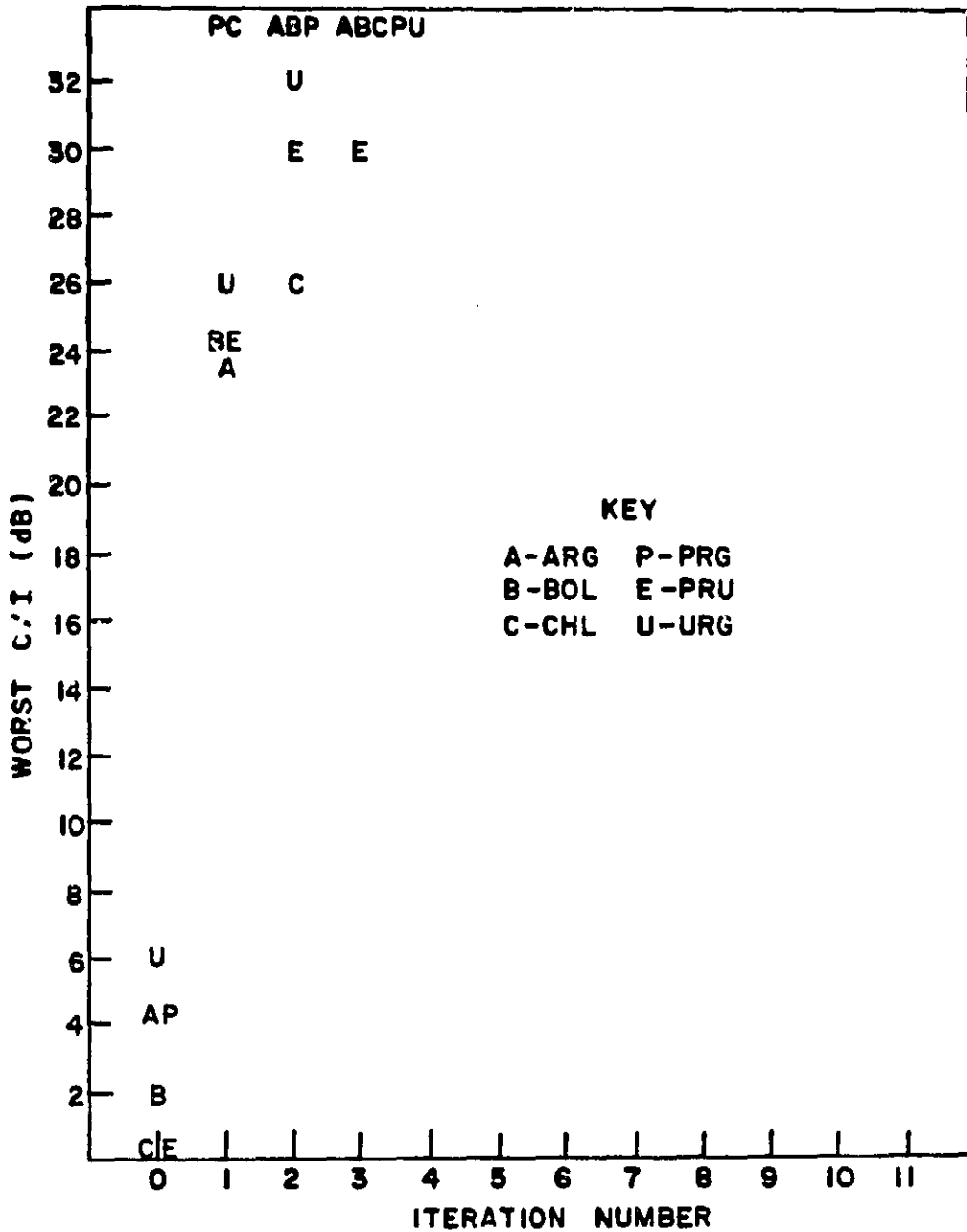

Figure 13. Worst C/I ratio for each service area vs. iteration number. Run 2.
 Initial scenario: all satellites and reference frequencies collocated at 95° W and 12.55 GHz, respectively.

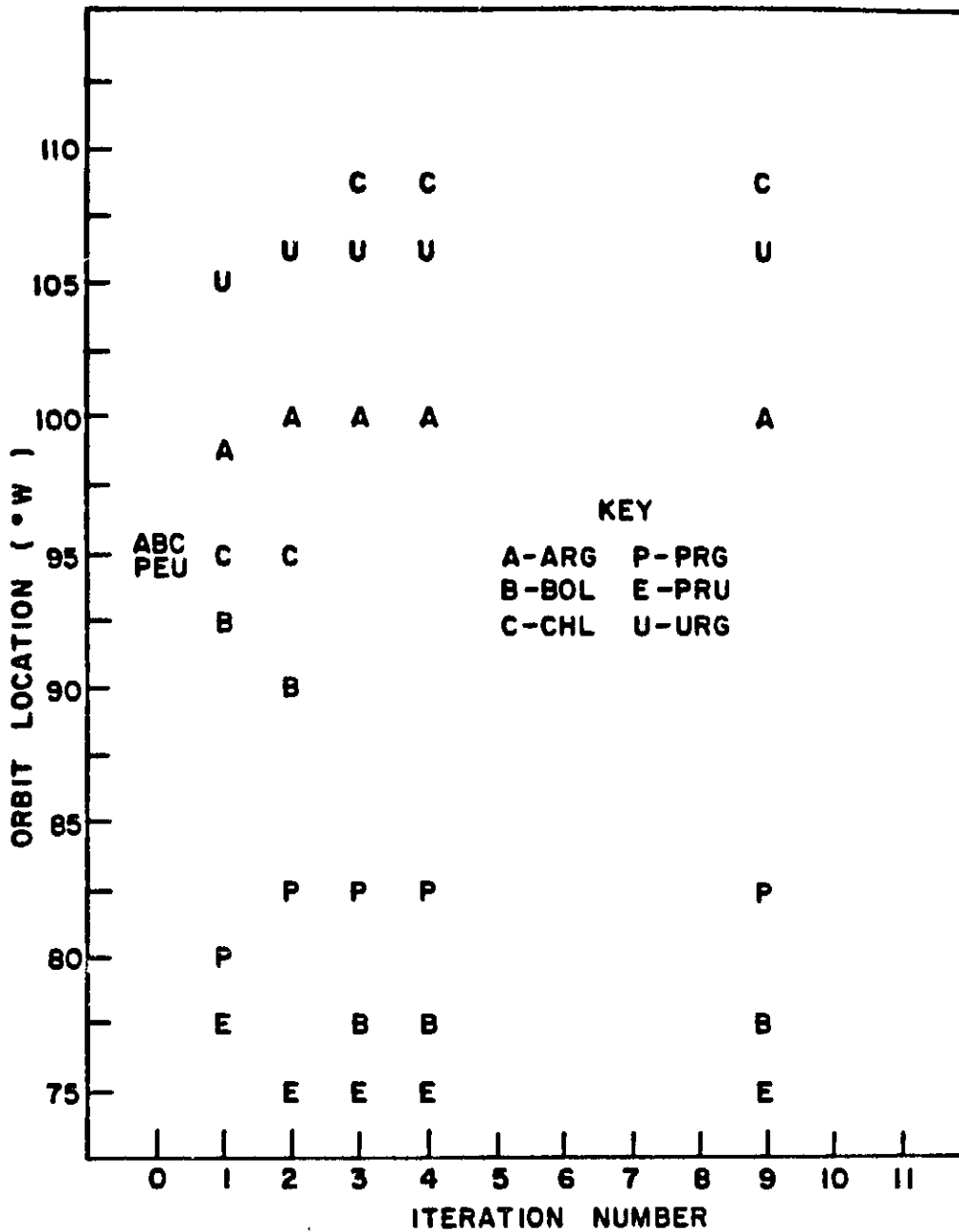

Figure 14. Satellite orbit locations for each service area vs. iteration number. Run 2. See Figure 13 for initial scenario.

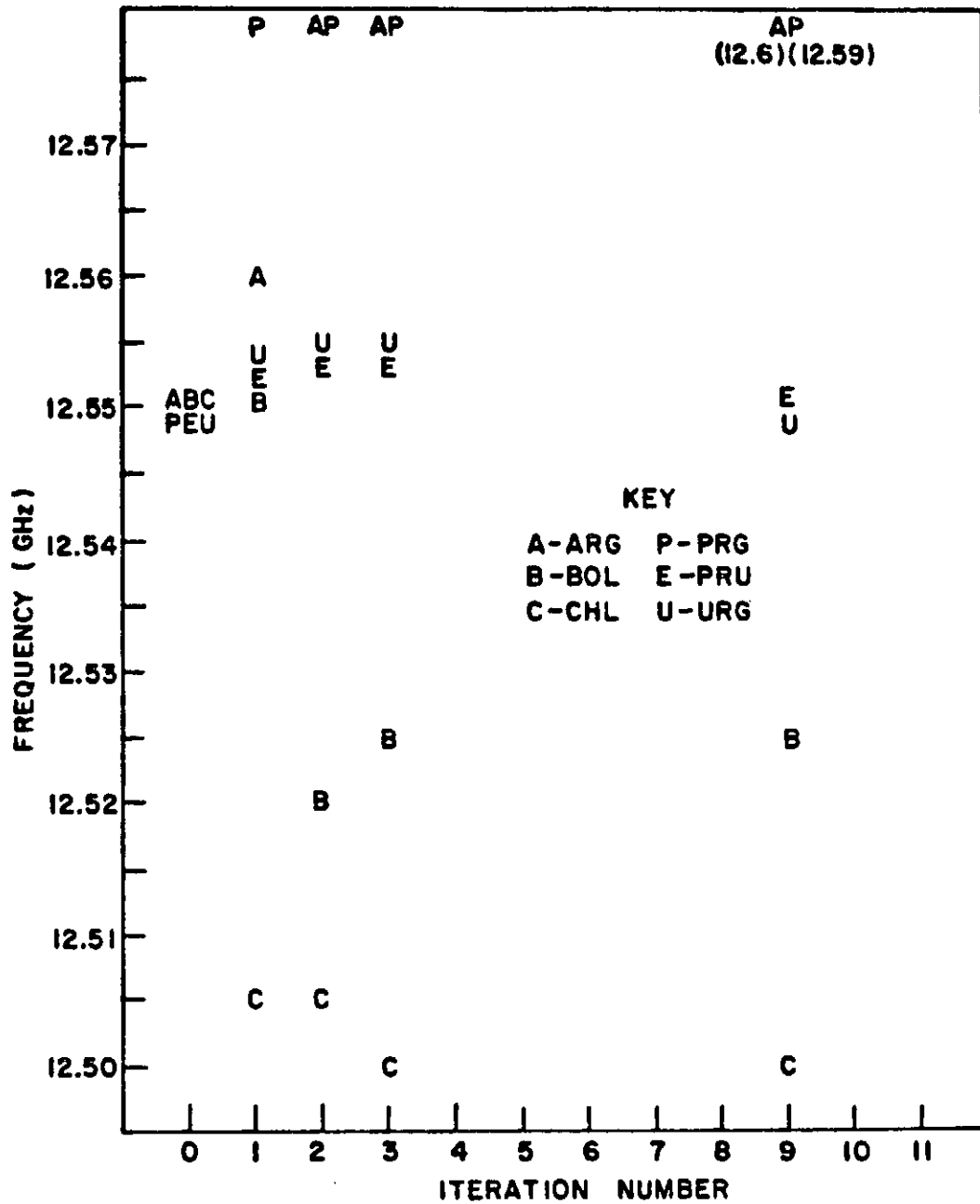

Figure 15. Reference frequency assignments vs. iteration number.
Run 2.
See Figure 13 for initial scenario.

Figures 14 and 15 also illustrate that it is possible for satellites to cross over one another in terms of both location and frequency. This means that the ordering of the satellites by position and frequency in an initial or an intermediate solution does not necessarily preclude finding an improved solution with a different ordering of the satellites. For example, compare the satellite locations at the third and fourth iterations in Figure 14.

The fact that the best solution to date for the six-administration model is obtained when an extremely "poor" starting solution is used is consistent with other empirical findings in mathematical programming. It is well known that moving away from a bad solution can produce better results than moving from a reasonably good solution.

The third scenario to be presented here is similar to the second in that the satellites are collocated and share the same frequency. However, the satellites are collocated close to the easternmost limit of their available arc. The computer results for this scenario are summarized in Figures 16, 17, and 18.

The solution obtained after nine iterations is not nearly as good as the final solutions found for the other scenarios. There is at least one aggregate C/I ratio of 16 dB. The frequencies were spread out quickly, but the satellites remained rather close together. It appears that the satellites were blocked from westward movements by the Peruvian satellite. The gradient pointed toward the nearby eastern boundary. The satellites were continually dispersed, but at a relatively slow

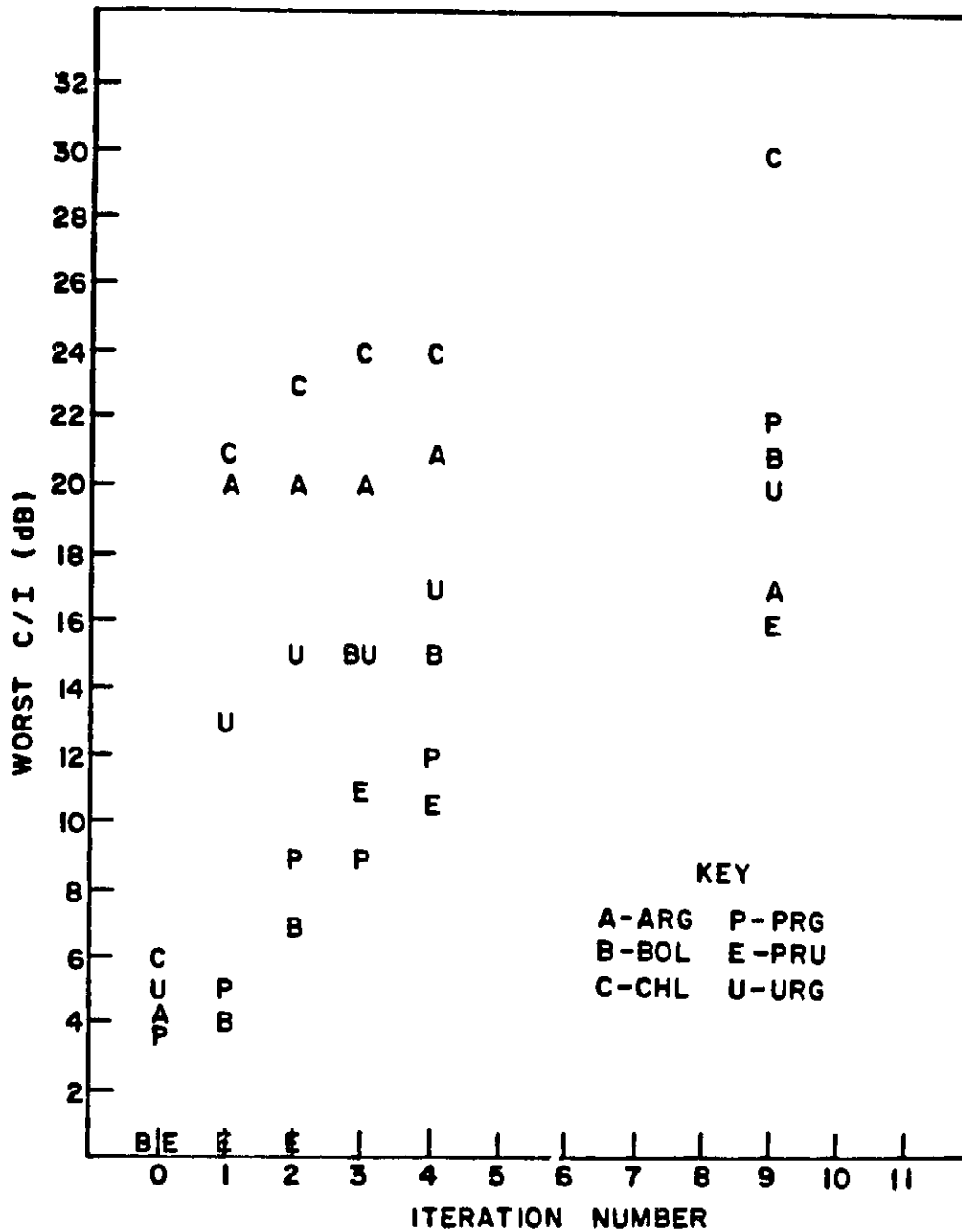

Figure 16. Worst C/I ratio for each service area vs. iteration number. Run 3.
Initial scenario: all satellites and reference frequencies collocated at 80° W and 12.53 GHz, respectively.

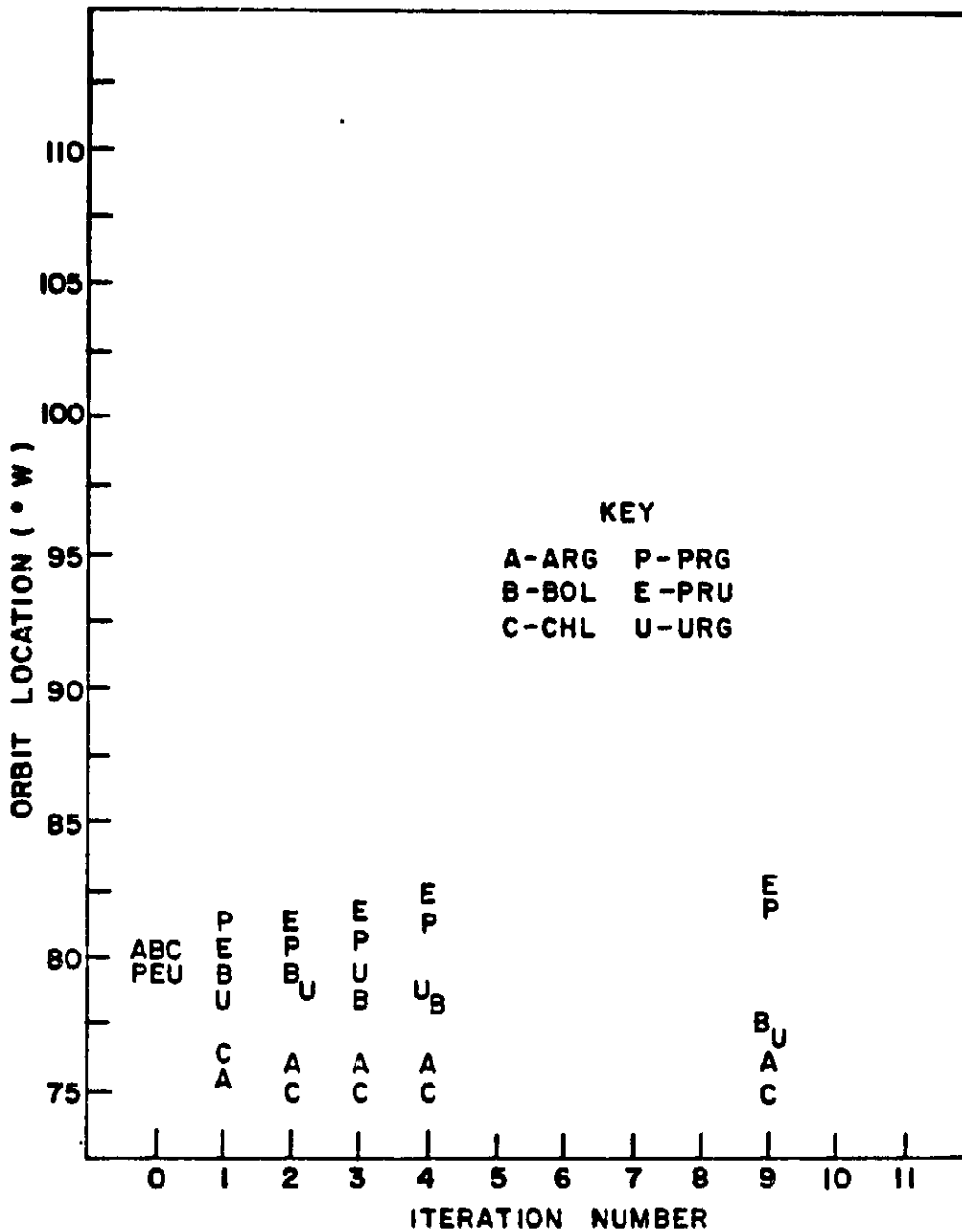

Figure 17. Satellite orbit locations for each service area vs. iteration number. Run 3. See Figure 16 for initial scenario.

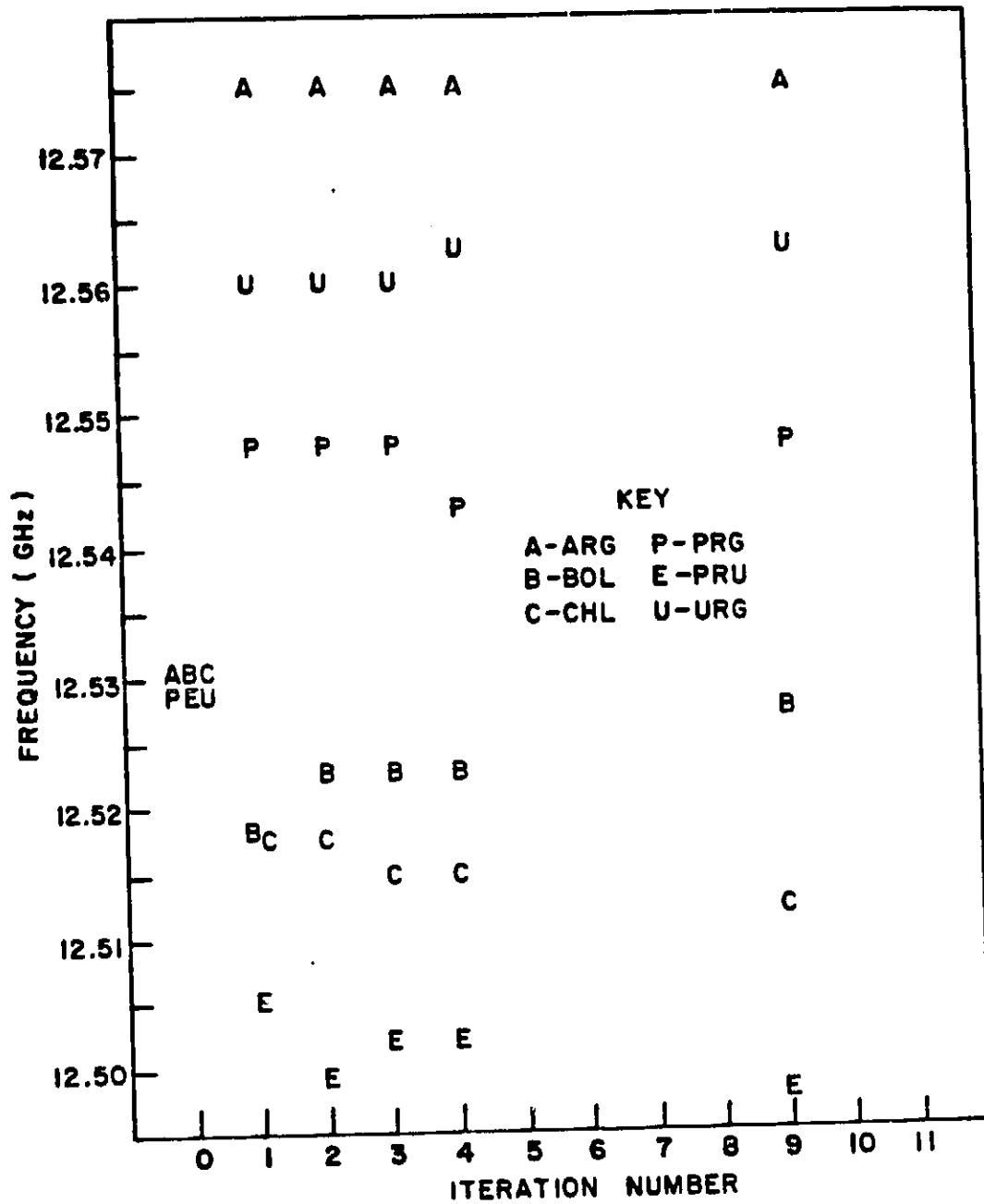

Figure 18. Reference frequency assignments vs. iteration number.
 Run 3.
 See Figure 16 for initial scenario.

rate. Each successive iteration produced an improved solution, but the rate of improvement was slow. If the gradient search procedure had not been terminated after only nine iterations, it is possible that a significantly better solution could have been found.

We have been able to draw some conclusions about the gradient search procedure following our computer experiments. Not every conclusion is surprising, but each can be substantiated with empirical evidence. First, for a small, fixed number of iterations, the gradient search procedure is highly sensitive to the initial scenario. Secondly, the use of an extremely unattractive starting scenario can produce a good solution rather quickly. The positioning of satellites near an orbital location boundary can dramatically slow the rate of improvement in successive solutions; positioning all satellites toward the middle of the available orbit and frequencies toward the middle of the available spectrum seems to result in the finding of good solutions fairly rapidly. Finally, satellites can cross over one another in terms of their locations and frequency assignments.

The six-administration model has been an invaluable tool in our analysis of the objective function surface of the BSS synthesis problem. We plan to continue to exercise this model to aid us in our future efforts.

V. FORMULATION OF THE FSS SYNTHESIS PROBLEM

A. INTRODUCTION

The purpose of an FSS Synthesis Procedure is to allocate satellite orbit locations and frequency bands in such a way as to satisfy a stated set of communications tasks with a minimum stated quality index while maintaining the greatest possible freedom to add additional services at a later time. One possible way of giving flexibility for adding additional services later is to minimize the frequency band occupied, or the orbital arc used, or a combination of the two.

Stated in this general way, the problem appears straightforward, well defined, and quite similar to the BSS synthesis problem. Indeed there are strong similarities, and these lead to the tentative conclusion that the gradient-search algorithm will find application in FSS synthesis. However, there are also very important, although subtle, differences. It has taken us a substantial part of the interim to begin to understand these differences. We have come to the conclusion that the FSS synthesis problem is as yet defined incompletely, and that perhaps one of our first functions has to be to point out the need for a clearer definition if highly efficient use of the spectrum and orbit for FSS purposes is to be addressed in the WARCs.

B. SIMILARITIES BETWEEN BSS AND FSS SYNTHESIS

An important similarity between the FSS and BSS synthesis problems is the similarity of the corresponding analysis procedures. This

similarity derives from the fact that the system configurations are identical: in each case a signal is transmitted from an earth station to a satellite and is then retransmitted (usually in a different frequency band) from the satellite to another earth station or group of earth stations. For example, in either the FSS or BSS case, it is necessary to compute the interference on the downlink to an earth station from an interfering satellite signal. The situation is shown schematically in Figure 19. The symbol E_w designates the earth station or test point where the C/I ratio is to be calculated. S_w and S_I designate the satellites radiating the wanted and interfering signals, respectively. $\hat{R}_{S_w}, \hat{R}_{S_I}$ designate the pointing direction unit vectors for the two satellites, respectively. Similarly \hat{R}_{S_w, E_w} and \hat{R}_{S_I, E_w} designate the unit vectors pointing toward Earth station E_w from the respective satellites, and $\hat{R}_{E_w, S_w}, \hat{R}_{E_w, S_I}$ are unit vectors pointing from Earth station E_w toward the respective satellites. Then the carrier-to-interference ratio for this single interference entry is given by

$$\frac{C}{I} = \frac{P_{S_w}^i D_{S_w}^T (\hat{R}_{S_w}, \hat{R}_{S_w, E_w}, G_{S_w}^T) R_{S_I}^2}{P_{S_I}^i D_{S_I}^T (\hat{R}_{S_I}, \hat{R}_{S_I, E_w}, G_{S_I}^T) D_{E_w}^R (\hat{R}_{E_w, S_w}, \hat{R}_{E_w, S_I}, G_{E_w}^R) R_{S_w}^2} \quad (5)$$

where P^i denotes the effective isotropic radiated power radiated from the satellite designated by the subscript and D^T, D^R designate the antenna discrimination patterns of the transmitting and receiving antennas, respectively, at the location indicated by the subscript.

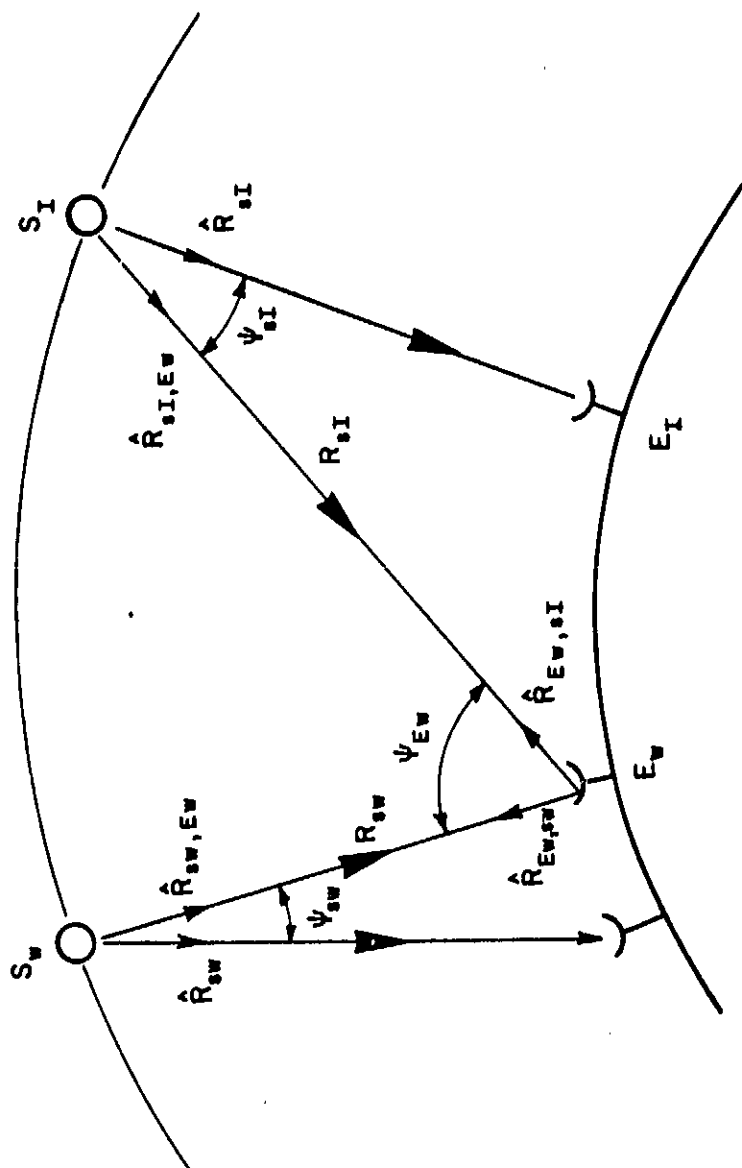

Figure 19. Schematic representation of the spatial relations between satellites and Earth stations. E stands for Earth station, s for satellite, w indicate the wanted communication channel, I part of an interfering network.

\hat{R} denotes a unit vector. Heavy arrows indicate signal transmission. The Earth stations need not be located at the same latitude.

This directivity is a function of the unit vectors (directions) and gains indicated in the arguments. In the case of circular beams, the unit vectors in the directivities can be replaced by the angles ψ , where ψ_{EW} for example is given by

$$\psi_{EW} = \cos^{-1} (\hat{R}_{EW,SW} \cdot \hat{R}_{EW,SI}) \quad (6)$$

An analysis program, such as SOUP, calculates the C/I ratio on an aggregate basis. For this purpose the denominator in Equation (5) is replaced with a sum of terms of the same form, one term for each interfering satellite. The total C/I ratio is then determined by calculating the uplink C/I in a similar way and combining the two according to

$$\frac{C}{I} \text{ total} = \left[\frac{C}{I} \text{ up} + \frac{C}{I} \text{ down} \right]^{-1} \quad (7)$$

The very same calculation can thus apply to either the BSS or FSS case as far as the calculation of C/I is concerned. Of course the allowable C/I ratio may differ for the two cases since the signals and modulation methods may be quite different, but the method of calculation is the same. This similarity is the basis for our belief that the gradient-search will be useful for the FSS synthesis calculation also, and that the existing BSS codes are a useful test bed for evaluating gradient-search procedures intended for FSS application.

C. DIFFERENCES BETWEEN BSS AND FSS SYNTHESIS

1. Importance of the Uplink

While the mathematics of the optimization for the BSS and FSS synthesis are closely related, there appear to be differences in the structures of the basic synthesis problems for the two cases. Some of these are minor, while others seem quite important, although subtle.

One difference which appears relatively innocuous to us is the importance of the uplink. In the BSS synthesis, the role of the uplink is relatively minor. The reason becomes apparent when one considers the impact of economics on the antennas for the two half links. For the antennas on the satellite, there is no compelling reason to make either antenna much better or larger than the other, but for the earth stations the relatively few uplink antennas can be much more directive (and expensive) than the vast multitude of consumer downlink antennas. Thus the downlink is inherently much more susceptible to interference, and orbital assignments must be made primarily on the basis of downlink considerations. The term involving $(C/I)_{up}$ in Equation (7) can, therefore, be neglected, at least to first order.

This is not true for the FSS case, since the consumer must have both an uplink and downlink antenna in this case for duplex communication, the most usual application. Both terms in the equation will normally be about equally significant. However, this does not change the basic character of the computations. Equation (7) can be rewritten as

$$\frac{I}{C} \text{ total} = \frac{I}{C} \text{ up} + \frac{I}{C} \text{ down} \quad (8)$$

Minimizing the sum of two terms may entail about twice the computation time compared with that for just one term, but it is not inherently more difficult. This is why we called the difference in the importance of the uplink for the two cases "innocuous".

2. Time Division [3,4]

Broadcasting stations generally operate on an essentially continuous basis. This is not true necessarily of FSS stations. For many applications it is possible to operate in a burst mode, in which a station transmits information in brief bursts interspersed with silent periods, which can be used for transmissions by other stations. Such a system is said to employ time-division multiple access (TDMA). TDMA systems can be subdivided further into two classes: demand multiple access (DMA) and random access systems. In DMA systems, access is on a controlled basis. For example, in systems using a "polling" protocol, a single station acts as controller and polls (i.e., queries) each other station, in turn, as to whether it has messages to transmit. It then assigns channels accordingly. In a "token-passing" protocol, the stations act as controllers in turn. One station starts in control and transmits its messages, it then uses a code called the "token" to transfer control to the next station in the chain, and so on. An alternative type of DMA protocol, which allows access in arbitrary order in a DMA system, is to use a separate channel as an "order wire" by

which any user can request a channel from the master control station, which responds by assigning a time-slot sequence.

In random-access protocols, no station exercises control over the transmission sequence. A common random-access protocol is the ALLOHA system, or modifications thereof. In an ALLOHA system, the sender simply transmits the message when he chooses. If another station is transmitting simultaneously on the same channel, interference will result; otherwise the message will be received and acknowledged. If the sender does not receive an acknowledgment, he retransmits the message after a specified time interval. Another form of random access is carrier-sense multiple access (CSMA). In this protocol, a user wishing access to a given channel first must listen to that channel. If the channel is clear, the user transmits his message; if it is busy, as evidenced by presence of a carrier, the user must wait a predetermined period and then try again.

This listing of multiple-access protocols is by no means complete. It is meant to convey mainly the great variety of time-division schemes which have been proposed, all of which have advantages and disadvantages depending on the particular application and user environment.

In principle, time-division might be used as a basis for permanent resource assignment as well as for operational protocol. The advantages would be clearest for a coordinated DMA system. For example, consider a satellite located so as to receive messages from the Eastern United States time zone. Such a satellite, if used continuously, could not receive the same frequency from Eastern Canada; but if used in a DMA

mode with narrow switched beams, the same frequency could be reused for Canada during the time slots when the U. S. beam is directed toward the southern part of the zone. Thus switched-beam DMA operation could, in principle, improve the spectrum/orbit utilization.

However, it seems likely to us that international assignment procedures will be based for some time to come on continuous use, rather than time-division switched beam technology. One reason is that to include time-division assignments would complicate the assignment process, which is already exceedingly complex. A second is that assignments are currently made on a continuous-use basis. A third is that satellites in the lower frequency bands, which are most crowded and, therefore, in most need of attention, generally operate currently on a continuous basis.

We will, therefore, restrict our synthesis procedures to assignments which would allow each satellite to operate continuously. Of course an assignment plan developed on this basis will not preclude the use of a time-division protocol in operation; if continuous operation does not cause unacceptable interference, part-time operation will not do so. However, the spectrum-orbit-time utilization will not necessarily be optimized fully for the TDMA case. This is the price for simplifying the synthesis, consistent with the belief that coordination between administrations in the time domain is not likely in the current time frame.

3. Service Areas

The concept of service areas, combined with that of appropriate antenna beams, turns out to be crucial in making good spectrum/orbit assignments for FSS systems. The basic principle can be demonstrated heuristically by considering a half-link, e.g., a down-link. In this case, the single-entry interference received at an earth-station receiver from an interfering satellite is proportional to the discrimination of its receiving antenna in the direction of the interfering satellite times the discrimination of the interfering satellite transmitting antenna in the direction of the earth station. If the satellite is intended to serve a very wide geographical area, such as earth-coverage, the satellite antenna discrimination will be small and the interfering satellite must be located far from the satellite being received by the earth station so that its receiving antenna will have sufficient discrimination. In contrast, if the interfering satellite has a smaller, non-overlapping service area and its beam is correspondingly narrower, it will discriminate more toward the earth station, and less discrimination by the earth-station antenna will be required, thus allowing closer satellite spacings. Similar considerations apply to the uplink.

This interrelation between defined service areas, correspondingly narrow-beam antennas aboard the satellites, and the allowable satellite spacing and total capacity of the geostationary orbit has been understood qualitatively by industry and those intimately involved with the CCIR for some time [5,6]. For example, the replacement of INTELSAT

IV with IV-A satellites was motivated at least in part by the capability to "reuse" frequency channels by replacing the earth-coverage beams in the type IV satellites with hemispherical coverage beams in the type IV-A. At the time when we began looking at the FSS synthesis problem, little of this thinking was reflected in the literature, nor was it common knowledge in the working groups with which we met, and it required some time to evolve these concepts ourselves. Since then, some literature touching on these concepts in a qualitative way has become available [5,7]. It seems to us that a more quantitative understanding will be essential in arriving at better assignment procedures. The first steps in this direction have been taken. We are exploring the production of a series of aids for estimating, on a single-entry basis, the effects of system parameters on FSS spectrum/orbit utilization. These aids may turn out to be universal curves, simple formulas derived by regression analysis, or interactive computer programs, as the situation dictates.

As an example calculation, consider first the case of no service area assignments, as illustrated at the top of Figure 20. A single earth receiving station is shown. A desired carrier is being received from satellite FSS_w , while an interfering carrier I arrives from FSS_I . It is assumed that the earth station antenna is pointed at FSS_w and that the FSS_w transmitting antenna is pointed at or near the Earth station. Since no service areas are assigned, in the worst case the FSS_I transmitting antenna may be pointed very nearly at the same Earth station. We assume this worst case. Then Equation (5) reduces to

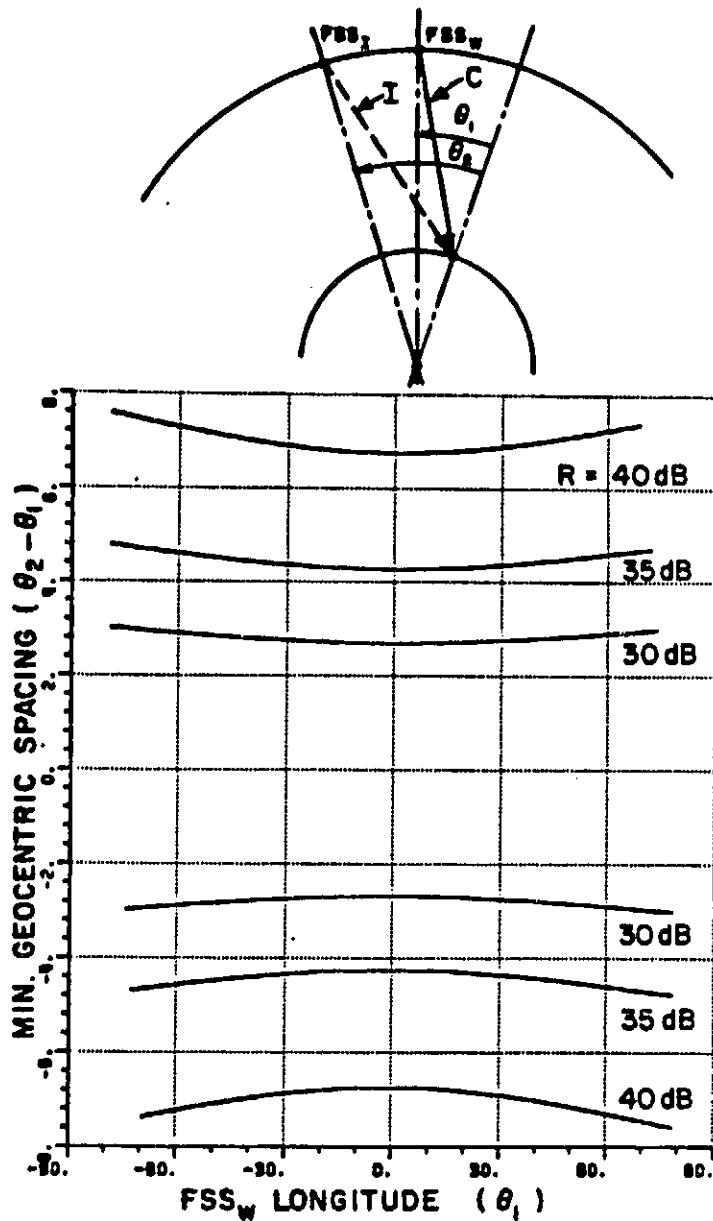

Figure 20. Minimum orbital spacing for Earth-coverage satellite assignments, based only on down-link considerations. The system parameter R is defined in Eq. (11). The Earth station antenna gain is 50 dB, its latitude is 40° N. The directivity pattern is that adopted by WARC-79 [8]. The satellite longitude is given relative to its earth station.

$$R = \frac{1}{D_{EW}^R \left[\psi_{EW} (\phi_{SW} - \phi_{EW}, \phi_{SW} - \phi_{SI}, \lambda_{EW}), G_{EW} \right]} \quad (9)$$

where advantage has been taken of

$$R_{SW}^2 = R_{SI}^2 \quad (10)$$

and the "universal" system parameter R is defined by

$$R = \frac{C}{T} \text{ required} \cdot \frac{P_{SI}^1}{P_{SW}^1} \quad (11)$$

A typical plot appears at the bottom of Figure 20. It is evident that the elevation of FSS_w as seen from its earth station has very little effect on the minimum allowable satellite separation; for the parameters used in Figure 20 the required separation would be about 5° when $R = 35$ dB. When satellites with a full complement of transponders, i.e., covering all allowed frequency bands, are placed over the useful orbital arcs with a separation of about 5° the orbit would be said to be "full". The particular value 5° is a function of the system variables entering into R, see Equation (11), of the earth station gain and discrimination pattern, and to a minor degree of the Earth station latitude. The discrimination patterns used for Earth and satellite antennas throughout this report are taken from CCIR reports [8,9].

We are still looking for the best way to display this type of information for all relevant values of the variables. It should be

noted that the system design approach taken in this example is precisely the one which has been used in the past in determining compatible assignments in the 4/6 GHz band: the satellite antennas have broad Earth-coverage or hemisphere-coverage patterns, and the allowable spacing is determined by the discrimination of the Earth station antennas. The orbit has been "full" for some time in the 4/6 GHz band, and attempts are under way to allow closer satellite spacings by requiring Earth station antennas to have better discrimination in the near-sidelobe region.

Consider now the case illustrated by Figure 21. Satellite FSS_W transmits to its Earth station E_W with its beam maximum pointed at the station. Similarly satellite FSS_I transmits to its Earth station E_2 , and its antenna is pointed at E_2 . However, we now assume that, because of service area restrictions, E_1 and E_2 are separated and that the satellites use antennas with relatively high gain.

A few words are in order regarding the geometry of Figure 21. The calculation to be performed is the C/I ratio at Earth station E_1 , which is used as reference for the central angles θ_1 and θ_2 , which locate the satellites, and the central angle ϕ , which locates the longitude of the Earth station at which the interfering satellite is pointed. The ψ denote angles between antenna beam axes and directions where interference might be a problem; they are not central angles. Thus ψ_3 is the angle between the direction in which the E_W receiving antenna is pointed and the interfering signal source FSS_I , and ψ_2 is the angle between the FSS_I beam axis (toward E_1) and the Earth station E_W where the FSS_I signal produces interference. The separations are drawn large

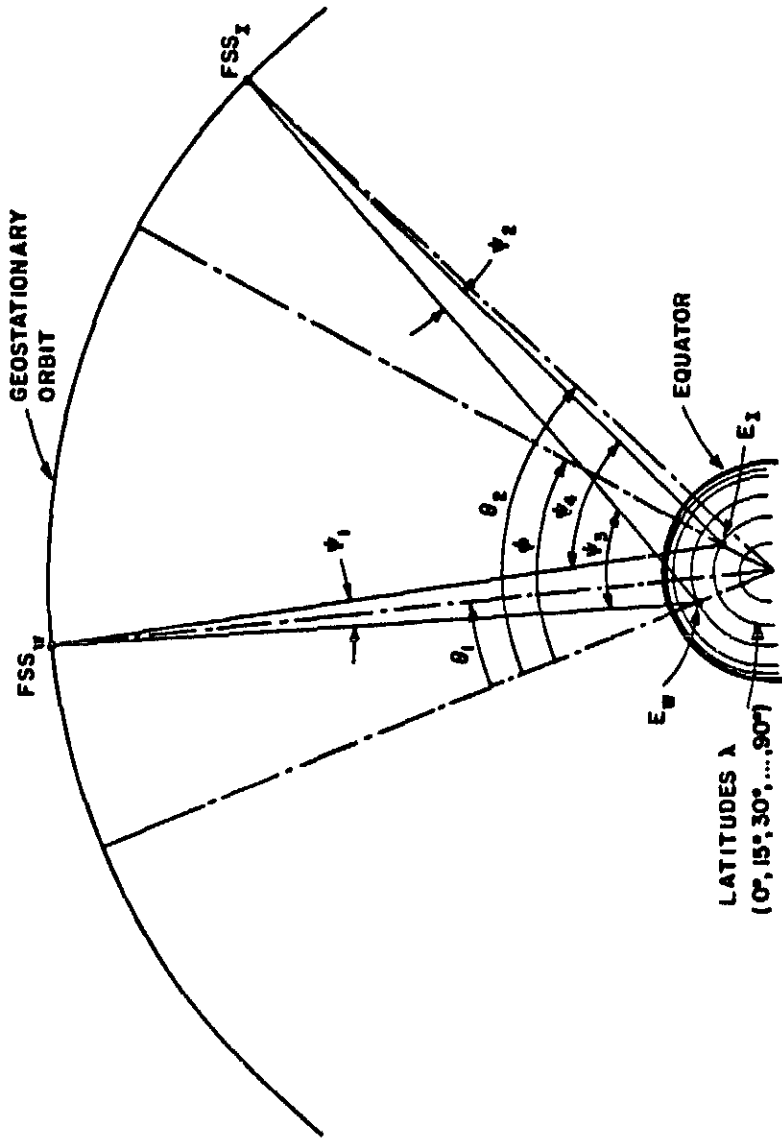

Figure 21. Geometry of Earth-stations and satellites, defining the angle variables. θ_1, θ_2, ϕ are central angles in the equatorial plane. The off-axis angles ψ_i do not lie in the equatorial plane. E_W and E_E are shown at latitudes of 45° and 60° for illustration; their latitudes are variable.

for clarity; in actual practice we are interested in small spacings $(\theta_2 - \theta_1)$ between the satellites and small spacings between E_1 and E_2 . Under these conditions, ψ_3 becomes nearly equal to the satellite spacing $(\theta_2 - \theta_1)$. Figure 22 shows the allowable satellite spacings ψ_3 for 50 dB gain antennas, corresponding to a circular beam approximately 1/2 degree wide between 3 dB points, as a function of the angle ψ_2 . These angles are the natural coordinates for the calculation, but they are not very helpful to the systems planner, who must deal with earth station locations in terms of longitude and latitude and with orbital locations in terms of longitude. The result for a universal system parameter value $R=35$ dB is replotted in Figure 23 as a set of contours in the plane in which the relative longitude θ_1 of satellite FSS_w is used as one coordinate and the required satellite orbital separation $(\theta_2 - \theta_1)$ is the other. The longitude ϕ of E_2 relative to E_1 is shown as an explicit parameter, while the antenna gains and Earth station latitudes, as well as the universal system parameter R , are implicit in the calculation. Comparison of Figure 23 with Figure 21 shows that much closer satellite packing in the orbit can be achieved with increasing service area separation. Obviously a lot of parameters are involved in the problem and it is not clear how the information can best be made available to an engineer concerned with orbit/spectrum resource allocation. More work is required on this task.

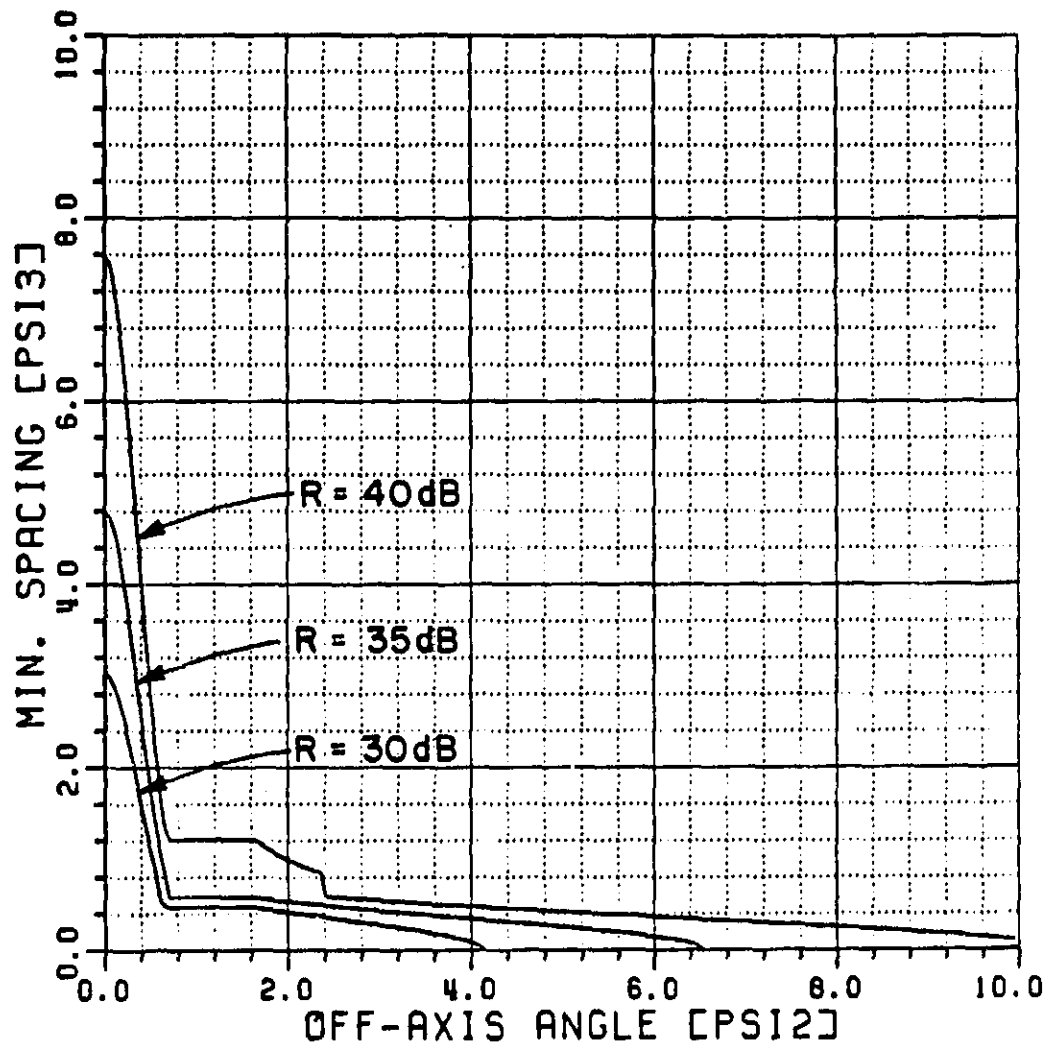

Figure 22. Allowable satellite spacings as function of minimum Earth station separation, given in terms of off-axis angles. $G_{EW} = G_{SI} = 50$ dB. Directivity patterns are taken from CCIR Reports 391-4 [8] and 558-2 [9] for Earth and space antennas, respectively.

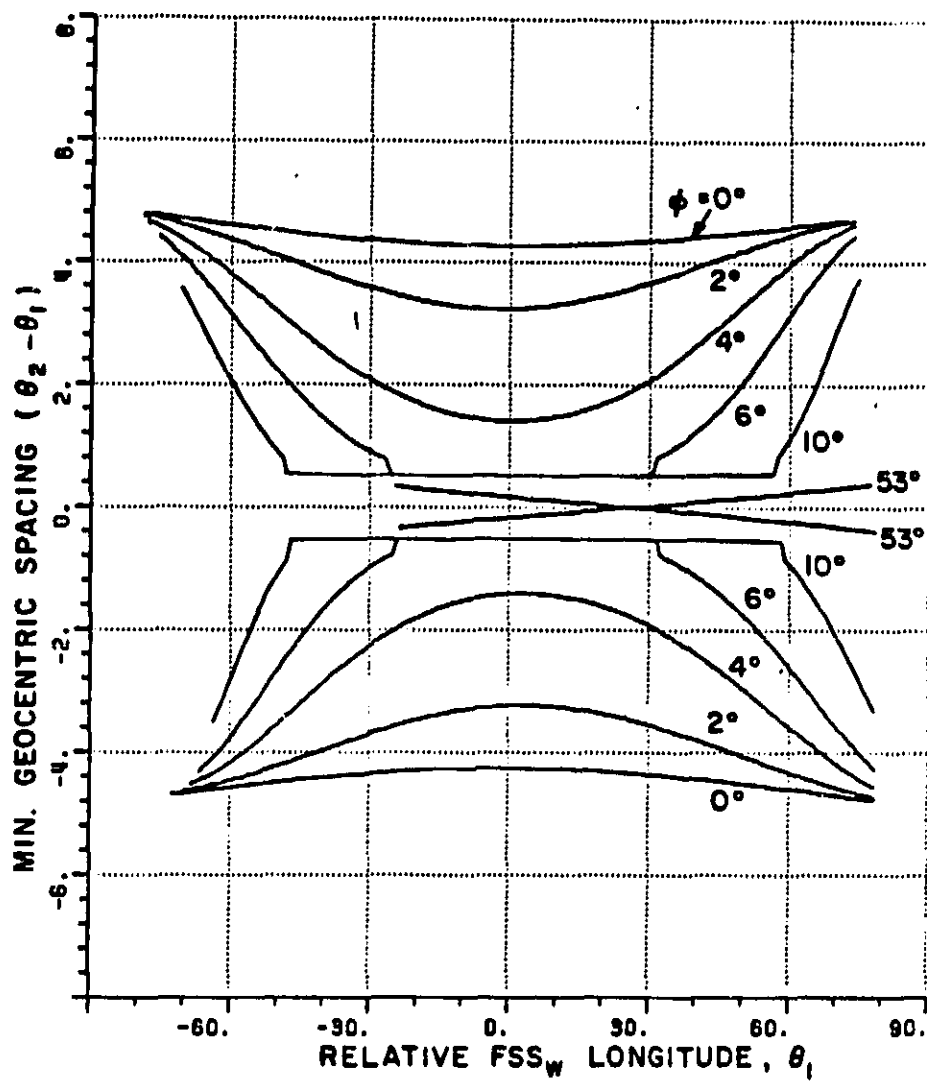

Figure 23. Minimum satellite spacing when Earth stations are separated a minimum longitude difference ϕ by service area assignment. Parameter values: R (see Eq. 11) = 35 dB, $G_{Ew} = G_{s1} = 50$ dB, with both Earth stations at latitude 40° N.

4. Beam Shaping

Antenna beams which are shaped to fit the service areas they are intended to cover not only minimize interference to other service areas, but they also utilize the satellite transmitter power most effectively. Thus there exists a substantial incentive for the use of shaped-beam technology in satellites for the FSS. An informal inquiry by one of the Principal Investigators from a few good acquaintances in the satellite-antenna industry showed that almost all the manufacturers contacted have computer codes for designing shaped beams, and that most consider these codes proprietary. It is not clear whether a reference pattern can be developed, akin to those which have been developed for circular and elliptical beams, for the large variety of patterns which may be utilized [10]. Such a reference pattern would of course be very useful for calculations related to managing the spectrum/orbit resource.

For the present we have decided to consider only circular and elliptical beams, for which reference patterns are available [8,9]. A large number of service area shapes can be covered with these patterns with sufficient accuracy to show the effects of using different service area shapes and sizes. It seems to us that the problem of FSS synthesis is sufficiently complex even with these simple shapes and exhibits all the essential features, so that shaped beams can be included at a later date, when and if reference patterns for such shapes become available.

5. The Formulation of Requirements

In the BSS synthesis, the design objective is specified in terms of a "requirement file", i.e., a listing of the number of channels desired for each service area. The BSS synthesis program is then intended to accommodate these requirements with the use of the least possible spectrum/orbit resource. In our synthesis procedure, this is accomplished by starting with a relatively large total bandwidth and optimizing orbit and channel assignments; if the required C/I ratio is then exceeded at all test points, the program is repeated with a smaller total bandwidth, and so on until the C/I ratio requirement is barely met.

For the FSS synthesis, the requirements file or list must be generalized. Any synthesis code one might write will depend on the form this generalization will take, and our experience with the BSS synthesis has shown that a lot of effort can be consumed in adapting such a code later to a changed requirement format. From the point of view of the FSS synthesis task it would, therefore, be useful to arrive at a format for stating FSS requirements as soon as possible, perhaps at the WARC-85. However, it is not clear that other technical and non-technical considerations will allow an early resolution of this matter.

A possible way of stating the FSS requirements for synthesis purposes is illustrated in Figure 24, which considers the spectrum/orbit allocation for six South-American administrations. These were picked quite arbitrarily because convenient ellipse files for them happened to

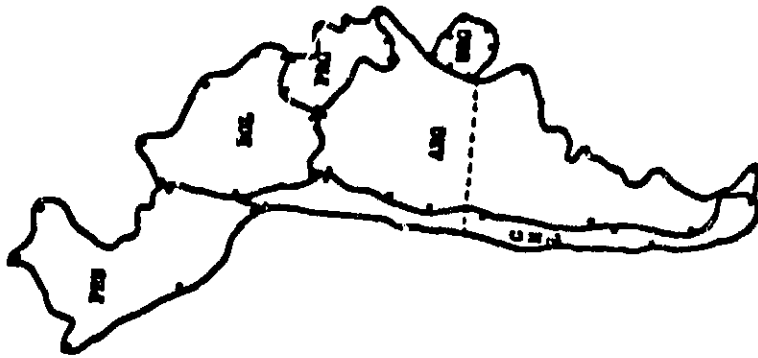

[A]

	ARG	BOL	CHL	PRG	PRU	URG
ARG						
BOL						
CHL						
PRG						
PRU						
URG						

[B]

	ARG 1	ARG 2	BOL	CHL 1	CHL 2	PRG	PRU	URG
ARG 1								
ARG 2								
BOL								
CHL 1								
CHL 2								
PRG								
PRU								
URG								

Figure 24. Proposed requirements table. The six service areas are shown at left. At right top the table is set up treating each administration as one service area; at right bottom, Argentina and Chile have been divided into two service areas each.

be available to us. A requirements matrix can be formulated by filling in the table at the top right of the figure with the number of channels required to service the desired traffic flow from the administration listed at the left of a given square to the administration listed at the top of the column to which the square belongs. If the administrations are numbered 1,2,...,6 according to the alphabetical order of their symbol, the table can be represented as a matrix [A] of positive elements a_{ij} . A measure of the total communication capacity required is then given by

$$C_A = \sum_{i=1}^6 \sum_{j=1}^6 a_{ij} \quad . \quad (12)$$

Such a model can be used to show the effect of decreasing the service area size. For example, it might be noted that the long north-south dimensions of Chile and Argentina, compared with their respective east-west dimensions, leads to ellipses which may be difficult to implement and which may have a relatively high likelihood of interfering with other service areas. It might, therefore, be proposed to subdivide these two administrations each into a northern and a southern service area. The resulting requirements matrix [B] will be of size 8 x 8 and will have total communication capacity

$$C_B = \sum_{i=1}^8 \sum_{j=1}^8 b_{ij} \quad . \quad (13)$$

To the extent that the new service areas have decreased the mutual interferences and thus enhanced the opportunity for frequency reuse,

one would expect to find that $C_B > C_A$. This calculation might be attempted as a computer experiment during the next interim. At the moment the concept is presented mainly to stimulate discussion in the technical community, and we shall be grateful for any feedback.

VI. CONCLUSIONS AND PLANS FOR THE NEXT INTERIM

A gradient-search code for BSS synthesis was completed. Efforts to use it with the RARC-83 output scenario have been unsuccessful, primarily because of changing or inconsistent information about the format of that scenario. Changes in the program were also required to allow for channel family instead of block assignments and to produce preassigned fixed frequencies for the starting points of the channel families. These problems are nearing resolution.

The basic properties of the objective function surface were investigated using a very simple model: two satellites, each with a single channel. The surface was found to be neither concave nor convex even for this very simple case.

To get further insight into this function, computational experiments were carried out using the South American six-administration model and extended gradient search described previously. It was found that very significant improvements were generally obtained in very few iterations, that satellites could cross over (i.e., change ordering) during the procedure both in orbit location and frequency, and that best results were obtained with a starting scenario in which both orbit locations and frequencies were collocated near the center of their

respective ranges. Most important, the model is an excellent tool for obtaining a better understanding of the objective function surface and gradient-search procedure.

The formulation of the FSS synthesis problem shows some striking similarities and also striking differences with reference to the BSS synthesis. Expressions for the single-entry and aggregate C/I ratios were obtained, and they are closely related to the corresponding expressions for the BSS case. Therefore, the gradient-search method should be equally applicable. Nevertheless the formulation of the problems are quite different, primarily because natural service areas are not defined as easily for the FSS case. A definition of orbit/spectrum capacity is proposed, and it is shown that the capacity increases for small service areas. A means of specifying the requirements is suggested; it generalizes the linear list of the BSS case to a square matrix or two-variable list for the FSS case. The potential for time-division multiple access and the common use of shaped antenna beams are two other factors which differentiate the FSS synthesis problem from that of the BSS case, but it is felt that these can be ignored for the present without changing the basic nature of the task or usefulness of the results.

Work is continuing in two areas: FSS synthesis, and also the production of design aids (such as universal charts, nomograms, and interactive computer codes) which will give significant insights on a single-entry basis.

REFERENCES

- [1] C. A. Levis, C. H. Martin, D. Gonsalvez, and C. W. Wang, "Engineering Calculations for Communications Systems Planning", Technical Report 713533-3, The Ohio State University ElectroScience Laboratory, Dept. of Electrical Engineering, Prepared under Grant NAG 3-159 for NASA/Lewis Research Center, Cleveland, Ohio.
- [2] J. Davidson and P. Sawitz, "Spectrum/Orbit Utilization Program User and Programmer's Manual". ORI, Silver Spring, MD under Contract NAS3-22884 for NASA/Lewis Research Center, 1981.
- [3] Engineering Staff, Scientific-Atlanta, "Broadband Multi-Access Techniques". Telecommunications, June, 1984, pp. 75-80.
- [4] CCIR Report 708-1 "Multiple access and modulation techniques in the fixed-satellite service". Recommendations and Reports of the CCIR, 1982, Vol. IV, Part 1. International Telecommunication Union, Geneva, 1982.
- [5] D. M. Jansky and M. C. Jeruchim, Communications Satellites in the Geostationary Orbit, Artech House, 1983. Sections 5.7, 5.12.1.
- [6] CCIR Report 453-3 "Technical factors influencing the efficiency of use of the geostationary-satellite orbit by radiocommunications satellites sharing the same frequency bands". Recommendations and Reports of the CCIR, 1982, Vol. IV, Part 1. International Telecommunication Union, Geneva, 1982.
- [7] D. M. Jansky and M. C. Jeruchim, op. cit., p. 254.
- [8] CCIR Report 391-4 "Radiation diagrams of antennas for Earth stations in the fixed-satellite service for use in interference studies and for the determination of a design objective". Annex I. Recommendations and Reports of the CCIR, 1982, Vol. IV, Part 1. International Telecommunication Union, Geneva, 1982.
- [9] CCIR Report 558-2 "Satellite Antenna Patterns in the fixed-satellite service". Figure 13. Recommendations and Reports of the CCIR, 1982, Vol. IV, Part 1. International Telecommunication Union, Geneva, 1982.
- [10] Ibid., Section 5.