

NASA Technical Memorandum 86980

Nested Subcritical Flows Within Supercritical Systems

R.C. Hendricks
Lewis Research Center
Cleveland, Ohio

M.J. Braun and R.L. Wheeler III
University of Akron
Akron, Ohio

R.L. Mullen
Case Western Reserve University
Cleveland, Ohio

Prepared for the
20th Annual Cavitation and Multiphase Flow Forum
sponsored by the American Society of Mechanical Engineers
Albuquerque, New Mexico, June 24-26, 1985

NASA

NESTED SUBCRITICAL FLOWS WITHIN SUPERCRITICAL SYSTEMS

R.C. Hendricks
National Aeronautics and Space Administration
Lewis Research Center
Cleveland, Ohio 44135

M.J. Braun and R.L. Wheeler III
University of Akron
Akron, Ohio 44325

R.L. Mullen
Case Western Reserve University
Cleveland, Ohio 44106

ABSTRACT

In supercritical systems the design inlet and outlet pressures are maintained above the thermodynamic critical pressure P_C . Designers rely on this simple rule of thumb to circumvent problems associated with a subcritical pressure regime nested within the supercritical pressure system along with the uncertainties in heat transfer, fluid mechanics, and thermophysical property variations. The simple rule of thumb is adequate in many low-power designs but is inadequate for high-performance turbomachines and linear systems, where nested two-phase regions can exist. Examples for a free-jet expansion with back-pressure greater than P_C and a rotor (bearing) with ambient pressure greater than P_C illustrate the existence of subcritical pressure regimes nested within supercritical systems.

NOMENCLATURE

C clearance, cm
D diameter, cm
 D_C density at thermodynamic critical point, g/cm^3
i index indicating inlet number
e eccentricity
G mass flux, $g/s\ cm^2$
 G_r reduced mass flux, G/G^*
 G^* thermodynamic parameter, $\sqrt{P_C \rho_C / Z_C}$,
6010 $g/s\ cm^2$ for nitrogen
L spacer length, cm
 l aperture (orifice, Borda) length, cm
P pressure, MPa
 P_r reduced pressure, P/P_C

R radius
 R_g gas constant
S entropy, $J/g\ K$
T temperature, K
 T_r reduced temperature, T/T_C
 \dot{w} mass flow rate, g/sec
Z axial coordinate, cm
 Z_C compressibility factor, $P/\rho R_g T$
 θ circumferential coordinate, rad
 ρ density, g/cm^3
 η viscosity
 ω angular velocity

Subscripts
c thermodynamic critical point
e exit
in inlet
s static
0 stagnation

INTRODUCTION

Many current operational supercritical systems have been designed on a simple rule of thumb - maintain the design inlet and outlet pressures well above the thermodynamic critical pressure P_C to circumvent two-phase flow and other associated uncertainties in heat transfer, fluid mechanics, and thermophysical property variations. The simple rule

of thumb is adequate in many low-power designs but, as will be demonstrated, it is inadequate for high-performance turbomachines and linear systems.

Global thermodynamics permits local events that are considered unstable or unattainable when viewed in terms of total process dynamics. It becomes a matter of refining one's view of the black box containing the system.¹ For example, local "violations" of thermodynamics are termed metastabilities. Classic among these are the work of Skripov (1) and applied work such as fracture, boiling, and condensing (2,3). More recently the metastable character of water was investigated (4).

Thus the concept of a two-phase region nested within a supercritical region would be considered not only unstable but unrealistic. However, there is no reason for such an exclusion as it depends on the thermohydraulics that exist within components (the black box) operating at pressures above the thermodynamic critical point. Such conditions do not violate any thermodynamic hypotheses but are a source of incompatibility for the practicing engineer.

This paper demonstrates that two-phase regions can be nested within a supercritical pressure system. Furthermore conditions for the existence of nested zones are prevalent for sharp-edge inlets and for eccentrically loaded high-performance turbomachines operating above the thermodynamic critical pressure.

SIMPLE GEOMETRIES

Borda-Inlet Tube

Within a single-phase fluid, nested two-phase flows near sharp-edge inlets are commonplace and are in many cases represented as cavitation; however, the ambient pressure is subcritical. Consider the pressure profile of Fig. 1 (5-7). The inlet is sharp, and the L/D can be as high as 120 (6). The working fluid is nitrogen ($P_C = 3.417$ MPa, $T_C = 126.3$ K, $D_c = 0.3105$ g/cm³). The geometry is given in Fig. 1(a). The system was well instrumented and care was taken to maintain an adiabatic environment. For this configuration the inlet pressure was much greater than P_C , but the pressure just 0.54 mm (0.020 in) from the sharp-edge inlet was less than saturation based on stagnation conditions² $P_S(S_0)$. Downstream there is an immediate recovery toward $P_S(S_0)$, or pseudocritical³ $P(S_0)$, but full recovery could occur anywhere between this point and the exit as illustrated by the three different profiles. These profiles were achieved by two methods: inlet stagnation condition control, and exit backpressure control.

Inlet control. With controlled inlet stagnation conditions the pressure at the exit remained subcritical, but the pressure within the tube downstream of the inlet was supercritical for isotherms 127.8 K and 130.5 K (Fig. 1(b)). This fully defines a two-phase flow nested between two zones at supercritical pressure. These results are somewhat open to question⁴ as $S_0 > S_C$. However, $S_0 < S_C$ for run 1133

¹Perhaps as a fracture surface that when viewed from close up appears with discontinuities everywhere yet appears continuous and smooth when viewed from afar.

² $P_S(S_0)$ is the static pressure as a function of stagnation entropy.

³Pseudocritical: extrapolation of the saturation locus to the knee of the Joule-Tompson locus constrained by the loci of specific heat maximums.

⁴For $S_0 > S_C$, pseudonesting can occur, but two phases may not occur.

(Fig. 1(c), where the recovery pressure was greater than P_C . Run 1133 is inlet temperature controlled and nested, but the nesting is marginal.

Backpressure control. For run 1248 (Fig. 1(c)) the backpressure was increased sufficiently to move the pressure discontinuity ("shock") within the nozzle. A two-phase zone occurred but was at most weakly nested (all downstream pressures were less than P_C). For run 1547 the backpressure was increased above P_C , but there was little change in the two-phase zone within the tube nested between P_0 (at -27 cm) and P_e (at 0 cm), where P_0 and P_e are greater than P_C .

Four Sequential Axially Aligned Borda or Orifice Inlets

A more complex flow is established by a sequence of orifices or Borda apertures (8,9). The pressure profiles of Fig. 2(a) are for N Bordas in sequence with T_0 approaching T_C and backpressure dependent on downstream losses. The pressure signature here illustrates a nested set of two-phase zones within Borda 2, between the supercritical pressure zones of Borda 1 and Borda 3. With the inlet stagnation conditions constant the backpressure to Borda 4 was varied until $P_e > P_C$ within Borda 2; the two-phase zones remain nested between P_0 and P_e , which are both greater than P_C . Run 2879 (Fig. 2), illustrates that such zones can also exist within Borda 1. Because of an experimental facility limitation on P_0 , nested regions could be approached in Borda 3 but not fully established; exclusion is therefore not warranted for either Borda 3 or Borda 4.

For orifice flows, which may never choke, the pressures in the nested subcritical zones are often higher than saturation pressure. These zones shift to higher pressures as backpressure is increased and may not exhibit two-phase behavior (Fig. 2(b), orifice 2).

TURBOMACHINE CONFIGURATIONS

Normally seals and bearings for high-performance turbomachines operate at small eccentricities. However, during abnormal events or even the limit-cycle type of event, dimensionless eccentricities can approach 1 (rubbing).

Seals

Figure 3(a) illustrates the geometry of a high-performance turbomachine seal such as for the space shuttle main engine (SSME) (8,10). The working fluid is parahydrogen ($P_C = 1.2928$ MPa, $T_C = 32.976$ K, $D_c = 0.0314$ g/cm³). The pressure profiles (Figs. 3(b)-(d)) are for a fully eccentric, nonrotating shaft. The inlet pressure is greater than P_C , as is the pressure at the inlet to the third step (Fig. 3(b)). However, immediately downstream of the step the pressure on one "side" of the seal ($\theta = 0$) remains above P_C , while the pressure on the opposite "side" ($\theta = \pi$) is nearly P_S . Thus the circumferential pressure profile possesses all states between $P_{in} > P_C$ at $\theta = 0$ to approximately $P_S < P_C$ at $\theta = \pi$. Furthermore the system backpressure could be increased above P_C , demonstrating yet another nested distribution - now in both θ and Z (Fig. 3(c)). To corroborate these results, the tests were repeated (e.g., Fig. 3(d)). Thus with eccentric seals pressure gradients of sufficient magnitude can exist to nest two-phase zones both axially and circumferentially.

Bearings

Unlike those for a seal the axial pressure gradients for a bearing are usually small, but the

circumferential gradients are usually much larger.⁵ With the establishment of nested zones in seal flows, such nested zones should occur naturally in bearings. The two-phase zone downstream of the minimum clearance in a bearing is well known, and the pressure and temperature on the stator have been mapped for a low-performance machine (12). It is also noted in (12) that the two-phase zone began to collapse as system ambient pressure was increased. However, calculations (13) for a similar high-performance bearing in fluid hydrogen at high eccentricity (Table 1) reveal a two-phase zone nested within a system where $P_{in} > P_e > P_c$ (Fig. 4). Nested two-phase zones in a bearing can lead to the onset of instabilities, contrary to the axial flow seal. The onset of the nested zone depends on the bearing parameter,⁶ but onset is prevalent at lower ambient pressure (e.g., one-tenth those of Table 1), high eccentricity, and high rotating speed and for large geometries. This effect remains to be verified. If it is correct, this demonstrates yet another method of achieving nested two-phase zones, those not requiring a sharp geometrical configuration to "trigger" the event, spontaneous nucleation within the metastable field being necessary and sufficient.

SUMMARY

Zones of two-phase flows have been shown to be nested within a supercritical pressure envelope. These zones are established by controlling inlet stagnation conditions, exit backpressure, or combinations. The zones can be "triggered" by discontinuous changes in geometry or by significant pressure gradients. For high-performance turbomachine seals and possibly bearings, nested two-phase zones can be found in the circumferential and axial coordinates. The phenomenon in bearings remains to be demonstrated experimentally.

REFERENCES

1. Skripov, V.P., Metastable Liquids, Wiley, New York, 1974.
2. Frenkel, J., Kinetic Theory of Liquids, Dover Publications, New York, 1955.
3. Hendricks, R.C., Mullen, R.L., and Braun, M.J., "Analogy Between Cavitation and Fracture Mechanics," ASME/JSME Thermal Engineering Conference, Proceedings, Vol. 1, ASME, New York, 1983, pp. 35-42.

⁵Both seals and bearings can be designed to take advantage of these pressure gradients to provide significant damping and stiffness, which enhances stability (11).

⁶Modified bearing parameter = $(6\eta R_w / \Delta P C_e)(e/C)$

4. Angus, S., Imperial College, London, private communication.
5. Hendricks, R.C., and Simoneau, R.J., "Some Flow Phenomena in a Constant Area Duct with a Borda Type Inlet Including the Critical Region," ASME Paper 78-WA/HT-37, Dec. 1978.
6. Hendricks, R.C., "Some Observations of a Free Jet Phenomenon in a 90-Degree-Sharp-Edge-Inlet Geometry," Advances in Cryogenic Engineering, Vol. 25, Plenum Press, New York, 1980, pp. 506-520.
7. Hendricks, R.C., "Some Aspects of a Free Jet Phenomenon to 105 L/D in a Constant Area Duct," International Congress of Refrigeration, 15th, Vol. 2, Organizing and Scientific Committee of the 15th International Congress of Refrigeration, Italy, 1980, Paper B1-78.
8. Hendricks, R.C., "A Comparison of Flow Rates and Pressure Profiles for N-Sequential Inlets and Three Related Seal Configurations," Advances in Cryogenic Engineering, Vol. 30, Plenum Press, New York, 1983, pp. 837-846.
9. Hendricks, R.C., and Stetz, T.T., "Flow Rates and Pressure Profiles for One to Four Axially Aligned Borda Inlets," NASA TP-2390, 1984.
10. Hendricks, R. C., "A Comparative Evaluation of Three Shaft Seals Proposed for High Performance Turbomachinery," NASA TM-83021, 1982.
11. Childs, D.W., Hendricks, R.C., and Vance, J.M., eds.: Rotordynamic Instability Problems in High-Performance Turbomachinery, NASA CP-2133, 1980.
12. Braun, M.J., and Hendricks, R.C., "An Experimental Investigation of Vaporous/Gaseous Cavity Characteristics of an Eccentric Journal Bearing," ASLE Transactions, Vol. 27, No. 1, Jan. 1984, pp. 1-14.
13. Braun, M.J., and Hendricks, R.C., "An Experimental Investigation of the Effect of Pressure and Temperature Levels on the Development and Nature of the Cavitation Region in a Submerged Journal Bearing," Cavitation and Multiphase Flow Forum, ASME, New York, 1983, pp. 69-71.
14. Hendricks, R.C., and Stetz, T.T., "Flow Through Aligned Sequential Orifice-Type Inlets," NASA TP-1967, 1982.

TABLE 1. BEARING PARAMETERS FOR ANALYTICAL SOLUTIONS

Geometry:	
Diameter, mm (in.)	25.4 (1)
Length, mm (in.)	25.4 (1)
Clearance, mm (in.)	0.0254 (0.001)
Eccentricity	0.97
Hydrodynamic:	
Inlet pressure, P_{in} , MPa (psia)	13.8 (2000)
Exit pressure, P_e , MPa (psia)	13.45 (1950)
Maximum pressure, P_{max} , MPa (psia)	27.16 (3938)
Minimum pressure, P_{min} , MPa (psia)	0.079 (11.5)
Inlet temperature, T_{in} , K ($^{\circ}$ R)	20 (36)
Speed, rad/sec (rpm)	7850 (75 000)

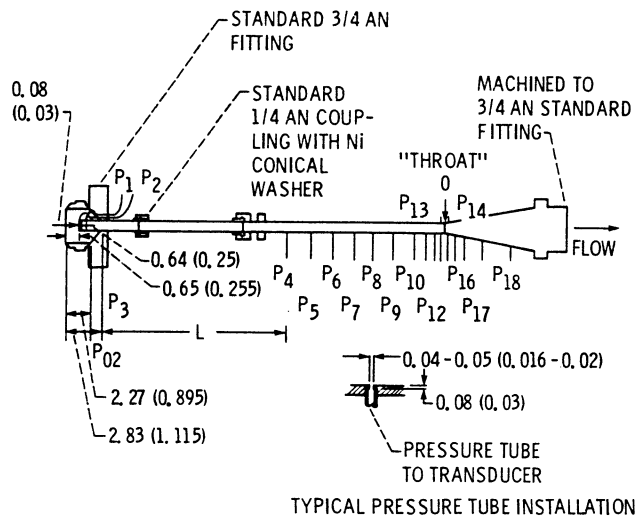
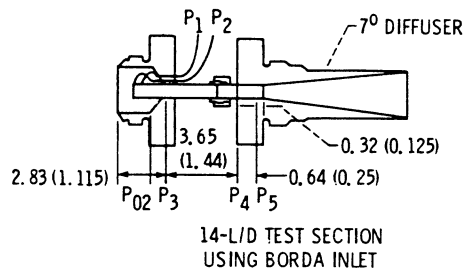

(a) Configuration geometry.

Figure 1. - Pressure profile for nitrogen flow through high-L/D tube with Borda inlet. (Dimensions are in centimeters (inches).)

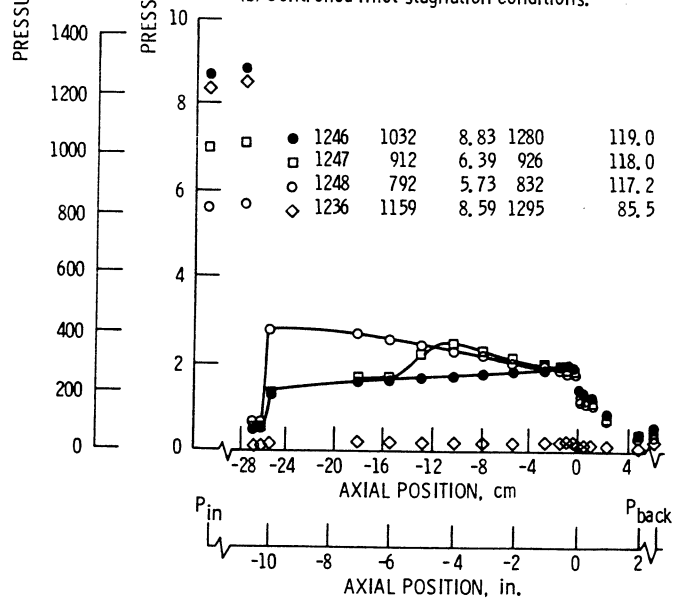
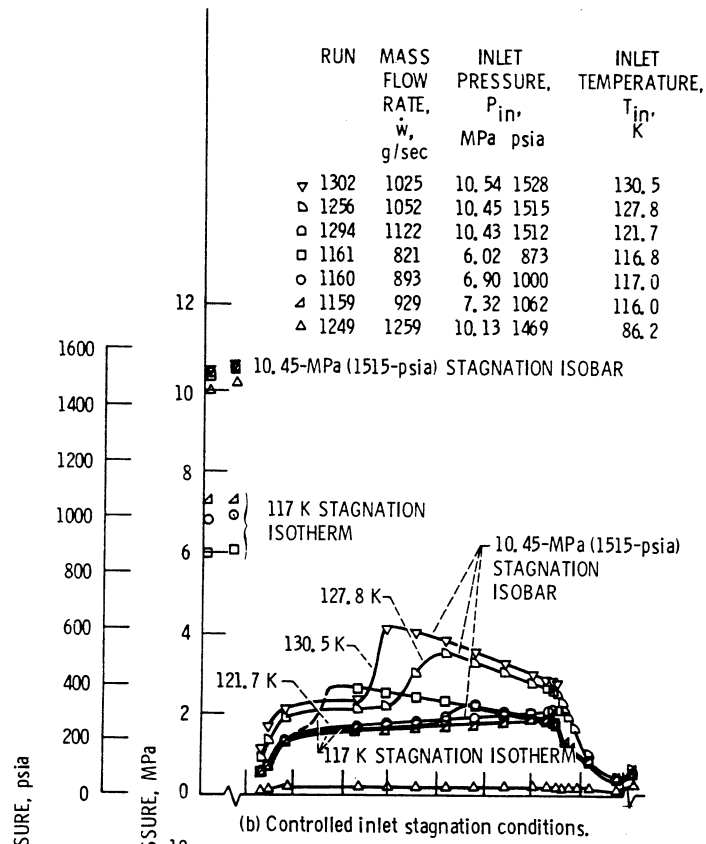
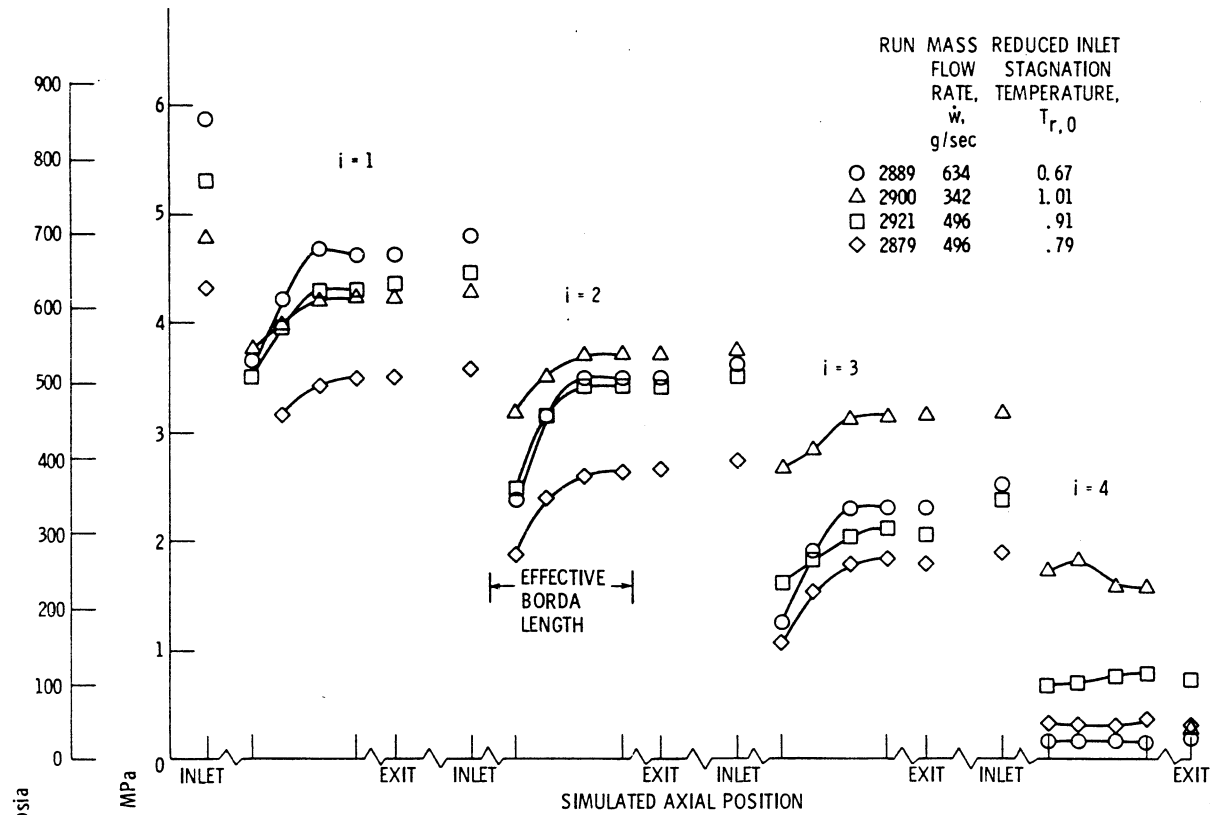
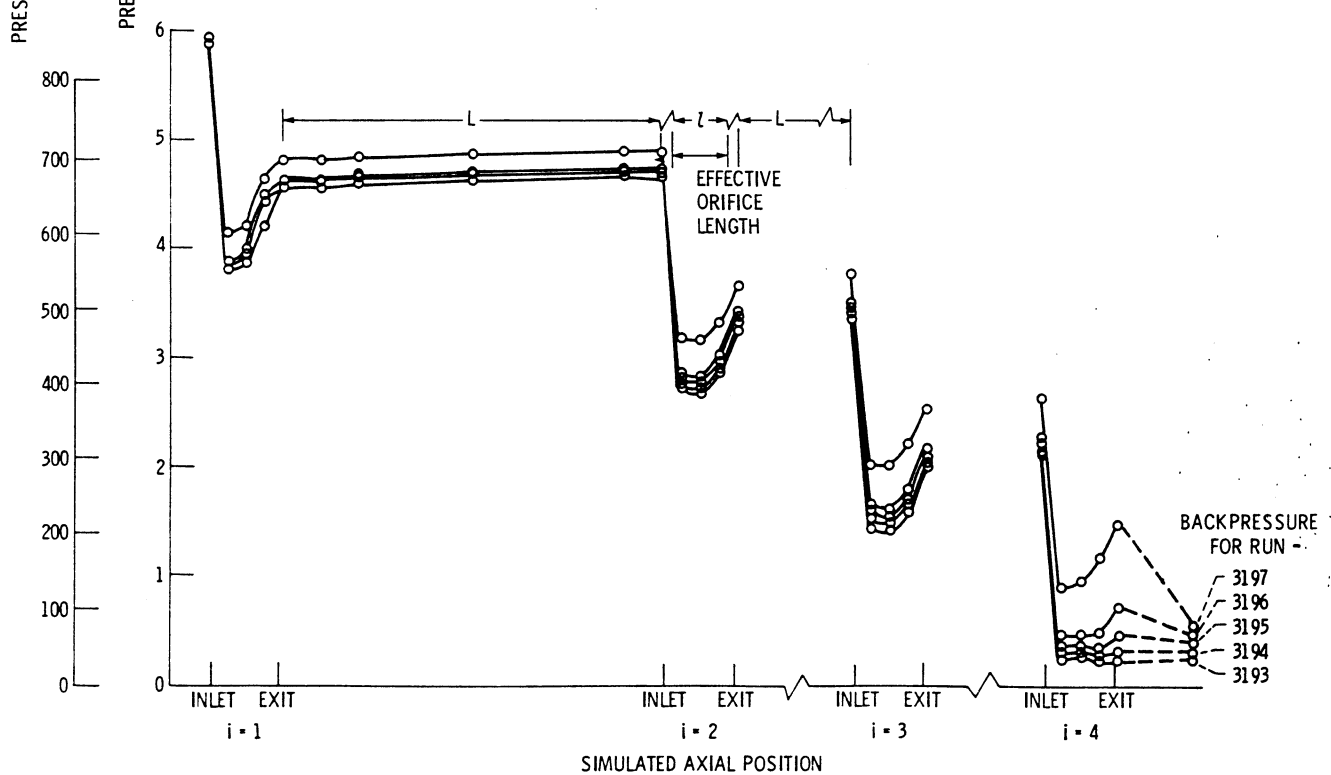

Figure 1. - Concluded.



(a) Controlled inlet stagnation conditions, Borda inlets.



(b) Controlled backpressure, orifice inlets (14).

Figure 2. - Pressure profile for flow through four sequential axially aligned inlets.

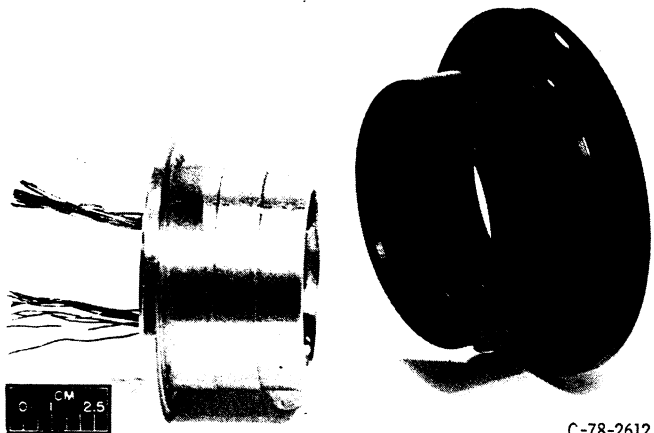
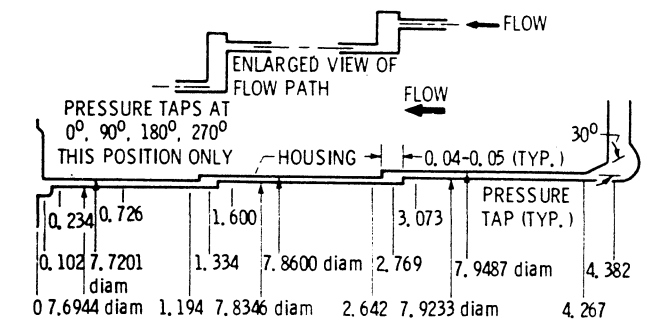

(a) Three-step shaft seal.

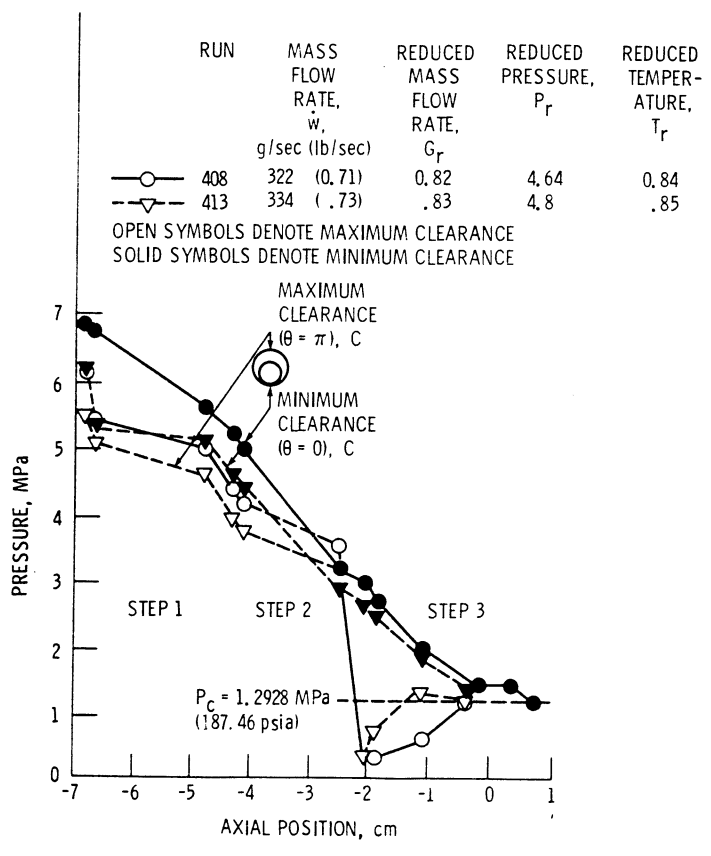

(b) Applied backpressure.

Figure 3 - Pressure profile for fully eccentric, nonrotating, three-step SSME seal configuration.

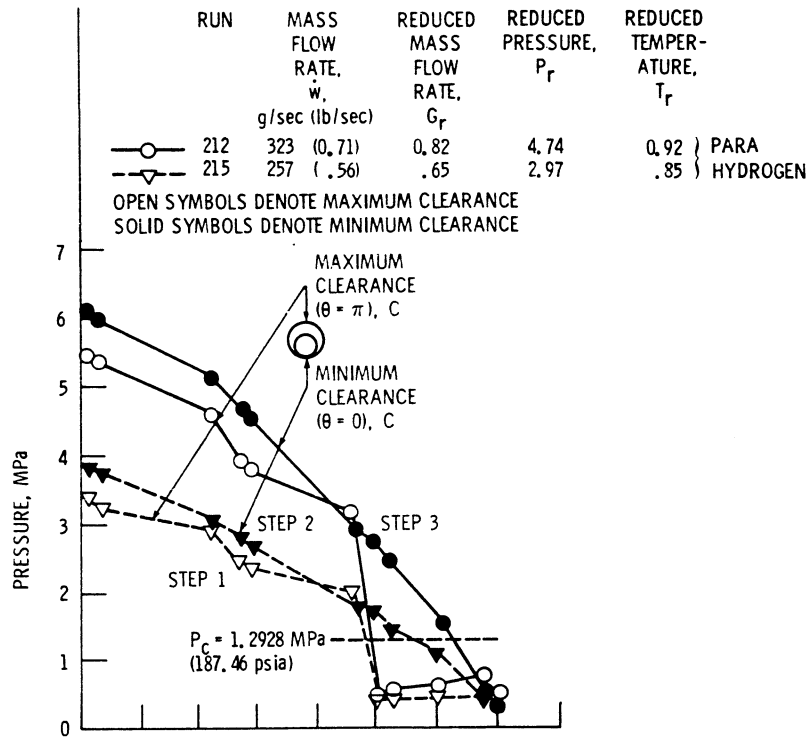

(c) Controlled inlet stagnation conditions.

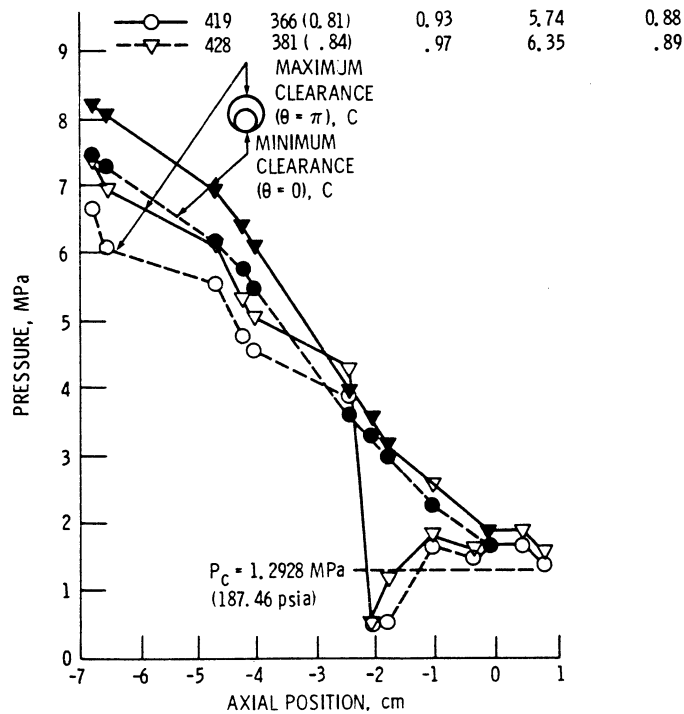

(d) Backpressure control, repeated.

Figure 3. - Concluded.

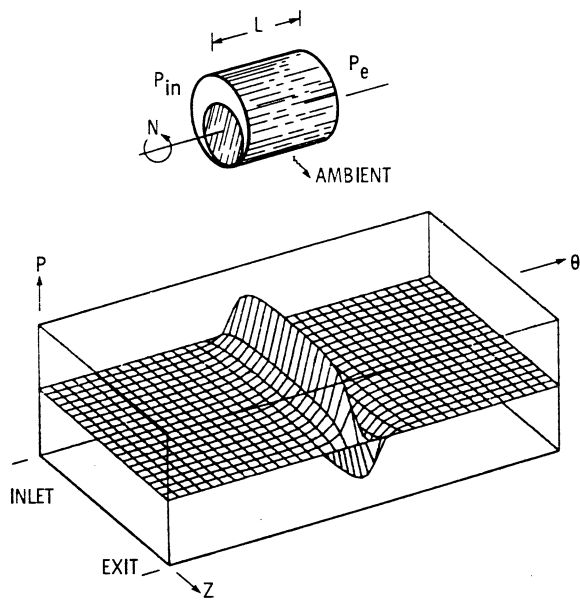

Figure 4. - Analytical pressure map for high-speed journal bearing with $P_{in} > P_e > P_c$. $P_{in} = 13.8$ MPa (2000 psi); $P_e = 13.45$ MPa (1950 psi); $N = 75000$ rpm; $e_x = e_y = 0.68$; $T_{in} = 20$ K (36 °R); $P_{amb} = 0.1$ MPa (14.7 psi); $T_{amb} = 56$ K (100 °R).

1. Report No. NASA TM-86980		2. Government Accession No.		3. Recipient's Catalog No.	
4. Title and Subtitle Nested Subcritical Flows Within Supercritical Systems				5. Report Date	
				6. Performing Organization Code 506-60-42	
7. Author(s) R.C. Hendricks, M.J. Braun, R.L. Wheeler III, and R.L. Mullen				8. Performing Organization Report No. E-2518	
				10. Work Unit No.	
9. Performing Organization Name and Address National Aeronautics and Space Administration Lewis Research Center Cleveland, Ohio 44135				11. Contract or Grant No.	
				13. Type of Report and Period Covered Technical Memorandum	
12. Sponsoring Agency Name and Address National Aeronautics and Space Administration Washington, D.C. 20546				14. Sponsoring Agency Code	
15. Supplementary Notes R.C. Hendricks, NASA Lewis Research Center; M.J. Braun and R.L. Wheeler III, University of Akron, Akron, Ohio 44325; R.L. Mullen, Case Western Reserve University, Cleveland, Ohio 44106. Prepared for the 20th Annual Cavitation and Multiphase Flow Forum sponsored by the American Society of Mechanical Engineers, Albuquerque, New Mexico, June 24-26, 1985.					
16. Abstract In supercritical systems the design inlet and outlet pressures are maintained above the thermodynamic critical pressure P_c . Designers rely on this simple rule of thumb to circumvent problems associated with a subcritical pressure regime nested within the supercritical pressure system along with the uncertainties in heat transfer, fluid mechanics, and thermophysical property variations. The simple rule of thumb is adequate in many low-power designs but is inadequate for high-performance turbomachines and linear systems, where nested two-phase regions can exist. Examples for a free-jet expansion with backpressure greater than P_c and a rotor (bearing) with ambient pressure greater than P_c illustrate the existence of subcritical pressure regimes nested within supercritical systems.					
17. Key Words (Suggested by Author(s)) Two phase; Supercritical; Subcritical; Flows; Cryogenics			18. Distribution Statement Unclassified - unlimited STAR Category 34		
19. Security Classif. (of this report) Unclassified		20. Security Classif. (of this page) Unclassified		21. No. of pages	22. Price*