

NASA Technical Memorandum 86991

Frictional and Structural Characterization of Ion-Nitrided Low and High Chromium Steels

(NASA TM-86991) FRICTIONAL AND STRUCTURAL
CHARACTERIZATION OF ION-NITRIDED LOW AND
HIGH CHROMIUM STEELS (NASA) 17 p
HC A02/MF A01

N85-23385

CSCI 13I

Unclass

G3/37 14711

Talivaldis Spalvins
Lewis Research Center
Cleveland, Ohio



Prepared for the
12th International Conference on Metallurgical Coatings
sponsored by the American Vacuum Society
Los Angeles, California, April 15-19, 1985

NASA

FRictionAL AND STRUCTURAL CHARACTERIZATION OF ION-NITRIDED LOW
AND HIGH CHROMIUM STEELS

Talivaldis Spalvins
National Aeronautics and Space Administration
Lewis Research Center
Cleveland, Ohio 44135

ABSTRACT

Low Cr steels AISI 4140, AISI 4340, and high Cr austenitic stainless steels AISI 304, AISI 316 were ion nitrided in a dc glow discharge plasma consisting of a 75 percent H₂ - 25 percent N₂ mixture. Surface compound layer phases were identified, and compound layer microhardness and diffusion zone microhardness profiles were established. Distinct differences in surface compound layer hardness and diffusion zone profiles were determined between the low and high Cr alloy steels. The high Cr stainless steels after ion nitriding displayed a hard compound layer and an abrupt diffusion zone. The compound layers of the high Cr stainless steels had a columnar structure which accounts for brittleness when layers are exposed to contact stresses. The ion nitrided surfaces of high and low Cr steels displayed a low coefficient of friction with respect to the untreated surfaces when examined in a pin and disk tribotester.

INTRODUCTION

Ion nitriding is a glow discharge surface and subsurface modification technique to increase surface hardness and to improve wear resistance primarily for ferrous alloy steel mechanical components. When two surfaces are brought together in relative motion, compressive stresses and shear forces are developed in the contacting asperities. Because of the asperities small dimensions they rapidly undergo plastic deformation, thus increasing the true area of contact. The compressive stresses involved in contact not only modify the surface layers but also affect the subsurface layers. The surface and subsurface resistance to deformation can be improved by ion nitriding, which

results in the formation of a surface compound layer and a subsurface diffusion zone, both exerting a hardening effect.

To obtain the best response to nitriding, the nitridable steels should contain alloying elements that have a high affinity for nitrogen such as Al, Cr, Mo, V, Ti. Unalloyed carbon steels are not well suited for nitriding since they form an extremely brittle case that spalls readily while in service. The hardness and hardenability of the steels is induced by nitrogen diffusion into and reaction with the steel. As the concentration of the diffused nitrogen increases, the solubility limits are exceeded and various second phases precipitate. Initially these precipitates, complex nitride phases, are very finely divided and dispersed, but eventually the concentration of the diffusing nitrogen builds to such a concentration that a continuous layer of second phase is formed at the surface. The surface compound layer is believed to be formed when the nitriding potential of the gas mixture is such that the concentration (activity) of nitrogen in iron exceeds that in equilibrium with the iron nitrides (Fe_4N or Fe_{2-3}N). These compound layer phases consist predominantly of Fe_4N or Fe_{2-3}N or their mixtures. All nitridable steels are hardened by both the compound layer and nitrogen solubility-diffusion zone (Refs. 1 to 3). The properties of the surface or compound layer and subsurface diffusion zone are highly affected by the type and concentration of the alloying element in the steel during the nitriding process.

The objective of this investigation was to nitride the low Cr alloy steels AISI 4140, AISI 4340, and high Cr stainless steels AISI 304, AISI 316, and compare the effects of Cr on the formation of the compound layer and the nitrogen solubility-diffusion zone. This was done by taking microhardness surface and subsurface profile measurements and scanning electron and optical micrographs. The friction characteristics of these materials were also determined using a pin and disk tribotester.

EXPERIMENTAL CONDITIONS

Ion Nitriding

The ion-nitriding apparatus is shown photographically in Fig. 1(a) and schematically in Fig. 1(b). The system consists of a glass cylinder 45 cm in diameter placed on a steel feed-through ring, with a removable aluminum cover lid. The nitriding steel specimen is the cathode and the steel base plate mounted on ceramic insulators is the anode. The temperature of the specimen is measured with a chromel-alumel thermocouple embedded in the specimen in a perpendicular position, near the surface.

The nitriding gas was a preset mixture of 75 percent H_2 - 25 percent N_2 which was directly fed from a bottle to the chamber through a variable leak control valve. The discharge pressure used for this treatment was 3 to 4 torr, the applied dc voltage 450 to 600 V, and the current density on the nitriding sample was 3.4 to 4 mA/cm².

Before ion nitriding, the steel specimens were argon dc-sputter etched for 20 min. After sputter-cleaning the voltage applied to the specimens ionizes the gas mixture causing N^+ ions to accelerate toward and bombard the negatively charged specimen, thus generating heat and introducing a chemical change.

Specimens

In this investigation low Cr alloy steels such as AISI 4140, 4340, and high Cr austenitic stainless steels such as AISI 304 and 316 were ion nitrided. The compositional analysis of the steels used in this investigation fall within the normally reported composition range as shown in Table I. The specimens were disks 6.3 cm in diameter by 0.25 cm thick and the surfaces were finished on a 600 grit SiC paper and finally rinsed with acetone and absolute ethyl alcohol before ion nitriding.

Testing

The surface topography and the cross sections of the ion nitrided case were investigated by scanning electron microscopy (SEM) and optical microscopy. Surface hardness and subsurface hardness profiles were established by Vickers microhardness testing. The frictional characteristics were evaluated in a pin and disk tribotester at constant sliding speed of 1.52 m/min^{-1} , and normal load of 2.45 N under vacuum (2×10^{-3} torr).

POSSIBLE ION NITRIDING REACTIONS

The elementary reactions and mechanisms for dc glow discharge nitriding have been of major interest, since diverse experiments have led to several contradictory interpretations concerning the nitriding mechanism (Refs. 4 to 7). The Kolbel's hypothesis (Ref. 6) has been the most widely accepted one and is schematically shown in Fig. 2. This hypothesis is attributed to a mechanism in which the sputtered iron atoms from the specimen combine with the active nitrogen in the plasma and form a molecularly unstable compound, FeN, which is then backscattered and condenses on the specimen. In a gas pressure of 1 torr, sputtered material will be backscattered by collisions and redeposited on the specimen. The condensed FeN is metastable on the surface at the ion nitriding temperatures (350 to 600 °C) it dissociates and releases atomic nitrogen, either by diffusing into the lattice and forms lower nitrides (Fe_2N , Fe_3N , and Fe_4N), or it desorbs from the surface and combines to form molecular nitrogen. The hardness is imparted by combination of the nitrogen with the alloying elements present in the steels. The salient features of this hypothesis are sputtering and the formation of metastable FeN.

RESULTS AND DISCUSSION

Microhardness Profiles

All surface and subsurface microhardness measurements were made with a Vickers diamond indenter using a 50 gm load at approximately 20 μm intervals

across a cross section of the specimen. Typical hardness profiles for the low Cr alloy steels 4140 and 4340 and high Cr stainless steels 304 and 316 ion nitrided at 550 °C for 6 hr are presented in Fig. 3. Two distinct differences are observed between the low and high Cr steels in terms of surface hardness and hardenability. The low Cr steels display a lower surface hardness (780 kg/mm²) relative to the high Cr steels which have a higher surface hardness (900 to 1000 kg/mm²) and secondly, the low Cr steels have an extended diffusion zone of over 350 μm, whereas the high Cr stainless steels displayed an abrupt diffusion zone.

Stainless steels with high Cr concentration are strong nitride formers and strong bonds are formed between Cr and N. Due to the high reactivity between Cr and N, increasingly rich nitride phases are precipitated, thus hindering the nitrogen migration from further diffusion. This suggests that the interstitial nitrogen atoms are being prevented from diffusing further away from the highly concentrated nitride regions. The nitrogen immobility is believed to be responsible for the formation of the very shallow diffusion zone. The solubility of nitrogen in austenitic steels such as 304 and 316 is ~1 at %. Above this level nitrogen must occur in a combined state as Fe or Cr nitrides. It should be also noted, that the published hardness value of CrN is H_V 1100 (Ref. 8). This value is complementary with the surface hardness values obtained in this investigation.

The maximum N concentration on the surface for ion nitrided 316 steel has been reported to be 14 at % as analyzed by nuclear microprobe analysis and shown in Fig. 4 (Ref. 9). The N concentration falls approximately exponentially from 14 at % at the surface to 9 at %, followed by a sharp drop to the core level of the unreacted steel.

Basically, the higher the Cr alloy content of the steel the narrower is the nitrided diffusion zone obtained with equal time at the same nitriding

temperature. Figure 5 schematically illustrates the ion nitriding variables which affect the hardness and hardenability of the steel. The sharp interface for 304 stainless steels has been also reported by several investigators (Refs. 9 and 10) who also indicated that steels containing more than 5 wt % Cr should generate an abrupt interface and a shallow diffusion zone.

Microstructure

The white surface compound layer for 4140 steel ion nitrided at 500 °C for 6 hr was identified by x-ray diffractometry as $\gamma\text{-Fe}_4\text{N}$ single phase with some residual $\epsilon\text{-(Fe}_3\text{N-Fe}_2\text{N)}$ phase present. The corresponding diffractogram for the untreated and ion nitrided steel is shown in Fig. 6. A slight carbon contamination in the system is responsible for the formation of the ϵ -phase. The $\gamma\text{-Fe}_4\text{N}$ is a monophasic and is formed between 19 to 21 at % N and has an FCC structure. A typical microstructure of 4340 steel with the white compound layer after etching with 1% nital is shown in Fig. 6. It should be noted, that the low Cr steels such as 4340 display a gradual transition region between the case and the core.

The austenitic stainless steels 304 and 316 because of their high Cr content form very abrupt interfaces during ion nitriding and as a result a distinct, weak boundary or separation exists between the core and the case. This sharp separation between the phases has a distinct porous boundary as shown from the surface in Fig. 8(a) and in cross section in Fig. 8(b) for the 304 stainless steel. It is interesting to note, that the compound layers for 304 and 316 also have the typical columnar type of structure. This can be observed after fracturing the compound layer as shown in Fig. 9.

Friction Results

Friction experiments were conducted on the low and high Cr nitrided disk surfaces with an ion nitrided 440C rider. The hardness of the untreated 440C rider was HRC 52. The thickness of the compound layer on the steel surfaces

used for friction tests was below 2 μm . The friction results are tabulated in Fig. 10. The ion nitrided surfaces gave the lowest coefficients of friction relative to the untreated surface. In addition a small difference in the coefficient of friction was observed between the low and high Cr steel surfaces 0.13 to 0.12, respectively. The average steady state wear rate after 4000 cycles was $12 \times 10^{-15} \text{ m}^3/\text{m}$ for the $\gamma\text{-Fe}_4\text{N}$ phase.

The compound layer during dry sliding provides excellent adhesive or scuffing resistance as compared to the diffusion zone which has only a limited adhesive resistance. Therefore, the predominant wear mechanism for ion nitrided surfaces is abrasive.

SUMMARIZING REMARKS

The following conclusions are drawn between the ion nitrided low and high Cr steels:

1. The high Cr austenitic steels (304, 316) display a higher surface hardness of the compound layer and an abrupt diffusion zone.
2. The low Cr steels (4140, 4340) display a lower surface hardness and an extended diffusion zone.
3. The compound layer for the high Cr steels has a columnar structure which is very fragile.
4. The ion nitrided steels displayed a significant reduction in the coefficient of friction. The high Cr steels produced the lowest coefficients of friction.

REFERENCES

1. C.V. Robino; and O.T. Inal, Mater. Sci. Eng., 1983, 59, 79-90.
2. P.C. Jindal, J. Vac. Sci. Technol., 1978, 15, 313-317.
3. A.M. Staines; and T. Bell, Thin Solid Films, 1981, 86, 201-211.
4. Martin Hudis, J. Appl. Phys., 1973, 44, 1489-1496.

5. Gary G. Tibbets, J. Appl. Phys., 1974, 45, 5072-5073.
6. D.J. Sturges; and D.J. Shade, West Lynn, MA, Nov. 1975, General Electric Report No. DF75MSD324.
7. H. Brokman; F. Dothan; and F. Tuler, Mater. Sci. Eng., 1979, 40, 261-263.
8. G.V. Samsonov; and I.M. Vinitskii, "Handbook of Refractory Compounds," IFI/PLENUM, New York, 1980.
9. M.P. Hill; and K.S. Pankhurst, Surf. Technol., 1979, 8, 253-262.
10. B.J. Lightfoot and D.H. Jack, in "Source Book on Nitriding," American Society for Metals, Metals Park, OH, 1977.
11. A. Brokman; F. Dothan; and F. Tuler, Mater. Sci. Eng., 1979, 40, 261-263.

TABLE I. - CHEMICAL COMPOSITION OF STEELS

	AISI 4140	AISI 4340	AISI 304	AISI 316
C	0.38	0.38	0.08	0.06
Mn	.75	.70	2.00	1.8
P	.40	-----	0.045	0.02
Si	.40	-----	1	.5
Ni	-----	1.65-2.00	9	11.8
Cr	0.8-1.10	1.70-0.90	19	17.7
Mo	0.15- .25	0.20-0.30	-----	2.7

ORIGINAL PAGE IS
OF POOR QUALITY

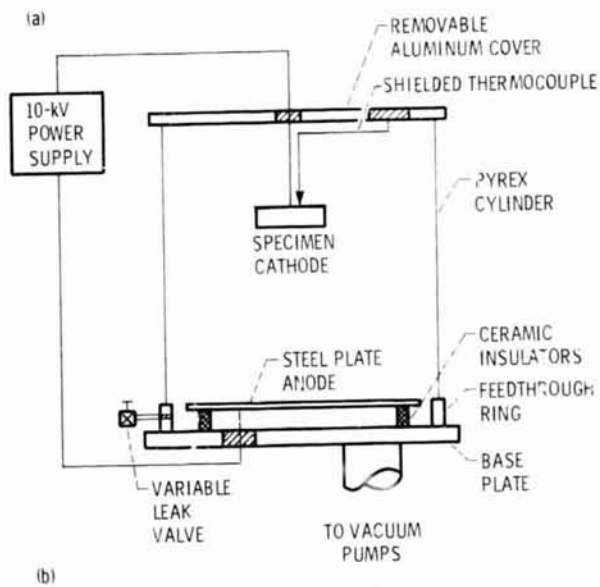
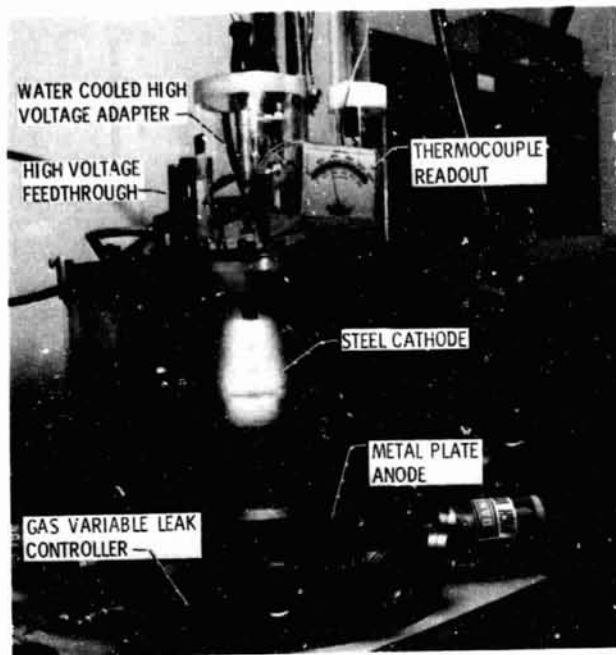

(a) Ion nitriding chamber.
(b) Schematic of ion nitriding apparatus.

Figure 1. - Ion nitriding system.

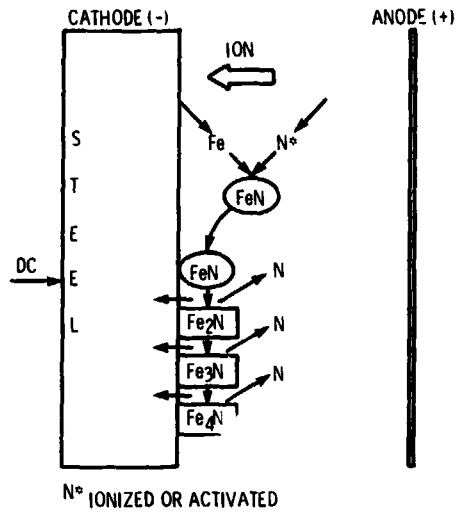

Figure 2. - Glow discharge ion nitriding mechanism.

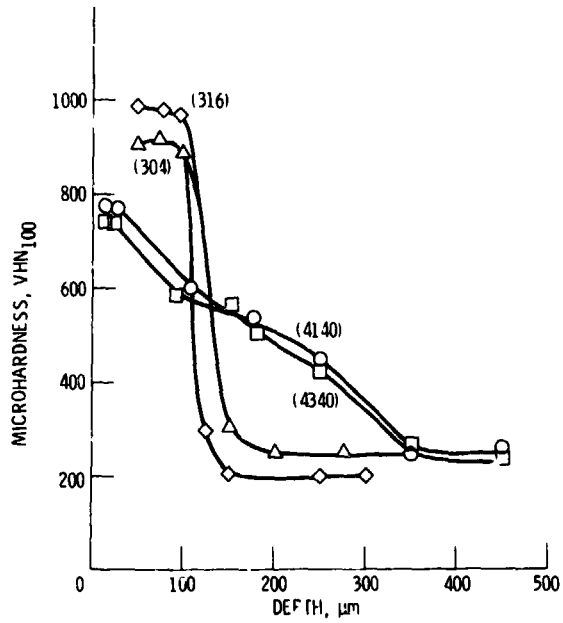

Figure 3. - Microhardness profiles of ion nitrided steels: 4140, 4340, 316, and 304.

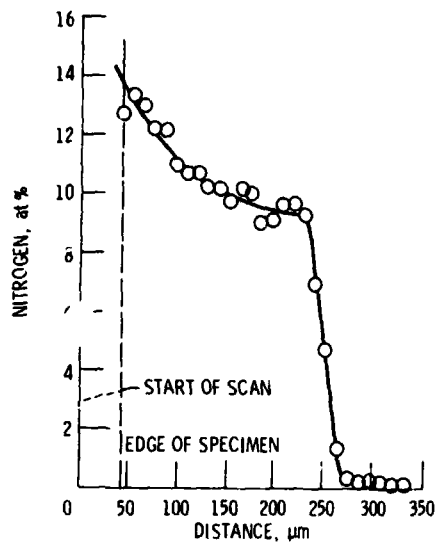

Figure 4 - Nitrogen concentration profile by nuclear microprobe analysis. (Ref. 9.)

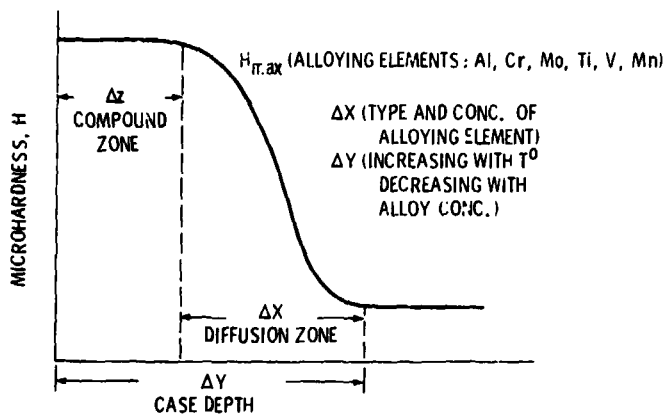

Figure 5 - Ion nitriding effects on microhardness profile and case depth.

ORIGINAL PAGE IS
OF POOR QUALITY

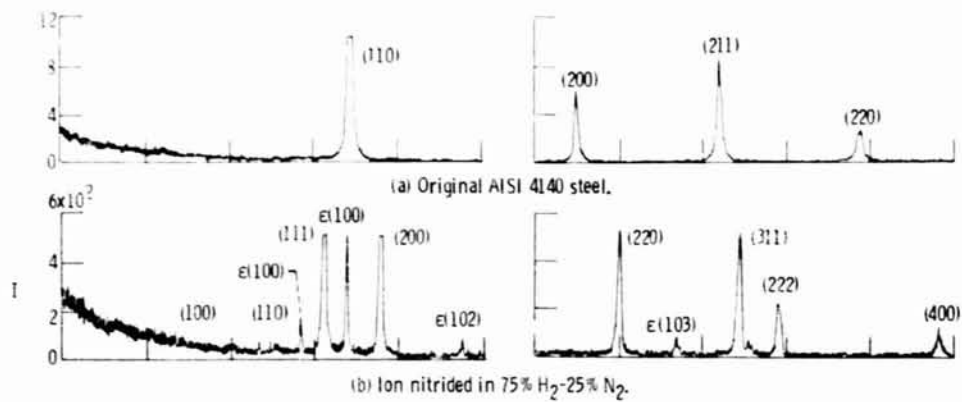

Figure 6. - X-ray diffractograms of ion nitrided AISI 4140 steel.

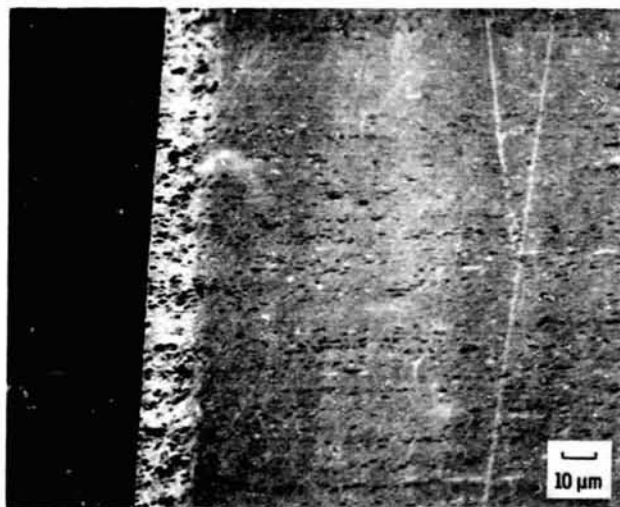

Figure 7. - SEM cross section of ion nitrided 4340 steel at 500 °C for 6 hours.

ORIGINAL PAGE IS
OF POOR QUALITY

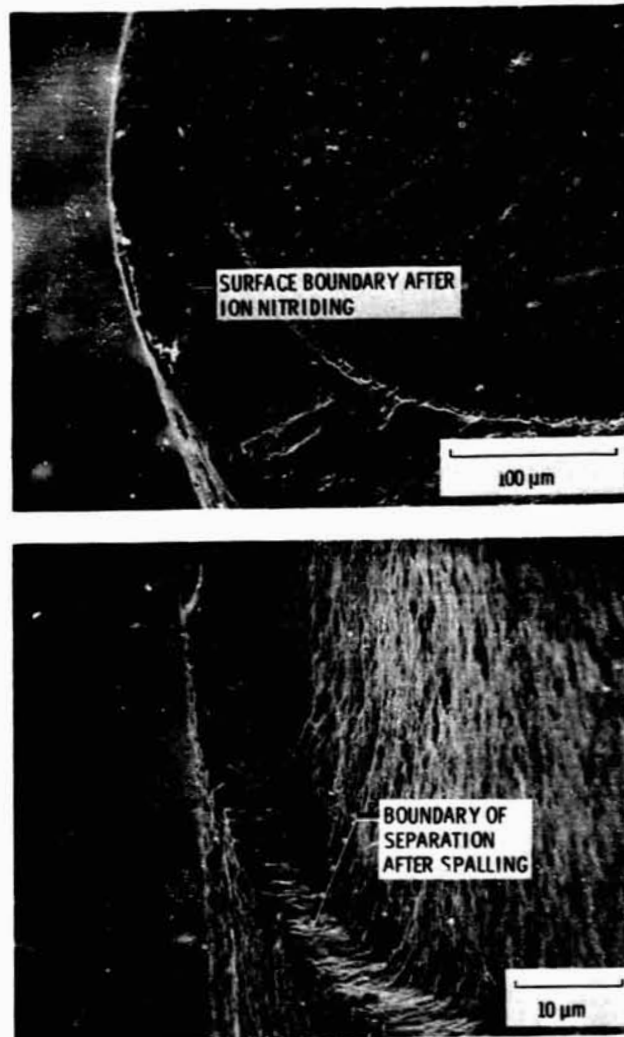

Figure 8. - SEM surface views of ion nitrided 304 stainless steel with distinct boundary of separation.

ORIGINAL PAGE IS
OF POOR QUALITY

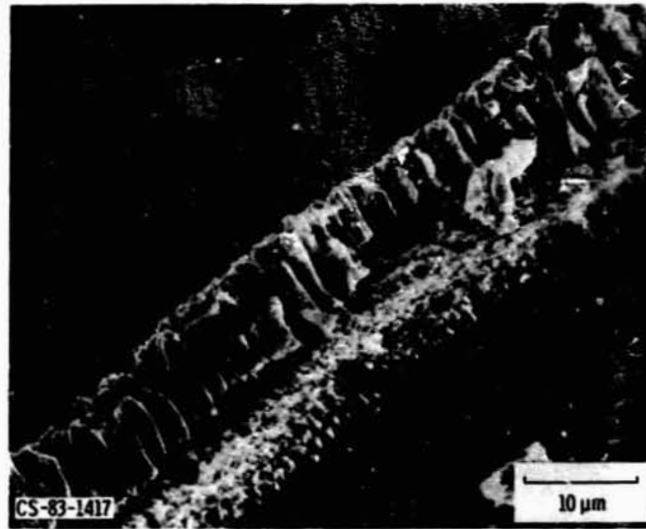

Figure 9. - SEM surface view of ion nitrided 304 stainless steel after fracture.

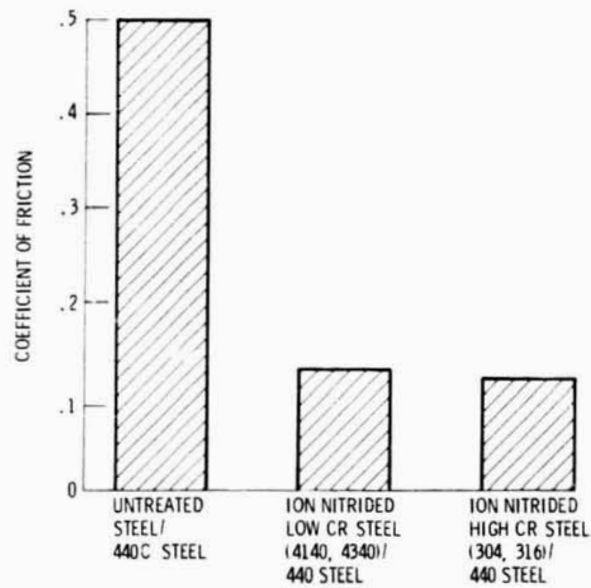

Figure 10. - Coefficient of friction for untreated steels and ion nitrided steels.