

NASA-TM-86215 19850018541

NASA Technical Memorandum 86215

Space Station Spartan Study Final Report

John H. Lane, Joseph R. Schulman,
Werner M. Neupert, et al.

JULY 1985

LIBRARY COPY

AUG 10 1985

LANGLEY RESEARCH CENTER
LIBRARY, NASA
HAMPTON, VIRGINIA

NASA



NASA Technical Memorandum 86215

Space Station Spartan Study Final Report

John H. Lane, Joseph R. Schulman,
Werner M. Neupert, et al.
*Goddard Space Flight Center
Greenbelt, Maryland*

NASA
National Aeronautics
and Space Administration
**Scientific and Technical
Information Branch**

1985

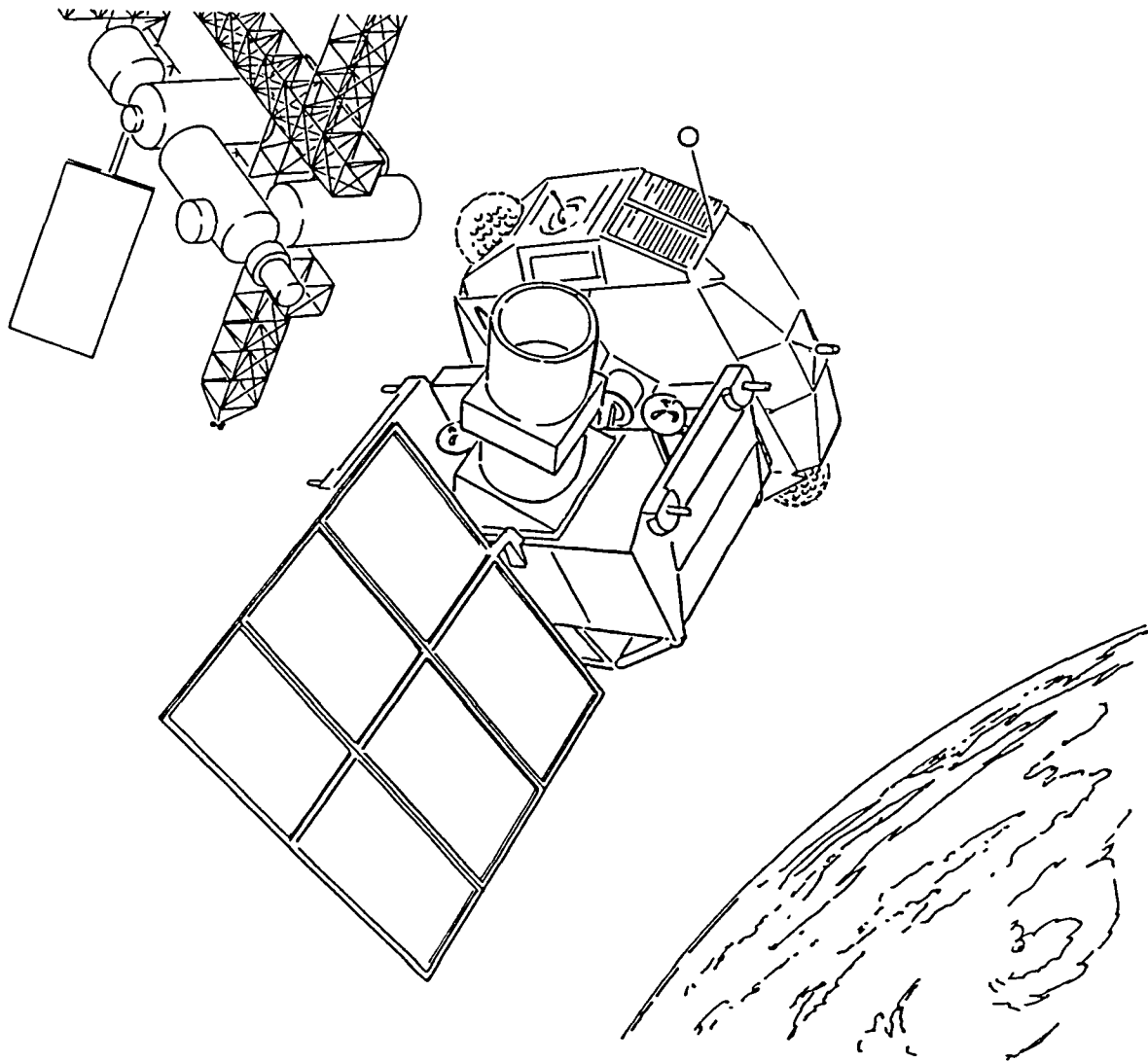

Frontispiece. Space Station Spartan and Orbital
Maneuvering Vehicle Near Space Station

CONTENTS

<u>Para.</u>		<u>Page</u>
1.	INTRODUCTION	1-1
1.1	BACKGROUND	1-6
1.2	SPACE STATION SPARTAN HISTORY TO DATE	1-7
1.3	POTENTIAL BENEFITS OF A SPACE STATION SPARTAN PROGRAM	1-7
1.4	SPACE STATION SPARTAN STUDY	1-8
2.	SUMMARY	2-1
2.1	SPACE STATION SPARTAN SYSTEM	2-1
2.2	SUMMARY OF SPACE STATION ACCOMMODATION REQUIREMENTS FOR SPACE STATION SPARTAN	2-8
2.2.1	Mobile Remote Manipulator System	2-9
2.2.2	Extravehicular Activity	2-9
2.2.3	Orbital Maneuvering Vehicle	2-10
2.2.4	Spacecraft Service Area	2-10
2.2.5	Storage Bay	2-10
2.2.6	Spacecraft Refueling Area	2-11
2.2.7	Other Space Station Requirements for Space Station Spartan	2-11
2.3	SPACE STATION SPARTAN STUDY CONCLUSIONS AND RECOMMENDATIONS	2-12
2.3.1	Carrier Capabilities	2-12
2.3.2	Space Station Spartan Design Concepts	2-13
2.3.3	Propulsion	2-13
2.3.4	Structural Subsystem	2-14
2.3.5	Power, Command and Data Handling, and Communications	2-14
2.3.6	Mission Scenario	2-14
2.3.7	General	2-15
3.	SPACE STATION SPARTAN SYSTEM DESCRIPTION	3-1
3.1	SPACE STATION SPARTAN PHYSICAL DESCRIPTION	3-1
3.1.1	Carrier Structure Subsystem	3-1
3.1.2	Power Subsystem	3-4
3.1.3	Command and Data Handling Subsystem	3-4
3.1.4	Communications Subsystem	3-4
3.1.5	Attitude Control Subsystem	3-5

CONTENTS (Continued)

<u>Para.</u>		<u>Page</u>
3.1.6	Propulsion Subsystem	3-5
3.1.7	Thermal Control Subsystem	3-5
3.1.8	Space Station Spartan Handling Provisions . .	3-5
3.2	SPACE STATION SPARTAN SYSTEM INTERFACES	3-5
3.3	SPACE STATION SPARTAN MISSION SCENARIO - OPERATIONS AT THE SPACE STATION	3-10
3.3.1	3S Mission Scenario and Overview	3-10
3.3.2	Space Station Spartan Mission Scenario - Step By Step Description	3-12
4.	SPACE STATION SPARTAN SCIENCE	4-1
4.1	POTENTIAL USERS OF SPACE STATION SPARTAN	4-1
4.1.1	Potential Users of a Basic Space Station Spartan Attitude Control System	4-1
4.1.2	Potential Users of an Upgraded Space Station Spartan Attitude Control System	4-2
4.1.3	Potential Users of a High Performance Attitude Control System	4-3
4.2	DEVELOPMENT OF STRAWMAN SCIENCE REQUIREMENTS	4-3
4.2.1	Strawman Instrument Descriptions and Requirements	4-4
4.3	SCIENCE OPERATIONS FOR THE STRAWMAN INSTRUMENTS . .	4-5
5.	SPACE STATION SPARTAN SUBSYSTEMS DESCRIPTION	5-1
5.1	SPACE STATION SPARTAN MECHANICAL SUBSYSTEMS	5-1
5.1.1	Space Station Spartan Carrier Structure	5-1
5.1.2	Subsystem Modules	5-5
5.1.3	Solar Array	5-6
5.1.4	Propulsion Subsystem	5-6
5.2	SPACE STATION SPARTAN POWER SUBSYSTEM	5-6
5.2.1	Design Heritage	5-6
5.2.2	Functional Description	5-9
5.2.3	Load Requirements	5-11
5.2.4	Battery Size and Performance	5-11
5.2.5	Solar Array Size and Performance	5-14
5.2.6	Physical Description	5-16

CONTENTS (Continued)

<u>Para.</u>		<u>Page</u>
5.3	SPACE STATION SPARTAN THERMAL CONTROL SUBSYSTEM . . .	5-19
5.4	SPACE STATION SPARTAN COMMAND AND DATA HANDLING SUBSYSTEM	5-20
5.4.1	Introduction	5-20
5.4.2	Functions	5-20
5.5	SPACE STATION SPARTAN COMMUNICATIONS (RF) SUBSYSTEM	5-22
5.6	SPACE STATION SPARTAN ATTITUDE CONTROL SUBSYSTEM . . .	5-27
5.6.1	Introduction	5-27
5.6.2	Performance Requirements and Assumptions . . .	5-27
5.6.3	Design Approach and Rationale	5-29
5.6.4	Disturbance Environment and Component Sizing	5-29
5.6.5	Preliminary Design	5-30
5.6.6	On-Orbit Stationkeeping and Evolutionary Considerations	5-34
5.7	SPACE STATION SPARTAN FLIGHT DYNAMICS	5-35
5.7.1	Introduction	5-35
5.7.2	Deployment	5-35
5.7.3	Stationkeeping	5-38
5.7.4	Retrieval	5-38
5.7.5	Conclusion	5-39
5.8	SPACE STATION SPARTAN PROPULSION SUBSYSTEM	5-39
5.8.1	Propulsion System Requirements	5-39
5.8.2	Propellant Requirements	5-39
5.8.3	System Design	5-42
5.8.4	Cold Gas Versus Hydrazine	5-42
6.	SPACE STATION SPARTAN GROUND SYSTEM	6-1
6.1	GROUND SYSTEM DESCRIPTION	6-1
6.2	SPACE STATION SPARTAN GROUND CONTROL CENTER	6-1
6.3	SPACE STATION SPARTAN INTEGRATION AND TEST	6-1
6.3.1	Ground Integration and Test	6-3
6.3.2	Space Station Integration and Test	6-4
6.3.3	On-orbit Checkout	6-5

CONTENTS (Continued)

<u>Para.</u>		<u>Page</u>
7.	OTHER OPERATIONAL CONSIDERATIONS	7-1
7.1	PRELAUNCH AND STS LAUNCH PHASE OPERATIONS	7-1
	7.1.1 Operations During STS Launch Phase	7-1
7.2	STORAGE AT THE SPACE STATION	7-1
	7.2.1 Thermally Controlled Enclosure	7-1
	7.2.2 Mechanical Interface	7-4
	7.2.3 Electrical Interface	7-4
	7.2.4 Duration	7-4
	7.2.5 Size	7-5
	7.2.6 Weight	7-5
	7.2.7 Power	7-5
	7.2.8 Thermal	7-5
	7.2.9 Telemetry	7-6
7.3	SPACE STATION SPARTAN REPAIR	7-6
	7.3.1 Replacement of Subsystem Modules	7-6
	7.3.2 Repairing an Inoperative Subsystem Module	7-7
	7.3.3 Propulsion Subsystem Replacement	7-7
7.4	SPACE STATION SPARTAN SAFETY	7-8
7.5	SPACE STATION SPARTAN CONTAMINATION CONSIDERATIONS	7-9
	7.5.1 Space Station Spartan Contamination Control Goals	7-9
	7.5.2 Contamination Design, Instrumentation, Analysis, and Procedural Requirements	7-9
	7.5.3 Contamination Considerations Summary	7-11
7.6	SPACE STATION SPARTAN RELIABILITY, MAINTAINABILITY, AND QUALITY	7-11
	7.6.1 Reliability	7-11
	7.6.2 Maintainability	7-12
	7.6.3 Quality	7-12

APPENDIX A--BASIC DEFINITIONS OF THE SPACE STATION
SPARTAN (3S)

APPENDIX B--COMMENTS REGARDING SPACE STATION SPARTAN BY THE
BANKS SUBCOMMITTEE FOR PLATFORMS

CONTENTS (Continued)

<u>Para.</u>	<u>Page</u>
APPENDIX C--SPACE STATION SPARTAN (3S) STUDY	
APPENDIX D--PRELIMINARY TIMELINE FOR 3S OPERATIONS AT SPACE STATION	
APPENDIX E--CONVERSION OF DROP CENTER BOX SFSS TO 3S PRIMARY SUPPORT STRUCTURE	
APPENDIX F--SPACE STATION SPARTAN PAYLOAD HAZARD REPORTS	

ILLUSTRATIONS

<u>Figure</u>		<u>Page</u>
1-1	Spartan Carriers Under Development	1-2
1-2	Mission Scenario for Spartan Operating from STS Orbiter	1-3
1-3	Space Station Spartan, View from Subsystem Module Side	1-4
1-4	Space Station Spartan, View from Solar Array Side	1-5
2-1	Space Station Spartan, Exploded View	2-2
2-2	Space Station Spartan, Orthographic View	2-3
2-3	Space Station Spartan Program Operational Scenario	2-5
2-4	Space Station Spartan Systems, Considered Subsystems, and Operational Modes	2-7
3-1	Space Station Spartan Primary Support Structure with Attachment Points to STS Orbiter	3-3
3-2	Space Station Spartan Telemetry and Command Flow	3-6
3-3	Space Station Spartan Block Diagram	3-8
3-4	Space Station Configuration	3-13
3-5	Shuttle Docks at Space Station	3-14
3-6	RMS Removes 3S from Cargo Bay	3-15
3-7	Midair Handover of 3S from RMS to MRMS	3-17
3-8	MRMS Moves 3S to Service Bay	3-18
3-9	Space Station Crew Member Deploys Solar Array and Removes Louver Covers	3-19
3-10	Crew Member Conducts Visual Inspection of 3S	3-20
3-11	OMV Docks with 3S	3-21
3-12	OMV/3S Deployed by MRMS	3-23

ILLUSTRATIONS (Continued)

<u>Figure</u>		<u>Page</u>
3-13	OMV with 3S Maneuvers Away from Space Station . . .	3-24
3-14	OMV Separates from 3S	3-25
3-15	3S Conducts 3 Month Scientific Mission	3-26
3-16	3S Storage Carrier Arrives at Space Station	3-27
3-17	3S Storage Carrier Installed in Storage Bay	3-29
3-18	OMV Rendezvous with 3S	3-30
3-19	OMV/3S Maneuvers for Capture by MRMS	3-32
3-20	Instrument 1 Removed From 3S Carrier	3-33
3-21	Instrument 2 Removed From 3S Storage Carrier	3-34
3-22	Instrument 2 Installed in 3S Carrier	3-36
3-23	Space Station Crew Member Replaces ACS Module	3-37
3-24	3S Hydrazine Propulsion Subsystem is Refueled	3-39
4-1	Optical System for Hopkins Ultraviolet Telescope Strawman Payload	4-5
4-2	Possible Configuration for Solar Physics Cluster Strawman Payload	4-6
4-3	Typical Target Acquisition Sequence for a 3S Astronomy Payload	4-13
4-4	Automated Target Acquisition Sequence for a 3S Astronomy Payload	4-14
5-1	Spartan Flight Support Structure Proposed for Spartan/STS, Orthographic View	5-2
5-2	3S Science Payload Interface Structure	5-4
5-3	3S Solar Array	5-7
5-4	3S Propulsion Subsystem	5-8
5-5	3S Power Subsystem Diagram	5-10

ILLUSTRATIONS (Continued)

<u>Figure</u>		<u>Page</u>
5-6	Solar Array Configuration During Solar-Pointing Mission (Solar array and Instrument Pointed to the Sun)	5-16
5-7	Solar Array Configuration During Stellar-Pointing Mission	5-17
5-8	3S C&DH Block Diagram	5-24
5-9	System Diagram of 3S Communications System	5-26
5-10	RF Communications Link to 3S	5-28
5-11	Block Diagram of ACS Configuration 1	5-31
5-12	Block Diagram of ACS Configurations 2 and 3	5-31
5-13	Separation Distance Versus Time	5-37
5-14	Maximum IPS Propellant Requirements Scenario	5-41
5-15	Minimum IPS Propellant Requirements Scenario	5-43
5-16	3S Propulsion	5-44
5-17	Baseline 3S Propulsion System	5-45
6-1	Space Station Spartan Ground System	6-2
7-1	Space Station Spartan Prelaunch Operations	7-2
7-2	Space Station Spartan Replacement Instrument Operations	7-3

TABLES

<u>Table</u>		<u>Page</u>
3-1	3S Subsystems Estimated Weights and Moments of Inertia with HUT	3-2
4-1	Physical Parameters of Strawman Payloads	4-7
4-2	Environmental Constraints	4-8
4-3	Pointing Requirements	4-9
4-4	Data and Command Requirements	4-10
4-5	Science Operations Requirements	4-11
5-1	Load Requirements for 3S Stellar-Pointing Mission (Instrument: HUT)	5-12
5-2	Load Requirements for 3S Solar-Pointing Mission (Instrument: Solar Corona Studies (SCS) Cluster)	5-12
5-3	3S Battery Requirements	5-13
5-4	3S End-of-Life Solar Array Performance	5-14
5-5	3S Solar Array Requirements	5-15
5-6	Power Profile During Stellar-Pointing Mission	5-18
5-7	Component Dimensions	5-19
5-8	Space Station Spartan Thermal System Louver and Heater Requirements	5-21
5-9	C&DH Characteristics	5-23
5-10	3S Communication Subsystem Link Calculation	5-25
5-11	Expected Performance of ACS Configurations	5-33
5-12	Flight Dynamics Characteristics	5-35
5-13	Mission Scenarios	5-40
5-14	3S Propulsion Subsystem Propellant Requirements	5-40
5-15	3S Propulsion Subsystem Cold Gas (N ₂)/Hydrazine Trade-offs	5-46

ACRONYMS

ACS	Attitude control subsystem
AFD	Aft flight deck
AIA	Avionics interface adapter
ASP	Attached Shuttle payload
bp1	Bits per inch
C&DH	Command and data handling
CCTV	Closed-circuit television
CDHS	Command and data handling subsystem
CDOS	Customer data operations system
c.g.	Center of gravity
CGSE	Customer ground-support equipment
CITE	Cargo integration test equipment
CMD	Command
DBSFSS	Drop box Spartan flight support structure
db	Decibel
dbm	Decibel relative to a milliwatt
dc	Direct current
DEMUX	Demultiplexer
DET	Direct energy transfer
EMC	Electromagnetic compatibility
EOL	End of life
ESA	European Space Agency
EUV	Extreme ultraviolet
EVA	Extravehicular activity
GAS	Get Away Special
GSE	Ground-support equipment
GSFC	Goddard Space Flight Center
HUT	Hopkins Ultraviolet Telescope
Hz	Hertz
I&T	Integration and test
IFU	Interface unit
IPS	Integral propulsion system
ISEE	International Sun-Earth Explorer
IUE	International Ultraviolet Explorer
IVA	Intravehicular activity
kbps	Kilobits per second
KUSP	Ku-band signal processor
LOS	Line of sight
MACS	Modular attitude control system

ACRONYMS (Continued)

MHz	Megahertz
MLI	Multilayer insulation
MMS	Multimission Modular Spacecraft
MMSE	Multimission-support equipment
MPE	Mission peculiar equipment
MPSS	Mission peculiar equipment support structure
MRMS	Mobile remote manipulator system
MST	Module servicing tool
MUX	Multiplexer
NASA	National Aeronautics and Space Administration
NASA HQ	NASA Headquarters
NASCOM	NASA Communications Network
Ni-Cd	Nickel-cadmium
n.mi.	Nautical mile
OMV	Orbital maneuvering vehicle
PCM	Pulse-code modulation
PDI	Payload data interleaver
PI	Principal Investigator
POCC	Payload Operations Control Center
ppm	Parts per million
PSE	Power supply electronics
QCM	Quartz-crystal microbalance
REM	Release-engage mechanism
RF	Radio frequency
RMS	Remote manipulator system
ROM	Rough order of magnitude
RSS	Rotating service structure
3S	Space Station Spartan
3SGSE	3S ground-support equipment
3SOCC	Space Station Spartan Operations Control Center
SA	Solar array
SCS	Solar corona studies
S/D	Serial/digital
SESAC	Space and Earth Science Advisory Committee
SFSS	Spartan flight support structure
SI	Scientific instrument
SLM	Scientific laboratory module
SMM	Solar Maximum Mission
SMRM	Solar Maximum Repair Mission
SOHO	Solar and Heliospheric Observatory
SPOC	Shuttle Payload of Opportunity Carrier
SRW	Standard reaction wheel
S/S	Space Station

ACRONYMS (Continued)

STOL	Standard Test and Operations Language
STS	Space Transportation System
SURS	Standard umbilical retraction system
TBD	To be determined
TDRS	Tracking and Data Relay Satellite
TDRSS	TDRS system
TFSUSS	Task Force on Scientific Users of Space Station
TLM	Telemetry
UIT	Ultraviolet Imaging Telescope
UV	Ultraviolet
VPF	Vertical Processing Facility

SPACE STATION SPARTAN (3S) STUDY
FINAL REPORT

1. INTRODUCTION

The Space Transportation System (STS) Shuttle Orbiter has provided an opportunity to fly and recover short-lived, free-flying satellites. The National Aeronautics and Space Administration's (NASA) Goddard Space Flight Center (GSFC) has responded to this opportunity by designing and developing a group of carriers called Spartans. These carriers have been developed using hardware and concepts previously used in the NASA Sounding Rocket and Get Away Special (GAS) Programs. The Spartan carriers primarily support free-flying experiments that require celestial pointing for astrophysics, solar physics, X-ray, and cometary phenomena. Four Spartan carriers now under development are shown in Figure 1-1.

Spartan carriers can be thought of as sounding rocket payloads that have mission lifetimes of many hours rather than a few minutes. Spartan is carried to altitude by the STS Orbiter and released to operate for up to 40 hours as an autonomous subsatellite. Spartan is then retrieved by the Orbiter and returned to Earth for subsequent use. Figure 1-2 shows the operational scenario for a typical Spartan mission.

The Space Station Spartan (3S) (Figures 1-3 and 1-4), is intended to be an extension and enhancement of the present Spartan concept, and as such, will conduct operations from the Space Station (S/S) using the S/S's unique facilities and operational features. The 3S, which will be deployed from and returned to the S/S, will conduct scientific missions of much longer duration than possible with the current Spartan.

The 3S concept includes the following features:

- The free-flyer missions will be up to 3 months in duration.
- The 3S carrier will be parked at the S/S between missions.
- The replacement instruments will be stored at the S/S and changed out at the S/S between missions. (On-orbit repair of the instruments is not considered in this study).
- The spare 3S subsystem modules (power, command and data handling (C&DH), attitude control system (ACS), and propulsion) will be stored at the S/S; faulty modules will be replaced at the S/S.
- The 3S carrier will be serviced by the S/S and, as required, returned to Earth for refurbishment.

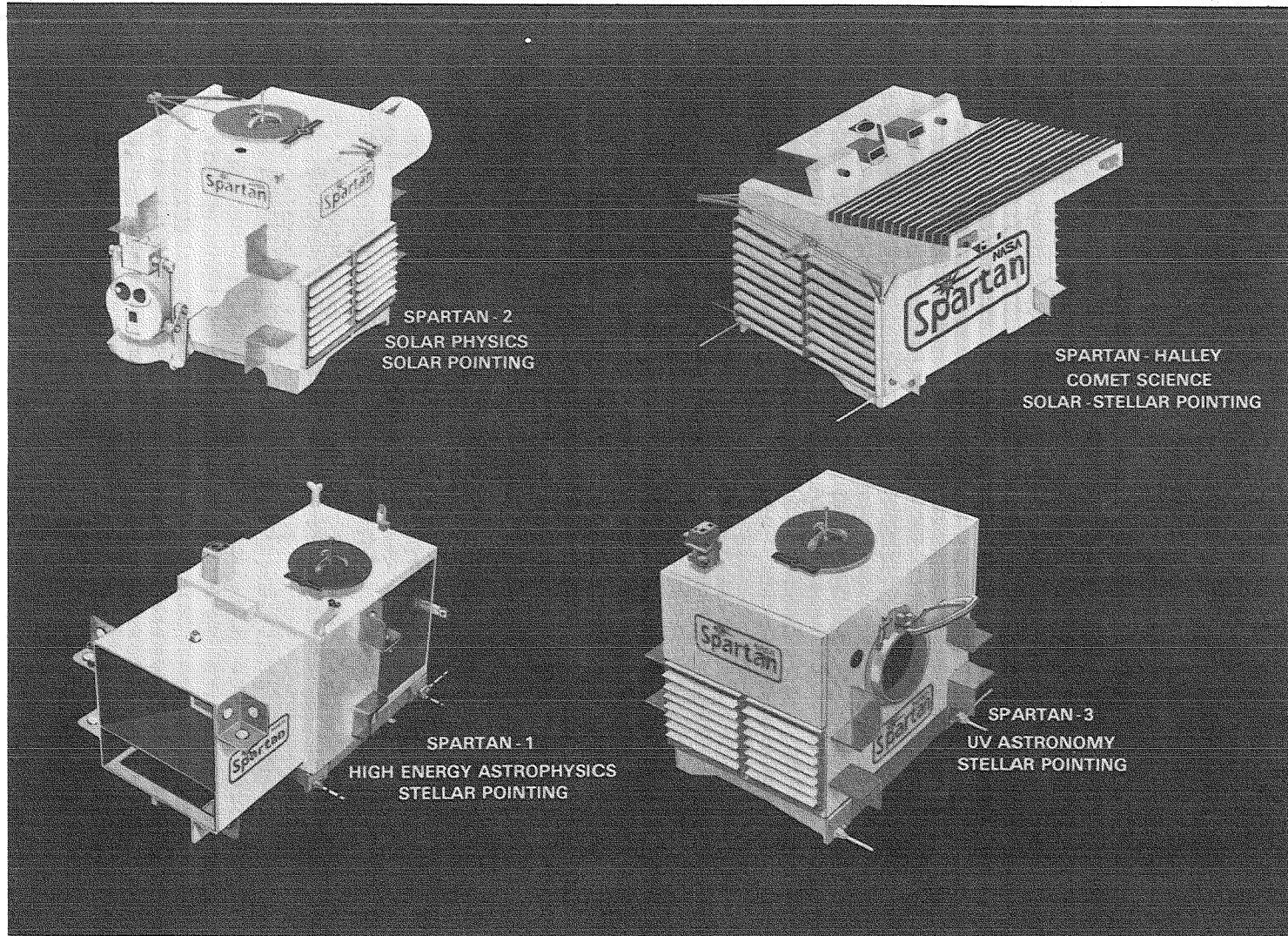

Figure 1-1. Spartan Carriers Under Development
(Current Spartan Program)

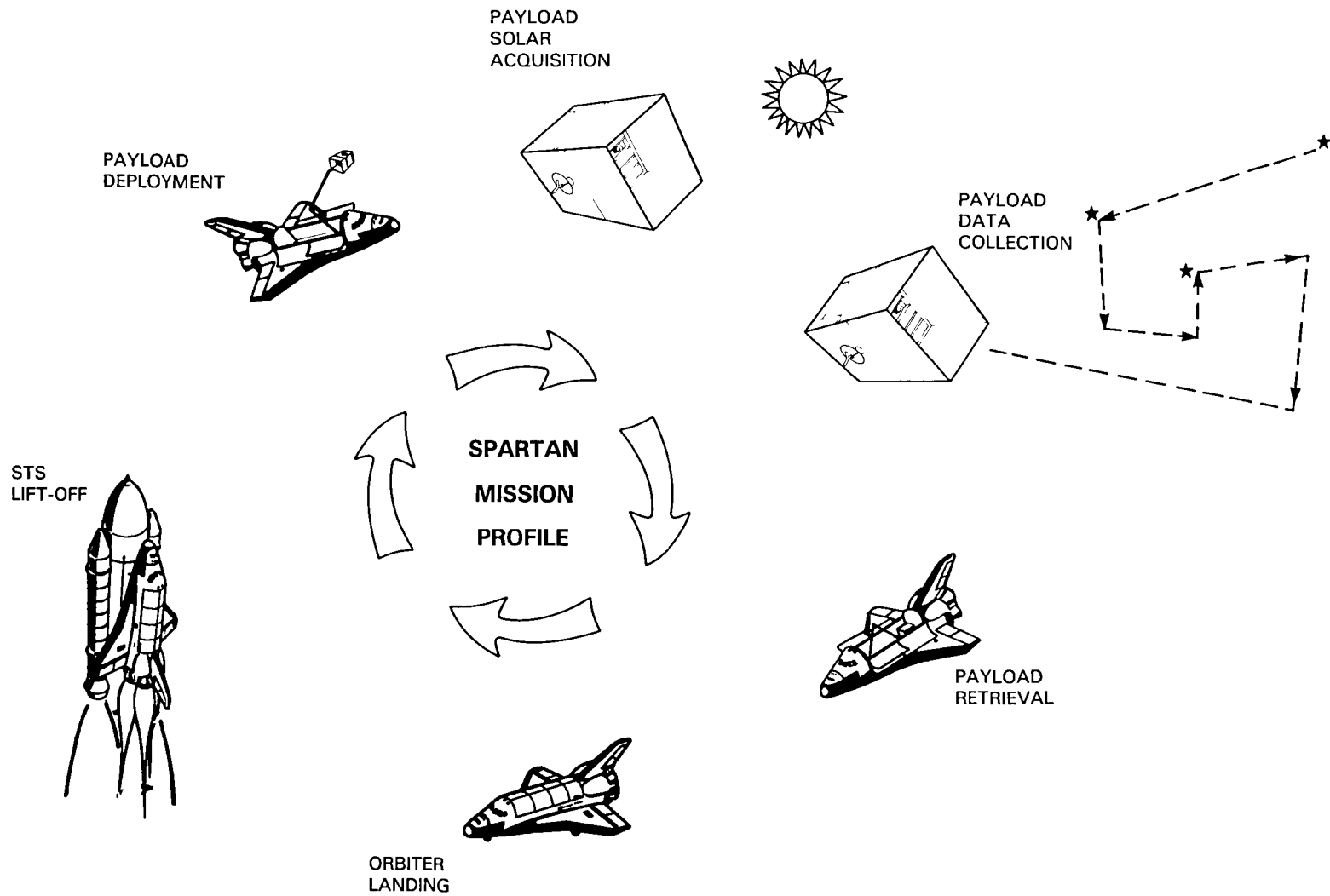

Figure 1-2. Mission Scenario for Spartan Operating from STS Orbiter (Current Spartan Program)

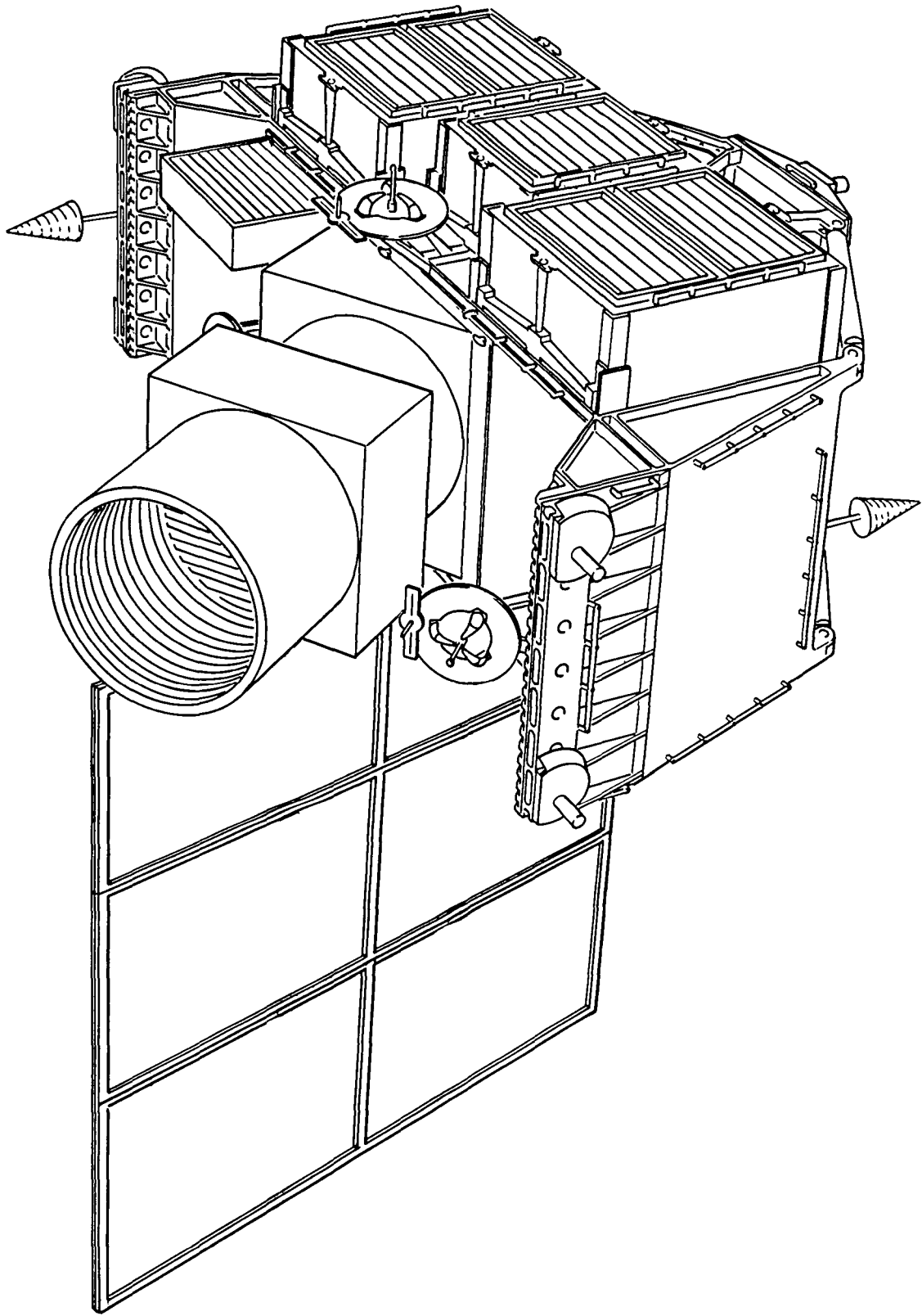

Figure 1-3. Space Station Spartan, View from Subsystem Module Side

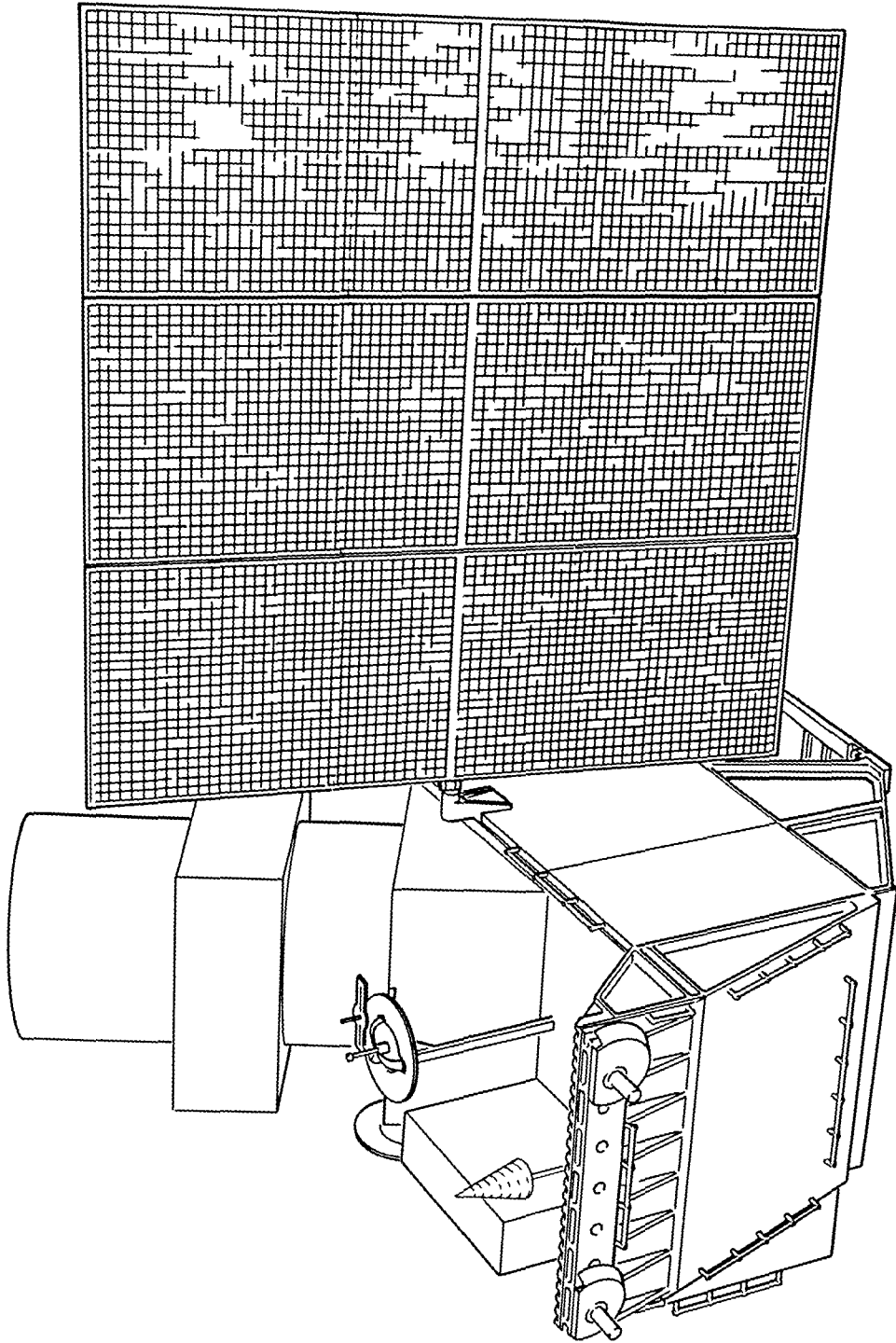

Figure 1-4. Space station Spartan, View from Solar Array side

- The Orbital Maneuvering Vehicle (OMV) will be used for deployment and retrieval of the 3S.
- A 3S Payload Specialist will not be provided on the S/S.
- The complexity of the 3S will be minimized, wherever possible, by requesting services and resources from the S/S.

1.1 BACKGROUND

In January 1984, President Ronald Reagan directed NASA to proceed with the development of a S/S. At this time, the NASA Space and Earth Science Advisory Committee (SESAC) Task Force on Scientific Users of Space Station (TFSUSS) was created. The task force was appointed under the auspices of the NASA advisory council to provide a formal means of communications between NASA and external science and applications research communities.

TFSUSS, under the terms of its charter, was charged with the following responsibilities:

- To assist NASA in planning for the scientific use of the S/S
- To assist NASA in understanding the relationship between new S/S capabilities and existing space science and applications programs
- To periodically update scientific requirements on S/S hardware and operation
- To act as a focal point for broad scientific community input into S/S activities
- To interact, as needed, with contractors during the definition phase of S/S development

The task force, under the leadership of Professor Peter M. Banks of Stanford University, met in April 1984 to consider a broad range of issues relating to both the S/S Project and the role the S/S would assume in future plans for space research.

This committee strongly endorsed the concept of a Spartan served by the S/S.

1.2 SPACE STATION SPARTAN HISTORY TO DATE

The history of the 3S to date is outlined as follows:

a. 1984

April--NASA Advisory Committee on Manned Space Station (Dr. Peter Banks of Stanford University, Chairman) begins work.

May--Dr. Novick of Columbia University (Platform Subcommittee Chairman on the Banks Committee) contacts Jon Busse for GSFC assistance.

July--Results of the "Attached Shuttle Payload (ASP) Study" of 3S provided to Dr. Novick.

August--Dr. Novick presents GSFC information to Banks Committee. Group consensus favor small, free-flying carriers.

September--ASP Project provides rough order of magnitude (ROM) cost estimate to Dr. Novick.

October 17--Dr. Novick releases draft of platform subcommittee report for comment.

November/December--3S concept reviewed with various GSFC directorates.

December--Dr. Dave Gilman, NASA Headquarters, Code EZ, requests and receives from the ASP Project preliminary data on 3S for input to the Langley Research Center data base of S/S payloads.

b. 1985

January--Draft of full Banks Committee report endorses the suitability of a Spartan serviced by S/S.

NASA/GSFC study of 3S begins.

1.3 POTENTIAL BENEFITS OF A SPACE STATION SPARTAN PROGRAM

Comments relating to the 3S concept have been abstracted from the Banks Subcommittee Report and are presented in Appendix B.

The free-flying nature of the 3S would enable a single instrument (or a single purpose instrument cluster) to view the full sky unencumbered by any S/S or S/S platform viewing restrictions. Relatively long and stable observing times for a particular target would become available, because the 3S would not interact with other experiments or with S/S platform instability, disturbances, or contamination.

The ability to meet unique scientific events (e.g., cometary phenomena) would be possible, because the 3S is deployed from the S/S and not tied to a STS launch. In addition, use of the 3S concept would make relatively small demands on the STS manifest, because new or refurbished instruments could be delivered and stored at the S/S by the STS on a space available basis. The 3S (as with current Spartans and sounding rockets) would provide pathfinder missions that enhance the laboratory development of scientific instruments. Finally, the 3S is intended to operate in the Spartan mode--a relatively low-cost, quick-reaction, quick turnaround extension of the Spartan baseline program.

1.4 SPACE STATION SPARTAN STUDY

A NASA/GSFC in-house study team was set up in January 1985. The objectives of this study were:

- To develop a credible concept for a 3S
- To define the associated requirements and interfaces with the S/S to help ensure that the Spartan will be properly accommodated

Appendix C lists the study team personnel, the study schedule, and special acknowledgements.

The end products of the study were defined as:

- A narrative (Final Report) that documented and defined the 3S concept including associated analyses and results. THIS DOCUMENT IS THE INTENDED REPORT.
- A viewgraph presentation that could be used for addressing the requirements, the designs, the interfaces, the concepts, and the scenarios to technical and management audiences.

The basic ground rules of the study were:

- A technical study should be carried out (i.e., costs not included).
- Strawman payloads should be used for the first and second missions. The Hopkins Ultraviolet Telescope (HUT) was used for the first mission and a Solar Physics Instrument Cluster was used for the second mission. See Section 4 of this report for a description of these payloads.
- The results of the study should be treated as probable inputs to industry S/S definition studies scheduled to begin in April 1985.

2. SUMMARY

2.1 SPACE STATION SPARTAN SYSTEM

3S guidelines, defined at the beginning of the study, were revised and updated as the effort progressed. These initial guidelines are as follows:

- The science mission will be up to 3 months in duration.
- The 3S carrier will be sized for Ariès class instruments* that may measure up to 44 inches in diameter and 14 feet in length.
- Instrument weights of at least 3000 pounds should be accommodated.
- The 3S carrier will be capable of supporting a total weight (3S carrier and instruments) of 10,000 pounds (to allow for instrument weight growth potential).
- The 3S will be transported to the S/S in the STS Orbiter bay with the scientific instruments mounted transverse to the Orbiter X-axis (to minimize control length).
- 3S subsystem modularity is essential. (These modules include attitude control, power, C&DH, and propulsion.)
- Radio frequency (RF) command and data links with two-way transmission to the ground through the S/S are required. Line-of-sight communications between the 3S and the S/S (range \leq 1000 nautical miles) will be maintained.
- 3S power will be obtained from a solar array and rechargeable batteries.
- Three axis attitude control of the 3S is required.
- The C&DH subsystem (CDHS) will be able to accommodate an onboard tape recorder.
- 3S redundancy will be minimal except as required for safety and for 3S retrieval.

The overall 3S configuration that resulted from this study is shown in Figures 1-3, 1-4, 2-1, and 2-2. The basic structure consists of

*Instruments that fly on the Ariès sounding rocket (the largest instruments flown on NASA sounding rockets)

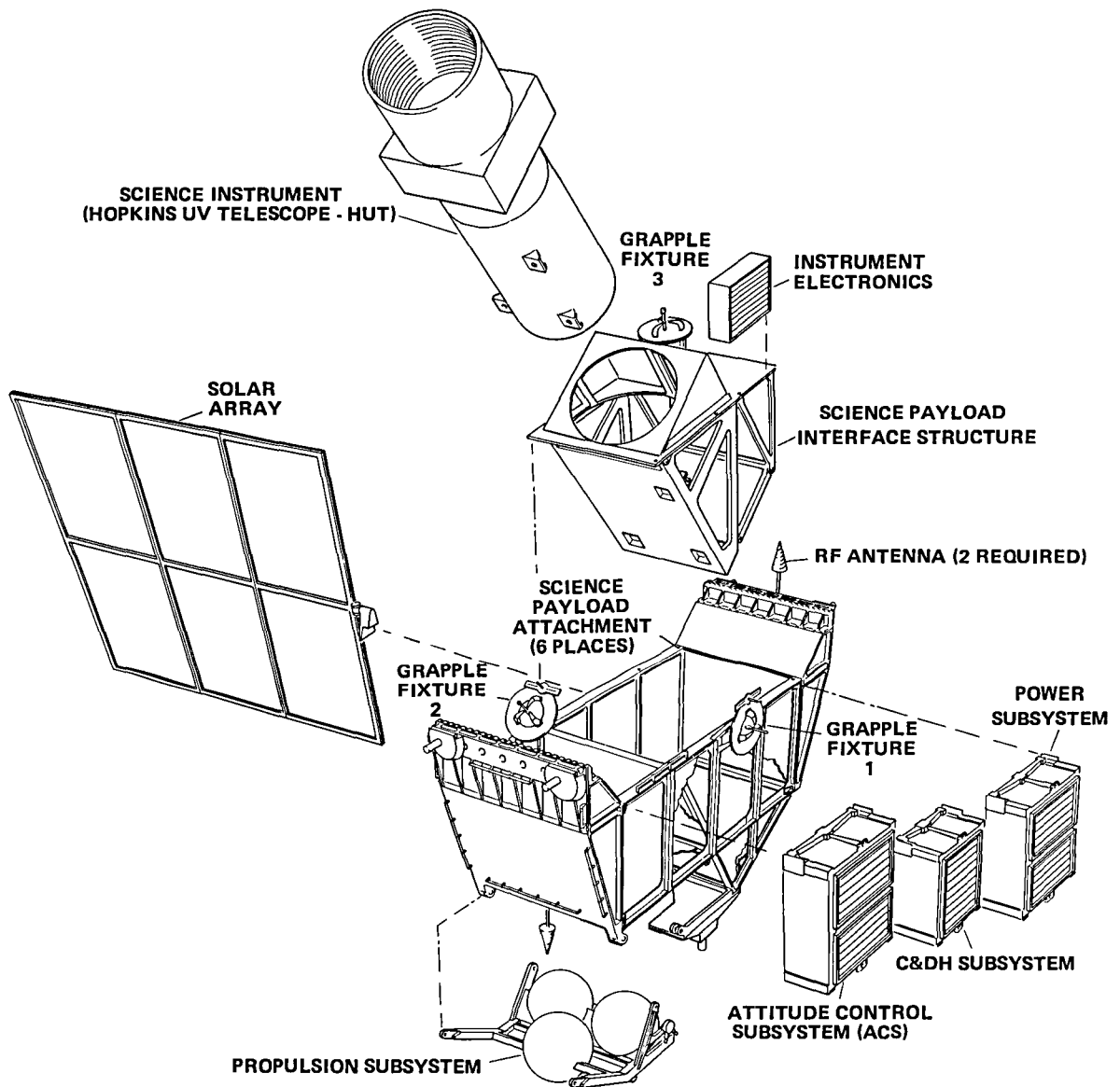

Figure 2-1. Space Station Spartan, Exploded View

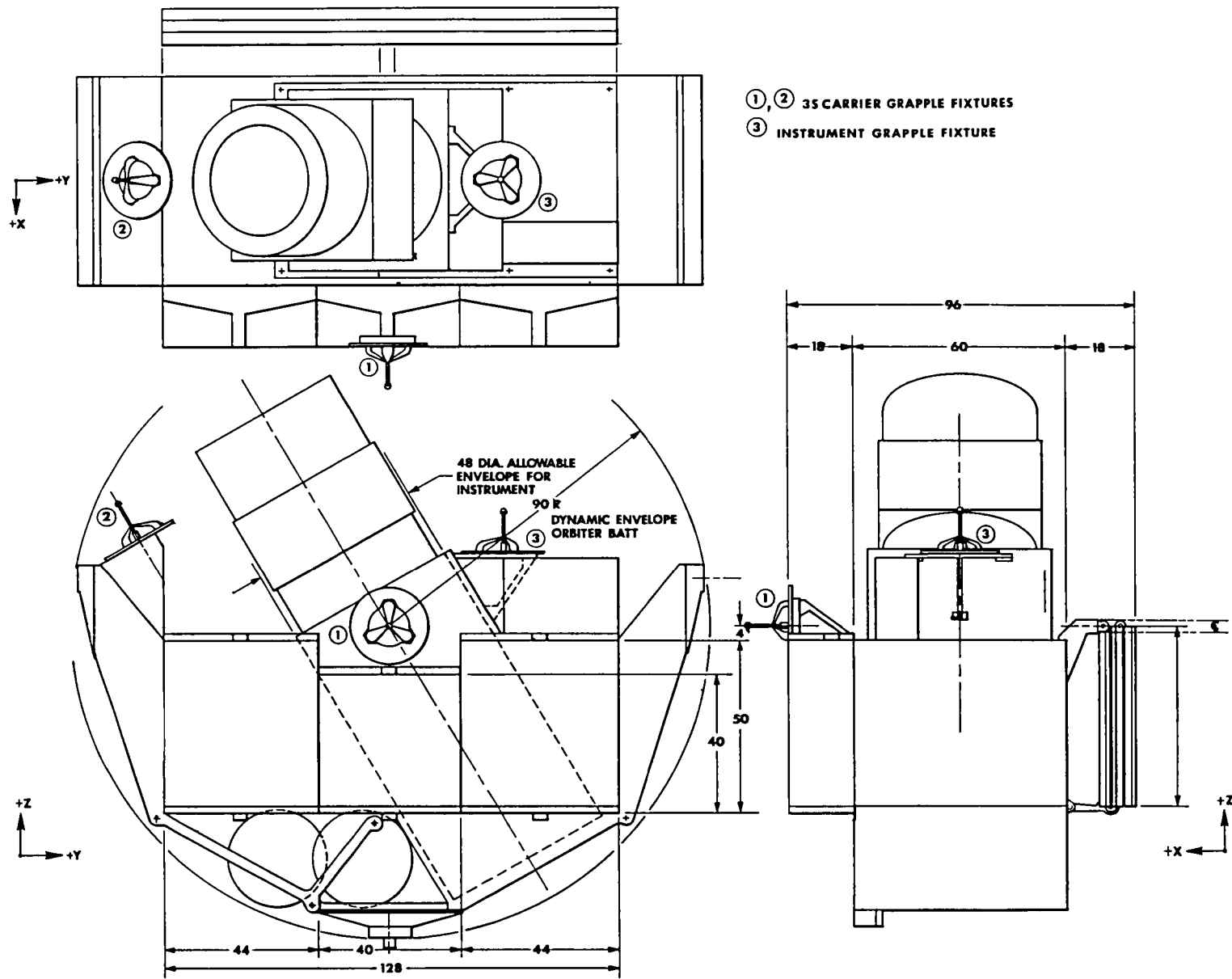

Figure 2-2. Space Station Spartan, Orthographic View
(all dimensions in inches)

an "across-the-bay" (Orbiter) bridge with provision for the attachment of replaceable ACS, C&DH, power, and propulsion subsystems and the changeout of scientific instruments.

The proposed operational scenario (typical) for the 3S Program is shown in Figure 2-3. This figure summarizes necessary STS flights between the Earth and the S/S, activities at the S/S, and deployment, data collection, and retrieval operations of the 3S and the scientific instruments. Refer to Section 3.3 for a more detailed description of operations.

During the study, more than one version of each subsystem and mode of 3S operation was considered. Figure 2-4 briefly summarizes the 3S subsystems and operational modes that were investigated. The dotted line ties together the most basic subsystems and modes, which appear to be the least complex (and presumably the least costly) in terms of the 3S. The solid line ties together the "strawman" subsystem and the modes, which are considered necessary to accomplish the objectives of the Hopkins ultraviolet telescope (HUT) and the solar physics cluster strawman payloads chosen for this study.

The basic system could serve a community of users who are satisfied with pointing capabilities similar to those of the current STS Spartan Program (10 arc-sec p-p jitter, 2 arc-min absolute pointing) but who need longer (1 to 3 month) periods of data collection. (Refer to Section 4 for a discussion of possible users.) The basic 3S system is not able to achieve the pointing requirements of the strawman payloads because of ACS limitations. Also, the basic (fixed position) solar array probably would have marginal power. The basic 3S configuration however, could be considered as a useful first step in a 3S development effort where limited early funding is a major consideration.

The strawman 3S configuration uses a sophisticated ACS to achieve low (1 arc-sec p-p) jitter, high accuracy (30 arc-sec) absolute pointing and a somewhat more complex (two position) solar array to ensure adequate power for all possible celestial targets.

When reviewing the differences between the basic (dotted line) and the strawman (solid line) configurations note that:

- The use of the most basic (simpler, lower performance) ACS increases the amount of hydrazine required by the 3S because inertia wheels are not carried.
- An intermediate ACS (with inertia wheels and STS Spartan-type gyros) is another possible choice that offers low (1 arc-sec p-p) jitter but does not improve absolute pointing accuracy.

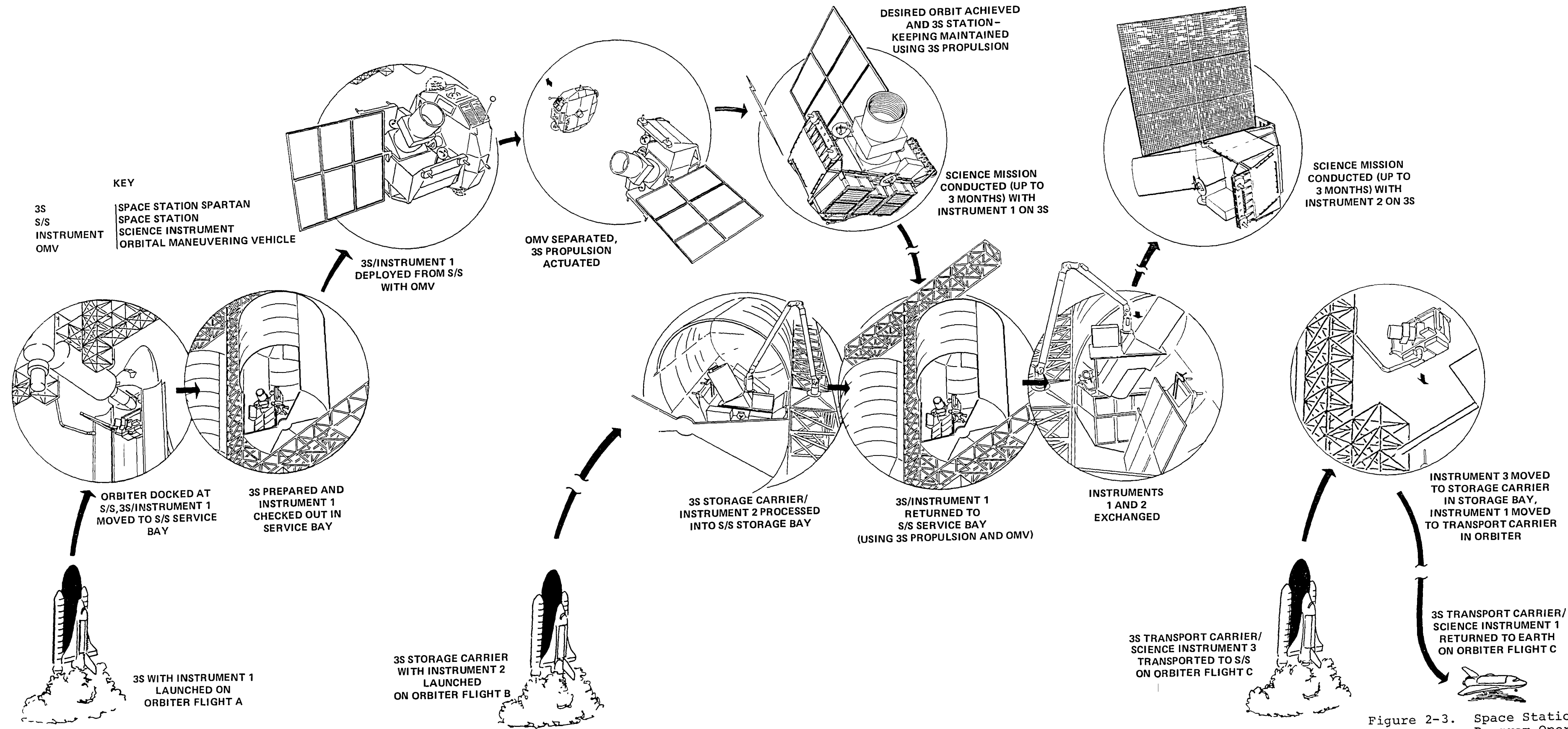

Figure 2-3. Space Station Spartan Program Operational Scenario

CONSIDERED SUBSYSTEMS AND OPERATIONAL MODES

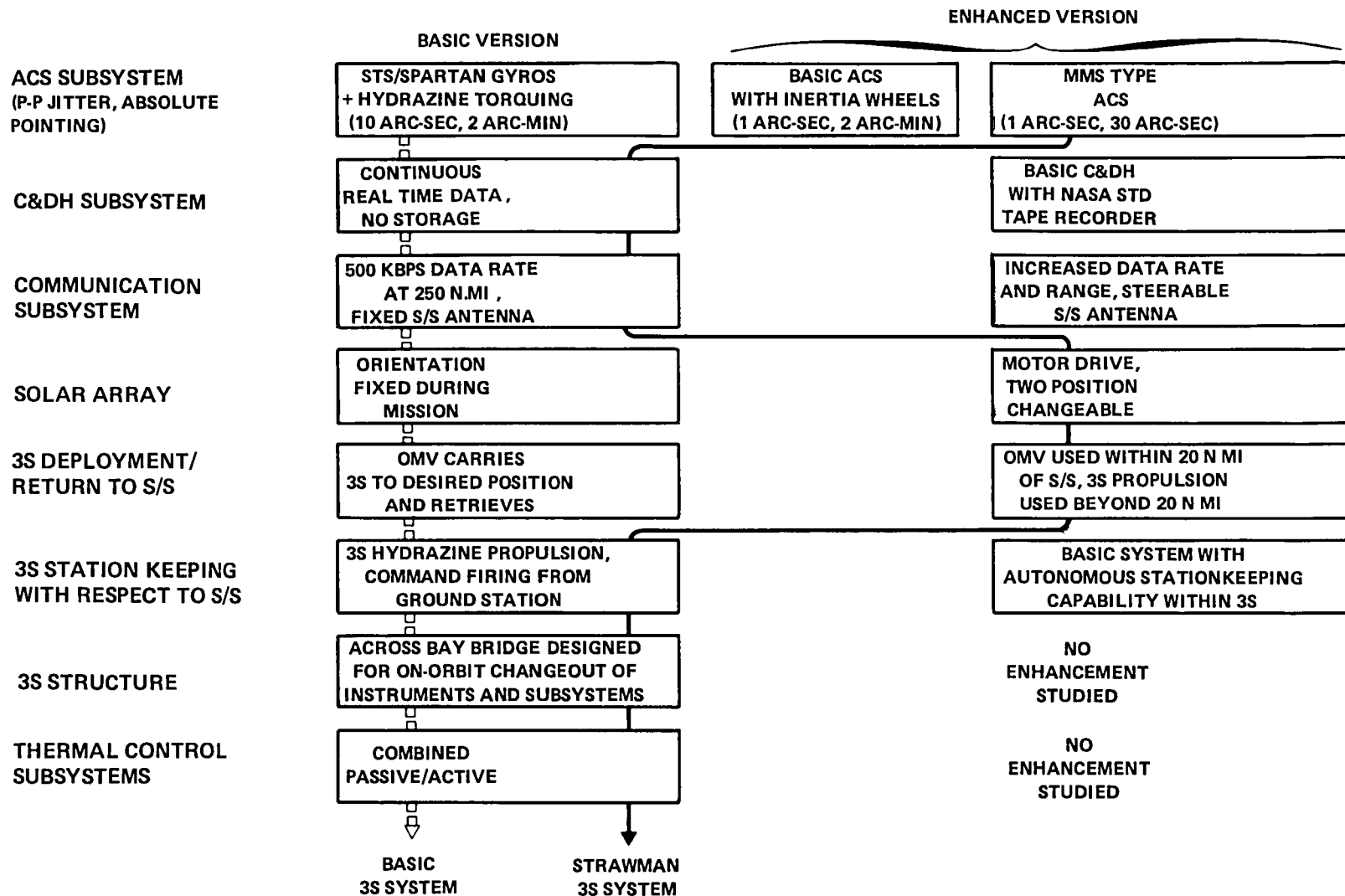

Figure 2-4. Space Station Spartan Systems, Considered Subsystems, and Operational Modes

- The basic (less complex, no tape recorder) C&DH subsystem was selected for the HUT and the solar cluster payloads because the complexity and cost of the 3S were reduced and continuous real-time data were not considered a great burden on the S/S.
- The basic (fixed S/S antenna) communications subsystem was selected for the HUT and the solar cluster strawman payloads, because the achievable 500 kilobits per second (kbps) data rate and the 250 n.mi. maximum range were considered acceptable.
- The OMV was selected for use within 20 n.mi of the S/S, because it has a cold gas propulsion system for minimal contamination and because the S/S crew has the capability to control the OMV when it is within the "control zone" (20 n.mi.).
- The 3S propulsion system was selected for use beyond 20 n.mi, because only a small increase in hydrazine was needed in addition to that already required for stationkeeping. (See next bullet.) The need for OMV support was also reduced.
- A 3S hydrazine propulsion system with firings commanded from the ground was considered the basic stationkeeping mode and was proposed for the HUT and the solar cluster strawman payloads. An enhanced version with autonomous stationkeeping capability, however, could have merit and should be considered as a future development.
- The basic 3S structure and thermal control subsystem are suitable for the HUT and the solar cluster payloads, so enhanced versions were not studied.

Additional information about the 3S system and subsystems are presented in Sections 3 and 5, respectively of this report. Further information about science payloads may be found in Section 4.

2.2 SUMMARY OF SPACE STATION ACCOMMODATION REQUIREMENTS FOR SPACE STATION SPARTAN

The following paragraphs describe the requirements that must be included in S/S plans, concept, and design in order to accommodate the 3S. Supporting information is presented in various sections of this report, especially Sections 3.2, 3.3, and 7.2.

Note that the following accommodations requirements assume that only one 3S flight carrier and only one 3S storage carrier are deployed on the S/S. A larger fleet of carriers would require proportional increases in storage space, service space, power, and RF relay capacity.

2.2.1 Mobile Remote Manipulator System

The Mobile Remote Manipulator System (MRMS) is required to move the 3S (carrier, storage carrier, and scientific instruments) and support systems on the S/S. The MRMS will perform the following:

- Move 3S with initial science instrument (1) from Orbiter to spacecraft service area
- Move OMV to spacecraft service area
- Deploy 3S/OMV
- Grapple 3S/OMV and place it in the spacecraft service area
- Move OMV to OMV refueling service area
- Move 3S storage carrier with replacement instrument (2) from Orbiter to storage area
- Move instrument 1 from the 3S to temporary storage in the storage area
- Move instrument 2 from storage to spacecraft service area
- Move instrument 1 from temporary storage to 3S storage carrier
- Move 3S from spacecraft service area to refueling bay
- Move 3S from refueling bay after refueling to spacecraft service area
- Move 3S and 3S storage carriers from spacecraft servicing or storage areas to Orbiter for return to Earth

2.2.2 Extravehicular Activity

Extravehicular activity (EVA) is required to accomplish the following 3S tasks:

- Deployment of solar array and visual inspection of 3S in spacecraft service area
- Instrument changeout--remove instrument from 3S carrier and replace with new instrument
- 3S subsystem module changeout--remove defective module and replace with spare module

2.2.3 Orbital Maneuvering Vehicle

The OMV will be used to deploy and retrieve the 3S.

2.2.4 Spacecraft Service Area

The 3S with solar array deployed will require a 15-foot diameter by 20-foot long space in the spacecraft service area. The 3S must be located in a position that ensures enough volume to attach or remove the OMV from one end and deploy the solar array at the opposite end. This volume must have longeron and keel fitting trunnion mounts to secure the 3S.

A version of the STS Standard Umbilical Retractor System (SURS) at the 3S mounting location is required for battery charging, for providing external power to the 3S and the heaters, and for 3S control, status monitors, command, and telemetry data to and from the S/S. Data and power will flow from the 3S-mounted STS/SS Interface Unit (IFU) through the SURS to the S/S crew servicing area and communication systems.

The 3S, when mounted in the spacecraft servicing area in a power-off condition, will require a thermal shroud similar to the shroud described in paragraph 2.2.5. This shroud should maintain its contents in a +7°C to +24°C temperature environment.

Instrument replacement in the 3S carrier will be performed in the spacecraft service area. The replacement procedure will require bringing the replacement instrument from the storage area, conducting EVA to remove the previous 3S instrument, installing the replacement instrument, and returning the replaced instrument to storage. Checkout of the 3S with the new instrument will be through S/S Tracking and Data Relay Satellite (TDRS) link to the GSFC Space Station Spartan Operations Control Center (3SOCC).

Replacement of the 3S subsystem modules will be performed by EVA in a manner similar to instrument replacement.

2.2.5 Storage Bay

A dedicated volume in the storage bay is required to store the 3S storage carrier. The volume required is 15-foot diameter by 8-foot length and requires trunnion/keel fitting attachments to secure the carrier. A version of the STS SURS-type umbilical is required to provide power for the survival heaters.

If a 3S carrier (i.e., operational 3S) must be stored for an extended period between missions, additional volume (15-foot diameter by 8-foot long) must be allocated in the storage bay with provisions for mounting and power.

The storage area should be equipped with a thermal shroud that provides environmental control to maintain 3S equipment between temperature limits of 7°C to 24°C when the 3S is in a power-off condition. Life cycle testing on batteries stored at relatively high temperatures (>5°C) for long periods must be carried out before this scenario is finalized.

2.2.6 Spacecraft Refueling Area

The 3S propulsion system uses hydrazine as a propellant. The spacecraft refueling area will require longeron and keel trunnion fitting attachments for securing the Spartan.

A version of the STS SURS umbilical connector is required to provide heater power and to monitor the status of the 3S.

The propellant will be loaded from the S/S storage tanks to the 3S by a standard remotely controlled quick disconnect coupling. The S/S requires a standard refueling system to load the correct amount of propellant into the 3S.

Each 3-month 3S mission will require approximately 850 pounds of hydrazine (maximum propellant weight) and 10 pounds of gaseous nitrogen for pressurization. See Section 5.8.

2.2.7 Other Space Station Requirements for Space Station Spartan

The S/S control system used for operating and monitoring the 3S will be located in the crew servicing area. This control system will provide the following:

- A hardline (electrical cable) to 3S.
- The S/S crew will be able to exercise control and display critical functions independent of 3S telemetry/command (TLM/CMD) link and will permit override of certain 3S functions as required for safety.
- Lighting for EVA, as required.
- A closed-circuit television (CCTV) for EVA, as required.
- A module servicing tool for removing and installing the modules.
- Approximately 130 watts of S/S power for initial battery charging and 25 watts for battery trickle charge when the 3S is being serviced between missions.
- A command and telemetry two-way RF link (S-band) from the GSFC 3SOCC to 3S by TDRS/S/S relay. A real-time TLM data

rate of 500 kbps and a real-time uplink of 2 kbps are required. It is anticipated that tracking information (3S with respect to S/S) will be provided by S/S as a standard service.

- An S-band, fixed-beam antenna mounted on the S/S that should have a 20° by 20° beam directed behind the S/S (i.e., opposite to the velocity vector of the S/S).
- The S/S contamination monitors located in the spacecraft service, storage, and refueling areas are required to verify the contamination environment surrounding the 3S during instrument changeout, repair, storage, and refueling.
- When the thermal shrouds are open, approximately 400 watts of S/S power are required for the survival heaters if the 3S is in the powered-down mode in the service, storage, or refueling areas.

2.3 SPACE STATION SPARTAN STUDY CONCLUSIONS AND RECOMMENDATIONS

2.3.1 Carrier Capabilities

The 3S carrier will be capable of providing the following services to an experimenter:

- The carrier will be sized for instruments that may measure up to 44 inches in diameter and 14 feet in length.
- An instrument weight up to 5000 pounds can be accommodated.
- A three axis attitude control system for stellar and solar pointing will be provided. Pointing accuracies and jitter are mission unique and are outlined in paragraph 2.3.2.
- Power of about 300 watts orbital average will be available for the instrument configuration.
- Command data will be available through a standard RS422, 1200 baud serial-digital interface.
- The telemetry system will accept low rate instrument housekeeping information through a standard 1200 baud, RS422 interface. A medium rate real-time telemetry system for instrument scientific and housekeeping data will be provided. This telemetry system will have a total data rate capability of 500 kbps.

2.3.2 Space Station Spartan Design Concepts

The subject study has established three credible 3S design concepts that vary from each other in performance and complexity. These concepts are:

- A "basic" 3S version that uses subsystems (and operational concepts) that are less complex and less costly than other versions considered below. The ACS for this system uses STS Spartan gyros and hydrazine thrusters for control. Performance is 10 arc-sec p-p for jitter, and 2 arc-min for absolute pointing. This ACS is referred to in this report as configuration 1.
- A 3S version that uses an "intermediate" ACS with STS Spartan gyros and momentum exchange wheels. Performance is 1 arc-sec p-p for jitter, and 2 arc-min for absolute pointing. This ACS is referred to as configuration 2.
- A "strawman" 3S version that uses subsystems necessary for accomplishing the objectives of the HUT and solar physics strawman payloads. A Multimission Modular Spacecraft (MMS) type ACS is used. Performance is 1 arc-sec p-p for jitter, and 30 arc-sec for absolute pointing. This ACS is referred to as configuration 3.

Based on a preliminary survey, each of these 3S versions appears to have a user group. See paragraphs 4.1.1, 4.1.2, and 4.1.3. Furthermore, it appears reasonable to believe that a 3S program initiated with the design and development of the basic 3S version could with sufficient resources evolve smoothly toward the higher performance 3S versions.

2.3.3 Propulsion

A 3S propulsion system is required for stationkeeping. Hydrazine, which is preferable over cold gas except for short (1 1/2-month) missions, is the only fuel adequate when the propulsion system is also used for ACS torquing (basic ACS). The propulsion system is well suited for moving the 3S from the vicinity of the S/S (20 n.mi.) to its desired orbital position (e.g., 250 n.mi.) and back. Only a small increase in hydrazine is required for this function beyond that already needed for stationkeeping and ACS torquing.

For 3S deployment and return to the S/S, OMV operation out to 20 n.mi. is recommended based on expected S/S safety requirements. 3S propulsion is recommended for maneuvers beyond 20 n.mi. 3S deployment by "catapult" or "differential ballistics" would further reduce use of the OMV and can be studied. 3S hydrazine propulsion system firing commanded from the ground is considered as the normal stationkeeping method. An enhanced version with autonomous station-keeping capability may have merit and can be studied.

2.3.4 Structural Subsystem

An adaptation of an "across-the-bay" structure proposed for the STS Spartan Program appears to be well suited for use as the 3S primary support structure. The proposed aluminum structure is designated as Drop Box Spartan Flight Support Structure (DBSFSS). A properly designed DBSFSS, used initially to carry class 100/200 (40-hour mission) Spartans and GAS containers, could accommodate Aries class payloads and could eventually be used as the 3S primary support structure. It is recommended that the design and application of this structure be investigated further and that fabrication of a demonstration unit be considered.

2.3.5 Power, Command and Data Handling, and Communications

The solar array design is simplified by requiring that the 3S be maneuvered to always keep the Sun in or close to the Y-Z plane (Figure 2-2), which also contains the science instrument. The array is positioned by EVA before each science mission. In the basic version of the 3S, the array remains in a fixed position during the mission. For the HUT strawman payload application it is necessary that the array angle be moved to two angular positions during the mission (using motor drive and command from the 3S ACS). The basic (no tape recorder) 3S C&DH subsystem was also selected for the strawman payloads, because 3S complexity and cost are reduced and continuous real-time data transmission is not believed to be a great burden on the S/S. The basic (fixed S/S antenna) 3S communications subsystem was also selected for the strawman payloads, because the achievable 500 kbps data rate and 250 n.mi. maximum range are considered quite acceptable. The 3S data rate can be increased from 500 to 3000 kbps by decreasing the separation distance from 250 to 100 n.mi. This data rate is considered the upper limit for the C&DH subsystem because of hardware limitations.

2.3.6 Mission Scenario

A detailed scenario has been established for operating the 3S at the S/S, and associated S/S accommodation requirements have been defined for the 3S. All support required from the S/S for 3S appears to fall within the capabilities indicated in current preliminary S/S definition documents.* The 3S study results should

*"Space Station Definition and Preliminary Design," Request for Proposal, September 15, 1984;
"Space Station Reference Configuration Description," JSC-19989, August 1984.

be useful to more detailed, upcoming industry definition studies of the S/S.

Changeout of 3S science instruments at the S/S appears feasible. Instrument-to-ACS alignment, however, is a concern that requires investigation. 3S subsystem module changeout at the S/S is feasible using techniques similar to those used for the Solar Maximum Repair Mission (SMRM).

The 3S scenario that was developed depends on EVA's for many activities including solar array deployment and positioning, thermal louver cover removal and installation, instrument changeout, 3S subsystem replacement, and transfer of "separated" instruments and modules into and out of a 3S transport carrier that remains in the Orbiter cargo bay. The turnaround time between two 3S science missions may be as short as a few days, assuming that the necessary S/S support coincides with a suitable science window.

2.3.7 General

Cost estimates for the 3S are not included in the current study. 3S cost studies will be conducted in the near future. Future studies could explore the utility and feasibility of an "economy" version of the 3S that uses cold gas for propulsion and ACS torquing, and is limited to missions of 1 month or less with restricted instrument weights and inertias.

3. SPACE STATION SPARTAN SYSTEM DESCRIPTION

3.1 SPACE STATION SPARTAN PHYSICAL DESCRIPTION

The 3S consists of a standard carrier system (3S carrier) that supports mission-unique scientific instruments. The 3S with the strawman HUT instrument will have a gross weight of approximately 6000 pounds. Total 3S weights up to 10,000 pounds are feasible because of the carrier's inherent strength (based on preliminary design and analysis using load factors of +8.0, +4.5, and +8.0 in the Orbiter bay X, Y, and Z directions).

Figures 1-3 and 1-4 show the 3S in free orbit with the solar array deployed. Figure 2-1 is an exploded view of the 3S and shows the location and attachment of the modular subsystems and the HUT instrument. Figure 2-2 is a three-view drawing that provides major dimensions of the 3S configuration.

Table 3-1 lists the estimated weight breakdown and moments of inertia for the 3S carrier with the HUT payload. The 3S carrier consists of the following major subsystems:

- Carrier structure
- Power
- Command and data handling
- Communications
- Attitude control
- Propulsion
- Thermal control

These subsystems are described briefly in this section and are discussed in greater detail in Section 5 of this report.

3.1.1 Carrier Structure Subsystem

The 3S carrier structure consists of a primary support structure and an instrument interface structure. The primary support structure includes a central semimonocoque box to which all of the 3S subsystems are attached. The trunnion fittings permit this structure to be mounted both in the STS Orbiter bay and in the S/S service, storage, and refueling areas. The primary support structure and its trunnion attachment points are shown in Figure 3-1.

The instrument interface structure, which supports the HUT (or other science instrument) and related instrument electronics, is attached as a unit to the 3S primary support structure by a

Table 3-1
3S Subsystems Estimated Weights and
Moments of Inertia with HUT

Subsystems	Weight (lbs) (1)	Moment of Inertia About 3S c.g. STS Coordinate Directions (slug-ft ²)		
		I _{xx}	I _{yy}	I _{zz}
Carrier				
Structure				
• Primary support structure (including trunnions) (2)	1620	1930	600	1790
• Science payload interface structure	400	60	50	70
Power				
• Module	250	120	100	185
• Solar array (including structure and drive system)	250	100	750	750
C&DH Module	100	10	40	40
ACS Module	200	100	80	150
Propulsion				
• Components and structure (with tanks dry)	320	150	140	60
• Propellant (3)	220	90	80	30
Wire Harness	100	140	40	160
Miscellaneous and contingencies (15%)	520	400	280	490
Carrier Subtotal (with propellant)	3980	3100	2160	3725
Science Payload (HUT)				
Instrument Telescope	1550			
Instrument Electronics	120			
Miscellaneous and contingencies (15%)	250			
Science payload subtotal	1920	800	500	450
Total: 3S with HUT (with propellant)	5900	3900	2660	4175

Notes:

(1) The weights of the subsystems include all components, module housing, module internal support structure, external attachment mechanism, and thermal louvers.

(2) The weight estimates assume two stabilizing trunnions--only one trunnion is used for taking STS loads, the other trunnion is used for handling at the S/S and will be lighter in weight. The weight of all trunnions, however, are assumed equal for this table.

(3) Hydrazine for HUT 3-month mission (132 lbs for stationkeeping and 88 pounds for 3S deployment/retrieval maneuvers). Tankage sized to carry up to 840 pounds of hydrazine (needed for mission where propulsion system provides all ACS torquing).

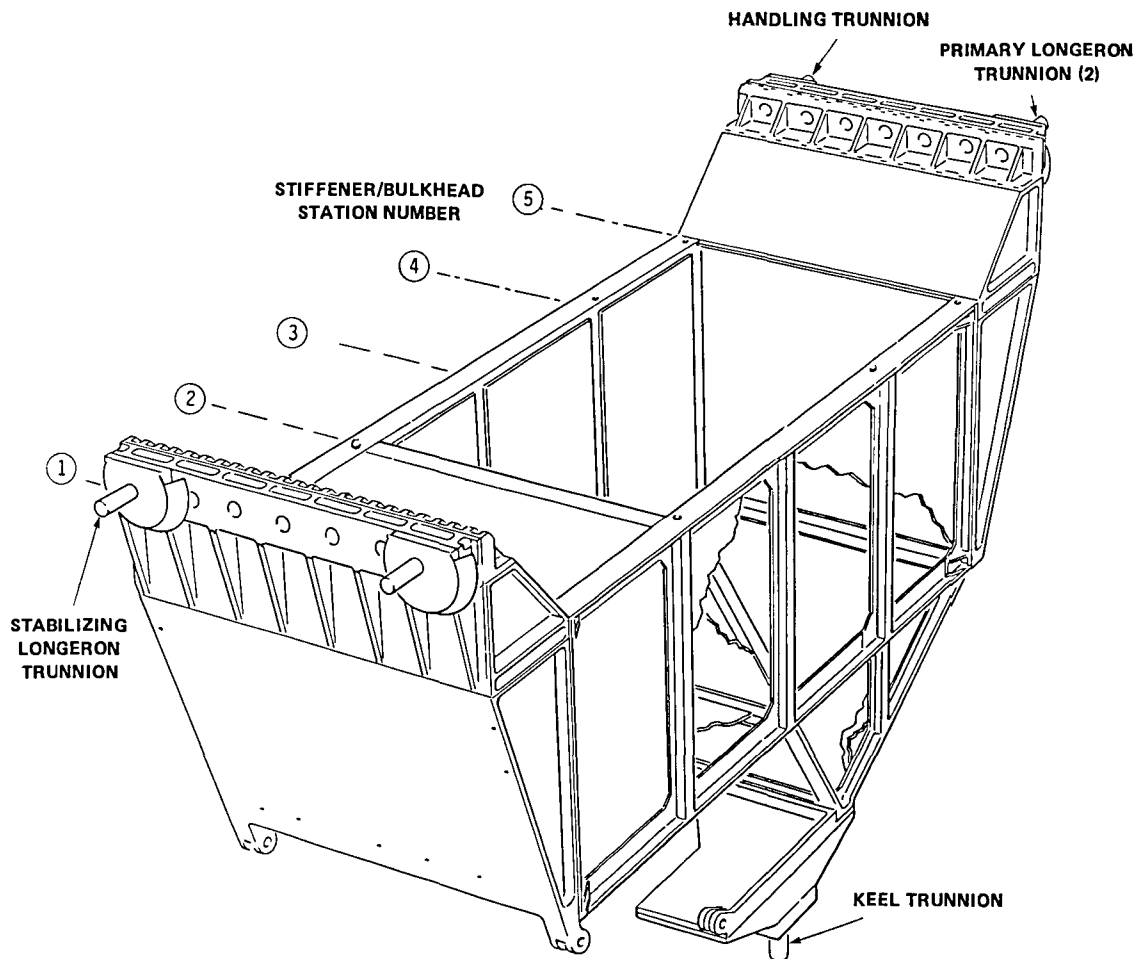

Figure 3-1. Space Station Spartan Primary Support Structure with Attachment Points to STS Orbiter

a standardized six point mechanical disconnect system shown in Figure 2-1. The instrument passes internally through the primary support structure at a 30° angle to the STS Orbiter Z-axis in a plane normal to the X-axis. This orientation allows the 3S to accommodate a maximum length instrument without interfering with the carrier's structural members or exceeding the STS dynamic envelope.

The attachment system is designed to maintain instrument/carrier alignment, to efficiently carry launch and landing loads, and to allow quick exchange of instruments. The electrical interface is a single standard connector that is self aligning and automatically engages and disengages with the changeout of the instruments.

The ACS, power, and C&DH modules are attached to one side of the box structure by MMS-type fittings that have demonstrated ease

of changeout on the SMRM. Heat dissipation and temperature control are provided for the three modules by radiators equipped with thermal heaters and covered with thermal louver assemblies.

3.1.2 Power Subsystem

The power subsystem consists of two major units: the replaceable power module and a deployable solar array containing panels that may be replaced when the 3S is at the S/S.

The power module contains batteries and related electronics. The solar array is mounted on the opposite side of the spacecraft from the power module. The array, when deployed, forms a plane surface 128 by 163.2 inches supported by a shaft that runs down the center of the array along the 163.2-inch length. The array, for storage, is folded at 54.4-inch intervals normal to the shaft to form a package of three stacked 54.4- by 128-inch panels. This package may be clamped against the side of the primary support structure central box to resist loads during Orbiter launch and landing.

Deployment and storage of the solar array at the S/S is accomplished by EVA. At all stages of deployment, the array remains within a 15-foot diameter circular envelope which has a center that is the rotational axis of the array. Thus, the array could, if desired, be deployed in the STS Orbiter bay as well as at the S/S.

The 3S power subsystem features direct energy transfer with a main power bus at +28 volts, ± 2 percent, a load capability of 642 watts orbital average for stellar-pointing missions, a load capability of 594 watts orbital average for solar-pointing missions, three 20 amp-hour rechargeable nickel-cadmium batteries, and the two-position solar array.

3.1.3 Command and Data Handling Subsystem

The CDHS is packaged in a replaceable module similar to but smaller than the power module. The CDHS features telemetry variable (by command) from 4 to 500 kbps, command rates selectable at 125, 1000, or 2000 bps, five instrument interfaces that have 1200 baud RS422 ports for low-rate data and command, adjustable real-time telemetry data rates to 500 kbps through the serial-digital ports to the medium-rate multiplexer, and selected data/command discrete links.

3.1.4 Communications Subsystem

The RF communications subsystem features a 5 watt standard S-band transponder with two hemispherical antennas that send to and receive from the S/S. These antennas are positioned on the 3S carrier to provide adequate signal regardless of spacecraft orientation with respect to the S/S.

3.1.5 Attitude Control Subsystem

The ACS is packaged in a replaceable module similar to that of the power subsystem. The subsystem features stellar- and solar-pointing capability with three-axis control and uses rate gyros, star trackers, Sun sensors, magnetometers, magnetic torquers, a microprocessor, and depending on the ACS capabilities selected, reaction wheels.

3.1.6 Propulsion Subsystem

The 3S propulsion subsystem is a self-contained unit that attaches to the load carrying structure on the underside of the carrier by six pins that allow relatively easy removal and installation. The propulsion system, which provides a stationkeeping capability, may be used for maintaining ACS control and for transporting the 3S away from and back to the vicinity of the S/S. The subsystem consists of hydrazine thrusters, latch valves, and necessary propellant tankage.

3.1.7 Thermal Control Subsystem

The thermal control subsystem consists of the thermal louvers (on the power, C&DH, and ACS modules), the thermostatically controlled heaters, the thermal blankets, and suitably treated radiation surfaces.

3.1.8 Space Station Spartan Handling Provisions

A total of three RMS grapple fixtures are attached to the 3S (Figures 2-1 and 2-2). Fixture 1 is attached to the side of the carrier on the X-axis (center line) of the Orbiter cargo bay for handling by the S/S MRMS and for attaching to the OMV. Fixture 2 is attached to the upper surface of the carrier primary structure and is used during transfer out of and into the STS Orbiter. Fixture 3 is attached to the experiment payload interface structure for removing and installing the experiment payload.

3.2 SPACE STATION SPARTAN SYSTEM INTERFACES

The 3S telemetry and command flow is shown in Figure 3-2. Note that 3S, S/S, TDRS, and ground systems are included. The S/S should provide a transparent communications link for the 3S TLM/CMD data with the ground in both the attached servicing mode and the operating mission mode. 3S generates commandable telemetry data rates between a few kbps to 500 kbps, and receives command data at the standard rates of 125 bps, 1 kbps, or 2 kbps. 3S will require continuous TLM/CMD coverage to the ground during the mission mode because onboard data storage will not exist in the basic configuration. This system is identical to that being provided on Hitchhiker-G. An optional capability, however, does exist for adding two NASA standard tape recorders in the C&DH module.

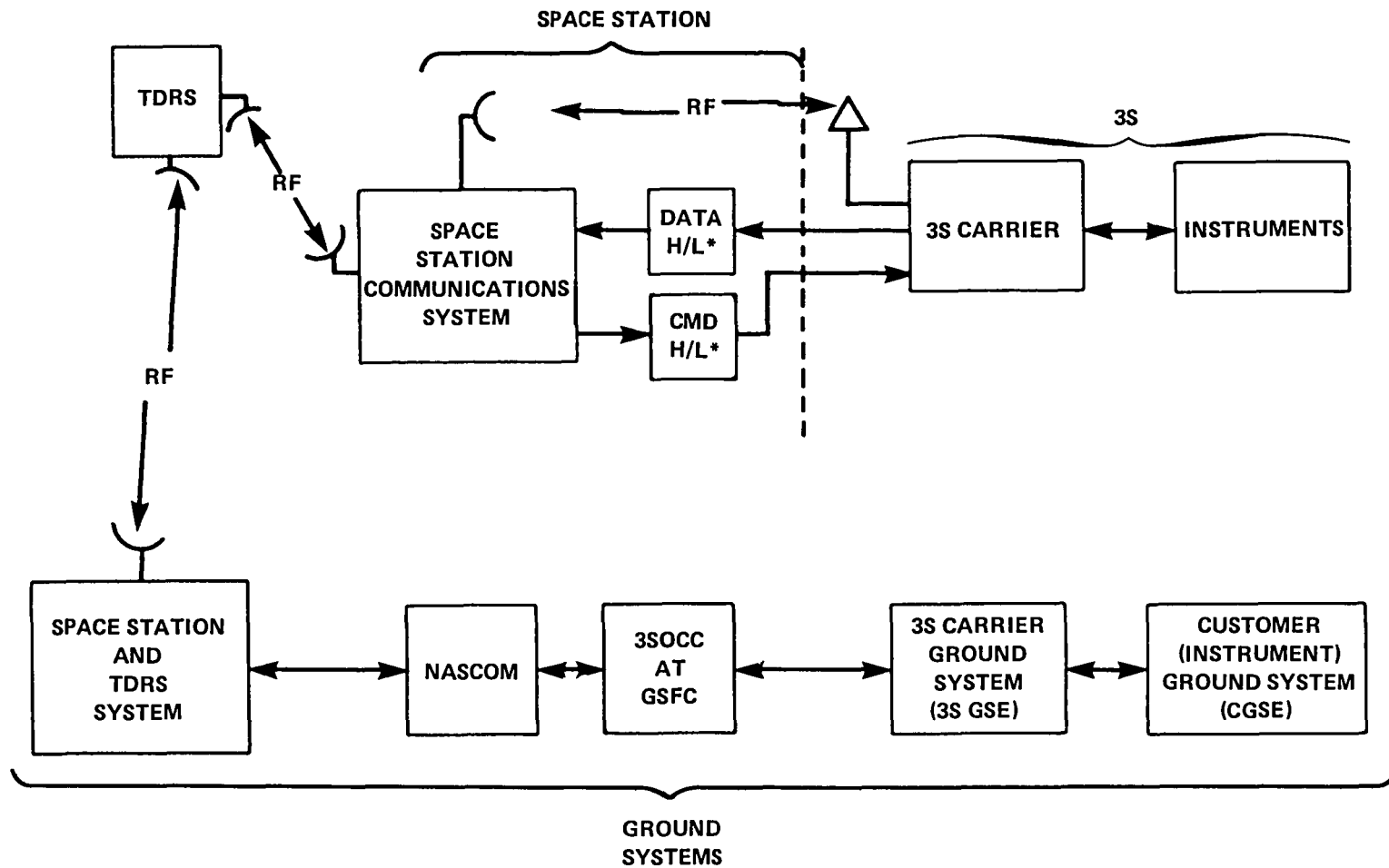

*H/L HARDLINE TLM AND CMD WHILE ATTACHED

Figure 3-2. Space Station Spartan Telemetry and Command Flow

3S communications are discussed further in Section 5.5, and ground systems are discussed in Section 6.

The block diagram for the 3S (3S carrier and science instrument) is shown in Figure 3-3. To minimize the number of electrical interface connections between subsystem modules, the TLM/CMD interfaces use differential serial-digital ports (basically one for TLM and one for CMD). The ACS and power modules will need to internally multiplex telemetry data, provide a blocked data packet on one serial-digital port, and decode commands on the other serial-digital port. In addition, a limited number of discrete data and command functions may be provided for safety or redundancy purposes. Other subsystem interface connections are required such as survival heaters, RF antennas, solar array, solar array drive, switched/unswitched power, thruster drive signals, and STS/SS hardline interfaces. A switched power relay box is located in the power module, and the hydrazine thruster valve drive electronics are located in the ACS module.

The instruments, which are intended to be routinely replaced at the S/S, will need electrical interfaces that allow easy simulation of the 3S at the Principal Investigator's (PI's) Instrument Development Facility. To allow for the transmission of data and command between the instrument and the instrument ground-support equipment (GSE) in a transparent mode, a standard electrical interface is implemented between the instruments and the C&DH module. Five instrument ports (for a five-instrument cluster) within the instrument structure will provide the following functions at the C&DH interface:

- Switched +28 V power
- Bidirectional asynchronous data 1200 baud RS-422 ports to handle low-rate data from the instrument and command data to the instrument
- Medium rate data from the instrument for rates up to 500 kbps for the total 3S.
- Optional instrument generated error signal for aid in attitude control
- Survival heater and keep-alive power

The subsystem modules are electrically mated through a docking connector mechanism similar to that used on MMS. Mating occurs as the module is physically bolted onto the carrier structure through a floating insert and alignment arrangement. The instrument interface structure provides an electrical connector docking arrangement similar to that used for the subsystem modules. The

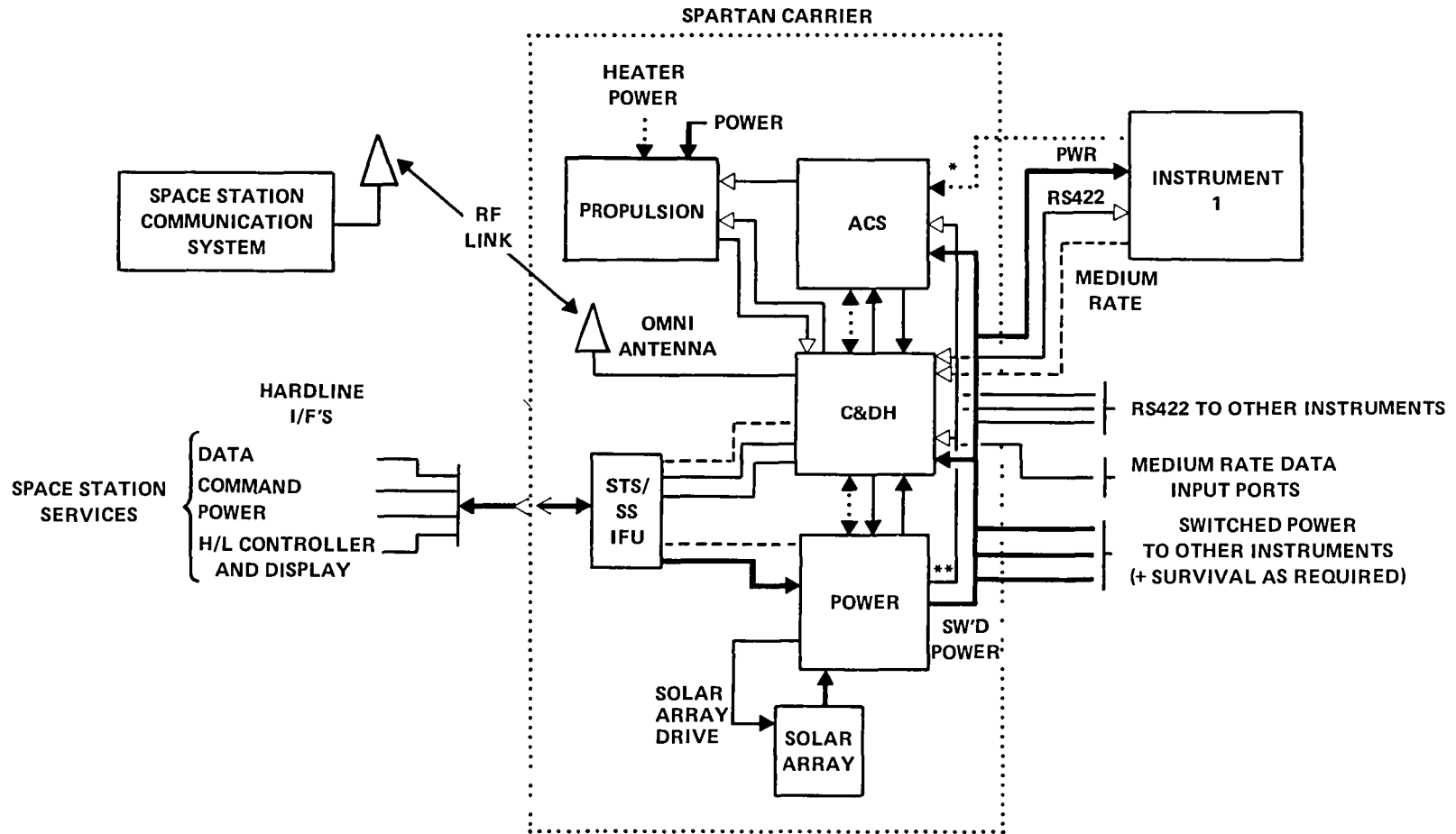

*OPTIONAL ERROR SIGNAL
 ** UNSWITCHED POWER

Figure 3-3. Space Station Spartan Block Diagram

arrangement similar to that used for the subsystem modules. The 3S carrier interfaces with the STS Orbiter and the S/S through an IFU located on the 3S carrier. This unit provides distribution and signal conditioning of the hardline functions between the 3S subsystem modules and the STS S/S.

A capability is planned within the S/S scientific laboratory module (SLM) to allow the S/S crew to exercise control and display of critical functions independent of the TLM/CMD link. The 3S expects to utilize this feature. These functions ensure the safety of the S/S and crew and provide manual operation of inhibits, power control, and system survival. Although specific functions are not identified at this phase of the program, the more general requirements to support the 3S are as follows:

a. Control Functions

- Power connect/disconnect
- Battery connect/disconnect
- Battery charge control
- Hydrazine latch valve open/close
- Survival heater enable/disable
- ACS inhibit/reset
- IFU on/off

b. Display Functions

- Power disconnect status
- Battery on/off status
- Latch valve positions
- Pressure transducer monitor
- Battery voltage monitor
- Bus voltage monitor
- Battery temperature monitor
- ACS status
- IFU on/off

The IFU contains a dc-dc power converter for internal logic. It is expected that the S/S will provide a +28 volt power source for the IFU. This +28 volt source should be controlled from the SLM. A power regulator in the IFU regulates or "cleans up" the STS or S/S +28 volt power source before it is passed on to the 3S primary power bus. The power regulator is required to handle the 3S peak load capability of 800 watts. The need for the 800-watt regulator will be evaluated when the S/S capability is defined better.

The S/S-to-3S interface connector is sized to be equivalent to the capability of the STS SURS which allows for 124 payload pins within a 128-pin connector.

3.3 SPACE STATION SPARTAN MISSION SCENARIO - OPERATIONS AT THE SPACE STATION

Several different 3S operational scenarios may be considered--each with particular advantages and disadvantages. This section describes one promising scenario that was presented in Section 2.1 (Figure 2-3). The scenario requires three different "carriers" that are defined as follows:

- a. 3S Operational Carrier--The 3S operational carrier is capable of taking scientific instruments on free-flight missions beginning from and ending at the S/S. This operational carrier is designated as 3S carrier and 3S when mated with a science instrument.
- b. 3S Storage Carrier--The 3S storage carrier is used to carry a replacement instrument and the spare 3S subsystems to the S/S, but it is not capable of conducting scientific missions. This carrier will remain in the S/S storage bay and serve as a holding fixture for instruments and 3S subsystems.
- c. 3S Transport Carrier--The 3S transport carrier is used to carry 3S instruments and subsystems between the Earth and the S/S. The transport carrier remains in the STS Orbiter bay and returns to Earth with the Orbiter.

3.3.1 3S Mission Scenario and Overview

3S, with its first science payload (e.g., the HUT instrument designated as instrument 1) will be delivered to the S/S by the Shuttle. The 3S will be in a power-off condition while in the Shuttle except for survival heater power. After the Shuttle docks with the S/S, 3S will be removed from the Orbiter payload bay by the remote manipulator system (RMS) and handed over to the S/S MRMS. This handover maneuver will require 3S to have two grapple fixtures--one for the RMS and one for the MRMS. If the MRMS had the capability to remove the 3S directly from the Orbiter bay, the number of 3S grapple fixtures could be reduced and handling could be simplified.

The MRMS will transport 3S to the spacecraft servicing area for deployment of solar array and for initial checkout before 3S deployment. If necessary, the 3S could then be placed in the S/S's thermally controlled storage bay to wait for a proper science window or the availability of adequate operational support from the S/S. 3S will be restrained in the servicing area by its STS longeron and keel trunnions. Two crew members will deploy the solar array. The SURS electrical interface will be used to connect 3S to the S/S. Checkout will be conducted by personnel in the 3SOCC at GSFC.

After successful checkout of 3S, the OMV will be moved from its storage area to the spacecraft servicing area by the MRMS. The OMV will be mated with the 3S in the spacecraft service area. The 3S grapple fixture 1 will provide the mechanical interface for the OMV. The OMV/3S combination will then be deployed from the S/S by the MRMS. The 3S will be in a low-power condition when mated with the OMV.

The OMV will use a cold gas propulsion system to maneuver a short distance away from the S/S. The OMV main bi-propellant propulsion system will be fired to raise the orbit of the OMV/3S thereby reducing orbital velocity. At a distance of 20 n.m. from the S/S, the OMV will disengage from 3S and back away a short distance using its cold gas system. The 3S will then be powered up, and its readiness to perform the science mission will be established through the 3S ground system. The OMV will then fire its main propulsion system to return to the S/S where it will be grappled by the MRMS and berthed in its service area for refueling. Meanwhile 3S will drift behind the S/S to a preassigned location (e.g., 250 n.m.). The 3S propulsion system will be fired to lower the altitude to that of the S/S. 3S will use its integral propulsion subsystem to maintain this position relative to the S/S (i.e., for stationkeeping) during its scientific mission.

While 3S is conducting the 1 to 3 month scientific mission, a Shuttle will arrive at the S/S with the 3S storage carrier. The main structure of the storage carrier will be identical to that of the operational 3S that preceded it to the S/S. This structure will contain a replacement instrument (e.g., the Solar Physics Telescope cluster designated as instrument 2) and possibly some replacement modules. This complement will be moved to the satellite storage area using a scenario similar to that previously described for the operational 3S.

After the first scientific mission is completed, 3S will be maneuvered to within 20 n.m. of the S/S using the 3S propulsion system. The OMV will rendezvous with 3S, which will then be powered down, and return 3S/OMV to within 50 feet of the S/S using the main and cold gas propulsion systems. The MRMS will grapple the OMV and place the complement in the service bay. The 3S longeron and keel trunnions will be secured, and the OMV will be disengaged from 3S and returned to its service area by the MRMS.

Activities in the S/S spacecraft service bay will consist of 3S instrument changeout and possible module replacement. Instrument changeout will consist of unbolting the first instrument by EVA and removing it from 3S with the MRMS. The first instrument will be secured in a temporary location in the storage bay so that the MRMS can be used to remove the replacement instrument (instrument 2) from the storage carrier and place it in 3S. The MRMS will then place the first instrument in the storage carrier. If necessary, a similar sequence may be used to replace a 3S module,

except that the MRMS is used in conjunction with a manipulator foot restraint to move the crew person/module.

3S propulsion subsystem refueling will occur after each mission. 3S will be moved to the refueling bay for this activity.

A 3S transport carrier will be used to bring a third science instrument to the S/S. On return to Earth, the same transport carrier will be used to remove unneeded instruments and any inoperative subsystems from the S/S.

3.3.2 Space Station Spartan Mission Scenario - Step By Step Description

A detailed step-by-step scenario for 3S operations at the S/S is presented in the following pages and is preceded by an overall view of the S/S (Figure 3-4).

3.3.2.1 Space Station Spartan Operations at the Space Station--3S operations at the S/S have been subdivided into the following categories:

- Receive and checkout
- 3S deployment operational orbit
- 3S scientific mission
- 3S replacement instruments and subsystems
- 3S retrieval
- 3S servicing including:
 - a. Instrument changeout
 - b. Subsystem module replacement
 - c. Propulsion subsystem refueling
- Return mission

3.3.2.2 Receiving and Checkout

- Shuttle maneuvers within close proximity to S/S (Figure 3-5)
- Shuttle docks at S/S
- Attach RMS to 3S grapple fixture 2 (top of 3S carrier) (Figure 3-6)

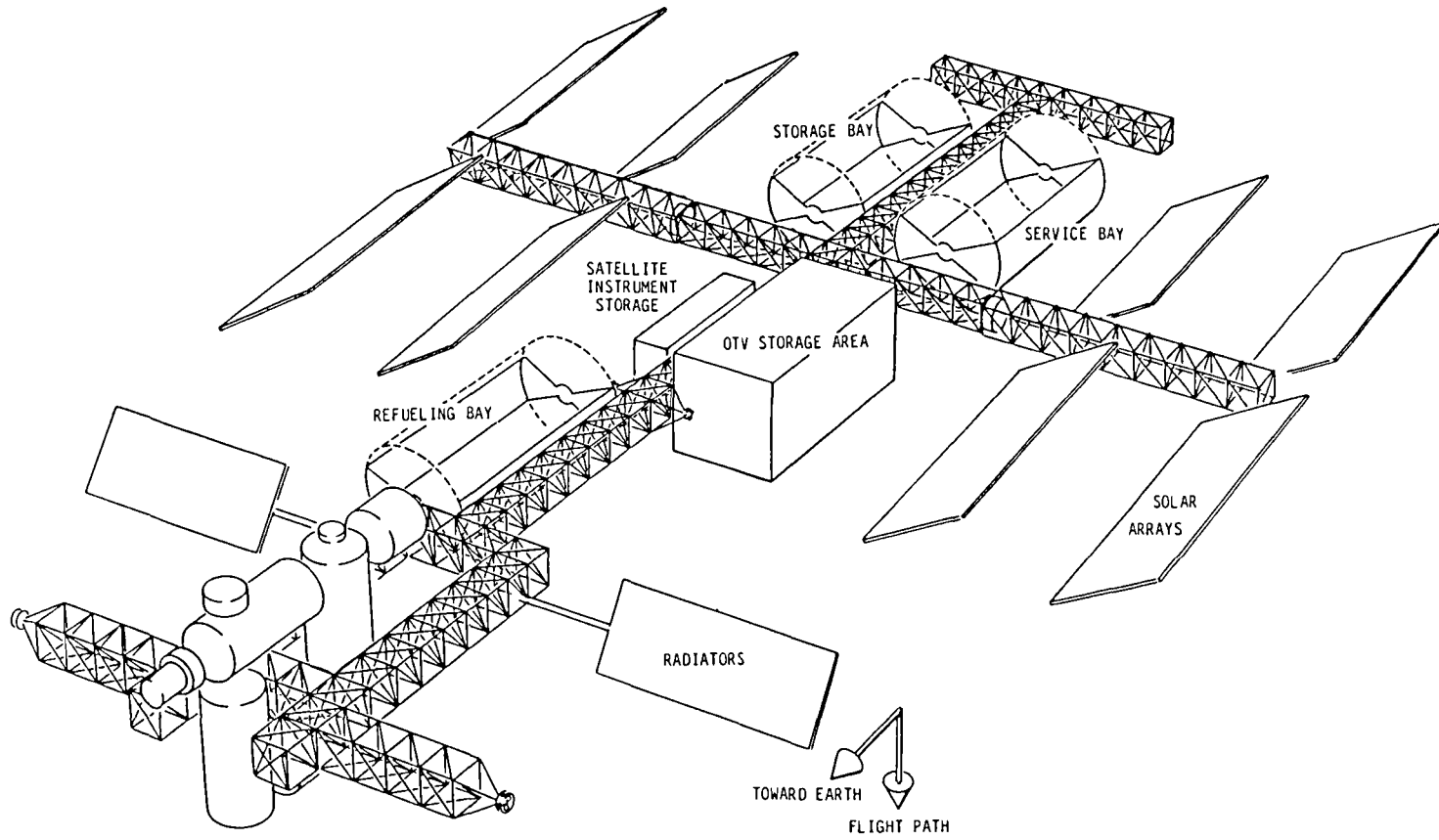

Figure 3-4. Space Station Configuration

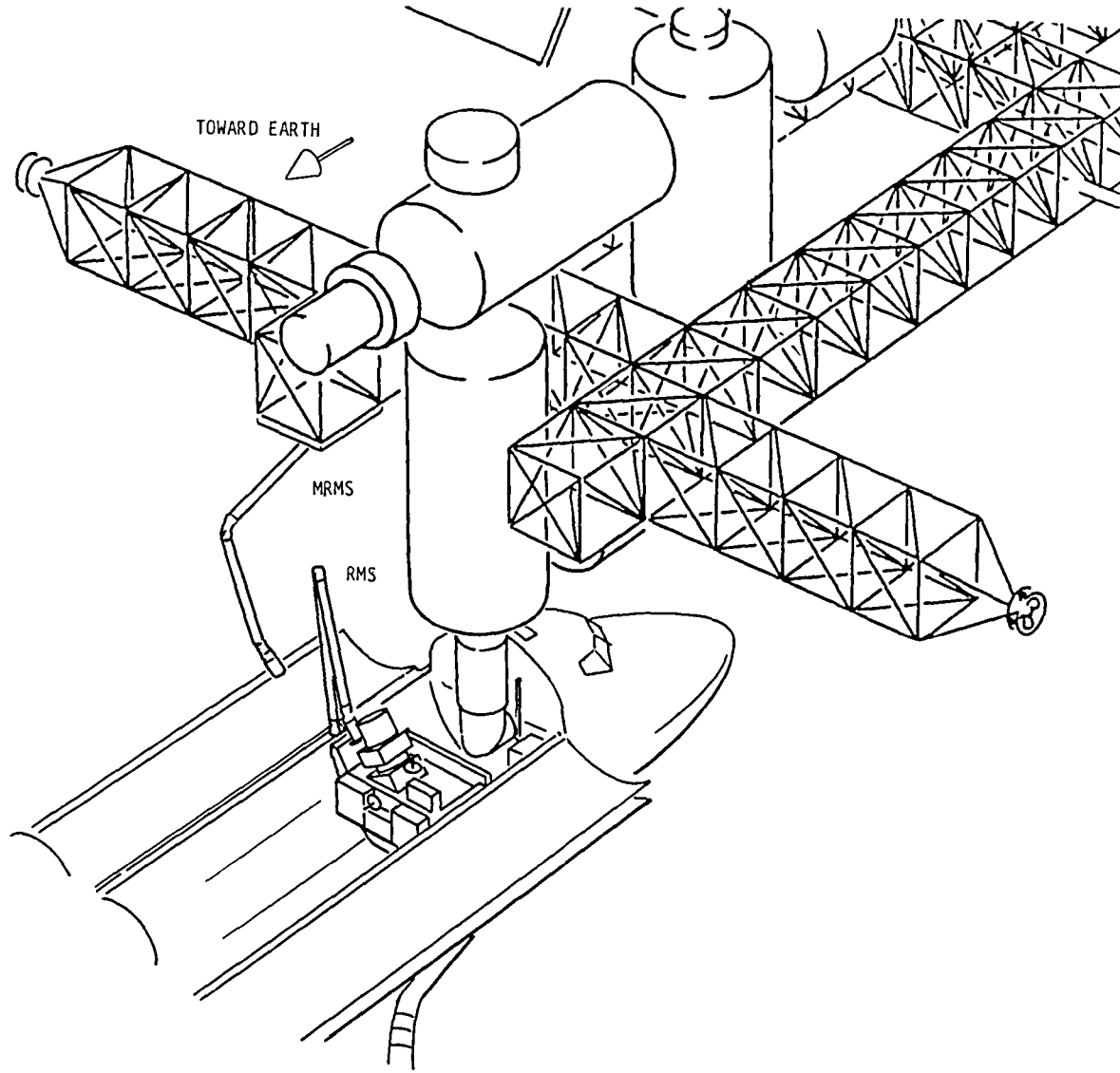

Figure 3-6. RMS Removes 3S From Cargo Bay

- Remotely disconnect STS umbilical connector (control from aft flight deck (AFD))
- Remotely open STS trunnion fittings (control from AFD)
- Remove 3S from cargo bay with RMS (control from AFD)
- Attach MRMS to 3S grapple fixture 1 (center line of 3S carrier) (Figure 3-7)
- Release RMS from grapple fixture 2
- Move 3S to spacecraft service area using MRMS (Figure 3-8)
- Place 3S in spacecraft service bay
- Remotely clamp 3S carrier trunnions
- Release MRMS from grapple fixture 1
- Remotely mate 3S carrier electrical connector
- Turn on 3S carrier survival heaters
- Close service bay thermal shroud and reopen thermal shroud as necessary for servicing
- EVA 1 to deploy solar array, conduct visual inspection, and remove thermal louver protective covers (Figures 3-9 and 3-10)
- End EVA 1
- Turn off survival heaters
- Open service bay thermal shroud
- Power up 3S
- GSFC 3SOCC conducts 3S checkout through S/S-TDRSS
- Remotely demate 3S carrier electrical connector
- 3S remains under internal power in a minimum power configuration

3.3.2.3 Deployment to Operational Orbit

- Attach MRMS to OMV grapple fixture
- Move OMV to spacecraft service area (Figure 3-11)

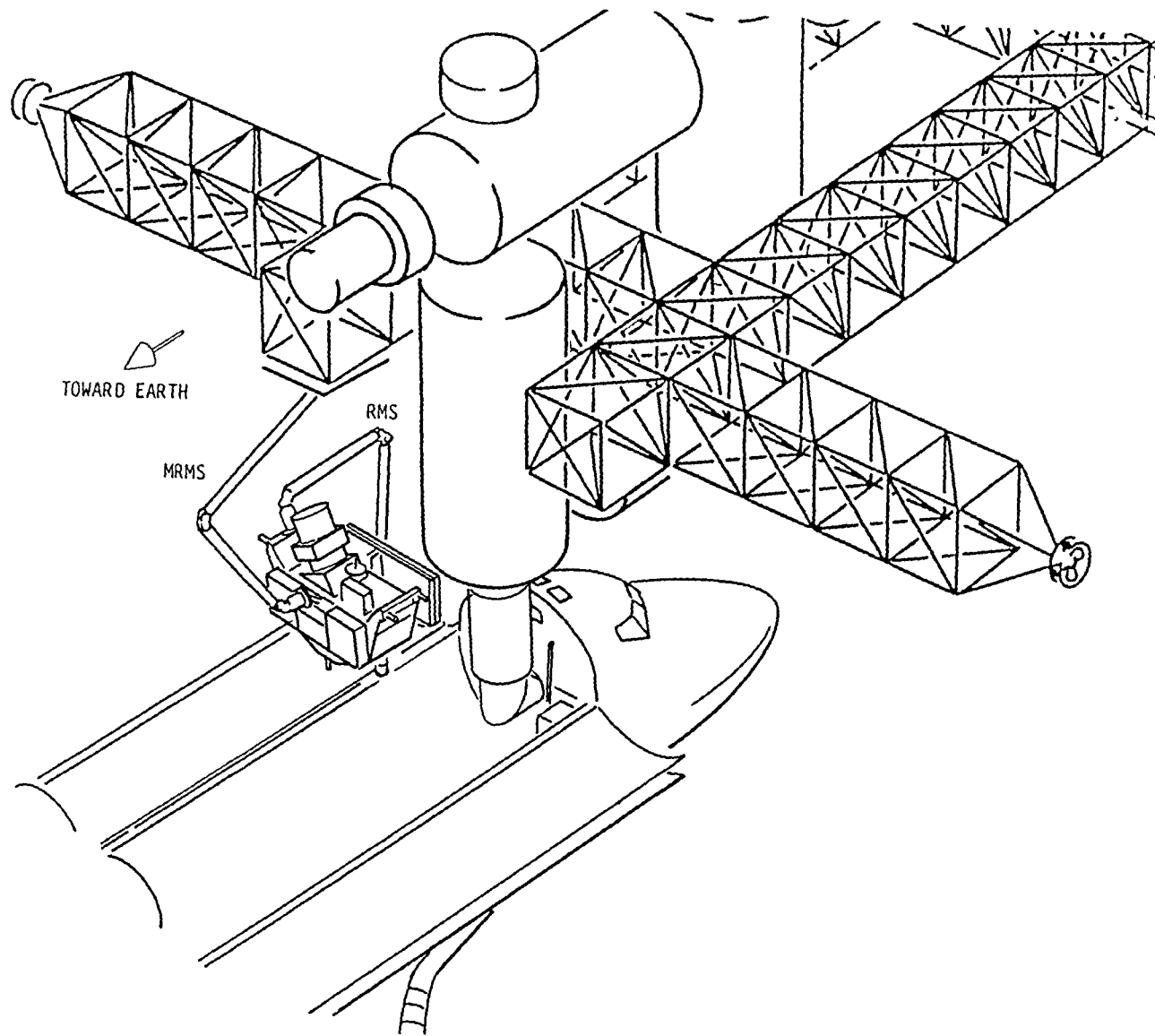

Figure 3-7. Midair Handover of 3S From RMS to MRMS

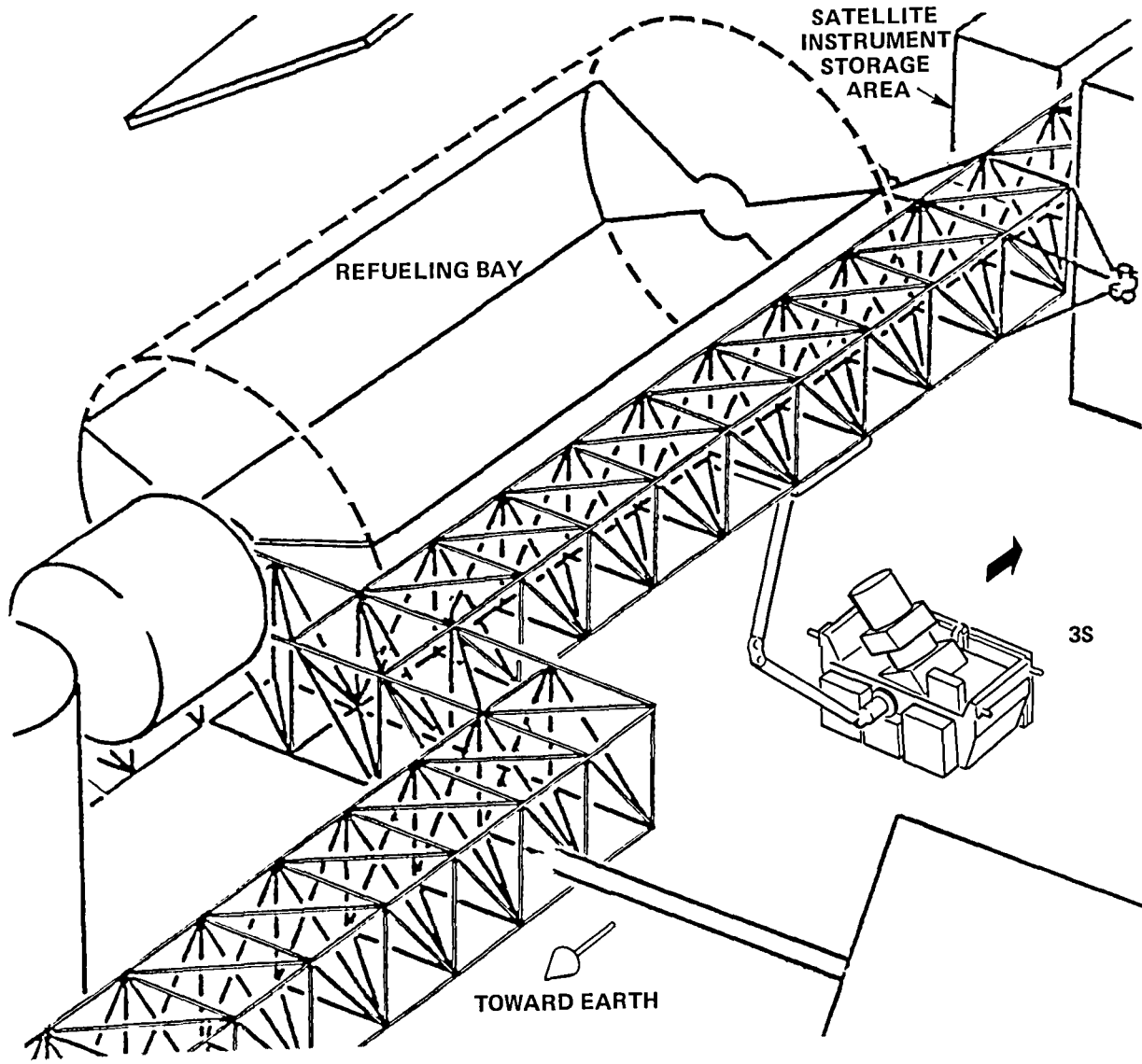

Figure 3-8. MRMS Moves 3S to Service Bay

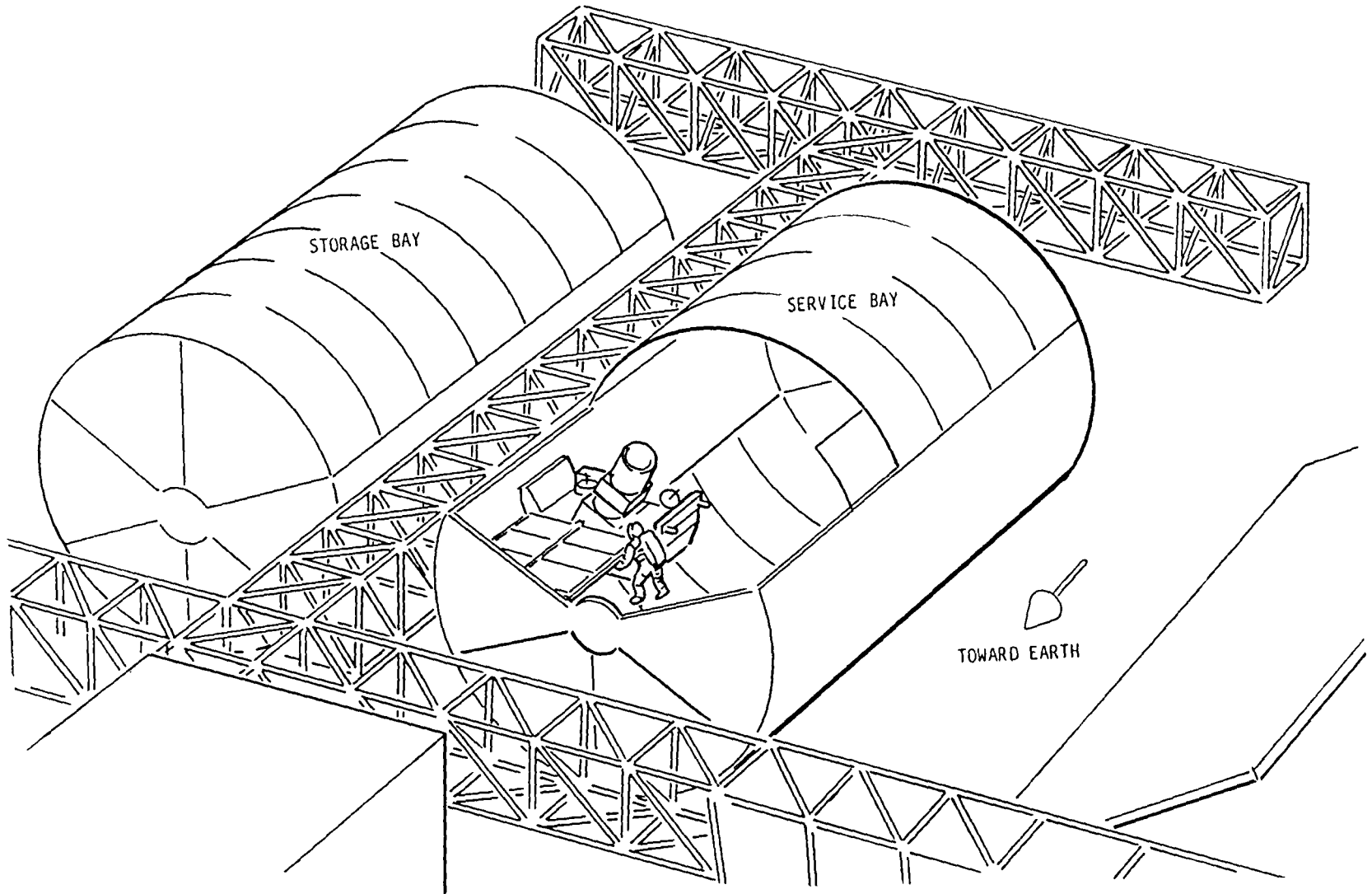

Figure 3-9. Space Station Crew Member Deploys Solar Array and Removes Louver Covers

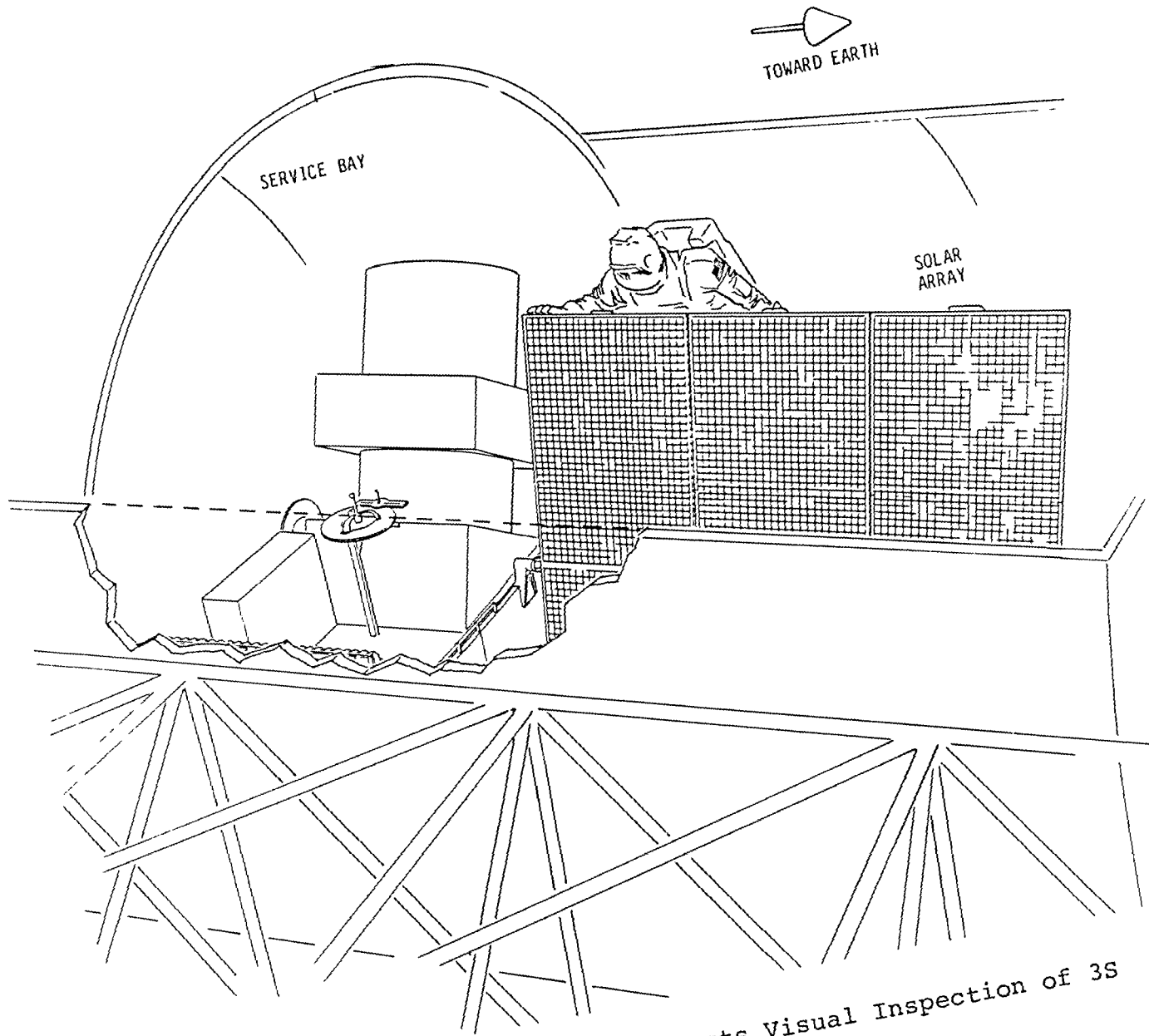

Figure 3-10. Crew Member Conducts Visual Inspection of 3S

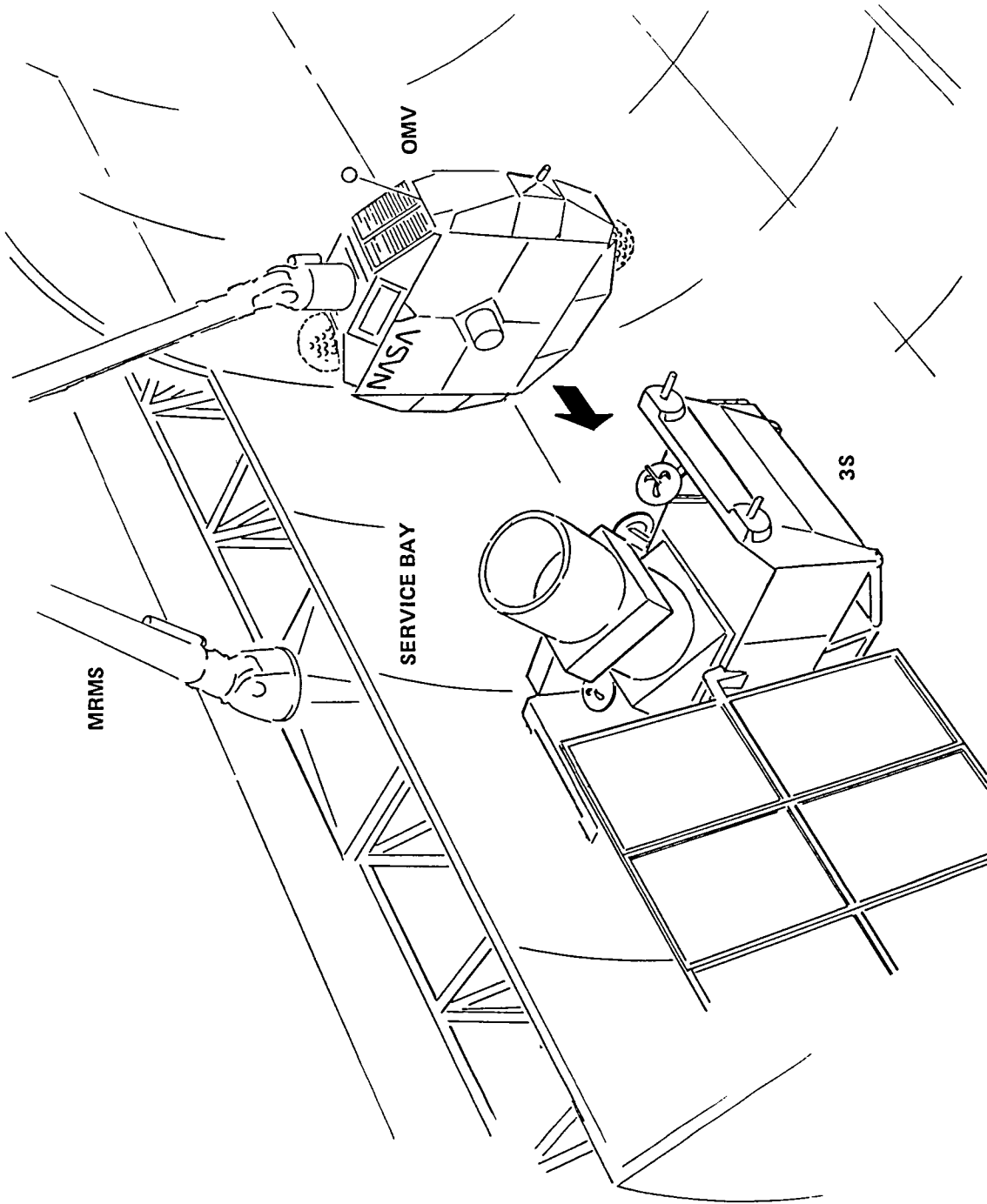

Figure 3-11. OMV Docks with 3S

- Attach OMV to 3S grapple fixture 1
- Remotely release 3S carrier trunnions
- Deploy OMV/3S with MRMS (Figure 3-12)
- OMV with 3S maneuvers short distance from S/S with cold gas system (Figure 3-13)
- OMV performs necessary maneuvers to achieve greater altitude than S/S
- OMV positions 3S to desired orientation
- OMV disengages from 3S
- 3S senses separation signal and activates appropriate sub-systems
- OMV backs away from 3S using cold gas (Figure 3-14)
- OMV performs maneuvers to return to S/S
- OMV maneuvers to within 50 feet of S/S using cold gas
- OMV is grappled by MRMS
- OMV is returned to service area for refueling
- 3S drifts 250 n.mi. behind S/S
- 3S housekeeping data will be monitored during the transfer, if feasible scientific data will also be collected
- 3S uses hydrazine propulsion system to achieve appropriate orbit at S/S altitude

3.3.2.4 3S Mission

- 3S conducts scientific mission (up to 3 months) (Figure 3-15)
- 3S is controlled from GSFC 3SOCC through S/S-TDRSS
- 3S uses hydrazine subsystem to maintain correct orbital position with respect to S/S

3.3.2.5 Space Station Spartan Replacement Instruments and Subsystems

- Shuttle arrives at S/S with 3S storage carrier, instrument 2, and possibly spare 3S subsystems (Figure 3-16)

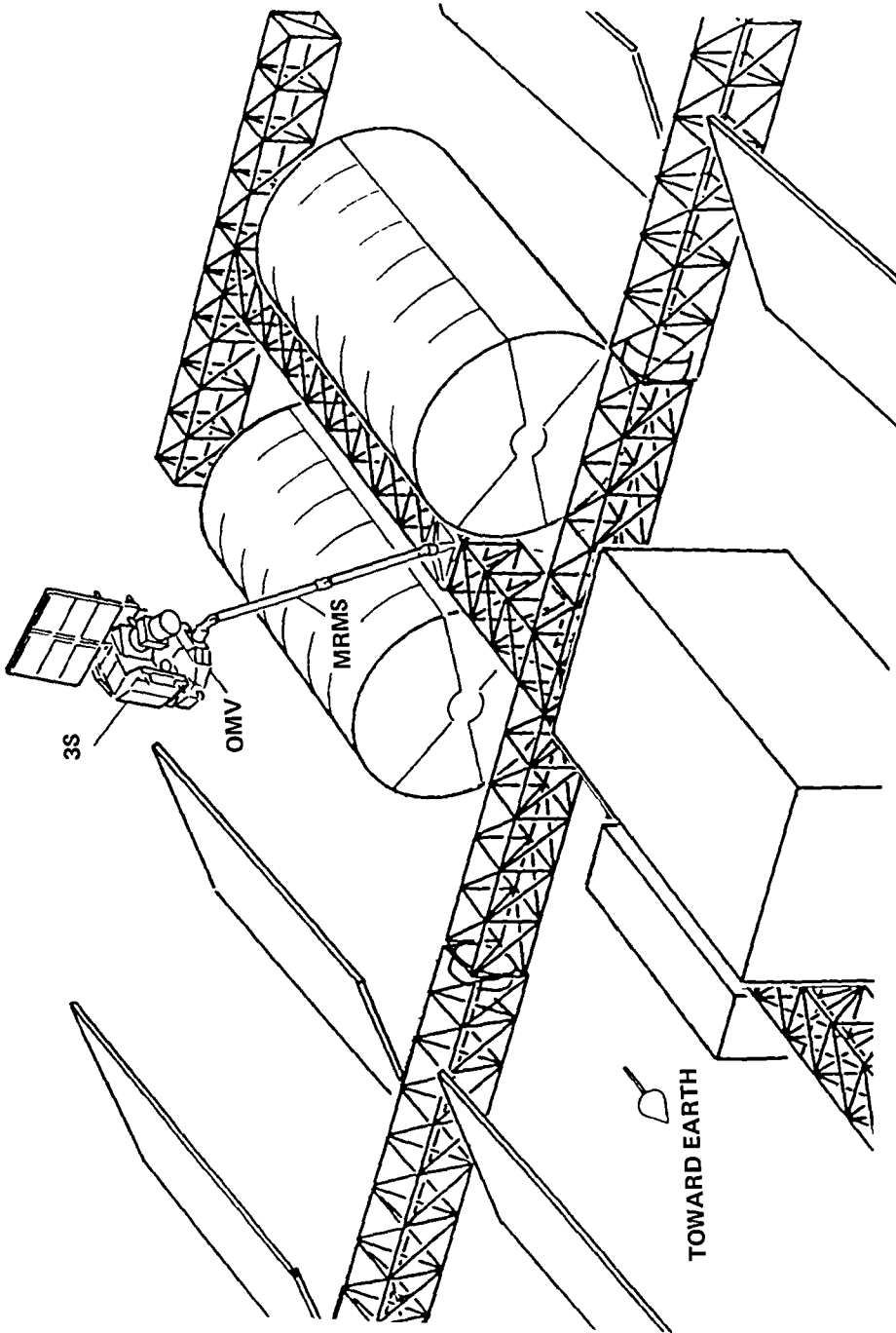

Figure 3-12. OMV/3S Deployed by MRMS

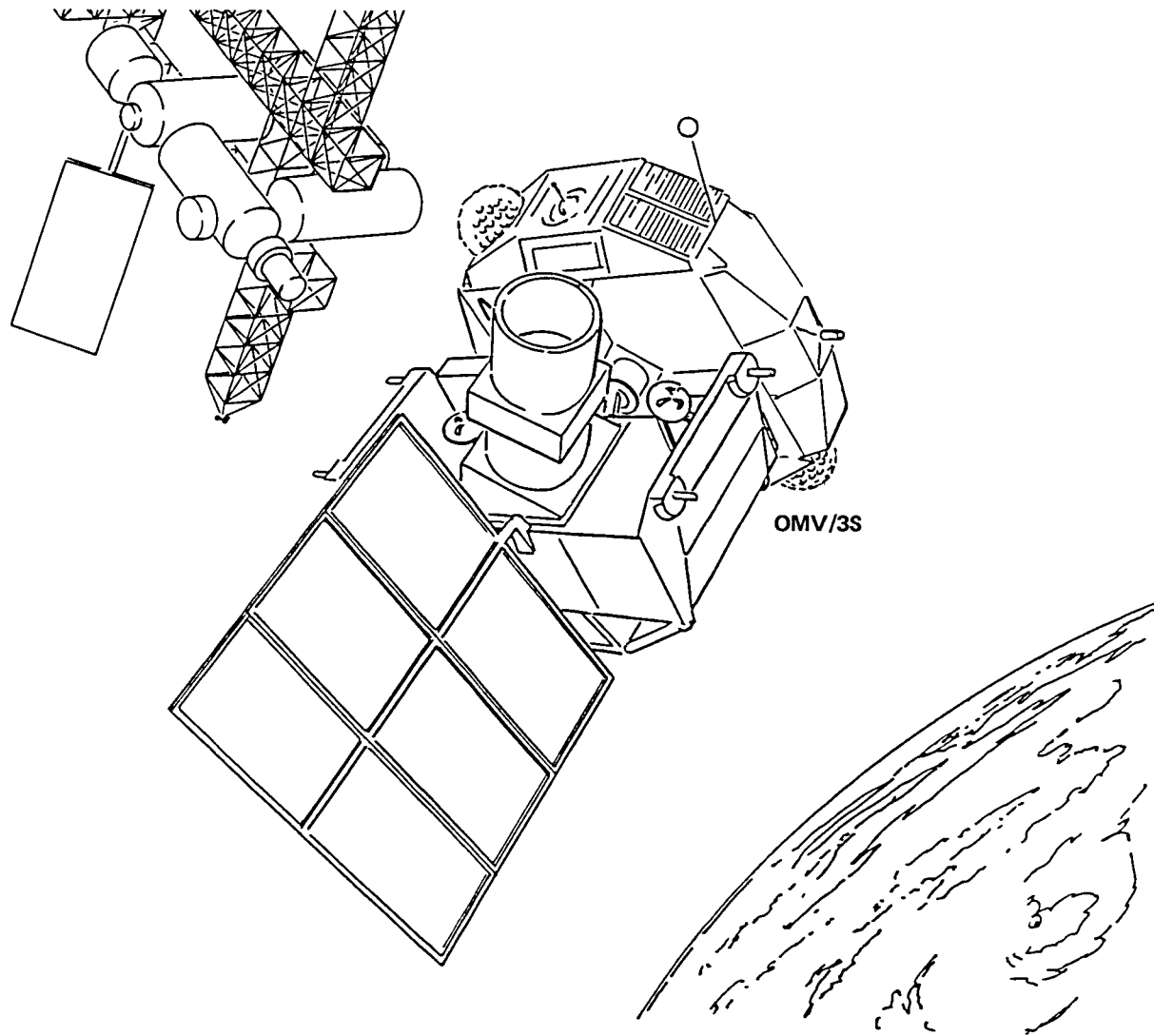

Figure 3-13. OMV with 3S Maneuvers Away from Space Station

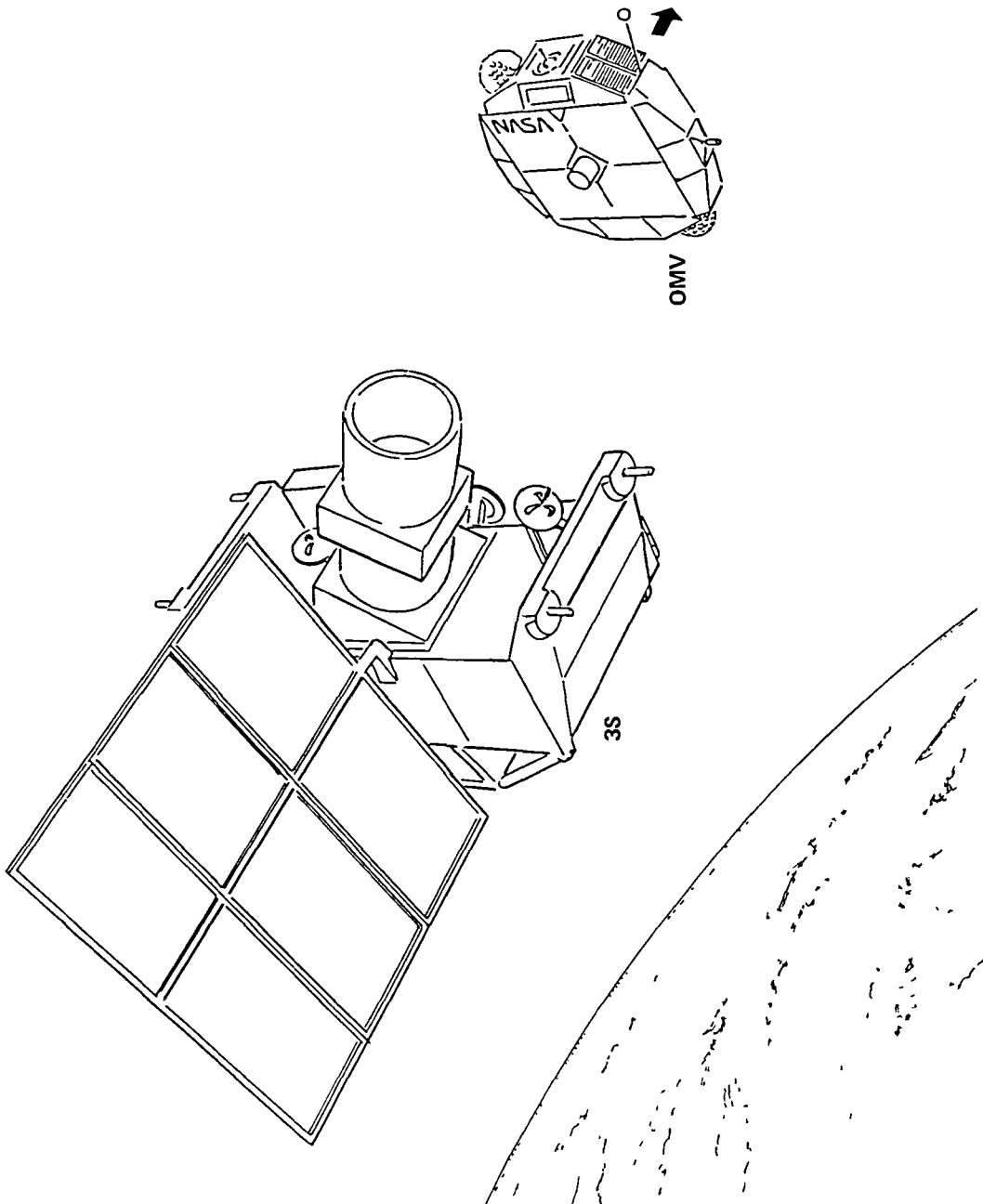

Figure 3-14. OMV Separates from 3S

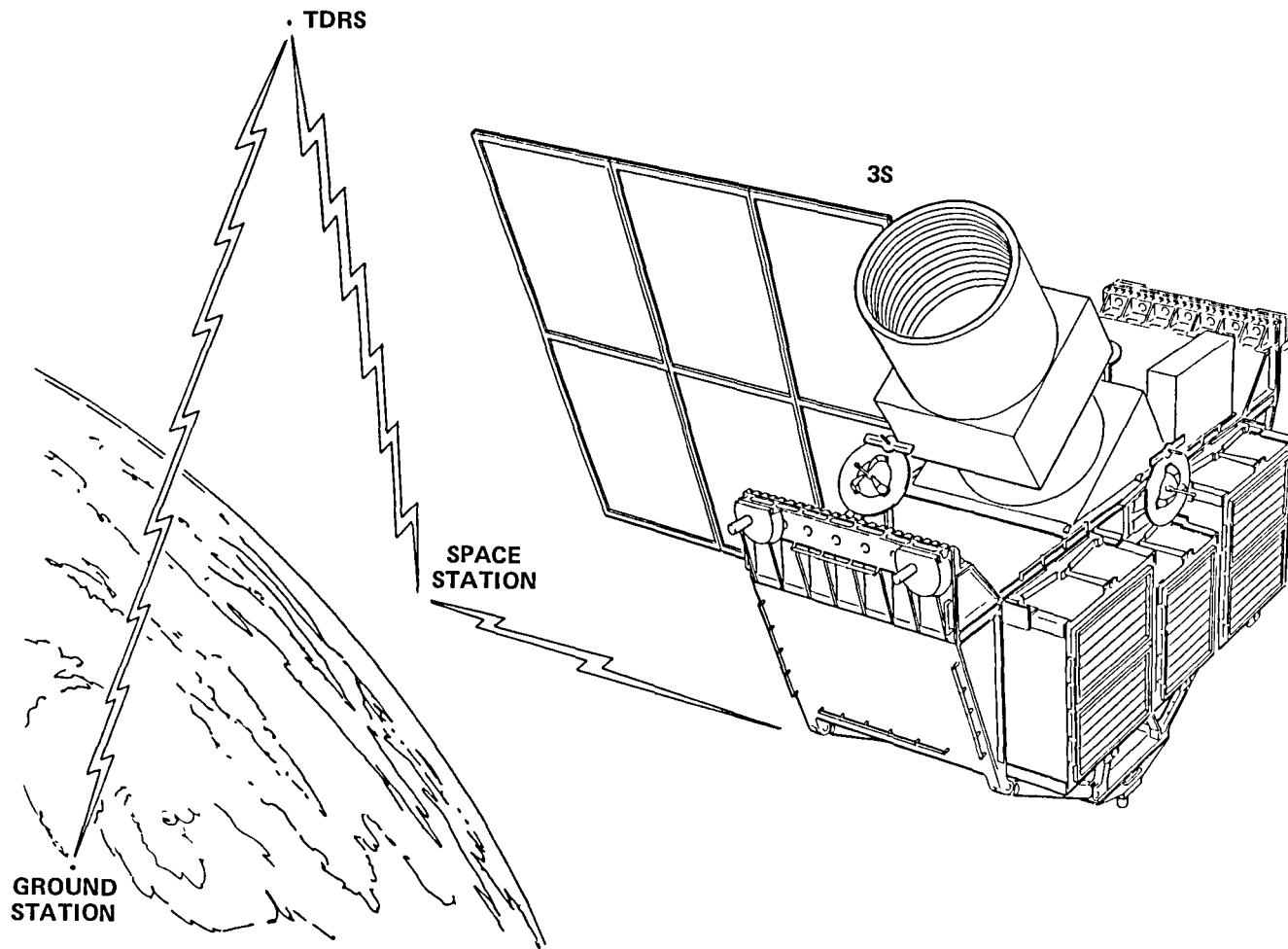

Figure 3-15. 3S Conducts 3 Month Scientific Mission

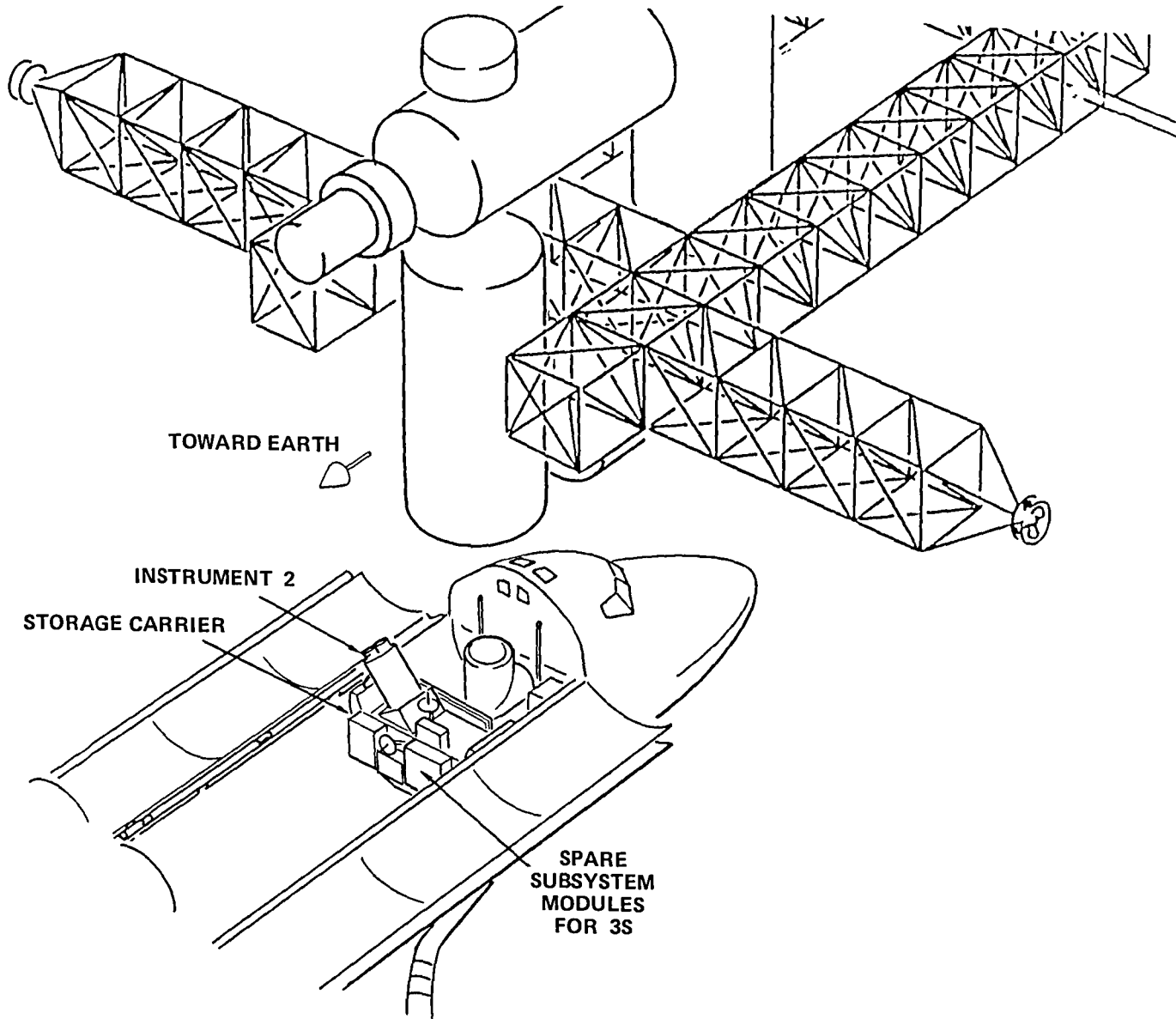

Figure 3-16. 3S Storage Carrier Arrives at Space Station

- Shuttle docks with S/S
- Attach RMS to 3S storage carrier grapple fixture 2
- Disconnect STS umbilical connector
- Open STS trunnion fittings
- Remove 3S storage carrier from cargo bay with RMS
- Attach MRMS to storage carrier grapple fixture 1 or use fixture 3 (on the instrument) if more convenient
- Release RMS from grapple fixture 2
- Move storage carrier to S/S spacecraft storage area with MRMS
- Open spacecraft storage area thermal shroud
- Place 3S storage carrier in storage area (Figure 3-17)
- Clamp 3S storage carrier trunnions
- Release MRMS from grapple fixture 1 (or fixture 3 if used)
- Mate 3S storage carrier electrical connector
- Turn on survival heaters
- Close storage area thermal shroud; instrument and 3S subsystem modules remain in thermally controlled storage area until required for science mission

3.3.2.6 Space Station Spartan Retrieval

- 3S uses hydrazine propulsion system to return to within 20 n.mi. of S/S. Range information will be provided by S/S.
- Deploy OMV
- OMV performs maneuvers to achieve rendezvous with 3S (Figure 3-18)
- 3S is placed in minimum power configuration
- OMV docks with 3S grapple fixture 1 using cold gas
- 3S deactivates appropriate subsystems on receipt of docking signal

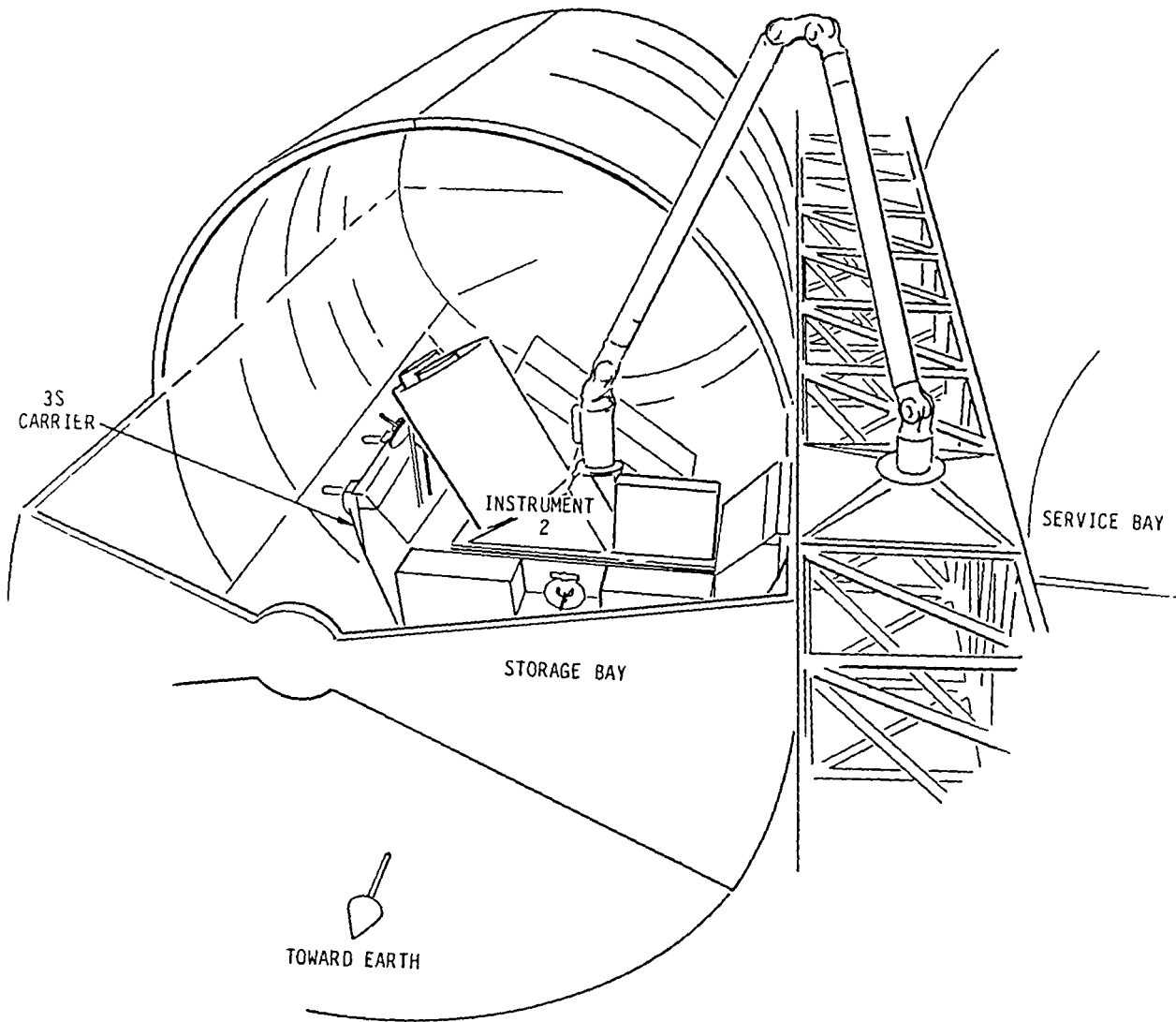

Figure 3-17. 3S Storage Carrier Installed in Storage Bay

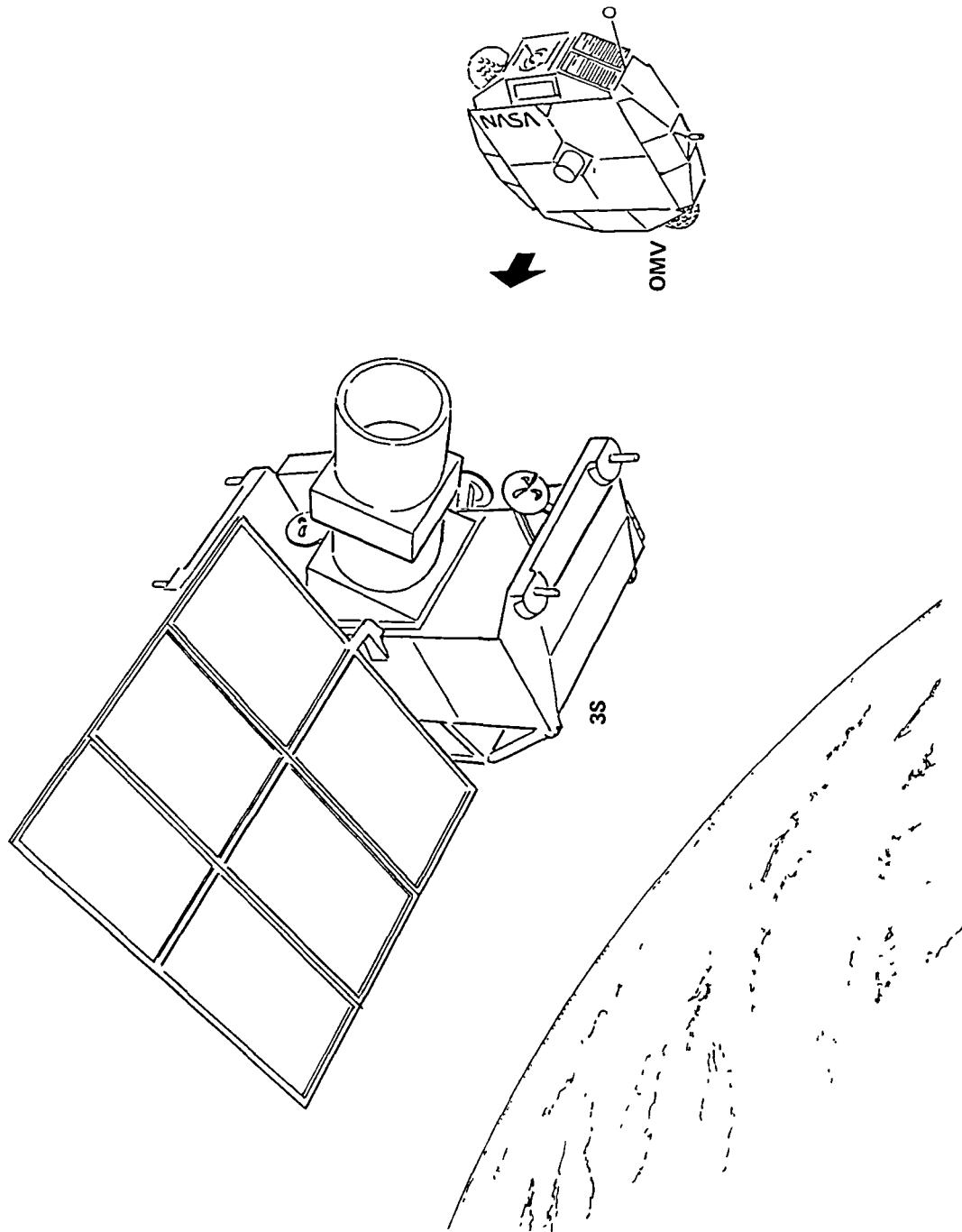

Figure 3-18. OMV Rendezvous with 3S

- OMV with 3S maneuvers toward S/S
- OMV with 3S maneuvers to within 50 feet of S/S using cold gas (Figure 3-19)
- MRMS grapples OMV grapple fixture
- MRMS places OMV/3S carrier in spacecraft service area
- 3S trunnions are clamped
- OMV releases 3S grapple fixture 1 and returns to servicing area
- 3S carrier electrical connector is mated
- 3S carrier is powered off
- Survival heaters are turned on and spacecraft service area shrouds are closed

3.3.2.7 Space Station Spartan Servicing

a. Instrument changeout

- Service bay thermal shroud is opened; EVA 2 begins; EVA crew member places protective covers over 3S thermal louvers
- MRMS grapples instrument 1 using grapple fixture 3
- EVA crew member demates instrument mechanical attachment to 3S carrier
- MRMS removes instrument 1 from 3S with aid of guide rails and EVA crew member (Figure 3-20)
- MRMS moves instrument 1 to storage area
- Storage area thermal shroud is opened
- MRMS and EVA crew members install instrument 1 in temporary storage location (on special bracket) in storage bay
- Release MRMS from instrument 1
- Attach MRMS to instrument 2
- EVA crew member releases and MRMS removes instrument 2 from storage carrier (Figure 3-21)

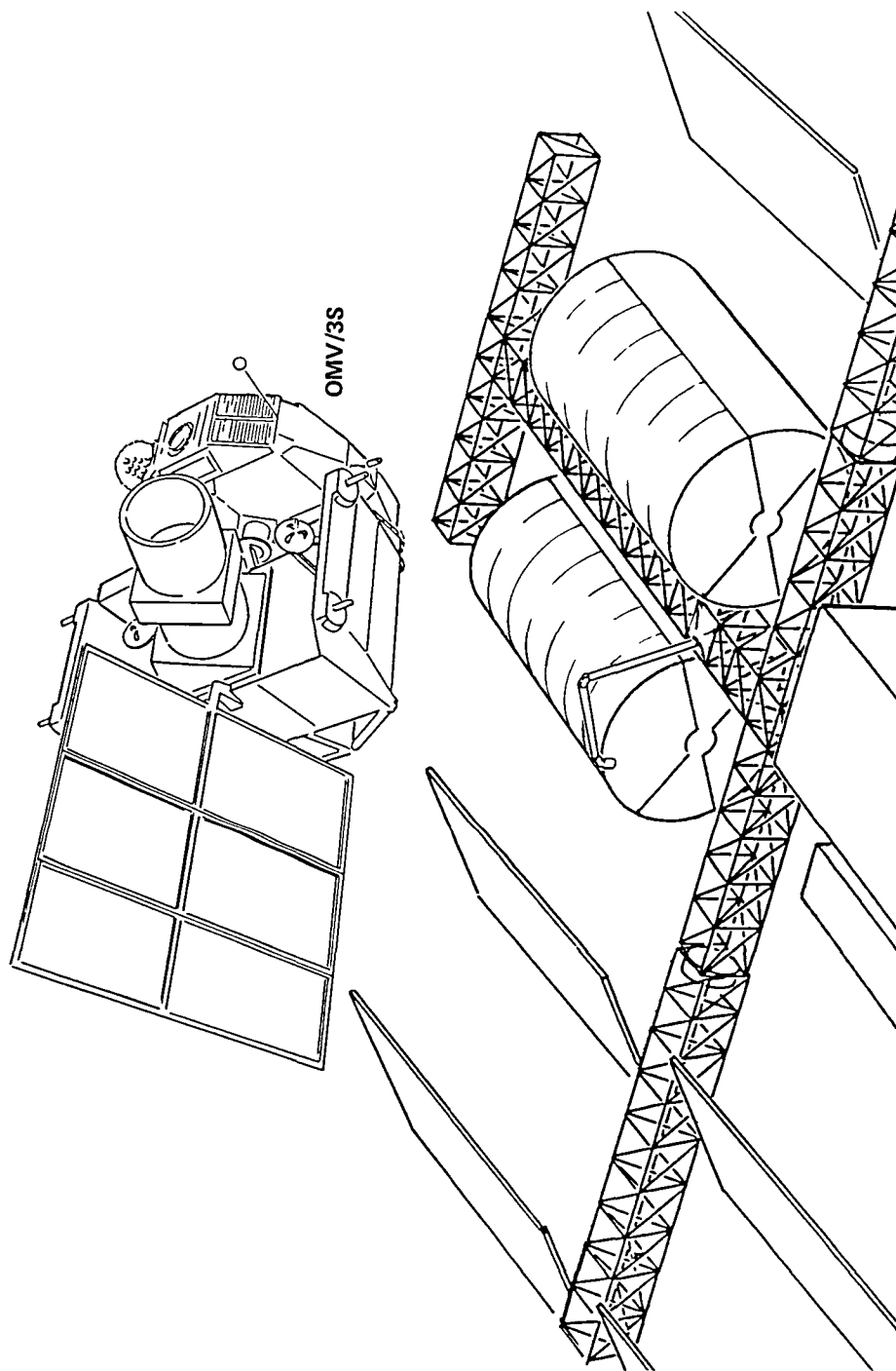

Figure 3-19. OMV/3S Maneuvers for Capture by MRMS

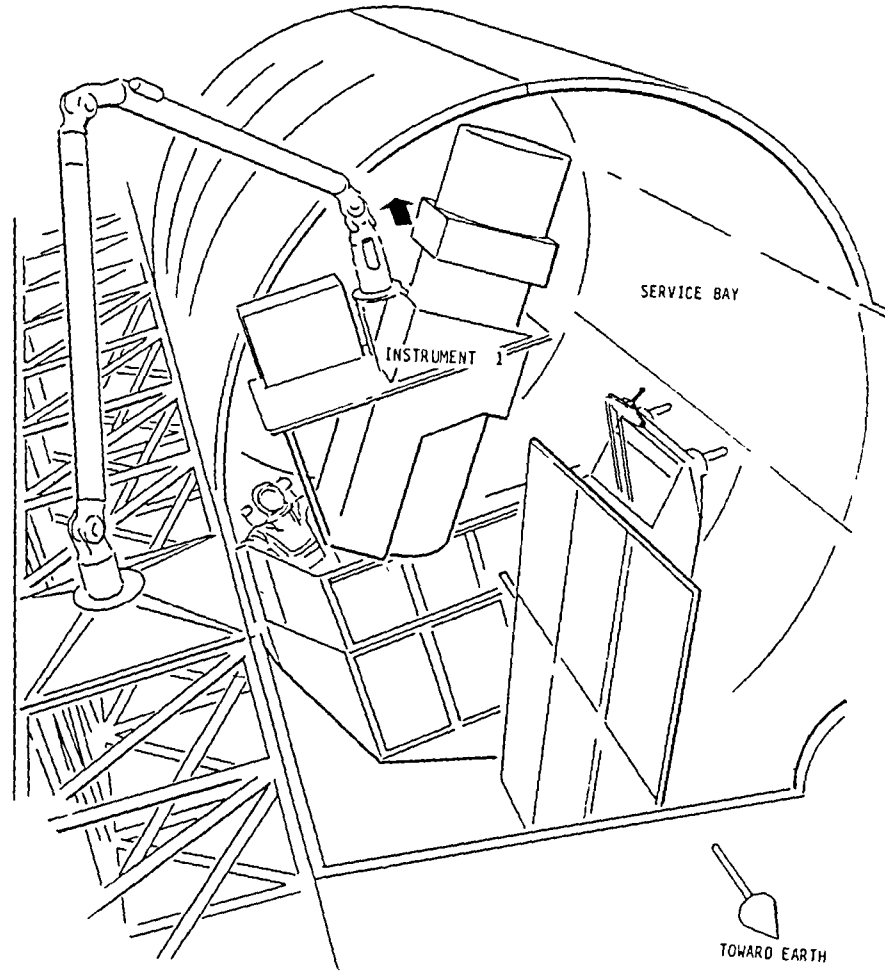

Figure 3-20. Instrument 1 Removed From 3S Carrier

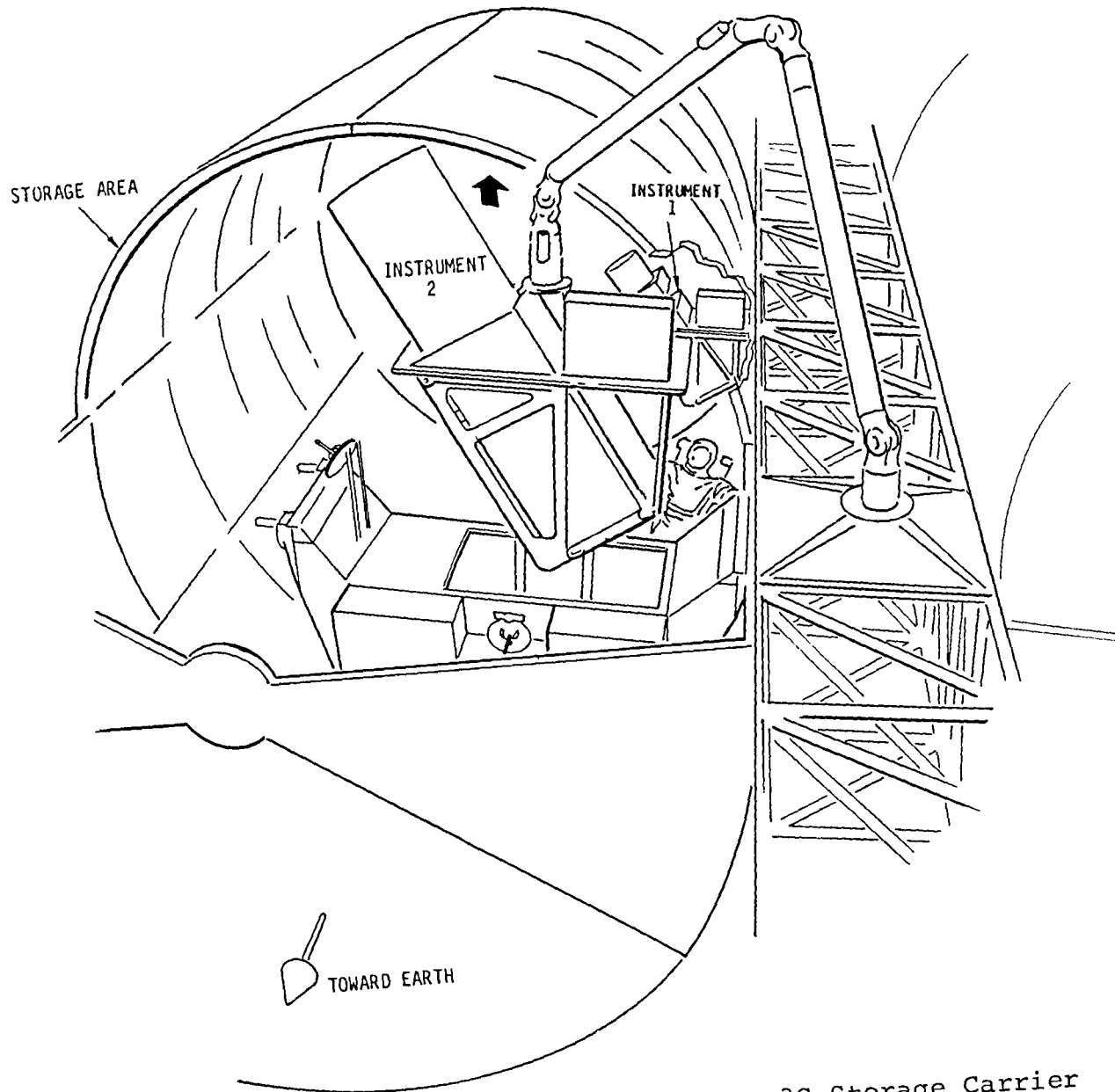

Figure 3-21. Instrument 2 Removed From 3S Storage Carrier

- MRMS moves instrument 2 to spacecraft service area
 - EVA crew member and MRMS install instrument 2 in 3S (Figure 3-22)
 - Disengage MRMS from instrument 2
 - EVA crew member adjusts 3S solar array to correct position for upcoming mission
 - Turn off survival heaters
 - Power up 3S carrier
 - 3S carrier/instrument 2 checkout
 - Move MRMS back to storage area
 - Attach MRMS to instrument 1 (still mounted to special bracket)
 - Remove instrument 1 from temporary storage location
 - Install instrument 1 in 3S storage carrier
 - Disengage MRMS
 - Close storage area thermal enclosure
 - End EVA 2
 - Store instrument 1 for future reuse or return to Earth on next available Shuttle flight
- b. 3S subsystem module replacement
- 3S carrier is powered off
 - 3S carrier survival heaters are turned on
 - Begin EVA 3, EVA crew member places protective cover over subsystem module
 - EVA crew member removes faulty module from 3S carrier with power tool (Figure 3-23)
 - Move faulty module to storage area
 - Open storage area thermal shroud
 - Attach module to temporary storage location (on special bracket)

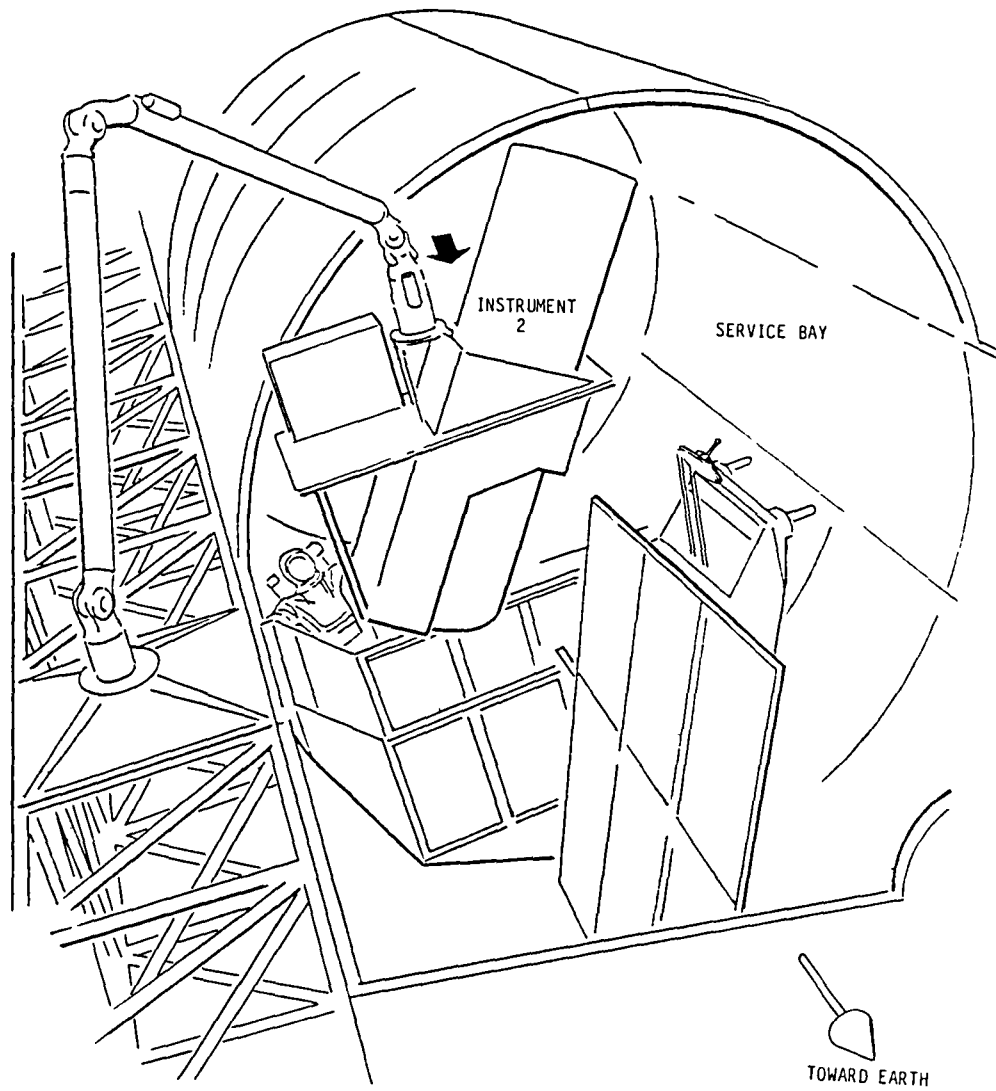
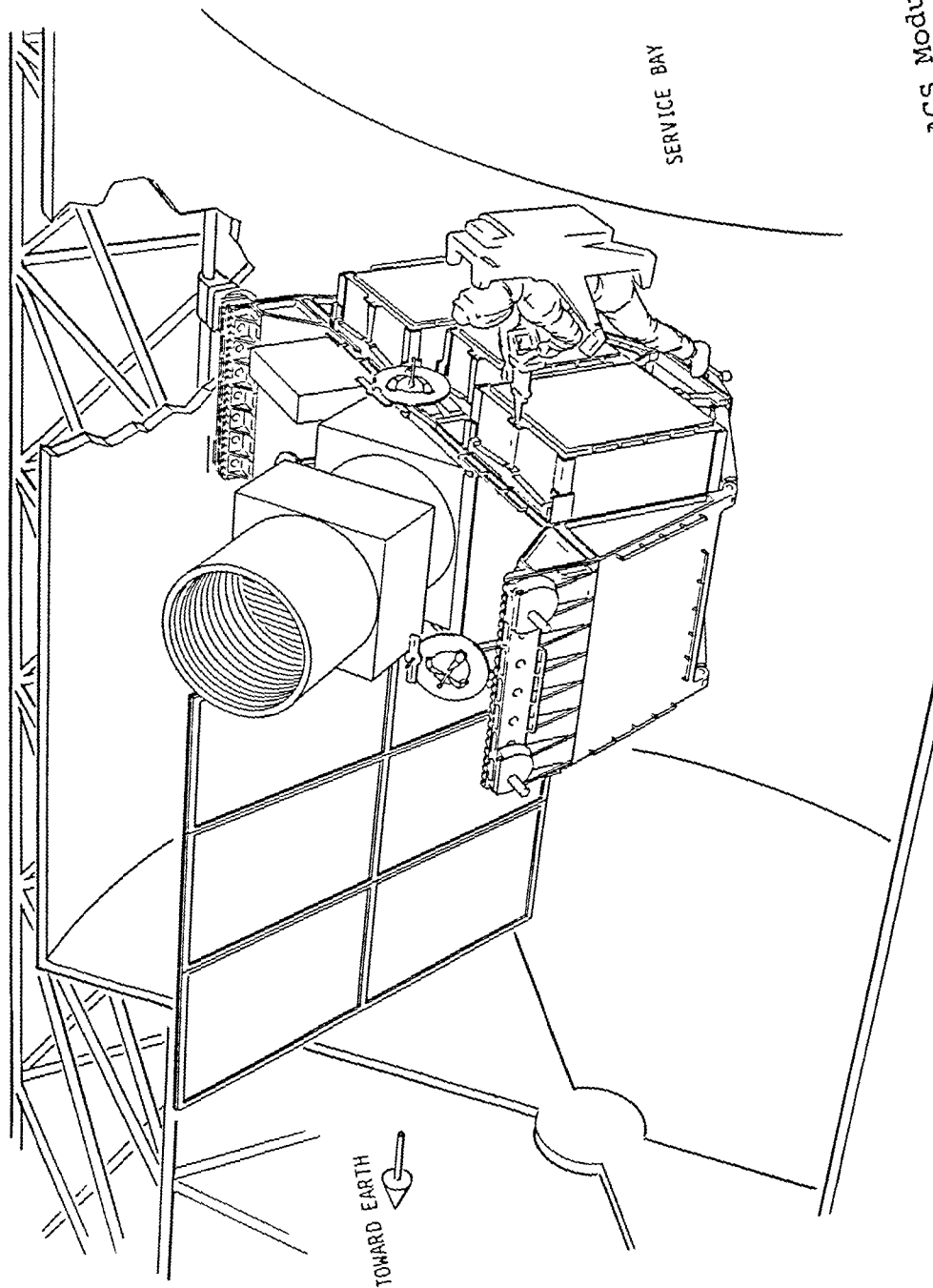

Figure 3-22. Instrument 2 Installed in 3S Carrier



Space Station Crew Member Replaces ACS Module

Figure 3-23.

- Remove replacement module from storage carrier
 - Move replacement module to 3S
 - Attach replacement module to 3S
 - Crew member returns to storage area
 - Remove faulty module from temporary storage location
 - Attach faulty module to storage carrier
 - Close storage area thermal shroud
 - End EVA 3
 - Store faulty module for return to Earth on next available Shuttle flight (or repair on orbit if possible)
 - Power up 3S carrier
 - Conduct 3S carrier checkout
- . Propulsion system refueling
- 3S carrier is powered off
 - Begin EVA 4
 - MRMS grapples 3S using grapple fixture 1
 - Demate 3S carrier electrical connector
 - Release 3S carrier trunnions
 - MRMS moves 3S carrier to refueling bay
 - Place 3S carrier in refueling bay
 - Clamp 3S carrier trunnions
 - Demate MRMS from 3S carrier
 - Mate 3S carrier electrical connector
 - Turn on 3S survival heaters
 - Remotely mate propellant line quick disconnect
 - Refuel 3S propellant tanks to specified level using TBD procedure (Figure 3-24)

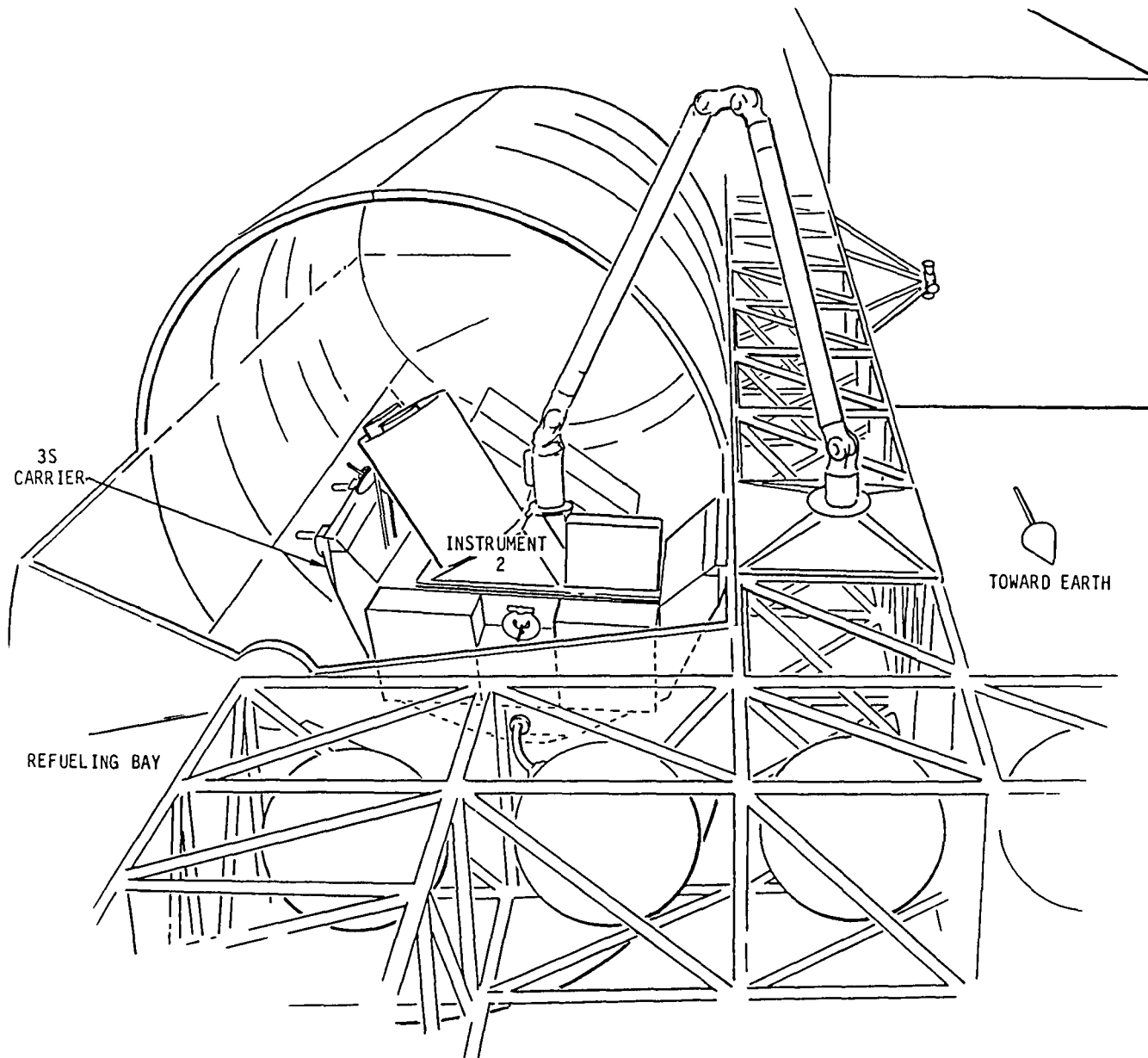

Figure 3-24. 3S Hydrazine Propulsion Subsystem is Refueled

- Remotely demate propellant line quick disconnect
- Attach MRMS to 3S grapple fixture 1
- Turn off survival heaters
- Demate 3S carrier electrical connector
- Release 3S carrier trunnions
- MRMS move 3S carrier to spacecraft servicing area
- Place 3S carrier in spacecraft service bay
- Clamp 3S carrier trunnions
- Release MRMS from grapple fixture 1
- Mate 3S carrier electrical connector
- Power up 3S carrier
- End of EVA 4
- GSFC POCC conducts 3S checkout through S/S-TDRSS

3.3.2.8 Return Mission (Flown Instrument and Any Faulty Space Station Spartan Modules are returned to Earth in Transport Carrier)

- Start EVA 5
- Open storage area thermal shroud where flown instrument is bolted into 3S storage carrier
- Attach MRMS to flown instrument grapple fixture (3)
- EVA crew member mechanically disconnects flown instrument from 3S storage carrier
- MRMS moves flown instrument out of storage area
- Storage area thermal shroud closed
- MRMS moves flown instrument to vicinity of Shuttle
- MRMS places flown instrument in 3S transport carrier in Orbiter cargo bay
- EVA crew member mechanically attaches flown instrument into 3S transport carrier

- EVA 5 ends
- Orbiter is demated from S/S
- Orbiter returns flown instrument to Earth in 3S transport carrier

See Appendix D for a preliminary timeline for the 3S mission scenario. Note that the turnaround time between two 3S science missions may be as short as a few days (assuming necessary S/S support coincides with a suitable science window).

4. SPACE STATION SPARTAN SCIENCE

4.1 POTENTIAL USERS OF SPACE STATION SPARTAN

Communities of 3S users can be identified depending on the capability of the ACS that is provided. Three levels of ACS performance have been considered. In each, the pointing capability is determined by the design and the selection of subsystems and components. The three major categories in order of increasing capability are as follows:

- (1) Current (Orbiter-deployed) Spartan ACS capability with extension to 1 to 3 month mission duration (configuration 1, the basic 3S ACS).
 - 2 arc-min pointing accuracy
 - 10 arc-sec peak-to-peak jitter
 - 1.8 arc-min/hour drift
- (2) Current Spartan ACS capability with addition of reaction wheels and including 1 to 3 month mission duration (configuration 2).
 - 2 arc-min pointing accuracy
 - 1 arc-sec peak-to-peak jitter
 - 1.8 arc-min/hour drift
- (3) MMS type ACS (configuration 3 or strawman 3S ACS)
 - 0.5 arc-min absolute pointing accuracy
 - 1 arc-sec peak-to-peak jitter
 - 0.18 arc-min/hour drift

The design of these ACS's is discussed in Section 5.6.

4.1.1 Potential Users of a Basic Space Station Spartan Attitude Control System

The basic 3S ACS will serve current users of STS/Spartan who would benefit from the longer observing times provided by 3S. In particular, 3S offers low-resolution astronomical payloads the ability to view targets for longer periods of time to record brightness fluctuations or to build up accuracy in measuring faint sources. Several of the astronomy (ultraviolet (UV), extreme ultraviolet (EUV) and soft X-ray) payloads recently proposed for 40-hour long

STS/Spartan flights will be in this category. In addition to low-resolution observations, the opportunity will benefit users who use image motion compensation systems in their instruments (not addressed by current Spartan proposers) or who read out data, particularly images, very rapidly and apply image reconstruction techniques to compensate for drift and low-frequency jitter during postflight data processing.

Solar physics payloads currently selected for STS/Spartan can use a 1-month to 3-month mission to view the solar corona as it rotates at a 27-day rate. At present, these payloads (coronagraphs and EUV spectrometer) also have potential for very long duration flight opportunities on the Solar and Heliospheric Observatory (SOHO) being considered by the European Space Agency (ESA) which may make a 1 to 3 month 3S mission less attractive. The requirements of current state-of-the-art solar imaging experiments (1 to 2 arc-sec spatial resolution) on sounding rockets are incompatible with the capability (10 arc-sec p-p jitter) of the basic 3S ACS. Other solar physics instruments such as the high energy X-ray and gamma-ray spectrometers, which do not have fine-pointing requirements, may also be considered for 3S. In the past, these nonimaging instruments have been developed as balloon payloads rather than sounding rocket payloads because of their large size and high mass.

4.1.2 Potential Users of an Upgraded Space Station Spartan Attitude Control System

To expand the 3S user base of fine-pointed experiments, the current ACS can be upgraded to improve its high-frequency jitter characteristics, its low-frequency drift, or both of these properties. Of these two options, improvement in jitter performance, by adding reaction wheels that reduce high-frequency jitter to the 1 to 2 arc-sec peak-to-peak level without expending propellant, is most likely to expand the user base. This option qualifies the 3S as a feasible flight opportunity for fine-pointed solar payloads such as high resolution X-ray telescopes and the UV and EUV spectroheliographs. The primary science products of these instruments are solar images at high spatial resolution (1 to 2 arc-sec) and varying levels of spectral discrimination. Because the instruments carry Sun sensors that provide correction signals to the ACS and keep it locked on the Sun, the lack of an ACS with a low-drift rate is not a problem. In addition, an upgraded 3S ACS will be able to accommodate astronomical UV and EUV payloads that have internal star trackers for target acquisition and tracking. 3S then will accommodate X-ray astronomy payloads that require low jitter but have relatively wide fields of view. With this level of ACS capability, an astronomical target will slowly drift through the field of view of the instrument but will provide usable science data.

4.1.3 Potential Users of a High Performance Attitude Control System

The capability of a top performance ACS, such as that provided to the Solar Maximum Mission (SMM) spacecraft with high-performance gyros, star trackers, and reaction wheels, will provide 1 arc-sec peak-to-peak jitter and 0.1 arc-min/hour drift rate. This capability will enable a sophisticated instrument such as the HUT to be accommodated without modifying its existing target acquisition and tracking system and without adding internal motion compensation systems. This category of users also includes the Ultraviolet Imaging Telescope (UIT), which uses an auxiliary tracking system but requires low ACS jitter and drift to achieve the desired performance level.

4.2 DEVELOPMENT OF STRAWMAN SCIENCE REQUIREMENTS

Because of the short duration of this study, it was impossible to address the requirements of all the disciplines that might use a 3S. The diverse operational requirements that the different disciplines impose suggest that at least two payloads be considered in this study. This approach would identify requirements for reconfiguring the carrier between missions and would identify support services from the S/S during this activity.

The degree of sophistication and the operational requirements of a strawman payload were also an issue. Clearly, payloads with relatively simple interfaces and operational requirements, such as many of the experiment proposals recently submitted to NASA Headquarters in response to a letter addressing potential Spartan flight opportunities from the Orbiter, could be identified and could be among the earliest 3S payloads flown. These payloads, however, would not define the level of S/S operations and servicing later payloads would require. When defining the needed characteristics of a S/S that would be in place for many years, a payload reflecting the mature phase of a 3S was considered more appropriate.

On the other hand, it was desirable to study a payload with interfaces and operations requirements already well developed. After consultation with NASA Headquarters, the HUT currently being developed for a Spacelab mission was selected as the primary strawman payload. This instrument, derived from the Aries class sounding rocket payload, has the heritage that the original Spartan program intended to serve. The HUT also has well-documented interface requirements that the 3S study team could easily adopt as experiment requirements for a 3S payload.

A corresponding payload was not available from an operationally different discipline such as solar physics. Consequently, a hypothetical group of five instruments all designed to study some aspect of the same object--the solar corona--was assembled using

previous NASA studies of solar coronal explorer payloads as guides. The selected instrument assembly consisted of two coronagraphs to be flown on Spartan 201 US supplemented by two instruments developed under the rocket program--an EUV spectrometer and X-ray telescope--and a solar magnetograph originally conceived for the International Solar - Polar (Ulysses) Mission. Interface requirements were derived from existing NASA documents but no attempt was made to confirm their validity, because the second hypothetical 3S mission did not appear to drive the design of the carrier except in the area of data transmission rates.

4.2.1 Strawman Instrument Descriptions and Requirements

The primary strawman payload for this study, the HUT, is a 1 meter class telescope designed to observe the far UV and EUV radiation of astronomical objects. A schematic view of the optical system is shown in Figure 4-1. A 90-centimeter diameter paraboloidal mirror focuses radiation onto one of several selectable entrance apertures to a Rowland spectrograph. In the first order mode, the spectral range of the spectrograph is from 850 to 1850 angstroms with a dispersion of 1 angstrom per detector channel. In the second order mode, the effective spectral range is from 425 to 700 angstroms with an aluminum filter being used to reject the first order spectrum. The UV sensors within the spectrograph are required to be under high vacuum at all times. To satisfy this requirement, a 2 liter per second vacuum pump (an ion pump) is permanently attached to the spectrometer enclosure. A firm requirement of this system is that power may not be cut off for more than 3 hours at a time. After this time the pressure within the spectrograph may rise to 10^{-4} torr which could cause the ion pump to not restart when power is reapplied and an external pump-down procedure to be required. Once the instrument is in orbit, removal of electrical power from the pump is not critical because exposure of the spectrograph to the space environment will maintain its pressure below 10^{-4} torr.

A silicon intensifier target television camera, external to the Rowland spectrograph, views the entrance aperture and allows the focal plane images to be monitored by the experiment operations team. These focal plane images provide a means for acquiring targets and for measuring the pointing error of the telescope. Acquisition of the desired target is accomplished by recognizing a pattern of guide stars in the 9 by 12 arc-min field of view of the focal plane monitor and by calculating the change in pointing direction to bring the desired target into the entrance aperture of the spectrograph. This determination can be performed by an observer on the ground or in space or automatically by the instrument's computer, if the acquisition star field is uncomplicated and the telescope is pointed within a 30 arc-sec of the desired line of sight. The system is designed to provide a focal

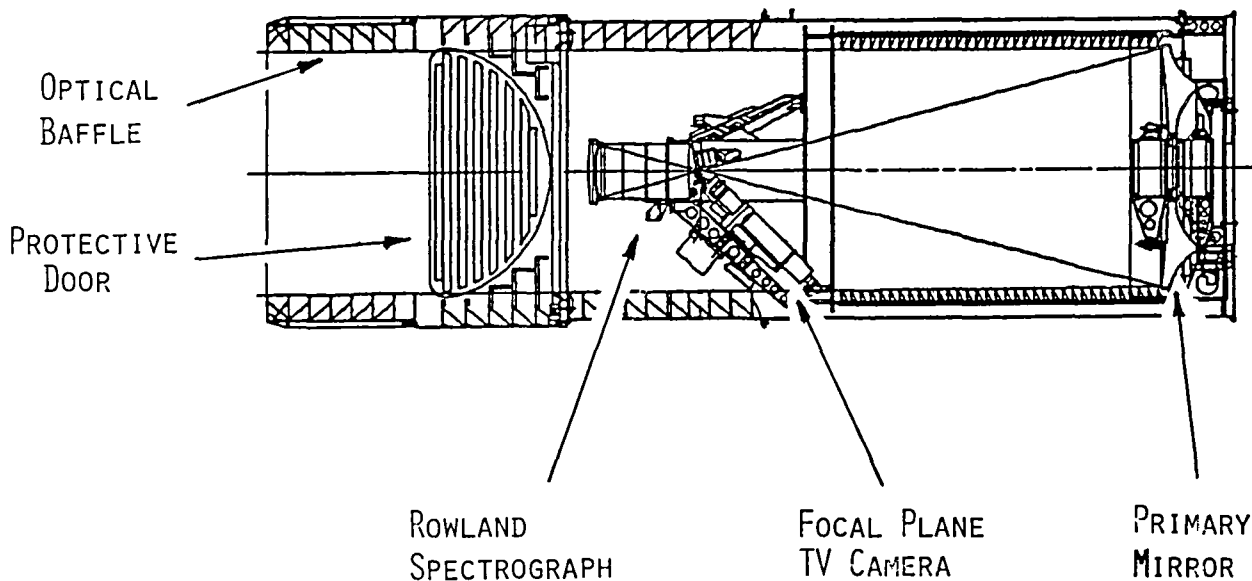

Figure 4-1. Optical System for Hopkins Ultraviolet Telescope Strawman Payload

plane image to the observer every 20 seconds, but this rate, which is not critical, can be modified to be compatible with available downlink telemetry rates.

Figure 4-2 is an artist's concept of a possible configuration for the group of solar instruments. The three 17-inch diameter instrument enclosures reflect the original design of the sounding rocket instruments. This figure shows how the instruments may be accommodated in an Aries-size envelope, although payloads flown on 3S are not required to have a circular outline. The intent is merely to show that an alternate payload to the HUT, with the same external dimensions, could be identified and used for evaluating payload changeout procedures in space.

Experiment parameters and requirements used in this study are summarized in Tables 4-1 through 4-5. Little effort was made to define requirements for the secondary payload, because the accommodations and services already provided to the primary payload appeared adequate.

4.3 SCIENCE OPERATIONS FOR THE STRAWMAN INSTRUMENTS

An effort was made to define the interactive science operations required for the HUT. Because an in-orbit payload specialist

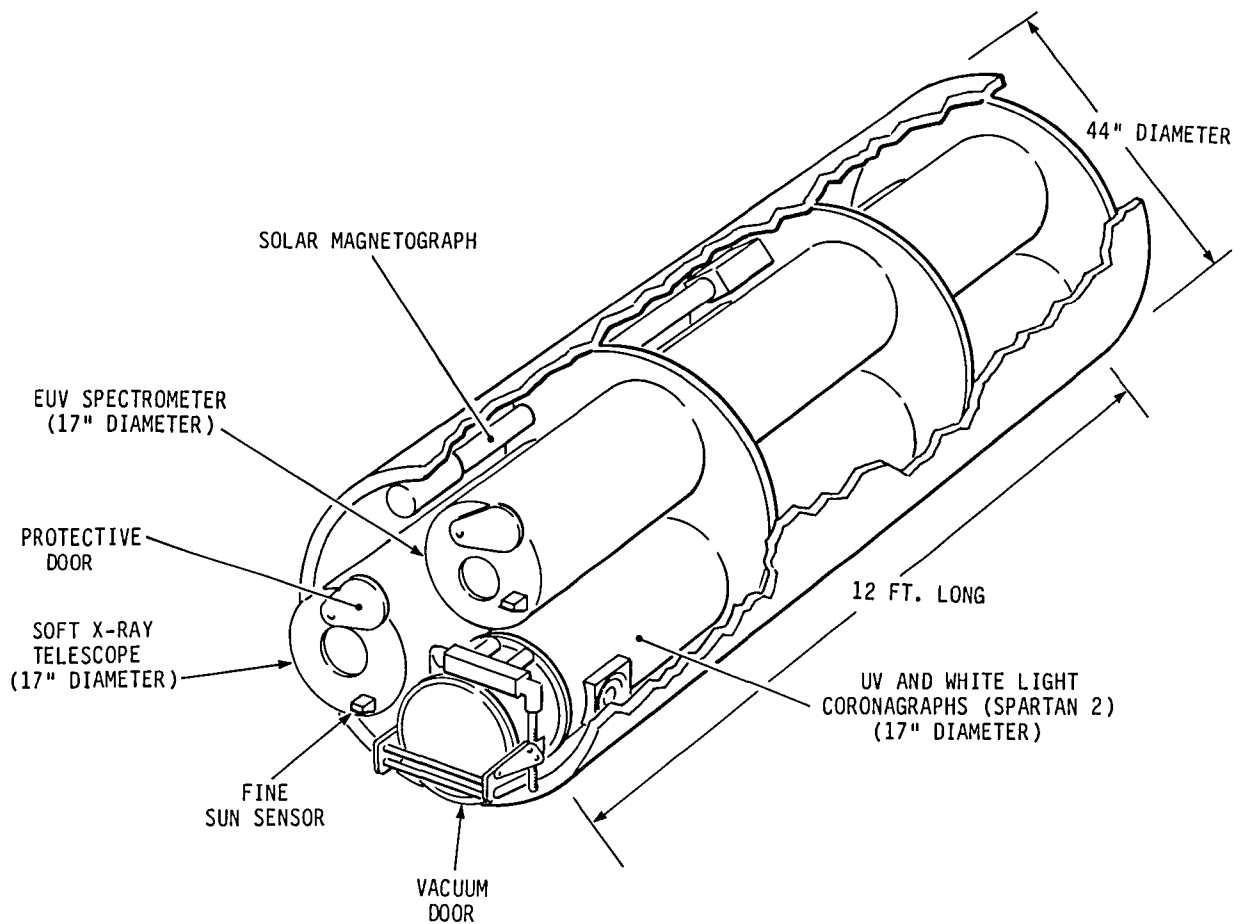

Figure 4-2. Possible Configuration for Solar Physics Cluster Strawman Payload

would not be available, as during flight of the Spacelab, an appreciably different science operations scenario that depended much more heavily on data and command links to the ground had to be defined. The following assumptions were made when developing the hypothetical operations scenarios:

- Long duration (up to 10,000 seconds cumulative) observations would form the bulk of the observing schedule.
- No repointing to a different scientific target during Earth occultation of the first target or because of changing Sun illumination (i.e., no bright side/dark side target switching). These intervals may be used to update the onboard gyros.

Table 4-1
Physical Parameters of Strawman Payloads

	Stellar (HUT)	Solar (Solar Corona Studies)
Telescope module size	146-inch long by 43-inch diameter	118-inch long by 43-inch diameter
Mass		
Telescope module	1550 lbs	882 lbs
Electronics module	120 lbs	220 lbs
Cables, Miscellaneous and Contingency	250 lbs	78 lbs
Total	1920 lbs	1180 lbs
Power	163 W, electronics 147 W, heaters	212 W*
	24 <u>+4</u> V	TBD

*Plus power for thermal control

Table 4-2
Environmental Constraints

	Stellar (HUT)	Solar (Solar Corona Studies)
Temperature range	0 to 20°C, operating (prefer operating at less than 10°C) 0 to 40°C, nonoperating	TBD
Prelaunch humidity	<50% relative humidity (using continuous purge)	TBD
Prelaunch hydrocarbon , level	<15 ppm (to avoid UV degradation; will be achieved using purge)	TBD

Table 4-3
Pointing Requirements

	Stellar (HUT)	Solar (Solar Corona Studies)
Open loop pointing accuracy	30 arc-sec	30 arc-sec
Closed loop accuracy	Capable of using experiment-provided error signal	Capable of using experiment-provided error signal
Pointing maneuvers	Multiple stellar targets with avoidance of Sun, Moon, and bright Earth during repointing	Offset pointing from Sun center ($\pm 2^\circ$)
	Entire sky (subject to avoidance constraints) should be available	Roll control around Sun center
Jitter	1 arc-sec	2 arc-sec
Dwell time on a target	Up to 10,000 sec cumulative	TBD

Table 4-4
Data and Command Requirements

	Stellar (HUT)	Solar (Solar Corona Studies)
Science data	20 kbps	55 kbps minimum 155 kbps desirable
Real-time downlink during target acquisition	82 kbps	TBD
Estimated data rates for future imaging experiments	200 kbps	200 kbps
Initial up-link command load (once at beginning of mission)	40,000 16-bit words to load HUT memory	TBD
Routine observations	50 commands for each HUT observational sequence before initiation of sequence	TBD

Table 4-5
 Science Operations Requirements

	Stellar (HUT)	Solar (Solar Corona Studies)
Interactive control of payload for target selection or verification	Six contacts per 24-hr day, each contact approximately 20- min long	TBD
Mission duration	3-month mission desirable	3-month mission desirable 1-month mission acceptable

- Astronomical targets will be selected and an operating timeline developed for 1 month of operations before deployment of the mission; however, targets of opportunity such as comets or novae can be accommodated.
- All quick look science data displays, analysis, and instrument command generation will be provided by experiment GSE.

Figures 4-3 and 4-4 show two hypothetical timelines for target acquisition. Figure 4-3 addresses the case in which the initial pointing maneuver by the 3S ACS leaves the HUT optical axis offset by more than 30 arc-sec from the desired line of sight. Figure 4-4 shows a timeline when this error is less than 30 arc-sec. In these figures, time runs from left to right and the upper four horizontal bars represent the timelines for the experiment, the 3S ACS, the GSE for the carrier, and the GSE for the experiment. The pointing verification procedure that must be satisfied at each step of the target acquisition sequence is entered under these timelines. The heavy vertical arrows show the flow of control functions from one system to another during the acquisition sequence.

As the scenario begins, the science instrument is just completing observations of an astronomical object. When the observational sequence is ended, an appropriate signal is sent from the instrument to the 3S ACS. The 3S ACS then reorients the spacecraft and the experiment's line of sight to the next target, which has the coordinates and the required sequence of ACS maneuvers already stored in an onboard computer. After this maneuver, the minimum pointing requirement for the new target is that the preselected guide stars be within the 9 by 12 arc-min field of view of the HUT television acquisition camera.

At this point, the 3S is held in a stand-by mode waiting for a direct command and data link to the ground through the S/S. When this link becomes available, an image from the HUT television acquisition camera is transmitted to the 3S ground station and sent to the experiment GSE for display and evaluation. The experiment ground operations team verifies that the guide stars are in the field of view and calculates the necessary ACS offset to bring the target to the entrance aperture of the HUT spectrograph. During this activity, commands used to configure the HUT for the upcoming set of observations (i.e., slit, filter, and wavelength selection) are uplinked to the instrument through the S/S.

When the television camera data are evaluated, in about 5 minutes, the instrument team will specify an ACS offset which should bring the target into the observing aperture of the HUT. Appropriate commands are transmitted to the 3S by the S/S and executed. If the correction is precisely accurate, the target will be acquired by the HUT. Subsequent to the ACS maneuver, another television

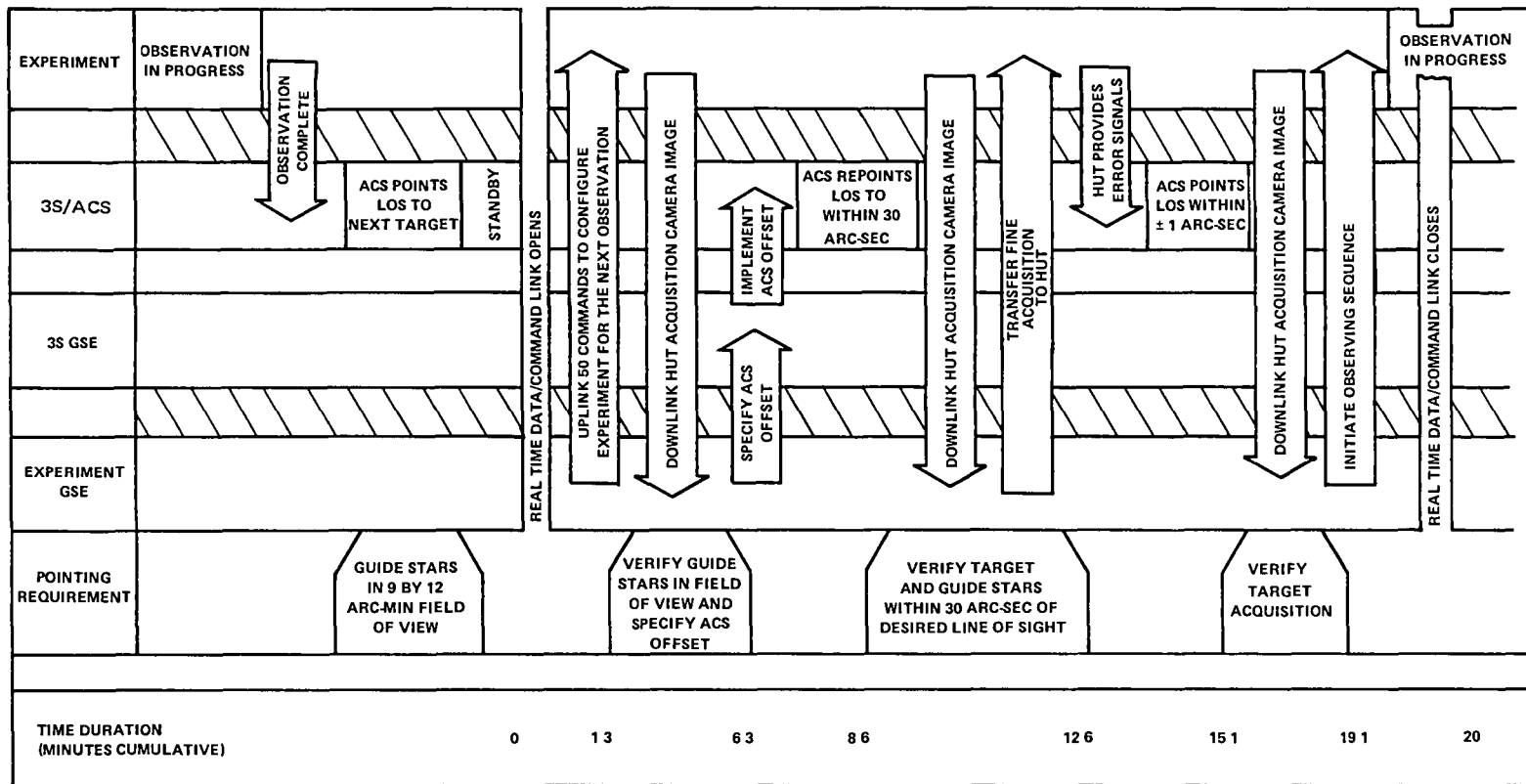

Figure 4-3. Typical Target Acquisition Sequence for a 3S Astronomy Payload

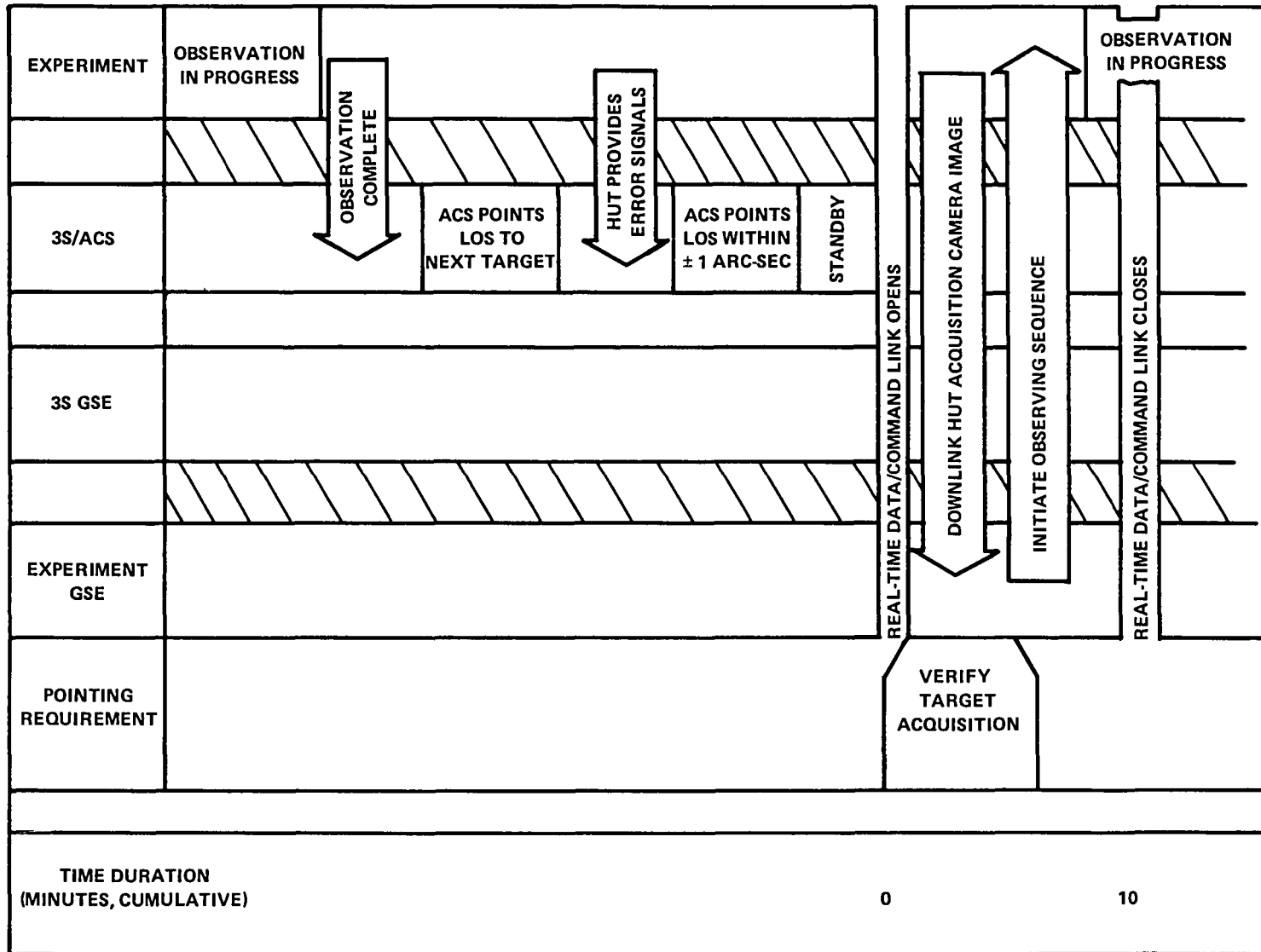

Figure 4-4. Automated Target Acquisition Sequence for a 3S Astronomy Payload

image is transmitted to confirm that the target is at least within 30 arc-sec of the spectrograph aperture. When the target is verified by the ground controllers, the final acquisition and continued tracking of the object for the duration of the observation will be turned over to the HUT computer. This computer will continuously update and provide error signals to the ACS to maintain the target within 1 arc-sec during the observation. When the transfer of control authority is confirmed at the control center a command will be sent to begin the science data acquisition. Real-time command and data links will then not be required until the next target acquisition cycle begins.

If the accuracy of the ACS including the star trackers is adequate, and the alignment of the experiment's line of sight to the ACS is sufficiently stable and calibrated after deployment, the target acquisition sequence shown in Figure 4-3 may possibly be truncated. For the HUT, target acquisition can be performed using only signals from the HUT computer if the target is within 30 arc-sec of the spectrograph aperture and if the surrounding star field containing the guide stars is sufficiently simple. The resulting acquisition sequence, shown in Figure 4-4, is not likely to become routine, but it may be useful for especially bright targets or simple star fields.

5. SPACE STATION SPARTAN SUBSYSTEMS DESCRIPTION

5.1 SPACE STATION SPARTAN MECHANICAL SUBSYSTEMS

5.1.1 Space Station Spartan Carrier Structure

The same basic structure is used for the 3S flight carrier, the 3S storage carrier, and the 3S transport carrier. Each 3S carrier consists of two major structural subassemblies: the primary support structure and the science payload interface structure. The standardized mechanical and electrical interface between these two subassemblies provides the basis for the interchange of science payload systems with relative ease at the S/S and also, if desired, in the STS Orbiter bay. The primary support structure supports all subsystems of the 3S and together with them, comprises the 3S carrier system. All components of the science payload (instruments and electronics) are attached in turn to the science payload interface structure and as such, comprise the science payload system which attaches at the aforementioned fixed interface by means of six attachment fittings. The relationship of these components is illustrated in Figure 2-1.

5.1.1.1 Primary Support Structure--The primary support structure is derived from a drop center box Spartan flight support structure (SFSS). The SFSS was conceived and proposed in the current Spartan/STS program as a bridge structure attached in the Orbiter bay to support Spartan 100 and 200 class spacecraft via a release-engage mechanism (REM).

The proposed drop center box SFSS is shown in combination with Spartan 201, the REM, and four GAS payloads in Figure 5-1.

Currently, the SFSS function is being accomplished using a generic mission peculiar equipment (MPE) support structure (MPESS) and MPE combination to support the REM. Preliminary design and analysis indicates that for the same weight as the MPESS/MPE and the same required STS Orbiter bay (X direction) length (dictated by the REM) the proposed aluminum support structure will provide a significant increase in strength and stiffness and thus higher load capacity, structural margins, and natural frequency. This latter characteristic will reduce the coupled loads with the Orbiter. The principal reason for these superior characteristics is the basic design. Instead of a truss type structure that is characteristic of the MPESS and most other "across-the-bay" support structures, the drop center box is basically a central closed box (60 by 128 by 48 inches) of semimonocoque construction. This design, which makes the most efficient use of the structural material by placing it at the extremes of the structural envelope, also frees up the interior of the structure for internal stores. This last feature is not important to the primary purpose of the structure, which is to support the REM and the Spartan 100 and

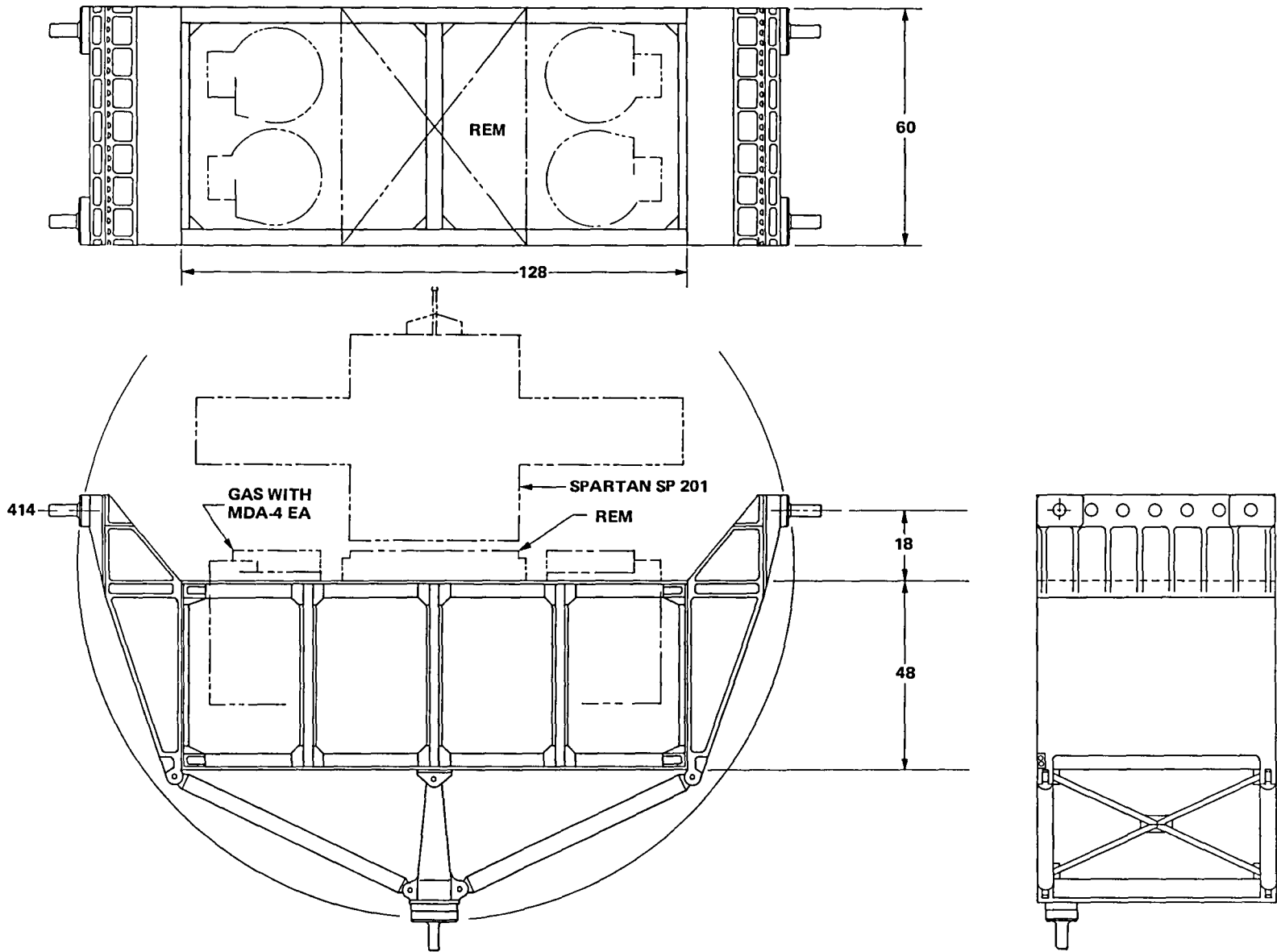

Figure 5-1. Spartan Flight Support Structure Proposed for Spartan/STS, Orthographic View (dimensions in inches)

200 carriers on its upper surface. However, it does allow this same basic structure to internally accommodate GAS containers, or with minor modifications to be used as a carrier for large Aries class telescopes such as HUT. Therefore, the drop center box SFSS, with modifications, is being used as the primary support structure for this 3S study.

The unmodified central box is constructed of four 128-inches long longerons as the principal edges of the box. Shear loads between the longerons are carried by either thin semitension field webs or more likely light-weight honeycomb sandwich panels. Although more costly, the honeycomb sandwich panels would have better acoustic damping and would not wrinkle like the tension field web with the application of load. Transverse loads developed by the tension field will be carried by stiffeners equally spaced along the webs normal to and tied into the longerons. Builtup, light-weight bulkheads are attached internally at the stiffener locations. The bulkheads provide support to maintain the cross-sectional shape of the box and to carry loads through the structure from hard points on the stiffeners for attachment of external internal stores. The bulkheads divide the box into four bays.

The central box is supported by a machined plate structure at each end of the box to which the STS Orbiter longeron trunnions are attached to take X and Z loads. The keel trunnion, which carries the Y loads, is attached to the structure on the underside of the box. Altogether, the 3S is supported in the Orbiter by a four point nonredundant trunnion arrangement (Figure 3-1) consisting of two opposed primary longeron trunnions and the keel trunnion in the same Y-Z plane and a stabilizing longeron trunnion on the -Y side. A light-weight handling trunnion is installed on the +Y side opposite the stabilizing trunnion to give symmetry for handling at the S/S.

Modifications necessary for converting the drop center box SFSS to the 3S primary support structure are relatively simple, and the two configurations could be easily changed from one to the other if necessary, because of the simplicity and modularity of the structure. The modifications and additions to the drop center box SFSS configuration necessary to convert to the 3S configuration are described in Appendix E and are visualized by referring to Figures 3-1 and 5-1.

5.1.1.2 Science Payload Interface Structure--The science payload interface structure supports the telescope or other science instruments and all instrument related electronics. The science payload interface structure is attached to the primary support structure and is composed of two major parts: the interface plate and the optical bench. The aluminum interface plate is approximately 60 by 96 inches with an opening to allow telescopes up to 48-inches diameter to be accommodated. The plate is reinforced by the prismatic box structure (Figure 5-2) to carry shear loads around the

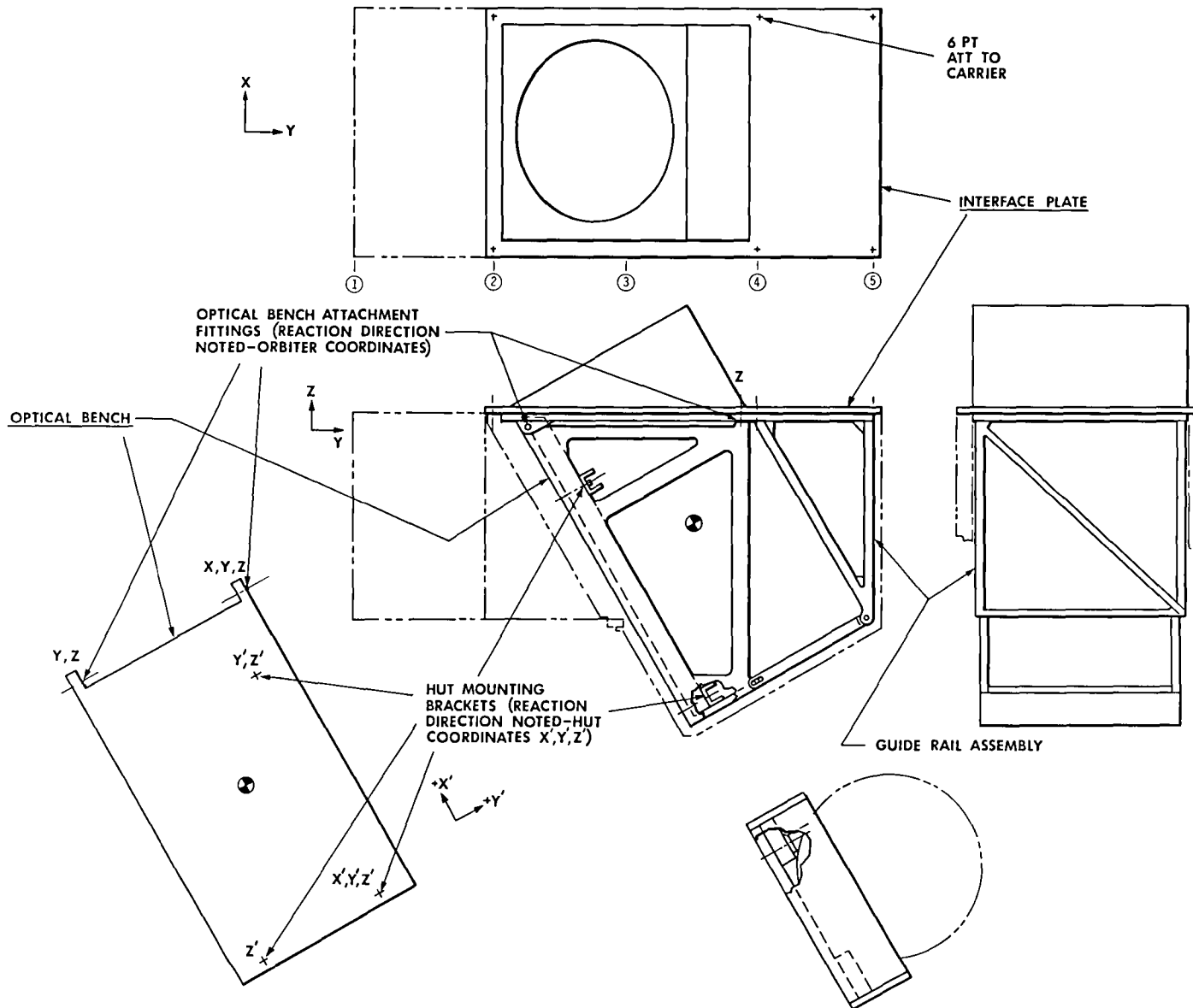

Figure 5-2. 3S Science Payload Interface Structure

opening and to provide rigidity to the plate. The plate also, by its geometry, allows a circular opening for the telescope. Clearance is provided for the telescope so as not to make contact. This plate is attached to the primary support structure by six fittings on the longerons at the stiffener junctions. This allows the minimum practical number of attachment points for ease of experiment changeout and yet carries the loads directly into the major load carrying elements of the primary support structure. The interface plate, with the possible exception of the opening reinforcement structure, will be the same for all experiment payloads and will support the electrical interface connector to the carrier. The optical bench directly supports the telescope and is attached to the interface plate at four points. The optical bench is a machined aluminum plate approximately 52 by 84 inches with triangular-shaped side plates for added stiffness and for attachment to the interface plate. Two of the four attachment points are at the corners of the bench plate and the side plates. Attachment is by two in-line pins parallel to the line formed by the intersection of the plane of the bench plate and that of the interface plate. This provides a hinge line with the fitting closest to the side to which the ACS module is attached taking X, Y, and Z loads, and the other fitting taking Y and Z loads. The second fitting is free in the X (pin axis) direction to allow for differential expansion. Rotation about the hinge (pin) line is prevented by two fittings at the apex of the two triangular end plates. These fittings take Z loads only and are free in X and Y providing a quasi-kinematic attachment of the optical bench. All fittings, although various degrees of freedom are allowed, fit very closely and are spaced widely apart to minimize alignment shifts. A shift of approximately 0.003 inch at the 64-inch distance between fittings will give a misalignment of approximately 10 arc-sec.

The strawman HUT instrument is attached kinematically to the optical bench as shown in Figures 2-1 and 5-2.

5.1.2 Subsystem Modules

Three box-like subsystem modules (ACS, power, C&DH) are attached to the side of the primary support structure as shown in Figure 2-1. This figure shows a preliminary estimate of the required sizes.

The ACS module is the approximate size of the module used on MMS. The power module is the same size as the ACS module which is more than adequate in volume; however, the 15 ft² radiator surface area is required for heat rejection. The C&DH module is smaller because the total length of the three modules must stay within the 128-inch length of the primary support structure. The resulting volume and radiator surface area are probably adequate; however, if necessary the box could be extended downward making attachment at the lower end slightly more complex. In Figures 2-1

and 2-2, attachment is to fittings mounted directly to the primary support structure top and bottom longerons for all the modules.

5.1.3 Solar Array

The solar array, as previously described in Section 2.1, is supported by a beam that also serves as a shaft for rotating the array (Figure 5-3). The beam is attached at its base to the primary support structure by a fitting that incorporates the rotation mechanism. This mechanism positions the array manually by EVA or by command through an electromechanical drive mechanism. The drive mechanism must be rigid in torsion and bending to minimize feedback to the ACS. The beam hinges just outboard to the drive mechanism and at two equally spaced (54.4 inches) points along its length. This position allows the array to be folded manually by EVA into a 128- by 54.4-inch package that is clamped against the side of the primary support structure to withstand launch and landing loads on the STS Orbiter. The array is composed of six identical 64- by 54.4-inch panels. Each folded section of the array is composed of two panels supported by the central beam and spars normal to the beam along the edges of the panels at the hinge line. Figure 5-3 shows the solar array and its deployment kinematics.

5.1.4 Propulsion Subsystem

The propulsion subsystem, as noted in Section 2.1, is a self-contained unit including up to three 28-inch diameter spherical propellant tanks. The tanks and other components are supported by a structure that also serves as a portion of the Y load carrying structure that supports the keel trunnion. See Figure 5-4. The propulsion subsystem is attached by six pins. Removal and installation can be performed by EVA without disturbing the keel trunnion. Electrical hookup is through a single connector which may be manually mated/demated.

5.2 SPACE STATION SPARTAN POWER SUBSYSTEM

5.2.1 Design Heritage

The 3S power subsystem design is based on the International Ultraviolet Explorer (IUE) and International Sun-Earth Explorer (ISEE) direct energy transfer (DET) system. The DET power subsystem design is advantageous for the 3S carrier because of its simplicity, use of existing hardware, and successful flight history. As with any power subsystem design, certain requirements were specified before the design effort. The 3S power subsystem design features and requirements are summarized in paragraph 5.2.1.1.

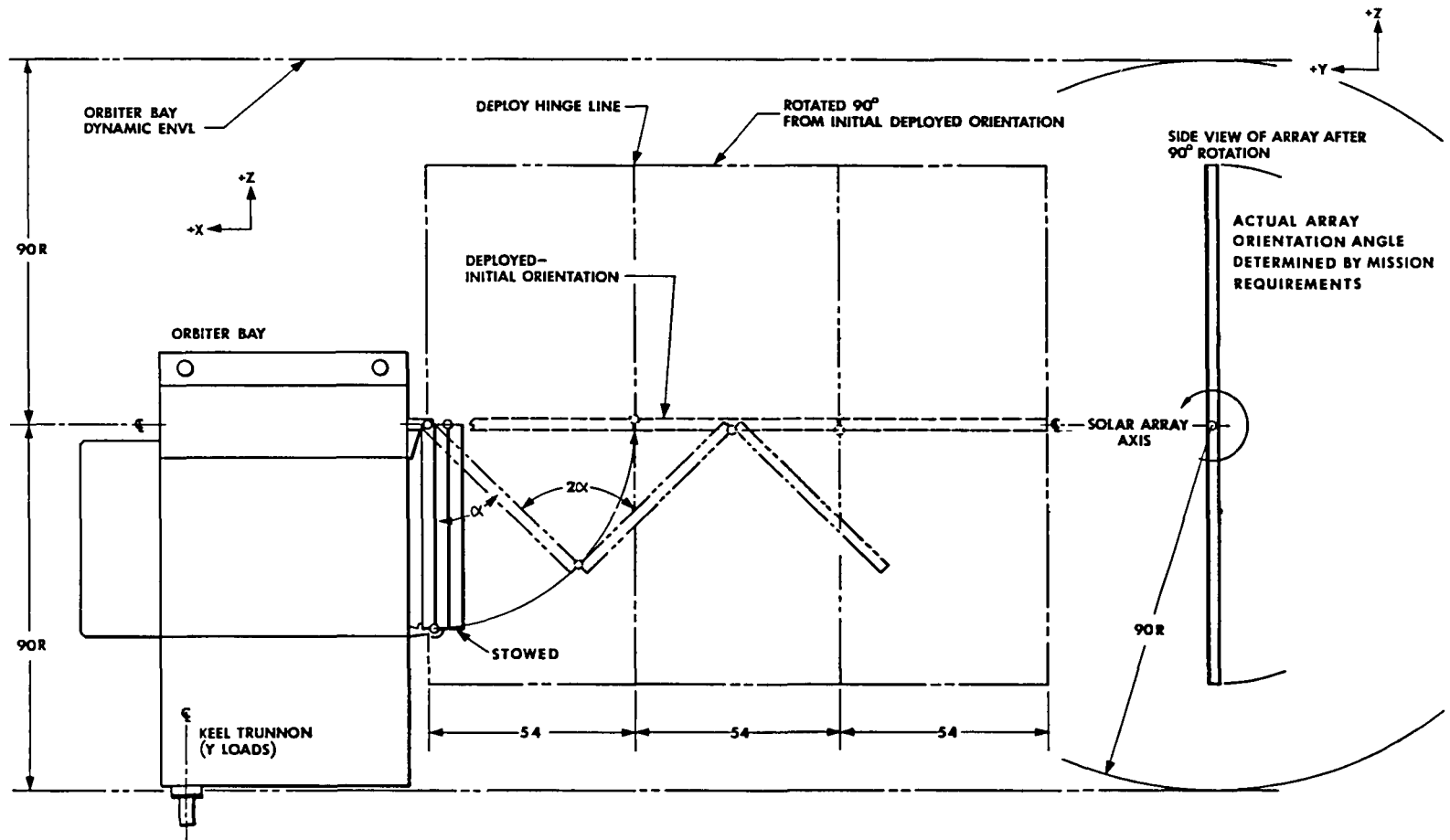

Figure 5-3. 3S Solar Array (dimensions in inches)

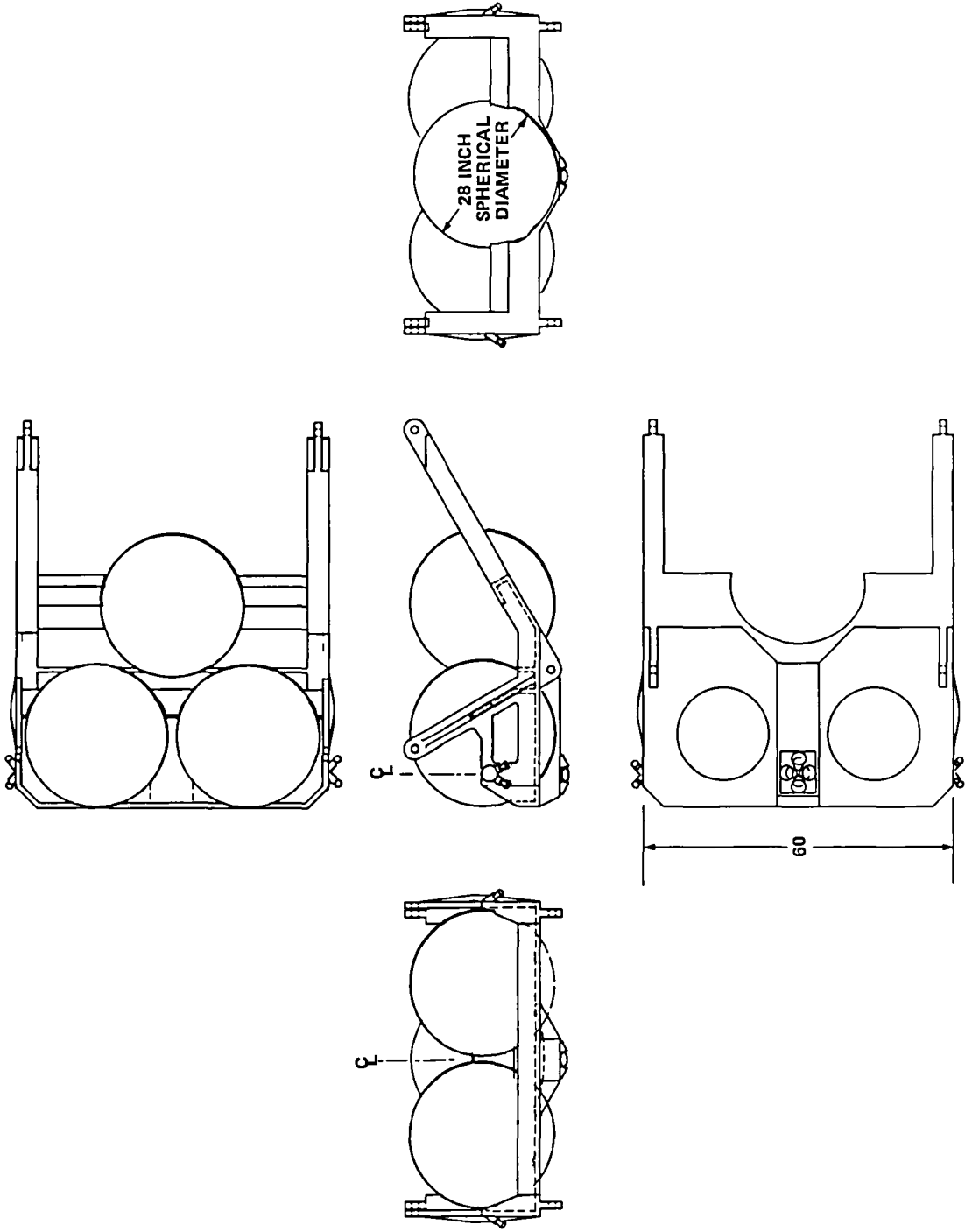

Figure 5-4. 3S Propulsion Subsystem (dimensions in inches)

5.2.1.1 Power Subsystem Design Description

a. Design Requirements

- 3-year lifetime in low-Earth orbit
- Minimal redundancy
- EVA deployable solar array
- EVA replaceable power subsystem module
- +28V regulated bus
- 642 watts orbital average load during stellar-pointing missions
- 594 watts orbital average load during solar-pointing missions

b. Design Type

- DET

c. Design Advantages

- Functional simplicity
- Use of existing hardware
- Successful flight history

d. Design Heritage

- IUE
- ISEE
- DET baselined for future GSFC flights

5.2.2 Functional Description

The main components of the 3S DET power subsystem, shown in Figure 5-5, are solar array panels, rechargeable nickel-cadmium (Ni-Cd) batteries, power supply electronics (PSE), and the 3S loads. The PSE and Ni-Cd batteries will be contained in a replaceable power subsystem module attached to the 3S carrier. The PSE will include boost regulator, battery charger, and shunt driver circuits having a peak load capacity of 800 watts. A control unit will monitor the status of the bus and activate the appropriate circuit so that the bus voltage will be maintained at 28 volts \pm 2 percent regulation during all phases of 3S missions.

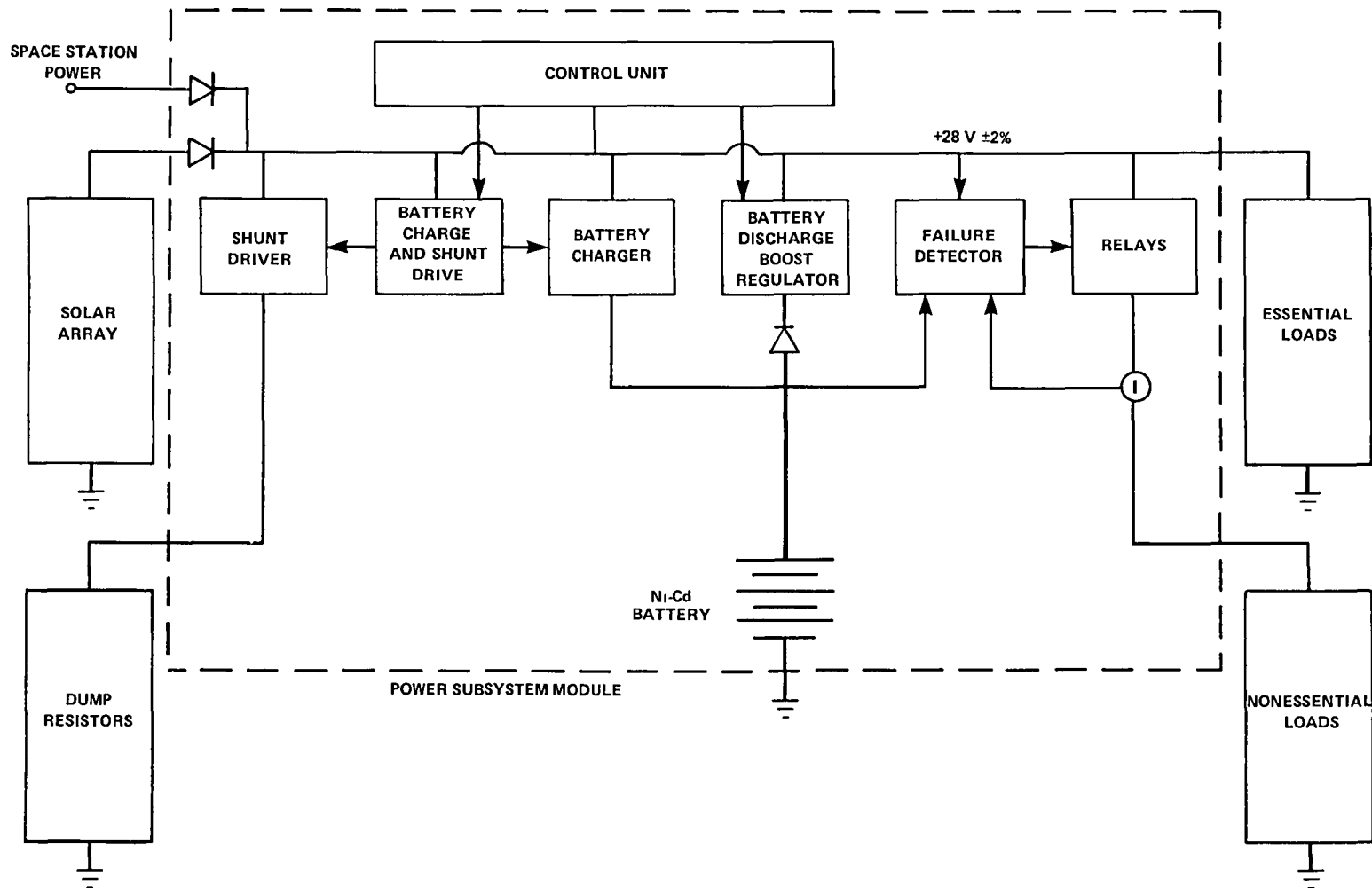

Figure 5-5. 3S Power Subsystem Diagram

During sunlight operations when the solar array output is approximately equal to the load demand, the PSE will operate within a dead band where neither the shunt driver, battery charger, or boost regulator is active. Thus, power will be supplied directly to the loads at high efficiency. If the solar array output exceeds the load demand, excess power will be provided to charge the battery, then additional excess power will be dissipated through the shunt dump resistors. During eclipse and certain sunlight operations when the load demand exceeds the solar array output, power will be supplied to the loads by discharging the battery through the boost regulator.

The PSE will also include a failure detector that monitors the bus voltage, the nonessential bus current, and the battery voltage. The failure detector will remove nonessential loads from the bus if an out-of-limit condition occurs.

5.2.3 Load Requirements

To develop load requirements for stellar-pointing missions (Table 5-1), the HUT is used as a strawman payload. During stellar observation, the HUT electronics bus and heater bus will require 163 watts and 147 watts orbital average power, respectively. For peak load operations, the electronics bus requirement will increase to 197 watts. During temporary deactivation, HUT will require a minimum of 3 watts for the electronics and 70 watts for the heater bus to ensure survival of the telescope.

The load requirements for solar-pointing missions (Table 5-2) is based on a strawman instrument cluster for solar corona studies (SCS). The SCS payload will require 212 watts and 50 watts orbital average power for electronics and thermal control, respectively.

As Tables 5-1 and 5-2 indicate, the 3S carrier subsystems that require electrical power are attitude control, thermal control, command and data handling, communications, propulsion, and power. All power subsystem dissipations except 25 watts of standby power are included as component inefficiencies in sizing the solar array and batteries. The orbital average load requirement for 3S carrier subsystems is 332 watts. The total orbital average load requirements for the carrier subsystems plus the instruments for stellar-pointing and solar-pointing missions are 642 watts and 594 watts, respectively.

5.2.4 Battery Size and Performance

In estimating the required battery size for 3S missions, it is assumed that the maximum eclipse duration will be 35.9 minutes.

Table 5-1
Load Requirements for 3S Stellar-Pointing Mission
(Instrument: HUT)

Subsystem	Orbital Average Load (Watts)	Peak Load
HUT electronics	163	197 W, 10 mins per target
HUT heaters	147	Aperture heat loss heaters
Attitude control	135	240 W, 8 mins per target
Thermal control	100	
Command and data handling	34	49 W, 1 hr per 24 hrs
Communications	13	34 W, 1 hr per 24 hrs
Propulsion	25	120 W, 2.5 mins per 2 wks
Power	<u>25</u>	TBD per array articulation
Total	642	

Table 5-2
Load Requirements for Solar-Pointing Mission
(Instrument: Solar Corona Studies (SCS) Cluster)

Subsystem	Orbital Average Load (Watts)	Peak Load
SCS electronics	212	
SCS thermal	50	
Attitude control	135	
Thermal control	100	
Command and data handling	34	49 W, 1 hr per 24 hrs
Communications	13	34 W, 1 hr per 24 hrs
Propulsion	25	120 W, 2.5 mins per 2 wks
Power	<u>25</u>	
Total	594	

Given the load requirements as derived in Table 5-1 and Table 5-2, the component inefficiencies of the PSE, and the previously mentioned eclipse duration, no more than 22 ampere-hours of available battery capacity will be used per eclipse. As shown in Table 5-3, the minimum battery size that can satisfy this requirement is three 20 ampere-hour Ni-Cd batteries. This battery complement should meet the 3 year design lifetime goal with a depth of discharge per orbit that is limited to 36 percent or less. Because the 3S will be serviced at least every 3 months, the power subsystem module should be replaced when the battery performance has degraded near or below flight qualification limits.

It is assumed that thermal control of the power subsystem module on the 3S carrier will maintain the battery temperature between 0° and 20°C during all phases of 3S missions. To achieve a 3-year lifetime, it is important that the batteries be discharged, shorted, and maintained between -10 and +5°C during storage on the ground, on board the STS, and on the S/S. Upon removing a shorting plug from the outputs of a power subsystem module in storage, the module may then be attached to a 3S carrier using S/S EVA. The batteries are required to be charged by S/S power supplied to a +29 Vdc input at the power subsystem module. If a S/S storage area temperature higher than +5°C is expected, it is required that life cycle (qualification) tests be performed on batteries that have been stored at the higher temperature.

Table 5-3
3S Battery Requirements

Requirements	Stellar-Pointing Mission	Solar-Pointing Mission
Load	642 W	594 W
Maximum eclipse duration	35.9 min	35.9 min
Discharge capacity per eclipse	21.57 amp-hrs	19.96 amp-hrs
Battery size	3x20 amp-hrs	3x20 amp-hrs
Depth of discharge	35.95%	33.27%

5.2.5 Solar Array Size and Performance

As Table 5-4 shows, the 3S solar array performance at end-of-life (3 years) will be 11.55W/ft². This estimate is based on a shallow-junction n/p silicon solar cell with a back surface field, a back surface reflector, and a 6-mil thick coverglass. The solar array outputs required to support orbital average loads for stellar-pointing and solar-pointing missions are 1366.8 watts and 1264.6 watts, respectively. An orbital period of 93.8 minutes (35.9 minutes eclipse and 57.9 minutes sunlight) has been assumed in determining the solar array output requirements. The energy balance calculations also include the power subsystem component inefficiencies. As Table 5-5 shows the required solar array areas for stellar-pointing and solar-pointing missions are 144.4 ft² and 109.5 ft², respectively. A solar array complement of six panels has been chosen for the 3S carrier. The size of each panel will be 64 inches by 54.4 inches, yielding a total area of 145 ft².

Table 5-4
3S End-of-Life Solar Array Performance

Solar cell peak power output at 28°C Before charged-particle irradiation	19.14 mW/cm ²
Solar cell irradiation dosage after 3 years (Cover: 6 mils, Orbit: 500 km, 28.5°)	7E+12 1 Mev e/cm ²
Solar cell peak power output at 28°C After charged-particle irradiation	18.64 mW/cm ²
Solar cell peak power output at 60°C After charged-particle irradiation	15.76 mW/cm ²
Solar array power loss factors	
Solar intensity variation--0.97	
Cell assembly mismatch--0.98	
Coverglass transmission--0.97	
Packing factor--0.90	
UV irradiation--0.98	
Thermal cycling--0.97	
End-of-life solar array output at 60°C	12.43 mW/cm ²
	11.55 W/ft ²

Table 5-5
3S Solar Array Requirements

Requirements	Stellar-Pointing Mission	Solar-Pointing Mission
Load	642 W	594 W
Maximum eclipse duration	35.9 min	35.9 min
Minimum sunlight duration	57.9 min	57.9 min
Solar array power	1366.8 W	1264.6 W
EOL solar array output	11.55 W/ft ²	11.55 W/ft ²
Projected area	118.3 ft ²	109.5 ft ²
Worst case Sun angle	35°	0°
Total area	144.4 ft ²	109.5 ft ²
Number of panels = six Size per panel = 64.0" x 54.4" Total area = 145 ft ²		

During solar pointing missions (Figure 5-6), all solar array panels will be facing the Sun. Thus, the solar array is capable of supporting orbital average loads up to 786.9 watts with energy balance each orbit. During stellar-pointing missions (Figure 5-7), the 3S carrier will be controlled so that the Sun remains in a single plane of the 3S. A Sun angle range of 180 degrees is possible. In the case of HUT as a 3S payload, the range will reduce to 140 degrees because the Sun is not allowed within 40 degrees field of view of the telescope. Two solar array positions will be required during stellar-pointing missions: one position for Sun angles from 0 to 70 degrees and the other position for Sun angles from 70 to 140 degrees. A simple stepper motor, two position drive will be used to articulate the solar array from one position to the other as required during the mission. Sliprings will not be required. Table 5-6 gives the solar array output and load capability over the range of Sun angles for both array positions. The solar array is capable of supporting orbital average loads up to 786.9 watts and 644.6 watts at the best and worst case Sun angles, respectively.

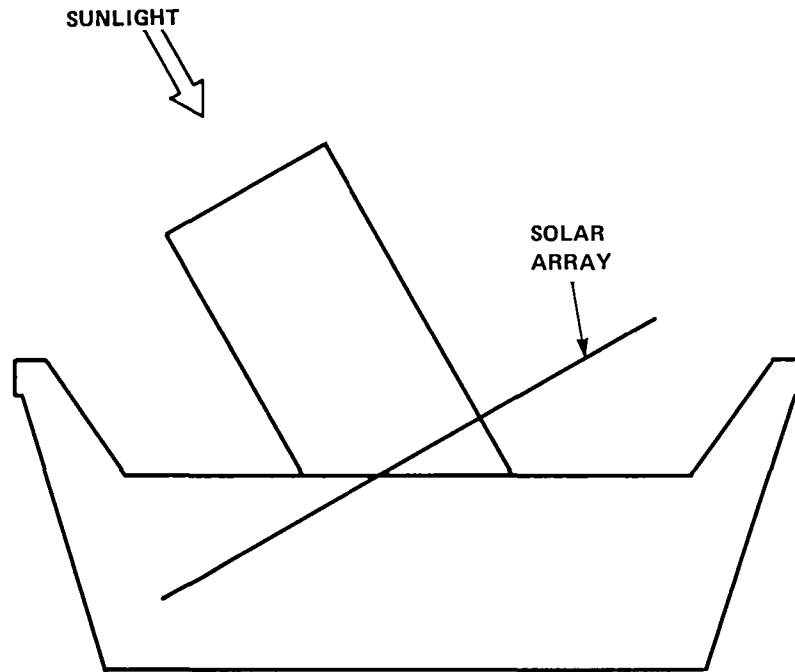

Figure 5-6. Solar Array Configuration During Solar-Pointing Mission (Solar Array and Instrument Pointed to the Sun)

5.2.6 Physical Description

The following weights are for each of the 3S power subsystem components:

- Power supply electronics (one box)--29 pounds
- Batteries (3 x 20 ampere-hours)--152 pounds
- Solar array (145 ft²) (including cells, wiring, and honey-comb)--128 pounds
- Dump resistors (one box)--7 pounds

Total weight of the above power subsystem components--
316 pounds

Note that module structures, drive mechanisms, and thermal components are not included in this total. The dimensions of each 3S power subsystem component are given in Table 5-7. The specific design of the module is to be determined with primary consideration given to EVA servicing and thermal control.

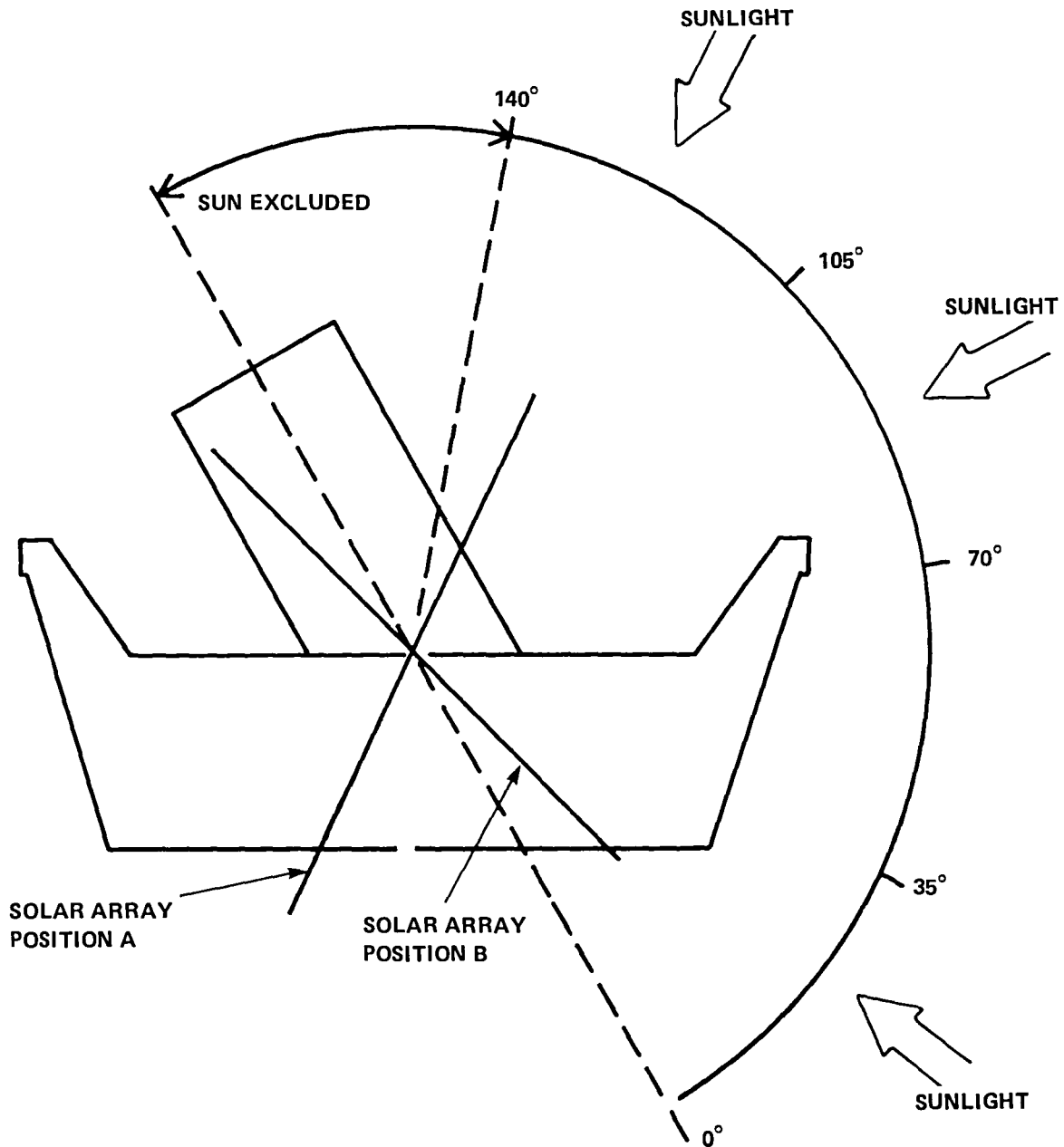

- SUN RESTRICTED TO A SINGLE PLANE OF THE 3S CARRIER
- SUN ANGLE RESTRICTED TO A RANGE OF 140°
- SOLAR ARRAY POSITION A FOR SUN ANGLES FROM 0 TO 70°
- SOLAR ARRAY POSITION B FOR SUN ANGLES FROM 70 TO 140°

Figure 5-7. Solar Array Configuration During Stellar-Pointing Mission

Table 5-6
Power Profile During Stellar-Pointing Mission

Sun Angle (Degrees)	Array Position A		Array Position B	
	Solar Array Output (Watts)	Orbital Average Load Capability (Watts)	Solar Array Output (Watts)	Orbital Average Load Capability (Watts)
0	1371.8	644.6	0	0
5	1450.3	681.5	0	0
10	1517.8	713.2	0	0
15	1573.7	739.5	0	0
20	1617.6	760.1	145.9	68.5
25	1649.3	775.0	290.8	136.6
30	1668.3	783.9	433.4	203.6
35	1674.7	786.9	572.7	269.1
40	1668.3	783.9	707.7	332.5
45	1649.3	775.0	837.3	393.4
50	1617.6	760.1	960.5	451.4
55	1573.7	739.5	1076.5	505.8
60	1517.8	713.2	1184.2	556.4
65	1450.3	681.5	1282.9	602.8
70	1371.8	644.6	1371.8	644.6
75	1282.9	602.8	1450.3	681.5
80	1184.2	556.4	1517.8	713.2
85	1076.5	505.8	1573.7	739.5
90	960.5	451.4	1617.6	760.1
95	837.3	393.4	1649.3	775.0
100	707.7	332.5	1668.3	783.9
105	572.7	269.1	1674.7	786.9
110	433.4	203.6	1668.3	783.9
115	290.8	136.6	1649.3	775.0
120	149.9	68.5	1617.6	760.1
125	0	0	1573.7	739.5
130	0	0	1517.8	713.2
135	0	0	1450.3	681.5
140	0	0	1371.8	644.6

Table 5-7
Component Dimensions

Component	Quantity	Dimensions per Unit (inches)
PSE box	1	24 by 12 by 9
Batteries	3	14 by 8 by 10
Solar array panels	6	64.0 by 54.4 by 1
Dump resistor box	1	TBD

5.3 SPACE STATION SPARTAN THERMAL CONTROL SUBSYSTEM

The 3S will use standard thermal control techniques that include heaters, thermostats, louvers, multilayer insulation (MLI), and thermal coatings. This passive/active technique has been used on many spacecraft and is considered sufficient and reliable.

The entire 3s will be covered with MLI that has an outer layer of diffuse silver teflon. This layer will reject much of the environmental energy and will be optically trackable.

The 3S is designed using a modular concept. The thermal design concept for the power, C&DH, and ACS modules is to insulate (MLI) all sides except the side facing space. Louvers, mounted on the space side, will keep the module within a narrow temperature range regardless of changes in external environment or internal power. Heaters and thermostats, mounted on the radiator surface, will prevent the temperature of the module from decreasing below 0°C during times when the modules are powered down. Louver areas are sized for the modules depending on their internal power, and heaters are sized to maintain the modules at 0°C in the nonoperational mode.

The propulsion module consists of three spherical hydrazine tanks, nozzles, and assorted hardware. Because hydrazine freezes at +2°C it is important to maintain all components well above this temperature. The thermal design concept is to use heaters and thermostats that maintain the temperature of all components at about 10°C to allow margin in the design. MLI will be used to minimize energy requirements.

The instrument module thermal design and preparation of an instrument thermal model is considered the responsibility of the PI group. Interface restrictions such as minimizing heat transfer between the 3S and the instrument will be placed on the design.

A complete 3S system analysis will be accomplished to ensure that interface requirements are understood and met. The instrument has been allocated 100 watts for thermal control during the operational mode. If the instrument electronics are separate from the instrument, the 3S will assume responsibility for thermal control. The 3S will have louver controlled radiator plates to which the electronics shall be mounted.

During the Shuttle phase, a separate set of survival heaters and thermostats are mounted on the S/S and exposed to the environment to maintain the spacecraft and components at survival temperatures. An environmentally controlled tent is mandatory when the 3S instruments or modules are stored on the S/S. Analysis indicates that surface temperatures will exceed -100°C to $+100^{\circ}\text{C}$, and component temperatures will exceed survival limits without a controlled environment.

If the 3S is to be transferred to its orbital position by the OMV, the 3S modules must be in a powered-down mode because the OMV blocks the modules from radiating to space.

Preliminary estimates have been made of operational power, required thermal louver area, and required heater power for the 3S subsystems and the HUT instrument. See Table 5-8 for the results of these estimates.

5.4 SPACE STATION SPARTAN COMMAND AND DATA HANDLING SUBSYSTEM

5.4.1 Introduction

The 3S C&DH equipment is single string (nonredundant) and designed to allow easy integration of instrument payloads and replacement modules on the S/S. The CDHS has the following features:

1. The instruments are provided with a RS422, 1200 baud serial interface for configuration purposes.
2. Downlinked pulse-code modulation (PCM) telemetry data are packetized to allow asynchronous data collection.
3. The 3S subsystem interfaces to the C&DH equipment are serial digital thus minimizing the number of discrete wires for the various units.

5.4.2 Functions

The 3S C&DH equipment transmits data in real time while capable of simultaneously storing these data in an optional tape recorder.

Table 5-8
Space Station Spartan Thermal System
Louver and Heater Requirements

System	Operational Power (Watts)	Louver Area Required (Square Feet)	Thermal Heater Required (Watts)
Power module	200	13.0	100
C&DH module	100	6.5	50
ACS module	100	6.5	50
Propulsion module	~0	--	50
Science instrument electronics	100	6.5	50
Science instrument	--	--	100

Continuous transmission of up to 500 kbps, real-time data is anticipated. The following functions are performed by the 3S C&DH equipment following:

- Using a variation of the HITCHHIKER avionics interface adapter, the C&DH subsystem decodes the serial-digital (S/D) commands at either 125, 1000, or 2000 bps, as pertinent, from
 - (1) The 3S command receiver
 - (2) The Orbiter in-bay hardline
 - (3) The S/S hardline
- Error checks uplink command words.
- Reformats received serial commands to serial 1200 baud RS422 10-bit words for each of the five instruments.
- Provides 1024 bytes of command word storage to enable autonomous 3S operation for 24-hour periods.
- Distributes serial-digital command to 3S subsystems (power, ACS, propulsion, thermal, RF communications, and C&DH).
- Collects serial-digital science data from up to five instruments.
- Collects serial 1200 baud, RS422 housekeeping telemetry, and configuration data from up to five instruments sequentially.
- Collects serial-digital status data from all 3S subsystems.

- Synchronously and sequentially samples instrument RS422 telemetry and configuration data and 3S subsystem status data with an existing Spartan PCM telemetry encoder manufactured by Vector and routes these data to the Packet telemetry medium rate multiplexer (MUX) developed for the HITCHHIKER-G.
- Provides hardline telemetry interfaces for Orbiter Payload Data Interleaver (PDI) and the Ku-band signal processor (KUSP). (It is assumed that these interfaces will be identical to the S/S hardline telemetry interfaces and will be used accordingly.)
- Provides up to 10^9 bits of tape recorder data storage as an option.
- Provides a real-time telemetry and a tape recorder playback interface with the 3S transmitter for a total data rate up to 500 kbps.
- Provides an optional tape recorder playback interface through the HITCHHIKER medium rate MUX.
- Provides an adjustable rate packet telemetry downlink with a 72 byte transport frame. The maximum rate capability of the HITCHHIKER MUX is 1.4 mbps, and the nominal maximum 3S downlink rate is 500 kbps. This downlink rate is limited by the S-band communications link and the slant range between the 3S and the S/S.
- Provides convolutional encoding of downlink telemetry data to improve bit error rate performance.
- Generates and distributes clock signals to the instruments and the HITCHHIKER medium rate MUX.

Table 5-9 lists the approximate size, weight, and power of the 3S C&DH equipment.

Figure 5-8 is a block diagram of the 3S C&DH subsystem.

5.5 SPACE STATION SPARTAN COMMUNICATIONS (RF) SUBSYSTEM

The 3S communications system provides a two-way RF link for transmitting telemetry and scientific data and for receiving command and memory load capability to and from the S/S as required. In addition, tracking data will be required for 3S stationkeeping. The communications system provides the following:

- A science/telemetry S-band RF data link at 500 kbps, operating continuously to the S/S

Table 5-9
C&DH Characteristics

Box	Size (inches)	Weight (pounds)	Power (28 V) (watts)
Avionics interface adaptor	8 x 8 x 8	7	5
Vector PCM encoder	1.5 x 2 x 3	1	12
Medium rate MUX	8 x 8 x 4	3.5	5
XMTR-S/S-STC interface box	8 x 8 x 6	5	5
Tape recorder (optional)	10 x 11 x 7	23	14 Record 21 Playback

- A command and memory load data link operating at S-band from the S/S at data rates of 125 bps and 1 and 2 kbps compatible with TDRSS and GSTDN
- Tracking and range data for use with 3S stationkeeping and orbit adjustment

The strawman communications system, which uses the S/S as a "bent pipe" data relay to TDRSS and the ground, provides an economical means for continuous communication between the 3S and the 3SOCC. The S/S must provide a fixed-beam antenna (20° by 20°) with a 17-db boresight gain "looking out" the antivelocisty direction.

This system, together with a 5 watt RF standard S-band transponder and a 3S omnidirectional antenna system, provides appropriate communications up to 250 n.mi. from the S/S. A larger, 4-foot diameter, steerable antenna on the S/S could provide communications up to 1000 n.mi., and an omni antenna on the S/S would limit the link to 100 n.mi. at 200 kbps or 1 kbps at 1000 n.mi. A summary of the link calculations is shown in Table 5-10.

In addition, telemetry and command links with suitable GSTDN can easily be maintained. The communication system consists of a transponder, two hemispherical coverage antennas with diplexers, a switch and a coupler. The antennas are hybrid coupled for omni directional receive capability and switched for hemispherical transmit.

Figure 5-9 shows the system diagram. Usually, the command link has an appropriate positive margin and in an emergency can receive

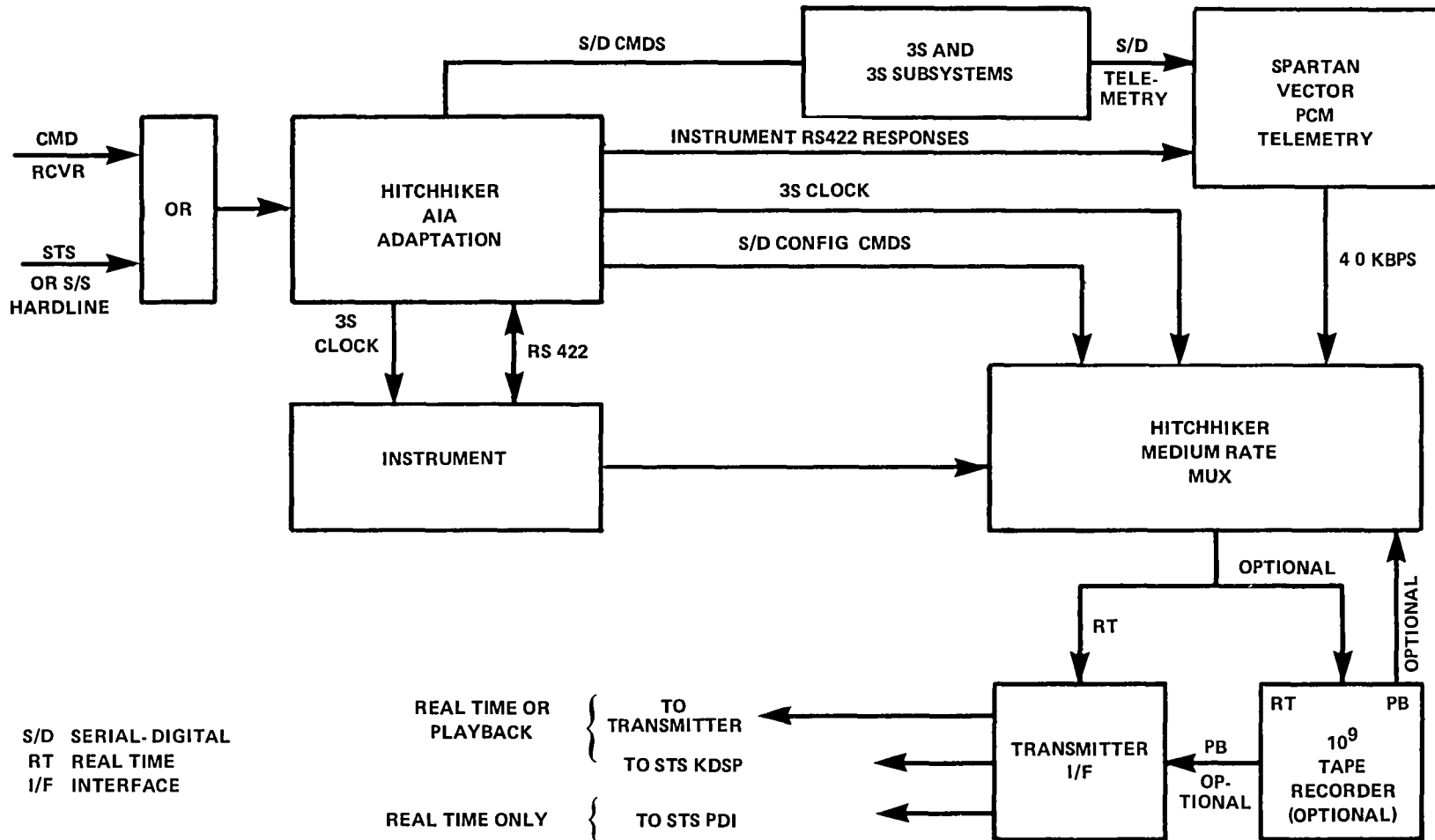

Figure 5-8. 3S C&DH Block Diagram

Table 5-10
3S Communication Subsystem Link Calculation

	S/S Omni		S/S 4 ft Reflector	S/S 20° x 20° Fixed Beam
Pt, 5 W	37 dbM	--	37 dbM	37 dbM
S/S Antenna, omni	-2 db	--	24 db	14 db
3S Antenna, omni	-2 db	--	-2 db	-2 db
Path loss (1 km.)	-165 db	--	-165 db	--
Path loss (250 mi)	--	--	--	-153 db
Path loss (100 mi)	--	-145 db	--	--
MOD loss	-2 db	-2 db	-2 db	-2 db
POL loss	-1 db	-1 db	-1 db	-1 db
Signal received	-135 dbM	-115 dbM	-109 dbM	-107 dbM
Noise density	-174 dbM/Hz	-174 dbM/Hz	-174 dbM/Hz	-174 dbM/Hz
S/N/Hz	39 db/Hz	59 db/Hz	65 db/Hz	67 db/Hz
S/N required	6 db	6 db	6 db	6 db
S/N available	33 db	55 db	59 db	61 db
Data rate available	30 (1 kbps)	53 (200 kbps)	57 (500 kbps)	57 (500 kbps)
Margin	3 db	2 db	2 db	4 db
Command margin 2 kbps	0 db	22 db	26 db	28 db

Note the following considerations:

- (1) Frequencies--22XX and 20XX MHz, S-band
- (2) Antennas--Several types
- (3) Distance--Up to 1,000 n.mi. from S/S, data rate dependent
- (4) Data Rate--Up to 500 kbps
- (5) Transmit capability--5 watts
- (6) Convolution coding is used.
- (7) The return data link is the most difficult to complete.
The command link and range data link will be satisfactory
when the data link has a positive margin.

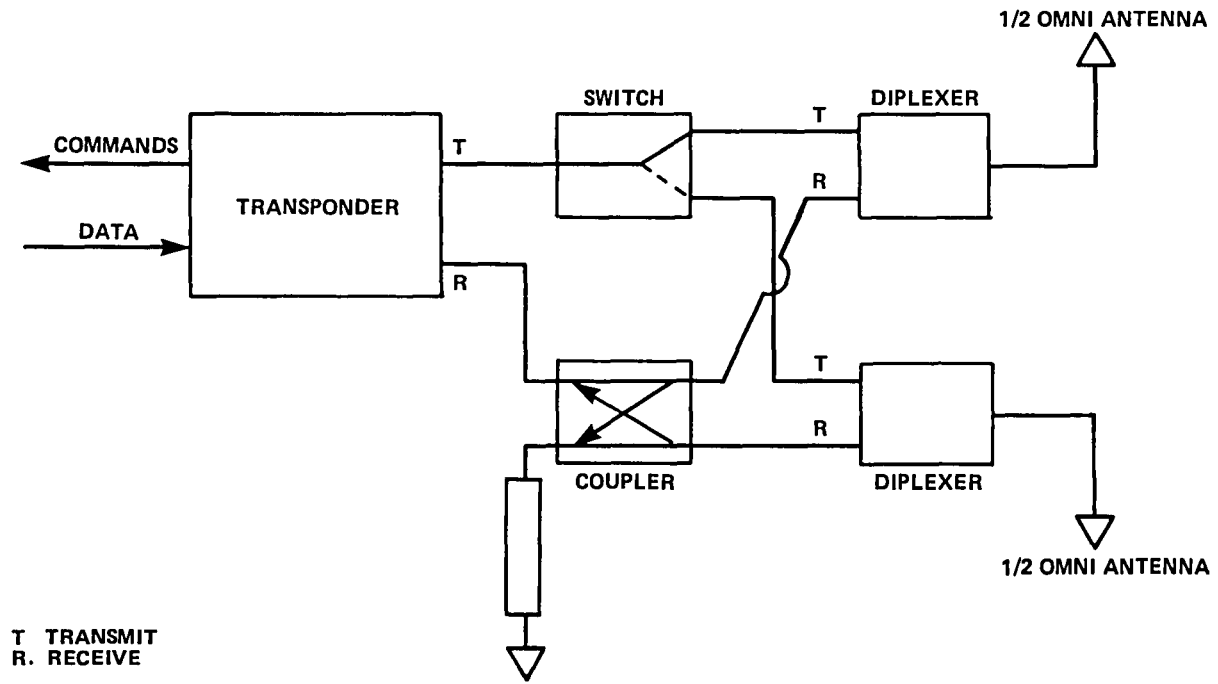

Figure 5-9. System Diagram of 3S Communications System

125 bps from TDRSS. The following summary indicates the power, weight, and volume of the 3S communications system:

a. Power

- Receive--9 watts
- Transmit and receive (5 watts) peak--34 watts

b. Weight--12 pounds

c. Volume--300 in²

Figure 5-10 is a schematic of the anticipated RF link.

5.6 SPACE STATION SPARTAN ATTITUDE CONTROL SUBSYSTEM

5.6.1 Introduction

The 3S ACS is required to orient the 3S to any celestial target outside a 40 degree half angle cone about the Sun line during astrophysical (e.g., HUT) missions, and to orient the spacecraft to anywhere near the solar disk during solar (e.g., solar cluster) missions. In addition, the ACS is required to orient the 3S for thruster firings during stationkeeping maneuvers. The ACS will be capable of managing the orientation of the solar array to maximize the solar power collection during the mission. For safety, the ACS will have a simple safe-hold mode to safeguard the power supply and thermal integrity of the 3S and to maintain a sufficiently stable attitude for safe retrieval by the OMV. The initial (basic) ACS must be sufficiently capable of accommodating the requirements for the first generation of 3S users. Evolutionary growth in ACS capability can be implemented whenever future generations of 3S user requirements become more demanding.

5.6.2 Performance Requirements and Assumptions

The following performance parameters were derived from the strawman science instrument payloads:

- 30 arc-sec absolute pointing (except during slew)
- 1 arc-sec short term (jitter) stability over 10 seconds
- Attitude drift ≤ 0.003 degree per hour without error correction from instrument
- ACS capable of accepting error signal from science instrument
- Astrophysical, solar, and X-ray observation missions only (i.e., no Earth-pointing missions)

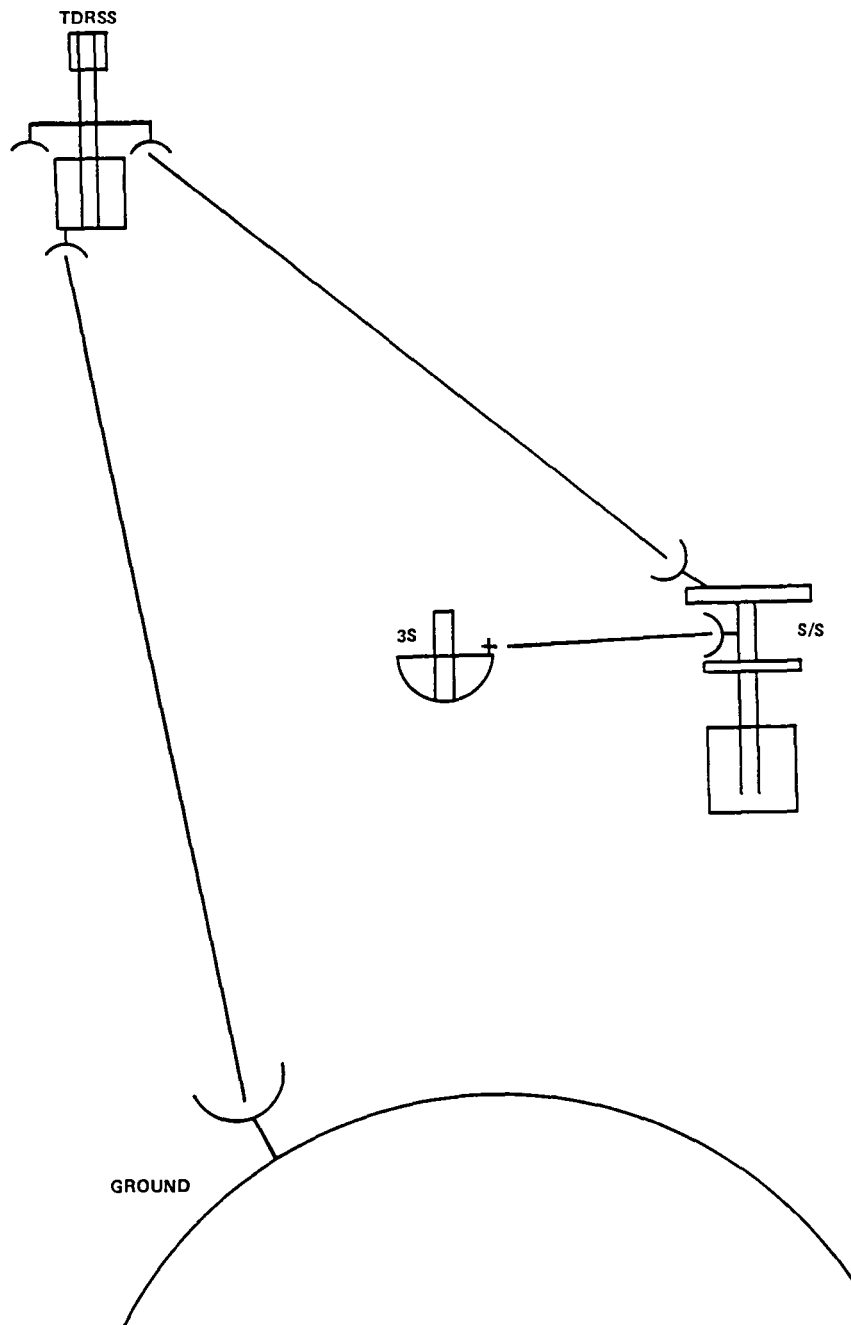

Figure 5-10. RF Communications Link to 3S

The absolute accuracy requirement is applicable within a reasonable time after a star update to the gyros.

5.6.3 Design Approach and Rationale

The performance requirements of the 3S ACS for the strawman payloads appear as demanding as the requirements of the SMM. The SMM uses the modular ACS (MACS) of the MMS. Therefore, it is reasonable to assume that component subsystems of the 3S ACS must have similar performance and must have characteristics similar to those of the MACS. The apparent high cost of an MMS-type ACS may be unacceptable in a program intended as an extension of the STS/Spartan concept. For 3S users with relaxed pointing performance requirements, however, other ACS configurations may be considered. One of these configurations is the simple ACS used in the current STS/Spartan, but equipped with hydrazine rather than cold gas for torquing to provide extended operating time.

In addition, an intermediate system has been examined that uses reaction wheels similar to that of the SMM, but retains the lower performance star trackers and gyros used on the current Spartan ACS. Whichever class of component subsystems are chosen for the 3S/ACS, all approaches require a dedicated onboard microcomputer to implement the control laws and to have the capability to accommodate the diverse mission scenarios. In this document, these three different implementations shall be called configurations 1, 2, and 3.

Configuration 1--Enhanced Shuttle Spartan ACS with hydrazine for torquing

Configuration 2--Enhanced Shuttle Spartan ACS with reaction wheels for torquing

Configuration 3--MMS type ACS

5.6.4 Disturbance Environment and Component Sizing

At the S/S orbit of approximately 500 km, the dominant disturbance torques acting on the 3S are the gravity gradient and the aerodynamic torques. In addition, for payloads such as the HUT, which have a massive invar structure, the magnetic disturbance torque is very significant and may require special treatment.

For a system such as configuration 1, which uses thrusters for attitude stabilization, the external disturbance environment is not important because the bang-bang limit cycle of the ACS dominates the propulsion fuel requirement. For configurations 2 and 3, however, the sizing of the reaction wheels depends a great deal on the external disturbance environment. As a minimum, the reaction wheels should have sufficient momentum capacity to store the

periodic component of momentum caused by the environmental disturbance torques. If magnetic torquing is used to manage the secular momentum accumulation of the 3S as in the MMS, then the orbital average of the available torque from the onboard magnetic torquers must be greater than the secular component of the environmental disturbance torques to prevent runaway momentum accumulation.

The gravity gradient and aerodynamic torques are highly sensitive to mass distribution, form factor, and orientation of the 3S. Based on some preliminary worst case analysis, the 20 newton-meter-seconds capacity of the NASA standard reaction wheels used on SMM will not be adequate for some inertial orientations of the 3S. To size an ACS to cope with all possible situations, however, would be prohibitively expensive. A far more reasonable approach, consistent with the 3S concept, is to size the system to cope adequately with approximately 90 percent of all possible pointing orientations. In this way, mission objectives can be met by using the propulsion module to back up the reaction wheels and the magnetic torquing system during the presumably short duration when the capacity of the reaction wheels is inadequate. For this reason, only reaction wheels that are not larger than 20 newton-meter-seconds will be considered.

5.6.5 Preliminary Design

Figures 5-11 and 5-12 show top level functional block diagrams of the 3S ACS configurations. The features of each configuration are described in paragraphs 5.6.5.1, 5.6.5.2, and 5.6.5.3. A summary of comparative performances of these configurations is presented in paragraph 5.6.5.4.

5.6.5.1 Configuration 1--This configuration is an enhanced version of the current STS/Spartan ACS. The minimum modification is the resizing of the propulsion system to meet the 1 to 3 months 3S mission duration compared to the 40 hours of the current Spartan. The design of the propulsion system is described separately in another part of this report. Another modification to the Spartan ACS is the implementation of all control laws and operational management of the ACS in a microprocessor. This change is necessary because the 3S will not be returned to the ground for servicing and consequent reprogramming between instrument changeouts. Therefore, the mission configuration for the ACS must be accomplished through software. A magnetometer and magnetic torquer system are included to increase the probability of 3S retrieval if the ACS becomes inoperative.

Major component subsystems include:

- Gyros assembly--Two required, Spartan TRIG gyro (two axes/gyro), 0.03 degree/hour drift stability

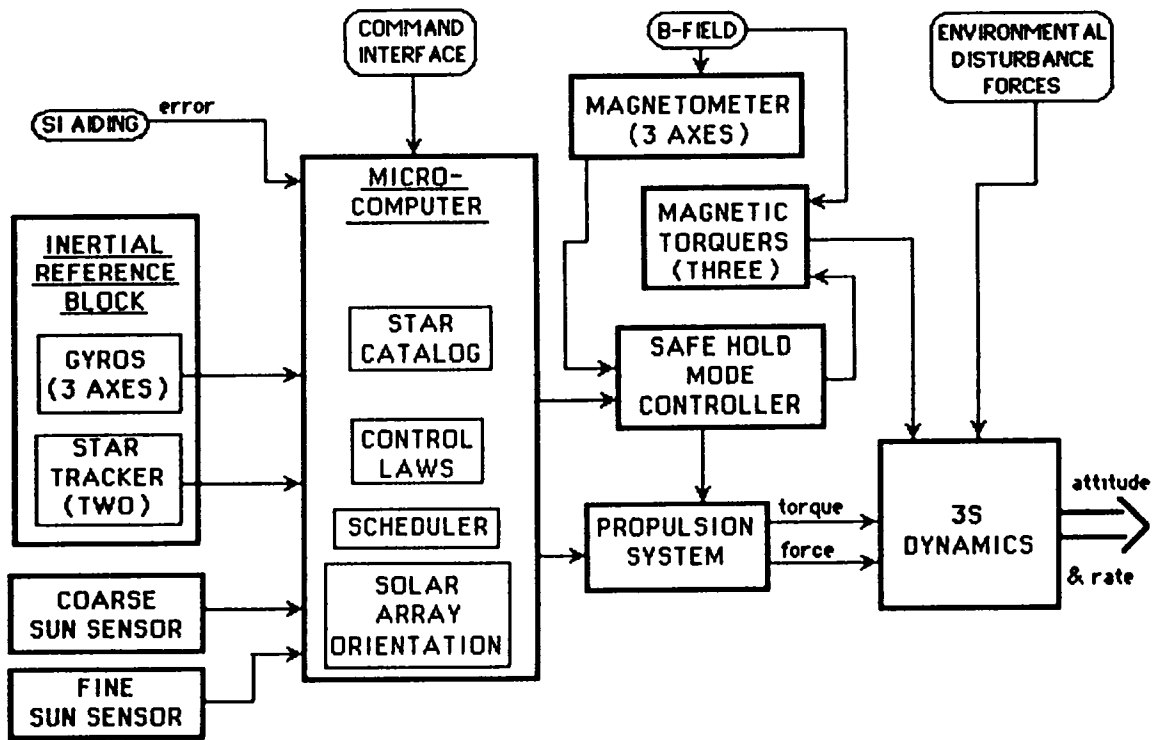

Figure 5-11. Block Diagram of ACS Configuration 1

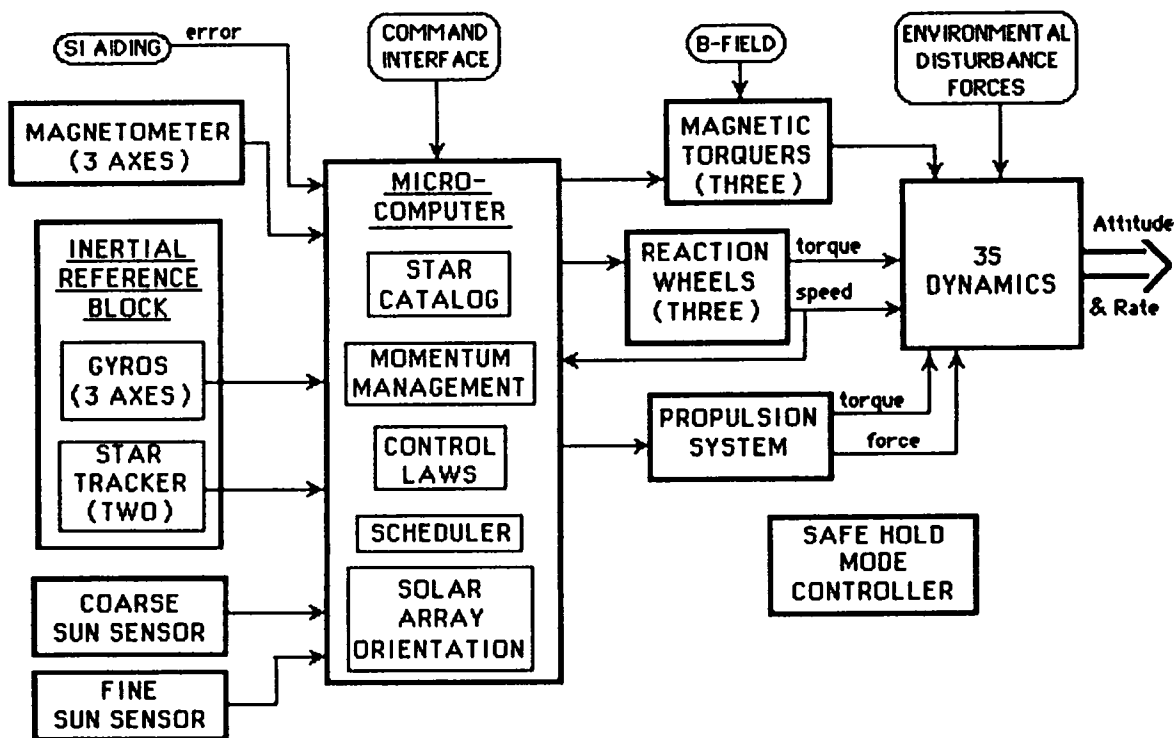

Figure 5-12. Block Diagram of ACS Configurations 2 and 3

- Star trackers--Two required, NASA fixed head analog star tracker 8 by 8 degree FOV, +4 magnitude star sensitivity, TBD arc-sec accuracy (1 sigma)
- Reaction wheels--Not required
- Sun sensors--As required
- Magnetometer--One required, 3-axis magnetometer, MMS heritage
- Magnetic torquers--Six required, 50,000 pole-cm electro-magnet, MMS heritage
- Dedicated microprocessor--One required, hardware to be defined
- Propulsion system--Required to provide control torque instead of reaction wheels, estimate is about 690 pounds of nitrogen gas or 189 pounds of hydrazine per month of operation just for attitude stabilization and control.

5.6.5.2 Configuration 2--This configuration is similar to configuration 1 with the exception that reaction wheels rather than thrusters will be used for attitude stabilization, and will provide substantial improvement in short term pointing stability. The absolute pointing accuracy and the long term drift stability will not be better than in configuration 1.

Major component subsystems include:

- Gyros assembly--Two required, Spartan TRIG gyro (two axes/gyro), 0.03 degree/hour drift stability
- Star trackers--Two required, Spartan fixed head analog star tracker, 8 by 8 degree FOV, +4 magnitude star sensitivity, TBD arc-sec accuracy (1 sigma)
- Reaction wheels--Three required, NASA standard reaction wheel or equivalent 20 n-m-s capacity, 0.15 n-m torque
- Sun sensors--As required
- Magnetometer--One required, 3-axis magnetometer, MMS heritage
- Magnetic torquer--Six required, 50,000 pole-cm electro-magnet, MMS heritage
- Dedicated microprocessor--One required, hardware to be defined

- Propulsion system--Required to augment the magnetic torquing system

5.6.5.3 Configuration 3--This configuration uses major component subsystems with the MMS heritage and meets the performance requirements of the strawman science instruments. The complement of major component subsystems include:

- Gyros assembly--One required, NASA Standard DRIRU-II with three gyros (two axes/gyro) including electronics, 0.003 degree/hr drift stability
- Star trackers--Two required, NASA standard fixed head star tracker 8 by 8 degree FOV, +5.7 magnitude star sensitivity, 10 arc-sec accuracy (1 sigma), 5 arc-sec noise equivalent angle
- Reaction wheels--Three required, NASA standard reaction wheel or equivalent 20 n-m-s capacity, 0.15 n-m torque
- Sun sensors--As required
- Magnetometer--One required, 3-axis magnetometer, MMS heritage
- Magnetic torquer--Six required, 50,000 pole-cm electromagnet, MMS heritage
- Dedicated microprocessor--One required, hardware to be defined
- Propulsion system--Required to augment the magnetic torquing system

5.6.5.4 Performance Estimates--Based on sensor and component subsystem performance parameters, Table 5-11 shows a rough estimate of the expected performance of the three ACS configurations.

Table 5-11
Expected Performance of ACS Configurations

Performance Characteristic	Configurations		
	1	2	3
Accuracy (arc-sec)	120	120	30
Jitter (arc-sec p-p)	10.0	1.0	1.0
Drift (deg/hour)	0.03	0.03	0.003

5.6.5.5 Operational Scenario--Upon separation from the OMV that ferries the 3S to its initial orbit station, the ACS is activated automatically by a separation signal and enters into a "safe-hold" mode. While in this mode, the ACS searches for the Sun and orients the 3S to point the solar arrays toward the Sun. Then the 3S will rotate slowly about the solar vector to search for at least two pre-programmed guide stars to calibrate to gyros in the inertial reference unit. At this point the ACS is ready for routine operation.

5.6.5.5.1 Solar Mission--For solar observation missions, the 3S science instrument boresight axis remains oriented toward the Sun. Offset pointing capability up to a few degrees will be provided. Error sensing can be derived from the fine Sun sensor, the gyros, or the science instrument produced pointing error signals. The roll angle about the science instrument boresight axis will be controlled by gyro signals, but updated by one of the two fixed head star trackers when convenient preselected guide stars are within the field of view of the star trackers.

5.6.5.5.2 Astrophysical Mission--For missions that require the science instrument boresight axis to point at targets other than the Sun, the ACS is required to slew the science instrument boresight axis to anywhere in the celestial sphere except a 40 degree half-angle cone of exclusion about the Sun line. The 3S attitude is maintained by integrating the inertial angular rate of the 3S as sensed by the gyros. To maintain the necessary accuracy, the gyros require star tracker measurement updates at least once per orbit and preferably more frequently. The roll orientation of the 3S will be such that the Sun line will always be contained in the plane determined by the science instrument boresight axis and the solar array normal. This arrangement maintains a reasonable attitude for solar power collection efficiency and ease of thermal control. Slewing can be performed by either the reaction wheels or the propulsion system depending on the ACS configuration.

5.6.5.5.3 Delta-V Maneuver--Whenever the 3S requires a Delta-V maneuver for stationkeeping purposes, the ACS is required to slew the 3S so that the propulsion subsystem nozzles are aimed to the direction that the Delta-V requires. This maneuver would ideally be performed during a portion of the 3S orbit when the science target is not visible to the science instrument. After the maneuver, the 3S is slewed back to its previous pointing direction or to a new target.

5.6.6 On-Orbit Stationkeeping and Evolutionary Considerations

On-orbit stationkeeping is necessary because of large differences between S/S and 3S decay caused by aerodynamic drag. The baseline design of the 3S CDHS requires a bounded line-of-sight distance from the S/S to support the RF link. Stationkeeping is considered under ACS design because of the interdependency between the two systems. Whenever a Delta-V maneuver is required, the ACS must

interrupt its pointing function and align the thrust vector to the desired orientation. ACS pointing may be resumed when the stationkeeping operation is completed.

The stationkeeping maneuver can be accomplished through ground control or autonomously by the ACS. An additional requirement to implement autonomous stationkeeping is the near real-time range measurement to the S/S.

5.7 SPACE STATION SPARTAN FLIGHT DYNAMICS

5.7.1 Introduction

The 3S orbit will be circular at an altitude of 500 km and inclined 28.5 degrees to the Equator. An analysis has been performed to determine whether or not the 3S would require a propulsion system for stationkeeping at this orbital altitude. Although a 3S propulsion system was primarily considered in this analysis for stationkeeping (i.e., to maintain the 3S at a desired distance from the S/S) the propulsion system could also be used to deploy or retrieve the 3S. The only perturbing force assumed for the analysis was atmospheric drag, which was assumed to act on both the 3S and the S/S. Table 5-12 presents the atmospheric drag assumptions for both the 3S and the S/S. Note that the ballistic coefficient for the S/S is anywhere from 3.6 to 10.8 times that of the 3S, which implies that the S/S orbital altitude will decay more rapidly than the 3S orbital altitude.

Table 5-12
Flight Dynamics Characteristics

Characteristic	3S	S/S
Mass (kg)	2200 to 4600	232000
Drag area (M ²)	5.6 to 8.1	3000
Ballistic coefficient (M ² /kg)	2.75 x 10 ⁻³ to 8.25 x 10 ⁻³	29.74 x 10 ⁻³
Atmospheric density (kg/M ³)	1.25 x 10 ⁻¹² to 4.00 x 10 ⁻¹²	1.25 x 10 ⁻¹² to 4.00 x 10 ⁻¹²

5.7.2 Deployment

Several methods for deploying the 3S to some desired distance behind the S/S were investigated. Initially it was assumed that the OMV would be used as the method for deploying the 3S. A typical scenario envisioned for OMV deployment of the 3S might proceed as follows: the OMV (with the 3S attached) would slowly

back away from the S/S. Once the OMV reached a safe distance behind the S/S, it would raise its apogee, say 10 km. This increase would cause the OMV/3S to drift rapidly behind the S/S. The curve labeled OMV boost in Figure 5-13 shows the separation distance as a function of time for the stated set of parameters. After drifting to the desired distance behind the S/S (assumed to be 463 km (250 n.mi.)), the OMV would lower its apogee 10 km to achieve the same orbit as the S/S, thus holding the separation distance between the 3S and the S/S. The OMV would then release the 3S. Following confirmation of a healthy 3S, the OMV would lower its perigee 10 km, drift back to the S/S, raise its perigee 10 km, and finally dock with the S/S.

An alternative method for deploying the 3S did not include OMV involvement. Because the 3S needs a propulsion system for station-keeping, adding additional propellant would allow the 3S to perform the OMV orbital maneuvers in the previously mentioned scenario. The propulsion system would require up to 6 kg of hydrazine propellant to execute the 10 km apogee raising maneuver, and up to 6 kg to execute the 10 km apogee lowering maneuver. The separation distance as a function of time would be the same as for the OMV deployment (i.e., the curve labeled "OMV Boost" in Figure 5-13). This method may pose a safety problem of 3S propulsion subsystem operation in close proximity to the S/S.

The preferred method for deploying the 3S uses a combination of the two previous methods. The OMV would be used to conduct the proximity operations (i.e., to slowly back away from the S/S) to ensure safety considerations, and to raise apogee 10 km. After the OMV/3S had separated approximately 37 km (20 n.mi.) from the S/S, the OMV would detach from the 3S. The 3S would continue to drift to the desired separation distance, where it would use up to 6 kg of hydrazine propellant from its propulsion system to lower apogee 10 km. Meanwhile, the OMV would have lowered its apogee 20 km, drifted back to the S/S, raised its perigee 10 km, and docked with the S/S. This approach appears to make the most effective use of the OMV, because safety considerations in the S/S proximity are maximized, the overall duration required for the OMV is minimized, and up to 6 kg of additional fuel that 3S would have to carry is eliminated.

An alternative method was considered for deploying the 3S without the involvement of OMV and without the initial apogee raising orbital maneuver by the 3S. This method makes use of the difference in atmospheric drag between the 3S and the S/S. Because the orbital altitude of the S/S decays rapidly more than the orbital altitude of the 3S, just releasing the 3S from the S/S would result in the S/S pulling ahead of the 3S. The curve labeled "drag alone" in Figure 5-13 presents the separation distance as a function of time for the stated set of parameters. Note that a much longer time is required to achieve the desired separation distance and the 3S would have to lower its orbital altitude to that of the S/S

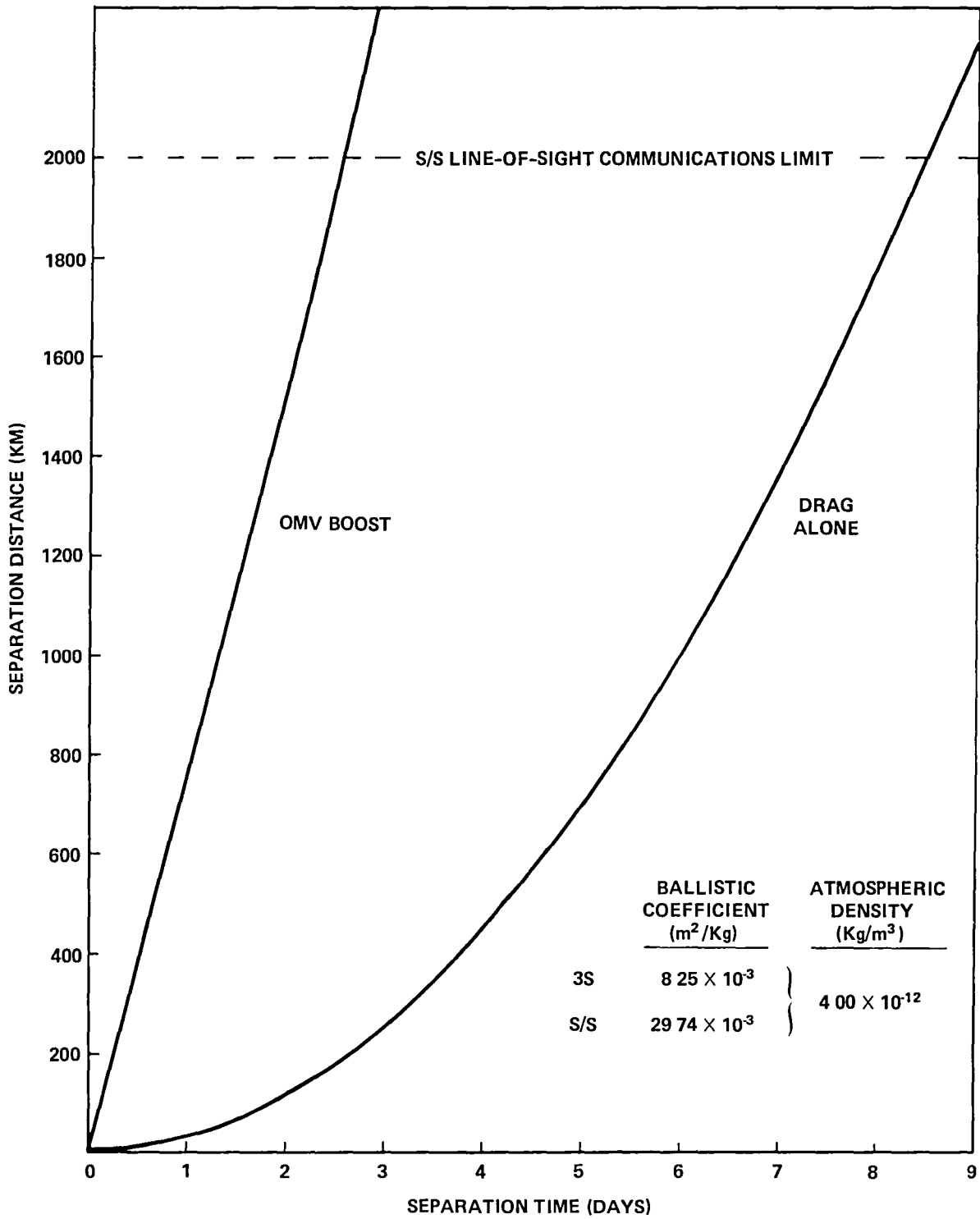

Figure 5-13. Separation Distance Versus Time

when it achieves the desired separation distance. Other methods of deploying the 3S from the S/S were recognized such as spring release and catapult, but were not considered at this time.

5.7.3 Stationkeeping

Assuming that the 3S would be deployed to some desired distance behind the S/S and knowing that the maximum line-of-sight communications limit for the S/S was 2000 km, the differences caused by atmospheric drag between the 3S and the S/S eliminate the possibility that the 3S could remain within 2000 km of the S/S for up to a 3-month mission without a propulsion system. Therefore, a 3S propulsion system was defined only to maintain any desired separation distance for a 3-month mission. (In the strawman system the maximum communications distance is 500 km.) The propulsion system would require up to 52 kg of hydrazine propellant.

Methods were investigated for maintaining the 3S to the maximum acceptable separation of the S/S without using a propulsion system. One method, for example, obviated the constraint that the 3S had to remain behind the S/S. The OMV would deploy the 3S to the desired distance behind the S/S and then lower the 3S orbital altitude below that of the S/S. The 3S would then close in on the S/S, pass beneath the S/S, and continue past the S/S (increasing the separation distance) until the S/S orbital altitude decayed to that of the 3S thereby stabilizing the separation distance. The 3S would retrace its steps closing in on the S/S, passing above the S/S, and continuing past the S/S until the 3S could readjust its orbital altitude and halt the separation. Because this and other methods might place the 3S on a potential collision course with the S/S, they were only given brief consideration and then discarded. The changing location of 3S with respect to the S/S would also require a steerable communications antenna on the S/S, rather than the fixed antenna adapted for the basic 3S system.

5.7.4 Retrieval

Upon completion of the 3S mission, the procedure for retrieving and returning the 3S to the S/S is essentially the reverse of the deployment sequence. In the preferred scenario, the 3S would reduce its perigee by 10 km using approximately 6 kg of hydrazine. This change in perigee would cause the 3S to speed up in relation to the S/S. When the 3S is within 20 miles of the S/S, the OMV would rendezvous with and attach to the 3S, raise its perigee 10 km, and subsequently dock with the S/S. Again the OMV is used in the vicinity of the S/S because of safety considerations. Use of the 3S propulsion system at greater distances from the S/S allows reduced use of the OMV.

5.7.5 Conclusion

The flight dynamics analysis indicates that the 3S must have a propulsion system. If deployed and retrieved by the OMV, the 3S would need up to 52 kg of hydrazine propellant to just maintain a desired separation distance for a 3-month mission. Increasing the amount of hydrazine would increase the usefulness of the 3S by providing it with the ability to deploy or retrieve itself. Future studies should re-examine the deployment, separation maintenance, and retrieval methods in more detail when new requirements, procedures, and safety factors are more defined.

5.8 SPACE STATION SPARTAN PROPULSION SUBSYSTEM

5.8.1 Propulsion System Requirements

The 3S will incorporate an Integral Propulsion System (IPS) to perform orbit adjust maneuvers, slewing, and attitude control as appropriate. In addition, depending on the final scenario selected, the IPS may be required to provide the impulse necessary to move the 3S to operational position, and at the end of the mission to provide the return impulse from operational position to within the vicinity of the S/S where it can be retrieved by the OMV. The various mission scenarios are shown in Table 5-13. Obviously, the OMV could perform the 3S stationkeeping and attitude control functions entirely, but this function would be impractical because of the 1 to 3 month utilization time on-orbit and thermal control aspects of the 3S.

The propulsion system, which will be designed for ease of integration and repair, will have the capability for propellant resupply at the S/S and will use low force thrusters to satisfy ACS requirements.

5.8.2 Propellant Requirements

Table 5-14 shows the propellant requirements (cold gas and liquid hydrazine for a 10,000-pound 3S). Maximum and minimum cases for both a 1-month and 3-month mission were considered.

The maximum IPS propellant load is based on the following scenario (Figure 5-14). The 3S is deployed from the S/S by the MRMS and allowed to drift to a safe distance (approximately 200 feet) from the S/S before enabling the IPS. The 3S propulsion subsystem is used to move 3S to the desired distance from S/S, to stationkeep (for 1 to 3 months), and to return the 3S to the vicinity of the S/S where it can be retrieved by the OMV. Table 5-14 shows that 1234 pounds of nitrogen gas are required for a 1-month mission and 3079 pounds of nitrogen gas for a 3-month mission. Liquid hydrazine requirements are 321 and 843 pounds, respectively.

Table 5-13
Mission Scenarios

3S Separation from S/S	3S Movement to Operational Position	3S Station Keeping	3S Attitude Control	3S Return to Vicinity of Space Station	3S Dock To Space Station
OMV	OMV	IPS	IPS	OMV	OMV
OMV	OMV	IPS	ACS*	OMV	OMV
OMV	IPS	IPS	IPS	IPS	OMV
MRMS	IPS**	IPS	IPS	OMV	OMV
MRMS	IPS**	IPS	ACS*	IPS	OMV
MRMS	IPS**	IPS	IPS	IPS	OMV

*ACS using momentum wheels and magnetics only.

**Safe distance for IPS firing is achieved by allowing the relative drag difference between 3S and S/S to provide a Delta velocity difference.

Table 5-14
3S Propulsion Subsystem
Propellant Requirements

Operating Mode	Propellant Weight (lbs) of Cold Gas/Hydrazine			
	1-Month Mission		3-Month Mission	
	Maximum Propellant Use	Minimum Propellant Use	Maximum Propellant Use	Minimum Propellant Use
Move to operational position	95/26	OMV	95/26	OMV
Delta velocity (Stationkeep)	139/38	139/38	417/114	417/114
Attitude control	690/189	--	2070/567	--
Return to vicinity of S/S	95/26	OMV	95/26	OMV
Subtotal	1073/279	139/38	2677/733	417/114
15% of contingency	161/42	21/6	402/110	480/132
Total (lbs)	1234/321	160/44	3079/843	480/132
kg	561/146	73/20	1399/303	219/60

Notes:

(1) 10,000 pounds 3S
(2) Weight numbers rounded off

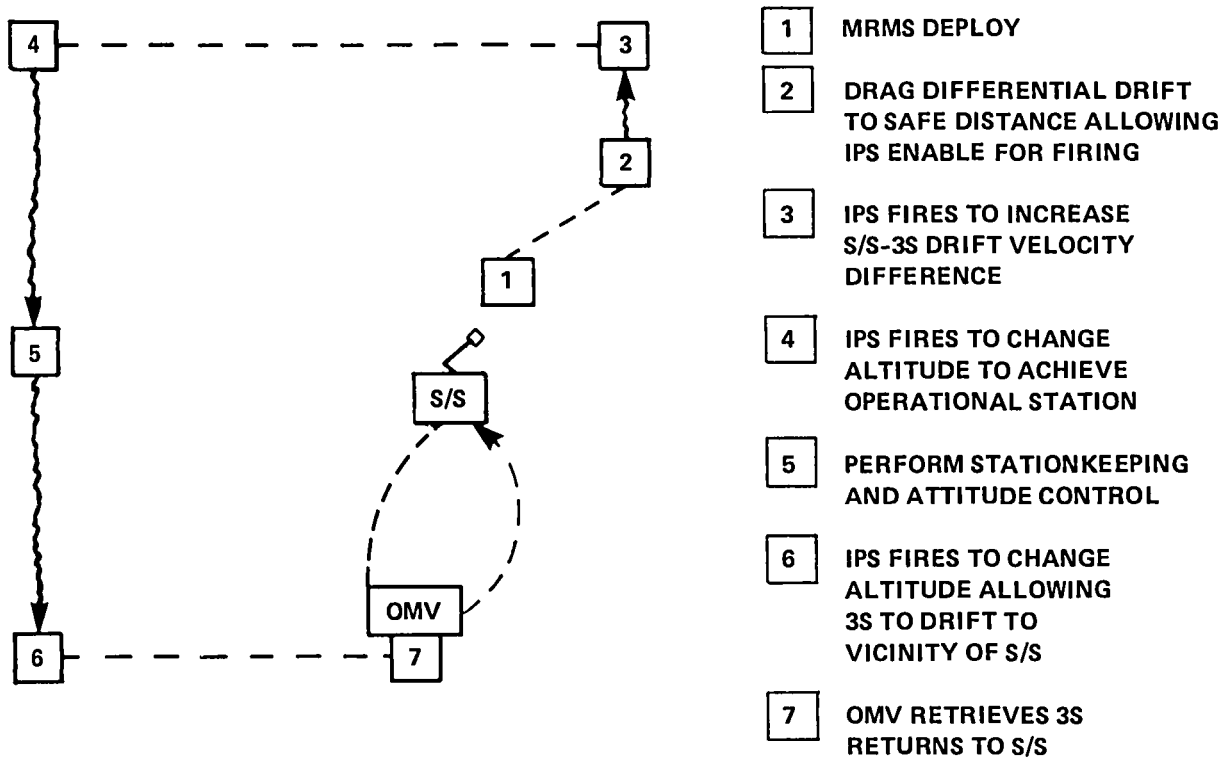

Figure 5-14. Maximum IPS Propellant Requirements Scenario

The basis for the minimum IPS propellant requirement is that the ACS will perform all attitude control functions (the IPS will perform momentum wheel dump, as needed) and the OMV will be used to the maximum practical extent. Therefore, the IPS will be required only for stationkeeping and normal altitude control. Figure 5-15 shows the minimum IPS propellant scenario. Table 5-14 shows that 160 pounds of cold gas is required for a 1-month mission and 480 pounds for a 3-month mission. In terms of liquid hydrazine, the values are 44 pounds and 132 pounds, respectively.

5.8.3 System Design

The IPS will be designed to facilitate off-line fabrication, to ease integration and checkout, and to enhance the capability for on-orbit repair or replacement. In addition, the IPS will be designed for on-orbit resupply at the S/S by a quick disconnect coupling that will be a standard interface.

The IPS will be located in the keel section of the 3S as shown in Figure 5-16. The module provides a central location about the 3S center of gravity for the tanks and thrusters. Eight low thrust (approximately 0.2 lbf) engines will be located as shown to provide primary and redundant orbit adjust maneuvers, in addition to roll, pitch, and yaw control functions. The thrusters are canted to provide torque moment arms and to minimize plume impingement on the 3S surfaces.

5.8.4 Cold Gas Versus Hydrazine

During this effort, it was deemed desirable to compare cold gas and liquid hydrazine systems with respect to sizing of the components and the subsequent effect on propulsion system costs.

Figure 5-17 shows that the basic designs for the two systems are the same except the cold gas system requires a regulator and heavy wall tanks to contain the high pressure (3500 psig) gas. By contrast, the hydrazine system requires an active thermal system to maintain the propellant in the system above 35°F to prevent freezing.

Table 5-15 shows a weight and volume comparison for the minimum and maximum propellant requirements. For a 1-month minimum mission, the cold gas would be less costly than hydrazine although it is heavier and requires a larger volume, neither of which are drivers for this case.

For the maximum propellant requirement, however, the costs would favor the hydrazine system, and furthermore, the volume and weight of the cold gas system would be overwhelming.

If some intermediate requirement were to be considered, the costs of cold gas and hydrazine might be equivalent, but the weight and

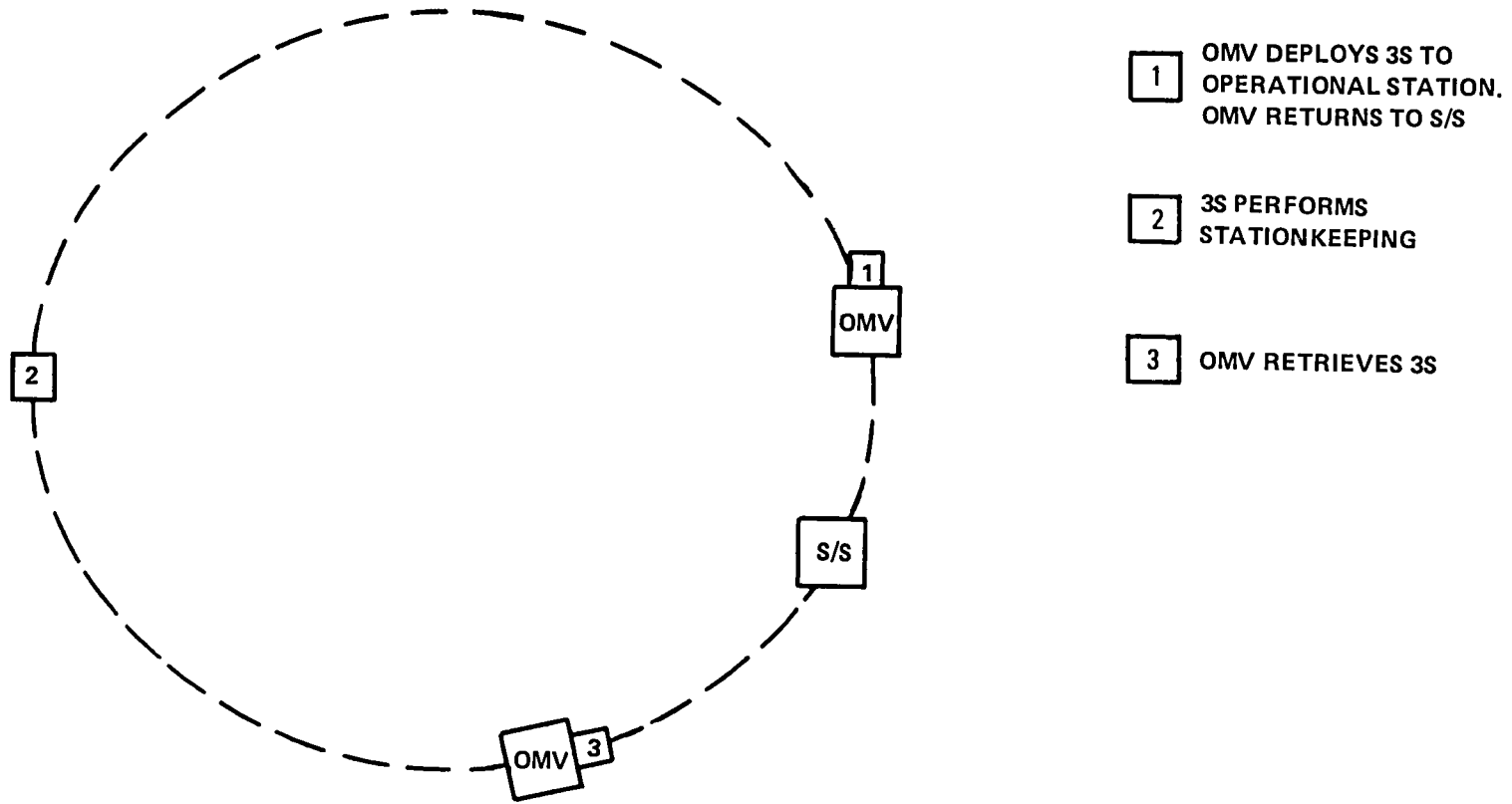
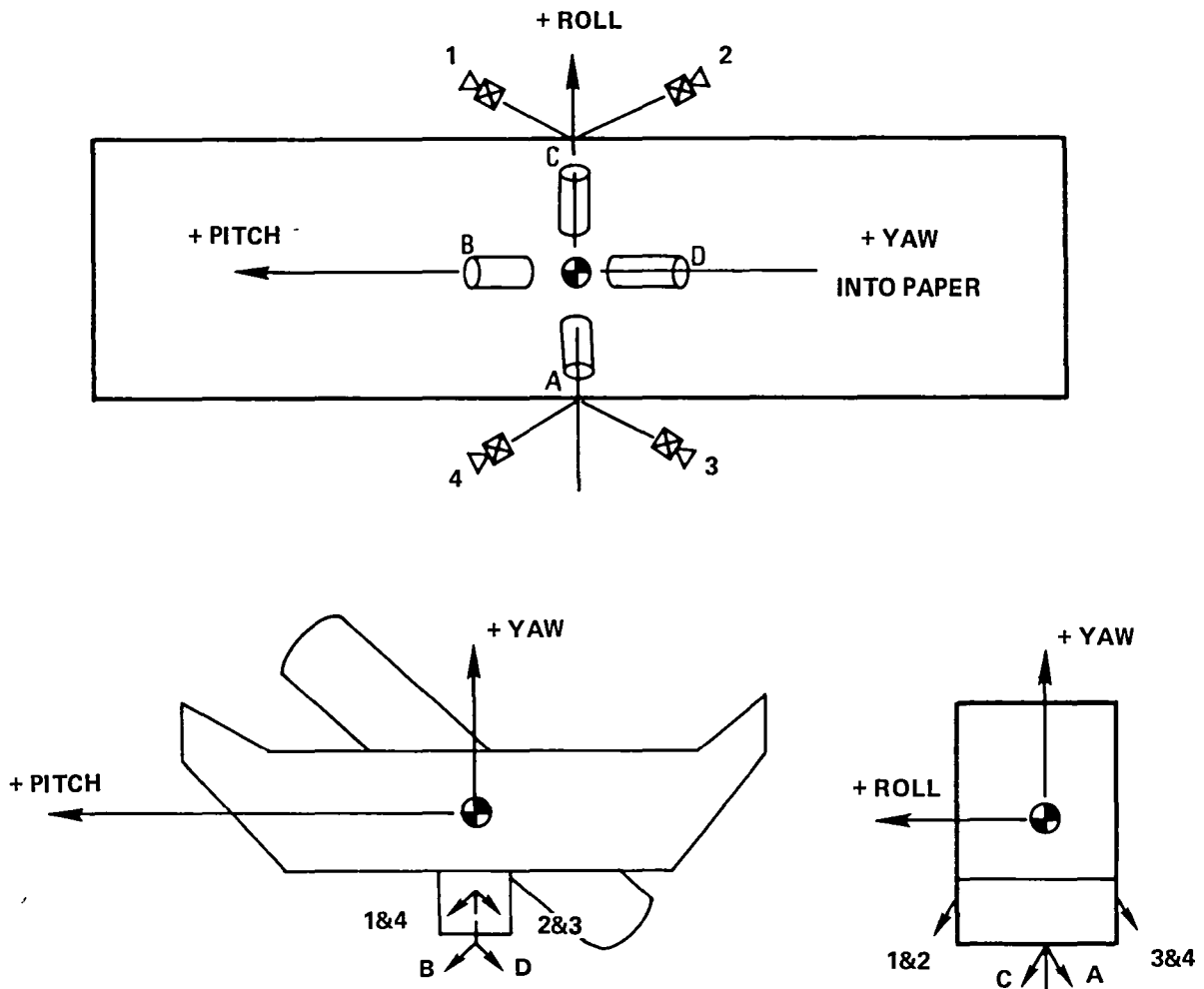

Figure 5-15. Minimum IPS Propellant Requirements Scenario



TORQUE OR FUNCTION	NORMAL	D OR B FAIL	A OR C FAIL	1 OR 3 FAIL	2 OR 4 FAIL
Δv	A+B+C+D	A+C	B+D		
ROLL \pm	B D	4+1 2+3			
PITCH \pm	A C		3+4 1+2		
YAW \pm	1+3 2+4			1 OR 3	2 OR 4

Figure 5-16. 3S Propulsion

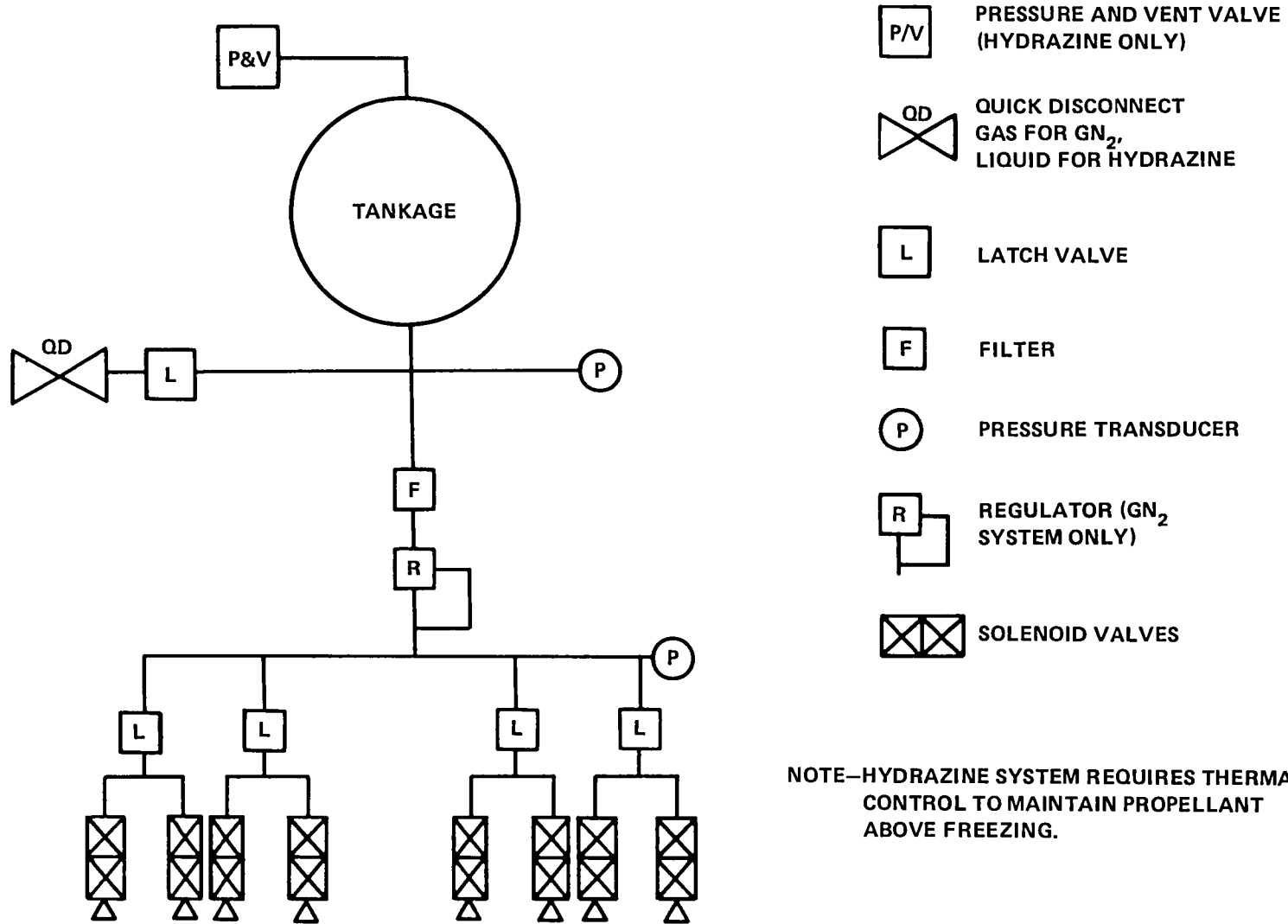

Figure 5-17. Baseline 3S Propulsion System

Table 5-15
3S Propulsion Subsystem
Cold Gas (N₂)/Hydrazine Tradeoffs

Characteristic	Minimum* 1-Month Mission		Maximum** 3-Month Mission	
	Cold Gas(N ₂)	Hydrazine	Cold Gas(N ₂)	Hydrazine
Propellant weight (lbs)	160	44	3079	843
Component weight (lbs)	41	35	41	35
Tank weight (lbs)	219	11	3942	132
Total weight (lbs) (2)	420	90	7062	1010
Number of tanks	1	1	18	3
Tank diameter (in)	34	16.5	34	28
Total tank volume (ft ³)	11.9	1.3	214	19.7
Actual tank volume required (ft ³) (1)	24.8	2.8	446	42.3

*Stationkeeping only (1 month), need inertia wheels for ACS, need OMV for deployment and retrieval

**Deploy, return, stationkeeping, and attitude control (3 months)

Notes:

- (1) Assume cube for each tank
- (2) Support structure weight and cost are not included

volume considerations work in favor of a hydrazine system. In this case, the supporting structure weight and cost would begin to be a major factor.

In addition, it is much easier to increase the propellant capacity of the hydrazine system without much impact on cost, dry weight, or volume. If the 3S weight grows or if additional maneuvers are added at a later date, the propellant volume can be increased by decreasing the ullage volume of each tank. This change in ullage volume acts to increase the blowdown ratio of the system, but avoids the necessity of increasing the number of tanks.

In any event, except for very low total impulse (propellant) requirements, the costs of cold gas and hydrazine are almost equivalent, but weight, volume, and flexibility of the hydrazine system are clearly advantageous for anything beyond a minimum type mission.

For the 3S, a hydrazine system is recommended for both the basic and the strawman systems. Hydrazine is expected to be a common fuel on the S/S.

6. SPACE STATION SPARTAN GROUND SYSTEM

6.1 GROUND SYSTEM DESCRIPTION

The ground system for the 3S consists of the Space Station Spartan ground-support equipment (3SGSE), a Space Station Spartan Operations Control Center (3SOCC) and customer ground-support equipment (CGSE). The ground system is functionally equivalent to that used in the NASA/GSFC Hitchhiker-G program in that it is data transparent to the user. During mission operations, the 3SGSE may be part of the 3SOCC.

To ensure simplicity and ease of instrument integration and on-orbit operations, the 3SGSE and the 3S carrier are designed so that they appear transparent between the CGSE and the instrument. The instrument command generation and data processing are provided by the CGSE for the routine operation, health, and safety of the instrument. Customer control operations can be performed at a control location remote from GSFC. All other on-orbit 3S operations, crew safety, power utilization, communications, attitude timelines, deployment, and retrieval will be accomplished using the 3SGSE/3SOCC.

Figure 6-1 shows the 3S ground system primary elements.

6.2 SPACE STATION SPARTAN GROUND CONTROL CENTER

Communications with 3S will be through the S/S and TDRS. The S/S will serve as a relay for a free-flying 3S to send and receive data from the 3SOCC through the TDRS system (TDRSS). The CGSE will interface directly with the 3SGSE.

The 3SOCC will interface with the institutional support capabilities of the multisatellite operation center located in building 3 at the GSFC. Standard S/S era hardware and software will be used whenever possible. Minimal modifications, as required, will be initiated on behalf of 3S to satisfy mission requirements. The 3SOCC will be capable of handling multiple 3S operations with a single set of ground-control equipment.

The 3S, as a customer of S/S, will interface and use data operations systems and institutional services (now in the planning stages) for customer service. The customer data operations system (CDOS), currently in the planning stage for S/S, will be used by 3S for testing, simulations, and premission operations activities.

6.3 SPACE STATION SPARTAN INTEGRATION AND TEST

The 3S carrier system and the mission-unique payloads require integration and functional testing to be performed on the ground and on orbit. On-orbit integration occurs when the 3S is berthed

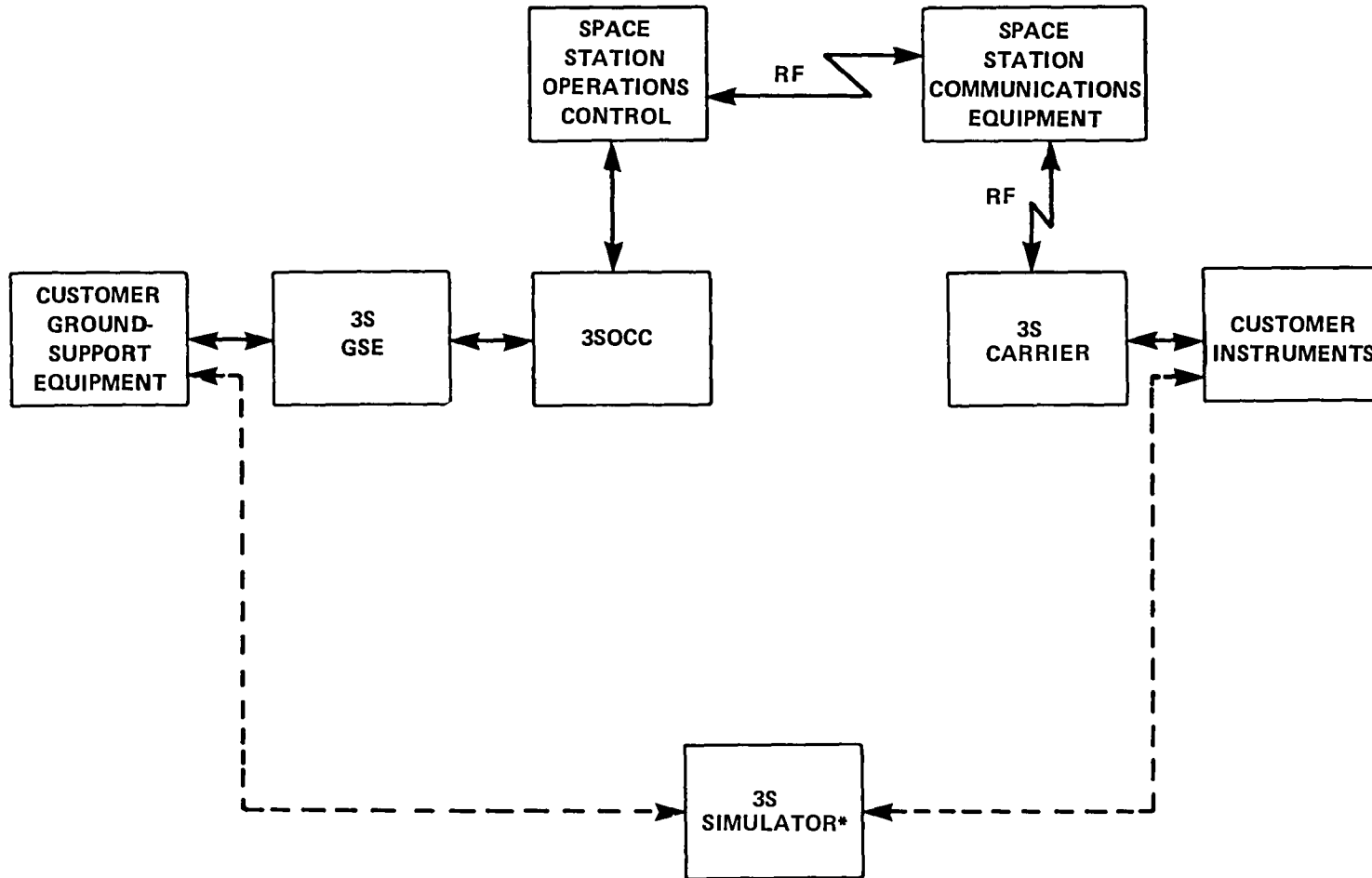

*USED AT THE INSTRUMENT DEVELOPMENT FACILITY

Figure 6-1. Space Station Spartan Ground System

in the S/S servicing area and uses the S/S MRMS, lighting, television, and umbilical services. A shrouded, thermally controlled storage area is required for storing spare 3S subsystem modules and scientific instruments.

6.3.1 Ground Integration and Test

Ground integration and test (I&T) for the 3S program includes the following:

- The ground system requirements for an instrument and a 3S that are developed and launched together
- An instrument launched on the Shuttle that is intended to be integrated with a 3S carrier for the first time on orbit

The elements of the 3S carrier that are integrated and tested as a system include an "across the bay" main structure, the power module, the C&DH module, the attitude control module, the associated thermal control systems, the Shuttle-S/S interfaces, and the instrument interfaces. The main structure and electrical wire harness provide the common integration base for the 3S subsystem modules and instruments. The instruments use standard interfaces and 3S carrier services common to all 3S missions. The subsystem modules are integrated and tested as subsystems before integrated to the carrier structure. To perform realistic subsystem tests, appropriate simulation of the other module interfaces are incorporated. The subsystem modules are integrated onto the carrier structure and harness using the 3SGSE.

The customer-developed hardware (instruments) and software must be thoroughly tested at the customer facility before integration with the 3S carrier. This testing is performed with the use of a 3S carrier simulator and the CGSE. The CGSE is a self-contained system that performs all instrument health/safety checks, instrument quick-look data processing, instrument flight support operations software, and I&T test procedures. The 3S GSE serves as the data and command interface to the 3S carrier system. To maintain system transparency to the CGSE, standard hardware and software interfaces are established between the carrier and the CGSE. Command requests and telemetry data are transmitted between the two ground systems over RS-422 asynchronous links. Commands from the CGSE are accepted by the 3S GSE in a coded format compatible with the test-procedure language. The 3S CGSE test procedure higher order language is derived from or identical to the Standard Test and Operations Language (STOL) used on many present GSFC spacecraft programs. All mnemonic-coded command requests from the CGSE are screened by the 3S GSE for system safety and for customer (instrument only) destination. The CGSE also receives real-time data (when available) in a "transparent" manner. The customer is responsible for processing these data.

The instrument and the CGSE are delivered to the 3S I&T Facility at GSFC and then validated with the 3SGSE. The instrument will be integrated with the 3S carrier system, if it is not already in orbit, otherwise it will be validated within the I&T Facility using a carrier simulator. Typical procedures of the operations timeline planned in orbit for the mission will be executed using the 3SGSE and the CGSE.

The following test activities are required in the I&T Validation Facility:

- Perform electrical interface checks
- Validate appropriate software flow through the carrier system
- Validate data and command formats
- Simulate the mission timeline for Shuttle, S/S, and mission operations
- Provide any astronaut training that may be required
- Perform carrier RF compatibility tests
- Perform combined carrier/instrument electromagnetic compatibility (EMC) tests
- Support other system level environmental testing

6.3.2 Space Station Integration and Test

The on-orbit integration of new instruments, subsystem module replacement, or servicing begins following the retrieval and berthing of 3S with the S/S. Once the 3S is berthed in the spacecraft servicing area of the S/S, a motorized umbilical connector will be mated to a 3S connector located near the berthing mechanism that connects the S/S and the 3S interface unit mounted in the 3S carrier. This hardline connection will allow the crew to deactivate the 3S power system. Other 3S hardline interfaces can then be activated as necessary to use S/S services such as conditioning of the carrier batteries and turn on of the survival heaters. A control panel or workstation terminal operated by the crew in the scientific laboratory module (SLM) provides the necessary readout and control functions for all 3S services from the S/S.

The intended on-orbit instrument deintegration and integration of a new instrument will occur during the 3S powered-down phase. The mechanical attachment fixtures will allow the S/S MRMS to physically lift and move the deintegrated instrument and the re-integrated instrument from and to their berthing stations. The

crew will check physical alignment marks to ensure all mating hardware is in place. If necessary, subsystem modules for the 3S carrier may be replaced during the servicing phase before the installation of the new instrument.

The newly integrated 3S carrier/instrument system is manually powered up by the S/S crew (while berthed in the S/S) through the hardline interfaces. Hardline data and command are provided through the S/S communications system and relayed to the 3S POCC and the CGSE. The CGSE will exercise the newly integrated instrument using precanned checkout procedures. The prerelease checkout is limited in time to a confidence test.

Hardline override/control capability, used for resetting propulsion latch valves, turning off or on instrument power, and controlling 3S carrier power, will ensure the safety of the crew and the S/S system.

6.3.3 On-orbit Checkout

This paragraph briefly discusses the mission timeline required to place, checkout, and initialize the carrier/instrument in mission operations orbit.

The S/S umbilical (3S carrier electrical) connector is demated from the 3S carrier following the confidence test and while berthed with the S/S. If propulsion servicing is necessary, the 3S will be moved to the spacecraft refueling bay. The 3S is then unlatched, lifted out of the berthing attachments using the MRMS, and docked with the OMV. The OMV provides the necessary control to place the 3S at a distance of 20 n.mi. from the S/S. The 3S provides the thrust that places it at a distance no greater than 250 n.mi. from the S/S. If possible, RF communication will be maintained between the 3S and the 3SGSE during the transfer with the OMV. Otherwise RF communication will be established as soon as possible after undocking from the OMV.

The 3S, after release from the OMV, will conduct a safehold attitude maneuver that provides a telemetered signal indicating all is well with the onboard attitude control program. The 3S system is now ready to enter into the "on-orbit checkout" mode.

The 3S carrier subsystems are given an "initial condition" health and safety check through a closed TLM/CMD loop with the 3S GSE. The initial condition test will establish proper attitude and favorable power, data, and command margins. The instrument, once the 3S carrier is declared satisfactory, will be turned on and subjected to a system performance test using the ground data and command link to the CGSE. Note that the customer (PI/user) determines the appropriate instrument operation and approves the move to the next phase of the planned mission mode. The GSFC 3SOCC retains the overall mission operations responsibility and has the necessary override and control authority for the 3S mission.

7. OTHER OPERATIONAL CONSIDERATIONS

7.1 PRELAUNCH AND STS LAUNCH PHASE OPERATIONS

3S prelaunch operations will be conducted as outlined in Figure 7-1. The 3S replacement instrument operations will be conducted as outlined in Figure 7-2.

7.1.1 Operations During STS Launch Phase

During the transit phase from launch to docking with the S/S, 3S will be in a passive mode on board the Orbiter and will require Orbiter power for the heaters.

7.2 STORAGE AT THE SPACE STATION

7.2.1 Thermally Controlled Enclosure

3S requires long term use of a thermally controlled storage area at the S/S for storing replacement instruments and subsystem modules. The entire 3S may also be stored for limited periods between science missions. Thermal control will be required in the S/S service and refueling areas (Sections 2.2 and 3.3).

Before deployment from the S/S the 3S will be taken to the spacecraft service area for deployment of solar arrays and initial checkout. At this time, spare instruments and spacecraft modules will not be available to repair the 3S. If the 3S is not operational, it will be moved to the storage area to await delivery of the necessary spares.

The 3S will not be fully powered up while in storage. The storage area will provide thermal control; resupply heaters will provide backup. The S/S will provide power for the 3S heaters through the umbilical connector. 3S temperature and safety status will be periodically monitored through the umbilical connector. Commands, sent at various times, will perform functions such as instrument module pump down and battery reconditioning.

The first replacement instrument and the first set of 3S subsystem spares will be sent to the S/S in a 3S storage carrier that will remain at the S/S.

Subsequent replacement instruments and spare subsystem modules will be attached to a 3S transport carrier for delivery to the S/S. The transport carrier will not be removed from the Orbiter in order to limit storage area required at the S/S.

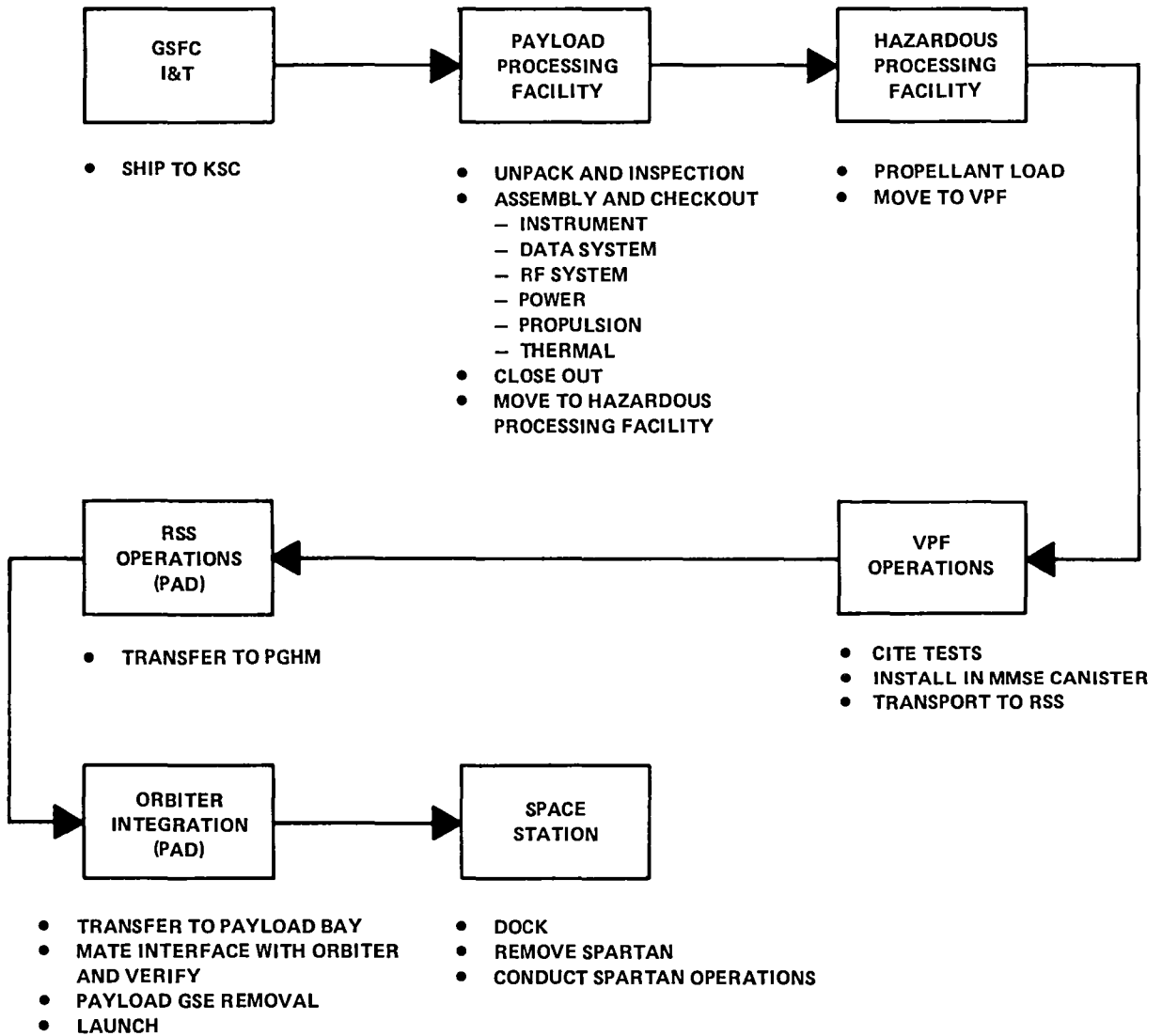

Figure 7-1. Space Station Spartan Prelaunch Operations

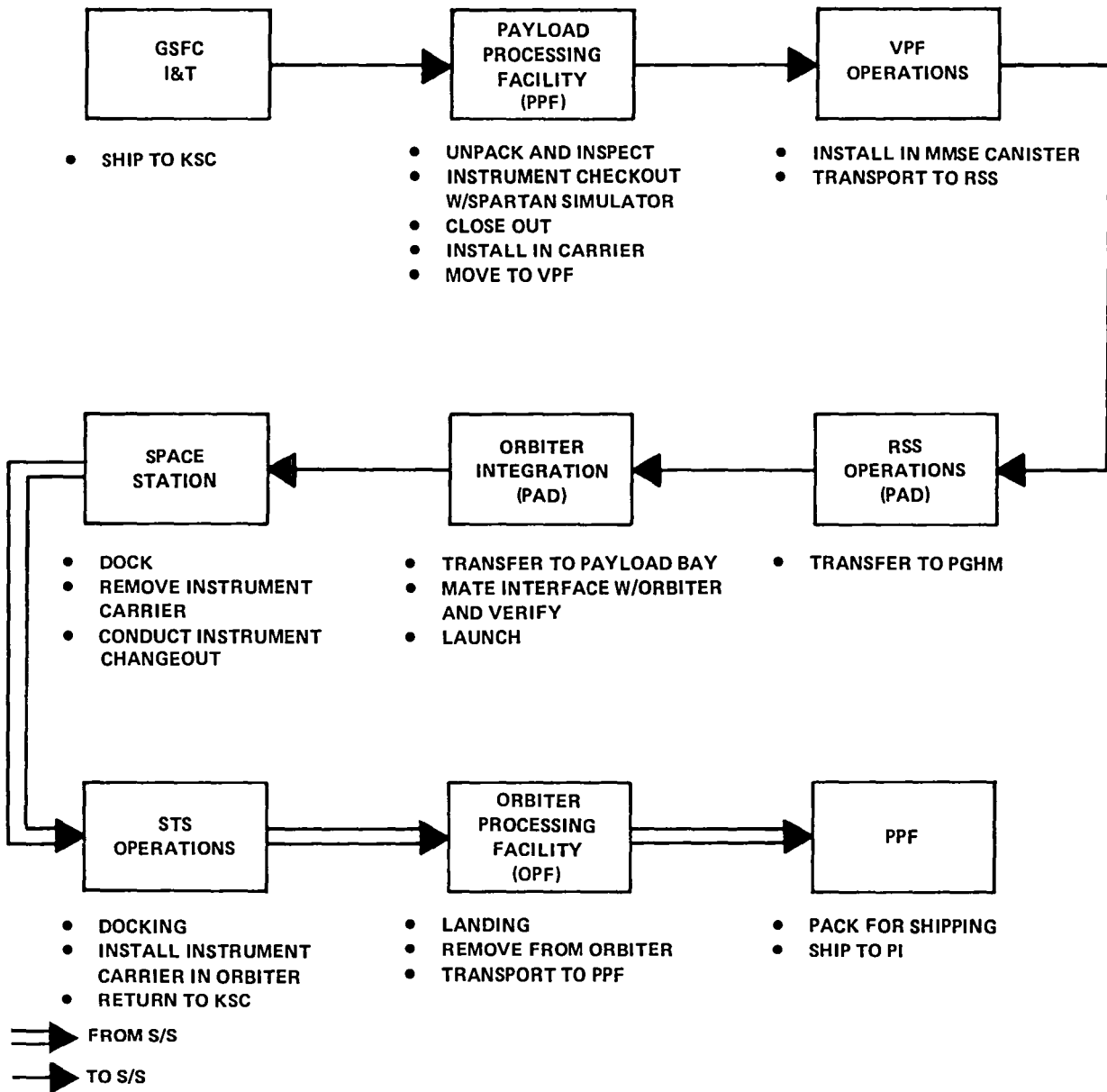

Figure 7-2. Space Station Spartan Replacement Instrument Operations

7.2.2 Mechanical Interface

7.2.2.1 Space Station Spartan Carrier/Storage Carrier--The flight trunnions will be used to support the carriers that are in the storage area. The S/S will provide a means for clamping this interface. Each carrier will have four longeron trunnions and one keel trunnion; however, only two longeron trunnions and the keel trunnion are used to support the carrier on the S/S.

7.2.2.2 Instruments and Space Station Spartan Modules--The instruments and 3S modules will have standard mechanical interfaces. This interface will be the same as that used on the MMS, although the spacing between bolts may be different. The interface consists of two 3/4 inch diameter Acme threaded bolts on the 3S equipment, and floating nut assemblies on the storage area mounting surface. The spacing between the bolts is TBD inches for the instruments and TBD inches for the modules. It may not be necessary to attach both bolts for retention in the storage area.

7.2.3 Electrical Interface

7.2.3.1 3S Carrier--The STS electrical interface, described in paragraph 3.2, will be used in the storage area to provide heater power to the 3S, to monitor temperature and safety data, and to send occasional commands. This interface consists of a retractable SURS connector that will be placed on the S/S side of the interface. Pins will be provided on the 3S side and sockets on the S/S side.

7.2.3.2 Instruments and Subsystem Modules--The electrical interface, a standard G&H connector, will be identical to that used on the carrier. A retraction capability, however, will not be required because the mechanical interface is designed to cause the connector to mate or demate.

7.2.4 Duration

The S/S should be provided with dedicated storage space for the 3S storage carrier and replacement instrument and the set of spare modules. This storage requirement may increase with time because some scientific instruments at the end of flight may remain at the S/S for use in reflly missions.

The storage carrier may remain in the storage area for several years. Each 3S flight will be planned to last up to 3 months. At the conclusion of a flight, 3S will be returned to the S/S for removing the "old" instrument and installing the "new" instrument. The old instrument will be sent to the storage area for subsequent reflight or may return to Earth on the next available Shuttle.

7.2.5 Size

7.2.5.1 Space Station Spartan--3S consists of a bridge-like carrier with subsystem modules mounted on the front surface and the instrument complement embedded in the structure and protruding out the top and bottom to a diameter of 14 feet. The carrier is approximately 5-feet thick, and the subsystem modules are approximately 1 1/2-feet thick. The folded solar array adds another 1 1/2-feet to the thickness. The storage area must therefore provide a cylindrical storage volume that is 15-foot diameter by at least 8-feet thick.

7.2.5.2 Instruments--3S instruments are being designed to fit within a 44-inches diameter by 14-foot length envelope, except for the support electronics (the size of which is undetermined at this time). Some instruments may be smaller than the envelope but none will be larger.

7.2.5.3 Modules--3S subsystem modules will fit within a 4-foot by 4-foot by 18 inches envelope.

7.2.5.4 Handling--The 3S carrier and the spare instruments will be handled by the S/S MRMS. Guide rails will be provided to aid in positioning the instruments, which will have a grapple fixture in a convenient location for MRMS handling. The modules can be handled by either the manipulator or by an EVA crew member. The manipulator, in addition to being mobile, is assumed to have the same dexterity and reach as the Shuttle RMS.

7.2.6 Weight

The thermal mass of the equipment should be considered when designing the storage facility. Storage weight versus time requirements are TBD at this time.

7.2.7 Power

The instruments and modules must be powered periodically when in storage. Heater power will be required in the event of an anomaly in the storage area thermal control system.

7.2.8 Thermal

3S instruments and modules will require a thermally controlled storage area. Note that 3S equipment will have resupply heaters that can control temperature as the 3S is repaired. The 3S may have to be powered off for several days, depending on the extent of the repair effort. 3S should plan for this contingency. The storage temperature requirement is 7 to 24°C.

7.2.9 Telemetry

3S telemetry should be periodically monitored while 3S is in storage. If the thermal control of the storage area is compromised for an extended period of time, it would be desirable to check out the health of all stored equipment without having to mate this equipment to the 3S. This procedure, which could save considerable time when determining if a new set of spare hardware must be brought to the S/S, could also prevent damage to the remainder of the 3S by plugging in a faulty piece of hardware.

7.3 SPACE STATION SPARTAN REPAIR

The modular design of the 3S and the frequent rate that it will visit the S/S make the 3S a likely candidate for contingency servicing at the S/S. The S/S crew could perform many repair activities that would return 3S to working order. These repair activities include:

- Replacement of faulty subsystem modules (ACS, power, C&DH, and propulsion)
- Refurbishment of thermal blankets
- Replacement of degraded solar array panels
- Reposition of solar array if an electromechanical device failure occurs
- Repair of subsystem modules in a pressurized lab

7.3.1 Replacement of Subsystem Modules

The ACS, C&DH, power, and propulsion subsystems will be contained in four modules designed for replacement at the S/S by an EVA crew member. A failure in any of the subsystem modules would require the following scenario. As discussed in previous sections of this report, a spare module should be available on the 3S storage carrier located in the S/S storage bay. If a spare module is not available, the replacement module could be shipped to the S/S by the S/S logistics module. This pressurized supply module is replaced every 90 days with a module stocked with fresh S/S and payload supplies. The 3S subsystem could be mounted in logistics module equipment racks for STS launch. Once the 3S subsystem module is on-orbit at the S/S, it would be transported by IVA and EVA through the equipment airlock to an unpressurized storage site on the S/S.

A temperature controlled, unpressurized storage site will be required with floating-point nuts that the replacement modules can mount directly to using the module retention bolts.

During all launch and S/S handling activities, a protective cover will be in place over the delicate thermal louver blades located on the outer face of each module. In addition, the ACS module will have similar shields for the star tracker shades to protect and block out light that could damage unpowered star trackers. The protective covers will mount to the modules using a "rail and latch" system that provides easy EVA removal and installation without tools.

EVA repair can begin when the inoperative 3S is retrieved and berthed in the S/S servicing area, and the replacement subsystem module and the mission equipment are stored at the S/S. An EVA crew member will gather tools and equipment from storage lockers and traverse to the 3S. The protective covers will be guided onto the failed module and latched secure. The astronaut will enter the end of the module servicing tool (MST) in the module retention fitting (developed for the SMRM) and will disengage both captive bolts holding the module to the 3S structure. The MST, still locked into the module fitting, will be used as a handling device as the crew member pulls the module away from 3S, automatically disconnecting the module's blind mate G&H connector. The inoperative module is carried to the storage area and installed in a temporary storage site by the MST. In the same manner, the astronaut disengages the replacement module from its storage site and installs it on 3S. The protective covers are removed to conclude the EVA. The repaired 3S will be checked out to verify that the new subsystem is operating correctly. (Note that the 3S ACS must be powered on or be shielded from light once the covers are removed.)

7.3.2 Repairing an Inoperative Subsystem Module

The faulty module must be restored to a fully functional capability for use as a spare. Two options can be exercised to accomplish this repair task: the module can be returned to Earth for repair and relaunched to the S/S, or it can be repaired on orbit in a S/S-pressurized lab module if facilities are provided.

If the module is to be returned to Earth, it would be mounted on the 3S transport carrier or in the S/S logistics module and carried by STS to the ground. The 3S subsystem module would be repaired, retested, checked out, requalified, and finally returned to the S/S by the Shuttle. (The initial structural design of the subsystem module would have to allow for the planned lifetime loads of multiple launches and landings.) If the module was repaired on orbit, additional equipment would have to be shipped to the S/S.

7.3.3 Propulsion Subsystem Replacement

The propulsion subsystem replacement scenario will be very similar to that of the other subsystem modules. Some consideration for servicing access to the propulsion subsystem may be necessary,

because it is located on the STS keel side of the 3S (i.e., a keel beam would block access). Protective covers, repair in a pressurized lab module, and transportation in the S/S logistic module are not planned for the propulsion subsystem.

7.4 SPACE STATION SPARTAN SAFETY

A preliminary system safety assessment of the 3S has provided the following findings:

- Radioactive materials are not present (for the strawman payloads).
- Propellants (hydrazine) and flammable materials (thermal blankets) are present. Analysis, design, and research are in the early stages.
- Mercury will not be used in the 3S.
- 3S will not be powered when in the STS. Only survival heater power will be applied to 3S (after cargo bay doors are opened in orbit).
- Multiple safeguards will be used to protect against inadvertent turn on of the propulsion system.
- High-voltage and low-voltage power supplies will have current limit protection.
- The 3S solar array will not be deployed when in the STS cargo bay. However, the design of the 3S allows it to remain within the STS Orbiter bay payload envelope in any operational position.
- The integrity of 3S structure during STS launch, landing, and emergency landing will be verified by environmental testing, fracture control mechanics, and loads analysis.
- Pyrotechnics initiations are not required.

Any changes that may occur, as the 3S continues to develop, will be reflected in future system safety assessments. It has been assumed that if the 3S meets the STS safety requirements then it is safe for operation with the S/S.

The enclosed requirements matrix and payloads hazards report forms (Appendix F) have been completed with the information available at this time.

7.5 SPACE STATION SPARTAN CONTAMINATION CONSIDERATIONS

7.5.1 Space Station Spartan Contamination Control Goals

The contamination-related goals of accommodating 3S within the S/S network and operations include:

- Providing a means for 3S instruments to be placed in orbit, in a relatively low level contamination environment
- Affording the 3S instruments the opportunity to perform, observe, and receive data in a low level contamination environment
- Enabling retrieval, storage, and instrument replacement activities to occur in low level contamination environments

With these goals in mind, instruments (including those with high contamination sensitivities) may use the 3S payload system with a high level of confidence that contamination threats to instrument performance will be significantly lessened.

7.5.2 Contamination Design, Instrumentation, Analysis, and Procedural Requirements

To accomplish the aforementioned environmental goals, a number of design instrumentation, analysis, and procedural requirements must be satisfied. The following list summarizes the various requirements that must be satisfied to provide and characterize the low level contamination environments:

- Low outgassing and low particle generating materials must be used on 3S and S/S systems, noncontamination generating mechanisms must be developed and operations producing contamination must be limited.
- Open/close, actuated aperture covers for sensitive viewing ports should be designed into the 3S system to protect ultrasensitive instruments that are in the vicinity of the Space Shuttle or S/S.
- Contamination covers for the 3S during residence on the S/S should be designed and implemented. These covers will protect the 3S from possible contamination from the S/S environment and from concurrent S/S operations on other payloads (e.g., servicing, refueling, and EVA's).
- S/S contamination monitors should be provided in the service, refueling, and storage areas. These monitors would verify the contamination environment surrounding the 3S during instrument changeout, repair, refueling, and storage activities. Both particulate and molecular contamination

levels should be assessed and recorded before and during these activities.

- Quartz-crystal microbalances (OCM's) should be used as monitoring and status devices on board the 3S. The QCM may be read periodically to assess the contamination level of the 3S instrument and to correlate actual contamination levels with the predictive performance models. Decisions regarding retrieval, possible recleaning, instrument change-out, or continued data taking, can be made based on QCM readings.
- Predictive mass transport models for the "typical" 3S should be developed and updated as QCM data are received. Through the use of these models, instrument data-taking times, attitudes, and instrument performance lifetimes may be evaluated. Models could easily be tailored and input data modified for specific 3S missions. 3S users could use the results of this effort to develop and track mission operations.
- A number of 3S, STS, and S/S procedures and operations may be affected by 3S instrument contamination requirements. Documentation associated with the following mission phases and activities should be reviewed and contamination requirements incorporated as follows:
 - Prelaunch ground handling and environments
 - Special requirements on Shuttle (during launch, and deployment)
 - Location on S/S during storage, integration, and servicing
 - Restrictions on S/S activities (in the vicinity of the 3S)
 - Cleaning operations that may be performed on the 3S during residence on S/S
 - Deployment from S/S
 - OMV retrieval and return to S/S
 - Shuttle descent and recovery operations
 - Propulsion subsystem refueling

7.5.3 Contamination Considerations Summary

Use of the S/S system in conjunction with the 3S payload program appears to be reasonable, convenient, and advantageous from a contamination control perspective. Given that the aforementioned system requirements are assessed and satisfied, 3S instruments could be reasonably assured of low level contamination environments; and through the use of onboard instrumentation, actual contamination levels could be measured and real-time mission performance could be evaluated and adjusted.

7.6 SPACE STATION SPARTAN RELIABILITY, MAINTAINABILITY, AND QUALITY

Reliability, maintainability, and quality assurance activities are planned as an integral part of 3S hardware design, development, integration, and test phases as in earlier STS-deployed Spartans. Reliability and maintainability considerations in the design phase are addressed jointly by design and quality assurance personnel. Although quality consideration during all program phases is the responsibility of quality assurance personnel, the support of dedicated engineering, technician, and fabrication personnel, as in the past, is essential for achieving a successful quality program.

7.6.1 Reliability

Elaborate reliability tradeoff studies are not planned. Attaining an extended orbital lifetime for the 3S may require changes in electronic design (i.e., upgrading parts to Grade 2 of the current GSFC Preferred Parts List). This change relieves the concern associated with the vagaries of internal particles known to exist in the manufacturer's high reliability and lower grade military parts used in the construction of earlier, short duration mission, STS-Spartan hardware. Radiation sensitivity of parts will also have to be given full attention because of the increase in mission duration. In the mechanical design area, longer lifetime mechanisms will require consideration. The possibility of qualifying existing mechanisms for extended lifetime will be thoroughly examined.

The concept of selective redundancy will be applied to emerging designs in these areas where a top level fault tree analysis indicates loss of the ability to retrieve Spartan for return to the S/S or, alternately, to the ground through the Space Shuttle. Redundancy will also be applied where necessary to meet STS and S/S safety requirements.

7.6.2 Maintainability

Maintainability allocations, predictions, and analyses are not planned. To accommodate the ability to changeout Spartan experiments and failed carrier hardware and to replenish depleted gas supplies, emphasis must be placed on designing maintainability early in the program.

Consideration will be given to the tools and the techniques developed by GSFC's Satellite Servicing Project for possible application to 3S hardware design. High fidelity mechanical and electrical simulators will be useful to checkout these tools and techniques. Demonstration of maintenance and changeout abilities in a neutral buoyancy facility with hardware mockups may be necessary.

7.6.3 Quality

The existing STS Spartan quality program has been examined to determine areas where enhancements appear desirable, because a 3S will not be returned frequently to Earth. Current analysis indicates that improvements to the records and record keeping system appear desirable in the areas of:

- Configuration identification and component historical logs--Implementation of a combination computerized/hardcopy file system is contemplated for these items.
- Test procedures should be formalized (i.e., recorded and made available to all test team participants and, when completed, stored for future reference.)
- Documentation of nonconformances, particularly from the beginning of the I&T process, should be undertaken by assurance personnel. Records should be suitably stored for future reference.
- Custodial responsibilities.

One area of future study relates to the degree that 3S software design and checkout might be improved by use of more formal assurance controls.

APPENDIX A

BASIC DEFINITIONS OF THE SPACE STATION SPARTAN (3S)

BASIC DEFINITIONS

For the purposes of this study the following definitions will be utilized:

Spartan: The current low-cost program which utilizes free-flyer systems that are deployed from and retrieved by the STS Orbiter; also the family of free-flyers themselves. Examples are Spartan 101, Spartan 201, 202, 203, etc.

Space Station Spartan (3S): A proposed program of enhanced Spartan free-flyer systems that would operate off of the Space Station (S/S); also the 3S free-fliers themselves (which are carried between Earth and the S/S in the STS Orbiter cargo bay.)

3S Carrier: The 3S free-flyer excluding the science instrument (and its related electronics). It follows therefore that:

$$3S = 3S \text{ carrier} + \text{science instrument}$$

It should be noted that three versions of 3S carriers are discussed in this report. These are:

- 1) A 3S operational carrier capable of taking scientific instruments on free-flight missions. This carrier is generally referred to as 3S carrier (and as 3S when mated with a science instrument).
- 2) A 3S storage carrier used to carry a replacement instrument (and spare 3S subsystems) to the S/S, but which is not capable of conducting science missions. The 3S storage carrier will remain in the S/S storage bay and serve as a holding fixture for instruments and subsystems.
- 3) A 3S transport carrier used to carry 3S instruments between the Earth and the S/S, but which remains in the STS Orbiter bay and is therefore returned to Earth with the Orbiter.

APPENDIX B

COMMENTS REGARDING SPACE STATION SPARTAN BY THE
BANKS SUBCOMMITTEE FOR PLATFORMS

Comments Regarding Space Station Spartan by the Banks Subcommittee for Platforms*

"Certainly low cost Spartan missions must be included in the Space Station. In summary, we find that there is no need for a multi-experiment, co-orbiting platform."

"We must plan on flying a spectrum of single instrument platforms in the same orbit as the Space Station."

"Since the astronomical experiments that will be available in the next 10-20 years vary greatly in size, we will need a spectrum of single instrument platforms that vary in size from Spartans to large observatories such as the Space Telescope."

"In this concept, carriers such as Spartans and Proteus would stay permanently in orbit and experiments would be brought up from the Earth by the Shuttle and stored on the Space Station until carriers become available."

"Historically, many new instruments and observing concepts were developed by small, university space science groups using sounding rockets and balloons. These vehicles have the advantage that they are relatively inexpensive and that they can be flown quickly. This has allowed many generations of graduate students to participate in all phases of space experiments flown from instrument design and construction through flight, data analysis, and publication. We must provide a similar low cost, quick-reaction capability in the Space Station era. Such a capability can be provided by Spartans, GAS Cans, and similar low-cost carriers."

What the Banks Committee is Saying About Spartan**

"Based on the apparent lack of interest in the scientific disciplines towards use of a large, multi-user, co-orbital platform, the summer study participants recommend that NASA re-direct its efforts to provide realistic evaluation of alternative options for co-orbital, free-flying instrument carriers which meet the requirements of disciplines which will need such remote facilities at Space Station IOC."

"The astronomy and astrophysics community requires a spectrum of single instrument platforms ranging in size from Spartans to observatory class facilities."

*Excerpts from Novick Subcommittee draft report, CAL-1549, October 1984

**January 1985 Draft Report

"Essentially all of the astronomy and astrophysics missions, ranging in size from Spartan-class to observatory class (e.g., ST, AXAF, and SIRTf) are well suited to single mission platforms that can be serviced at the Space Station using the orbital maneuvering vehicle."

"We strongly recommend that low cost, small-scale missions must be included in the Space Station concept."

"The smaller missions (Spartans, Explorer, etc.) will require experiment changeout in orbit on a monthly to yearly basis. These smaller platforms should remain in orbit while new experiments are brought up from the ground and old experiments are returned to the ground."

"These opportunities--Spartans, GAS cans, the long-duration exposure facility, and the like--are essential for reducing the time between experiment conception and execution; they provide an excellent match to the basic role of university research."

"Discipline plans for utilization of Space Station should provide explicit alternatives which avoid undue stress to research programs in the event that IOC is substantially delayed."

APPENDIX C

SPACE STATION SPARTAN (3S) STUDY

SPACE STATION SPARTAN (3S) STUDY

STUDY TEAM MEMBERS

<u>RESPONSIBILITY</u>	<u>NAME</u>	<u>GSFC CODE</u>
STUDY MANAGER	JOHN LANE	740
SYSTEMS ENGINEER	JOE SCHULMAN	420
SCIENCE	WERNER NEUPERT	680
MECHANICAL SYSTEM	JIM RAST	741
MODULAR ENGINEERING	JEAN LANE	400
COMMAND & DATA HANDLING	PATRICK CUDMORE	735
R.F. SYSTEM	L. J. ROGERS	727
POWER	JOHN DAY	711
ELECTRICAL INTEGRATION	EARL MOYER	733
ACS	PETE HUI	712
THERMAL	MIKE COYLE	732
GROUND STATION	KERMIT BLANEY	501
SAFETY	FREYA ARROYO	302
QA	BOB WILKINSON	303
CONTAMINATION	NANCY CAROSSO	732
3S REQUIREMENTS ON SPACE STATION	NORM PETERSON	740
SPACE STATION SYSTEMS	JOE DEZIO	400
SPACE STATION SERVICING	BILL WOODRUFF	713
MISSION ANALYSIS	DICK STRAFELLA	554
PROPULSION	AL YETMAN	713
DRAFTING, DESIGN, ART	CHUCK WILLIAMS	SWALES ASSOC.

3S STUDY SCHEDULE

"Kickoff" meeting--January 10, 1985

Visit to John Hopkins University Applied Physics Laboratory to discuss Hopkins Ultraviolet Telescope (HUT) strawman payload--January 11, 1985

Study team briefing by S/S personnel--January 14, 1985

Completion of first phase (first "cut") of 3S Study--February 7, 1985

Review meetings with NASA GSFC Spartan Project and Engineering Directorate personnel--February 11 and 12, 1985

Completion of final phase (final "cut") of 3S Study--April 1, 1985

Final review with NASA GSFC Spartan Project/Engineering Directorate personnel--April 2, 1985

Transmittal of completed 3S Study Final Report to GSFC publications branch--early May 1985

SPECIAL ACKNOWLEDGEMENTS

The 3S Study Team wishes to acknowledge the contributions of Mr. Donald L. Miller, the Deputy Project Manager of the NASA/GSFC Attached Shuttle Payloads (ASP) Project. The 3S study was prepared at the request of Mr. Miller who played a major role in shaping how the study would be conducted.

The 3S Study Team is indebted to members of the Johns Hopkins University (JHU) Applied Physics Laboratory for detailed information that they provided regarding the Hopkins Ultraviolet Telescope (HUT), which was used as a "strawman" payload during the 3S Study. Special thanks is directed to Dr. Knox Long, the HUT Project Scientist and to Mr. Glen Fountain, the HUT Project Manager.

The team also wishes to thank Dr. Ray Cruddace of the Naval Research Laboratory who is Principal Investigator of the High Energy Astrophysics Instrument on Spartan 101 DH for his helpful comments on science instrument support requirements on extended Spartan missions.

APPENDIX D

PRELIMINARY TIMELINE FOR 3S OPERATIONS AT SPACE STATION

3S TIMELINE FOR OPERATIONS AT SPACE STATION

DAY 1

- Shuttle arrives at the Space Station with 3S carrier and instrument 1.
- Remove 3S from cargo bay
- Move 3S to service bay
- Secure 3S in service bay
- Deploy solar array
- Remove louver covers
- Conduct visual inspection

DAY 2

- Checkout 3S from GSFC 3SOCC via TDRSS-S/S

DAY 3

- Move OMV to service bay
- Dock OMV to 3S
- Deploy OMV/3S with MRMS
- OMV places 3S in transfer orbit
- OMV separates from 3S and returns to S/S

DAY 4

- 3S drifts to correct orbital position (range provided by S/S)
- 3S hydrazine system stabilizes orbital position

DAY 5

- 3S begins 3 month scientific mission

DAY 91

- 3S storage carrier arrives at S/S with instrument 2
- 3S storage carrier moved to S/S storage area

DAY 95

- 3S maneuvers to within 20 n.mi. of S/S

DAY 96

- OMV deployed from S/S
- OMV rendezvous with 3S
- OMV captures 3S
- OMV/3S returns to S/S
- OMV/3S grappled by MRMS

- 3S secured in service bay
- OMV returned to its storage area

DAY 97

- Instrument 1 removed from 3S
- Instrument 1 secured in temporary storage location
- Instrument 2 removed from storage carrier
- Instrument 2 installed in 3S
- Instrument 1 installed in storage carrier
- Same sequence repeated for faulty module (if required)

DAY 98

- Move 3S to refueling bay
- Refuel 3S hydrazine system

DAY 99

- Move 3S to service bay
- Checkout 3S from GSFC 3SOCC via TDRSS-S/S

DAY 100

- Deploy 3S with instrument 2 using same scenario from DAY 3

APPENDIX E

CONVERSION OF DROP CENTER BOX SFSS
TO 3S PRIMARY SUPPORT STRUCTURE

CONVERSION OF DROP CENTER BOX SFSS TO 3S PRIMARY SUPPORT STRUCTURE

Minor modifications and additions to the original design of the drop center box SFSS are necessary to make it usable as the 3S primary support structure. These changes, which do not affect performance as an SFSS for the 100 and 200 class Spartans, essentially involve designing certain bulkheads and shear panels to be removable, whereas in the original design these components were permanently installed. This difference will have a negligible impact on cost and production, but will allow relatively easy conversion for specific users. These changes are described in the following paragraphs. Refer to Figures 3-1, 5-1, and 5-2.

The upper shear panels from bulkhead 2 to the end plate 5 is replaced structurally by the Experiment Payload Interface Structure. These panels are designed to be removable on the SFSS to accommodate various payload configurations. Bulkheads 3 and 4 which are removable on the SFSS are removed to accommodate the 3S telescope or other instrument. The removable lower shear panels from bulkhead 3 to end plate 5 are taken off for the 3S version.

The opening left by the removal of the lower shear panels is covered by a prismatic structural enclosure which carries the shear loads normally carried by the removed panels. This enclosure is bolted in place and can be removed from conversion back to the SFSS configuration.

A bulkhead is added that runs diagonally from the upper edge of bulkhead 2 to the lower center of the box where bulkhead 3 was removed. This bulkhead, end plate 1 and the upper, lower and side shear panels between them form a rigid closed box structure. The enclosed bulkhead 2 provides additional rigidity. The rigidity of this portion of the box structure is important in that the ACS module is mounted externally to it and to the optical bench of the science payload interface structure (to which the science instrument is mounted).

(

APPENDIX F
SPACE STATION SPARTAN PAYLOAD HAZARD REPORTS

PAYLOAD HAZARD REPORT		NO. SSS-1
PAYLOAD Space Station SPARTAN		PHASE 0
SUBSYSTEM Survival Heaters	HAZARD GROUP Fire	DATE March 85
HAZARD TITLE Electrical Power Circuit Protection		
APPLICABLE SAFETY REQUIREMENTS: NHB 1700.7A 213--Electrical Systems 219--Flammable Atmospheres		HAZARD CATEGORY X Catastrophic Critical

DESCRIPTION OF HAZARD:

1. Instrument draws excessive current from the power bus, damages STS or S/S electrical system, and ignites wire insulation.

HAZARD CAUSES:

1. Inadvertent turn-on of instrument while in STS or S/S: over-loading wiring and circuits in close proximity to flammable materials.
2. Circuitry not correctly fused and protected.

HAZARD CONTROLS:

1. No flammable materials used in design.
2. 3S electrical system will provide the appropriate (3 independent) safety inhibits for circuit protection. Electrical circuitry is fused.

SAFETY VERIFICATION METHODS:

STATUS OF VERIFICATION:

APPROVAL	PAYLOAD ORGANIZATION	STS
PHASE I		
PHASE II		
PHASE III		

PAYLOAD HAZARD REPORT		NO.	SSS-2
PAYLOAD Space Station SPARTAN		PHASE	0
SUBSYSTEM	HAZARD GROUP Collision/Corrosion	DATE	March 85
HAZARD TITLE Failure of 3S Structure			

APPLICABLE SAFETY REQUIREMENTS: NHB 1700.7A 208-1--Structural Design 208-3--Stress Corrosion	HAZARD CATEGORY	
	X	Catastrophic
		Critical

DESCRIPTION OF HAZARD:

Failure of 3S primary structure and/or components resulting in damage to STS or S/S equipment.

- HAZARD CAUSES:**
1. Material defects, degradation, weld failure, undetected damage
 2. Inadequately design attach fittings or support structure members.
 3. Stress corrosion diminishes load bearing capability.

- HAZARD CONTROLS:**
1. Structural elements designed to ultimate loads with a safety factor ≥ 1.4 (1.4 on yield) for STS.
 2. Strict QA inspection and certification of all materials used.
 3. Material selection and design practices in accordance with MSFC-SPEC-522A (design criteria for controlling stress corrosion cracking).

SAFETY VERIFICATION METHODS:

STATUS OF VERIFICATION:

APPROVAL	PAYLOAD ORGANIZATION	STS
PHASE I		
PHASE II		
PHASE III		

PAYLOAD HAZARD REPORT	NO. SSS-3
------------------------------	--------------

PAYLOAD Space Station SPARTAN	PHASE 0
----------------------------------	------------

SUBSYSTEM	HAZARD GROUP Collision	DATE March 85
-----------	---------------------------	------------------

HAZARD TITLE Sealed Container Ruptures

APPLICABLE SAFETY REQUIREMENTS: NHB 1700.7A 208-7--Sealed Containers	HAZARD CATEGORY	
	<input type="checkbox"/>	Catastrophic
	<input checked="" type="checkbox"/>	Critical

DESCRIPTION OF HAZARD:
 Sealed container ruptures and releases pieces of structure causing damage to STS or S/S.

- HAZARD CAUSES:**
1. Improper design of primary hardware.
 2. Failure of pressure seal.

- HAZARD CONTROLS:**
1. Structure design with a safety factor ≥ 1.5 .
 2. Seals designed to withstand a pressure equal to 1.5 times maximum expected pressure.

SAFETY VERIFICATION METHODS:

STATUS OF VERIFICATION:

APPROVAL	PAYLOAD ORGANIZATION	STS
PHASE I		
PHASE II		
PHASE III		

PAYLOAD HAZARD REPORT		NO. SSS-4
PAYLOAD Space Station SPARTAN		PHASE 0
SUBSYSTEM Thermal Blankets	HAZARD GROUP Fire	DATE March 85
HAZARD TITLE Fire in Cargo Bay or in S/S Storage or Service Areas		
APPLICABLE SAFETY REQUIREMENTS: NHB 1700.7A 209.3--Flammable Materials		HAZARD CATEGORY X Catastrophic Critical

DESCRIPTION OF HAZARD:

Ignition of flammable materials resulting in damage to structure and/or personnel injury.

HAZARD CAUSES:

1. Flammable materials used in thermal blankets will be ignited in a combustible supported atmosphere.
2. Heater temperature sensor inadvertently stays on causing heater temperature to exceed ignition temperature of nearby flammable materials.

HAZARD CONTROLS:

- 1a. Selection of nonflammable materials in accordance with NHB 8060.18.
- 1b. Blankets are constructed of polyester net between mylar film. Exterior is covered with fire-resistant materials.
2. Instruments are not turned on while in STS cargo bay.

SAFETY VERIFICATION METHODS:

STATUS OF VERIFICATION:

APPROVAL	PAYLOAD ORGANIZATION	STS
PHASE I		
PHASE II		
PHASE III		

PAYLOAD HAZARD REPORT		NO. SSS-5		
PAYLOAD Space Station SPARTAN		PHASE 0		
SUBSYSTEM Human Factors	HAZARD GROUP Personnel Injury	DATE March 85		
HAZARD TITLE Personnel Safety				
APPLICABLE SAFETY REQUIREMENTS: NHB 1700.7A 217--Extravehicular Activity		HAZARD CATEGORY		
		<table border="1" style="width: 100%; border-collapse: collapse;"> <tr> <td style="width: 50%;"></td> <td style="text-align: center;">Catastrophic</td> </tr> <tr> <td style="text-align: center;">X</td> <td style="text-align: center;">Critical</td> </tr> </table>		Catastrophic
	Catastrophic			
X	Critical			
DESCRIPTION OF HAZARD:				
<ol style="list-style-type: none"> 1. Laceration/punctures 2. Entrapment of body parts and clothing in moving parts 3. Electrical shock 4. Burns 				
HAZARD CAUSES:				
<p>Sharp edges, exposed electrical wires, surface temperatures, protrusions, and exposed mechanical moving parts could result in personnel injury or damage their support equipment.</p>				
HAZARD CONTRLS:				
<ol style="list-style-type: none"> 1. Exposed edges and corners will be rounded and smooth. 2. Safeguards installation will prevent entrapment of body parts and clothing in moving parts. 3. Insulation/grounding of electrical wires. 4. Provide thermal insulation to heaters and protective clothing to personnel. 				
SAFETY VERIFICATION METHODS:				
STATUS OF VERIFICATION:				
APPROVAL	PAYLOAD ORGANIZATION	STS		
PHASE I				
PHASE II				
PHASE III				

PAYLOAD HAZARD REPORT		NO. SSS-6
PAYLOAD Space Station SPARTAN		PHASE 0
SUBSYSTEM Batteries	HAZARD GROUP Hazardous Materials	DATE March 85
HAZARD TITLE Electrolyte Release		
APPLICABLE SAFETY REQUIREMENTS: NHB 1700.7A 209.1--Hazardous Materials		HAZARD CATEGORY Catastrophic X Critical

DESCRIPTION OF HAZARD:

Rupture of battery and release of electrolyte.

HAZARD CAUSES:

1. High battery over discharge rates producing H₂ gas and increasing pressure
2. Thermal runaway during charge.
3. STS-induced static and dynamic loads.

HAZARD CONTROLS:

1. Verify proper operation of power/battery system prior to retrieval.
2. Test batteries in accordance with NASA Standard "20 Ah Ni-Cd Battery Test Procedure."

SAFETY VERIFICATION METHODS:

STATUS OF VERIFICATION:

APPROVAL	PAYLOAD ORGANIZATION	STS
PHASE I		
PHASE II		
PHASE III		

PAYLOAD HAZARD REPORT		NO. SSS-7
PAYLOAD Space Station SPARTAN		PHASE 0
SUBSYSTEM Propulsion	HAZARD GROUP	DATE March 85
HAZARD TITLE Premature Firing of Liquid Propellant		
APPLICABLE SAFETY REQUIREMENTS: NHB 1700.7A 202.2--Catastrophic Hazard 202.2b--Liquid Propellant		HAZARD CATEGORY Catastrophic Critical
DESCRIPTION OF HAZARD: Firing of liquid propellant prior to reaching a safe distance from STS/Space Station.		
HAZARD CAUSES: Electrical/mechanical malfunction of insulation valve.		
HAZARD CONTRLS: Provide three mechanical/electrical independent flow control devices.		
SAFETY VERIFICATION METHODS:		
STATUS OF VERIFICATION:		
APPROVAL	PAYLOAD ORGANIZATION	STS
PHASE I		
PHASE II		
PHASE III		

**10. STS PAYLOAD SAFETY REQUIREMENTS
APPLICABILITY DESCRIPTIVE DATA**

MATRIX ELEMENT	COMMENTS
1. D,G,Z,GG	See Payload Hazard Report SSS-1
2. G,D	See Payload Hazard Report SSS-2
3. C,F,R	See Payload Hazard Reports SSS-7 and -3
4. U	See Payload Hazard Report SSS-4
5. EE	See Payload Hazard Report SSS-5
6. S	See Payload Hazard Report SSS-6

1 Report No NASA TM-86215		2 Government Accession No		3 Recipient's Catalog No	
4 Title and Subtitle Space Station Spartan Study Final Report				5 Report Date July 1985	
				6 Performing Organization Code 700	
7 Author(s) John H. Lane, Joseph R. Schulman, Werner M. Neupert, et al.				8 Performing Organization Report No 85F0220	
				10 Work Unit No	
9 Performing Organization Name and Address Goddard Space Flight Center Greenbelt, Maryland 20771				11 Contract or Grant No	
				13 Type of Report and Period Covered Technical Memorandum	
12 Sponsoring Agency Name and Address National Aeronautics and Space Administration Washington, D.C. 20546				14 Sponsoring Agency Code	
15 Supplementary Notes					
16 Abstract This document describes the required extension, enhancement, and upgrading of the present Spartan concept in order to conduct operations from the Space Station using the Station's unique facilities and operational features. Known as Space Station Spartan (3S), this free flyer will be deployed from and returned to the Space Station and will conduct scientific missions of much longer duration than possible with the current Spartan. This document also enumerates the potential benefits of a Space Station Spartan. A NASA/GSFC in-house study team was set up in January 1985. The objectives of this study were: <ul style="list-style-type: none"> ● To develop a credible concept for a Space Station Spartan ● To determine the associated requirements and interfaces with the Space Station to help ensure that the 3S can be properly accommodated The results of the study are to be treated as inputs to industry Space Station definition activities. This document is the Final Report.					
17 Key Words (Suggested by Author(s)) Space Station Spartan, Space Station, Spartan, Free Flyer, Space Science, Space Transportation System			18 Distribution Statement Unclassified - Unlimited Subject Category 12		
19 Security Classif (of this report) Unclassified		20 Security Classif (of this page) Unclassified		21 No of Pages 180	22 Price A09

End of Document