

General Disclaimer

One or more of the Following Statements may affect this Document

- This document has been reproduced from the best copy furnished by the organizational source. It is being released in the interest of making available as much information as possible.
- This document may contain data, which exceeds the sheet parameters. It was furnished in this condition by the organizational source and is the best copy available.
- This document may contain tone-on-tone or color graphs, charts and/or pictures, which have been reproduced in black and white.
- This document is paginated as submitted by the original source.
- Portions of this document are not fully legible due to the historical nature of some of the material. However, it is the best reproduction available from the original submission.

(NASA-CR-175786) CONSULTATIVE COMMITTEE FOR
SPACE DATA SYSTEMS. PANEL 1: SUPPORT
Final Report (Operations Research, Inc.)
51 p HC A04/MF A01

N85-27090

CSCL 17B

Unclas
21250

G3/32

ORI

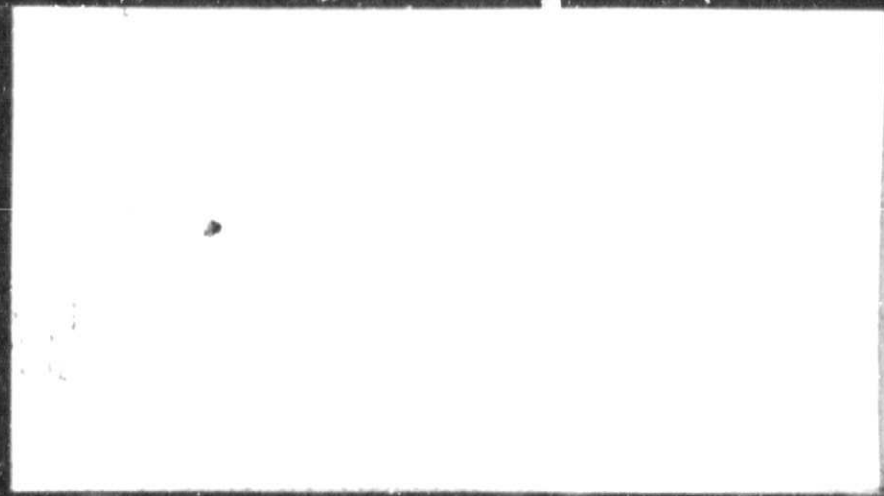

ORI

29 March 1985
Contract No. 956753
Mod 4

**Final Report
Consultative Committee for Space
Data Systems Panel I Support**

**Prepared For:
California Institute of Technology
Jet Propulsion Laboratory
4800 Oak Grove Drive
Pasadena, CA 91109**

6.41 All sub-panel E experts are requested to review their agency's plans for projects requiring telecommand data rates exceeding 2000 bps over the next 5-10 years, to determine the maximum rates needed, to identify the issues to be considered in the design of these telecommand systems and to report these findings at the next meeting.

Mission support requirements for projects planned for launch through 1989 have been reviewed to determine if a requirement exists for a command rate greater than 2000 bps. The reference documents used were:

- 1) Deep Space Network Mission Support Requirements, JPL Doc. 870-14; Rev. D, dated October 1984
- 2) Mission Requirements and Network Support Forecast, GSFC Doc. STDN No. 803, dated February/March 1985

In addition, the Chief of the Advanced Systems Office, Office of Space Tracking and Data Systems, NASA Headquarters was interviewed on March 19, 1985 to determine if Supporting Research and Technology (SRT) tasks are either planned or underway to develop command systems capable of operating at rates above 2000 bps. His office is neither currently funding nor plans to fund such a development.

A review of the reference documents found that only the Shuttle has a requirement for a command rate greater than 2000 bps. The basic Shuttle command rate is 2400 bps prior to encoding and multiplexing as shown in Figure 1.

Shuttle support responsibility during launch and landing operations resides with KSC, during flight operations with JSC/TDRSS, and during TDRSS Emergency with the DSN.

ORIGINAL PART OF POOR QUALITY

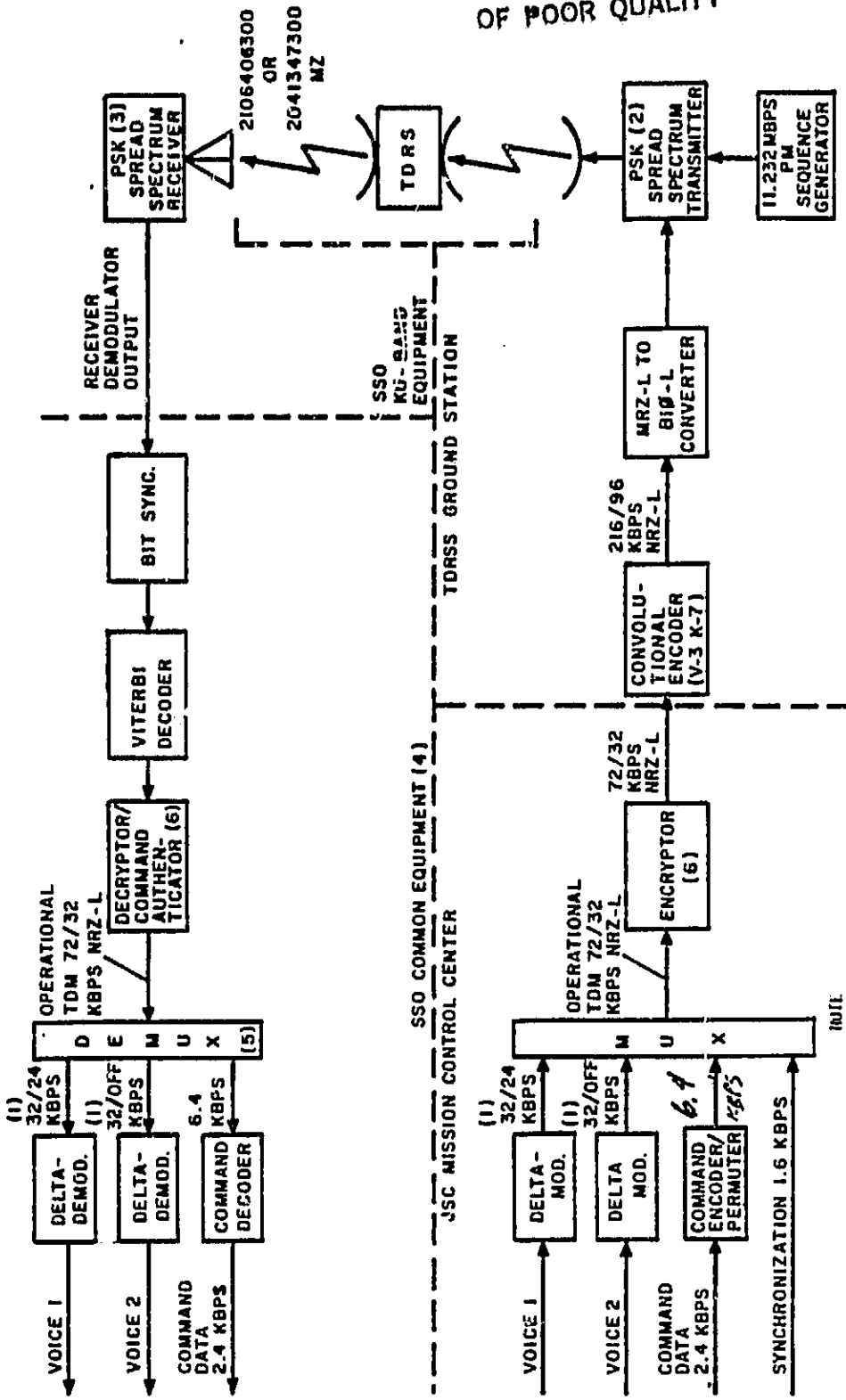

- (1) HIGH OR LOW DATA RATE.
- (2) CAPABLE OF SWITCHING DATA MODULATION ON OR OFF AND INDEFINITELY SWITCHING CARRIER SPREADING ON OR OFF.
- (3) CAPABLE OF OPERATING WITH DATA MODULATION ON OR OFF AND WITH CARRIER SPREADING ON OR OFF.
- (4) SAME EQUIPMENT FOR S-BAND DIRECT UPLINK AND S-BAND FORWARD LINK.
- (5) FRAME SYNC USES 1.6 KBPS SYNCHRONIZATION CHANNEL.
- (6) SYMBOL OF UNENCRYPTED OPERATION.

Figure 1. TDRSS-to-SSO S-band Forward Link Functional Configuration

6.47 Draft Recommendation on Transmitted Frequency Sweep Range on the Earth-to-Space Link for Category B Missions

Considering,

- a) that Category B missions utilize coherent communications techniques in the earth-to-space direction;
- b) that a narrow-band phase-locked loop is used in the spacecraft to coherently detect the received radio frequency carrier;
- c) that it is necessary for the phase-locked loop to acquire the received carrier phase before demodulation can take place;
- d) that there are frequency uncertainties introduced into the link due to oscillator instabilities, doppler, and doppler rate;
- e) that the effect of these frequency uncertainties on the probability of the phase-locked loop acquiring and tracking the received carrier phase and on the time associated with acquisition may be substantially improved by sweeping the frequency of the transmitted carrier;

Recommends

- 1) that the earth station's equipment be capable of varying the nominal transmitted earth-to-space frequency, within symmetrical limits, adjustable in 1.0 Hz increments, to a maximum of 1.0 MHz at 2 GHz and of 5.0 MHz at 8 GHz; and,
- 2) that the transmitted frequency sweep range, in the earth-to-space direction for a Category B mission, be determined in accordance with the procedures contained in Annex I to this Recommendation.

Annex I to Recommendation [6.47]

Procedure to Determine the Transmitted
Frequency Sweep Range on the Earth-to-Space
Link for Category B Missions

The phase of the radio frequency carrier received at the spacecraft is a function of the transmitted phase and the propagation delay. The time rate of change of the propagation delay due to earth rotation, the motion of the earth in its orbit, and the motion of the spacecraft in inertial space induce additional variations in the received carrier phase. The received phase may be approximated by a power series,

$$\phi_R(t) = \phi_0 + (\omega_0 + \omega_d)t + \frac{\omega_a}{2}t^2, \text{ rad} \quad (1)$$

where:

- ϕ_0 : the constant phase (rad);
- ω_0 : the frequency transmitted by the earth station (corrected for the propagation delay) (rad/sec);
- ω_d : The doppler frequency shift (rad/sec); and,
- ω_a : the time rate of change of the doppler shift (rad/sec²).

To compensate for drift in the spacecraft local oscillator, for doppler, and for doppler rate in the earth-to-space direction, the transmitted carrier frequency is adjusted to an offset frequency and slewed at a rate such that the received carrier phase becomes (again, after taking into account the propagation delay),

$$\phi_R(t) = \phi_0 + \hat{\omega}_0 t + (\omega_d - \hat{\omega}_d)t + \frac{\omega_a - \hat{\omega}_a}{2}t^2 \quad (2)$$

where:

- $\hat{\omega}_0$: the estimate of the spacecraft phase-lock loop receiver rest frequency (rad/sec);
- $\hat{\omega}_d$: the estimate of the doppler shift (rad/sec); and,
- $\hat{\omega}_a$: the estimate of the doppler rate (rad/sec²).

The difference between the received phase and the phase of the phase-lock loop is,

$$\epsilon = (\hat{\omega}_0 - \omega_{PLL}) t + (\omega_d - \hat{\omega}_d) t + \frac{\omega_a - \hat{\omega}_a}{2} t^2 + \phi_0 - \phi_{PLL} \quad (3)$$

and the frequency error is,

$$\frac{1}{2\pi} \frac{d\epsilon}{dt} = (\hat{f}_0 - f_{PLL}) + (f_d - \hat{f}_d) + (f_a - \hat{f}_a) t \quad (4)$$

As shown in equation (4), three frequency errors may be identified:

1) the estimate of the phase-lock loop rest frequency, 2) the estimate of the doppler, and 3) the estimate of the doppler rate.

Assuming the errors are independent Gaussian random variables, then the frequency error is also a Gaussian random variable with mean and variance given by,

$$m_\epsilon = m_0 + m_d + m_a \quad (5)$$

$$\sigma_\epsilon^2 = \sigma_0^2 + \sigma_d^2 + \Delta T \sigma_a^2 \quad (6)$$

where:

- m_i : the mean of the i^{th} variable;
- σ_i^2 : the variance of the i^{th} variable; and,
- ΔT : the elapsed time from start to finish of the acquisition procedure (sec).

Estimates of the mean and variance are obtained from an error analysis of spacecraft ephemerides, the orbital geometry, and the measured operating characteristics of the spacecraft receiver oscillators.

With proper adjustment of the transmitted frequency offset (to compensate for spacecraft local oscillator drift and doppler) and the doppler rate compensation, the mean of the frequency error is zero. Consequently, the sweep range, ΔF , may be determined from,

$$P(|f| \leq \frac{\Delta F}{2}) = \int_{-\frac{\Delta F}{2}}^{\frac{\Delta F}{2}} \frac{1}{\sqrt{2\pi}\sigma_c} e^{-\frac{f^2}{2\sigma_c^2}} df \quad (7)$$

The probability that the frequency difference, f , will be within the sweep range $\pm \Delta F/2$ is tabulated in Table I as a function of the standard deviation.

Table I - Probability that the Frequency Difference is within the Sweep Range

$P(f \leq \frac{\Delta F}{2})$	ΔF
.90	$3.28 \sigma_c$
.99	$5.16 \sigma_c$
.999	$6.6 \sigma_c$

It should be noted from equation (6) that the variance of the doppler rate estimate is a monotonically increasing function of time. If the contribution of the term to the variance of the frequency difference is not negligible, then account must be taken of the interrelationship between the sweep rate (see Rec [6.48]) and the sweep range.

6.48 Draft Recommendation on Transmitted Frequency Sweep Rate on the Earth-to-Space Link for Category B Missions

Considering,

- a) that Category B missions utilize coherent communications techniques in the earth-to-space direction;
- b) that a narrow-band phase-locked loop is used in the spacecraft to coherently detect the received radio frequency carrier;
- c) that it is necessary for the phase-locked loop to acquire the received carrier phase before demodulation can take place;
- d) that there are frequency uncertainties introduced into the link due to oscillator instabilities, doppler, and doppler rate;
- e) that the effect of these frequency uncertainties on the probability of the phase-locked loop acquiring and tracking the received carrier phase and on the time associated with acquisition may be substantially improved by sweeping the frequency of the transmitted carrier;
- f) that the maximum sweep rate for a given probability of the phase-locked loop acquiring and tracking the received carrier phase is a function of the communications link parameters, the spacecraft orbit dynamics, and the phase-locked loop design parameters;

Recommends

- 1) that the earth station's equipment be capable of varying the sweep rate within any limits established in Recommendation [6.47], adjustable in 0.10 Hz/s steps, from 0.10 Hz/s to 1.0 MHz/s; and
- 2) that the transmitted carrier frequency sweep rate, in the earth-to-space direction for a Category B mission, be determined in accordance with the procedures contained in Report [XX].

6.49 Draft Recommendation on Spacecraft Receiver Acquisition Procedure for Category B Missions

Considering,

- a) that Category B missions utilize coherent communications techniques in the earth-to-space direction;
- b) that a narrow-band phase-locked loop is used in the spacecraft receiver to coherently detect the received radio frequency carrier and to generate a coherent carrier for transmission in the space-to-earth direction when operating in the coherent mode;
- c) that the radio frequency carrier transmitted by the earth station is offset to compensate for drift in the spacecraft receiver's rest frequency, doppler, and doppler rate;
- d) that the frequency of the carrier received at the spacecraft may differ from the actual receiver rest frequency due to uncertainties in the spacecraft receiver's rest frequency, doppler, and doppler rate;
- e) that the acquisition time of an un-aided phase-locked loop receiver is proportional to the square of the frequency offset;
- f) that the acquisition time may be reduced by sweeping the transmitted carrier frequency through the range of uncertainty;

Recommends,

- 1) that all modulation be removed from the earth station's transmitted carrier during the acquisition sequence;
- 2) that the frequency of the transmitted carrier be swept according to the following sequence (see note 1);

- 2.1) that the carrier frequency at transmitter turn-on be set to the estimated mean rest frequency of the spacecraft receiver minus one-half of the sweep range as determined using the procedures of Recommendation [6.47];
- 2.2) that the carrier frequency be linearly swept to a frequency equal to the estimated mean rest frequency of the spacecraft receiver plus one-half the sweep range at a rate determined using the procedures of Recommendation [6.48];
- 2.3) that upon reaching the upper limit, the sweep is terminated and, to provide time for the phase transients to decay, the carrier frequency is held constant for a period within the range of 10-50 times the reciprocal of the spacecraft receiver phase-locked loop natural frequency (ω_n , rad/sec);
- 2.4) that upon completion of the time specified in paragraph 2.3 above, the transmitted carrier is linearly swept to the estimated mean rest frequency at the rate determined in paragraph 2.2;
- 2.5) that upon completion of this sequence, a minimum period within the range of 10-50 times the reciprocal of the loop natural frequency elapse before applying modulation to the transmitted carrier.

Notes:

- 1) The time and frequency specified in this Recommendation are specified in the spacecraft frame of reference. To obtain the earth station's transmit time, the propagation delay must be subtracted. Similarly, to ensure that the mean received carrier frequency corresponds to the estimated mean rest frequency of the phase-lock receiver, corrections for propagation delay, doppler, and doppler rate must be made.

6.51 Draft Recommendation on Receiver Acquisition Frequency Sweep Range on the Space-to-Earth Link for Category B Missions

Considering,

- a) that Category B missions utilize coherent communications techniques in the space-to-earth direction;
- b) that a narrow-band phase-locked loop is used at the earth station to coherently detect the received radio frequency carrier;
- c) that it is necessary for the phase-locked loop to acquire the received carrier phase before demodulation can take place;
- d) that there are frequency uncertainties introduced into the link due to oscillator instabilities, doppler, and doppler rate;
- e) that the frequency uncertainty introduced by the earth station local oscillator is negligible;
- f) that the effect of these frequency uncertainties on the acquisition time and on the probability of the phase-locked loop acquiring and tracking the received carrier phase may be substantially improved by sweeping the receiver local oscillator frequency;

Recommends

- 1) that the earth station's equipment be capable of varying the nominal receiver center frequency over a maximum range of ± 1.0 MHz at 2 GHz and ± 5.0 MHz at 8 GHz in 1.0 Hz increments; and,
- 2) that the receiver acquisition frequency sweep range, in the space-to-earth direction for a Category B mission, be determined in accordance with the procedures contained in Annex I to this Recommendation.

Annex I to Recommendation [6.51]

Procedure to Determine the Frequency Sweep Range on the Space-to-Earth Link for Category B Missions

1.0 NON-COHERENT MODE

The phase of the radio frequency carrier received at the earth station is a function of the transmitted phase and the propagation delay. The time rate of change of the propagation delay due to earth rotation, the motion of the earth in its orbit, and the motion of the spacecraft in inertial space induce additional variations in the received carrier phase. The received phase may be approximated by a power series,

$$\phi_R(t) = \phi_0 + (\omega_0 + \omega_d)t + \frac{\omega_a}{2}t^2, \text{ rad} \quad (1)$$

where:

- ϕ_0 : the constant phase (rad);
- ω_0 : the frequency transmitted by the spacecraft (corrected for the propagation delay) (rad/sec);
- ω_d : The doppler frequency shift (rad/sec); and,
- ω_a : the time rate of change of the doppler shift (rad/sec²).

To compensate for drift in the spacecraft local oscillator, for doppler, and for doppler rate in the space-to-earth direction, the earth station receiver local oscillator frequency is adjusted to an offset frequency and slewed at a rate such that the received carrier phase becomes (again, after taking into account the propagation delay),

$$\phi_R(t) = \phi_0 + \dot{\omega}_0 t + (\omega_d - \dot{\omega}_d)t + \frac{\omega_a - \dot{\omega}_a}{2} t^2 \quad (2)$$

where:

- $\hat{\omega}_0$: the estimate of the spacecraft transmitter carrier frequency (rad/sec);
 $\hat{\omega}_d$: the estimate of the doppler shift (rad/sec); and,
 $\hat{\omega}_a$: the estimate of the doppler rate (rad/sec²).

The difference between the received phase and the phase of the earth station phase-lock loop receiver is,

$$\epsilon = (\hat{\omega}_0 - \omega_{PLL})t + (\omega_d - \hat{\omega}_d)t + \frac{\omega_a - \hat{\omega}_a}{2}t^2 + \phi_0 - \phi_{PLL} \quad (3)$$

and the frequency error is,

$$\frac{1}{2\pi} \frac{d\epsilon}{dt} = (f_0^{\hat{}} - f_{PLL}^{\hat{}}) + (f_d - \hat{f}_d) + (f_a - \hat{f}_a)t \quad (4)$$

As shown in equation (4), three frequency errors may be identified:

- 1) the estimate of the spacecraft transmitter carrier frequency,
- 2) the estimate of the doppler,
- and 3) the estimate of the doppler rate.

Assuming the errors are independent Gaussian random variables, then the frequency error is also a Gaussian random variable with mean and variance given by,

$$m_\epsilon = m_0 + m_d + m_a \quad (5)$$

$$\sigma_\epsilon^2 = \sigma_0^2 + \sigma_d^2 + \Delta T \sigma_a^2 \quad (6)$$

where:

- m_i : the mean of the i^{th} variable;
 σ_i^2 : the variance of the i^{th} variable; and,
 ΔT : the elapsed time from start to finish of the acquisition procedure (sec).

Estimates of the mean and variance are obtained from an error analysis of spacecraft ephemerides, the orbital geometry, and the measured operating characteristics of the spacecraft transmitter oscillator.

With proper adjustment of the receiver frequency offset (to compensate for spacecraft local oscillator drift and doppler) and the doppler rate compensation, the mean of the frequency error is zero. Consequently, the sweep range, ΔF , may be determined from,

$$P(|f| \leq \frac{\Delta F}{2}) = \frac{1}{\sqrt{2\pi}\sigma_f} \int_{-\frac{\Delta F}{2}}^{\frac{\Delta F}{2}} e^{-\frac{f^2}{2\sigma_f^2}} df \quad (7)$$

The probability that the frequency difference, f , will be within the sweep range $\pm \Delta F/2$ is tabulated in Table I as a function of the standard deviation.

Table I - Probability that the Frequency Difference is within the Sweep Range

$P(f \leq \frac{\Delta F}{2})$	ΔF
.90	$3.28\sigma_f$
.99	$5.16\sigma_f$
.999	$6.6\sigma_f$

It should be noted from equation (6) that the variance of the doppler rate estimate is a monotonically increasing function of time. If the contribution of the term to the variance of the frequency difference is not negligible, then account must be taken of the interrelationship between the sweep rate (see Rec [6.48]) and the sweep range.

2.0 COHERENT MODE

In the coherent operating mode, the carrier frequency transmitted by the spacecraft is related to the spacecraft received frequency by the transponder turn-around ratio, K .

The carrier frequency received by the spacecraft is (for range-rates associated with typical deep space missions),

$$f_{sc/R} = f_T \left(1 - \frac{\dot{r}_u}{c}\right) \quad (8)$$

and the carrier frequency transmitted by the spacecraft is,

$$f_{sc/T} = K f_T \left(1 - \frac{\dot{r}_u}{c}\right) \quad (9)$$

Similarly, the carrier frequency received by the earth station is,

$$f_{Es/R} = f_{sc/T} \left(1 - \frac{\dot{r}_d}{c}\right) = K f_T \left(1 - \frac{\dot{r}_u}{c}\right) \left(1 - \frac{\dot{r}_d}{c}\right) \quad (10)$$

where:

$f_{sc/R}$: carrier frequency received at the spacecraft (Hz);

f_T : carrier frequency transmitted by the earth station (Hz);

\dot{r}_u : the derivative of the range between the transmitting earth station and the spacecraft (meters/sec);

$f_{sc/T}$: carrier frequency transmitted by the spacecraft (Hz);

- K : the spacecraft transponder turnaround ratio (numeric);
 $f_{ES/R}$: carrier frequency received by the earth station (Hz);
 \dot{r}_d : the derivative of the range between the spacecraft and the receiving earth station; and,
 c : the velocity of light.

Carrying out the multiplications in equation (10) and retaining only the first order terms,

$$f_{ES/R} = K f_T \left(1 - \frac{\dot{r}_u}{c} - \frac{\dot{r}_d}{c} \right) \quad (11)$$

The range-rate terms (i.e., \dot{r}_u and \dot{r}_d), are expanded in a power series and truncated after the second term,

$$\dot{r}_u = v_u + \alpha_u t \quad (12a)$$

$$\dot{r}_d = v_d + \alpha_d t \quad (12b)$$

where:

v : the radial velocity (m/sec); and,

α : the radial acceleration (m/sec²).

Substituting equations (12a-b) into equation (11),

$$f_{ES/R} = K f_T \left[1 - \frac{1}{c} (v_u + v_d + (\alpha_u + \alpha_d) t) \right] \quad (13)$$

At the receiving earth station, an estimate of the received frequency, $\hat{f}_{ES/R}$, is generated to align the receiver center frequency with the received frequency. The local estimate is,

$$\hat{f}_{ES/R} = K f_T \left[1 - \frac{1}{c} (\hat{v}_u + \hat{v}_d + (\hat{\alpha}_u + \hat{\alpha}_d) t) \right] \quad (14)$$

The frequency error between the received frequency and the local estimate is,

$$f_{ES/R} - \hat{f}_{ES/R} = - \frac{K f_T}{c} \left[v_u - \hat{v}_u + v_d - \hat{v}_d + (\alpha_u - \hat{\alpha}_u + \alpha_d - \hat{\alpha}_d) t \right] \quad (15)$$

From equation (15) there are four error terms: 1) the uplink velocity, 2) the downlink velocity, 3) the uplink acceleration, and 4) the downlink acceleration.

Assuming the errors are independent Gaussian random variables, then the frequency error is also a Gaussian random variable with mean m , and variance σ^2 , given by,

$$m = \frac{K f_T}{c} \left[m_{v/u} + m_{v/d} + m_{\alpha/u} + m_{\alpha/d} \right] \quad (16a)$$

$$\sigma^2 = \left(\frac{K f_T}{c} \right)^2 \left[\sigma_{v/u}^2 + \sigma_{v/d}^2 + (\sigma_{\alpha/u}^2 + \sigma_{\alpha/d}^2) \Delta T \right] \quad (16b)$$

where:

$m_{v/u}$: mean of the uplink velocity error;

$m_{v/d}$: mean of the downlink velocity error;

$m_{a/u}$: mean of the uplink acceleration error;

$m_{a/d}$: mean of the downlink acceleration error;

$\sigma_{v/u}^2$: variance of the uplink velocity error;

$\sigma_{v/d}^2$: variance of the downlink velocity error;

$\sigma_{a/u}^2$: variance of the uplink acceleration error;

$\sigma_{a/d}^2$: variance of the downlink acceleration error; and,

ΔT : the elapsed time from start to finish of the acquisition procedure.

(It will be noticed that the earth station transmitted frequency, f_T , is assumed to be known precisely. This is a valid assumption for earth stations incorporating atomic frequency standards as the primary frequency source).

Estimates of the mean and variance of the received frequency error are obtained from an error analysis of the spacecraft ephemerides and the orbital geometry. The resulting uncertainty in the received frequency is given by the Gaussian probability density function,

$$p(f) = \frac{1}{\sqrt{2\pi}\sigma} e^{-\frac{(f-k)^2}{2\sigma^2}} \quad (17)$$

Reduction of the mean error to zero (by offsetting the receiver local oscillator) reduces equation (17) to equation (7). The sweep range may then be determined by using equation (7) and Table 1 (after substituting the proper value for the variance).

6.53 Draft Recommendation on Receiver Acquisition Procedure for the Space-to-Earth Link for Category B Missions

Considering,

- a) that Category B missions utilize coherent communications techniques in the space-to-earth direction;
- b) that a narrow-band phase-locked loop is used in the earth station receiver to coherently detect the received radio frequency carrier;
- c) that the uncertainty in the received frequency due to spacecraft oscillator instability (in the non-coherent mode), doppler, and doppler rate is usually large relative to the noise bandwidth of the phase-locked loop receiver;
- d) that the acquisition time for an un-aided phase-locked loop receiver is proportional to the square of the frequency off-set;
- e) that the acquisition time may be substantially reduced by sweeping the receiver local oscillator;

Recommends,

- 1) that the receiver's local oscillator be swept to reduce the phase-locked loop carrier acquisition time;
- 2) that the loop filter of the phase-locked loop be discharged prior to initiating the sweep;
- 3) that the sweep rate be determined using the procedures given in Report [XX];

- 4) that for an increasing (decreasing) doppler frequency, the sweep be initiated at the mean of the estimated received frequency minus (plus) one-half of the sweep range determined using the procedures given in Recommendation [6.51];
- 5) that the difference frequency between the received carrier at the input to the phase-locked loop phase detector and the voltage-controlled oscillator be measured;
- 6) that when the difference frequency reaches zero, the sweep is terminated and the output of the phase detector driving the loop filter is enabled;
- 7) that the coherent lock detector's output be sampled after cessation of the sweep to determine if the loop is locked; and,
- 8) if the loop is not locked, repeat the procedure using revised estimates of the mean received carrier frequency and doppler rate.

6.56 Draft Recommendation on Telemetry Subcarrier Waveform Types for Category B Missions

Considering,

- a) that Category B missions utilize coherent communications techniques to maximize the efficient use of transmitter power;
- b) that telemetry subcarriers are used to minimize the interaction between the earth station carrier tracking loop and the telemetry data;
- c) that it is desirable to minimize the cost and to maximize the reliability of space flight hardware through standardization;
- d) that achieving the cost and reliability objectives are promoted by the use of large scale integrated circuits in the spacecraft transponder;
- e) that different projects have differing requirements that affect the choice of telemetry data rates and subcarrier frequencies;
- f) that a flexible design is desirable in order to satisfy a large range of requirements;
- g) that a programmable digital telemetry system provides greater flexibility with reduced parts count when compared to an analog system;
- h) that a digital subcarrier waveform makes more efficient use of the available transmitter radio frequency power;

Recommends,

that a digital subcarrier be used for the transmission of data for Category B missions.

6.YY Draft Recommendation on Receiver Frequency Sweep Rate on the Space-to-Earth Link for Category B Missions

Considering,

- a) that Category B missions utilize coherent communications techniques in the space-to-earth direction;
- b) that a narrow-band phase-locked loop is used at the earth station to coherently detect the received radio frequency carrier;
- c) that it is necessary for the phase-locked loop to acquire the received carrier phase before demodulation can take place;
- d) that there are frequency uncertainties introduced into the link due to oscillator instabilities, doppler, and doppler rate;
- e) that the effect of these frequency uncertainties on the probability of the phase-locked loop acquiring and tracking the received carrier phase and on the time associated with acquisition may be substantially improved by sweeping the center frequency of the phase-locked loop receiver;
- f) that the maximum sweep rate for a given probability of the phase-locked loop acquiring and tracking the received carrier phase is a function of the communications link parameters, the spacecraft orbit dynamics, and the phase-locked loop design parameters;
- g) that the spacecraft transponder is capable of operating in a non-coherent mode and in a coherent mode; and,
- h) that the selection of the earth station receiver frequency sweep rate depends on the spacecraft transponder operating mode;

Recommends

- 1) that for operations in the non-coherent mode, the earth station receiver frequency sweep rate be determined in accordance with the procedures contained in Report [XX];
- 2) that for operations in the coherent mode;
 - 2.1) [TBD]

DRAFT REPORT [xx]

FACTORS AFFECTING THE CHOICE OF SWEEP RATES
FOR CATEGORY B MISSIONS

1.0. INTRODUCTION

A closed-form solution is not available to determine the composite sweep rate (the sum of the transmitted sweep rate and the uncorrected doppler rate, Hz/s) for a specified acquisition probability at a given carrier-to-noise power ratio at the input to a second-order phase-lock loop receiver.

The procedure described in this Draft Report is based on a combination of linear and non-linear analyses to bound the composite sweep rate for a probability of acquisition greater than 0.90. The development of the procedure starts with an examination of the response of a noise-free, linearized second-order phase-lock loop to a frequency ramp. An expression will be obtained relating the steady-state phase error to the sweep rate and loop parameters. This expression, combined with the results of computer simulations and experimental measurements of the acquisition behavior of phase-lock loops, provides the basis for an empirical curve relating the sweep rate and loop parameters to the acquisition probability.

Next, the variation in the loop parameters for a phase-lock loop preceded by an ideal band-pass limiter is examined to determine the variation in the loop parameters with the carrier-to-noise ratio at the limiter input. The loop parameter variations will in turn affect the sweep rate associated with a specified steady-state phase error.

Finally, a conservative procedure is developed to determine the composite sweep rate to aid the acquisition of second-order phase-lock loop receivers. The application of the procedure to typical category B mission spacecraft transponders and Earth station receivers is demonstrated.

2.0. LINEARIZED PHASE-LOCK LOOP

Figure 1 shows a simplified block diagram of a phase-lock loop. It consists of a sinusoidal phase detector, a loop filter, and a voltage controlled oscillator (VCO). The sinusoidal phase detector produces an error voltage, ϵ , given by,

$$\epsilon = \sin(\phi_i - \phi_o)$$

which for $(\phi_i - \phi_o) \ll 1$ is approximated by,

$$\epsilon \approx \phi_i - \phi_o \quad (1)$$

Using Laplace transforms, the closed-loop response of the phase-lock loop is given by,

$$\frac{\phi_o(s)}{\phi_i(s)} = \frac{K F(s)}{S + K F(s)} \quad (2)$$

For a second-order loop,

$$F(s) = \frac{1 + T_2 s}{1 + T_1 s} \quad (3)$$

Substituting into equation (2),

$$\frac{\phi_o(s)}{\phi_c(s)} = \frac{(1 + sT_2) K / T_1}{s^2 + \frac{1}{T_1} (1 + K T_2) s + \frac{K}{T_1}} \quad (4)$$

Equation (4) may be put into a standard form by using the following substitutions,

$$\omega_n^2 = \frac{K}{T_1} \quad (5a)$$

$$\delta = \frac{\omega_n}{2} \left(T_2 + \frac{1}{K} \right) \approx \frac{\omega_n}{2} T_2 \quad (5b)$$

Therefore,

$$\frac{\phi_o(s)}{\phi_c(s)} = \frac{2\delta\omega_n s + \omega_n^2}{s^2 + 2\delta\omega_n s + \omega_n^2} \quad (6)$$

where:

δ : the loop damping factor, and

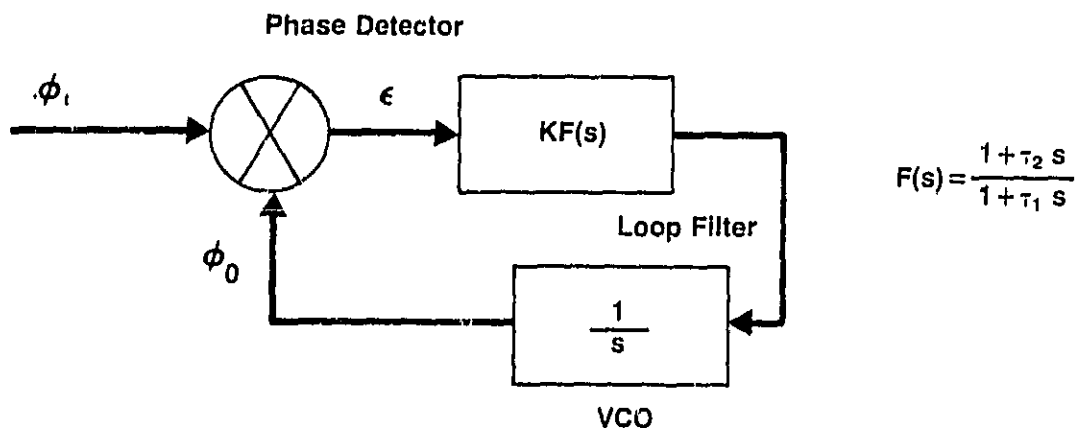

Figure 1. Simplified Model of a Second-Order Phase-Lock Loop

ω_n : the loop natural frequency (rad/s).

Equation (6) is based on the assumption given in equation (5b) that

T_2 is much greater than the reciprocal of the dc loop gain (K). This is a common requirement in the design of second-order phase-lock loops for deep space applications.

The two-sided noise bandwidth of the loop is defined as,

$$2B_{L0} = \frac{1}{2\pi j} \int_{-j\infty}^{j\infty} \left| \frac{\phi_o(s)}{\phi_c(s)} \right|^2 ds \quad (7)$$

Substituting and performing the integration yields,

$$2B_{L0} = (\zeta + 1/4\zeta) \omega_n, \text{ Hz} \quad (8)$$

for the large dc loop gain case.

With these preliminaries, the phase error of a second-order phase-lock loop may now be derived in terms of the loop natural frequency, damping factor, and sweep rate.

2.1 PHASE ERROR IN RESPONSE TO A LINEAR SWEEP

Using equations (1) and (6), the Laplace transform of the phase error in terms of the loop parameters and the input phase is given by,

$$E(s) = \frac{s^2}{s^2 + 2\delta\omega_n s + \omega_n^2} \phi_c(s) \quad (9)$$

For a linear frequency ramp,

$$\phi_c(s) = \mathcal{L}\left[\frac{\Delta\dot{\omega}}{2} t^2\right] = \frac{\Delta\dot{\omega}}{s^3} \quad (10)$$

where:

$\mathcal{L}[\]$: indicates the Laplace transform of the argument, and

$\Delta\dot{\omega}$: the slope of the linear frequency ramp (rad/sec²)

Substituting equation (10) into (9) and taking the inverse transform yields,

$$E(t) = \frac{\Delta\dot{\omega}}{\omega_n^2} - \frac{\Delta\dot{\omega}}{\omega_n^2} e^{-\delta\omega_n t} \left[\cos\sqrt{1-\delta^2}\omega_n t + \frac{\delta}{\sqrt{1-\delta^2}} \sin\sqrt{1-\delta^2}\omega_n t \right], \quad \delta < 1 \quad (11a)$$

$$E(t) = \frac{\Delta\dot{\omega}}{\omega_n^2} - \frac{\Delta\dot{\omega}}{\omega_n^2} e^{-\omega_n t} [1 + \omega_n t], \quad \delta = 1 \quad (11b)$$

$$\epsilon(t) = \frac{\Delta \dot{\omega}}{\omega_n^2} - \frac{\Delta \dot{\omega}}{\omega_n^2} e^{-\delta \omega_n t} \left[\cosh \sqrt{\delta^2 - 1} \omega_n t + \frac{\delta}{\sqrt{\delta^2 - 1}} \sinh \sqrt{\delta^2 - 1} \omega_n t \right], \quad \delta > 1 \quad (11c)$$

The significant feature of equations (11a-c) is the steady-state phase error term, $\Delta \dot{\omega} / \omega_n^2$. Using this result from the linearized analysis, it may be argued, for the case of a sinusoidal phase detector, that an absolute upper bound on the sweep rate must be such that the steady-state phase error not exceed $\pi/2$ radian. Thus,

$$\frac{\Delta \dot{\omega}}{\omega_n^2} < \frac{\pi}{2}$$

A tighter bound has been derived for the case of a high-gain, noise free second-order loop, with a loop damping factor of 0.707 and a sinusoidal phase detector. The probability of lock as a function of the normalized sweep rate is shown in Figure 2. From the figure it is clear that the upper bound on the sweep rate to ensure lock with probability 1.0 is,

$$\frac{\Delta \dot{\omega}}{\omega_n^2} < \frac{1}{2} \quad (12)$$

Figure 3 shows the relationship between the sweep rate, probability of lock and the loop damping factor. The significance of the figure lies in the fact that the acquisition probability increases with an increase in the loop damping factor. As will be shown in Section 3, the loop damping factor

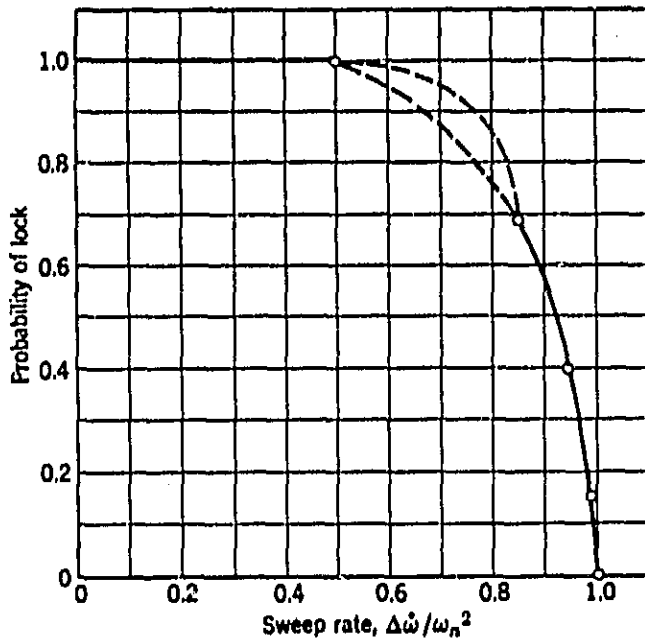

Figure 2. Probability of Sweep Acquisition. Second-Order Loop;
 $\delta = 0.707$; No Noise.

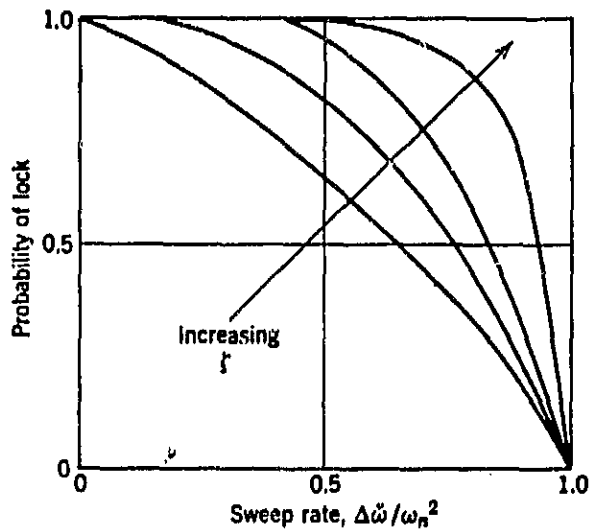

Figure 3. Probability of Sweep Acquisition Showing Effect of Damping.

and the loop natural frequency both increase with the carrier-to-noise ratio for a phase-lock loop preceded by a bandpass limiter.

Extension of this result to phase-lock loops in the presence of noise has been made on the basis of computer simulation and experimental measurements. The general result given is of the form,

$$\Delta f_{90}^{\circ} = A \left(1 - \frac{B}{\sqrt{\rho}} \right) \omega_n^2, \text{ Hz/sec} \quad (13)$$

where:

Δf_{90}° : the maximum sweep rate for a 0.90 probability of acquisition (Hz/sec);

A : a constant in the range of $1/4\pi$ to $1/2\pi$;

B : a constant between 1 and 2; and,

ρ : carrier-to-noise ratio in the tracking loop noise bandwidth (numeric).

Examination of equation (13) indicates that the sweep rate must be decreased as the carrier-to-noise ratio in the loop bandwidth gets smaller; and that acquisition becomes increasingly doubtful at a carrier-to-noise ratio less than 6 dB (corresponding to $B = 2$).

Thus, a conservative estimate of the maximum sweep rate consistent with an acquisition probability of 0.90 for a loop with a damping factor of 0.707 is,

$$\Delta \dot{f}_{90} = \frac{1}{4\pi} (1 - 2/\sqrt{e}) \omega_n^2, \text{ Hz/sec} \quad (14)$$

In Section 4, a similar expression for maximum sweep rate will be presented which constrains the mean steady-state phase error.

3.0. PHASE-LOCK LOOP RECEIVER WITH A BANDPASS LIMITER

A model of a phase-lock loop receiver incorporating a bandpass limiter preceding the phase-lock loop is shown in Figure 4. For this implementation, which is typical of phase-lock loop receivers used for deep space missions, account must be taken of the effect the bandpass limiter on the loop performance. The primary effect of the limiter is on the dc loop gain; there is a secondary effect of about 0.25 dB degradation of the carrier-to-noise density ratio at the input to the phase detector for a carrier-to-noise ratio less than 0 dB at the input to the limiter.

The gain variation comes about as a consequence of the negative carrier-to-noise ratio (dB) at the input to the limiter and the constant output power characteristic of the limiter; this is the so-called limiter suppression factor and is closely approximated by,

$$\alpha = \sqrt{\frac{0.7854 \rho_i + 0.4768 \rho_i^2}{1 + 1.024 \rho_i + 0.4768 \rho_i^2}} \quad (14)$$

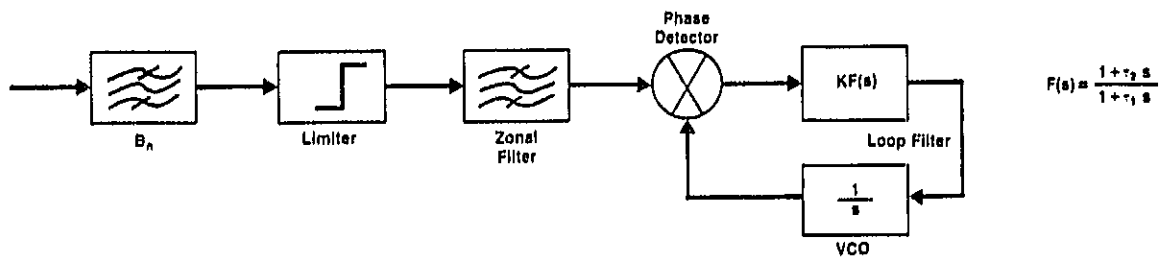

Figure 4. Model of a Second-Order Phase-Lock Loop
Preceded by a Bandpass Limiter

where, ρ_i is carrier-to-noise ratio at the input to the limiter. Figure 5 shows the variation of $20 \log \alpha$ as a function of $10 \log \rho_i$.

Incorporating the limiter suppression factor, α , into equation (4) yields for the linearized closed-loop transfer function,

$$\frac{\phi_o(s)}{\phi_c(s)} = \frac{(1 + s\tau_2) \alpha K / \tau_1}{s^2 + \frac{1}{\tau_1} (1 + \alpha K \tau_2) s + \frac{\alpha K}{\tau_1}} \quad (15)$$

Putting equation (15) into the standard form, as was done previously, requires the following substitutions,

$$\omega_n^2 = \frac{\alpha K}{\tau_2} \quad (16a)$$

$$\zeta = \frac{\omega_n}{2} \left(\tau_2 + \frac{1}{\alpha K} \right) \approx \frac{\omega_n}{2} \tau_2 \quad (16b)$$

At this point it is convenient to express the loop natural frequency and damping factor in terms of their design values at a specified limiter suppression factor,

$$\omega_n^2 = \omega_{n_0}^2 \frac{\alpha}{\alpha_0} \quad (17a)$$

$$\zeta = \zeta_0 \sqrt{\frac{\alpha}{\alpha_0}} \quad (17b)$$

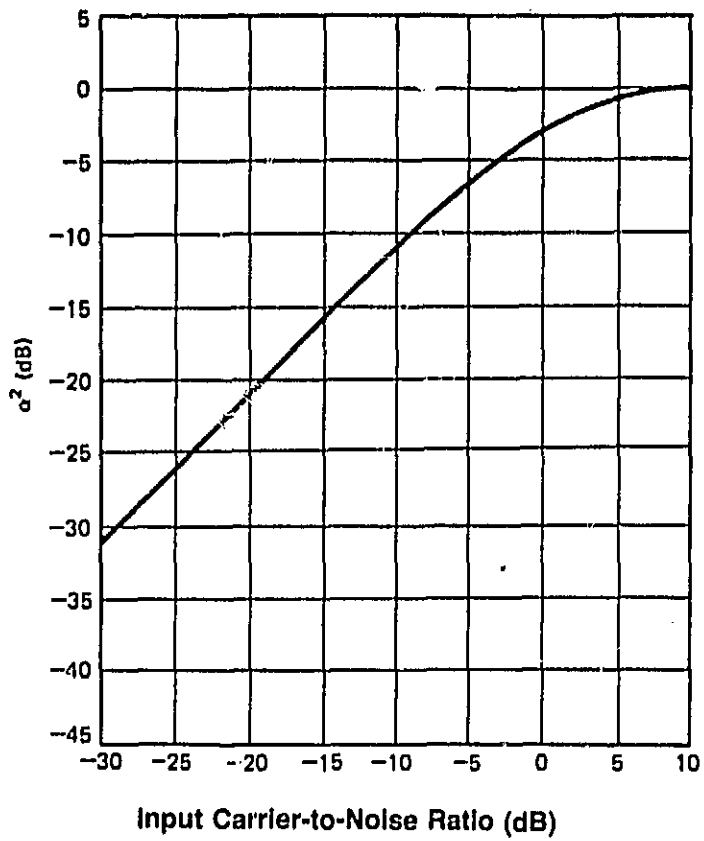

Figure 5. Limiter Suppression Factor

Reference to Figure 5 and equations (17a and b) indicate that the parameter that governs sweep rate (ω_n) and the probability of acquisition for a given sweep rate (δ) are both monotonically increasing functions of the limiter suppression factor.

4.0. CONSTRAINED PHASE ERROR SWEEP RATE

From the results given by equations (11a-c) and (17a-b), a sweep rate may be determined for which, once the loop has locked, the steady-state phase error does not exceed a specified value. This constrained phase error approach will provide a more conservative value for sweep rate; and simultaneously will provide a probability greater than 0.90 of the loop acquiring and maintaining lock.

The steady-state phase error from equations (11a-c) is,

$$\epsilon = \frac{\Delta \dot{\omega}}{\omega_n^2}, \text{ rad}$$

which is equivalent to,

$$\epsilon_d = \frac{180}{\pi} \frac{\Delta \dot{\omega}}{\omega_n^2}, \text{ deg} \quad (18)$$

Solving equation (18) for $\Delta\dot{\omega}$ and noting that $\dot{f} = \Delta\dot{\omega}/2\pi$ gives,

$$\dot{f} = \frac{1}{360} E_d \omega_n^2, \text{ Hz/sec} \quad (19)$$

Finally, substituting equation (17a) into equation (19) yields the sweep rate for a constrained steady-state tracking phase error,

$$\dot{f} = \frac{1}{360} E_d \omega_{n0}^2 \frac{\alpha}{\alpha_0}, \text{ Hz/sec} \quad (20)$$

To provide some measure of confidence in the solution of the sweep rate and constrained steady-state tracking phase error at low carrier-to-noise ratio in the loop, two curves have been derived which relate the closed loop threshold to the static phase error, and the closed loop carrier level required to maintain 99.9% of the phase noise errors at less than 90 degrees. These curves are given in Figure 6.

Using equations (14) and (20) in combination with Figure 6, it is possible to compute the sweep rate as a function of the constrained steady-state tracking phase error and to identify operating regions for which the phase-lock loop will acquire and track the received carrier with probability exceeding 0.90.

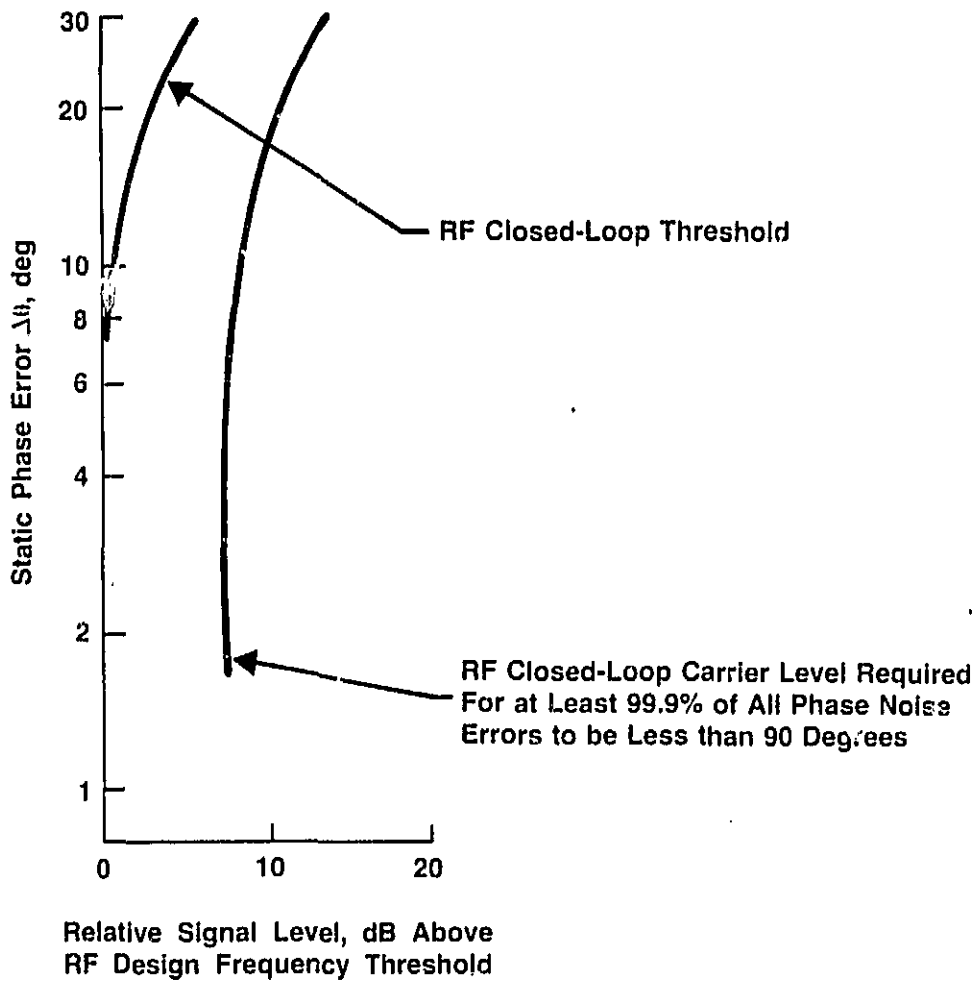

Figure 6. RF Closed-Loop Threshold and Closed-Loop Carrier Level Required for at Least 99.9% of all Phase Noise Errors to be Less than 90 Degrees as a Function of the Static Phase Error.

5.0. EXAMPLE SWEEP RATE CURVES

5.1 SPACECRAFT TRANSPONDER SWEEP RATE

Sweep rate curves given in Figure 7 are based on the following assumptions:

- o The phase lock loop design point is 0 dB carrier-to-noise ratio, ρ_0 , in the phase-lock loop receiver noise bandwidth;
- o $2B_{LO} = 18$ Hz;
- o $\delta = 0.707$; and,
- o Pre-limiter filter is a single-pole filter with a 3 dB bandwidth (B_3) of 3 kHz.

The single-sided carrier-to-noise density at the input to the phase-lock loop is,

$$\frac{S}{\eta_0} = 2B_{LO}\rho_0, \quad \text{Hz}^{-1} \quad (21)$$

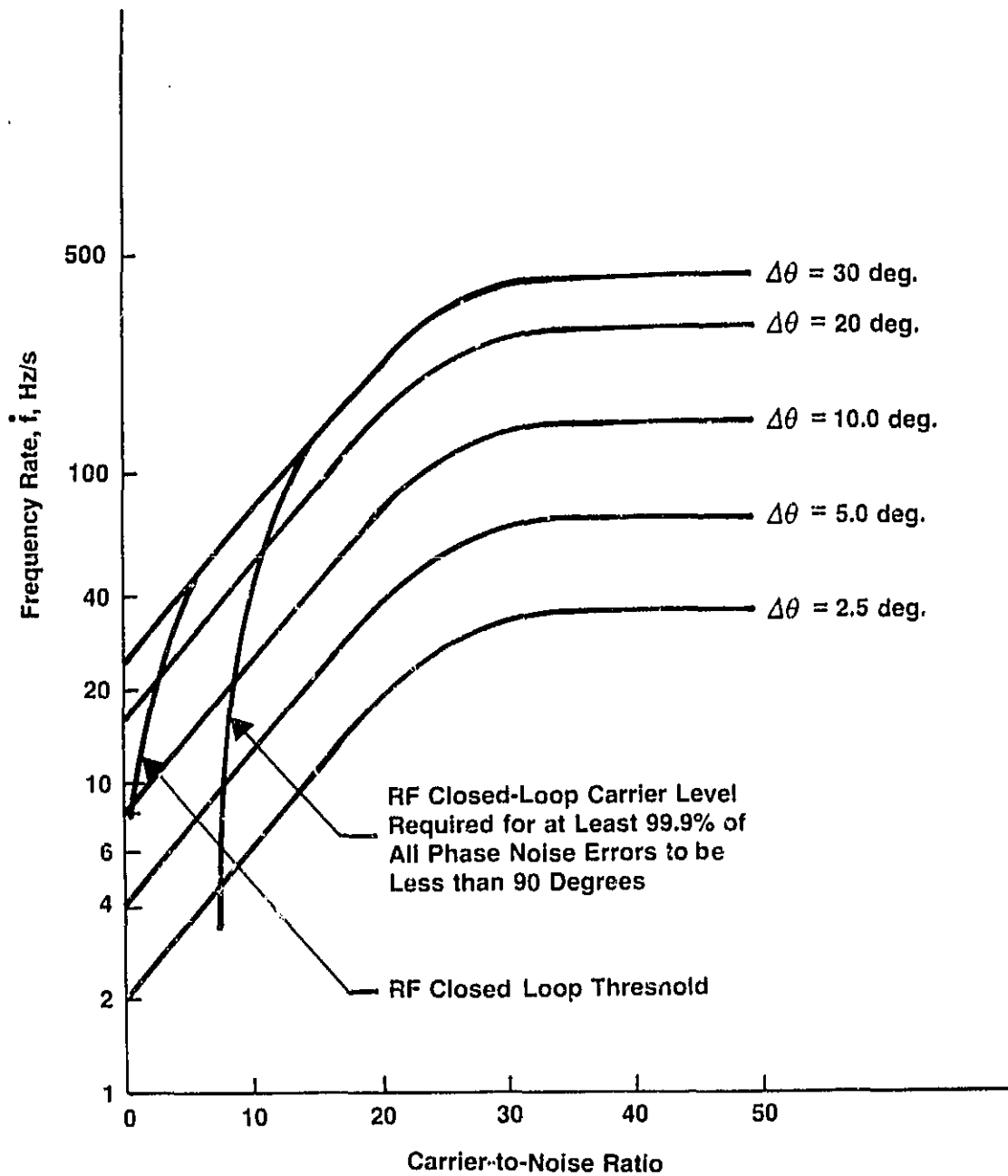

Figure 7. Typical Frequency Rate Capability; $2B_{L0} = 18$ Hz

From section 3, the carrier-to-noise density at the input to the limiter will be 0.25 dB (1.06) greater than the output value. Consequently, the input carrier-to-noise density, c/η_i , is given by,

$$\frac{c}{\eta_i} = 1.06 \cdot 2 B_{LO} \rho_o, \text{ Hz}^{-1} \quad (22)$$

The limiter input carrier-to-noise ratio is given by,

$$\rho_i = \frac{1.06 \cdot 2 B_{LO} \rho_o}{\frac{\pi}{2} B_s} \quad (23)$$

where the factor $\pi/2$ accounts for the difference between the 3 dB bandwidth and the noise bandwidth of a single-pole bandpass filter.

Evaluating equation (23) and substituting the result into equation (14) yields 0.0563 for α_o (implies that the limiter input carrier-to-noise ratio is -25dB).

The curves presented in Figure 7 were developed using equation (20). Also included in Figure 7 are the RF closed-loop threshold curve and the curve showing the carrier-to-noise ratio in the loop required to maintain the phase noise error less than 90 degrees with 0.999 probability. These latter curves were obtained from Figure 6. Numerical values for the points are given in Table 1.

The following conclusions may be drawn from Figure 7. For a carrier-to-noise ratio greater than 7.4 dB in the design loop noise bandwidth ($2 B_{LO}$) a composite sweep rate (the sum of the transmitted sweep rate and

TABLE 1

THRESHOLD CARRIER-TO-NOISE RATIO (CNR_T) AND
CARRIER-TO-NOISE RATIO REQUIRED TO MAINTAIN PHASE NOISE ERRORS
TO LESS THAN 90 DEGREES WITH PROBABILITY 99.9% ($CNR_{99.9}$)

(deg)	$CNR_{99.9}$ (dB)	CNR_T (dB)
2.5	7.4	0
5.0	7.4	0
10	8.7	0.6
20	11.0	3.0
30	14.2	6.1

the uncorrected doppler rate) of 4.7 Hz/sec or less will result in acquisition with a probability greater than 0.90. After the loop acquires lock, and the transients decay, the mean steady-state phase error will be 2.5 degrees.

Similarly, if the carrier-to-noise ratio is greater than 14.2 dB, a composite sweep rate of 125 Hz/sec or less will result in an acquisition probability greater than 0.90; and, in the steady-state the mean phase error will be 30 degrees.

5.2 EARTH STATION RECEIVER SWEEP RATE

Using the procedure given in Section 5.1, similar curves may be derived for the Earth station receiver sweep rate as shown in Figures 8 and 9.

The minimum composite sweep rate may be obtained from Figure 8 for a 1 Hz bandwidth and a 2.5 degree mean steady-state phase error. The curve indicates a composite sweep rate of about 0.015 Hz/sec.

The maximum composite sweep rate may be obtained from Figure 9 for a 300 Hz bandwidth and a 30 degree mean steady-state error. A composite sweep rate of about 35 kHz/sec is indicated.

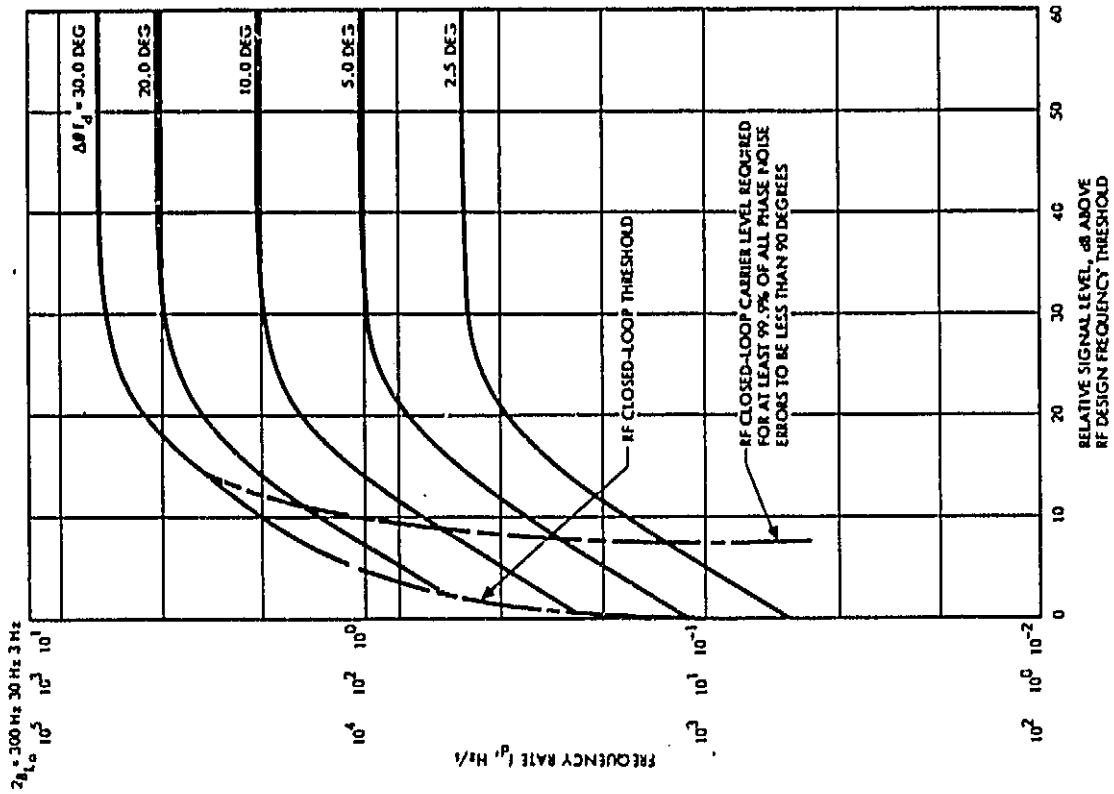

Figure 9. Typical Frequency Rate Capability; $28_{L_0} = 3, 30, 300 \text{ Hz}$

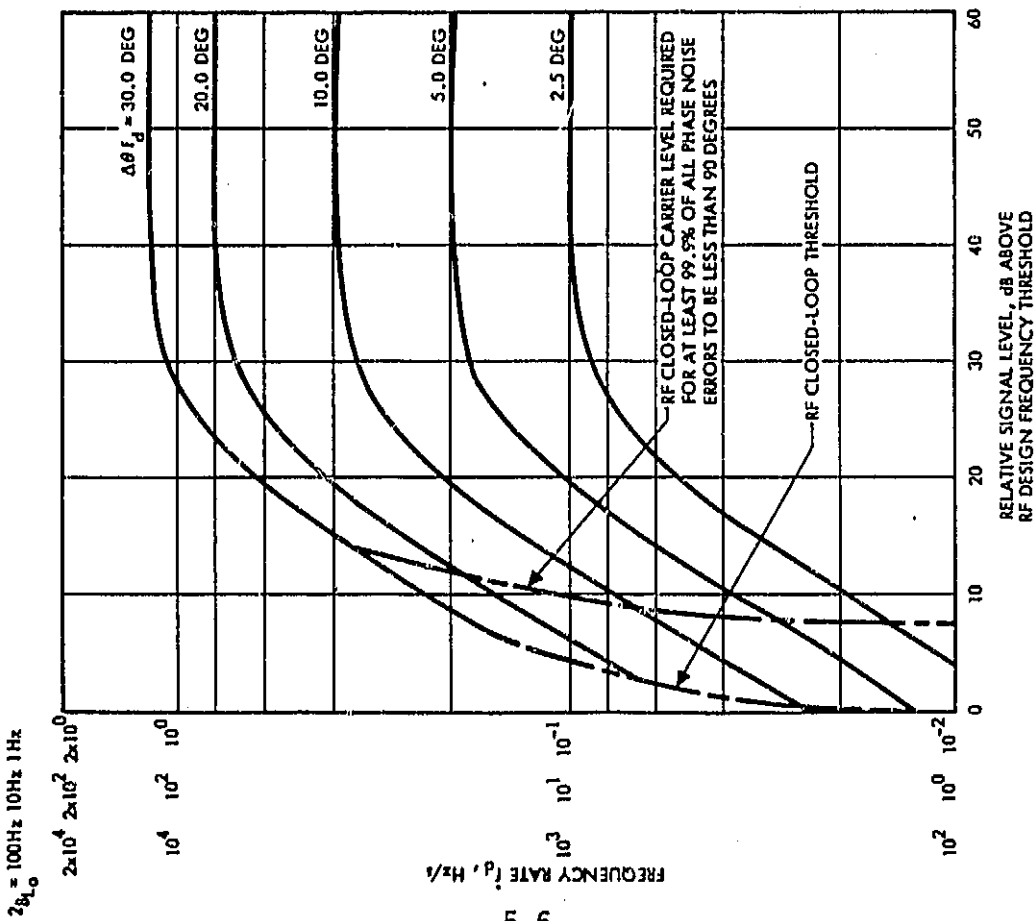

Figure 8. Typical Frequency Rate Capability; $28_{L_0} = 1, 10, 100 \text{ Hz}$

BIBLIOGRAPHY

"Deep Space Network/Flight Project Interface Design Handbook, Volume II: Proposed DSN Capabilities", Document 810-5, Rev. D, Volume II, JPL, February 1984.

"Tracking Operations Analysis", A.L. Berman, (internal JPL document), 1976.

"DSN Network Operating Procedures", Doc. 618-700; Rev. F, Section V (internal JPL document).

"Deep Space Telecommunications Systems Engineering", Edited by J.H. Yuen, JPL Publication 82-76, July 1982.

W.C. Lindsey and M.K. Simon, "Telecommunication Systems Engineering", Prentice-Hall, Inc., 1973.

J.K. Holmes, "Coherent Spread Spectrum Systems", John Wiley and Sons, 1982.

F.M. Gardner, "Phaselock Techniques", Second Edition, John Wiley and Sons, 1979.