

## General Disclaimer

### One or more of the Following Statements may affect this Document

- This document has been reproduced from the best copy furnished by the organizational source. It is being released in the interest of making available as much information as possible.
- This document may contain data, which exceeds the sheet parameters. It was furnished in this condition by the organizational source and is the best copy available.
- This document may contain tone-on-tone or color graphs, charts and/or pictures, which have been reproduced in black and white.
- This document is paginated as submitted by the original source.
- Portions of this document are not fully legible due to the historical nature of some of the material. However, it is the best reproduction available from the original submission.

DOE/NASA/12726-25  
NASA TM-87034

# Cycling Performance of the Iron-Chromium Redox Energy Storage System

(NASA-TM-87034) CYCLING PERFORMANCE OF THE  
IRON-CHROMIUM REDOX ENERGY STORAGE SYSTEM  
(NASA) 19 p HC A02/MF A01 CSCL 10C

N85-27387

Unclas  
G3/44 21335

Randall F. Gahn, Norman H. Hagedorn,  
and Jerome A. Johnson  
National Aeronautics and Space Administration,  
Lewis Research Center



Work performed for  
**U.S. DEPARTMENT OF ENERGY**  
**Conservation and Renewable Energy**  
**Division of Energy Storage Systems**

Prepared for  
Twentieth Intersociety Energy Conversion Engineering Conference  
cosponsored by the SAE, ANS, ASME, IEEE, AIAA, ACS, and AIChE  
Miami Beach, Florida, August 18-23, 1985

# **Cycling Performance of the Iron- Chromium Redox Energy Storage System**

Randall F. Gahn, Norman H. Hagedorn,  
and Jerome A. Johnson  
National Aeronautics and Space Administration  
Lewis Research Center  
Cleveland, Ohio 44135

Work performed for  
U.S. DEPARTMENT OF ENERGY  
Conservation and Renewable Energy  
Division of Energy Storage Systems  
Washington, D.C. 20545  
Under Interagency Agreement DE-AI04-80AL12726

Prepared for  
Twentieth Intersociety Energy Conversion Engineering Conference  
cosponsored by the SAE, ANS, ASME, IEEE, AIAA, ACS, and AIChE  
Miami Beach, Florida, August 18-23, 1985

# CYCLING PERFORMANCE OF THE IRON-CHROMIUM REDOX ENERGY STORAGE SYSTEM

Randall F. Gahn, Norman H. Hagedorn, and Jerome A. Johnson  
National Aeronautics and Space Administration  
Lewis Research Center  
Cleveland, Ohio 44135

## SUMMARY

Extended charge-discharge cycling of this electrochemical storage system at 65 °C was performed on 14.5 cm<sup>2</sup> single cells and a four cell, 867 cm<sup>2</sup>, bipolar stack. Both the anolyte and catholyte reactant fluids contained 1 molar concentrations of iron and chromium chlorides in hydrochloric acid and were separated by a low-selectivity, cation-exchange membrane. The effect of cycling on the chromium electrode and the membrane was determined. Bismuth and bismuth-lead catalyzed chromium electrodes and a radiation-grafted polyethylene membrane were evaluated by cycling between 5 and 85 percent state-of-charge at 80 mA/cm<sup>2</sup> and by periodic charge-discharge polarization measurements to 140 mA/cm<sup>2</sup>. Gradual performance losses were observed during cycling but were recoverable by completely discharging the system. Good scale-up to the 867 cm<sup>2</sup> stack was achieved. The only difference appeared to be an unexplained resistive-type loss which resulted in a 75 percent W-hr efficiency (at 80 mA/cm<sup>2</sup>) versus 81 percent for the 14.5 cm<sup>2</sup> cell. A new rebalance cell was developed to maintain reactant ionic balance. The cell successfully reduced ferric ions in the iron reactant stream to ferrous ions while chloride ions were oxidized to chlorine gas.

## INTRODUCTION

The iron-chromium redox energy storage system is being considered as a method for electric utility load-leveling and for electrical energy storage for photovoltaic and wind turbine sources (ref. 1). Significant advances in the technology since 1981 indicate this electrochemical energy storage technique to be a technically sound concept (ref. 2). System components consist of mixed iron and chromium reactant solutions (ferrous/ferric and chromous/chromic solutions) which are stored in external tanks, a power conversion unit through which the reactants are continuously circulated, a low-selectivity semi-permeable cation-exchange membrane to separate the flowing reactants, and carbon felt electrodes catalyzed with a trace quantity of bismuth or bismuth-lead combination (ref. 3). Electrical energy is either supplied to the power conversion unit to charge the reactants or removed as the charged reactants electrochemically discharge.

The use of mixed reactants eliminates the requirement for a highly selective membrane since the composition of both reactant streams is identical in the discharged state. The increased cross-mixing of charged species simply results in a slightly reduced coulombic efficiency. Mixing of the iron and chromium reactants also results in a lower open-circuit voltage than separate reactants due to thermodynamic effects. The consequence of accepting both the lower coulombic efficiency and the reduced open-circuit voltage is offset by a greater improvement in the voltage efficiency which results in an overall improvement in the watt-hour efficiency. Two inherent problems of flowing electrolyte systems, i.e., reactant cross-mixing and osmotic solvent transfer

can readily be resolved by remixing and repartitioning the reactants in the discharged state.

System operation at 65 °C has improved the electrode kinetics of the chromous/chromic redox reaction, reduced membrane resistivity and will also be beneficial in the operation of large storage systems since heat rejection will be easier to handle. Previous development work (ref. 3) on lab-size cells has shown that the Redox concept, employing mixed reactants, elevated temperatures operation, a low-selectivity membrane, and a soluble catalyst, met current density and efficiency requirements for consideration in larger applications.

The purpose of the present work was to test the iron-chromium system over extended cycling periods to determine if changes in performance occur which are related to the electrodes or the membrane. Lab-size, 14.5 cm<sup>2</sup> single cells and a four cell, 867 cm<sup>2</sup> stack were evaluated by cycling between approximately 5 and 85 percent state-of-charge. Polarization tests, resistivity measurements, and full cycle watt-hour efficiencies were used to evaluate electrode and membrane performance.

Electrochemical balance of the Redox reactants is necessary in order to maintain the system's effective coulombic capacity. Hydrogen evolution at the chromium electrode during charging and the intrusion of oxygen into the system cause the iron reactant to become more highly charged than the chromium reactant. The previous technique for rebalancing the iron-chromium system employed an iron-hydrogen electrochemical cell. The iron reactant sidestream was circulated through the rebalance cell where the ferric ion was reduced to ferrous ion while hydrogen gas, generated from the chromium charging reaction or from an external source, was oxidized to hydrogen ions. This rebalancing technique, however, had two disadvantages; (a) the performance decreased with time due to flooding of the hydrogen electrode, and (b) the platinum catalyzed hydrogen electrode caused contamination of the chromium electrode because of the solubility of platinum in the hydrochloric acid system under oxidative conditions.

A new approach to rebalancing the reactants was devised and evaluated as a part of this work. Ferric ions are reduced to ferrous ions in one side of a typical cell, while chloride ions are oxidized to chlorine gas in the other half of the cell. Although this technique requires energy (versus the iron-hydrogen reaction which produces energy), its performance characteristics and its effect on the iron-chromium cell performance were studied.

Electrode catalyst stability and membrane resistance variations were evaluated on 14.5 cm<sup>2</sup> single-cell systems, which were cycled automatically between pre-set voltage limits. Periodic cycling of the four-cell stack over a 6 month period was also used to measure electrode and membrane performance and monitor energy efficiency. Both systems incorporated an iron-chlorine rebalance cell.

## EXPERIMENTAL MEASUREMENTS

A schematic diagram of the typical system used for the cycling studies is shown in figure 1. The system includes the iron-chromium power conversion cell, an iron-chlorine rebalance cell, reactant reservoirs, and magnetically driven circulating pumps. Both the iron and chromium reactant solutions were

1 molar in total iron concentration, 1 molar in total chromium ion concentration, and 3 molar in hydrochloric acid. The reactant for the chlorine side of the rebalance cell was  $1 \text{ MFe}^{3+}/1 \text{ MCr}^{3+}/3 \text{ NHCl}$ . The bismuth or bismuth-lead catalyst was added to all reactant solutions and then electrochemically deposited onto the chromium electrode. The iron-chromium system tubing was polyethylene and the iron-chlorine system tubing was a fluorocarbon plastic. Immersion heaters were installed in the reactant reservoirs for the four-cell stack system. Tube heaters were used on the cell inlet lines for the  $14.5 \text{ cm}^2$  cell system. Reactant temperatures were measured at the cell inlet and outlet on the stack and in the reactant reservoirs on the  $14.5 \text{ cm}^2$  cell systems. Temperature control on the systems was generally within  $\pm 2 \text{ }^\circ\text{C}$ . The normal operating temperature was  $65 \text{ }^\circ\text{C}$ , although tests were also conducted on the stack at lower temperatures.

Voltage, current, and current-time measurements were recorded from the iron-chromium and iron-chlorine cells. The volume of hydrogen generated at the chromium electrode was measured by water displacement, and the hydrogen was then vented. Chlorine generated in the rebalance cell was flushed from the system with nitrogen gas and then reacted with a potassium hydroxide solution. Hydrogen and chlorine were replenished in the system through periodic additions of concentrated hydrochloric acid. For a completely closed system the hydrogen and chlorine gases could be recombined either catalytically using ultraviolet light or electrochemically.

Cell charge and discharge polarization measurements at given states-of-charge were made by applying short term (1 min or less) current steps of from 10 to  $140 \text{ mA/cm}^2$  and measuring the cell voltage when it became apparently stable. Cell resistance was measured with a 1 kHz ac impedance bridge and compared with the slopes of the charge and discharge polarization curves. Because of the well-behaved character of the iron electrode, any deviations from the ac measurement were attributed to changing reaction kinetics at the chromium electrode.

Watt-hour measurements for both the single cells and the stack were made by integrating voltage-time curves from constant current charge-discharge cycles made between selected states-of-charge. The iron-chlorine rebalance cell was operated with a dc power supply using manual control. Generally, a continuous rebalancing process at a low current density (1 to  $2 \text{ mA/cm}^2$ ) was sufficient to maintain reactant balance; however, current densities as high as  $20 \text{ mA/cm}^2$  have been used for batch rebalancing. Nitrogen purging of the chlorine reactant stream was necessary to remove the chlorine and prevent cavitation in the centrifugal pump.

## RESULTS AND DISCUSSION

The results presented below were obtained from the charge-discharge cycling of two labsize single-cell systems and one four-cell stack containing three working cells and one open-circuit cell. The iron-chlorine rebalance cell was used with all three systems to maintain reactant balance. One 3 A-hr, lab-size system was catalyzed with bismuth and cycled 603 times over a period of 14 weeks. The second lab-size system with 4 A-hr capacity was catalyzed with a bismuth-lead combination and completed 186 cycles over a period of 7 weeks. The four-cell stack system contained 134 A-hr of capacity and was

catalyzed with bismuth. This system was cycled intermittently over a period of 7 months.

### Electrode Performance

Bismuth-only and bismuth-lead catalysts were evaluated under extended cycling conditions. Bismuth concentrations on the carbon felt substrate were varied from 33 to 165  $\mu\text{g}/\text{cm}^2$ . The single bismuth-lead combination studied was 110  $\mu\text{g Bi}/\text{cm}^2$  and 90  $\mu\text{g Pb}/\text{cm}^2$ .

Previous catalyst studies (ref. 3) focused primarily on the bismuth system because of an unexplained anomaly which occurs at a high state-of-charge with the bismuth-lead system. The typical anomaly, shown in figure 2, occurred above 90 percent state-of-charge of the chromium reactant. The undesirable aspect of the anomaly was that the electrode performance became irreversible, primarily on charge, after it went through the anomaly. The performance remained irreversible until the chromium electrode was completely discharged which allowed the catalyst to be stripped (oxidized) from the carbon felt substrate. Replating the catalyst restored reversible performance as long as the chromium electrode did not exceed 90 percent state-of-charge. Higher lead catalyst loadings shifted the anomaly to an even higher state-of-charge. The anomaly with the 110  $\mu\text{g}/\text{cm}^2$  bismuth and 90  $\mu\text{g}/\text{cm}^2$  lead loading occurs at about 95 percent state-of-charge. Since practical system operation is below this value, this unexplained anomaly is expected to have no detrimental effect on the electrode performance. No similar charging anomaly was observed with freshly replated bismuth-only catalyzed systems. However, bismuth loadings below 55  $\mu\text{g}/\text{cm}^2$  were not always reversible. Bismuth catalyst loadings above 55  $\mu\text{g}/\text{cm}^2$  always gave reversible performance during studies in which the catalyst was stripped at the end of each cycle and replated for the next cycle. Continuous cycling results of a system catalyzed with 55  $\mu\text{g Bi}/\text{cm}^2$  are shown in figure 3. When charging was begun before the chromium was completely discharged, the cell performance gradually became irreversible, especially on charge. The major difference in the discharge slope is due to an increase in the membrane resistance, however, the nonlinearity of the discharge polarization curve indicates some kinetic polarization losses.

The bismuth catalyzed system was also evaluated at electrode loadings of 110 and 165  $\mu\text{g}/\text{cm}^2$ . Figure 4 shows polarization curves for a system catalyzed at 165  $\mu\text{g Bi}/\text{cm}^2$  after cycling between 5 and 85 percent state-of-charge for 69 cycles without stripping the bismuth from the chromium electrode. The ac impedance measurement after 69 cycles is shown for comparison. The system was then reconditioned by discharging the reactants, stripping the bismuth, and remixing the reactants. The slopes of the cell polarization curves for the reconditioned system were in good agreement with the ac impedance measurements. The overall cell performance also returned to the initial performance because the membrane resistance decreased during reconditioning. Again, polarization losses were greater on charge than on discharge after 69 cycles, but both were essentially reversible following reconditioning.

As a result of the gradual performance loss with cycle on the bismuth catalyzed system, additional cycling of the bismuth-lead catalyzed system was warranted, in spite of the charging anomaly. Figure 5 shows polarization



results, initially and after 93 cycles without catalyst stripping, for a system containing  $110 \mu\text{g Bi/cm}^2$  and  $90 \mu\text{g Pb/cm}^2$ . The ac impedance measurement after 93 cycles is shown as a dashed line for the charge portion of the polarization curve. After 93 cycles the cell discharge appeared to be reversible, i.e., the slope of the cell polarization curve is in agreement with the ac impedance measurement. The change in performance can therefore, be entirely attributed to the increase in membrane resistance. The charge polarizations showed slight deviations from reversible behavior, but they were significantly less than those for the bismuth catalyzed system.

The rate of loss of electrode performance as a function of cycle number is given in figure 6. The difference between the slopes of the charge and discharge polarization curves is plotted for a period of cycling in which the catalysts were not stripped. The bismuth-lead system with loadings of  $110 \mu\text{g Bi/cm}^2$  and  $90 \mu\text{g Pb/cm}^2$  is compared with a bismuth system with a  $110 \mu\text{g Bi/cm}^2$  loading. The rate of change of the bismuth system is significantly greater than that of the bismuth-lead system indicating a more rapid loss of kinetic activity for the bismuth catalyst.

#### Membrane Performance

The ML-21<sup>1</sup> membrane was used for all of the  $14.5 \text{ cm}^2$  single cells and in the four-cell stack. Cell resistivity measurements using the impedance bridge were monitored during cycling of a bismuth-lead catalyzed system. This system was chosen because of its nearly reversible electrode behavior on discharge, so that any resistance changes are membrane related. Results are shown in figure 7 and indicate a resistance increase with cycle. The resistance increase is gradual and after 93 cycles does not appear to have stabilized. Although this represents about a 33 percent resistance increase, watt-hour efficiency for the system would be about 80 percent at  $80 \text{ mA/cm}^2$ . After the cell resistivity had reached  $0.91 \Omega\text{-cm}^2$  (membrane resistivity is about  $0.61 \Omega\text{-cm}^2$ ) the system was discharged completely and the reactants remixed.

During the reconditioning process the membrane is exposed to completely discharged reactants ( $\text{Fe}^{+2}$  and  $\text{Cr}^{+3}$ ). Previous membrane studies (ref. 4) have shown that other semi-permeable membranes are subject to fouling by ferric "chloro" complexes causing an increase in resistance. Removing these species from the membrane restores its original resistance and cell performance. Since both the electrode and membrane begin to deviate from their initial performance after 100 cycles, reconditioning of the system at this point would maintain acceptable cell performance. Longer-term cycling effects were observed with the bismuth catalyzed system. Periodic measurements of cycle watt-hour efficiencies presented in table I show some variation as a result of changes in membrane resistance, but they demonstrate that an 80 percent efficiency can be maintained during extended cycling. Ampere-hour efficiency, chromium reactant state-of-charge range, and hydrogen evolution for the  $80 \text{ mA/cm}^2$  cycles are also given.

---

<sup>1</sup>Source RAI Research Corporation, Hauppauge, L.I., NY 11788.



## Stack Performance

The primary objective of the stack performance studies was to verify scale-up from the lab-size cells. Catalyst plating was found to be a critical step in the preparation of a reversible chromium electrode. The standard flash-plating technique used for the 14.5cm<sup>2</sup> cells and a low-current plating procedure were studied. During flash plating the stack was first deep discharged for about 5 percent of its coulombic capacity to a negative open-circuit voltage. The stack was then charged at the cycling current density (generally 60 or 80 mA/cm<sup>2</sup>) from a negative open-circuit voltage, passing through zero and continuing at the same current into the cycle. During low-current plating the stack was again discharged to a slightly negative open-circuit voltage. The stack was then charged at 5 mA/cm<sup>2</sup> until the system was 5 percent charged. Charging current was then increased to the cycling value.

Charge and discharge polarization tests to 80 mA/cm<sup>2</sup> shown in figure 8 were used to evaluate the two plating techniques. Comparison of the two at 50 percent state-of-charge and 52 °C shows the charge irreversibility of the low-current plating. Flash plating at 52 and 60 °C yielded reversible charge and discharge performance. The flash-plating procedure for catalyst deposition has been shown to be a reliable and simple method for the preparation of reversible chromium electrodes.

Watt-hour efficiencies at 60 and 80 mA/cm<sup>2</sup> were measured for the center cell of the stack. The center cell has a bipolar configuration which is representative of the interior cells of larger stacks. This cell also has a lower resistance than the end cells since resistive losses through a thin bipolar carbon plate are less than those through the thicker carbon current-collector plates with edge current collection. Maximum performance should be obtained from the center cell.

Figure 9 shows a typical constant current charge and discharge between 15 and 85 percent state-of-charge for the center cell of the stack. Watt-hour efficiencies for the center cell and the stack are also given. The center cell efficiencies at 60 and 80 mA/cm<sup>2</sup> are 76 and 75 percent, respectively. Efficiencies for the stack at the same current densities are 74 and 73 percent, respectively. Comparison of watt-hour efficiencies of the stack center cell and the 14.5 cm<sup>2</sup> lab-size cell shows a difference of about 6 percent. A reason for this apparent loss of performance scale-up is not known. Some difference in performance is expected between a single cell and an individual cell from a bipolar stack because of shunt currents in the stack. However, losses from a three-cell stack would not account for this difference.

Figure 10 gives polarization test results after 6 months of testing for the stack center cell at 20, 40, 60, and 80 percent state-of-charge. Up to 60 percent state-of-charge the performance is essentially reversible, however, at 80 percent state-of-charge the charge performance began to deviate significantly at 60 mA/cm<sup>2</sup> and above. Discharge polarizations had a slight voltage shift around 80 mA/cm<sup>2</sup>. A possible explanation for the change in electrode behavior is that some iron may be reduced on the electrode at the higher voltages, especially if flow distribution is poor through the felt. This has been observed in 14.5 cm<sup>2</sup> cell systems. The system must then be reconditioned to restore reversible performance. Performance at all states-of-charge were consistent throughout the 6 months testing period.

## Rebalance Cell

The iron-chlorine rebalance cell has demonstrated excellent performance over a period of 1 yr in both the 14.5 and 310 cm<sup>2</sup> sizes. There have been no noticeable detrimental effects of the rebalance cell on the performance of the iron-chromium system. Generally, the rebalance cell is operated continuously at 1 to 2 mA/cm<sup>2</sup> in order to maintain reactant balance when the iron-chromium cell is operating at 80 mA/cm<sup>2</sup>. Chlorine is liberated at the anode as ferrous ions are produced at the cathode. Since this reaction is not spontaneous energy was supplied. A polarization curve for the cell is shown in figure 11 for current densities to 10 mA/cm<sup>2</sup>. Cell performance is not reversible, which can be attributed to the chlorine electrode. At low current densities the energy required to maintain balance is about 1 percent of the charge or discharge energy of the iron-chromium cell, but since rebalancing is continuous the overall energy penalty is about 2 percent. More efficient chlorine electrode materials are available, but the use of carbon felt avoids any possibility of system contamination. During rebalancing the potential of the iron-chlorine cell can be monitored to give an indication of the state-of-charge of the iron reactant. Cell voltage must be calibrated for a given current density since the chlorine electrode is not reversible.

## CONCLUDING REMARKS

Extended cycling of the iron-chromium Redox system between 5 and 85 percent state-of-charge showed a decrease in cell performance with cycling which was attributable to both the electrodes and the membrane. Apparent changes in the catalyst caused gradual electrode polarization losses primarily on charge. A gradual resistance increase of the cationexchange membrane also caused a decrease in cell performance. In all cases, however, initial performance could be restored by completely discharging the system. Bismuth-lead catalyzed systems appeared to have more stable performance than the bismuth catalyzed system. About 100 cycles could be achieved with watt-hour efficiencies greater than 80 percent at 80 mA/cm<sup>2</sup> current density before reconditioning was necessary.

Scale-up from the 14.5 cm<sup>2</sup> cells to the 867 cm<sup>2</sup> cells verified the catalyst plating procedure and generally gave reversible electrode performance. The watt-hour efficiency loss of about 6 percent observed on the scale-up indicates either an unaccounted resistive or polarization loss.

Extended operation of the iron-chlorine rebalance cell has demonstrated its capability to satisfactorily maintain electrochemical balance of the iron and chromium reactants. Good control of the rebalancing operation was achieved without any evidence of interference in the functioning of the iron-chromium cell. Since this cell requires energy, the overall efficiency of the Redox system is reduced by about 2 percent.

Excellent performance was achieved during extended cycling of the Redox energy storage system. Results on both 14.5 and 867 cm<sup>2</sup> cells confirm the system's flexibility and the advantages of this well-defined approach to energy storage.

## REFERENCES

1. N.H. Hagedorn, and L.H. Thaller, "Design Flexibility of Redox Flow Systems." IECEC '82; Proceedings of the Seventeenth Intersociety Energy Conversion Engineering Conference, Vol.2, IEEE, 1982, pp. 600-609.
2. N.H. Hagedorn, "NASA Redox Storage System Development Project." NASA TM-83677, 1984.
3. R.F. Gahn, N.H. Hagedorn, and J.S. Ling, "Single Cell Performance Studies on the Fe/Cr Redox Energy Storage System Using Mixed Reactant Solutions at Elevated Temperature." IECEC '83; Proceedings of the Eighteenth Intersociety Energy Conversion Engineering Conference, Vol. 4, AIChE, 1983, pp. 1647-1652.
4. J.S. Ling, and J. Charleston, "Advances in Membrane Technology for the NASA Redox Energy Storage System." NASA TM-82701, 1980.

Table I. - Performance of Bismuth Catalyzed System  
at 80 mA/cm<sup>2</sup>

(a)

Cycle number	Watt-hour efficiency, percent	Cell resistivity, $\Omega$ -cm <sup>2</sup>	Ampere-hour efficiency, percent	Cycles after reconditioning
266	80.1	1.20	94.0	22
477	76.7	1.25	91.3	4
506	81.1	1.20	92.3	4

(b)

Cycle number	Bi loading, $\mu$ g/cm <sup>2</sup>	H <sub>2</sub> evolution, percent of charge ampere-hours	Cr S.O.C. range, percent
266	110	0.69	5 to 87
477	110	.86	5 to 93
506	165	1.4	5 to 85

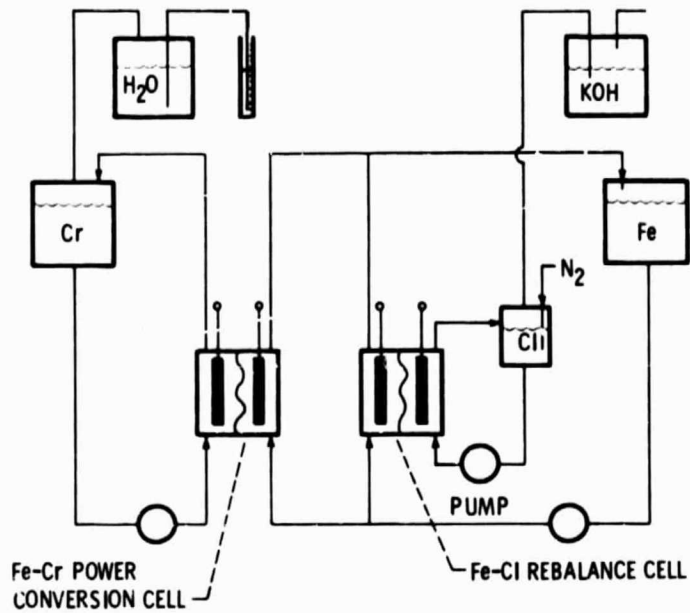

Figure 1. - Typical Redox system used for cycling studies.

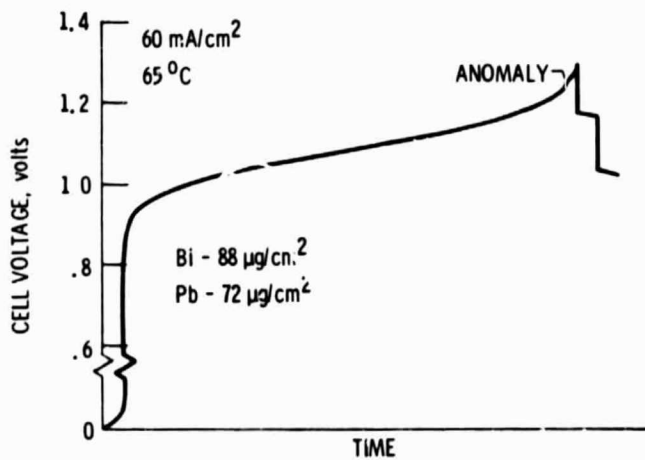

Figure 2. - Charging anomaly with bismuth-lead catalyzed system.

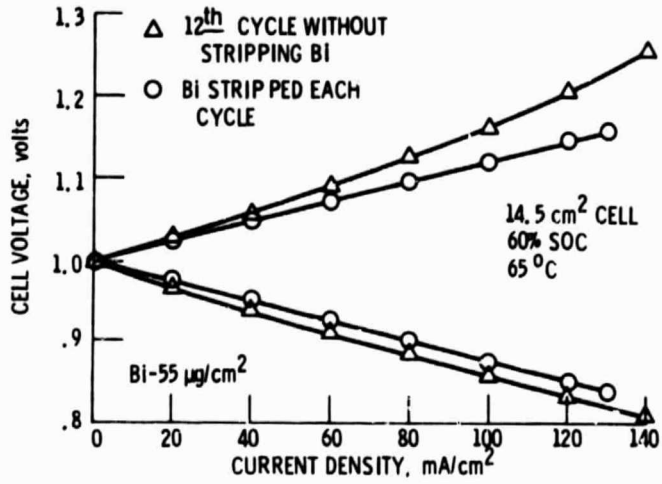

Figure 3. - Effect of cycling with continuous catalyst stripping.

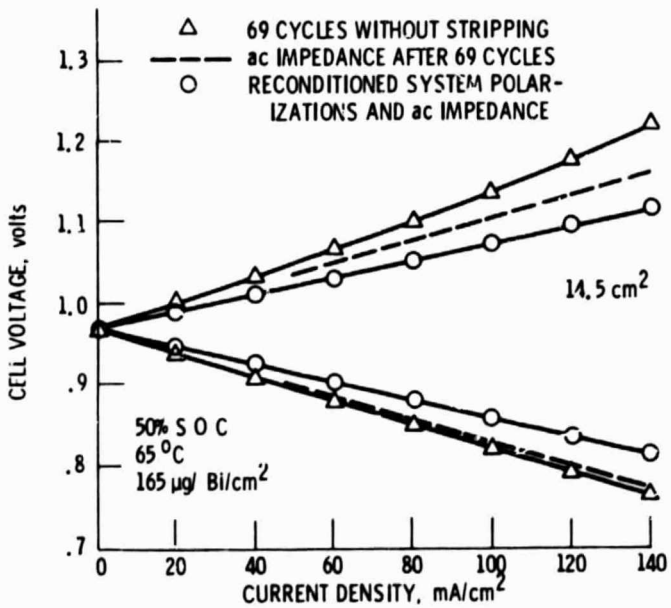

Figure 4. - Performance of bismuth catalyzed system.



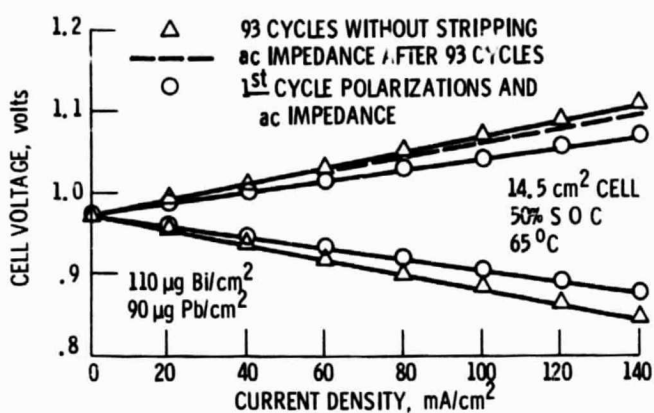

Figure 5. - Performance of mismatch-lead catalyzed system.

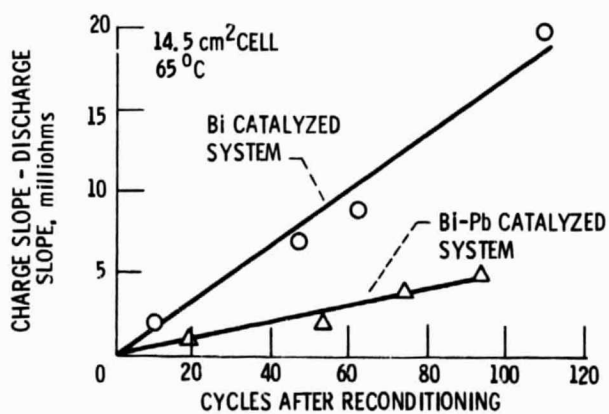

Figure 6. - Loss in polarization performance with cycle.

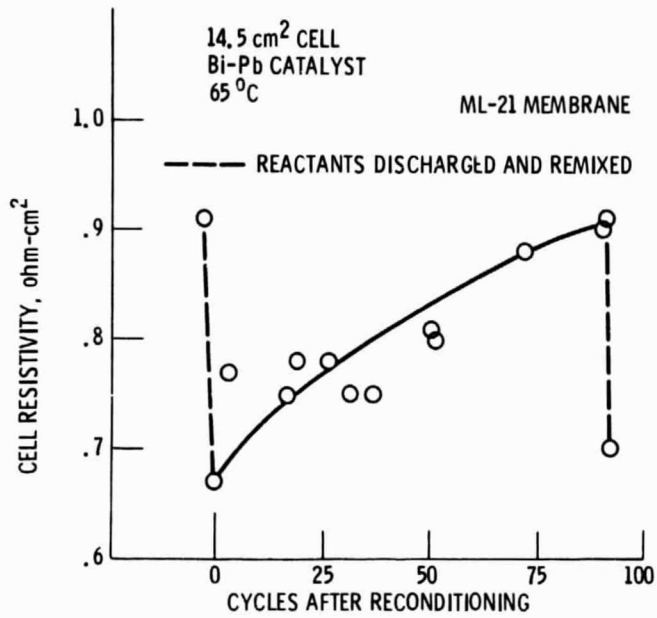

Figure 7. - Changes in the Fe-Cr cell resistivity related to the membrane.

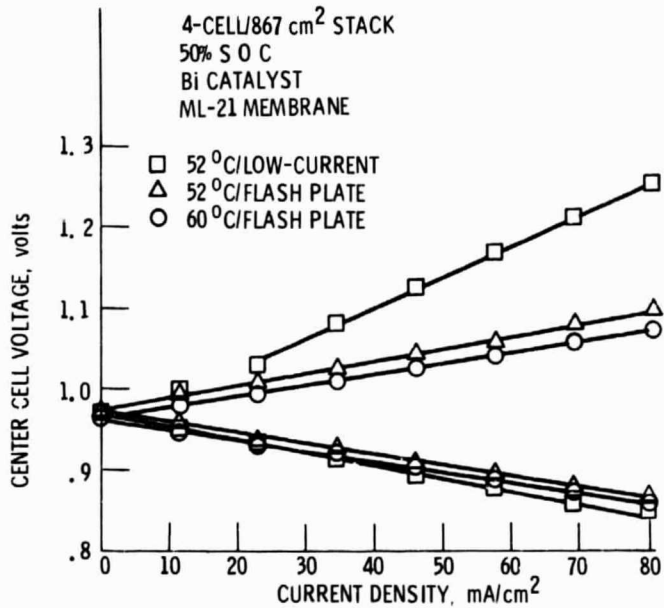

Figure 8. - Comparison of catalyst plating techniques.

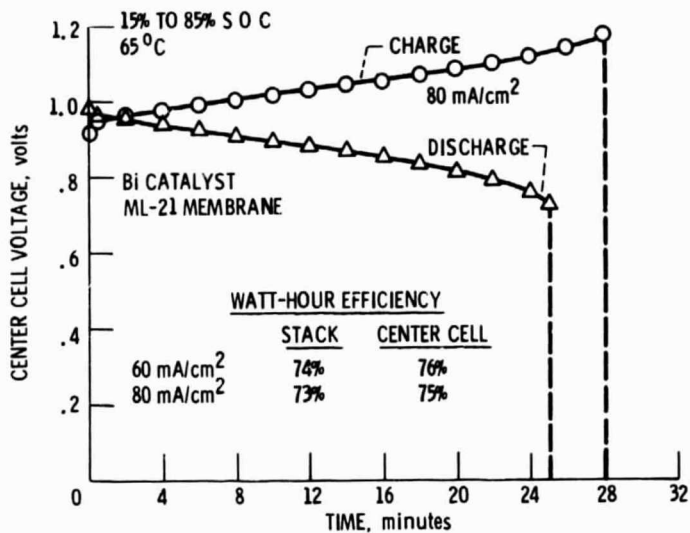

Figure 9, - Constant current performance of the 4-cell, 867 cm<sup>2</sup> stack.

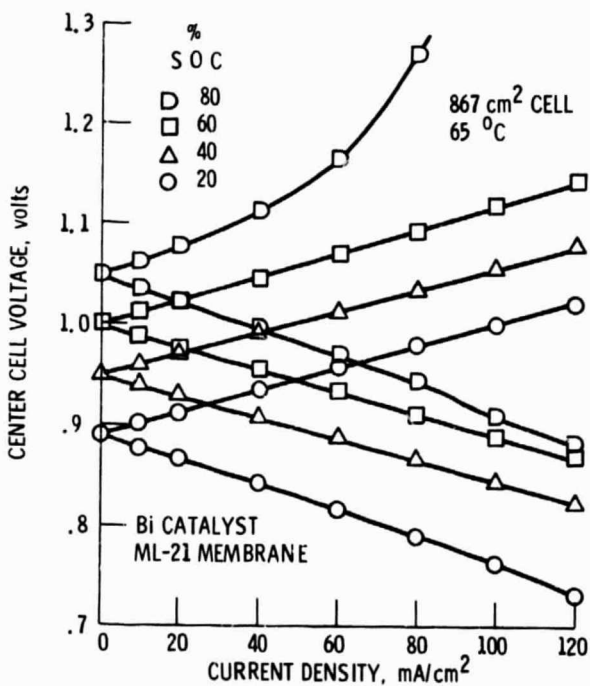

Figure 10, - Polarization performance of the 4-cell stack after six months of testing.

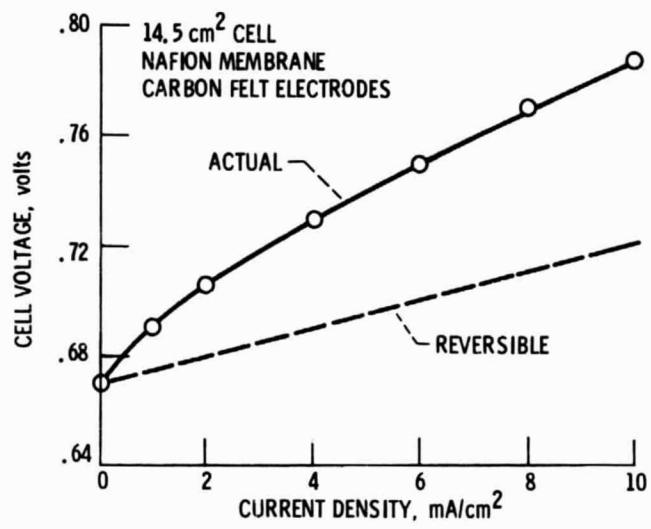

Figure 11. - Iron-Chlorine recharge cell polarization performance.

1. Report No. NASA TM-87034		2. Government Accession No.		3. Recipient's Catalog No.	
4. Title and Subtitle  Cycling Performance of the Iron-Chromium Redox Energy Storage System				5. Report Date	
				6. Performing Organization Code 141-20-17	
7. Author(s)  Randall F. Gahn, Norman H. Hagedorn, and Jerome A. Johnson				8. Performing Organization Report No. E-2590	
				10. Work Unit No.	
9. Performing Organization Name and Address  National Aeronautics and Space Administration Lewis Research Center Cleveland, Ohio 44135				11. Contract or Grant No.	
				13. Type of Report and Period Covered Technical Memorandum	
12. Sponsoring Agency Name and Address  U.S. Department of Energy Division of Energy Storage Systems Washington, D.C. 20545				14. Sponsoring Agency Code Report No. DOE/NASA/12726-25	
				15. Supplementary Notes  Prepared under Interagency Agreement DE-A104-80AL12726. Prepared for Twentieth Intersociety Energy Conversion Engineering Conference cosponsored by the SAE, ANS, ASME, IEEE, AIAA, ACS, and AIChE, Miami Beach, Florida, August 18-23, 1985.	
16. Abstract  Extended charge-discharge cycling of this electrochemical storage system at 65 °C was performed on 14.5 cm <sup>2</sup> single cells and a four cell, 867 cm <sup>2</sup> , bipolar stack. Both the anolyte and catholyte reactant fluids contained 1 molar concentrations of iron and chromium chlorides in hydrochloric acid and were separated by a low-selectivity, cation-exchange membrane. The effect of cycling on the chromium electrode and the cation-exchange membrane was determined. Bismuth and bismuth-lead catalyzed chromium electrodes and a radiation-grafted polyethylene membrane were evaluated by cycling between 5 and 85 percent state-of-charge at 80 mA/cm <sup>2</sup> and by periodic charge-discharge polarization measurements to 140 mA/cm <sup>2</sup> . Gradual performance losses were observed during cycling but were recoverable by completely discharging the system. Good scale-up to the 867 cm <sup>2</sup> stack was achieved. The only difference appeared to be an unexplained resistive-type loss which resulted in a 75 percent W-hr efficiency (at 80 mA/cm <sup>2</sup> ) versus 81 percent for the 14.5 cm <sup>2</sup> cell. A new rebalance cell was developed to maintain reactant ionic balance. The cell successfully reduced ferric ions in the iron reactant stream to ferrous ions while chloride ions were oxidized to chlorine gas.					
17. Key Words (Suggested by Author(s))  Electrochemistry; Redox; Energy storage; Flow batteries			18. Distribution Statement  Unclassified - unlimited STAK Category 44 DOE Category UC-94c		
19. Security Classif. (of this report) Unclassified		20. Security Classif. (of this page) Unclassified		21. No. of pages	22. Price* A02