

C.I.



(NASA-CR-171884) IGNITION CHARACTERIZATION
OF LOX/HYDROCARBON PROPELLANTS Final Report
(Aerojet TechSystems Co.) 142 p
HC A07/MF A01

NE5-29070

CSC 11

Unclass

63/28 21611

Ignition Characterization Of LOX/Hydrocarbon Propellants

Contract NAS 9-16639

Final Report

30 April 1985

Prepared For:

NASA - Lyndon B. Johnson Space Center

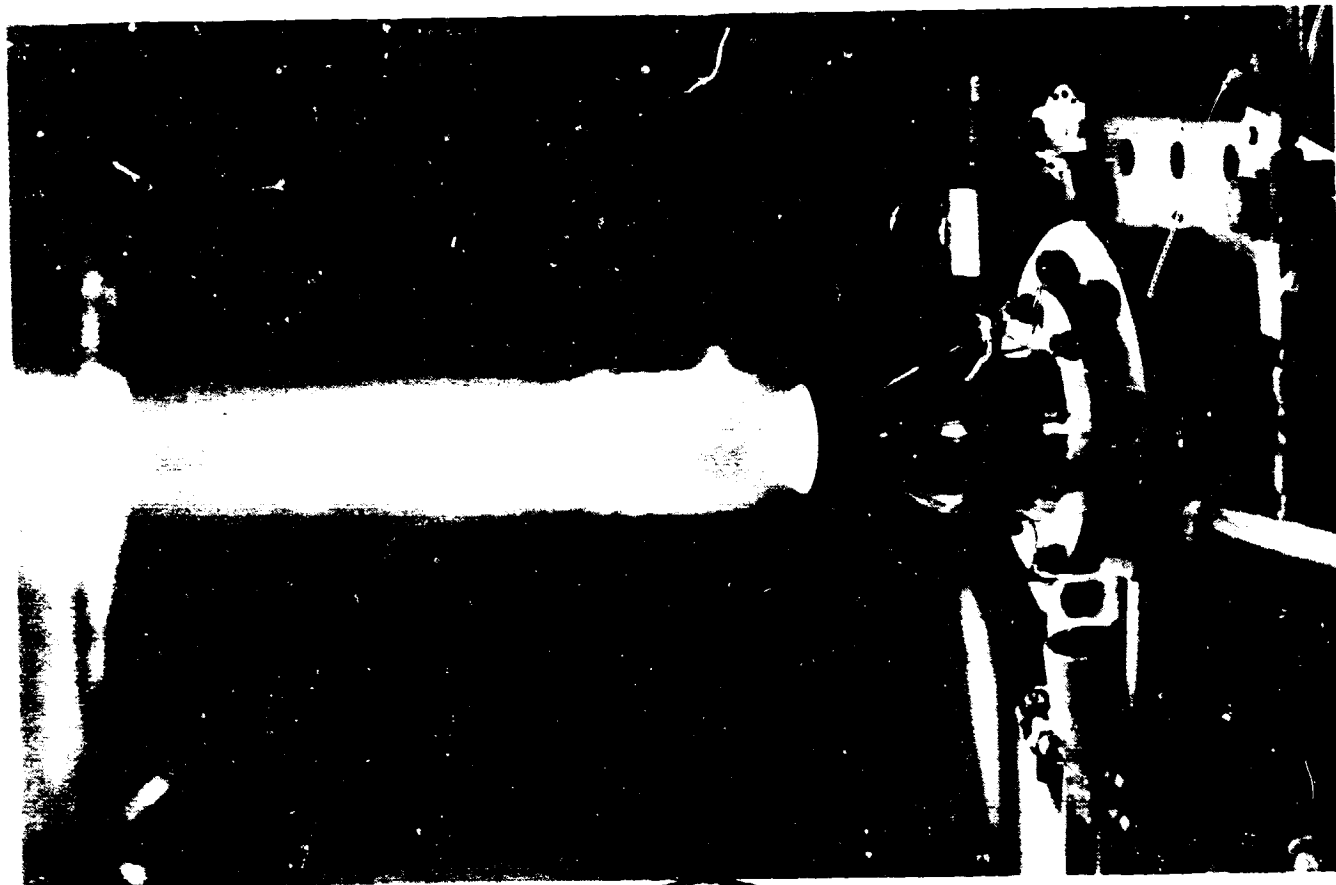

Aerojet
TechSystems
Company

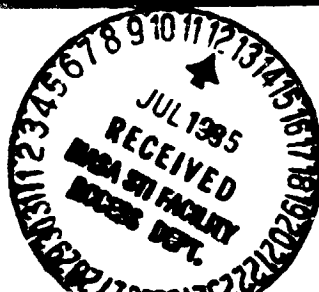

Final Report

30 April 1985

IGNITION CHARACTERIZATION OF
LOX/HYDROCARBON PROPELLANTS

Contract NAS 9-16639

Prepared For

NASA-Lyndon B. Johnson Space Center
Houston, Texas

B. R. Lawver

D. C. Rousar

K. Y. Wong

Aerojet TechSystems Company
P.O. Box 13222
Sacramento, California 95813

RPT/AA0174

FOREWORD

This final report is provided in partial fulfillment of contract NAS 9-16639, Ignition Characterization of LOX/Hydrocarbon Propellants. The program was conducted for the NASA-Johnson Space Center by the Aerojet TechSystems Company under the cognizance of W. C. Boyd, technical monitor. At Aerojet, the project engineers were B. R. Lawver and K. Y. Wong, and the program managers were R. W. Michel and D. C. Rousar. The technical work was performed during the period 6 July, 1982 to 31 July, 1984.

Significant contributions to this program were made by the following Aerojet personnel:

B. J. Anderson	W. G. Hooper
B. D. Bates	A. R. Keller
B. W. Cathroe	H. H. Mueggenburg
R. L. Ewen	J. L. Pieper
J. C. Farig	R. J. Pruett
R. S. Gross	W. A. Thompson
R. Hernandez	

PRECEDING PAGE BLANK NOT FILMED

ABSTRACT

This report presents the results of an evaluation of the ignition characteristics of the Gox/Ethanol propellant combination. Ignition characterization was accomplished through the analysis, design, fabrication and testing of a spark initiated torch igniter and prototype 620 lbf thruster/igniter assembly. The igniter was tested over a chamber pressure range of 74 to 197 psia and mixture ratio range of 0.778 to 3.29. Cold (-92° to -165°F) and ambient (44° to 87°F) propellant temperatures were used.

Spark igniter ignition limits and thruster steady-state and pulse mode, performance, cooling and stability data are presented. Spark igniter ignition limits are presented in terms of cold flow pressure, ignition chamber diameter and mixture ratio. Thruster performance is presented in terms of vacuum specific impulse versus engine mixture ratio.

Gox/Ethanol propellants were shown to be ignitable over a wide range of mixture ratios. Cold propellants were shown to have a minor effect on igniter ignition limits. Thruster pulse mode capability was demonstrated with multiple pulses of 0.08 sec duration and less.

TABLE OF CONTENTS

	<u>Page</u>
I. Introduction and Summary	1
II. Results	5
III. Conclusions & Recommendations	19
IV. Technical Discussion	21
A. Design, Analysis, and Fabrication	21
B. Testing	59
C. Data Analysis	91
References	133

LIST OF TABLES

<u>Table No.</u>		<u>Page</u>
i	Task I Igniter Test Variables	8
II	Swirler/Like Doublet OFO Injector Performance Summary Added Scope Tests	15
III	Task I Igniter Hardware List	24
IV	Prototype Thruster Design Criteria	32
V	Task III Hardware List	35
VI	Summary of Predicted Igniter Characteristics	44
VII	Igniter Injector Cold Flow Results	60
VIII	Power Supply Specifications GLA Model 30344 Variable-Energy System	66
IX	Task I Igniter Instrumentation List	67
X	Task I Gox/Ethanol Ignition and Durability Test Matrix	69
XI	Added Scope Planned Gox/Ethanol Test Matrix	76
XII	Task III Thruster Instrumentation List	81
XIII	Task III Igniter Test Matrix	83
XIV	Task III Thruster Test Matrix	85
XV	Task I Igniter Pulse Test Summary	100
XVI	Gas Generator Test Summary	103
XVII	Task III Igniter Test Conditions	106
XVIII	Task III Igniter Test Results	107
XIX	Performance Summary - Heat Sink Chamber	111
XX	Igniter Operating Conditions - Heat Sink Chamber	115
XXI	Performance Data Summary - Thin Wall Chamber	116
XXII	Pulse Performance Data Summary	126

LIST OF FIGURES

<u>Figure No.</u>		<u>Page</u>
1	Task I Prototype Igniter and Test Fixtures	6
2	Gox/Ethanol Igniter Test 281	7
3	Gox/Ethanol Flame Quench Ignition Limits	9
4	Effect of Spark Energy and Cold Fuel on Flame Quench Ignition Limits	10
5	Igniter Steady State C* Performance - 93% Fuel Coolant	11
6	Task III Prototype Thruster Assembly	13
7	Gox/Ethanol Thruster Test 135	14
8	Thruster C* and Isp Efficiency	16
9	Thruster Bit Isp	17
10	Typical Thruster Pulse Sequence (Thruster Test 183)	18
11	Spark Initiated Torch Ignition Process	22
12	Task I Igniter Hardware	25
13	Fuel Cooled Igniter Chamber	26
14	Added Scope - Thruster Test Assembly	27
15	Mid-Pc Fuel Film Coolant Ring	28
16	Mid-Pc Gox/Ethanol Swirler/Like Doublet OFO Injector	30
17	Mid-PC Gox/Ethanol Swirler/Like Doublet OFO Injector Pattern	31
18	Prototype Thruster Assembly	34
19	Gox/Ethanol Pulse Thruster Injector	36
20	Gox/Ethanol Injector Cutaway	37
21	Gox/Ethanol Swirler/Like Doublet OFO Injector Element Concept	39
22	Fuel Film - Coolant Injection Schemes	40
23	Fuel Circuit Cold Flow - Tangential FFC	41
24	Copper Heat Sink Chamber Section	43
25	Mid-Pc Heat Sink Nozzle	44
26	Thruster Thin-Wall Chamber	45
27	Propane Flow Rate vs ΔP	48
28	Methane Flow Rate vs ΔP	49
29	LOX Flow Rate vs ΔP	50

LIST OF FIGURES (cont.)

<u>Figure No.</u>		<u>Page</u>
30	Flame Quench Parameter, Propane/Oxygen	51
31	Flame Quench Parameter, Methane/Oxygen	52
32	Igniter Manifold Assembly Drawing	53
33	Igniter Manifold Drawing	54
34	Completed Igniter Injector Assemblies	55
35	Completed Igniter Manifolds	56
36	Closeup View of Completed Igniter Injector	57
37	Igniter Injector Flow Schematic	58
38	Gox/Ethanol Ignition Test Flow Schematic	62
39	Task I Igniter Test Setup	64
40	Igniter Solenoid Valve Schematic	65
41	Task I Igniter Instrumentation Locations	67
42	Task I Ignition Test Sequence	72
43	Space Shuttle RCS Engine Envelope	74
44	Bay 6 Test Facility	75
45	Bay 6 Test Facility Flow Schematic	78
46	Task III Igniter Testing Instrumentation Locations	80
47	Task III Thruster Testing Instrumentation Locations	82
48	Thruster Ignition Sequence - Steady State Testing	86
49	Thruster Pulse Sequence - GN ₂ Actuator	89
50	Thruster Pulse Sequence - GHe Actuator	90
51	Effect of Igniter Chamber Diameter and Cold-Flow Pressure on Ignition	92
52	Effect of Spark Energy on Ignition	94
53	Effect of Cold Propellant on Ignition	95
54	Effect of Fuel and Ox Temperature on Ignition	96
55	Cooled Igniter Chamber Ignition Limits	97
56	Igniter Heat Flux Correlation	99
57	Igniter Pulse Mode Sequence - Ambient Propellant	101
58	Effect of Fuel Film Coolant on Performance	104
59	Gox/Ethanol Igniter Firing	108

LIST OF FIGURES (cont.)

<u>Figure No.</u>		<u>Page</u>
60	Ignition Limit Data - Task III Igniter Testing	110
61	Thruster Isp Performance - Heat Sink Chamber	112
62	Thruster Isp Efficiency - Heat Sink Chamber	113
63	Thruster Isp Performance - Tangential FFC	118
64	Thruster Isp Performance - Tangential and Swirl FFC	119
65	Thruster Isp Performance - Ambient and Cold Propellant	121
66	Throat Wall Temperature History - Tangential FFC (Test 135)	122
67	Thruster Wall Temperature Profiles - Tangential FFC (Test 135)	123
68	Effect of Fuel Film Cooling on Predicted Thruster Adiabatic Wall Temperature	124
69	Effect of Pulse Width on Bit Impulse - Nominal Inlet Pressures	129
70	Effect of Inlet Pressures (MR) on Bit Isp	130
71	Effect of Pulse Width on Bit Impulse - Cold Propellants	131
72	Effect of Pulse Width on Bit Isp - Cold Propellants	132

I. INTRODUCTION AND SUMMARY

Recent studies indicate that future space transportation system (STS) engine development and operational recurring costs may be reduced through the use of low cost oxygen/hydrocarbon propellants in the auxiliary propulsion system (orbital maneuvering, reaction control, and vernier engines). The storable propellants (nitrogen tetroxide/monomethylhydrazine) used on the current STS are toxic and considerably more expensive than oxygen/hydrocarbon propellants. These propellants were selected over the oxygen/hydrocarbon propellants because a more extensive storable propellant thruster data base existed at that time. Also, the storable propellants are hypergolic and this eliminated the need for external ignition sources which were considered to be less reliable.

During the past five (5) years, several studies have been conducted for the purpose of expanding the oxygen/hydrocarbon thruster data base. Previous studies have examined the combustion performance and cooling characteristics of LOX/RP-1, LOX/propane, LOX/methane and LOX/ethanol. The objective of this study was to characterize the ignition and pulse mode capability of promising oxygen/hydrocarbon propellants for long-life, reusable, STS application. GOX/ethanol propellants were selected for testing on the basis of their demonstrated clean burning characteristics (Ref. 1) and because of the system advantages indicated for this propellant combination in the study reported in Reference 2.

In this program, a prototype 620 lbf GOX/ethanol RCE thruster with spark-initiated torch igniter was designed, fabricated and tested over a wide range of inlet conditions. The prototype igniter was used to determine the fundamental spark ignition characteristics of GOX/ethanol propellants prior to thruster testing. These ignition characteristics included the effects of igniter chamber diameter, cold-flow pressure level (inlet pressure), spark energy, and inlet temperature. An integral thruster/igniter assembly was used to evaluate thruster pulse mode capability with the GOX/ethanol propellant combination. The thruster was demonstrated to be ignitable over the whole

I, Introduction and Summary (cont.)

range of inlet conditions. All of the tests demonstrate smooth combustion with no evidence of combustion instability. The exhaust plumes were clean with no evidence of soot or carbon deposition. Pulse mode capability was demonstrated with pulse durations down to 40 msec.

The program consisted of five parts: (1) Task I - Igniter Experimental Evaluation; (2) Task II - Preliminary Design; (3) Added Scope Testing with Contract NAS 9-16639 Test Hardware; (4) Task III - Thruster Experimental Evaluation; and (5) Added Scope Igniter Design and Fabrication.

The objectives of Task I were to determine the fundamental spark ignition characteristics of GOX/ethanol propellants. These characteristics include the effects of design and operating variables such as igniter chamber size, cold-flow pressure level, spark energy, igniter cooling requirements, pulse mode capability and oxidizer manifold fuel contamination. A prototype igniter was designed, two assemblies fabricated and 205 hot fire tests conducted. The ignition testing covered a mixture ratio range of 0.4 to 40 and a cold-flow pressure range of 3.3 to 49 psia. Igniter chamber cooling tests covered a mixture ratio range of 0.4 to 1.3 and chamber pressures of 72 to 195 psia. The igniter was pulsed with a 0.2 second on and 0.2 second off duty cycle to demonstrate igniter pulse mode capability. Propellant temperatures ranged from 80°F to -165°F.

A secondary objective was to evaluate the carbon formation potential of fuel rich gas generator mixtures. This was accomplished by designing a gas generator chamber with an internal secondary injector to fit the igniter injector. Nine (9) tests were run over mixture ratio range of 0.189 to 0.441. No evidence of carbon formation was observed. Detailed Task I results are reported in the Task I data dump, Reference 3.

The objective of Task II was to analytically evaluate the ignition, performance and cooling requirements of GOX/ethanol igniters and thrusters for auxiliary propulsion applications. The results of these evaluations were used

I, Introduction and Summary (cont.)

to guide the Task I & III igniter and thruster design activities. These results are reported in the Task II Data Dump, Reference 4.

The objective of the added scope testing was to get an early evaluation of combustion performance of GOX/ethanol thrusters for auxiliary propulsion applications. These tests were conducted using residual hardware from the Mid Pc Program (NAS 9-15958) and the test results were an aid to the Task III thruster design activity. Nineteen hot fire tests were run over the chamber pressure range of 95 to 303 psia and mixture ratio range of 1.07 to 2.35 with ambient (70°F) and cold (-125°F) propellants. Fuel film-coolant was varied from 0% to 20.8%. The Mid-Pc swirler/OFO injector pattern was selected for the Task III thruster on the basis of these results. Complete details are presented in the WBS 8.0 Data Dump, Reference 5.

The primary objective of the Task III testing was to experimentally evaluate GOX/Ethanol thruster ignition and pulse mode operation. A secondary objective was to evaluate thruster steady-state performance, cooling and stability characteristics. A prototype thruster consisting of an igniter, injector, and thrust chamber was tested over a wide range of propellant inlet temperatures and pressures. The testing was conducted in two parts. The first part checked out the Task I GOX/Ethanol igniter in the thruster test facility. Nineteen (19) tests were run to evaluate the igniter feed system, valve timing, and propellant inlet condition effects. The second part addressed full thruster operation. Sixty five (65) thruster tests were conducted. Thirteen (13) tests were run with a heat sink chamber to evaluate ignition and inlet condition effects on performance. Fifty two (52) tests were run with a thin-wall chamber to evaluate film-coolant effectiveness and pulse mode performance over a range of inlet conditions. These Task III thruster tests were run over the mixture ratio range of 0.778 to 3.29 and chamber pressure range of 74 to 197 psia. Propellant temperatures ranged from ambient down to -156°F. Detailed data are presented in the Task III Data Dump, Reference 6.

I. Introduction and Summary (cont.)

The objective of the added scope design and fabrication tests was to design and fabricate two (2) additional igniter injectors for ignition testing with LOX/liquid methane and LOX/liquid propane propellants. Ignition testing will be conducted at NASA/JSC. The data obtained will expand the LOX/hydrocarbon propellant ignition data base for thruster applications.

II. RESULTS

The ignition and steady-state performance characteristics of spark ignited GOX/Ethanol propellants were defined and pulse mode capability was demonstrated. The prototype igniter shown in Figures 1 and 2 was designed, fabricated and tested over the range of conditions listed in Table I. A total of one hundred thirty eight (138) igniter tests were run to define the ignition limits in terms of cold flow pressure, ignition chamber diameter, mixture ratio, spark energy and propellant temperature.

The effect of cold flow pressure (P) and chamber diameter (D) on the flame quench ignition limits were correlated by plotting their product (PXD) versus the mixture ratio as shown in Figure 3. Cold (-125°F) fuel was found to only slightly reduce the ignition limits. Cold oxidizer had no measurable effect on ignition. Reducing the spark energy from 50 mj/spk to 10 mj/spk had a more significant effect on the ignition limit as indicated in Figure 4.

Complete mapping of the fuel rich regime could not be accomplished without making hardware changes beyond the scope of the current program. The changes involve designing a second igniter injector with larger fuel passages and smaller oxidizer passages to maintain fuel and oxidizer inlet pressures and injector velocities within reasonable limits. The igniter injector design could possibly be modified to incorporate either fuel-rich or ox-rich platelet stacks by utilizing a "bolt-on" stack design rather than the current "brazed-on" design. Therefore, it is recommended that future ignition work completely explore the fuel rich regime.

Sixty seven additional igniter tests were run to verify igniter cooling, C* performance and pulse mode capability. The igniter C* performance is shown in Figure 5. Performance was deemed to be satisfactory for Task III thruster application. Adequate cooling was demonstrated with 93% fuel coolant. Pulse mode capability was demonstrated by running a series of pulse tests with both ambient and cold (-125°F) propellants. Ignition was achieved at all conditions where ignition was predicted.

Igniter Test Assembly

ORIGINAL DRAWING
OF POOR QUALITY

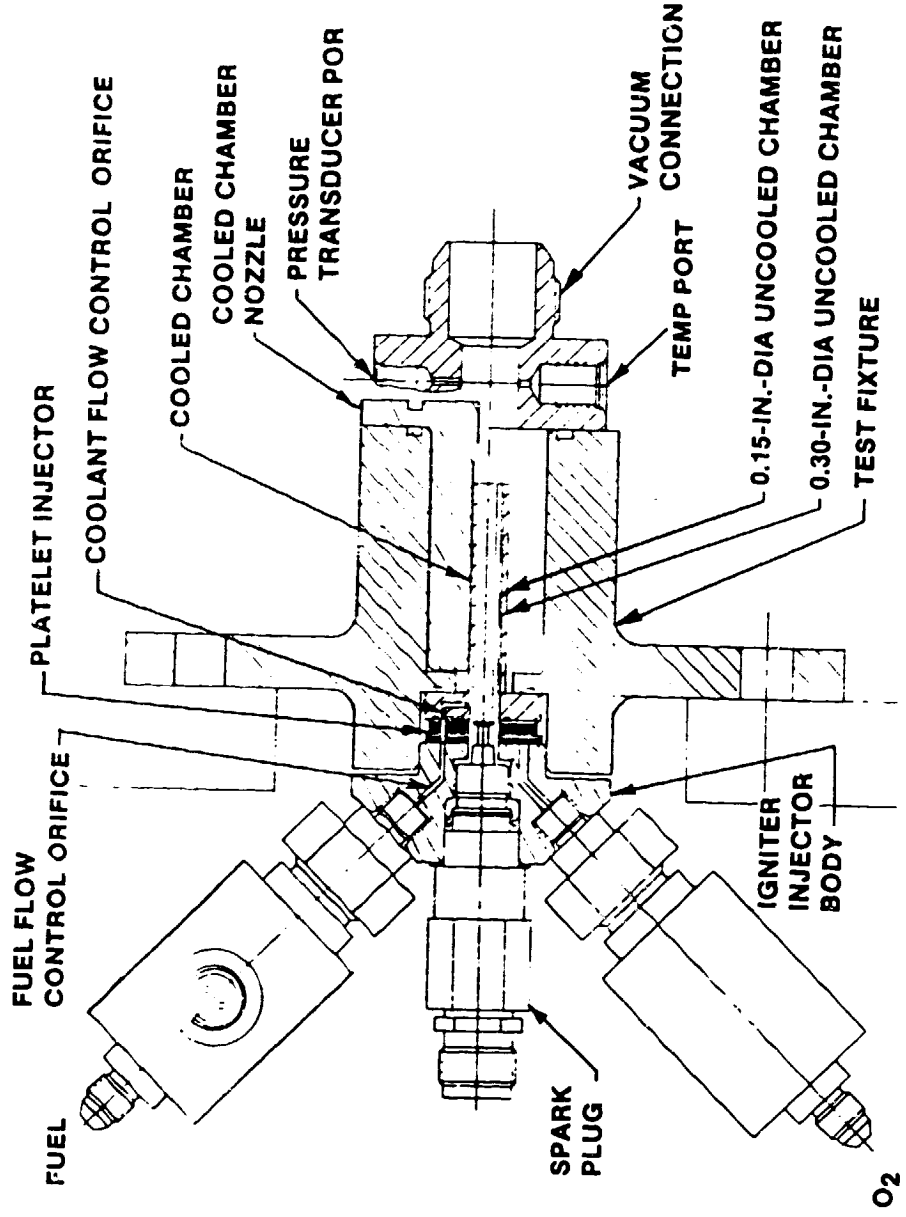

Figure 1. Task I Prototype Igniter and Test Fixture

OF POOR QUALITY



C0583155

Figure 2. Gox/Ethanol Igniter Test 281

TABLE I

TASK I IGNITER TEST VARIABLES

- Propellant Temperature
 - Amb 44 to 80°F
 - Cold -92 to -165°F

- Cold Flow Pressure
 - 3.3 - 49 psia

- Chamber Diameter
 - 0.15 in.
 - 0.30 in.

- Mixture Ratio
 - 0.4 - 40

- Spark Energy
 - 10 - 50 mJ

- Spark Rate
 - 300 SPS (Fixed)

- Spark Gap
 - 0.025 in. (Fixed)

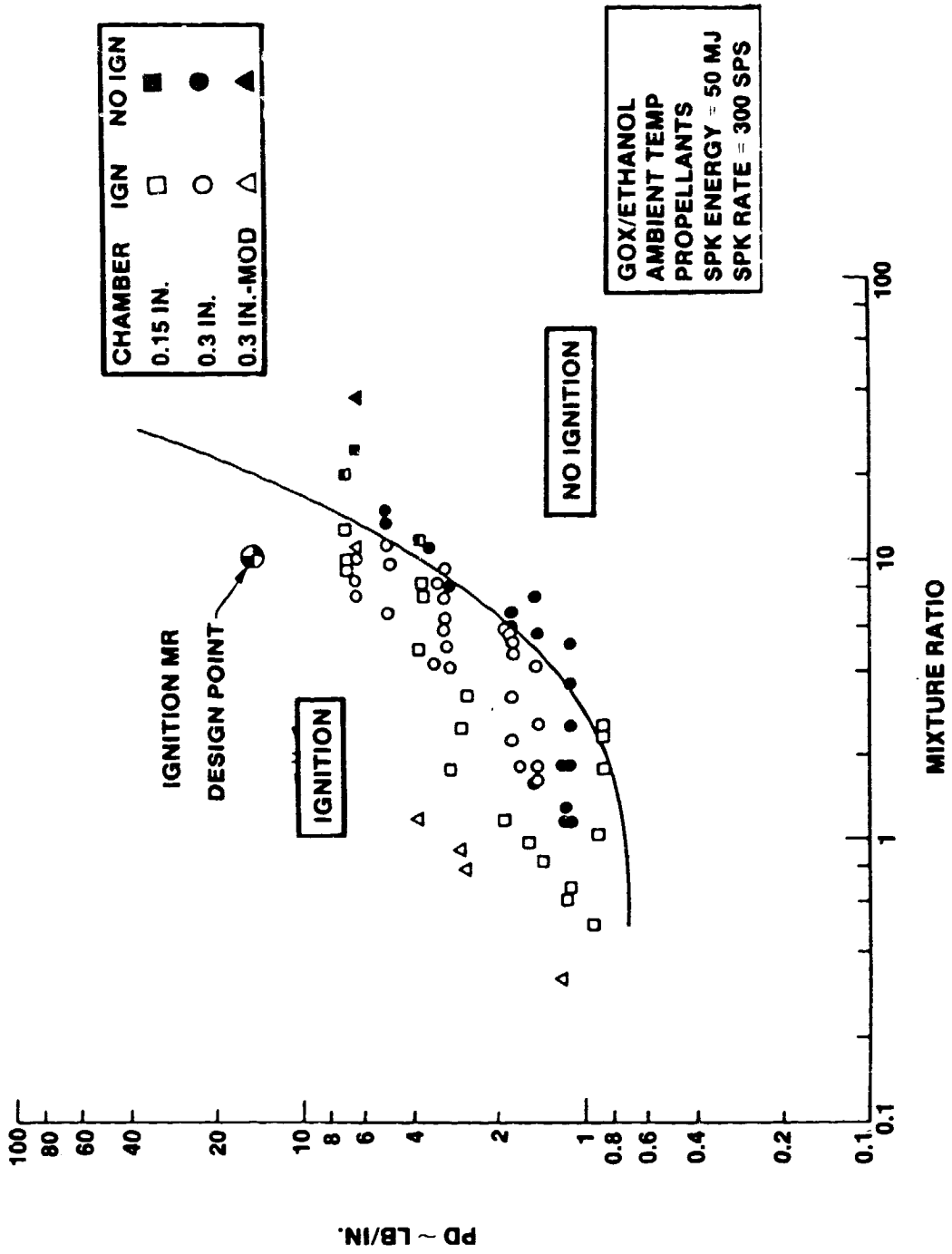

Figure 3. GOX/Ethanol Flame Quencher Ignition Limits

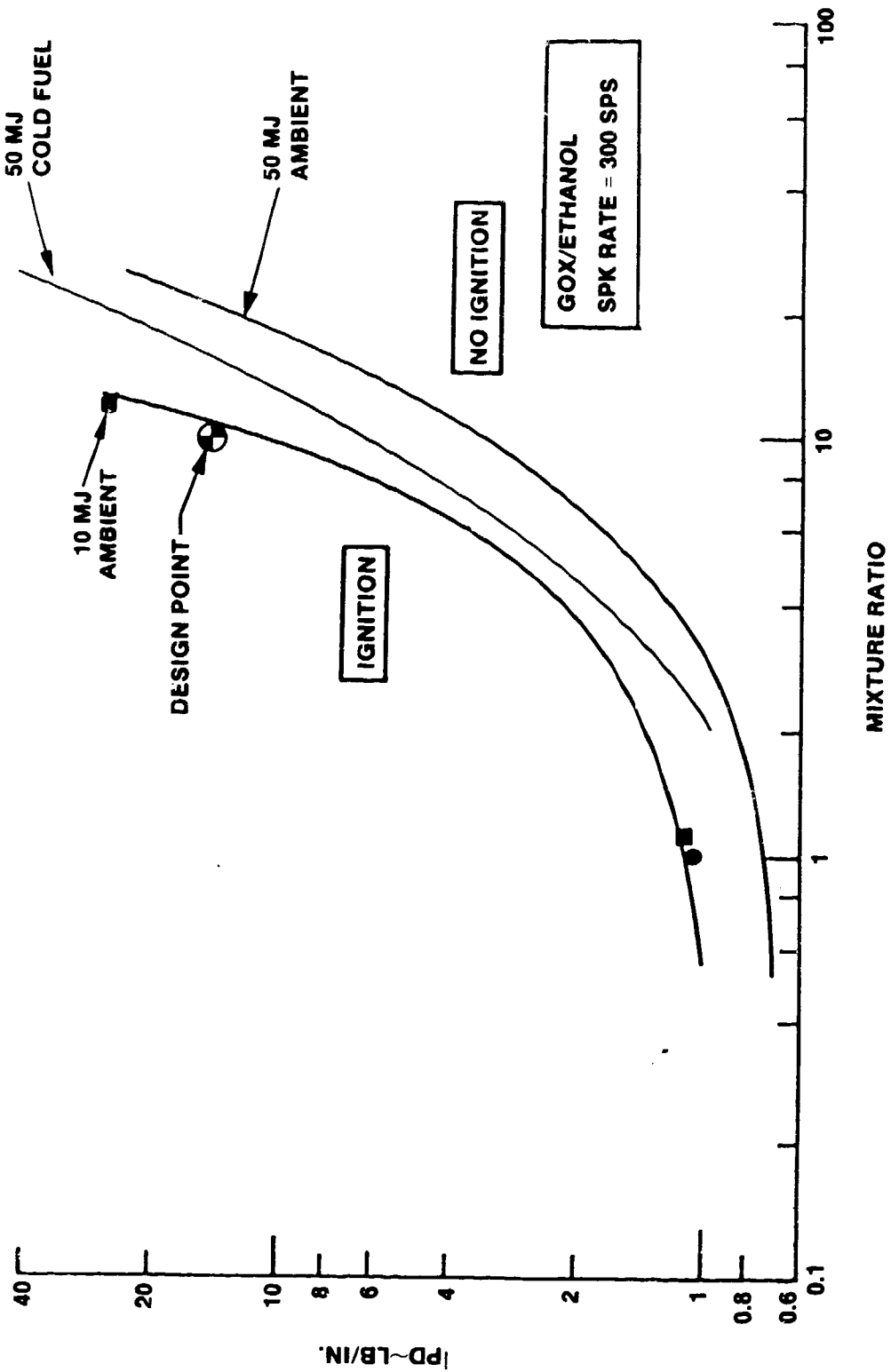
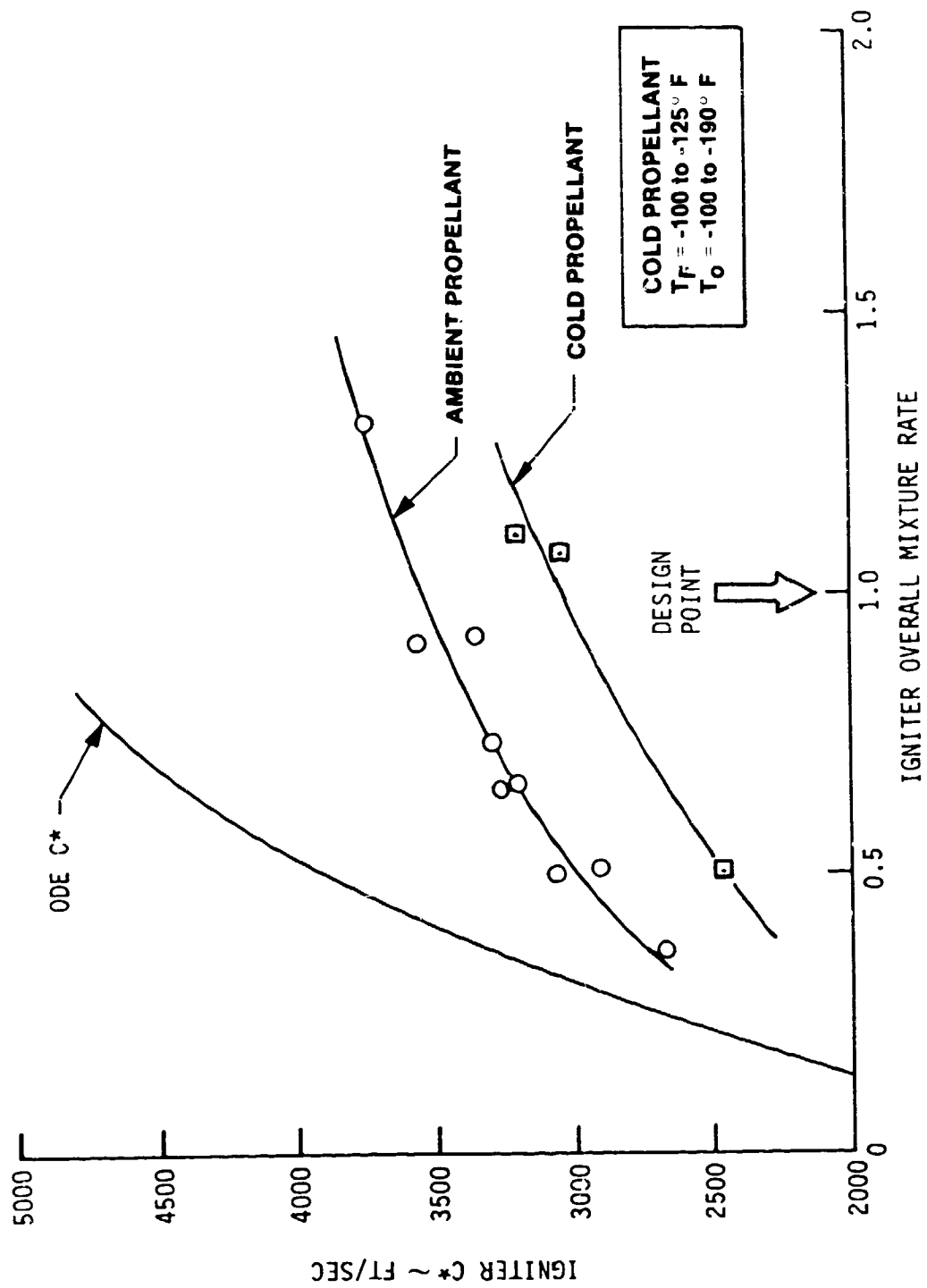

Figure 4. Effect of Spark Energy and Cold Fuel on Flame Quench Ignition Limits



COLD PROPELLANT
 $T_F = -100$ to $-125^\circ F$
 $T_O = -100$ to $-190^\circ F$

Figure 5. Igniter Steady State C* Performance - 93% Fuel Coolant

II, Results (cont.)

A total of eighty-four (84) thruster tests were conducted. Nineteen (19) added scope tests were made using residual hardware (contract NAS 9-15958) and sixty-five (65) tests were made using the prototype thruster designed and fabricated on this program and shown in Figures 6 and 7. The results of the added scope tests are summarized in Table II. These tests confirmed that the performance of the swirler/like doublet OFO injector would be adequate in the 4 inch chamber of the prototype thruster.

The prototype thruster combustion and Isp performances are shown on Figure 8 for ambient and cold propellant. The ambient temperature performance is nearly flat over the whole range of mixture ratio tested. The cold propellant reduces efficiency by about 6% at the design point mixture ratio.

The thin-wall chamber thermocouple data indicate that 40% FFC will be required to cool a columbium radiation cooled flight engine which operates at thermal steady state. Additional testing will be required to verify this requirement and to define performance for 40% FFC.

The thruster pulse performance was determined over a pulse width range of 40 msec to 500 msec. The Bit Isp is shown in Figure 9. A typical pulse sequence is shown in Figure 10.

All of the thruster tests were smooth with no evidence of combustion instability. The exhaust plume was observed to be clear and clean. No evidence of carbon formation or deposition was found.

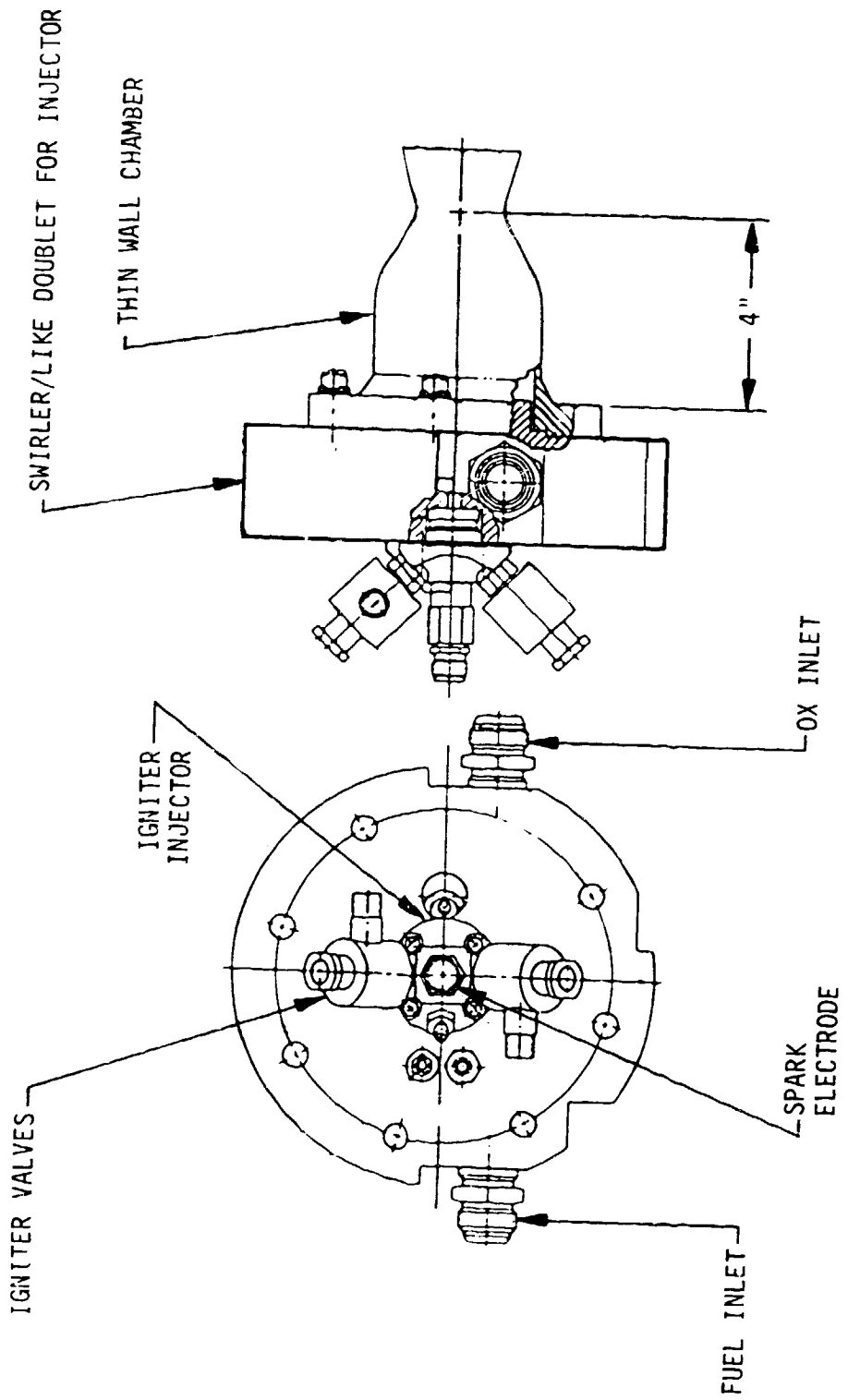

Figure 6. Task III Prototype Thruster Assembly

ORIGINAL PHOTOGRAPH
OF POOR QUALITY



C1083 062

Figure 7. G0X/Ethanol Thruster Test 135

TABLE II

SWIRLER/LIKE DOUULET OFO INJECTOR PERFORMANCE SUMMARY
 ADDED SCOPE TESTS

Chamber L' = 4.7 in.

MRENG = 1.8

Nominal Propellant Temperature (°F)	Chamber Pressure (psia)	Fuel Film Coolant (%)	Measured Combustion Efficiency (%)	Predicted Combustion Efficiency (%)
40	150	0	96-97	96
40	150	10	94-95	-
40	150	15	91-92	-
40	150	20	92-93	95
40	300	0	98-99	-
40	300	20	93-95	-
-100	150	0	91-92	-
-100	150	10	90-91	-
-100	150	16	89-92	81
-100	300	16	89-92	-

Chamber L' = 8.7 in.

40	150-300	0	98.5-100	-
40	150-300	20	95-97	-

GOX/ETHANOL PROPELLANTS
 L = 4 inches
 FFC - 25%
 Thin Wall Chamber, Swirl FFC
 $\epsilon = 2/1$
 Open - Ambient Fuel
 Closed - Cold Fuel
 ○ - η_{C^*}
 □ - η_{Isp}

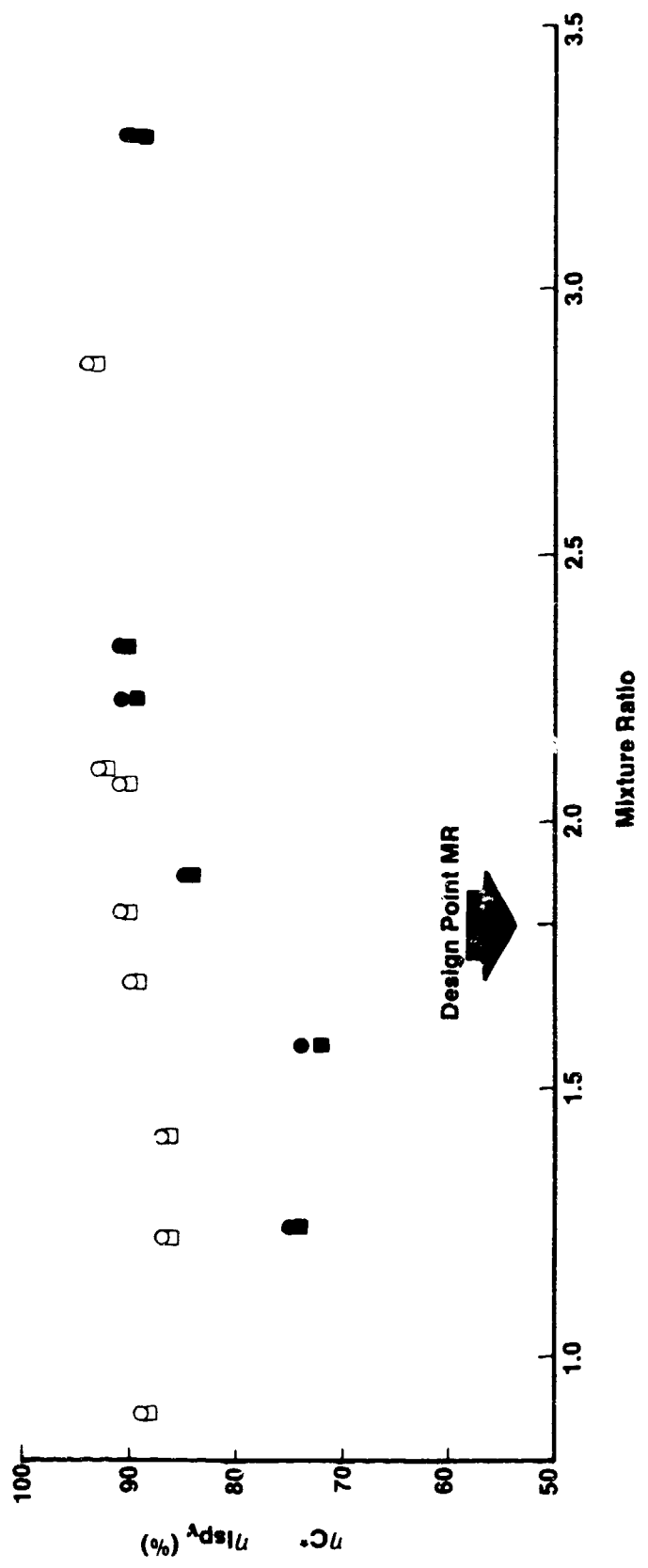

Figure 8. Thruster C^* and Isp Efficiency

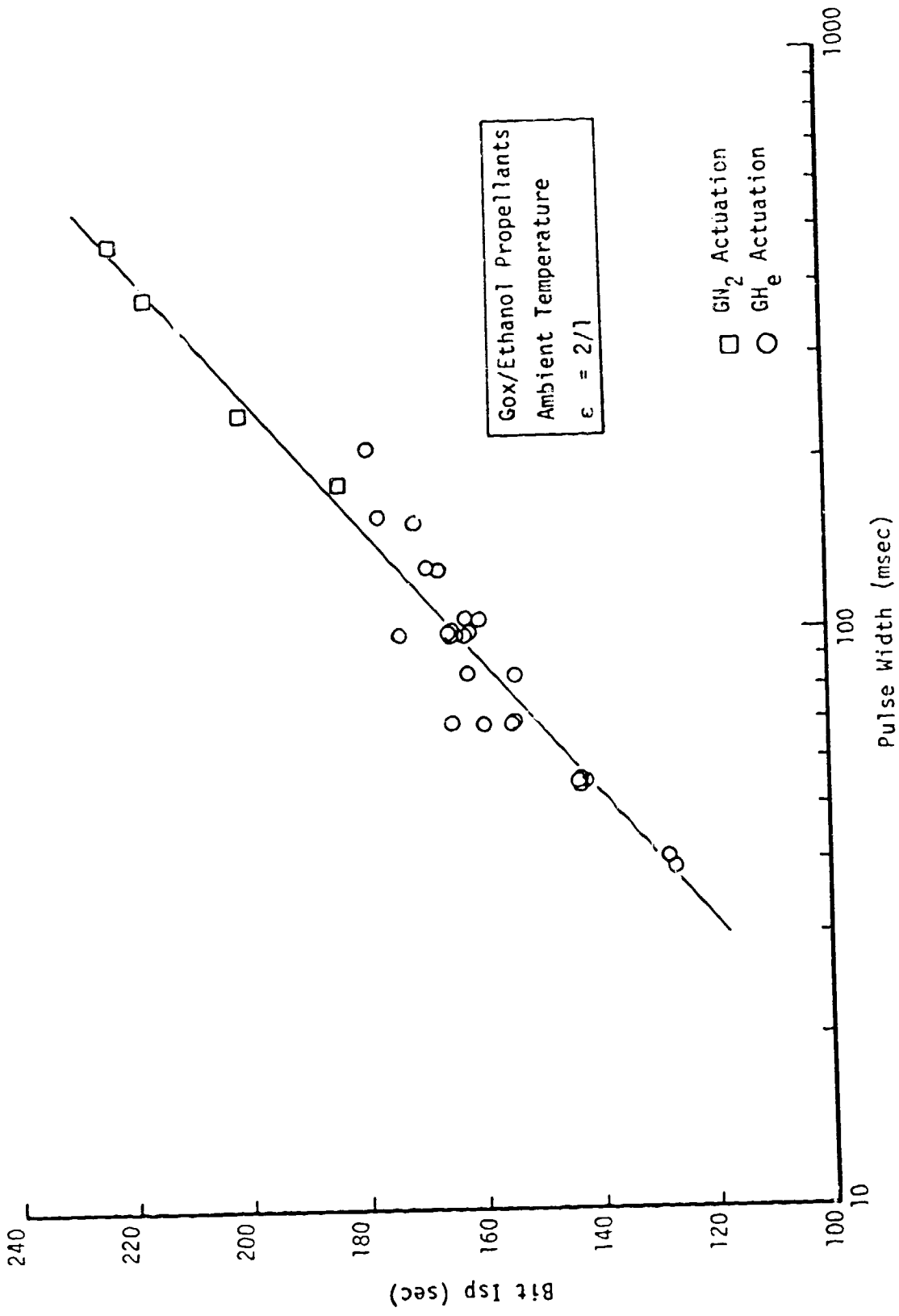

Figure 9. Thruster Bit Isp

Pulse Train With Cold Propellant

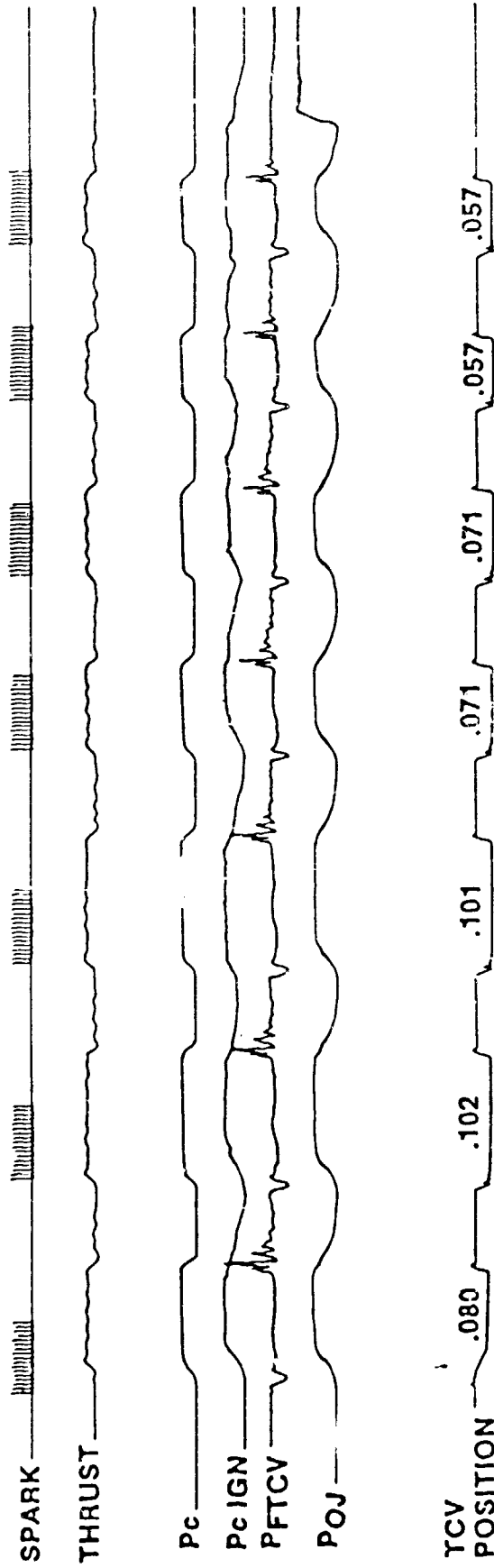

Figure 10. Typical Thruster Pulse Sequence (Thruster Test 183)

III. CONCLUSIONS AND RECOMMENDATIONS

The following conclusions and recommendations are drawn:

1. GOX/ethanol has broader mixture ratio ignition flame quenching limits on the fuel-rich side than predicted.
2. GOX/ethanol has higher cold-flow ignition flame quenching limits than predicted.
3. The extreme fuel-rich flame quenching mixture ratio limits could not be defined due to hardware limitations.
4. Cooling of igniter chambers is adequate over the range of conditions tested.
5. Cold ethanol (-125°F) slightly reduces the ignition mixture-ratio limit. Cold oxygen (-165°F) has no apparent effect.
6. Reducing spark energy from 50 millijoules to 30 milli-joules reduces the ignition mixture ratio limits.
7. Fuel-rich (MR = 0.2 - 0.4) GOX/ethanol gas generator exhaust gases are carbon-free.
8. Extreme fuel-rich (MR < 0.1) igniter testing is recommended to define the fuel-rich flame quench limits.
9. GOX/Ethanol thrusters are ignitable over a broad range of inlet pressures (200 to 600 psia) and temperatures (65°F to -156°F).

III, Conclusions and Recommendations (cont.)

10. GOX/Ethanol thrusters can be operated in a pulse mode with pulse as short as 0.040 sec.
11. Thruster performance (93% Isp) is adequate for Space Shuttle auxiliary propulsion applications with 25% FFC.
12. Fuel film cooling of about 40% may be required for radiation cooled thrusters using swirl FFC injection.
13. Further GOX/Ethanol thruster testing should evaluate film coolant injection techniques and determine performance and throat adiabatic wall temperature as a function of film coolant flow rate in the 25-40% range.

IV. TECHNICAL DISCUSSION

A. DESIGN, ANALYSIS, AND FABRICATION

This section of the report describes the analysis, design and fabrication of the igniter and thruster test components.

1. Igniter Hardware Design and Fabrication

The Task I igniter hardware was designed to fulfill the following functions: 1) generate basic ignition flame quenching and spark ignition data, 2) demonstrate satisfactory igniter steady-state operation, 3) demonstrate igniter pulse mode operation and evaluate oxidizer manifold contamination potential, 4) evaluate carbon formation potential of fuel-rich GOX/ethanol combustors, and 5) serve as thruster igniter for Task III testing.

These requirements were accommodated by designing a prototype igniter injector to fit both the Tasks III thruster and a test fixture for the Task I ignition testing. A variety of chambers were designed for the ignition testing.

The igniter design was patterned after previous successful spark initiated GO_2/GH_2 and LOX/RP-1 igniters. The spark-initiated torch chamber ignition process is illustrated in Figure 11; (1) a flame kernel is produced within the spark gap by the spark discharge; (2) the flame kernel spreads and ignites an oxidizer-rich core flow within the igniter chamber; (3) the igniter core flow mixes and reacts with the fuel coolant flow to produce a fuel-rich torch exhaust; and (4) the fuel-rich torch flow reacts with the thruster oxidizer lead flow to ignite the thruster. An oxidizer-rich igniter core mixture ratio has historically been used to provide reliable ignition. Ignition testing on this program indicates that a fuel-rich core mixture ratio will also provide good ignition with ethanol fuel. The core and overall mixture ratios were selected on the basis of the Task II (Ref. 2) ignition

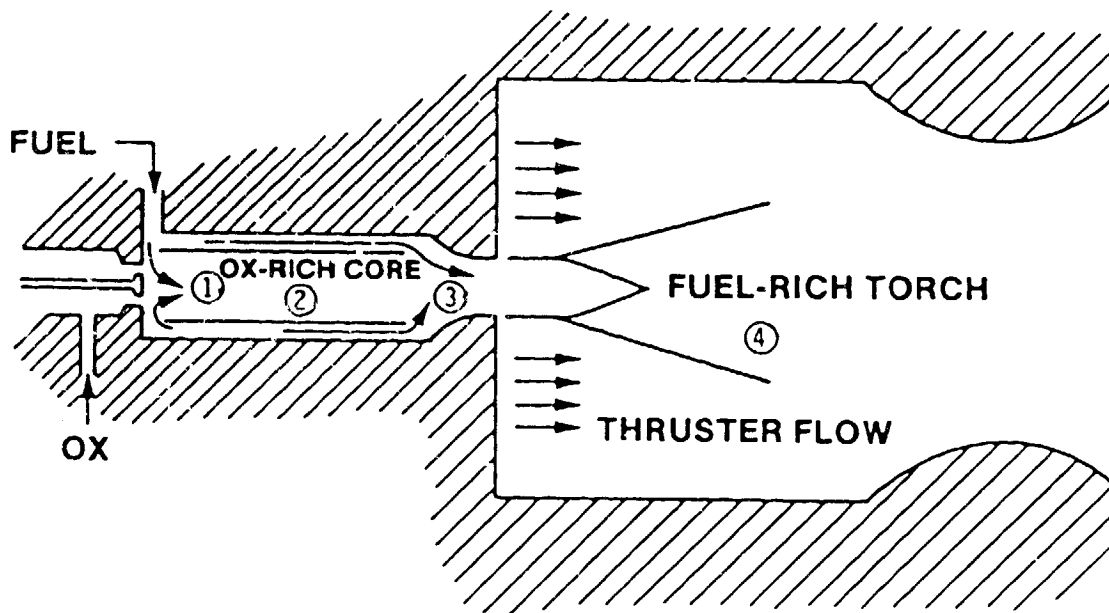

Figure 11. Spark Initiated Torch Ignition Process

IV, A, Design, Analysis, and Fabrication (cont.)

flame quenching and igniter chamber cooling analyses. The steady-state design conditions selected are:

P_{cIGN}	= 150 psia
MR_{core}	= 15
$MR_{overall}$	= 1
Chamber diameter	= 0.200 inches

An assembly drawing of the Task I igniter hardware is shown in Figure 1. The test hardware quantities designed and fabricated are listed in Table III. The hardware consists of an injector assembly, cooled and uncooled igniter chambers, a gas generator chamber, a cooled chamber nozzle adaptor, a test fixture and a vacuum connector. Photographs of the test hardware are shown in Figure 12 and 13. Detailed descriptions of their design and fabrication are given in the Task I Data Dump, Ref. 3.

2. Added Scope Test Hardware

The added scope testing was accomplished using residual hardware from Contract NAS 9-15958 (Mid-Pc program). The hardware assembly is shown schematically in Figure 14. The copper chamber and nozzle heat sink sections were instrumented to measure wall temperatures and combustion pressures.

The fuel film coolant ring is shown in Figure 15. The acoustic resonator is incorporated into the film coolant ring. The resonator is an annular gap 0.085 in. wide with a depth of 0.7 in. There are no cavity partitions. The film coolant is injected from thirty-six (36) 0.015-in. diameter orifices which impinge on the outer rim of the injector as shown in Figure 15.

TABLE III

TASK I IGNITER HARDWARE LIST

<u>Description</u>	<u>Quantity</u>
Igniter Injector Assembly	2
Igniter Body	2
Platelet Stack	2
Uncooled Igniter Chamber - 0.3" dia.	1
Uncooled Igniter Chamber - 0.15" dia.	1
Cooled Igniter Chamber - 0.2" dia.	2
Gas Generator Chamber - 0.5" dia.	1
Cooled Chamber Nozzle	1
Test Fixture	1
Vacuum Connector	1

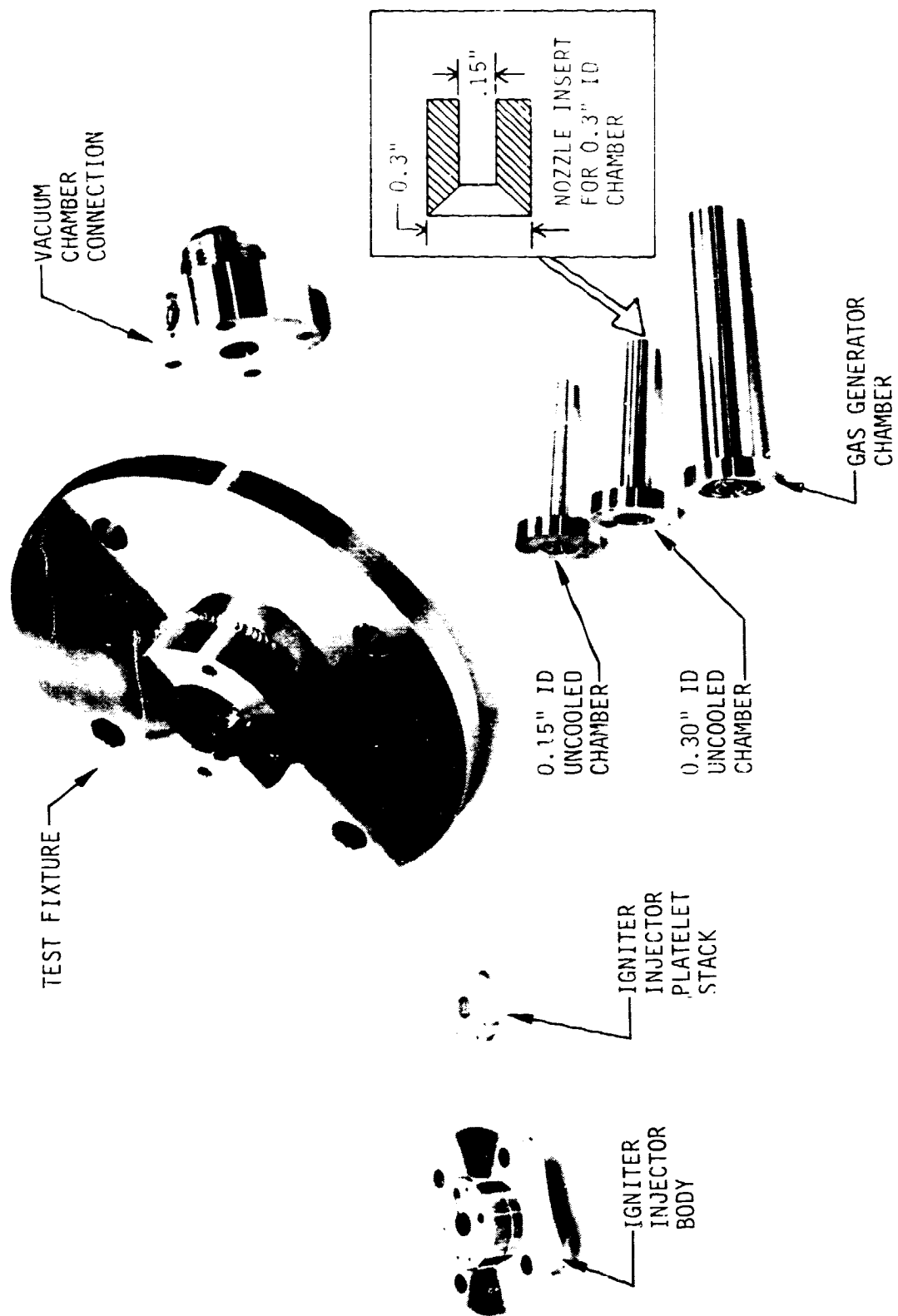

Figure 12. Task I Igniter Hardware

OF ...
OF ...

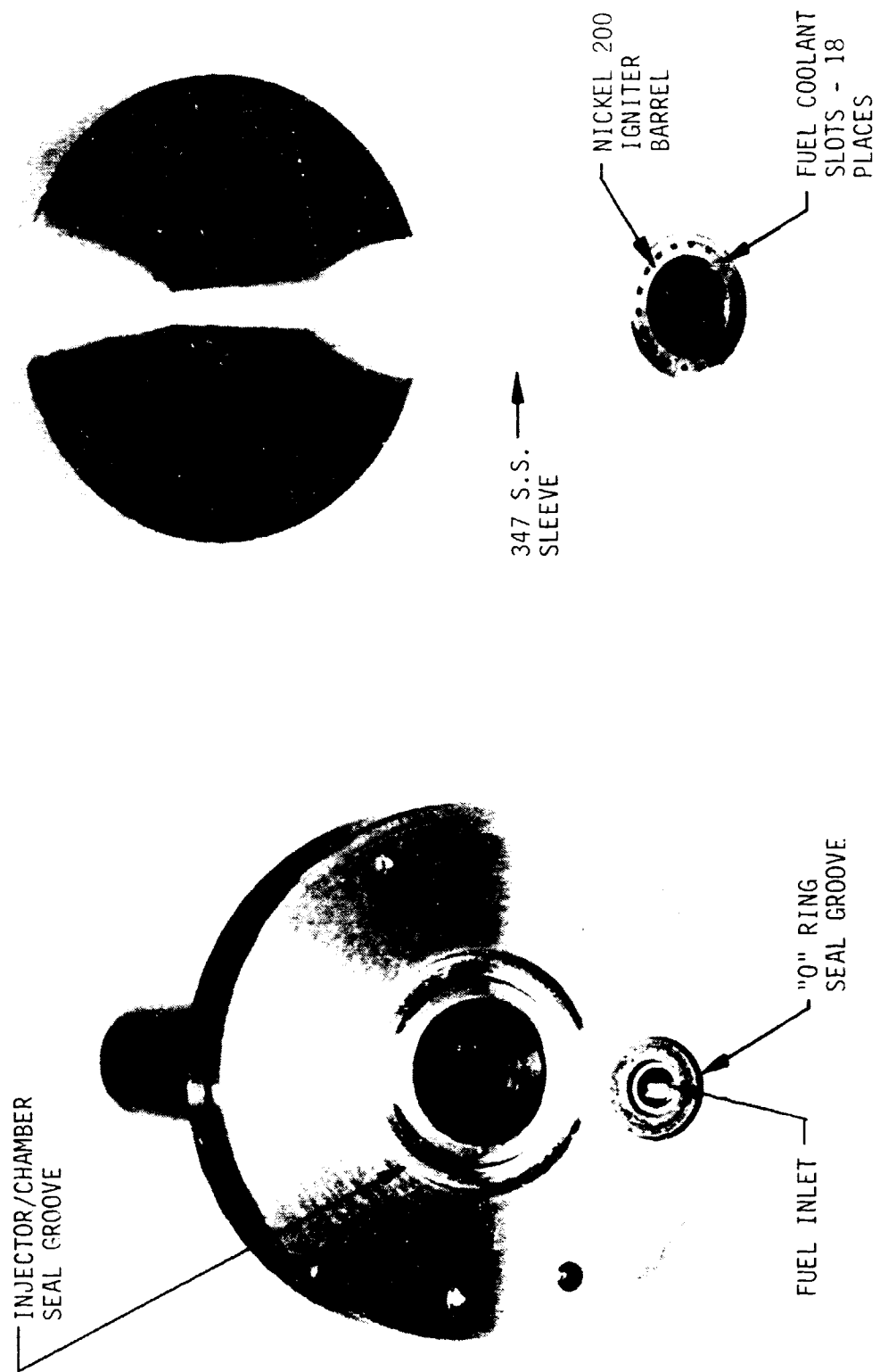

Figure 13. Fuel Cooled Igniter Chamber

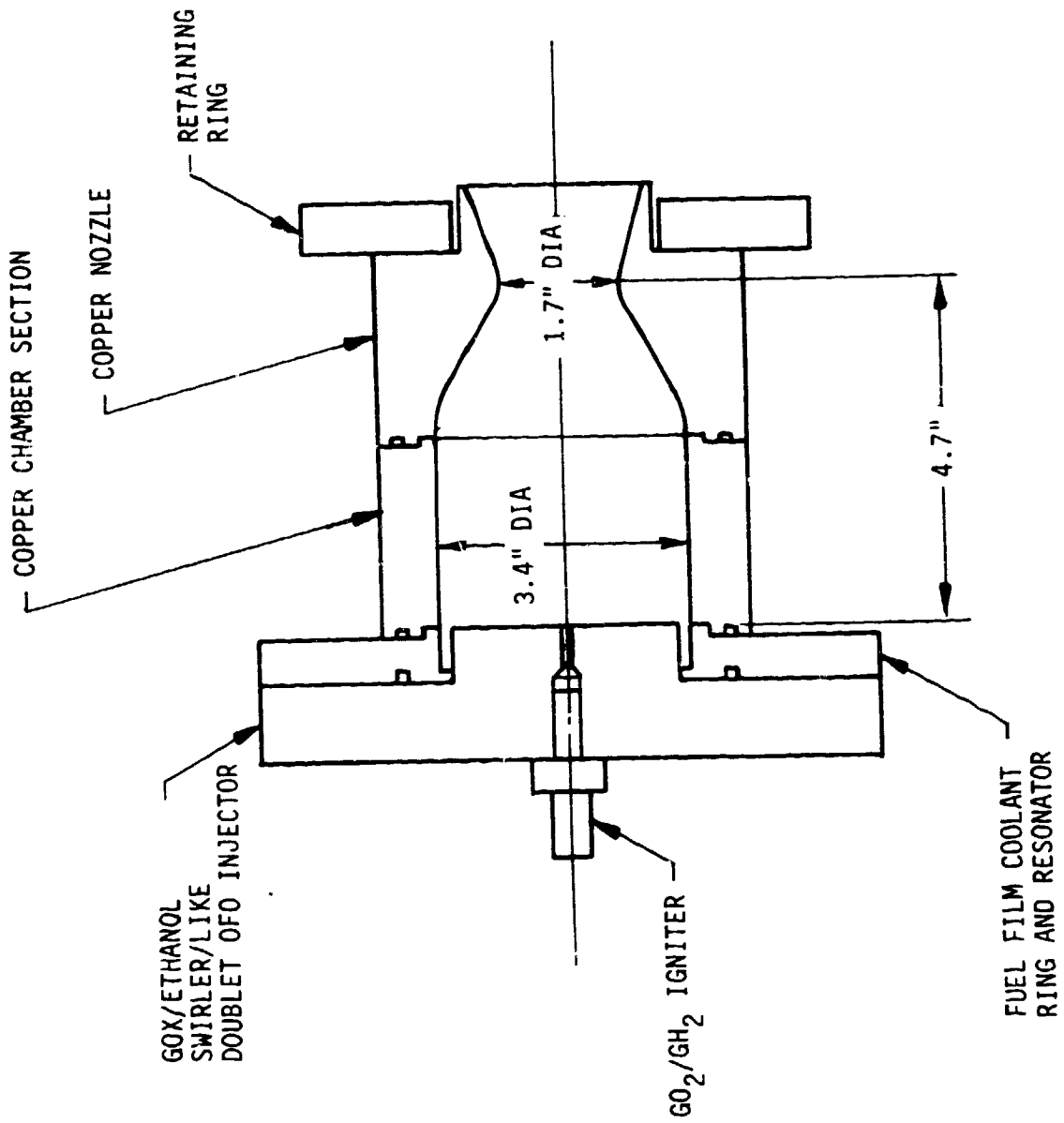

Figure 14. Added Scope Thruster Test Assembly

ORIGINAL PICTURE
OF POOR QUALITY

C1181 143

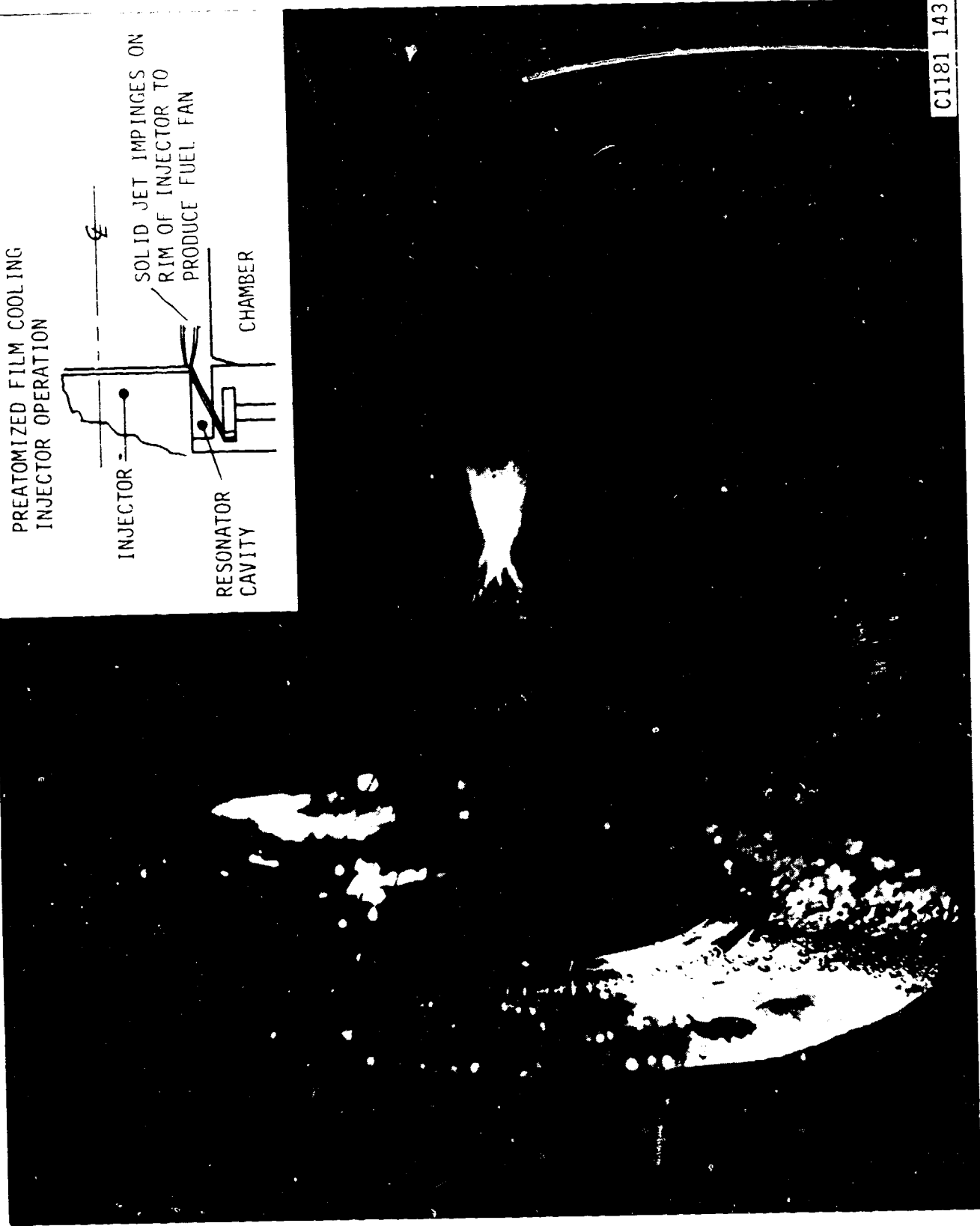

Figure 15. Mid-Pc Fuel Film Coolant Ring

IV, A, Design, Analysis, and Fabrication (cont.)

The injector, shown in Figure 16 consists of a concentric ring manifold with a platelet faceplate. The injector pattern is a 45-element swirler/like-doublet OFO triplet. The pattern layout is shown in Figure 17. The fuel is injected through swirler elements which produce atomized spray cones. The GOX is injected through a set of EDM'd orifices which impinge on the centerline of the fuel spray cone.

Engine ignition was accomplished with an uncooled GO_2/GH_2 igniter. The igniter was operated at a mixture ratio of about 1.2.

3. Thruster Hardware Design and Fabrication

The prototype thruster was designed to acquire GOX /Ethanol ignition and combustion data applicable to an auxiliary propulsion system for the Space Shuttle Orbiter. A 620 lbf thruster that would fit within the existing Space Shuttle RCS engine envelope was selected for testing. Parametric analyses were performed during Task II (Ref. 4) to define the thruster configuration and design criteria as listed in Table IV. The analyses included ignition, performance, cooling and pulse mode operation. The performance analysis optimized the thruster combustion chamber and nozzle lengths for the Space Shuttle envelope. The combustion chamber length (injector face to throat) was optimized at 4 inches and the nozzle length at 7.8 inches with a nozzle expansion ratio of 2/1. A nozzle expansion ratio of 2/1 was selected for sea level testing of the prototype thruster. A nominal chamber pressure of 150 psia was selected on the basis of feed system considerations. A mixture ratio of 1.8 was selected on the basis of the performance and cooling analysis. Twenty five percent (25%) fuel film-cooling was picked.

The fuel manifold dribble volume was chosen to be 0.31 cubic inches, the same as the current Space Shuttle RCS engine. The oxidizer manifold dribble volume was selected to be 4 cubic inches to provide adequate

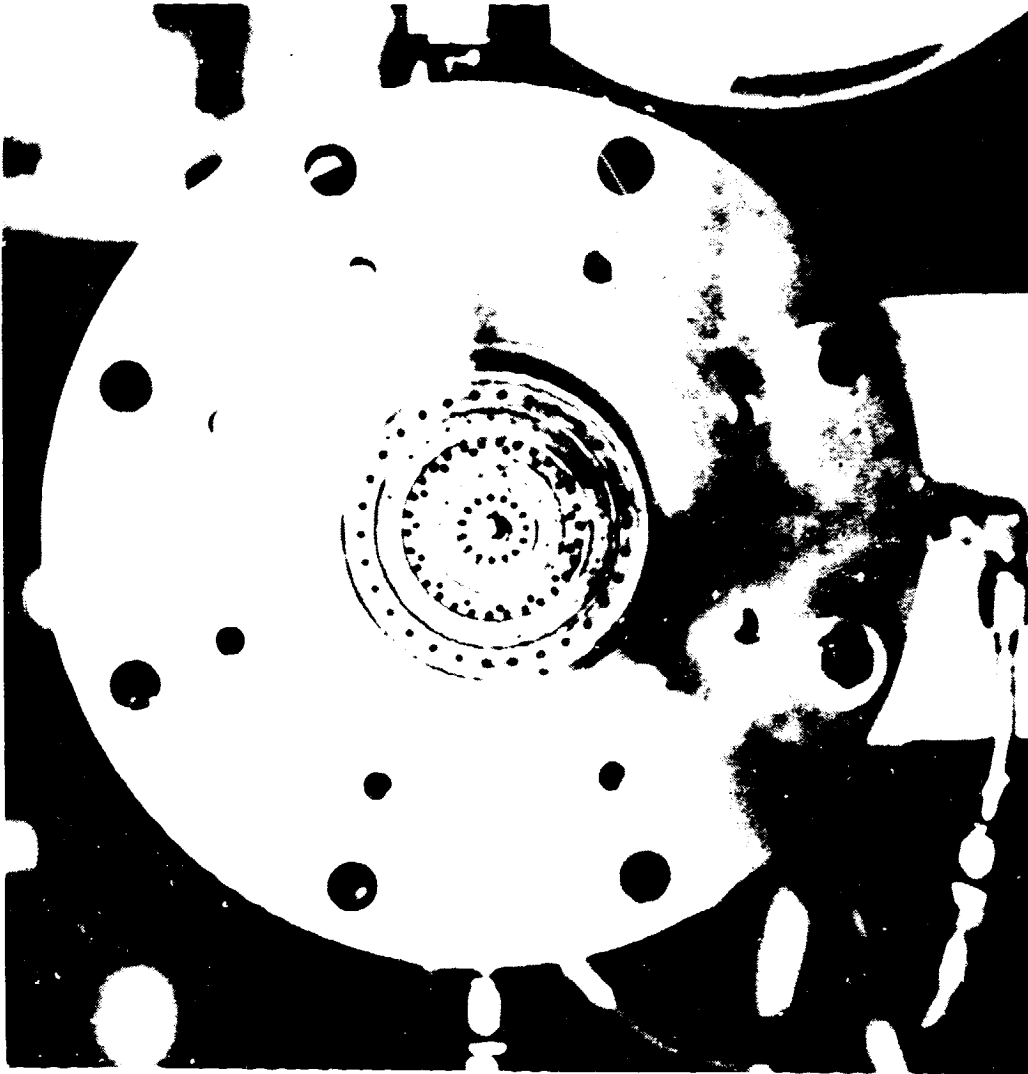

C 1082 056

Figure 16. MID-Pc 60X/Ethanol Swirler/Like Doublet OFO Injector

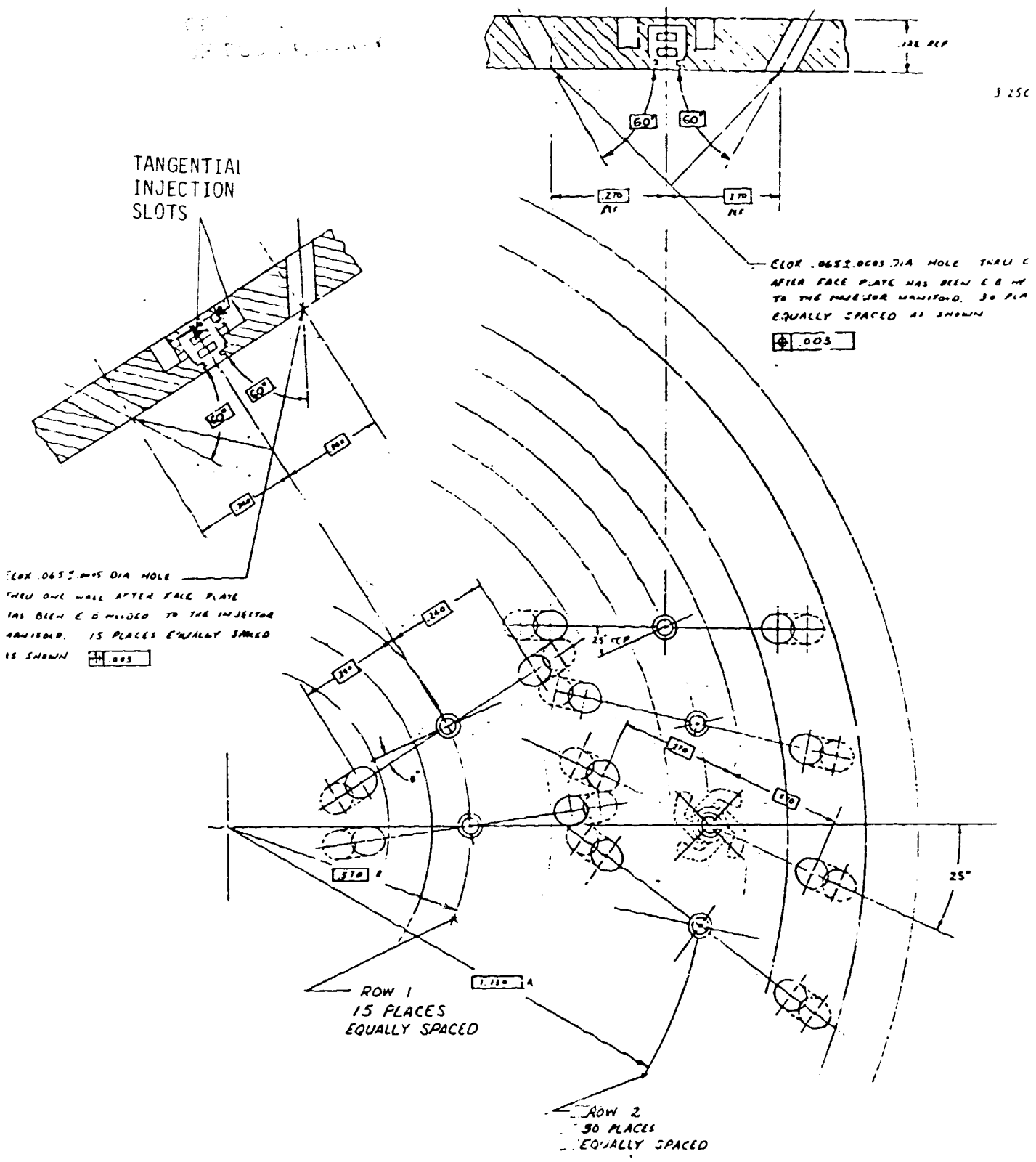

J 25C

PATTERN LAYOUT
SCALE: 10/1

P/N 1195424

Figure 17. Mid-Pc GOX/Ethanol Swirler-Like Doublet OFO Injector Pattern

2

TABLE IV

PROTOTYPE THRUSTER DESIGN CRITERIA

Chamber Pressure	150 psia
Mixture Ratio	1.8
Fuel Film Coolant	25%
Thrust (Vacuum)	620 lbf
Oxidizer Flowrate	1.362 lb/sec
Fuel Flowrate	0.758 lb/sec
Oxidizer Injector Pressure Drop	70 psid (Valve Exit to Face)
Fuel Injector Pressure Drop	152 psia (Valve Exit to Face)
Chamber Length	4 in.
Chamber Diameter	3.4 in.
Throat Diameter	1.7 in.
Contraction Ratio	4/1
Nozzle Expansion Ratio	2/1
Fuel Dribble Volume	0.31 in. ³
Ox Dribble Volume	4 in. ³

IV, A, Design, Analysis and Fabrication (cont.)

volume for diffusion of the GOX to achieve uniform flow distribution across the injector face. Pulse mode analysis showed that the gaseous oxygen would fill and evacuate the manifold at near sonic velocity such that the larger oxidizer manifold volume would not limit pulse mode operation. Subsequent testing substantiated the analytical results.

An assembly drawing of the prototype thruster is shown in Figure 18. It includes the components listed in Table V. The injector assembly is shown in Figure 19. It consists of a 304 stainless steel body and a 347 stainless steel platelet face plate. The fuel injector flow circuit is photo-etched into thin sheets which are diffusion-bonded to form the face plate. The face plate is electron beam (EB) welded to the body. The oxidizer orifices are electro-discharge machined (EDM) into the face plate after EB welding. The fuel film coolant orifices are EDM'd into the periphery of the injector. A cutaway through the injector manifolding is shown in Figure 20. The propellant valves are incorporated into the injector body to minimize manifold dribble volume. The propellant valve pintle and seal assemblies are purchased components. The fuel and oxidizer valves are linked together and driven with a single actuator for simultaneous actuation. The gaseous oxygen always fills faster than the liquid ethanol thus assuring an oxidizer lead on start.

The fuel enters the injector at the fuel inlet and flows through the valve into a manifold which distributes it into fifteen (15) 0.060 inch diameter downcorners. These downcorners feed fifteen (15) platelet manifolds which feed the fuel elements and the fuel film-coolant orifices while avoiding the oxidizer orifice locations. Each of the manifolds are "teed" at the end to feed the thirty (30) film-coolant orifices. The fuel manifolds are designed for velocities of 50 ft/sec. The total fuel manifold dribble volume is 0.31 cubic inches as measured from the valve seat to the injector face.

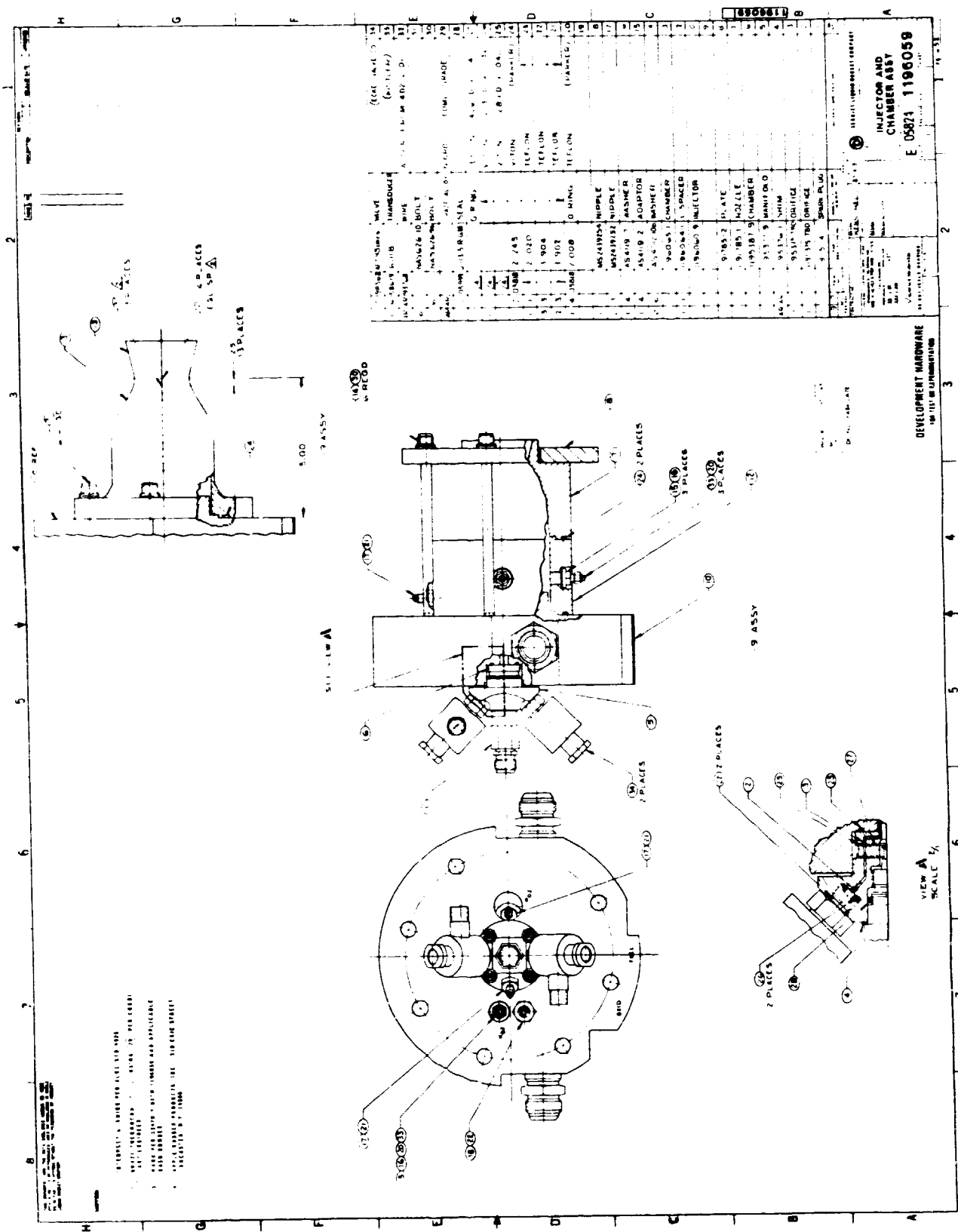

Figure 18. Prototype Thruster Assembly

TABLE V

TASK III HARDWARE LIST

<u>Description</u>	<u>Quantity</u>
Thruster Injector Assembly (with valves)	1
Heat Sink Chamber L' Section	1
Heat Sink Nozzle	1
Chamber Retaining Flange	1
Thin-Wall Chamber	1
Igniter Injector	1
Igniter Chamber	1
Igniter Valves	2
Spark Electrode	2

FOR THE USE OF
OF POOR QUALITY

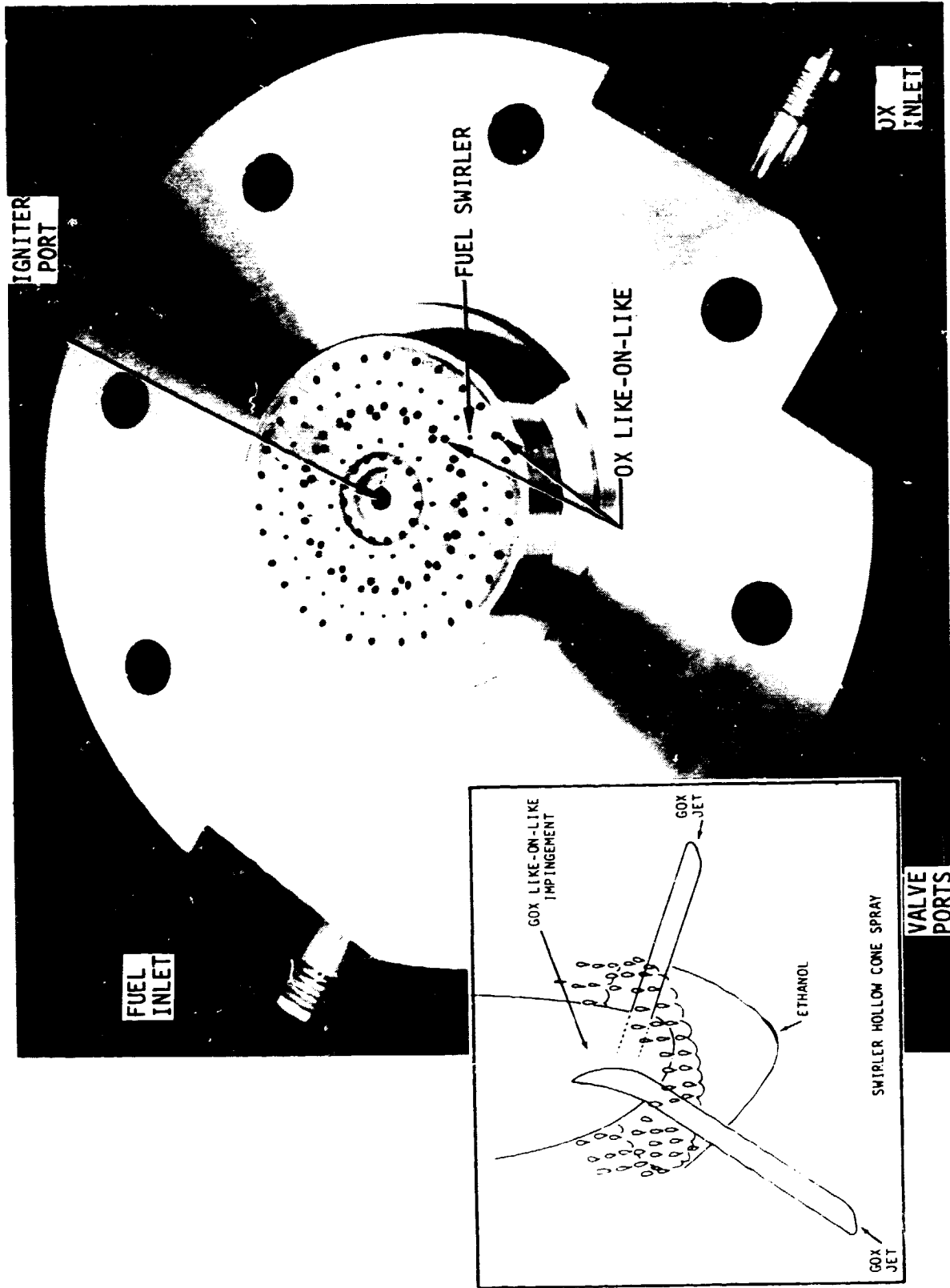

Figure 19. GOX/Ethanol Pulse Thruster Injector

ORIGINAL DESIGN
OF POOR QUALITY

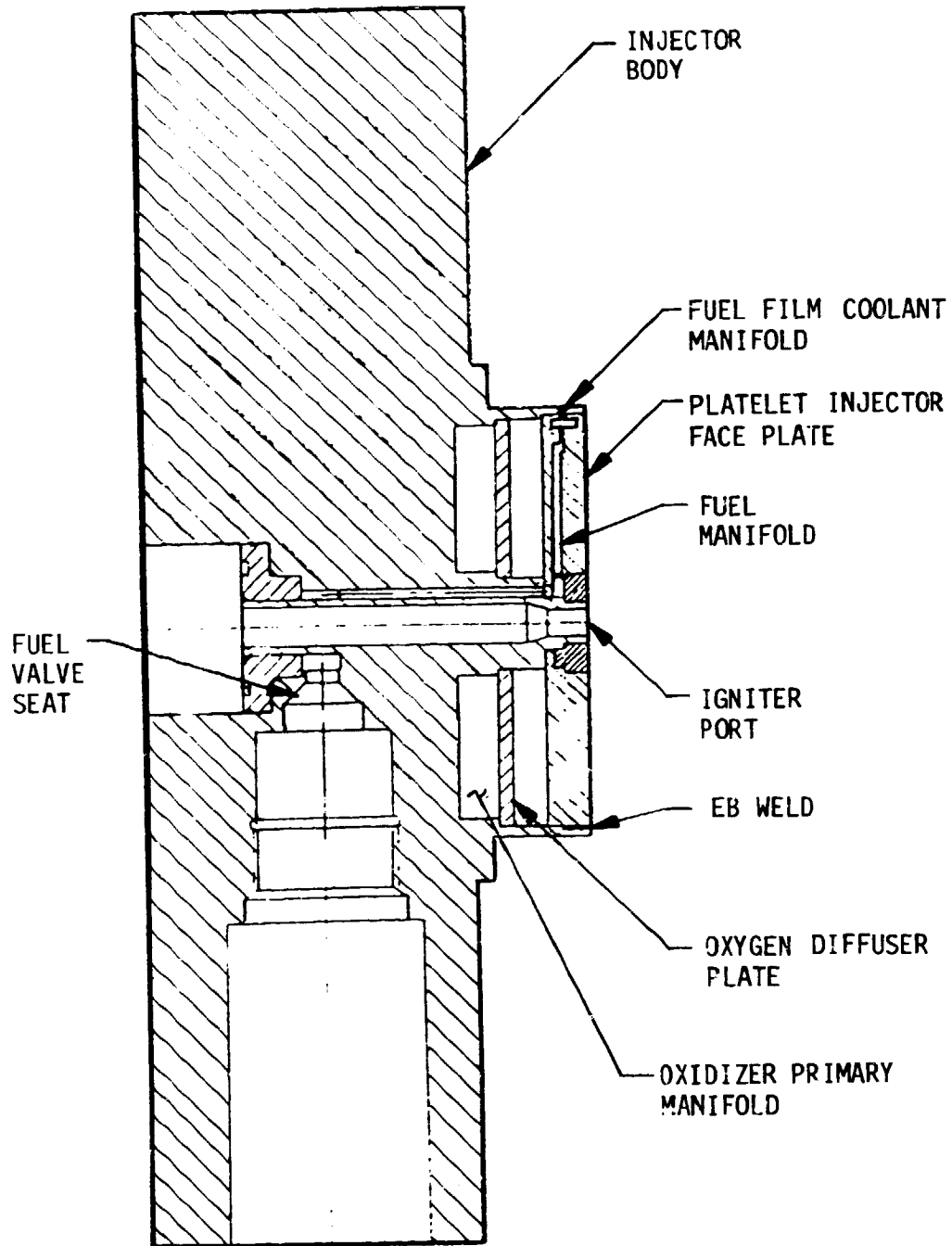

Figure 20. GOX/Ethanol Injector Cutaway

IV, A, Design, Analysis, and Fabrication (cont.)

The oxidizer enters the injector at the oxidizer inlet, flows through the valve and into the primary oxidizer manifold. It flows from the primary manifold through a platelet diffuser having sixteen hundred fifty (1650) 0.025 inch diameter holes into the secondary manifold which feed the injection orifices. The gaseous oxygen manifold volume is approximately 4 cubic inches. The injector pattern consists of forty five (45) fuel swirler elements with like-on-like oxidizer jets impinging over the fuel spray as shown in Figure 21. This pattern is nearly identical to that used on the Mid-Pc program (NAS 9-15958) and the added scope testing. The only difference is that the inner row of oxidizer orifices are injected axially rather than canted due to igniter port interference.

The fuel film-coolant (FFC) was initially injected tangentially from orifices located around the injector periphery as shown in Figure 22. This injection scheme was selected for its simplicity and ease of manufacture. However, early thruster testing revealed throat cooling to be inadequate with this injection scheme. It was subsequently changed to a swirl injection scheme also shown in Figure 22 in an attempt to improve throat cooling. No significant improvement in throat cooling was noted with the swirl FFC. It is recommended that pure axial injection be used in any further film-cooled studies. The platelet fuel film-coolant manifold was designed to be a little larger than necessary to accommodate these kinds of changes by welding and re-machining of the film-coolant orifices.

The injector was cold flow tested prior to initial hot firing to determine the injector admittances and to check the pattern. A photo of the fuel water cold flow at rated fuel flow is shown in Figure 23. The fuel swirler elements produce finely atomized well-defined spray cones as designed. The fuel circuit Kw (admittance) was within 3% of that predicted. The fuel film-coolant orifices produced solid well defined streams. The Kw was within 6% of that predicted. The measured percent film coolant was 25.9% compared to the design goal of 25%.

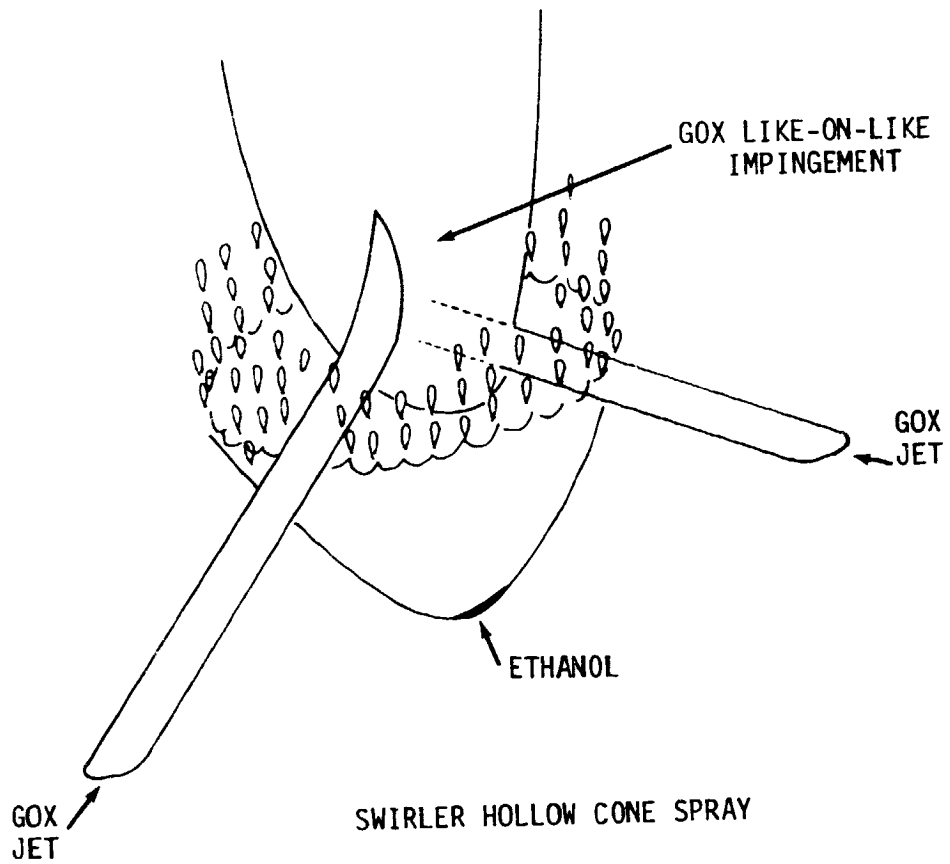

Figure 21. GOX/Ethanol Swirler Like-Doublet OFO Injector Element Concept

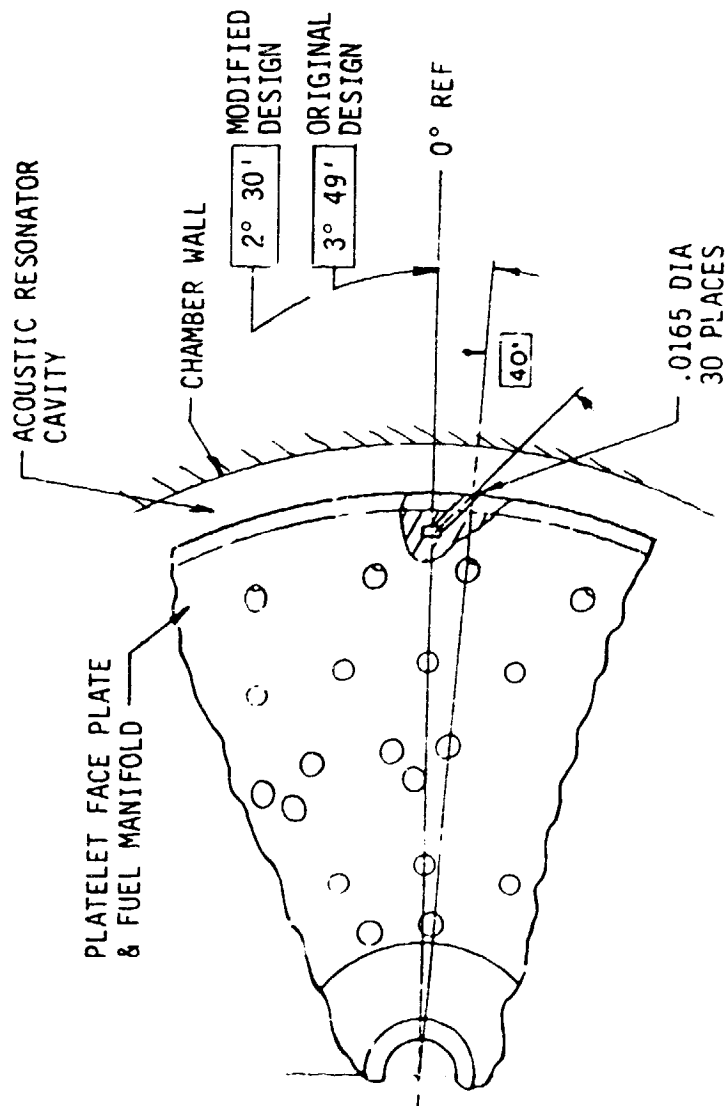
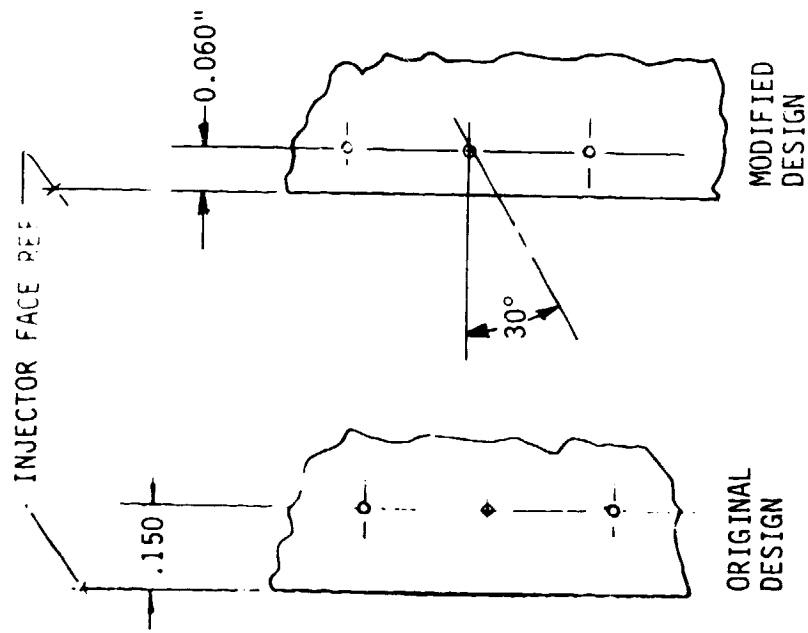

Figure 22. Fuel Film-Coolant Injection Schemes

ORIGINAL PAGE IS
OF POOR QUALITY



Figure 23. Fuel Circuit Cold Flow - Tangential FFC

IV, A, Design, Analysis, and Fabrication (cont.)

The oxidizer circuit was cold flowed with GN_2 . The measured CDA was within 1% of the predicted value.

A copper heat sink chamber L' section was designed and fabricated and is shown in Figure 24. A chamber pressure port and three (3) Kiscler transducer ports were provided. The copper heat sink nozzle section and retainer plate shown in Figure 25 were used with the L' section. They are residual hardware from the Mid-Pc (NAS 9-15958) program.

A 304 stainless steel thin-wall chamber, shown in Figure 26, was designed and fabricated for evaluating the thruster film cooling. It was instrumented with backside wall thermocouples to evaluate wall temperature and film cooling effectiveness.

The igniter assembly was the same hardware used for the Task I igniter testing (Ref. 3). The igniter valves were solenoid actuated and were manufactured by Ekel Valve Corp.

4. Added Scope Igniters

The added scope of this program was to design, fabricate and deliver two igniter injector assemblies to the Johnson Space Center. One of the igniters was to be designed to operate with LOX/liquid propane propellants and the other was to be designed to operate with LOX/liquid methane propellants. These two igniter injectors are similar to the igniter injectors previously designed for operation with gaseous oxygen (GOX) and liquid ethanol propellants.

The operating point conditions of these two propellant combinations are defined by the procedure outlined in the Task II data dump. Analyses were performed to determine core mixture ratio, overall mixture ratio and total propellant flow rate. The final criteria are listed in Table VI.

OF POWER QUALITY



HEAT-SINK CHAMBER SECTION

Figure 24. Copper Heat Sink Chamber Section

CIRCUIT BOARD
OF POOR QUALITY

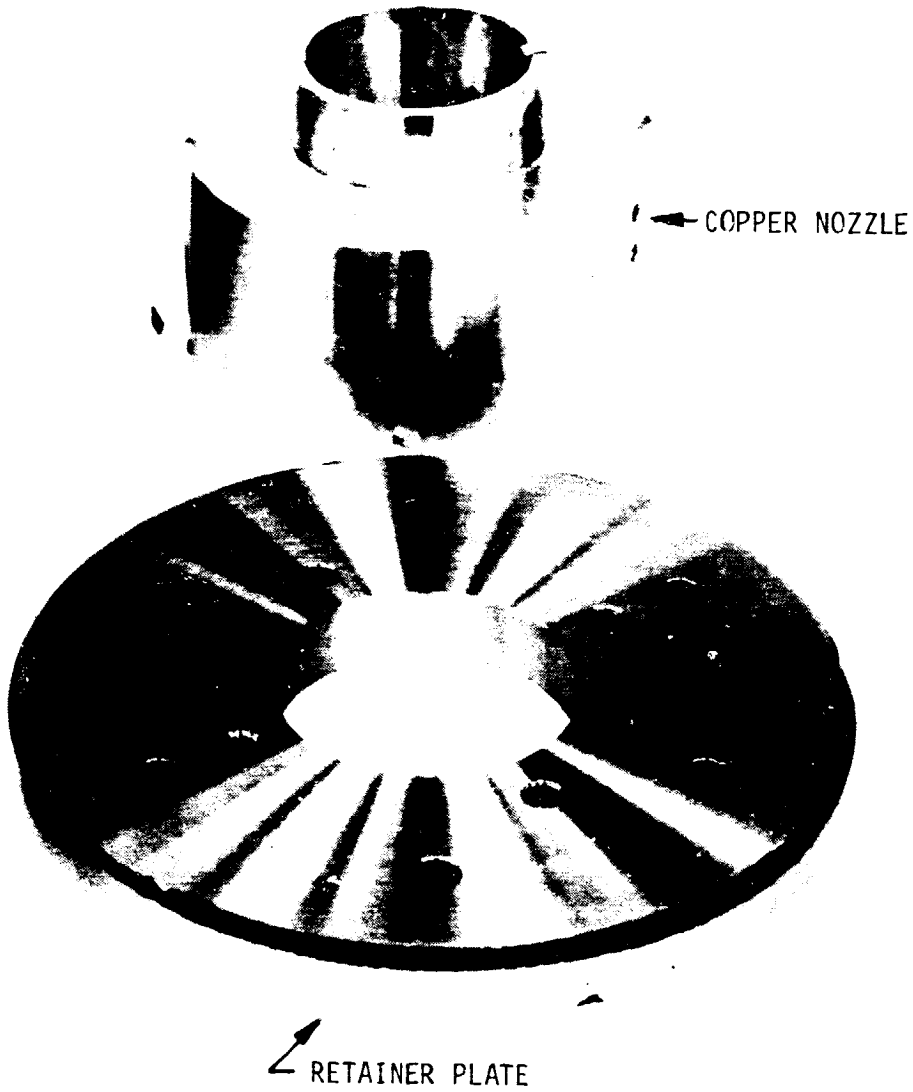

Figure 25. Mid-Pc Heat Sink Nozzle

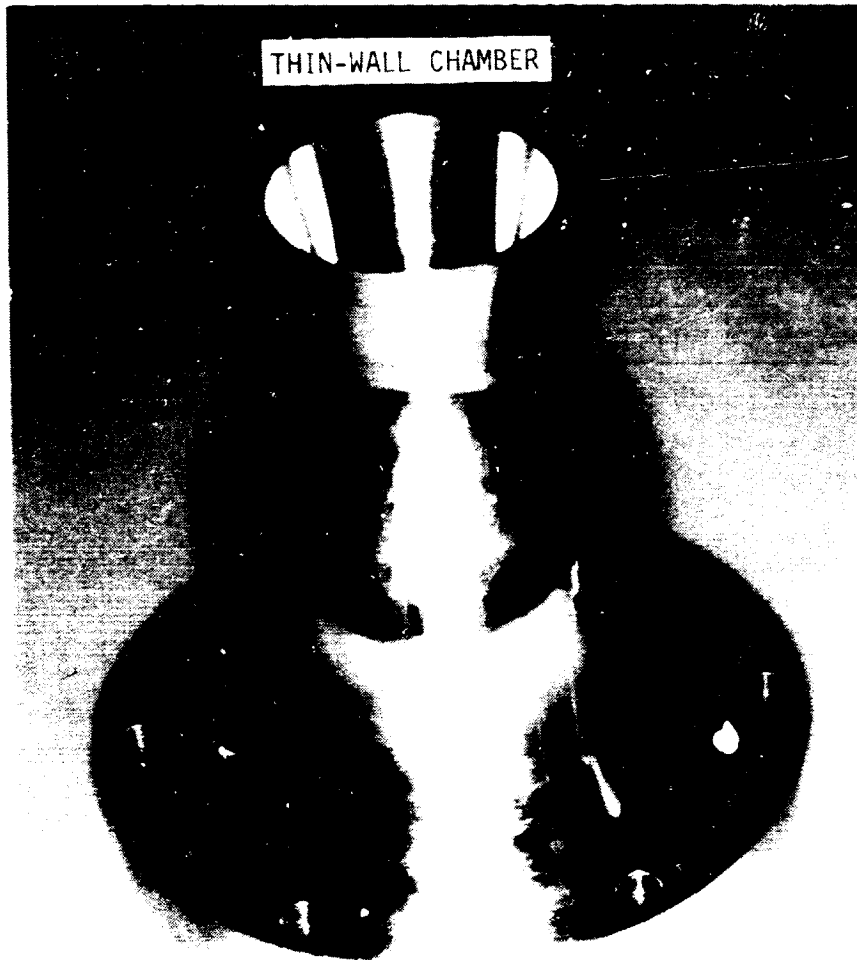

Figure 26. Thruster Thin-Wall Chamber

TABLE VI
SUMMARY OF PREDICTED IGNITER CHARACTERISTICS

	LOX/Propane		LOX/Methane	
	Ox	F	Ox	F
Igniter Kw	0.001748	0.0002413	0.001748	0.000243
Hot Fire				
P_c (psia)	150		150	
$MR_{overall}$	1.6		1.8	
C^*_{ODC} ft/sec	5333		5631	
% Fuel Coolant	90%		90%	
C^* Efficiency	85%		85%	
D_{th}	0.2		0.2	
\dot{w} (lbm/sec)	0.02058	0.001286 (core)	0.02036	0.001131 (core)
		0.01158 (coolant)		0.01018 (coolant)
MR_{core}	16		18	
T_j (°F)	-297	70	-297	-260
S.G.	1.15	0.497	1.15	0.425
ΔP_j (psi)	121	57	118	52
P_{jm} (psia)	271	207	268	202
Cold Flow				
P_{jm} (psia)	271	207	268	202
P_c (psia)	23		23	
ΔP_j (psi)	248	184	245	179
\dot{w} (lbm/sec)	0.02952	0.002308	0.02934	0.002105
MR	12.8		13.9	
PD	4.5		4.5	

IV, A, Design, Analysis, and Fabrication (cont.)

The final flow rate vs ΔP plots for liquid propane, liquid methane and liquid oxygen are shown in Figures 27, 28, and 29 respectively. The design point results are plotted in Figures 30 and 31 for propane/LOX and methane/LOX propellants respectively. These results show that for both propellant combinations the same hydraulic passage geometry were chosen with acceptable pressure drop at the selected flow rates. Since the geometry can be used for both propellant combinations the number of platelet changes were minimized. Additionally, the design is similar to the previous ethyl alcohol test series, reducing the number of platelet changes further.

An assembly drawing of the Task I igniter hardware is shown in Figures 32 and 33. Photographs of some of the hardware are shown in Figures 34, 35, and 36.

The igniter injector assembly is shown in Figure 32. It consists of a machined 304 stainless steel body and a photo-etched 347 stainless steel injector platelet similar to the GOX/ethanol igniter. The two parts are joined with a copper furnace braze cycle. The propellant injection passages, shown in Figure 37 are photo-etched into the platelets which are subsequently diffusion bonded to form the injector stack.

The fuel manifold passages are designed for velocities of approximately 12 ft/sec to minimize dribble volumes. The fuel injector dribble volume is $.000588 \text{ in.}^3$.

The fuel flows from the body into the platelet stack and splits into parallel igniter core and secondary injection circuits. The fuel core flow is distributed through two diametrically opposed rectangular orifices. These 5 mil (.005 in.) by 6 mil (.006 in.) orifices are located just downstream of the spark electrode as shown in Figure 37. The fuel coolant flow is distributed to the cooled chamber through the igniter inlet just downstream of the metering manifold (see Figure 37). The fuel coolant passage is blocked for the uncooled chamber ignition testing.

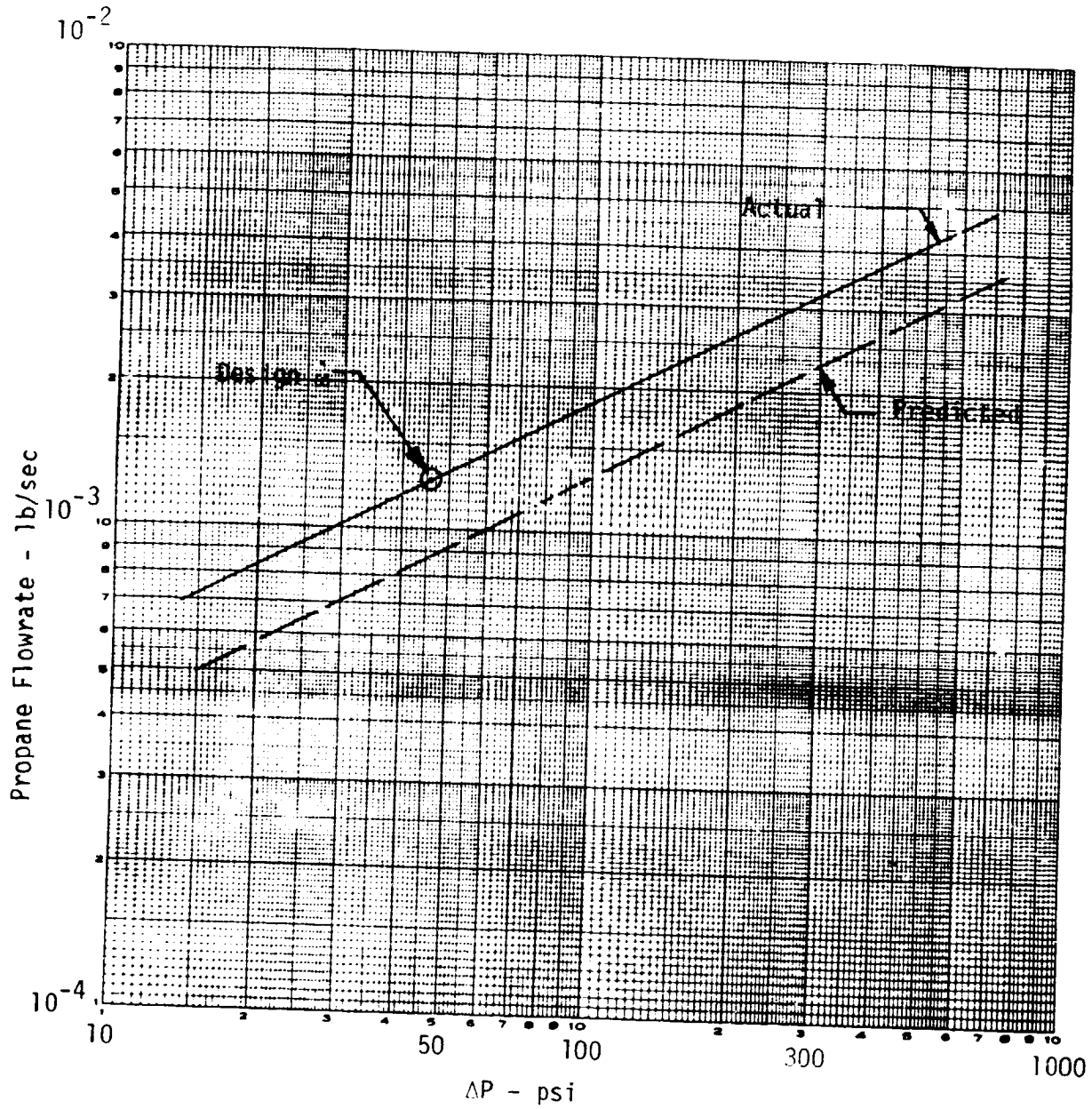

Design Parameter

$\dot{\omega} = .001286 \text{ lb/sec}$

Propane

Fluid Properties

$T_{fu} = -45^{\circ}\text{F}$
 $R_{HG} = 36.5 \text{ lb/ft}^3$
 $Vis = .120 \times 10^{-3} \text{ lbm/ft-sec}$

Channel Size

Width = .005"
 Depth = .006"
 Length = .035"
 2 Platelets
 2 Channels

Figure 27. Propane Flow Rate vs ΔP

OF POOR QUALITY

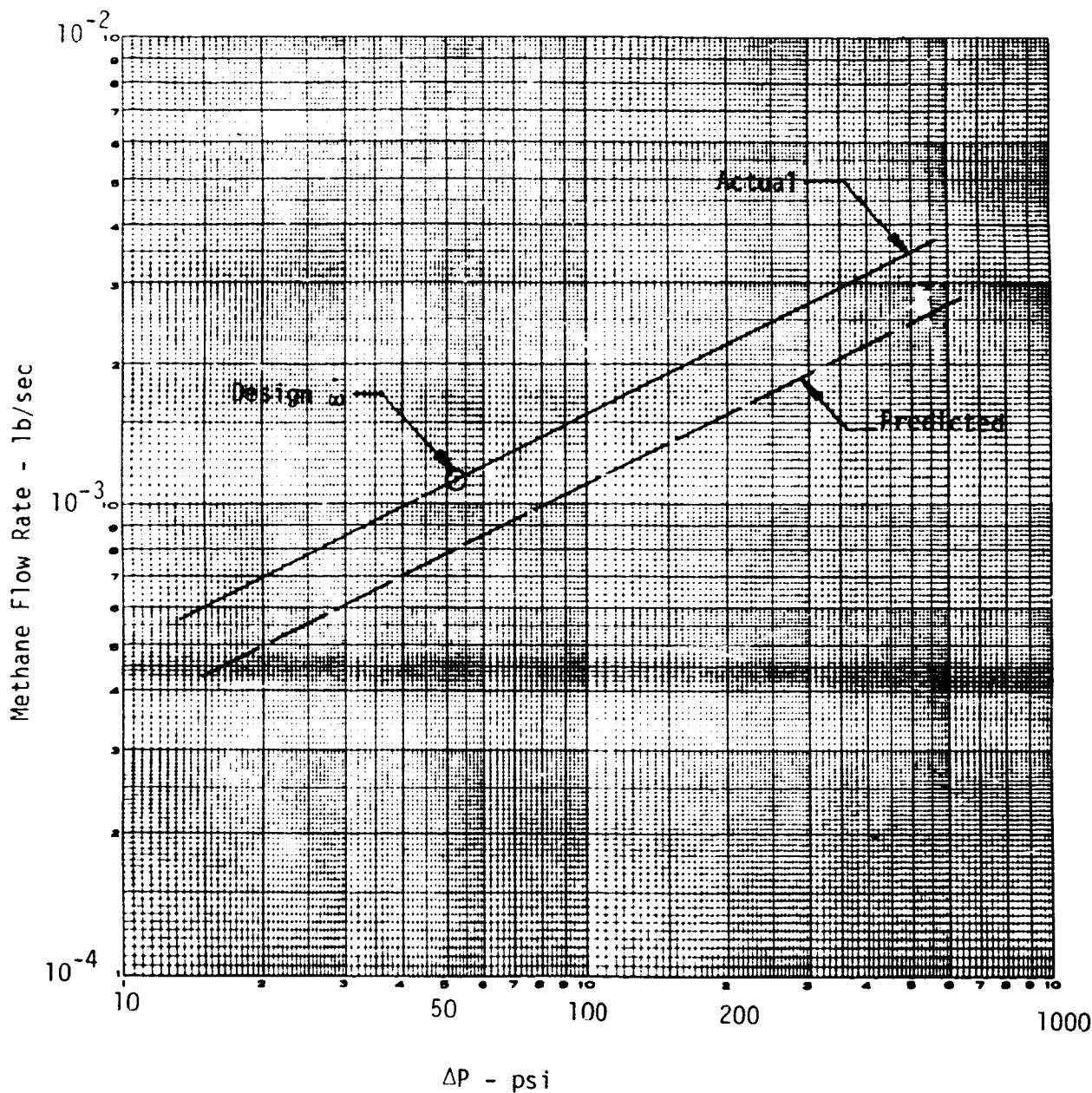

Design Parameter

$\dot{w} = .001131 \text{ lb/sec}$

Methane

Fluid Properties

$T = -250^\circ\text{F}$
 $R_{HO} = 26.5 \text{ lb/ft}^3$
 $Vis = .700 \times 10^{-4} \text{ lbm/ft-sec}$

Channel Size

Width = .005"
 Depth = .006"
 Length = .035"
 2 Platelets
 2 Channels

Figure 28. Methane Flow Rate vs ΔP

OF POOR QUALITY

LOX FLOWRATE VS ΔP

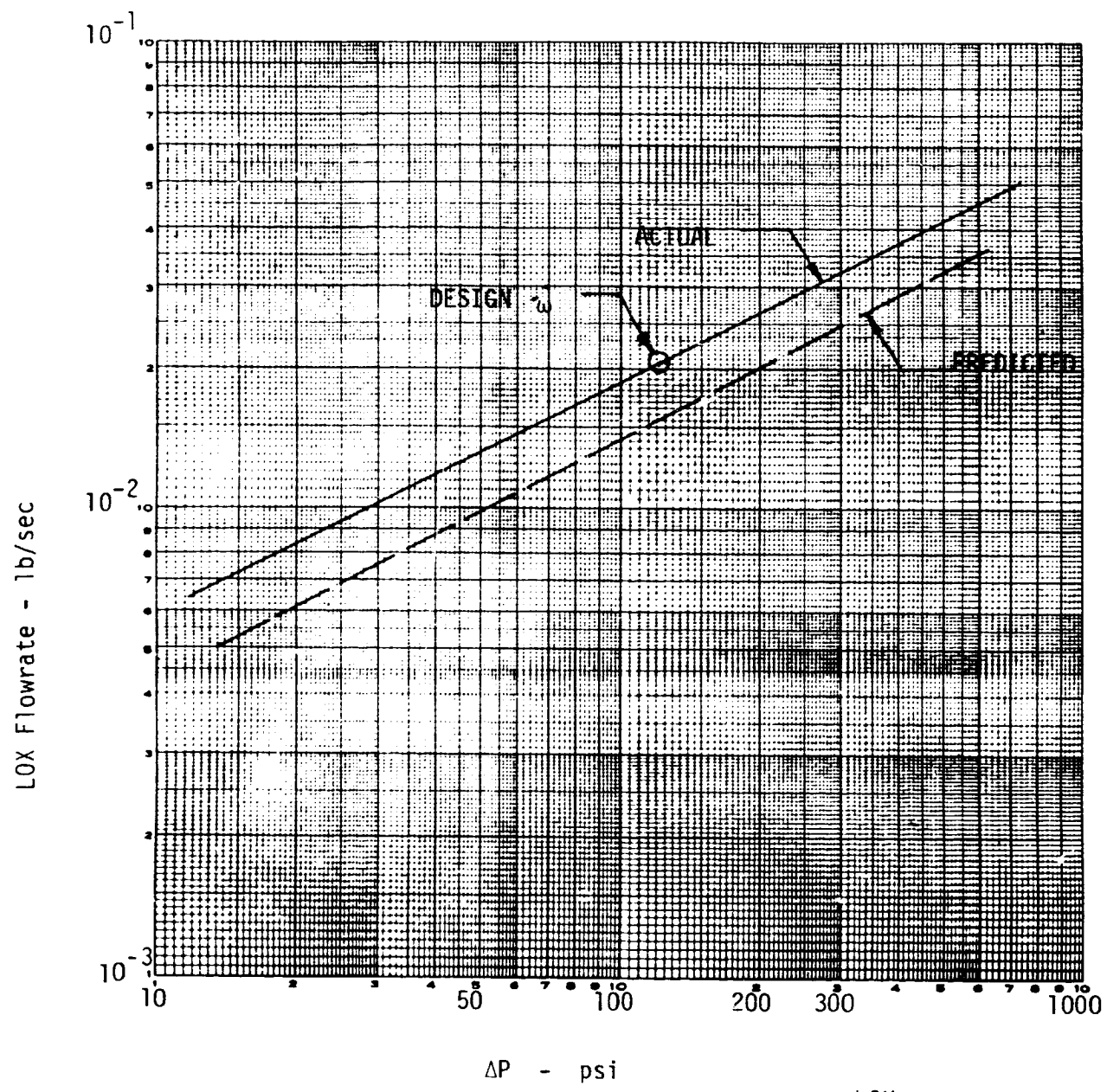

Design Parameter

$\dot{\omega} = .02058$ lb/sec (LOX/Propane)
 $\dot{\omega} = .02036$ lb/sec (LOX/Methane)
 $P_c = 150$ psia

LOX

Fluid Properties

$T_{Ox} = -300^\circ F$
 $R_{HO} = 71.8$ lb/ft³
 $Vis = .135 \times 10^{-3}$
 lbm/ft-sec

Channel Size

Width = .005"
 Depth = .009"
 Length = .170"
 3 Platelets
 12 Channels

Figure 29. LOX Flow Rate vs ΔP

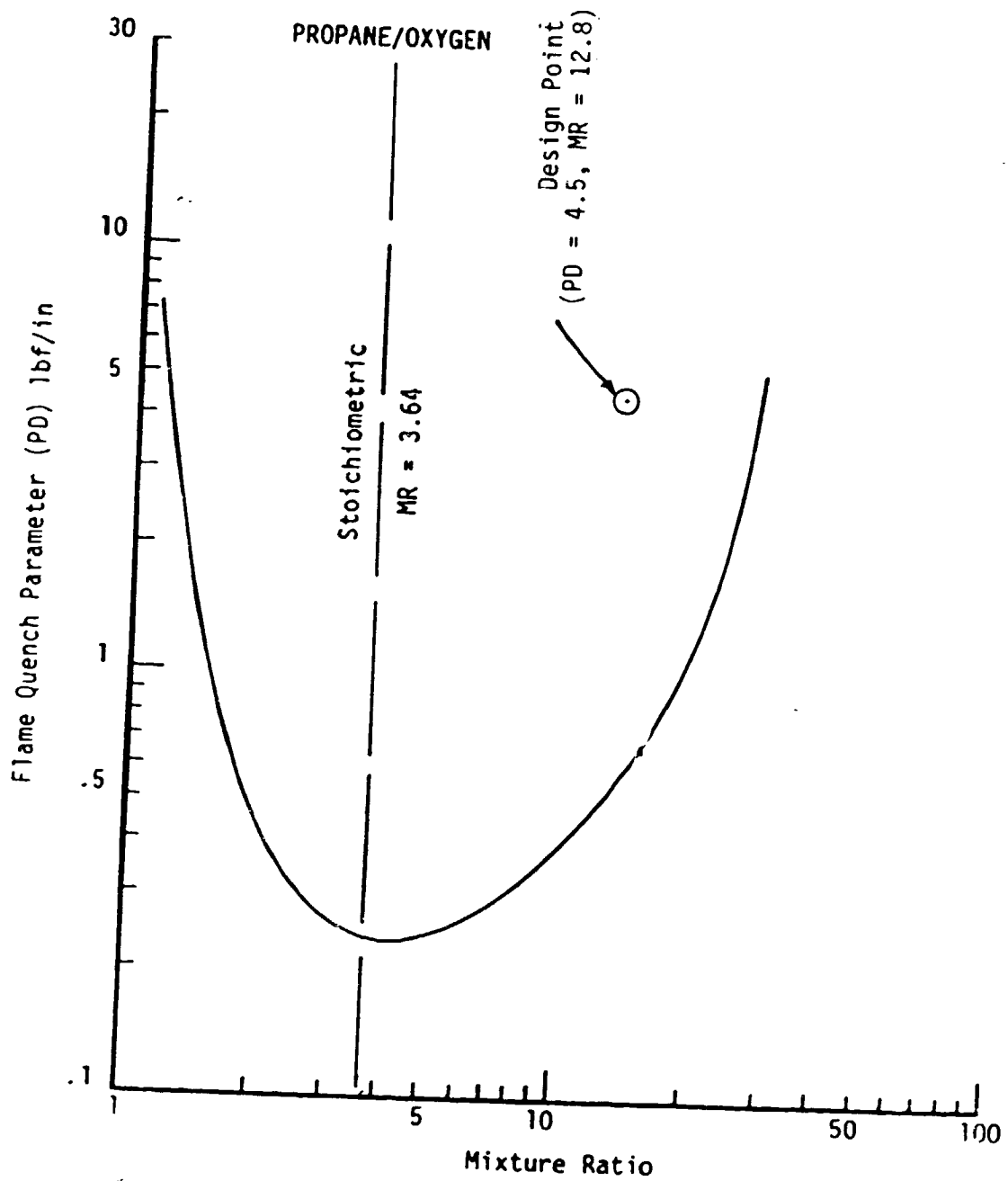

Figure 30. Flame Quench Parameter, Propane/Oxygen

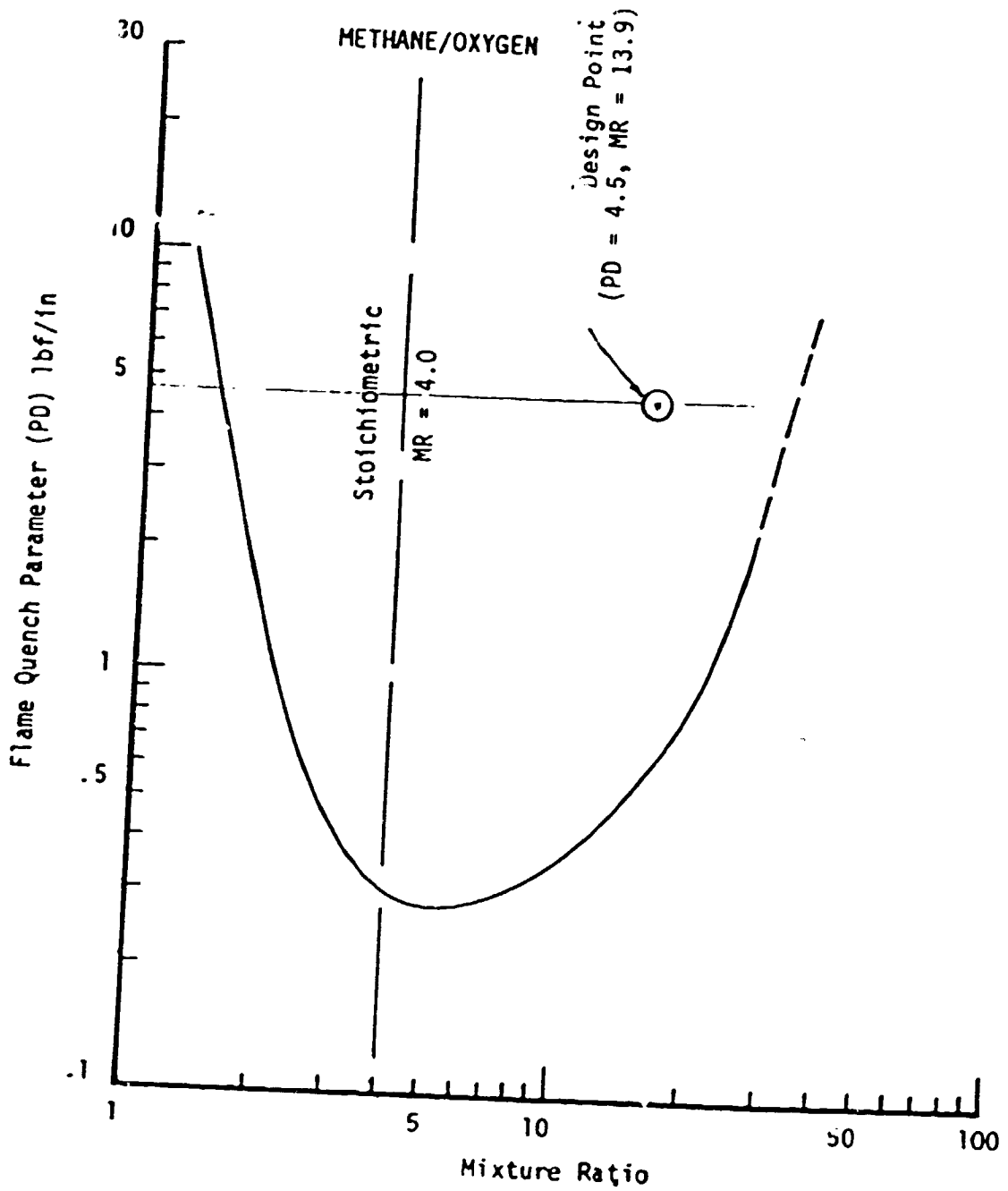

Figure 31. Flame Quench Parameter, Methane/Oxygen

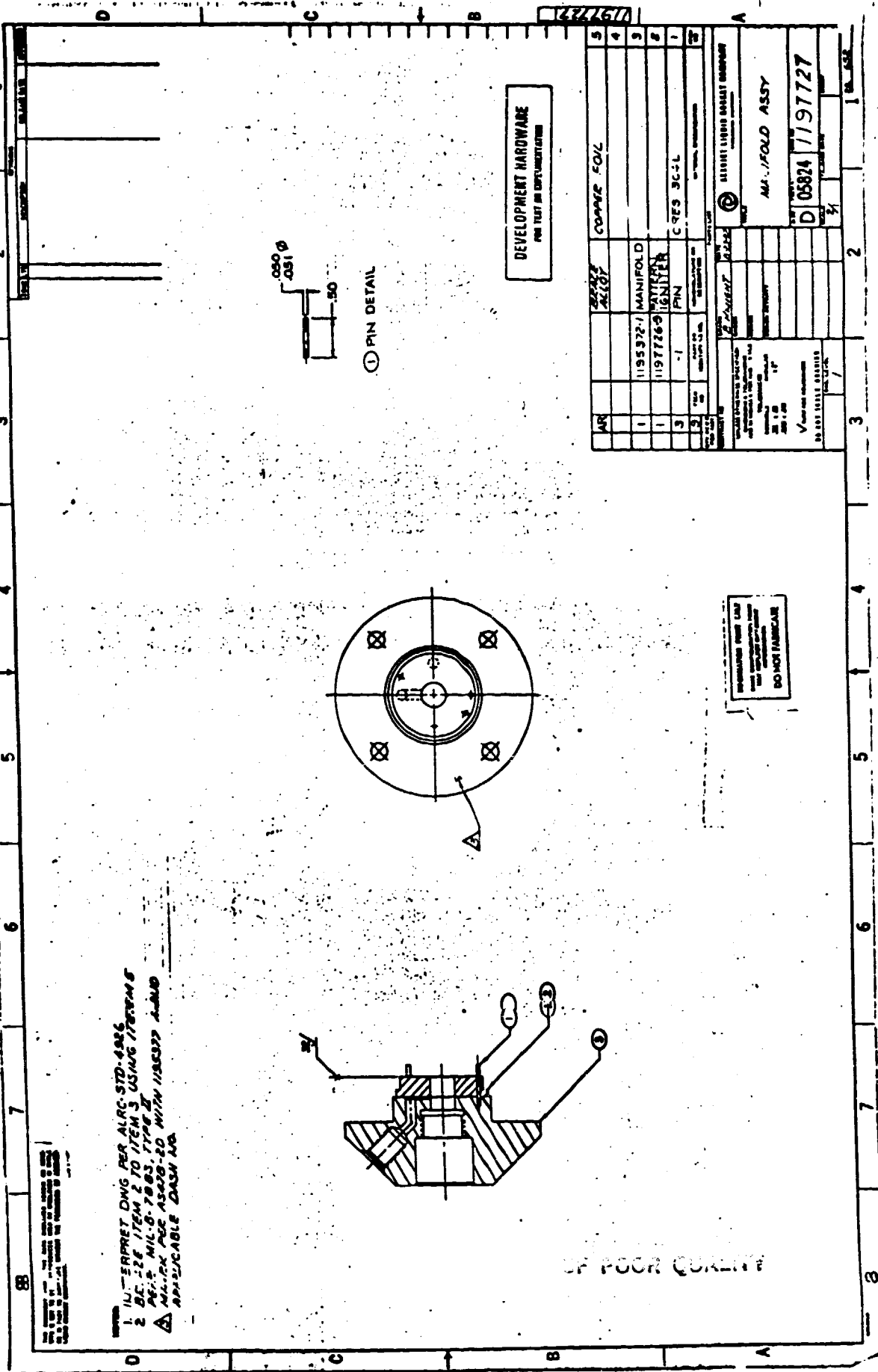

Figure 32. Igniter Manifold Assembly Drawing

DEFENSE DEPARTMENT
OF POOR QUALITY



1 2 3 4 5 6

Figure 34. Completed Igniter Injector Assemblies

ORIGINAL PHOTOGRAPH
OF POOR QUALITY

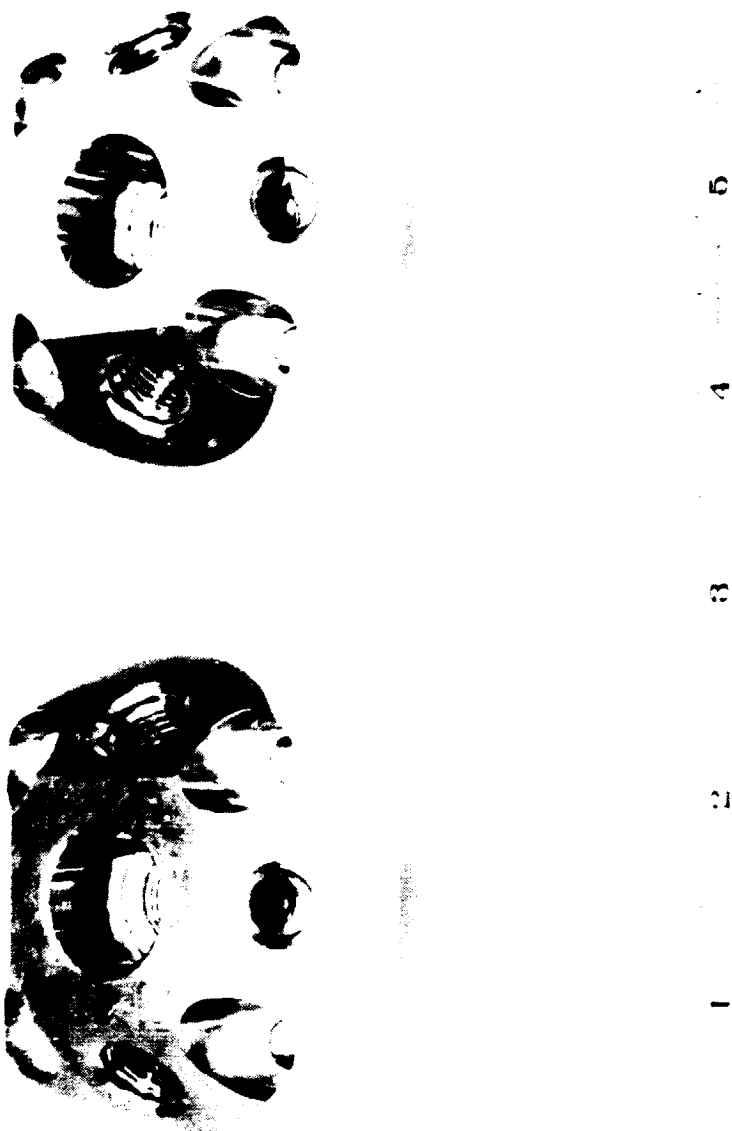

Figure 35. Completed Igniter Manifolds

ORIGIN
OF POLYMER

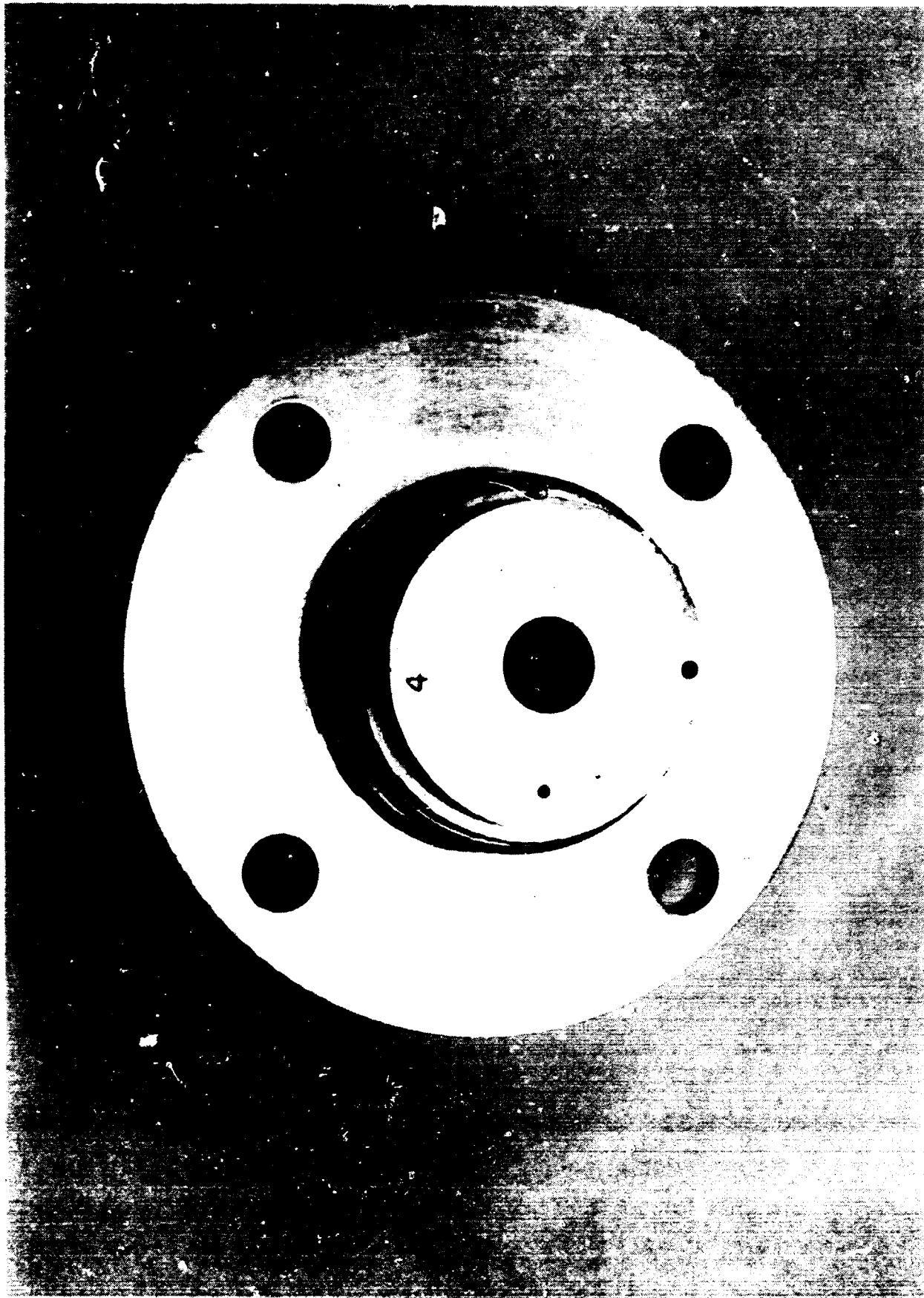

Figure 36. Closeup View of Completed Igniter Injector

ORIGINAL DESIGN
OF POGR QUALITY

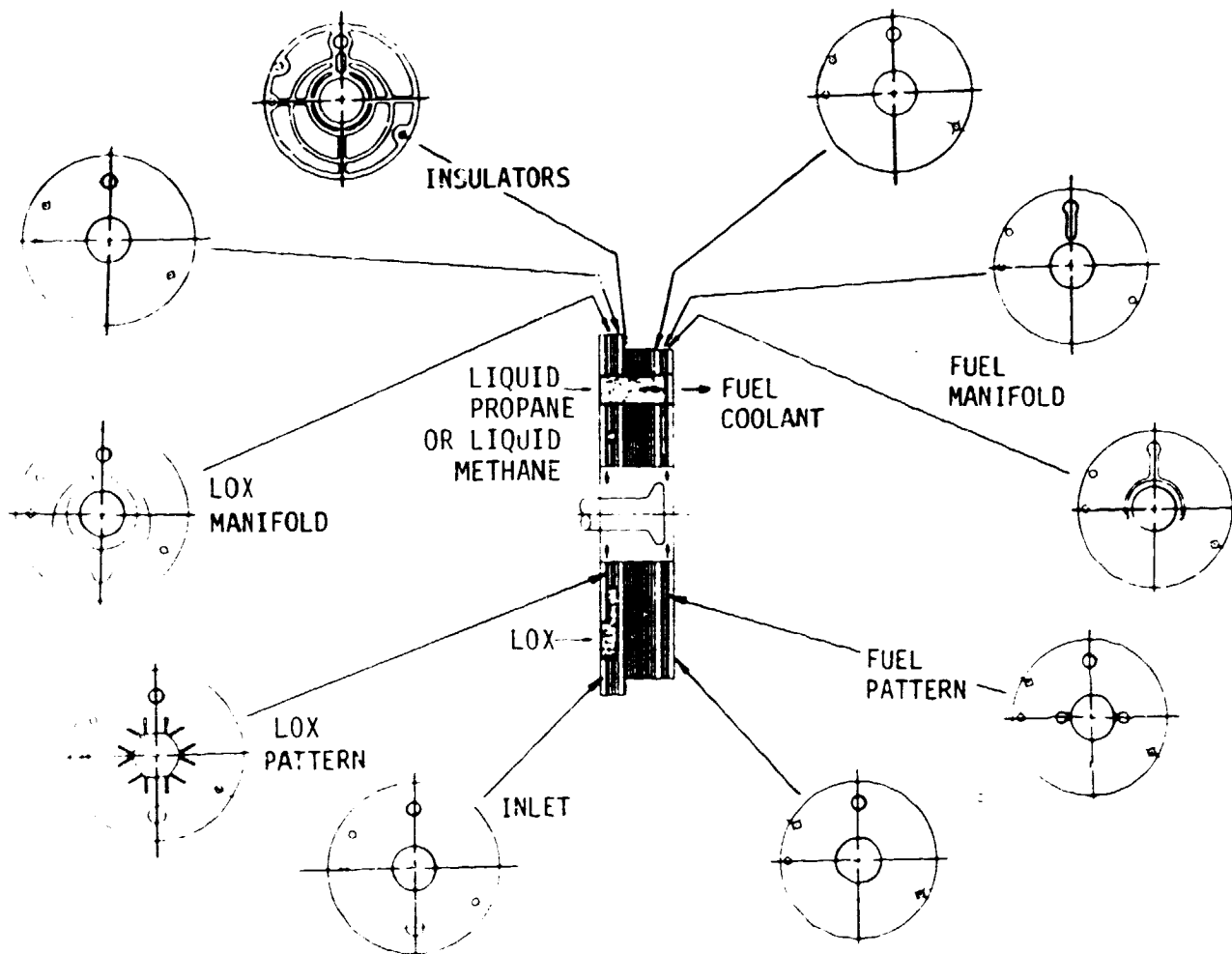

Figure 37. Igniter Injector Flow Schematic

IV, A, Design, Analysis, and Fabrication (cont.)

The LOX enters the platelet stacks from the body and is distributed into the igniter through six pairs of rectangular like-on-like doublet elements. These 5 mil (.005 in.) by 9 mil (.009 in.) orifices are located upstream of the spark electrode as shown in Figure 37. The LOX manifold passages are designed for 5 ft/sec. The LOX dribble volume is .00476 in.³.

The injector flow admittances are listed in Table VII.

B. TESTING

This section of the report discusses testing of the Task I igniter, the added scope injector testing and the Task III thruster testing. Test objectives, test setups and test conditions are described.

1. Igniter Testing

The objectives of the igniter testing were to 1) define the ignition characteristics of spark initiated GOX/Ethanol igniters, 2) determine igniter chamber cooling requirements, 3) evaluate oxidizer manifold fuel contamination potential, 4) evaluate pulse mode operation, and 5) evaluate carbon deposition potential of fuel-rich GOX/Ethanol combustors.

a. Test Setup

Bay 3 of the Rocket Technology Test Laboratory was used for the Task I igniter testing. A flow schematic of the test system is shown in Figure 38. The gaseous oxygen was fed from standard storage "K" bottles. The liquid ethanol was supplied from a nitrogen-pressurized feed system. Both the fuel and oxidizer tanks and all propellant lines were jacketed to provide temperature-conditioning. Temperature conditioning was accomplished by flowing a mixture of liquid and gaseous nitrogen through the tank and line

TABLE VII

IGNITER INJECTOR COLD FLOW RESULTS

$$K_w = \dot{w} \Delta P - \text{lb//sec} - \text{psi}^{1/2}$$

SN 3 Igniter Injector

I. Fuel Circuit Water Flow T = 23°C

ΔP (psi)	\dot{w} (lb/sec)	K_w (lb/sec-psi ^{1/2})
24	.0011	.000225
33	.00136	.000237
46.5	.00160	.000235
62.2	.00193	.000245
76	.00218	.000250
87.5	.00229	.000245
96.5	.00249	.000253
Average		.000241

II. Oxidizer Circuit Water Flow T = 24°C

ΔP (psi)	\dot{w} (lb/sec)	K_w (lb/sec-psi ^{1/2})
54	.01247	.00169
74	.01467	.00170
100	.01768	.00176
119	.01936	.00177
138	.02090	.001779
157	.02211	.001765
Average		.00174

SN 4 Igniter Injector

I. Fuel Circuit Water Flow T = 27°C

ΔP (psi)	\dot{w} (lb/sec)	K_w (lb/sec-psi ^{1/2})
12	.00068	.000196
29	.00112	.000208
39.5	.00132	.000210
45.5	.00138	.000205
53	.00156	.000214
68.5	.00178	.000215
87	.00205	.000220
Average		.000210

TABLE VII (cont.)

II. Oxidizer Circuit Water Flow T = 27°C

ΔP (psi)	\dot{w} (lb/sec)	K_w (lb/sec-psi ^{1/2})
55	.0110	.001483
74.5	.01313	.001521
100	.01555	.001555
120	.01639	.001496
139.5	.01793	.001518
160	.0198	<u>.001565</u>
	Average	.00152

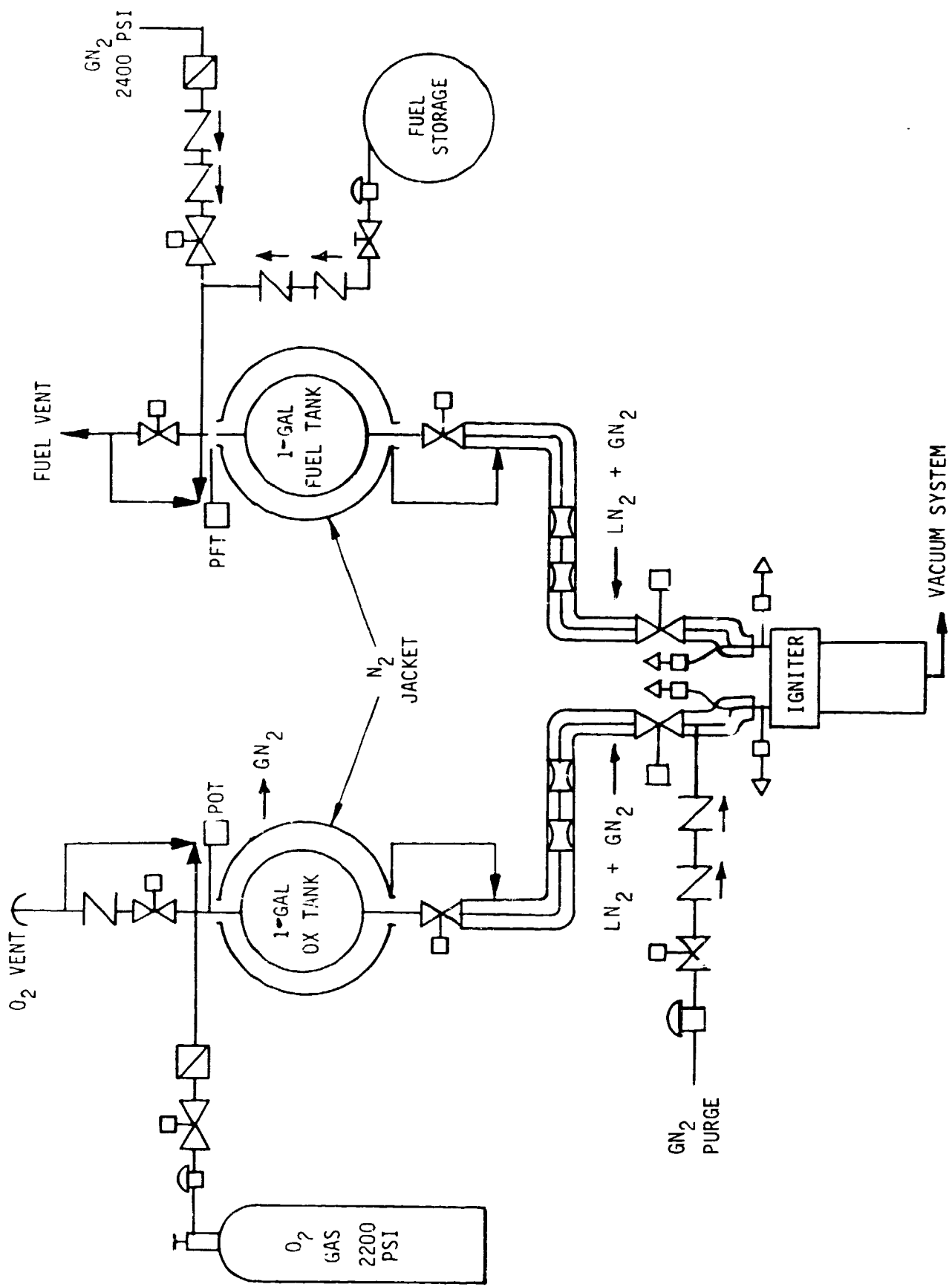

Figure 36. GOX/Ethanol Ignition Test Flow Schematic

IV, B, Testing (cont.)

jackets. The mixture was adjusted to provide temperatures from -100 F to -165 F. The igniter test setup is shown in Figure 39.

The igniter valves are solenoid valves manufactured by Ekel Valve Company. A schematic of the valve is shown in Figure 40. The valve operates on 28 Volt DC power and has a pressure rating of 800 psid.

An Aerojet TechSystems owned variable-energy power supply system (GLA Model 30344) was used to provide spark energy. Power supply specifications are provided in Table VIII. The power supply and spark electrode were manufactured by GLA, a subsidiary of Simmonds Precision.

Instrumentation used for the igniter testing is listed in Table IX. It includes propellant inlet conditions, chamber wall temperatures and chamber ignition parameters. The instrumentation locations are indicated in Figure 41.

The gaseous oxygen (GOX) flowrates were determined using the flow calibrated injector admittance (CD_A) and the measured inlet pressure and temperature. The fuel flowrates for the ignition tests (i.e., core flow only) were determined in a like manner. Turbine flowmeters were used for fuel flow for the long duration cooled chamber tests.

b. Test Conditions and Procedures

The planned test conditions for the GOX/Ethanol ignition and cooling evaluation are listed in Table X. Included are the planned and actual number of tests completed. The igniter testing was conducted in two parts. Part 1 of the testing addressed igniter chamber ignition sensitivity. Two uncooled ignition chambers (0.15 and 0.30 in. in diameter) were used to determine chamber size effects. The cold-flow pressure was varied by controlling the injection inlet pressures and firing into an evacuated chamber.

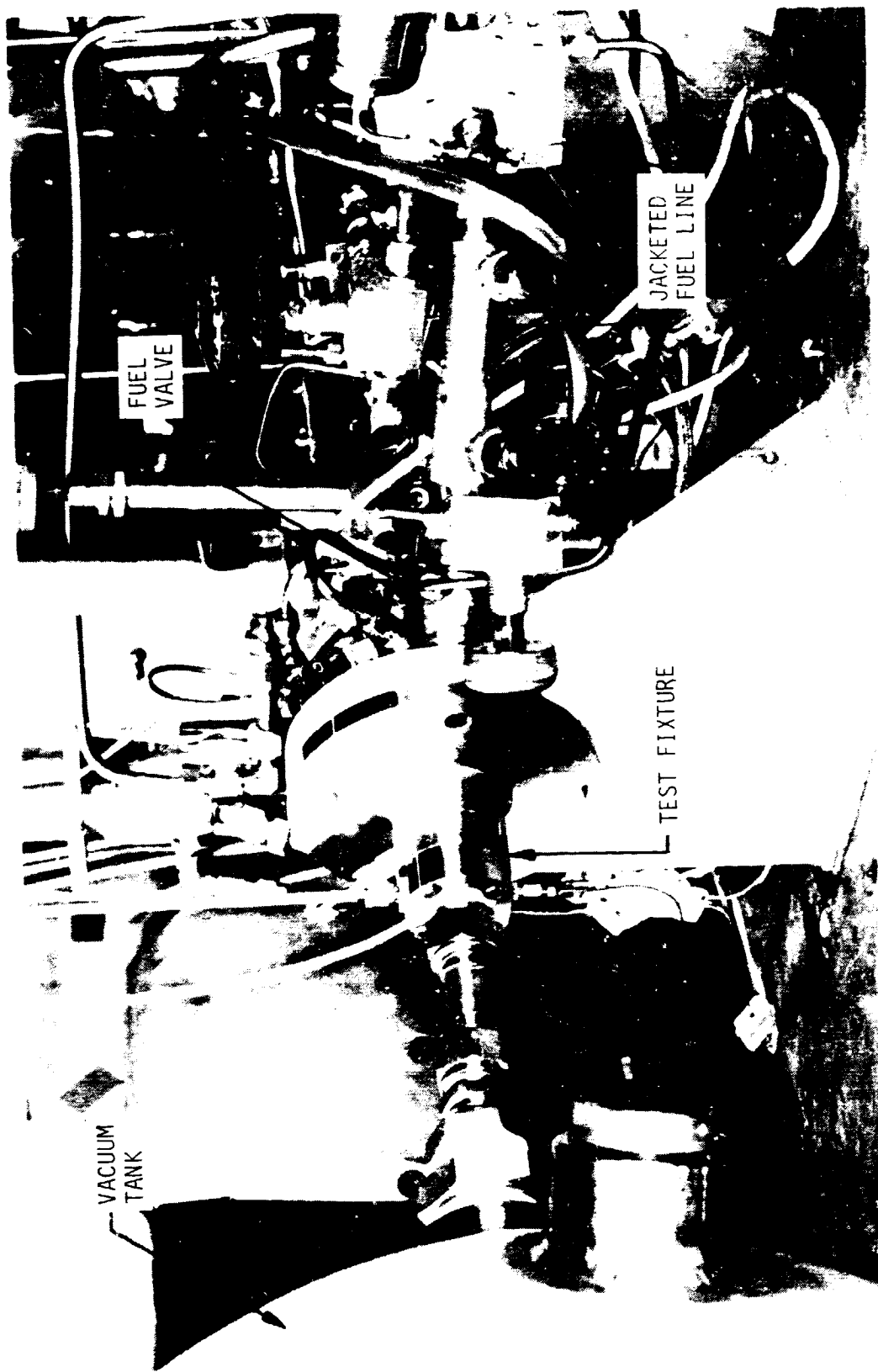
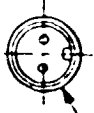
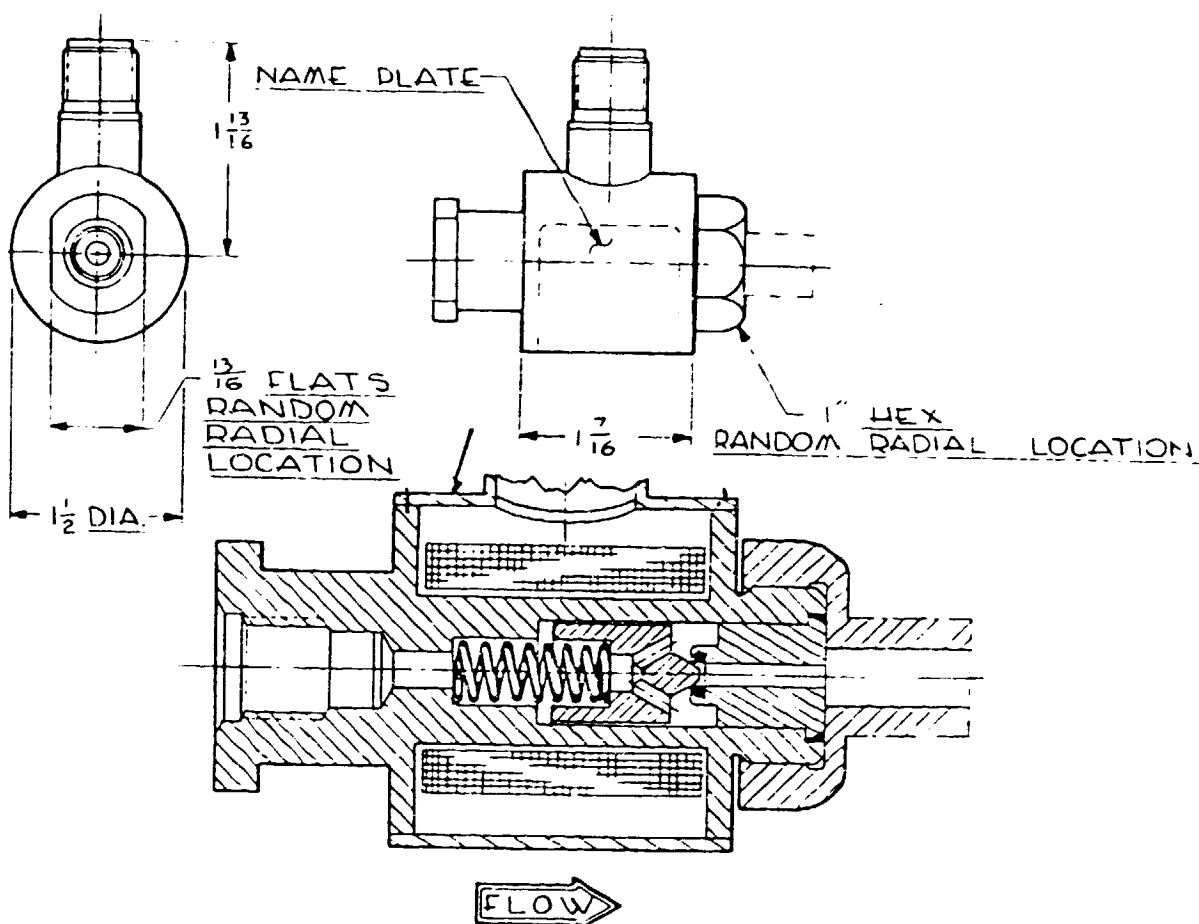
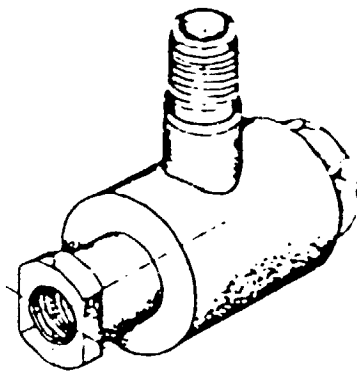

Figure 39. Task I Igniter Test Setup



ELECTRICAL CONNECTOR
PER AND 10066A10SL-4D
(LEADWIRES OPTIONAL)



SCHEMATIC SECTIONAL VIEW

EXCEPT FOR SIZE OTHERWISE SPECIFIED IN WRITING ALL RIGHTS, REPRODUCTION, PATENT & OTHERWISE ARE RESERVED BY ECKEL VALVE CO.	MATERIAL	HEAT TREAT	DRAFTSMAN: J. J. G. 2-C-2000 NOLL PROJ. ENG. G. J. S. APPROVED <i>G. J. S.</i>
	UNLESS OTHERWISE NOTED 1. TOLERANCE PRACTICE IS 1/32" UNLESS OTHERWISE NOTED ANGLE IS 3° (APPLIES ONLY TO ANGULAR ROUNDS) DIMENSIONS HAVE THE 1000:1 RATIO	SPECIFICATION	FINISH
2. CONDUCTIVITY C = 115 C = 115 C = 115 3. DIMENSIONS SHOWN TO THE NEXT LOWER POINT 4. BEVEL OR CHAMFER .003 UNLESS OTHERWISE SPECIFIED OR SHOWN 5. ALL MACHINE SURFACES $\sqrt{32}$ UNLESS OTHERWISE SPECIFIED	VALVE - SOLENOID OPERATED - SHUTOFF		WEIGHT FULL SEE DRAWING NO. .65 LB C AF59 SERIES

Figure 40. Igniter Solenoid Valve Schematic

TABLE VIII

POWER SUPPLY SPECIFICATIONS
GLA MODEL 30344 VARIABLE-ENERGY SYSTEM

1.	Input Voltage	120 volts, 60 Hz
2.	Spark Rate	150, 300, and 500 sparks
*3.	Spark Energy Level	0.01, 0.030 and 0.05 joules
4.	Storage Capacitor Voltage	3500 volts DC (adjustable)
5.	Output Voltage	25-30 kv (will fire 0.100 gap at 35 psig)
6.	Delay Time from Control Input to First Spark	Approximately 0.010 sec
7.	Unidirectional Output Pulse	
8.	Spark Igniter	Air-gap type
9.	Remote Control Capability	(28 VDC)
10.	Peak Reading Voltmeter	
11.	Discharge and Spark Rate Monitor	

*Spark energy levels are based on a storage capacitor voltage of 3400V

TABLE IX

TASK I INSTRUMENTATION LIST

Parameter	Symbol	Units	Range	Recording			
				Digital	O'Graph	FM	Visual
Oxidizer Igniter Valve Current	IOIV	Amps	S/T		X		
Fuel Igniter Valve Current	IFIV	Amps	S/T		X		
Oxidizer Igniter Valve Voltage	VOIV	Volts	0-50		X		
Fuel Igniter Valve Voltage	VFIV	Volts	0-50		X		
Spark Trace	SPK	N/A	N/A		X		
Oxidizer Inlet Pressure	POIV	psia	0-500	X			
Fuel Inlet Pressure	PFIV	psia	0-500	X			
Oxidizer Inlet Temperature	TOIV	°F	-200-100	X			
Fuel Inlet Temperature	TFIV	°F	-200-100	X			
Igniter Chamber Pressure	PCIGN	psia	0-500	X	X		
Test Chamber Pressure	PAMB	psia	0-15	X	X		X
Exhaust Temperature	TEXH	°F	0-2500	X	X		
Wall Temperature	TWALL-1,4	°F	0-2500	X	X		
Injector Temperature	TINJ	°F	-200-100	X			
Fuel Flowrate	WF	lb/sec	0.01-0.02	X			

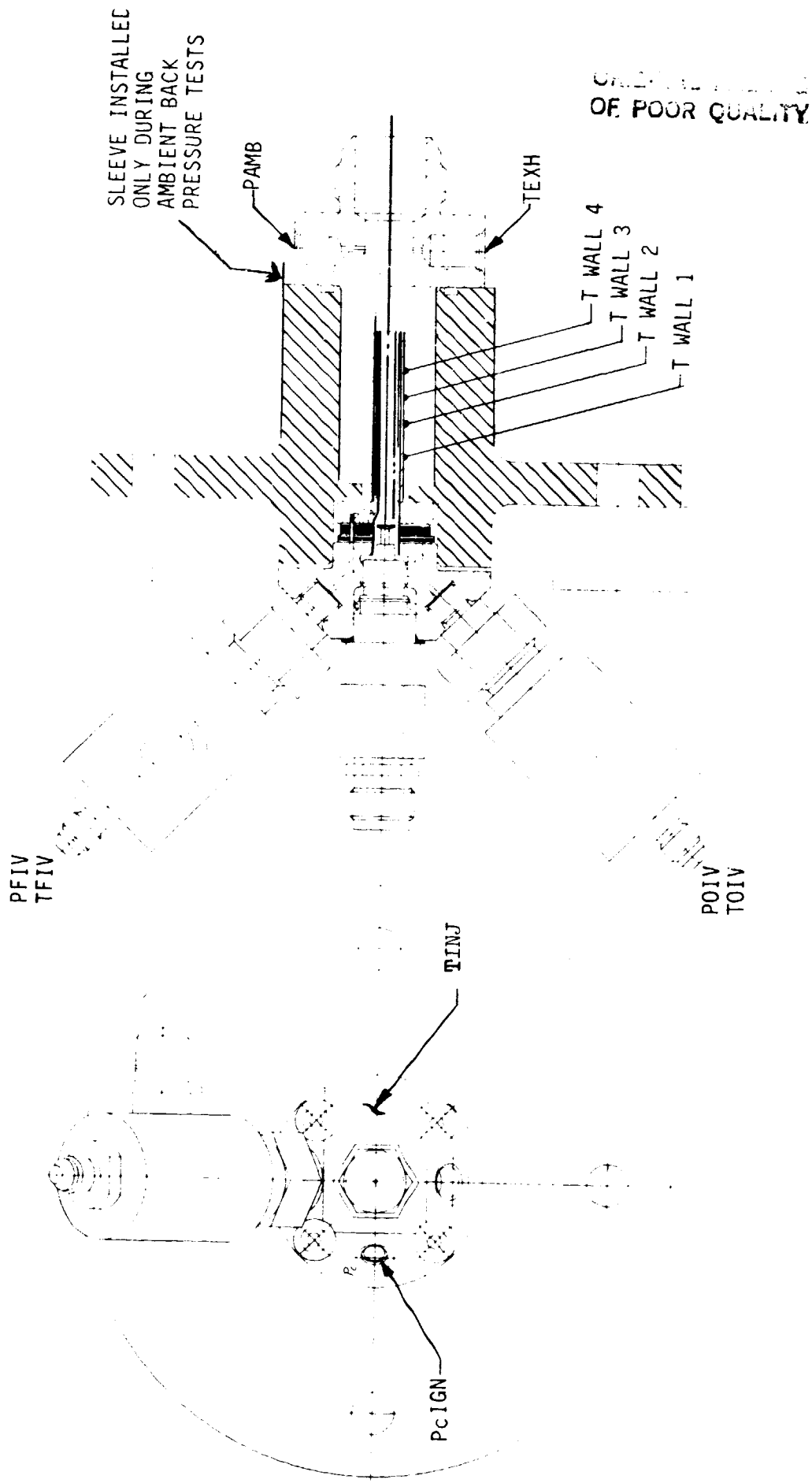

Figure 41. Task I Igniter Instrumentation Locations

TABLE X

TASK I GOX/ETHANOL IGNITION AND DURABILITY TEST MATRIX

Status	Series	# of Tests		Feed/Temp Ox Fuel	Chamber Diameter	Core MP	Film Cooling	Test Conditions		Remarks	
		Actual	Planned					Duration	Chamber Pressure		
Complete	Checkout	A	6	2	Amb/Amb	0-1	TBD	None	0.2	TBD	Checkout
Complete		B	32	25	Amb/Amb	0-1	1-40	None	0.2	1-50	Baseline ignition with ambient propellant
Complete		C	21	4	Amb/Amb	0-1	TBD	None	0.2	TBD	Increased spark at no light conditions
Complete		C-1	4	-	Amb/Amb	0-1	TBD	None	1.0	75-150	Determine heat flux
Complete		D	17	12	Cold/Cold	0-1	TBD	None	0.2	1-50	Ignition with cold propellants
Complete	Ignition Tests	E	4	4	Cold/Cold	0-1	TBD	None	0.2	TBD	Increased spark at no light condition
Complete		F	7	6	Amb/Cold	0-1	TBD	None	0.2	TBD	Cold fuel sensitivity
Complete		G	11	6	Cold/Amb	0-1	TBD	None	0.2	TBD	Cold GOX sensitivity
Complete		H	22	10	Amb/Amb	0-2	1-40	None	0.2	1-50	Reduced dia. sensitivity; ambient propellant
Complete		I	14	10	Cold/Cold	0-2	1-40	None	0.2	1-50	Reduced dia. sensitivity; cold propellant
Complete	Cooling Tests	J	5	2	Amb/Amb	0-4	TBD	TBD	0.2	TBD	Checkout with film cooling
Complete		K	9	6	Amb/Amb	0-4	1-40	None	TBD	1-50	Verify ignition characterization with cooling; ambient propellant
Complete		L	9	6	Cold/Cold	0-4	1-40	None	TBD	1-50	Verify ignition characterization with cooling; cold propellant
Complete		M	6	5	Amb/Amb	0-4	3-20	TBD	5	150	Film cooling effectiveness vs core MR
Complete		N	2	2	Amb/Amb	0-4	3-20	TBD	5	75	Low Pc sensitivity
Complete		O	5	2	Amb/Amb	0-3	TBD	TBD	5	TBD	Low MR coking at gas generator condition
Complete		P	9	5	Cold/Cold	0-4	3-20	TBD	5	150	Film cooling effectiveness at low propellant temperature

TABLE X (cont.)

Status	Series	# of Tests		Feed/Temp/ Dx Fuel	Chamber Diameter	Core MR	Film Cooling	Duration	Chamber Pressure	Remarks
		Actual	Planned							
Complete	Q	4	2	Cold/Cold	D-3	TBD	TBD	5	TBD	Low MR coking at low-temperature gas generator conditions
Complete	R	4	3	Amb/Amb	D-4	TBD	TBD	5	150	Film-cooling optimization
Complete	S	3	3	Cold/Cold	D-4	TBD	TBD	5	150	Film-cooling optimization
Complete	T	3	3	Amb/Amb	D-4	TBD	TBD	0.1	150	Igniter pulse and restart with ambient propellant (? firings per test)
Complete	U	3	3	Amb/Amb	D-4	TBD	TBD	0.1	150	Igniter pulse and multiple restart.
Complete	V	8	3	Cold/Cold	D-4	TBD	TBD	0.1	150	Igniter pulse and restart with cold propellants
Complete	W	10	15	TBD	TBD	TBD	TBD	TBD	TBD	Contingency tests
		216	140							

- NOTE:
1. Adequate altitude conditions maintained through ignition period and through pulse, coast, and restart period.
 2. Chamber pressure refers to cold flow pressure for series A through I and to steady-state pressure for series J through W.
 3. Cold propellant temperatures are approximately 50°F above the fuel freezing temperature.
 4. D-1 = 0.3" diameter;
D-2 = 0.15" diameter;
D-3 = Gas Generator Chamber;
D-4 = 0.2" diameter

IV, 8, Testing (cont.)

Igniter mixture ratio was evaluated over a wide range of 0.4 to 40. The spark energy was varied over a range from 10 to 50 millijoules at a fixed spark rate of 300 sparks per sec to define minimum ignition energy. Approximately 138 ignition tests were made with the uncooled chambers.

Part 2 addressed chamber cooling, low-mixture-ratio (MR) gas generator (GG) operations, pulse-mode operation, and oxidizer manifold contamination in a purgeless operating mode. The igniter chamber coolant flow was controlled independently of core flow to achieve required coolant flow variability. The fuel coolant flow was varied by orificing the fuel inlet to the cooled chamber, see Figure 13. (An orifice was drilled through an alan-head bolt which screwed into the fuel inlet hole shown on Figure 13). Spark energy was held at a constant level as defined by the ignition characterization tests. Long duration (5 seconds) firings were conducted to confirm adequate igniter cooling under steady-state conditions. Approximately 58 cooled chamber tests and 9 gas generator tests were conducted.

The ignition tests were conducted using the sequence shown in Figure 42. The oxygen flow was started 10 msec ahead of the ethanol flow. The spark discharge was delayed about 110 msec to establish the cold-flow pressure. Ignition or non-ignition was indicated by the chamber pressure and exhaust temperature response. The total test duration was 0.4 seconds.

The gaseous oxygen inlet pressure was set to achieve the desired chamber cold-flow pressure and the fuel inlet pressure varied up or down to shift the mixture ratio. The spark energy was varied at fixed inlet conditions to determine its effect on ignition limits.

2. Added Scope Testing

The objective of the added scope testing was to get an early evaluation of GOX/Ethanol auxiliary propulsion thruster performance for 4-inch L¹ chambers, to aide the Task III thruster design. The Task II theoretical

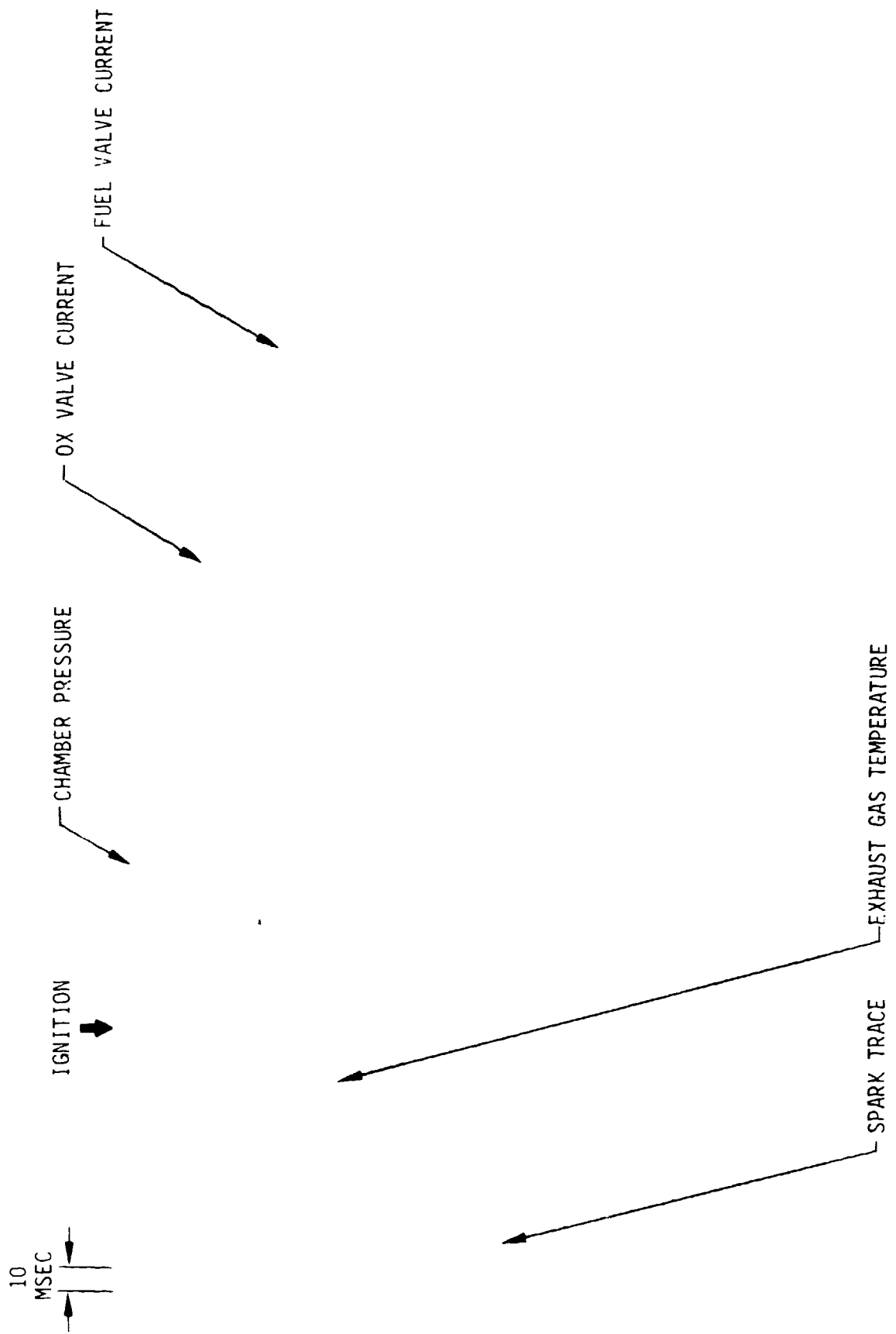

Figure 42. Task I Ignition Test Sequence

IV, B, Testing (ont.)

performance analysis indicated that an RCS thruster chamber length (L') of about 4 inches would provide optimum performance, given the Space Shuttle RCS envelope constraints shown in Figure 43. The parametric analysis examined the effects of overall mixture ratio, propellant temperature, chamber length for a fixed engine length, percent fuel film-coolant, chamber pressure, and nozzle area ratio. A design point mixture ratio of 1.8 was selected to achieve peak performance. A design point chamber length of 4 inches was selected to provide peak I_{sp} for the fixed engine envelope. The intent of the added scope testing was to confirm these predictions.

a. Test Setup

The testing was conducted in the Aerojet TechSystems "A" Area Research Physics Lab Test Bay 6, shown in Figure 44. A complete description of the test facility is given under the Task III thruster test discussion.

b. Test Conditions and Procedures

The planned test matrix is shown in Table XI. Seven tests each with ambient temperature and cold temperature propellants were scheduled to be conducted. Nine (9) ambient temperature and ten (10) cold propellant tests were actually completed. The test matrix was structured to acquire performance data over the chamber pressure and mixture ratio range selected for the Task III thruster: $P_c = 100$ to 300 psia and $MR = 1.3$ to 2.4. The film coolant was varied from 0-20% of the fuel flow.

3. Task III Thruster Testing

The primary objective of the Task III testing was to experimentally evaluate GOX/Ethanol thruster ignition and pulse-mode operation. A secondary objective was to evaluate thruster steady-state performance, fuel

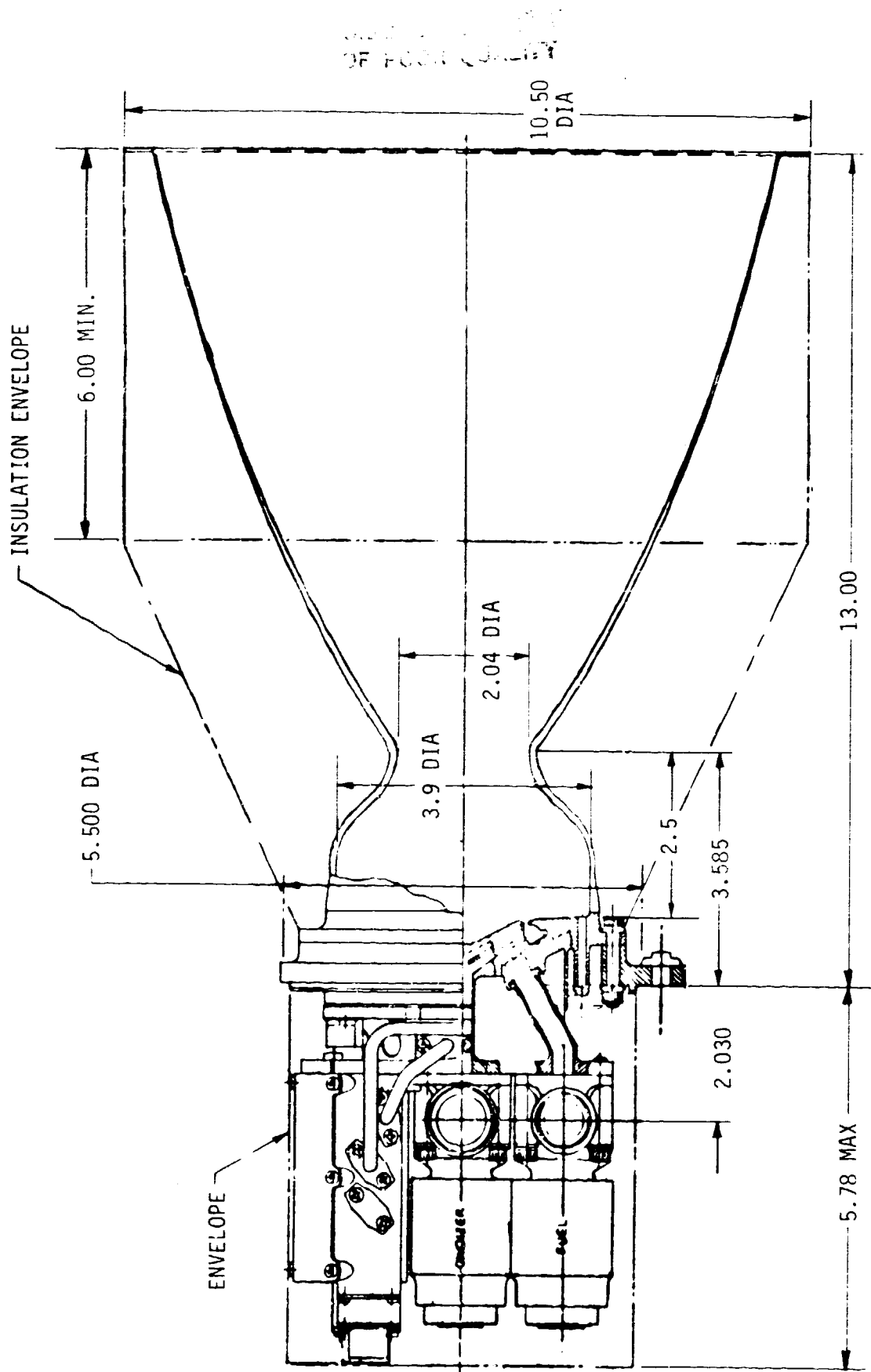
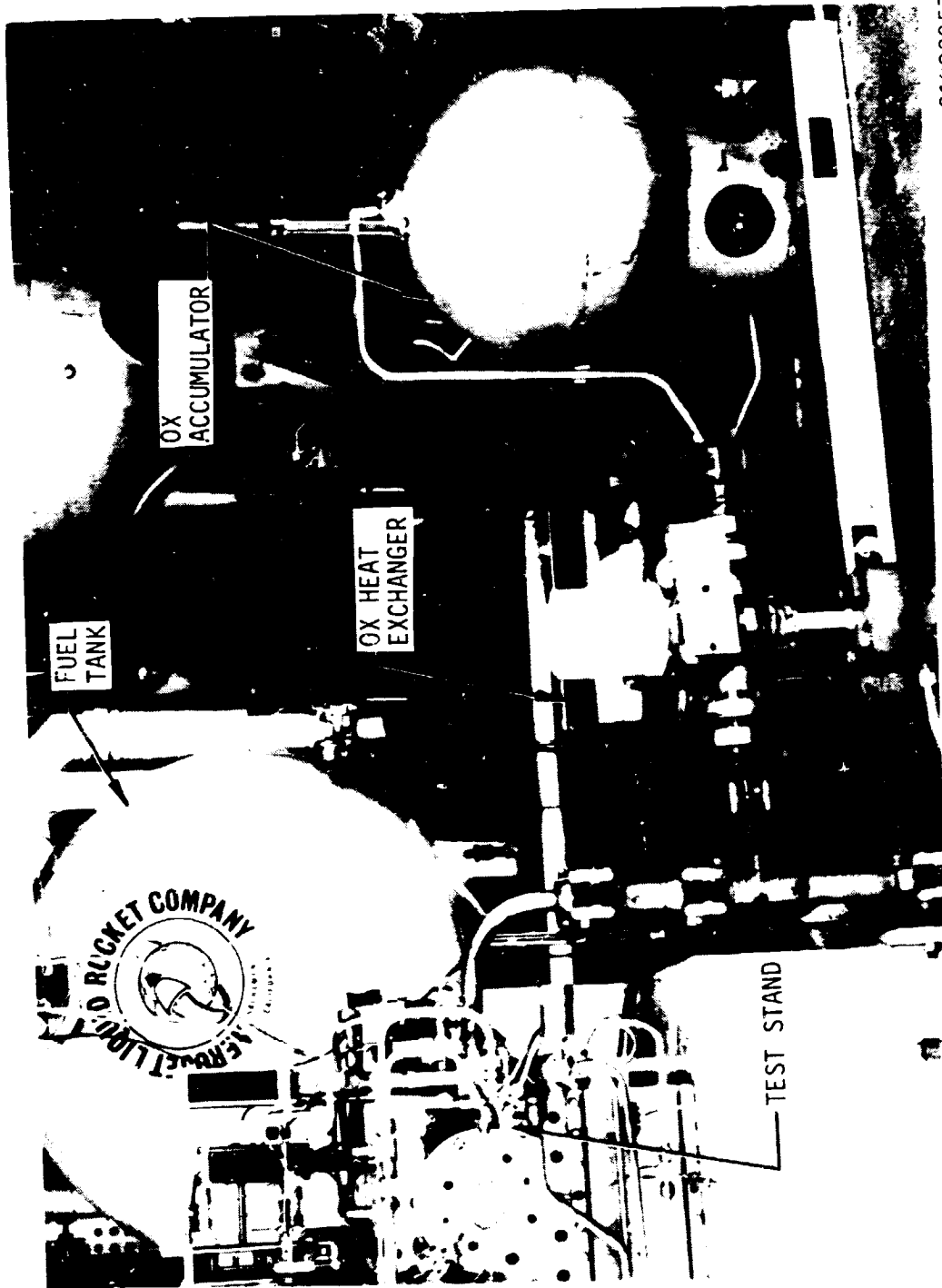

Figure 43. Space Shuttle RCS Engine Envelope

OF FOUR



C1082057

Figure 44. Bay 6 Test Facility

TABLE XI

ADDED SCOPE PLANNED GOX/ETHANOL TEST MATRIX

$T_{ox} = T_F = \text{Ambient}$
 $L' = 4.7 \text{ Inches}$

<u>Test Condition</u>	<u>Pc</u>	<u>MR</u>	<u>%FFC</u>	<u>Duration (sec)</u>
1	150	1.7	20	5
2	150	1.3	20	5
3	150	2.4	20	5
4	150	1.7	10	5
5	100	1.7	20	5
6	300	1.7	20	3
7	300	2.4	20	3

 All seven tests to be repeated with cold propellants
 ($T_{ox} = -160^\circ$ and $T_F = -125^\circ\text{F}$)

IV. B. Testing (cont.)

film-cooling requirements and stability characteristics. A prototype thruster consisting of an igniter, injector, and fuel film-cooled thrust chamber was tested over a wide range of propellant inlet pressures. Ambient and cold (-2 to -156 °F) temperature propellants were used.

The testing was conducted in two parts. The first part checked out the Task I GOX/Ethanol igniter in the Bay 6 thruster test facility. Nineteen (19) igniter tests were run to evaluate the igniter ignition limits, core to coolant fuel flow balance, valve timing, and propellant inlet pressure effects.

The second part addressed full thruster operation. Approximately 65 thruster tests were conducted. The first 13 tests were run with a heat sink chamber to evaluate thruster ignition and inlet pressure effects on performance. The remaining 52 tests were run with a thin-wall chamber to evaluate film-coolant effectiveness and pulse mode performance over a range of inlet conditions.

a. Test Setup

The testing was conducted in the Aerojet TechSystems "A" Area Research Physics Lab Test Bay 6, shown in Figure 44. This is the same facility used for the added scope testing. The propellant feed systems are shown schematically in Figure 45. The igniter propellants were fed from the main propellant lines and were orificed to provide proper flow balance. Oxygen was supplied to the engine from high-pressure storage bottles. A pebble-bed heat exchanger was used to temperature-condition the oxygen for the cold propellant tests.

The fuel was supplied to the engine from a pressurized 150-gallon tank. A tube bundle heat exchanger was used to temperature-condition the fuel for the cold propellant tests. Temperature conditioning was accomplished by flowing a mixture of liquid and gaseous nitrogen through the heat exchangers and lines.

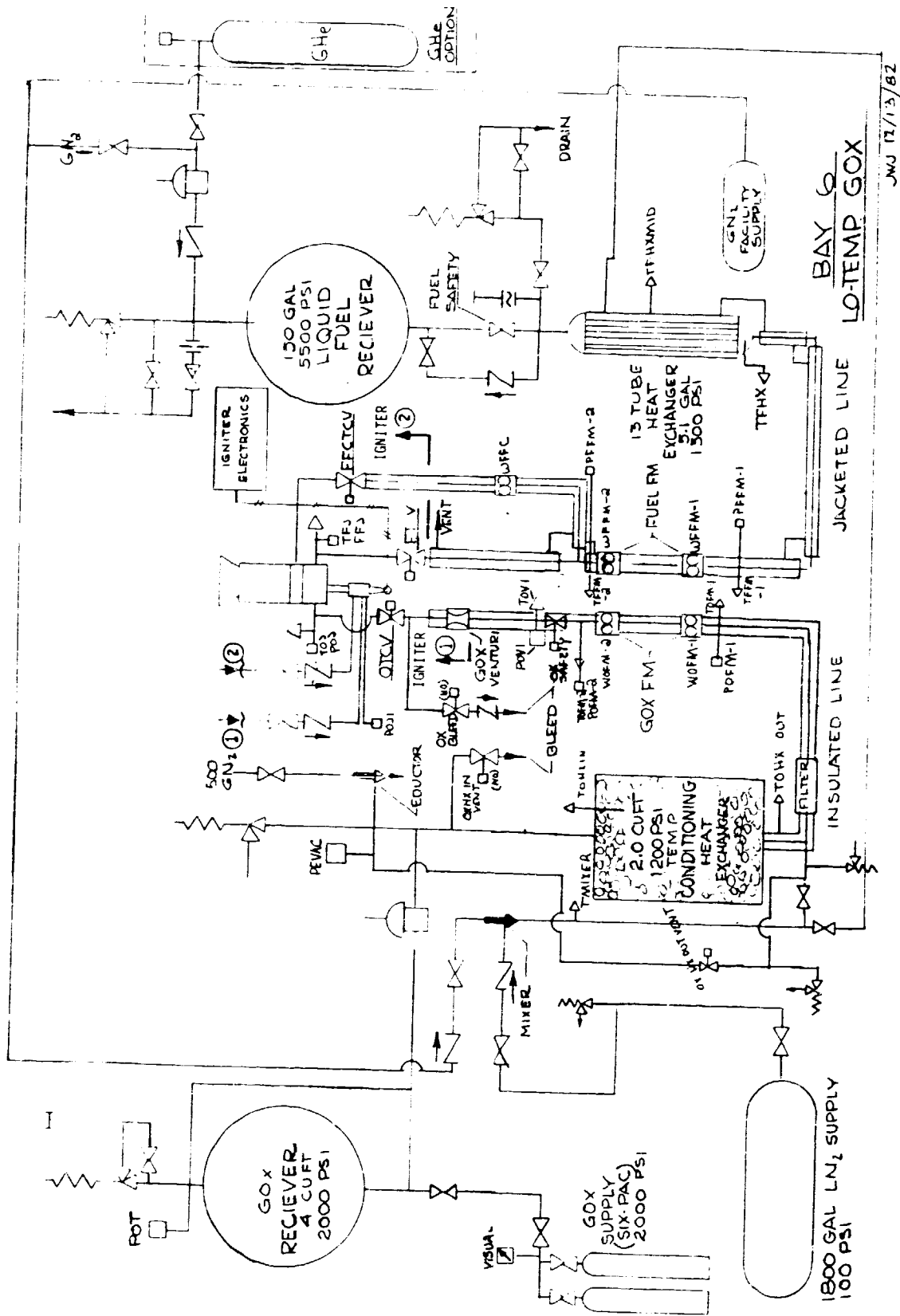

Figure 45. Bay 6 Test Facility Flow Schematic

IV. B. Testing (cont.)

The igniter was mounted in the thruster injector for the igniter-alone testing. It was instrumented as shown in Figure 46. The igniter total fuel flowrate was measured with a turbine flowmeter. The fuel core flow was determined from the calibrated injector admittance (K_w) and measured pressure drop ($P_{FIV}-P_{cIGN}$). The igniter oxidizer flowrate was determined from the calibrated injector $C_D A$ and the inlet pressure (P_{OIV}) and temperature (T_{OIV}) using the gaseous isentropic flow equation. The igniter spark was provided by a calibrated variable-energy power supply (GLA Model 30344). A spark energy of 50 mJ/SPK and a spark rate of 300 SPK/sec was used for all of the igniter and thruster tests.

The thruster assembly was instrumented to measure thrust, propellant flow-rates, inlet pressures and temperatures, combustor wall temperatures, and combustion pressures. These data were recorded on both digital and analog recording instruments as listed in Table XII. The instrumentation locations are shown in Figure 47. The thruster gaseous oxygen (GOX) flowrates were determined using a calibrated sonic venturi and the measured inlet pressure and temperature. The thruster fuel flowrate was measured using turbine flowmeters. The fuel film-coolant flowrates were determined using the FFC injector K_w and the measured pressure drops. Thruster pulse mode fuel flowrates were determined using the fuel injector K_w and the measured pressure drops ($P_{VTCV}-P_c$).

b. Thruster Test Conditions and Procedures

The igniter-alone test conditions are listed in Table XIII. The first two igniter tests (conditions 1 and 2) were coldflow tests to verify proper valve function, and igniter coolant to core fuel split (% FFC). The igniter fuel film-coolant was initially measured to be 96% as compared to the design value of 93%. Ten (10) tests (conditions 3-5) were run with the 96% fuel film-coolant to check out ignition. Poor results were achieved. The igniter fuel circuit was rebalanced to 93% FFC by placing a

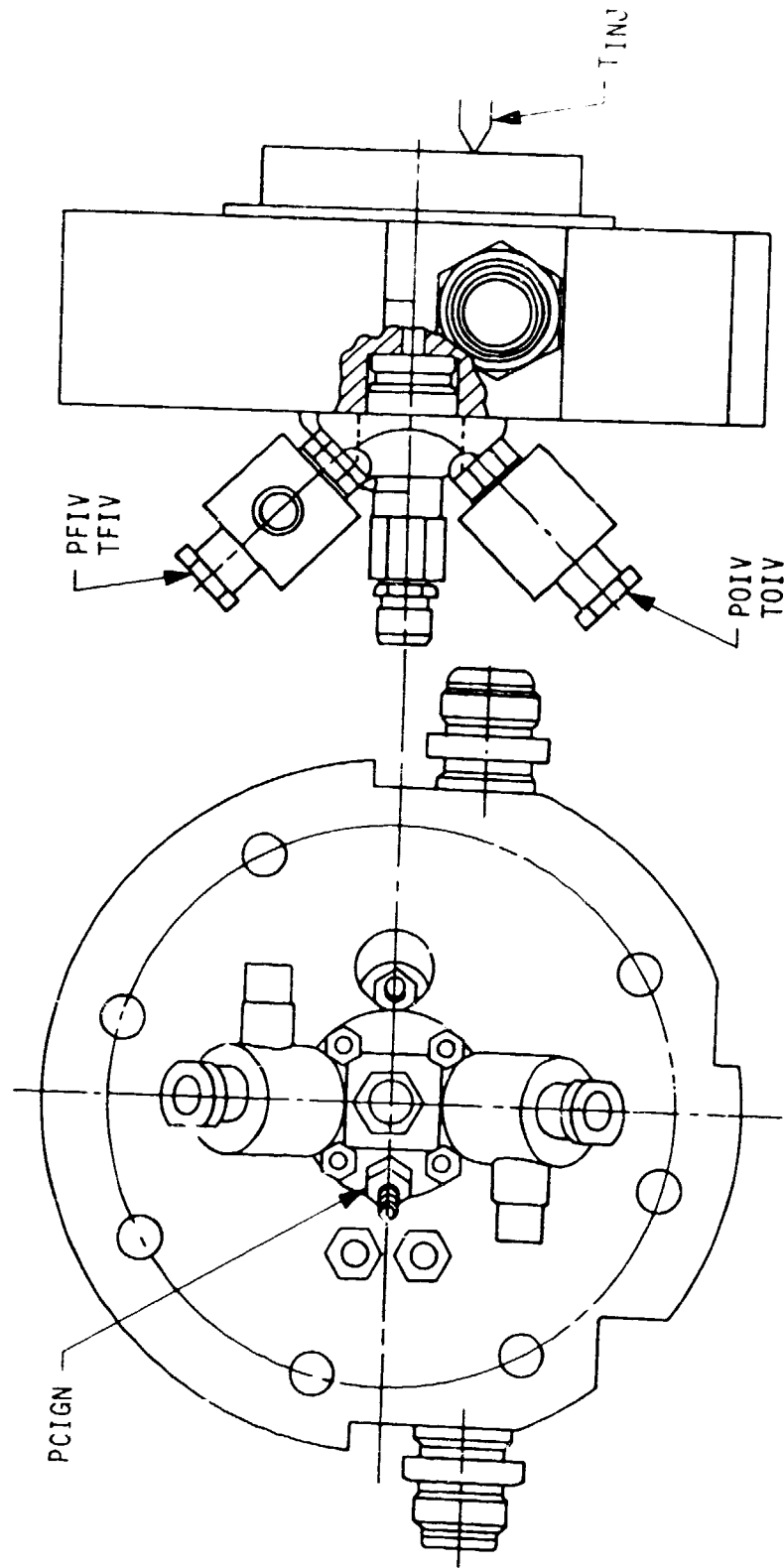

Figure 46. Task III Igniter Testing Instrumentation Locations

TABLE XII

TASK III THRUSTER INSTRUMENTATION LIST

Parameter	Symbol	Units	Range	Recording	
				Digital	O'Graph FM
Oxidizer Igniter Valve Current	IOIV	Amps	S/T		X
Fuel Igniter Valve	IFIV	Amps	S/T		X
Thrust Chamber Valve Position	LICV	%	0-100	X	X
Spark Trace	SPK	N/A	N/A		X
Oxidizer Igniter Inlet Pressure	POIV	psia	0-500	X	
Fuel Igniter Inlet Pressure	PFIV	psia	0-500	X	
Oxidizer Igniter Inlet Temperature	TOIV	±F	-200-100	X	
Fuel Igniter Inlet Temperature	TFIV	±F	-200-100	X	
Igniter Chamber Pressure	PCIGN	psia	0-500	X	X
Wall Temperature	TWALL-1,18	±F	0-2500	X	X
Injector Temperature	TINJ	±F	-200-100	X	
Oxidizer Transducer Inlet Pressure	POV	psia	0-1000	X	X
Fuel Thruster Inlet Pressure	PFV	psia	0-1000	X	X
Oxidizer Thruster Inlet Temperature	TOV	±F	-200-100	X	X
Fuel Thruster Inlet Temperature	TFV	±F	-200-100	X	X
Oxidizer Thruster Manifold Pressure	POJ	psia	0-500	X	X
Oxidizer Kistler	KOJ	psi	0-100 psi (PK-PK)	X	X
Thrust	F	lbF	0-1000		X
Chamber Kistlers	K ₁ , K ₂ , K ₃	psi	0-100 psi (PK-PK)	X	X
Igniter Oxidizer Flowrate	WOIGN	lb/sec	0.01-0.05	X	
Igniter Fuel Flowrate	WFIGN	lb/sec	0.01-0.05	X	
Thruster Oxidizer Flowrate	WO	lb/sec	0.5-2.0	X	
Thruster Fuel Flowrate	WF	lb/sec	0.25-1.25	X	
Chamber Pressure	Pc	psia	0-500	X	X

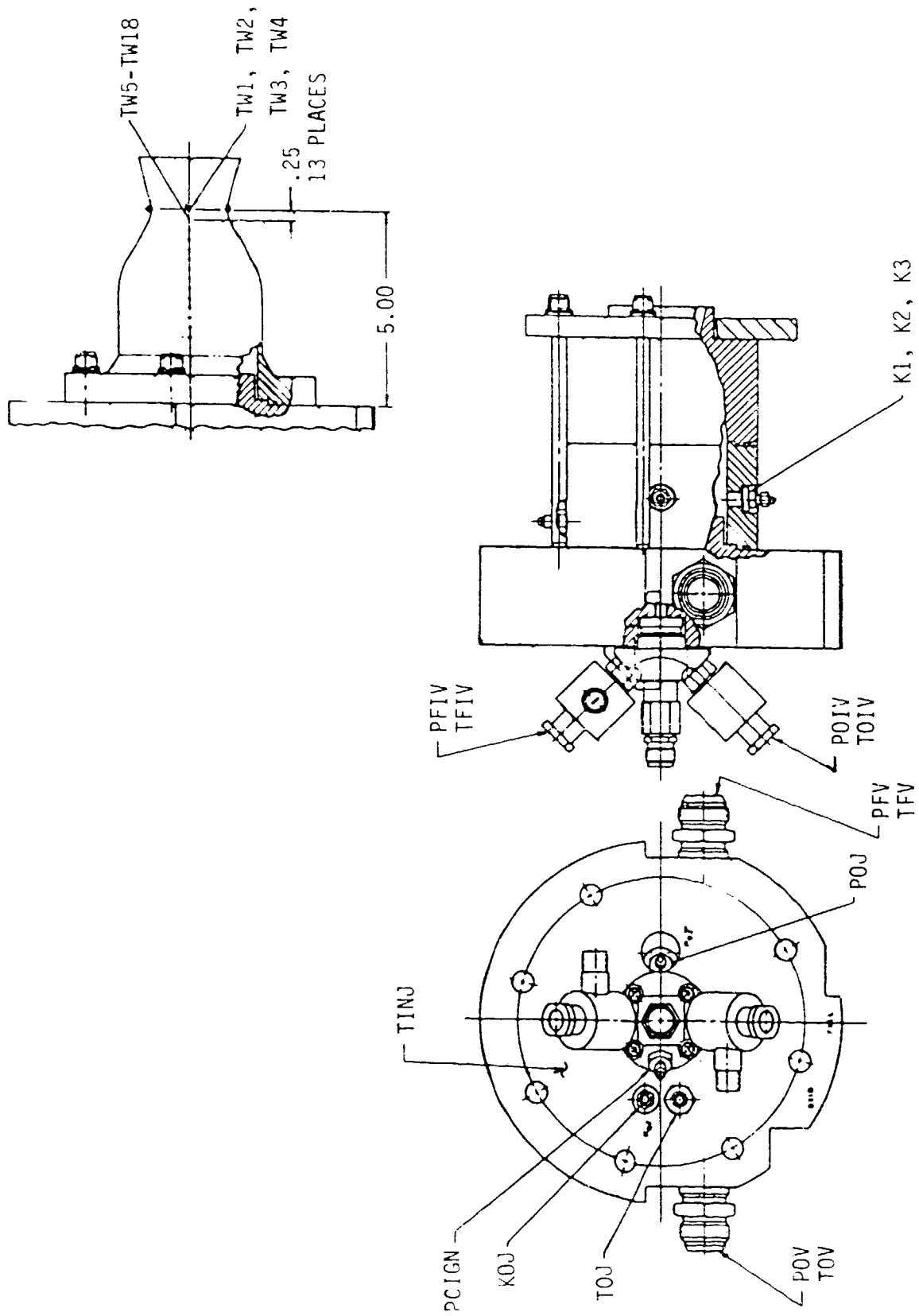

Figure 47. Task III Thruster Testing Instrumentation Locations

TABLE XIII
TASK III IGNITER TEST MATRIX

<u>Status</u>	<u>Test Condition No.</u>	<u>Test Objective</u>	<u>MR</u>		<u>Duration (sec)</u>	<u>No. of Tests</u>	
			<u>(psia)</u>	<u>Overall</u>		<u>Planned</u>	<u>Actual</u>
Complete	1	Oxidizer Cold-Flow	N/A	N/A	1	1	1
Complete	2	Fuel Cold-Flow	N/A	N/A	1	1	1
Complete	3-5	Checkout	150	1.0	1/4-1	3	11
Complete	6-10	Determine Effect of Inlet Conditions	150 ±40%	1.0 ±40%	1	5	6
						10	19

IV. B. Testing (cont.)

0.034 inch diameter orifice in the coolant circuit inlet. Seven (7) more tests (conditions 6-10) were run with 93% fuel film-coolant to determine the effect of inlet pressures on ignition. The inlet pressures were varied $\pm 40\%$ from the nominal. Good ignition results were achieved and the 93% FFC condition was selected for thruster testing.

The thruster test matrix is shown in Table XIV. Fuel and oxidizer propellant cold flow tests (conditions 1 and 2) had been planned but were considered unnecessary on the basis of the water and GN_2 cold flow results.

(1) Heat Sink Chamber

Test conditions 3-5 were run to checkout the system and igniter/valve sequence using the heat sink chamber. Three tests were planned but a total of 5 tests were run. The thruster was sequenced as shown in Figure 48. The igniter fuel valve was signaled 10 milliseconds ahead of the igniter oxidizer valve. The spark was signaled on with the fuel valve. The thruster bipropellant valve was signaled on about 45 milliseconds from the igniter fuel valve signal to permit time for the computer to test the igniter chamber pressure. If the igniter chamber pressure had not achieved a preselected level then the test would have been terminated. Ignition was achieved on all of these tests.

Test conditions 11-15 were run to determine the effect of inlet pressures on thruster ignition, performance and stability. Five (5) tests were planned and eight (8) tests were completed. The inlet pressures were varied $\pm 40\%$ from their nominal values. These ignitions were so smooth and reliable that the planned torch ignition test conditions 6-10 were considered unnecessary and were deleted from the test program. However, subsequent testing with cold propellant led to a condition of delayed thruster ignition which suggests that torch ignition limits should be explored on any future test program.

TABLE XIV

TASK III THRUSTER TEST MATRIX

Test No.	Status	Test Condition No.	Test Objective	Propellant Temperature	Pc	MR	Igniter Mr	% FFC	Duration (sec)	Chamber	# of Tests Planned	# of Tests Actual
	Deleted	1	Oxidizer Cold-Flow	Ambient	N/A	N/A	N/A	N/A	1	Heat Sink	1	0
	Deleted	2	Fuel Cold-Flow	Ambient	N/A	N/A	N/A	N/A	1	Heat Sink	1	0
	Complete	3-5	Checkout Sequence	Ambient	Nominal	Nominal	Nominal	Nominal	1/4-2	Heat Sink	3	5
	Deleted	6-10	Determine Torch Ignition Limits	Ambient	Nominal	Nominal	Nominal ±40%	Nominal	1/2	Heat Sink	5	0
	Complete	11-15	Determine Inlet Condition Effects	Ambient	Nominal ±40%	Nominal ±40%	Nominal ±40%	Nominal ±40%	1/2	Heat Sink	5	8
		16-25	Determine Propellant Temperature Effects	Cold	Nominal ±40%	Nominal ±40%	Nominal ±40%	Nominal ±40%	2	Thin Walled	10	13
148-150	Complete	26-29	Checkout	Ambient	Nominal	Nominal	Nominal	Nominal	1	Thin-Walled	4	2
133-143	Complete	30-34	Inlet Condition Effects	Ambient	Nominal ±40%	Nominal ±40%	Nominal ±40%	Nominal ±40%	5	Thin-Walled	5	22
151-160	Complete	35-39	Evaluate Pulse Capability	Ambient	Nominal	Nominal	Nominal	Nominal	0.5-0.04	Thin-Walled	5	6
	Complete	40-45	Evaluate of Inlet Conditions on Pulse Performance	Ambient	Nominal ±40%	Nominal ±40%	Nominal ±40%	Nominal ±40%	0.08	Thin-Walled	6	6
	Complete	46	Demonstrate Pulse Train	Ambient	Nominal	Nominal	Nominal	Nominal	0.100-0.050	Thin-Walled	1	3
											16	65

Nominal Pc = 150 psia
 Nominal MR = 1.8
 Nominal Igniter MR = 1.0
 Nominal %FFC = 26%

ORIGINAL
OF POC...

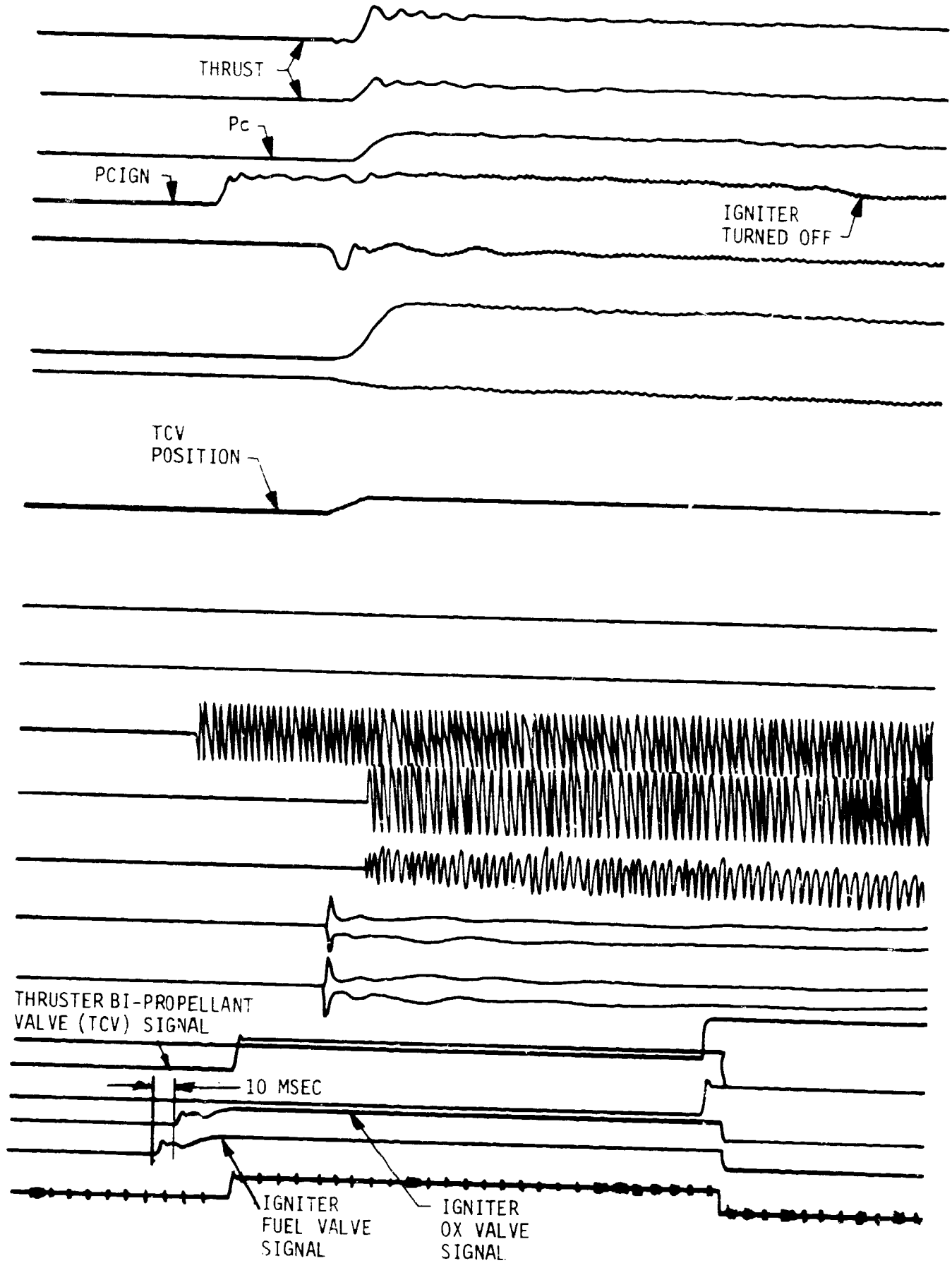

Figure 48. Thruster Ignition Sequence - Steady State Testing

IV, B, Testing (cont.)

(2) Thin-wall Chamber Tests

The first thin-wall chamber tests (conditions 26-29) were run to verify proper thruster/igniter function. Four (4) tests were planned but only 2 were needed to verify proper function. Two sets of test conditions 30-39 were run. The first set was run with the tangential fuel film-coolant injection scheme and the second with the swirl injection scheme. Modifications to the thrust chamber valve actuator were also made prior to running the second set of tests. Test conditions 30-34 were run to evaluate the effect of inlet pressures on thruster performance and cooling. Nine (9) tests were run with the tangential fuel-film coolant and thirteen (13) tests with the swirl fuel-film coolant. The chamber pressure was varied over the range of 91 psia to 197 psia. The mixture ratio ranged from 0.778 to 2.86. The test durations varied from 1.0 to 5.1 seconds due to automatic throat temperature kills set to prevent throat overheating. The start sequence was the same as that used for the heat sink chamber.

Test conditions (35-39) were run to demonstrate thruster pulse mode capability and determine the minimum pulse width achievable. Four (4) pulse tests were run with the tangential fuel-film coolant and two (2) with the swirl injection. The first four (4) tests were single pulses varying in duration from 472 ms to 178 ms. The second two (2) tests were a series of seven (7) pulses varying in duration from 200 ms to 40 ms, with as little as one (1) second coast between pulses. All tests were run with nominal inlet pressures. Pulse mode capability was limited for the first four (4) tests by the thruster bipropellant valve pintle travel time. The valve pintle took 20 msec to open and 50 msec to close. These long travel times coupled with long electrical lags in the pilot valves prevented achieving pulses shorter than 178 milliseconds. The goal was for 80 milliseconds. The valve was subsequently reworked to speed the pintle travel time by driving the actuator with GHe rather than GN₂. The pilot valve electrical lags were also reduced with an electronic valve driver.

IV, B, Testing (cont.)

The GN₂ driven valve sequence used for the first four (4) pulse tests is shown in Figure 49. The thruster bipropellant valve (TCV) was signaled on ahead of the igniter valves. The fuel igniter valve was timed to follow by 20 ms. The spark was actuated with the fuel valve, and the oxidizer valve was set to follow by 10 ms. On shutdown, the TCV was signaled off about 80 ms ahead of the igniter valves.

The GHe driven valve sequence used for the remainder of the pulse tests is shown in Figure 50. The thruster bipropellant valve (TCV) was signaled 45 ms ahead of the igniter fuel valve. The spark and igniter fuel valve were started simultaneously. The oxidizer valve was lagged by 10-20 ms. The TCV pintle travel times were 10-20 ms for open and less than 5 ms for close. The TCV pilot valve electrical lag was reduced from 120 ms to 15 ms. The shortest pulse achieved was 40 ms.

Test conditions 40-45 were run to determine the effect of inlet pressure on pulse performance. These tests were made with the swirl fuel-film coolant and GHe actuated valve. The valves were sequenced the same as shown in Figure 50. Two (2) 80 ms pulses with a one (1) second coast was run on each of the tests.

Test condition 46 was run to demonstrate pulse mode capability. Two pulse tests were run using the same start sequence as the previous test conditions (40-45). Each of the pulse tests contained a string of seven (7) pulses, three (3) 100 msec, two (2) 70 msec and two (2) 50 msec. The pulses were separated by 65 msec coasts.

Test conditions 16-25 were run to determine the effect of cold (-125 F) propellant on thruster ignition and performance. Ten (10) tests were planned but thirteen (13) were completed, eight (8) steady-state and five (5) pulse tests. These tests were run with the thin-walled chamber rather than the heat sink chamber as originally planned. The swirl film-coolant injector and the GHe driven valve were used. The start sequence

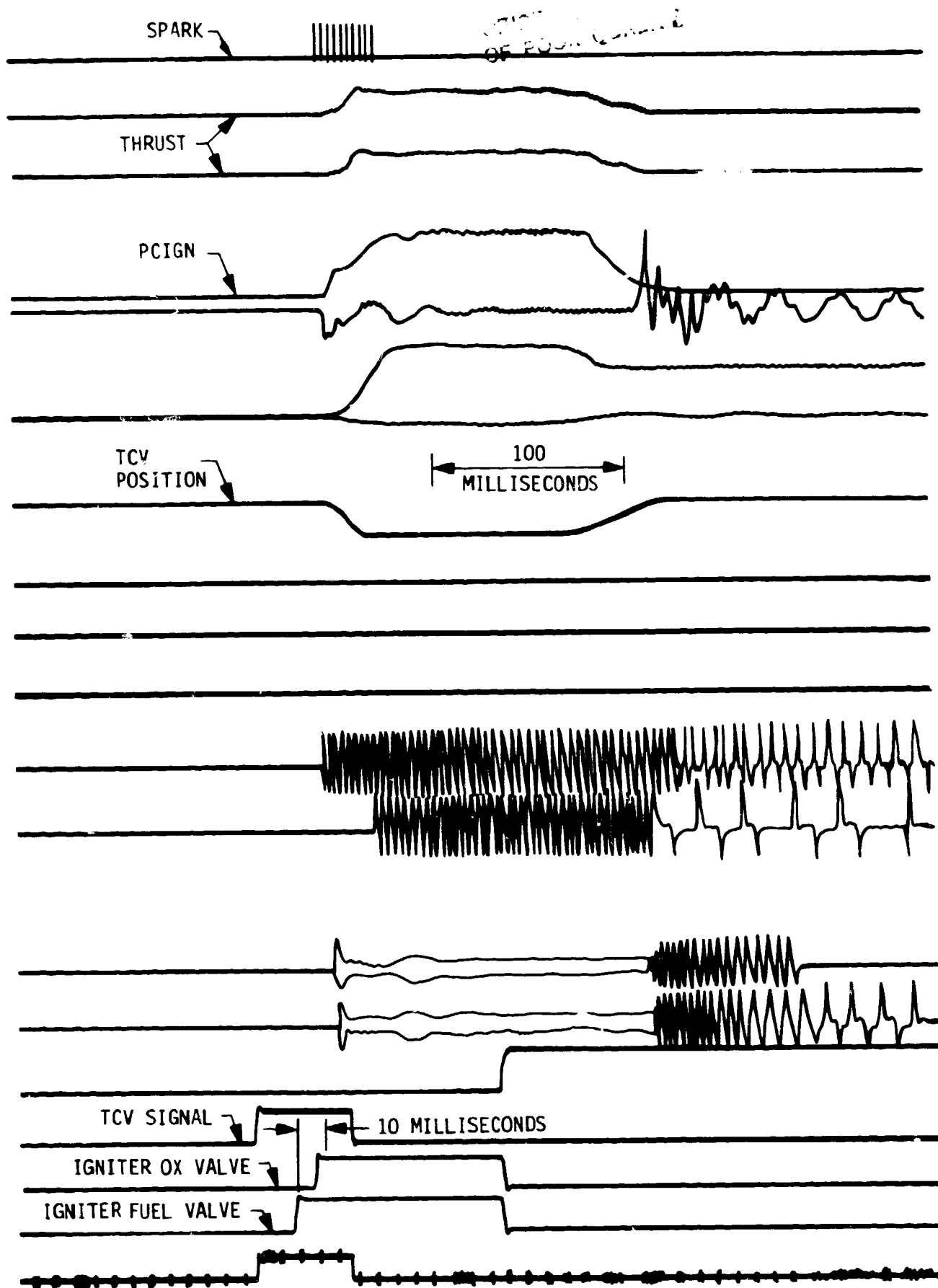

Figure 49. Thruster Pulse Sequence - GN_2 Actuator

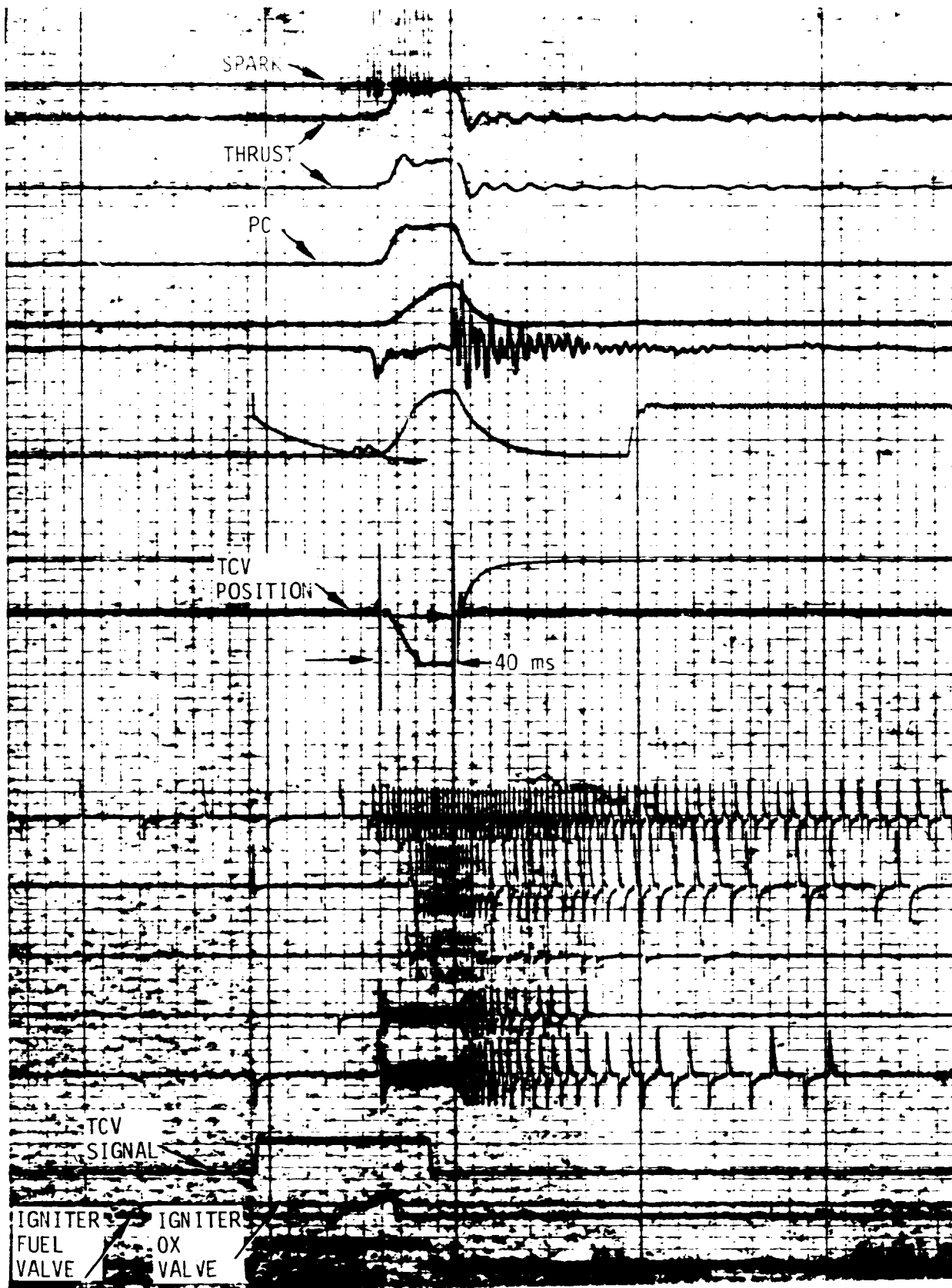

Figure 50. Thruster Pulse Sequence - GHe Actuator

IV, B, Testing (cont.)

used for the steady-state tests was the same as that used for the heat sink chamber. The steady-state test durations varied from about 1.0 to 5.0 seconds as determined by the throat temperature kills. Tests covered the Pc range from 74 to 188 psia and the mixture ratio range from 1.24 to 3.29. The pulse tests used the same sequence of seven (7) pulses used for test condition 46.

C. DATA ANALYSIS

This section of the report discusses and interprets the test data. The Task I ignition testing, added scope testing and Task III thruster testing are all discussed.

1. Task I Igniter Test Results

The ignition test variables and the range of conditions tested are listed in Table I. The effects of these variables were determined by plotting the ignition response (i.e., ignition or non-ignition) on the flame quench parameter (PD) versus core mixture ratio coordinates. The flame quench parameter is the product of the cold-flow pressure before ignition and the chamber diameter. It is derived from an analysis of the flame quench process (see Ref 3).

The effect of chamber diameter and cold-flow pressure on ignition is shown in Figure 51. Ignition is indicated by the open symbols and non-ignition by the closed symbols. Data are shown for the 0.15 inch diameter chamber and the 0.3 inch diameter chamber with and without a nozzle. The 0.3 inch diameter chamber was modified by inserting a 0.15 in. nozzle at the chamber exit as shown in Figure 12. The intent of the modification was to increase the chamber pressure for a given flow rate and reduce the oxidizer injection velocity to determine its effect on the ignition. The propellants were at ambient temperature. The spark energy and spark rate were held constant at 50 millijoules and 300 SPS respectively. Also shown on the figure are the predicted flame quench limits and the selected igniter design operating point. The core ignition mixture ratio of 10 differs from the steady-state mixture ratio of 15 due to increased fuel-flow before ignition.

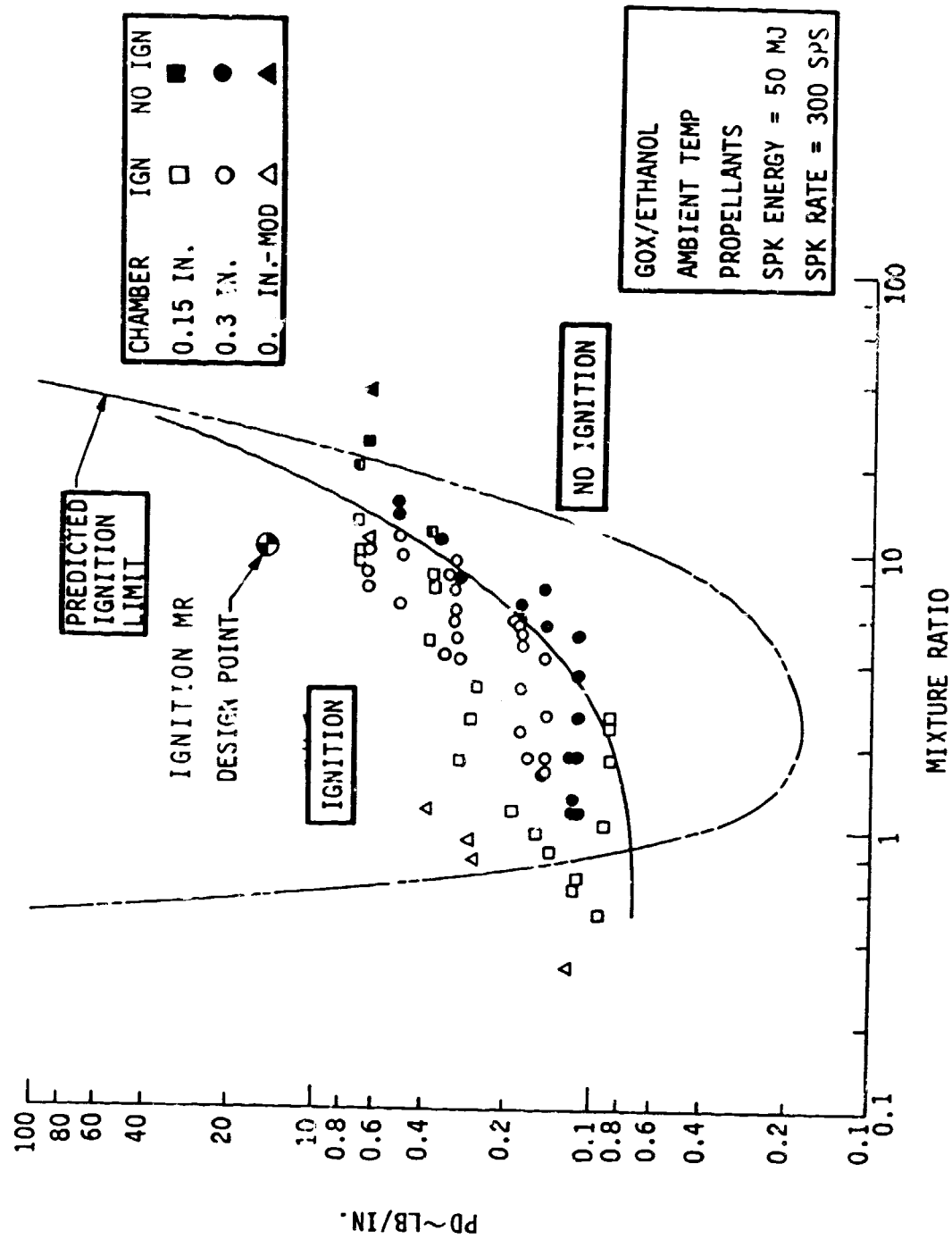

Figure 51. Effect of Igniter Chamber Diameter and Cold-Flow Pressure on Ignition

IV, C, Data Analysis (cont.)

The data show that the ignition limit is shifted to the left of the predicted limits and that the fuel-rich limit occurs at much lower mixture ratios than predicted. The disagreement between the .3 inch ID and .15 inch ID data near $PD = 0.1$ is believed due to poor mixing between the ox and fuel streams which was caused by the high axial momentum of the GOX in the 0.3 inch configuration (highest flow rate through the annulus surrounding the spark electrode). See Reference 3, Figure 15.

The effect of spark energy on ignition limits is shown in Figure 52. The data for 10 millijoules and 30 millijoules spark energy are plotted on the PD vs MR coordinates. The 50 millijoules energy correlation is taken from Figure 51. The data show that reducing the spark energy from 50 to 10 millijoules reduces the ignition limits. It was recommended that 50 millijoules be used for thruster applications to maximize ignition margin.

The effect of cold propellant is shown in Figure 53. The fuel temperatures ranged from -102°F to -121°F and the GOX temperatures ranged from -89°F to -129°F . Both 0.15 inch diameter and 0.3 inch diameter data were obtained. The results show that the cold propellants only slightly reduce the ignition limits. The effect of independently varying the fuel and oxidizer is shown in Figure 54. These data show that the ignition limit is sensitive only to the fuel temperature. This is probably due to vaporization effects which are temperature dependent. It was concluded that the igniter would ignite reliably at the design point with cold propellant.

The cooled igniter chamber ignition limit data are plotted in Figure 55. Both ambient and cold propellants were tested. Agreement with the uncooled chamber data is evident by comparing the data to the uncooled chamber data. It is concluded that the cooled chamber ignition limits are the same as for the uncooled chambers.

Igniter C^* performance was obtained for the 5 second duration igniter cooling tests. Both cold and ambient propellant temperature data are plotted in Figure 5. The theoretical One Dimensional Equilibrium (ODE) C^* is

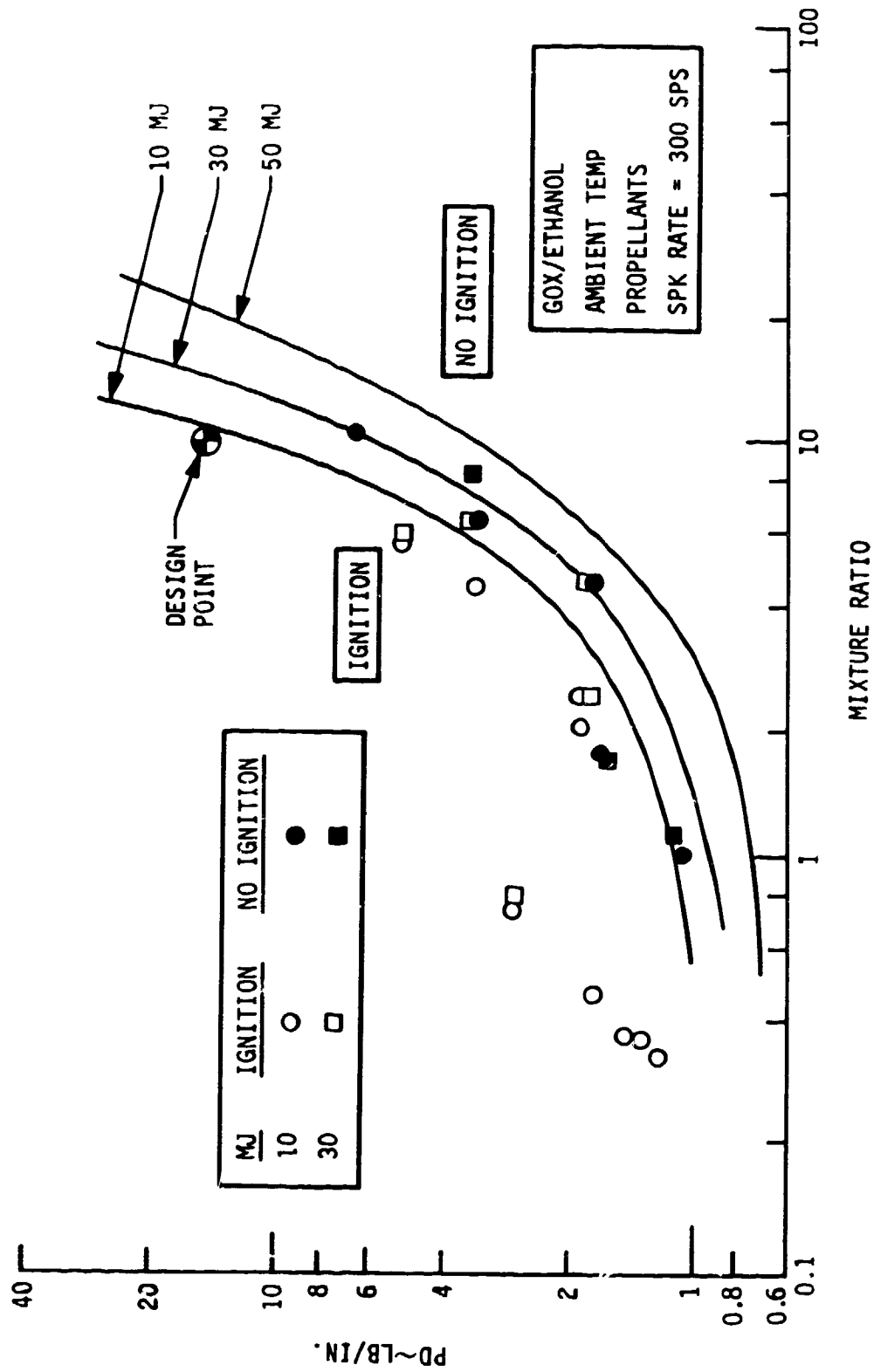

Figure 52. Effect of Spark Energy on Ignition

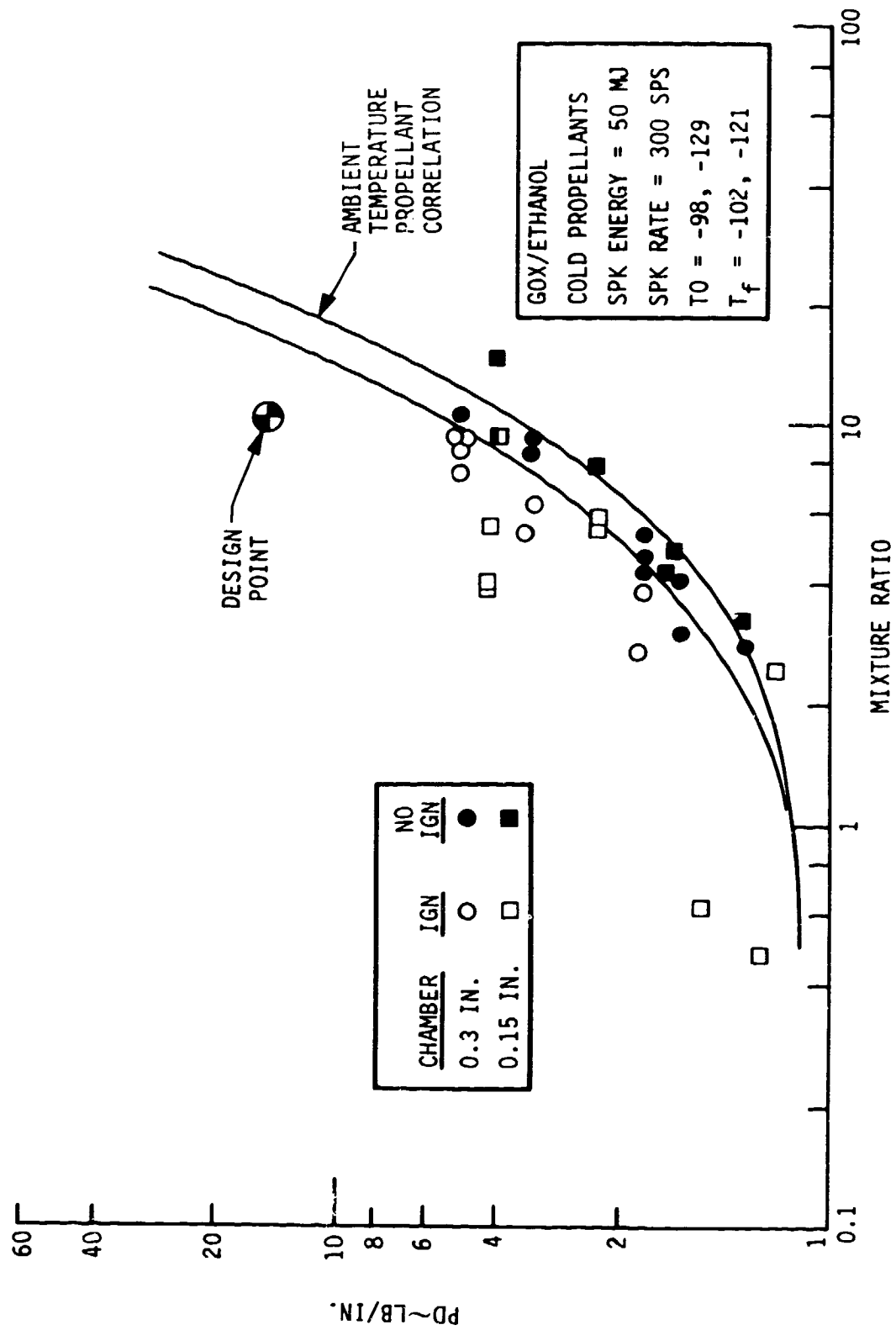

Figure 53. Effect of Cold Propellant on Ignition

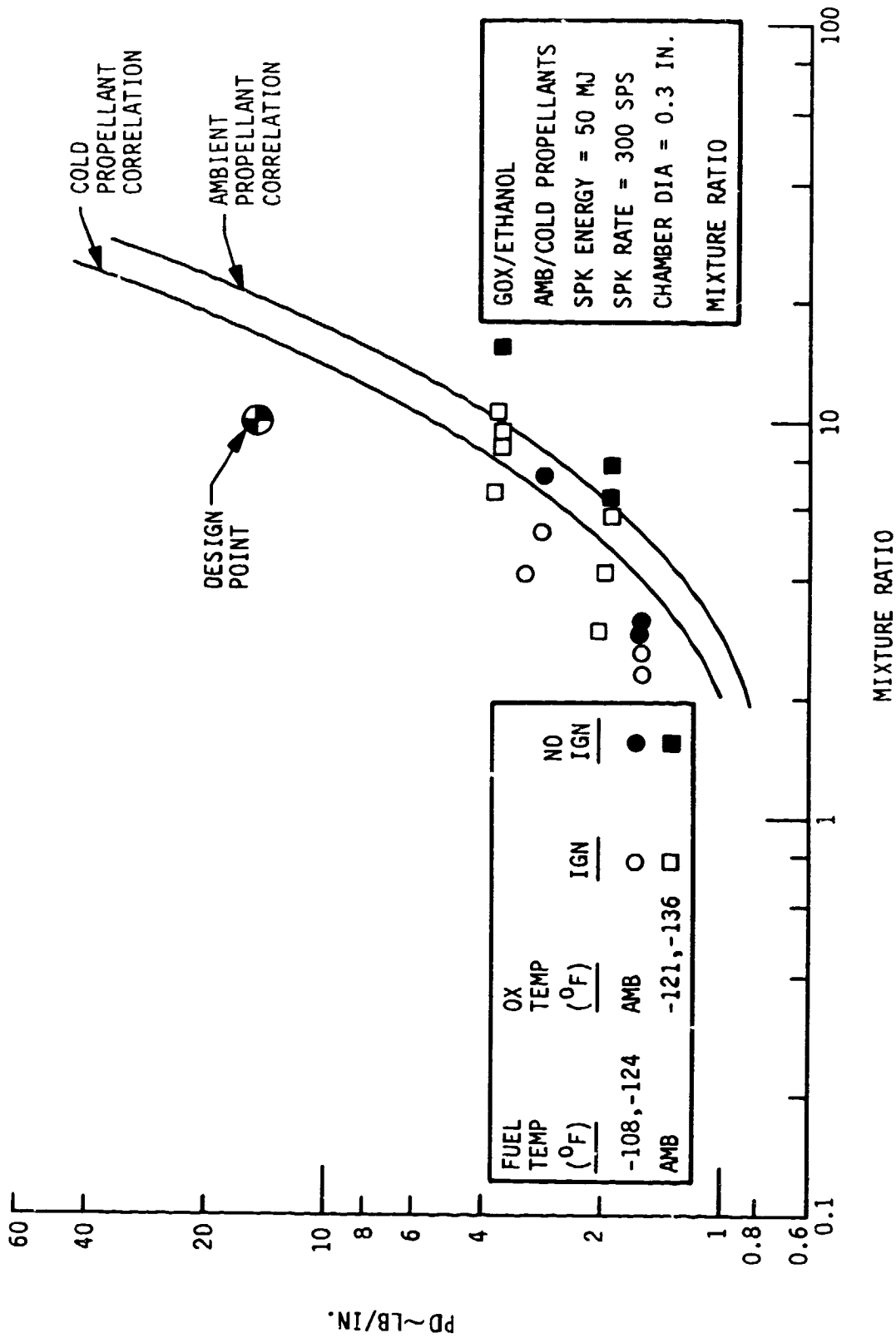

Figure 54. Effect of Fuel and Ox Temperature on Ignition

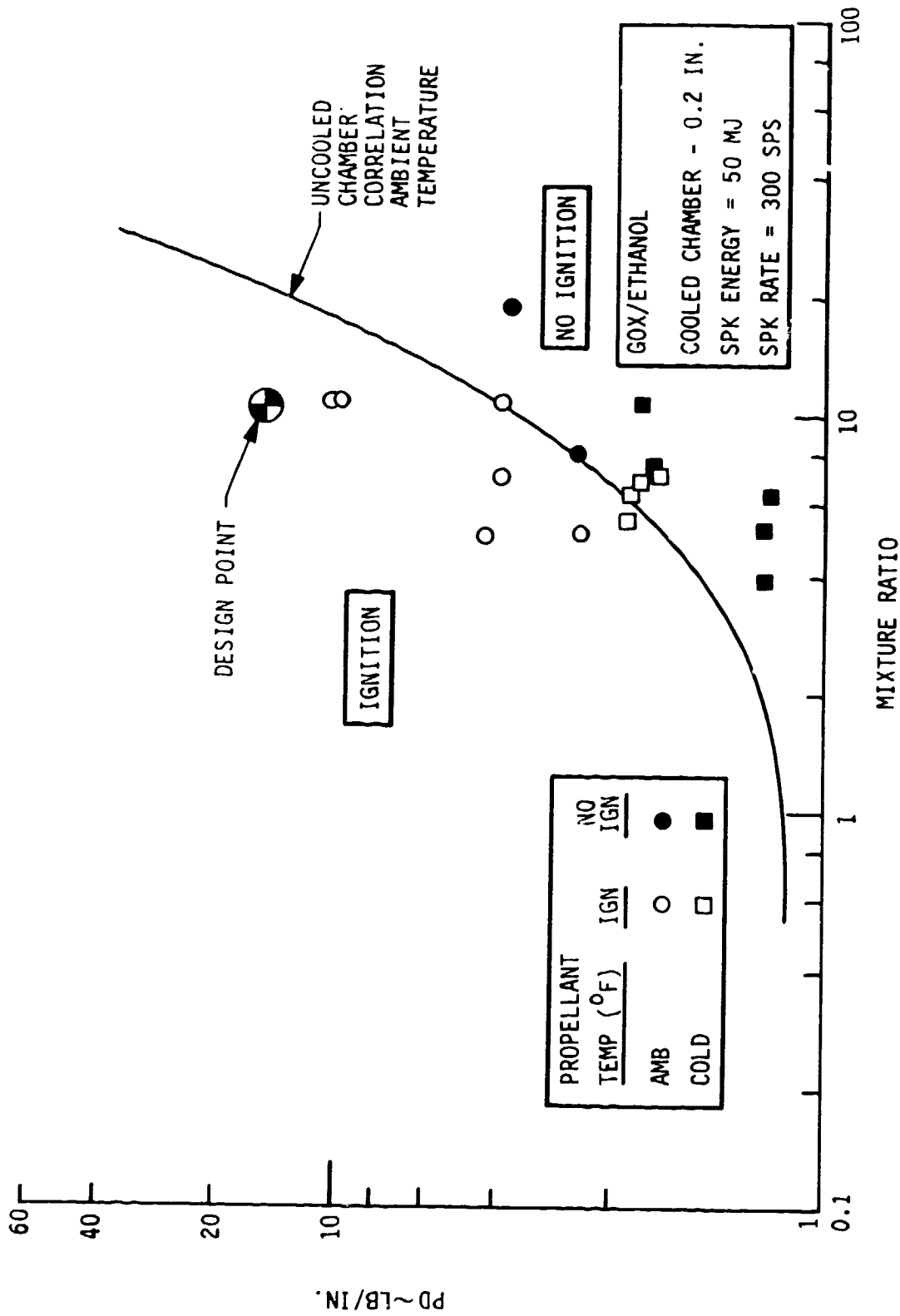

Figure 55. Cooled Igniter Chamber Ignition Limits

IV, C, Data Analysis (cont.)

plotted for reference. Ninety-three percent (93%) fuel coolant is the design point coolant. It is seen that cold propellant significantly reduces C^* due to poor vaporization. However, it was concluded that the igniter has adequate performance for thruster applications.

Igniter cooling tests were run with both ambient and cold propellants and with different amounts of fuel coolant. The fuel coolant amount was adjusted by changing the orifice at the chamber coolant inlet.

The igniter heat fluxes were calculated from the coolant flowrate and temperature rises. These data were correlated with the $V\Delta T$ parameter in Figure 56. The $V\Delta T$ is the product of the coolant propellant subcooling (i.e., $T_{SAT} - T_{INLET}$). A correlation obtained from the literature and used in the design activity is shown for comparison. The igniter data agrees with this correlation. It was concluded that the igniter has adequate cooling margin at the design point for thruster application.

Fourteen pulse mode tests were conducted, six with ambient propellant and eight with cold propellant, to demonstrate pulse mode capability and evaluate oxidizer manifold contamination problems. These tests were conducted at vacuum conditions. The test results are summarized in Table XV.

All of the ambient temperature tests ignited with no problem and exhibited smooth repeatable combustion. Figure 57 shows the pulse string for Test 287. No oxidizer manifold disturbances were observed. Minor combustion roughness was observed with cold propellant at the start. However, combustion smoothed out as the igniter warmed up. It was concluded that the igniter can be operated in the pulse mode with ambient or cold propellant at the nominal inlet conditions.

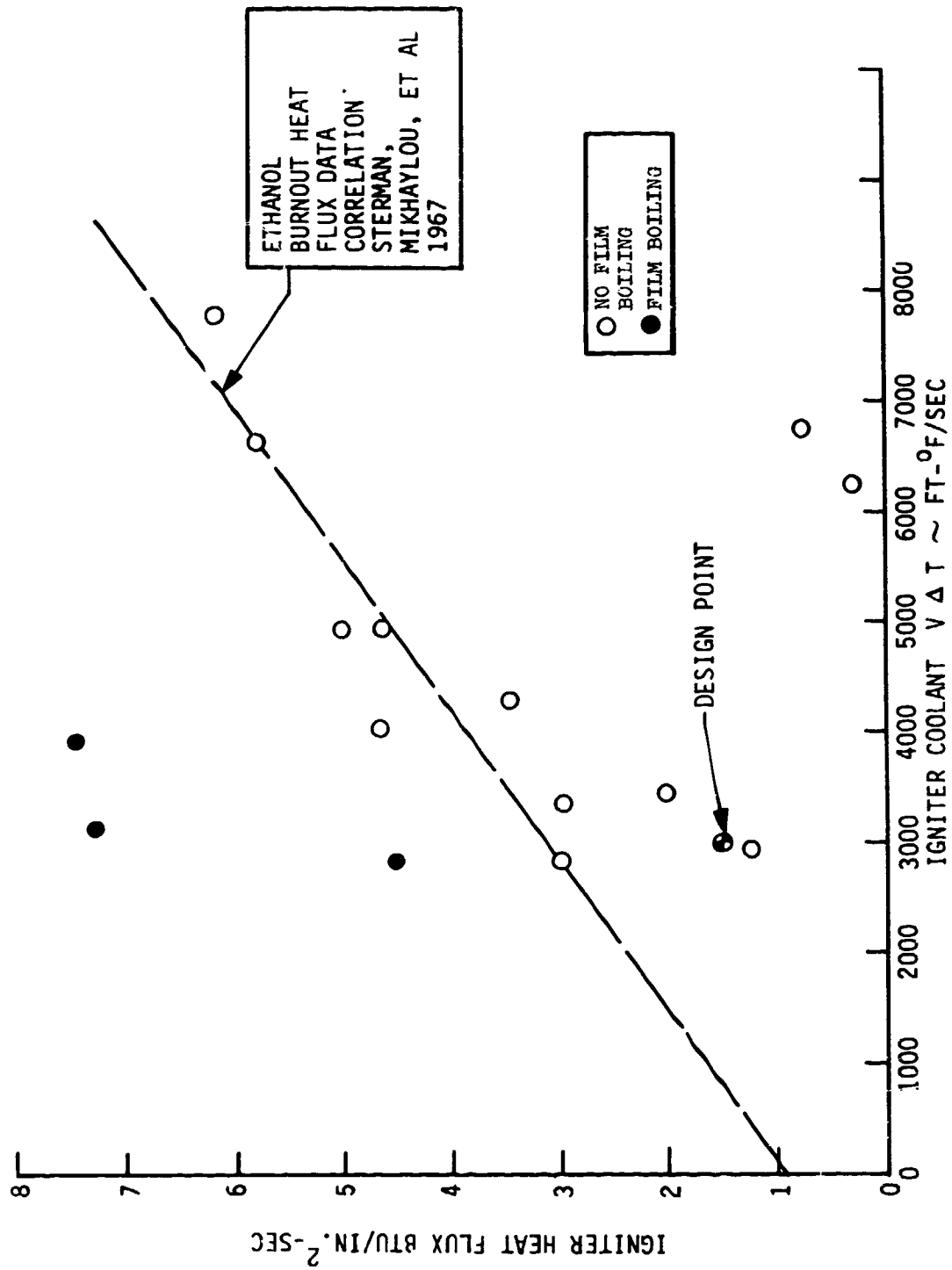

Figure 56. Igniter Heat Flux Correlation

TABLE XV

TASK I IGNITER PULSE TEST SUMMARY

Test No.	Propellant Condition	Chamber Pressure (psia)	MR	On Time (sec)	Off Time (sec)	No. of Pulses	Ignition	Oxidizer Manifold Spikes
284	Ambient	136	1.16	0.5	1.0	?	Yes	No
285	Ambient	140	1.10	0.5	1.0	2	Yes	No
286	Ambient	139	1.06	0.5	1.0	2	Yes	No
287	Ambient	141	1.09	0.2	0.2	5	Yes	No
288	Ambient	138	1.06	0.2	0.2	5	Yes	No
289	Ambient	75	0.760	0.2	0.2	5	Yes	No
301	Cold	167	1.89	0.5	1.0	2	No Ignition on 2nd Pulse +	No
302	Cold	148	1.58	0.5	1.0	2	Yes	No
303	Cold	141	1.33	0.5	1.0	2	Yes	No
304	Cold	134	1.36	0.2	1.0	2	Yes	No
305	Cold	147	1.61	0.2	1.0	2	Yes	Minor
306	Cold	*-	-	0.2	1.0	2	No**	No
307	Cold	*-	-	0.2	1.0	2	No**	No
308	Cold	128	1.12	0.2	1.0	2	Yes	No

* Reduced Inlet Pressures for 75 psia Point

** Predicted No Ignition

+ Fuel Frozen in Injector

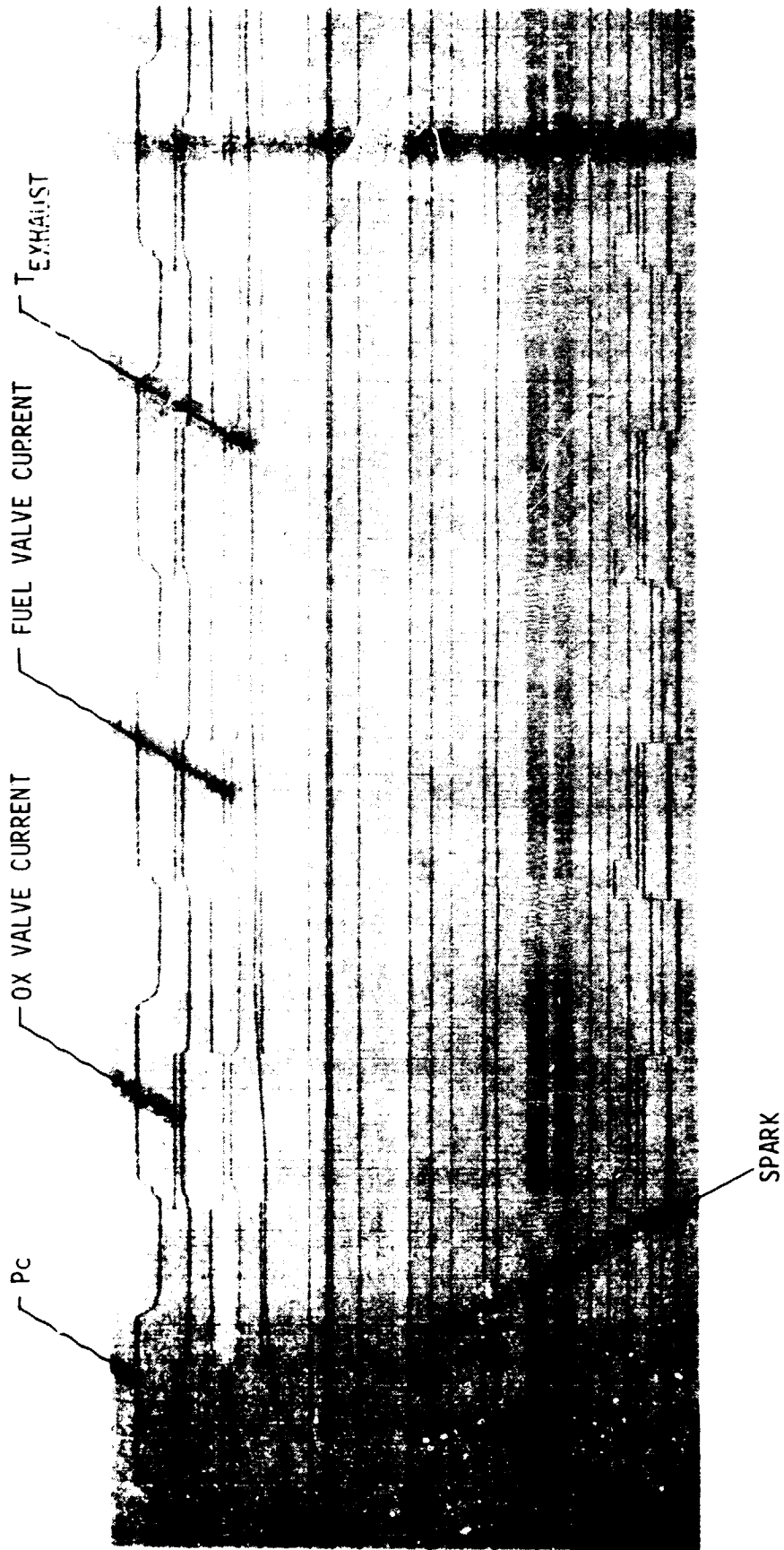

Figure 57. Igniter Pulse Mode Sequence - Ambient Propellant

IV, C. Data Analysis (cont.)

Several gas generator tests were run to evaluate the potential for carbon formation and deposition at extreme fuel-rich conditions. The results are summarized in Table XVI. Tests were made with both ambient and cold propellants. No evidence of carbon formation was observed in the exhaust plume or on the hardware. Color sequence pictures of the exhaust plume were taken for this purpose. It was concluded that ethanol is extremely clean burning and has excellent combustion characteristics for gas generator operation.

2. Added Scope Test Results

The added scope test results are summarized in Table II. Nine ambient temperature and ten cold propellant temperature tests were made. Two data points for each test were analyzed to provide performance with and without fuel film cooling. The fuel film coolant was terminated two seconds before shutdown on most of the tests for this purpose.

The test data indicate efficiencies of 96-98% for the uncooled (film coolant turned off) tests at chamber pressures of 150 psia. Uncooled test data at a chamber pressure of 300 psia indicate combustion efficiencies of 97-99%. With the addition of approximately 20% fuel film cooling the combustion efficiencies drop 2 to 5%, depending on chamber pressure.

The cold propellant tests with no film cooling show combustion efficiencies of 89 to 92%. The Task II analysis had indicated that the cold propellant performance would be reduced by 15%. The test data show a reduction of only 2 to 5%. It was concluded that performance of the Swirler/-Like Doublet OFO injector would be adequate for thruster application.

The effect of fuel film coolant on performance is shown in Figure 58. It was concluded that thin wall chamber thermal data are required to accurately establish fuel film cooling requirements.

TABLE XVI

GAS GENERATOR TEST SUMMARY

<u>Test No.</u>	<u>Propellant Condition</u>	<u>Pc (psia)</u>	<u>MR</u>	<u>Duration (sec)</u>	<u>Carbon Formation</u>
239	Ambient	Invalid	Data	1.75	No
240	Ambient	85.0	0.382	3.5	No
241	Ambient	84.3	0.392	3.6	No
242	Ambient	87.7	0.399	3.3	No
243	Ambient	71.1	0.304	5.0	No
244	Cold	92.5	0.441	5.0	No
245	Cold	92.3	0.433	5.0	No
246	Cold	73.1	0.264	5.0	No
247	Cold	54.2	0.189	5.0	No

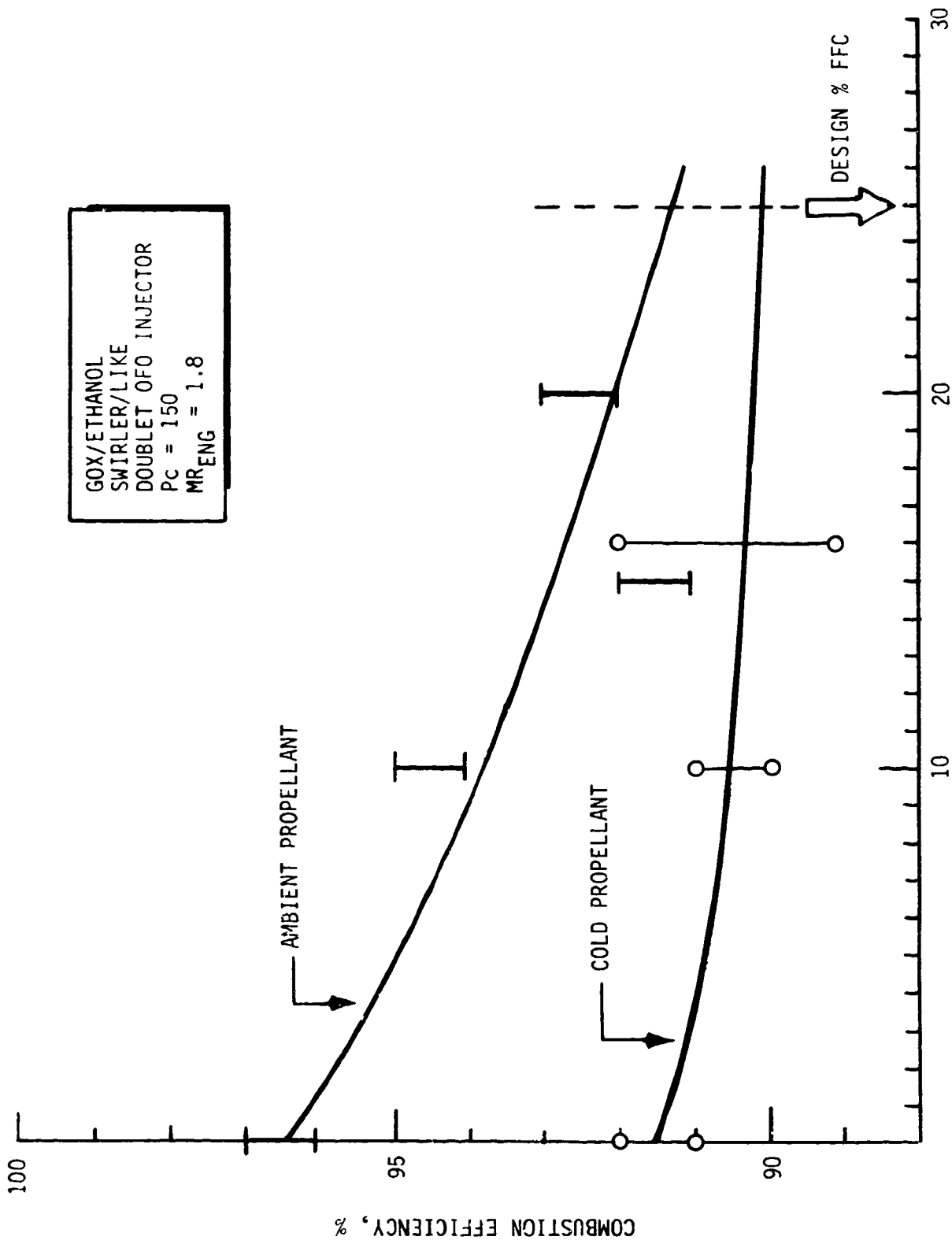

Figure 58. Effect of Fuel Film Coolant on Performance

IV, C, Data Analysis (cont.)

All of the tests exhibited smooth stable combustion. No evidence of any combustion oscillations was observed.

3. Task III Thruster Test Results

This section of the report discusses the Task III igniter and thruster test data results.

a. Igniter-Alone Tests Results

Nineteen igniter tests were run, two cold-flow and 17 hot firings. The hot firings were made over the range of conditions listed in Table XVII. The test data are summarized in Table XVIII. A photograph of a typical igniter firing is shown in Figure 59. The first ten firings were made with the igniter fuel flow balanced to 96% fuel film-coolant to provide more cooling margin than the design value of 93%. The 96% balance point caused more fuel to flow through the cooling circuit and less through the core. The result was to shift the core ignition mixture ratio to the non-ignition regime as defined during the Task I testing. Seven of the ten tests were non-ignition.

The remaining 7 tests were run at the 93% fuel film-coolant condition. Ignition was achieved at 6 of the 7 conditions with the 93% balance. Only the low fuel pressure inlet condition (Test 118) exhibited non-ignition due to a shift in core mixture ratio to the non-ignition regime. Ignition was subsequently achieved at this condition by providing a 20 msec fuel lead (test 119). The fuel lead provided a momentary fuel rich mixture in the core at ignition, thus driving the core mixture ratio from the non-ignition regime to the ignition regime. Based on these results a 10-20 msec fuel lead was selected for the thruster testing which followed.

TABLE XVII

TASK III IGNITER TEST CONDITIONS

Chamber Pressure	88.5-161 psia
Overall Mixture Ratio	0.381-1.65
% Fuel Film Coolant Flow	96% & 93%
Core Mixture Ratio	5.6-24.9
Fuel Lead	0 msec & 20 msec
Spark Energy	50 MJ/SPK
Spark Rate	300 SPKS/sec
Propellant Temperatures	51± - 78±F

TABLE XVIII

TASK III IGNITER TEST RESULTS

Test No.	Objective	POIV (psia)	PFIV (psia)	TOIV (°F)	TFIV (°F)	PCIGN (psia)	-O (lb/sec)	-f (lb/sec)	-f _{CORE} (lb/sec)	MR Core Overall	MR Core Hotfire	MR Core Cold Flow	PD Cold Flow	FFC Cold Flow	C* (ft/sec)	Duration (sec)	Remarks
101	Ox Cold Flow	334	-	78	-	29.8	0.0213	-	-	-	-	-	6.0	-	-	1	
102	Fuel Cold Flow	-	221	-	60	15.6	-	0.0446	0.00159	-	-	-	3.1	96.4	96.4	1	K _W = 0.00353
103	Checkout	335	219	74	57	31.5	0.0214	0.0426	0.00142	0.502	-	15.0	6.3	96.7	-	0.25	No Ignition
104	Checkout	335	219	74	57	31.0	0.0214	0.0423	0.00142	0.505	-	15.0	6.3	96.6	-	0.25	Repeat of 103
105	Checkout	329	223	61	52	32.0	0.0213	0.0430	0.00145	0.495	-	14.7	6.4	96.7	-	0.25	Extended Electrode 0.021" - No Ignition
106	Checkout	334	222	61	52	32.7	0.0216	0.0438	0.00143	0.493	-	15.0	6.5	96.7	-	0.25	Repeat of 105
107	Checkout	203	224	59	51	*88.5	0.0131	0.0323	0.00129	0.405	10.0	8.28	3.95	96.0	1971	0.25	Reduced Ox Inlet Pressure - Ignition
108	Checkout	308	304	61	51	32.1	0.0199	0.0521	0.00175	0.381	-	11.3	6.4	96.6	-	0.25	Increased Fuel Inlet Pressure-No Ignition
109	Checkout	336	229	66	56	32.7	0.0217	0.0410	0.00146	0.529	-	14.8	6.5	96.4	-	0.25	No Ignition
110	Checkout	349	328	66	56	*135	0.0226	0.0391	0.00154	0.577	14.5	11.8	6.8	96.0	2212	0.25	Ignition
111	Checkout	354	289	66	56	35.0	0.0228	0.0426	0.00168	0.534	-	13.6	7.0	96.0	-	0.25	No Ignition
112	Checkout	339	317	64	56	*138	0.0219	0.0372	0.00148	0.588	14.7	11.6	6.4	96.0	2361	1	Ignition
113	Checkout	335	228	63	55	130	0.0216	0.0221	0.00156	0.979	13.8	9.8	6.5	92.9	3014	0.25	Rebalance FFC Flow - 0.034" Orifice
114	Checkout	328	225	63	55	*131	0.0211	0.0213	0.00152	0.992	13.8	9.7	6.4	92.8	3129	1	K _W = 0.0025
115	Determine Effect Of Inlet	193	226	61	55	*110	0.0125	0.0229	0.00169	0.545	7.4	5.6	4.7	92.6	3117	1	
116	Condition Inlet	444	226	64	55	*153	0.0287	0.0193	0.00134	1.48	21.3	13.5	8.6	93.0	3223	1	
117	Condition Inlet	331	309	63	56	*161	0.0214	0.0258	0.00189	0.829	11.3	8.25	6.2	92.7	3456	1	
118	Condition Inlet	333	139	64	56	31.9	0.0215	0.0198	0.00161	1.086	-	13.4	6.3	91.9	-	1	No Ignition
119	Condition Inlet	329	139	63	56	*109	0.0213	0.0129	0.000853	1.65	24.9	13.4	6.3	93.4	3226	1	Repeat of 118 W/20MS Fuel Lead

* Ignition Obtained In These Tests
Spark Energy = 50 mJ/SPK
Spark Rate = 30 SPS

ORIGINAL PAGE IS
OF POOR QUALITY.

ORIGINAL PICTURE
OF POOR QUALITY

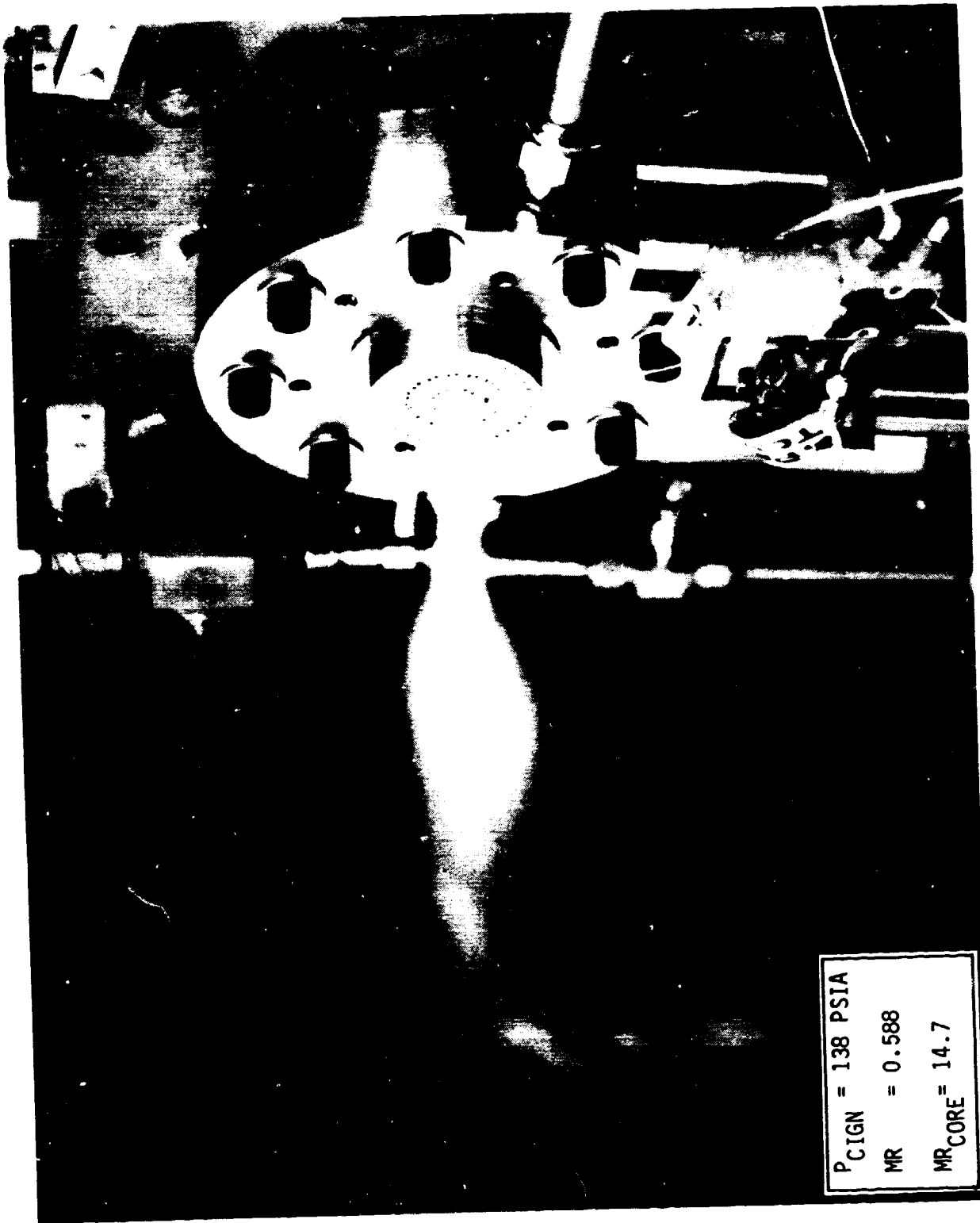

(CI083 005)

Figure 59. GOX/Ethanol Igniter Firing

IV, C, Data Analysis (cont.)

Ignition data from these 17 tests are plotted in Figure 60 along with the Task I ignition correlation for comparison. These results are considered to be in good agreement with the Task I results. The igniter was deemed satisfactory for thruster testing.

b. Thruster Test Results

(1) Heat Sink Chamber

Thirteen heat sink chamber tests were run to evaluate ignition and thruster performance. The performance data for the heat-sink chamber tests are summarized in Table XIX. Data are listed for two summary periods for the longer (2 sec) duration tests. The vacuum specific impulse (I_{spVAC}) is plotted versus mixture ratio in Figure 61. Included in Figure 61 is the ODE I_{spVAC} for comparison.

The I_{sp} efficiency, shown in Figure 62, reaches a minimum near stoichiometric mixture ratio which may be indicative of significant mixing losses due to blow-apart. The same trend was observed with this pattern on the mid-Pc program (NAS 9-15958) and during the added scope (WBS 8.0) testing. The I_{sp} efficiency at the design mixture ratio of 1.8 is about 90% which is close to that expected with 25% fuel film-cooling.

Examination of the high frequency data show unorganized combustion noise levels of 5-6% of Pc. No organized oscillations were observed. Post-test examination of the hardware showed it to be clean with no evidence of thermal incompatibility. The exhaust plumes were observed to be clear with no evidence of carbon formation.

Task III Igniter Testing

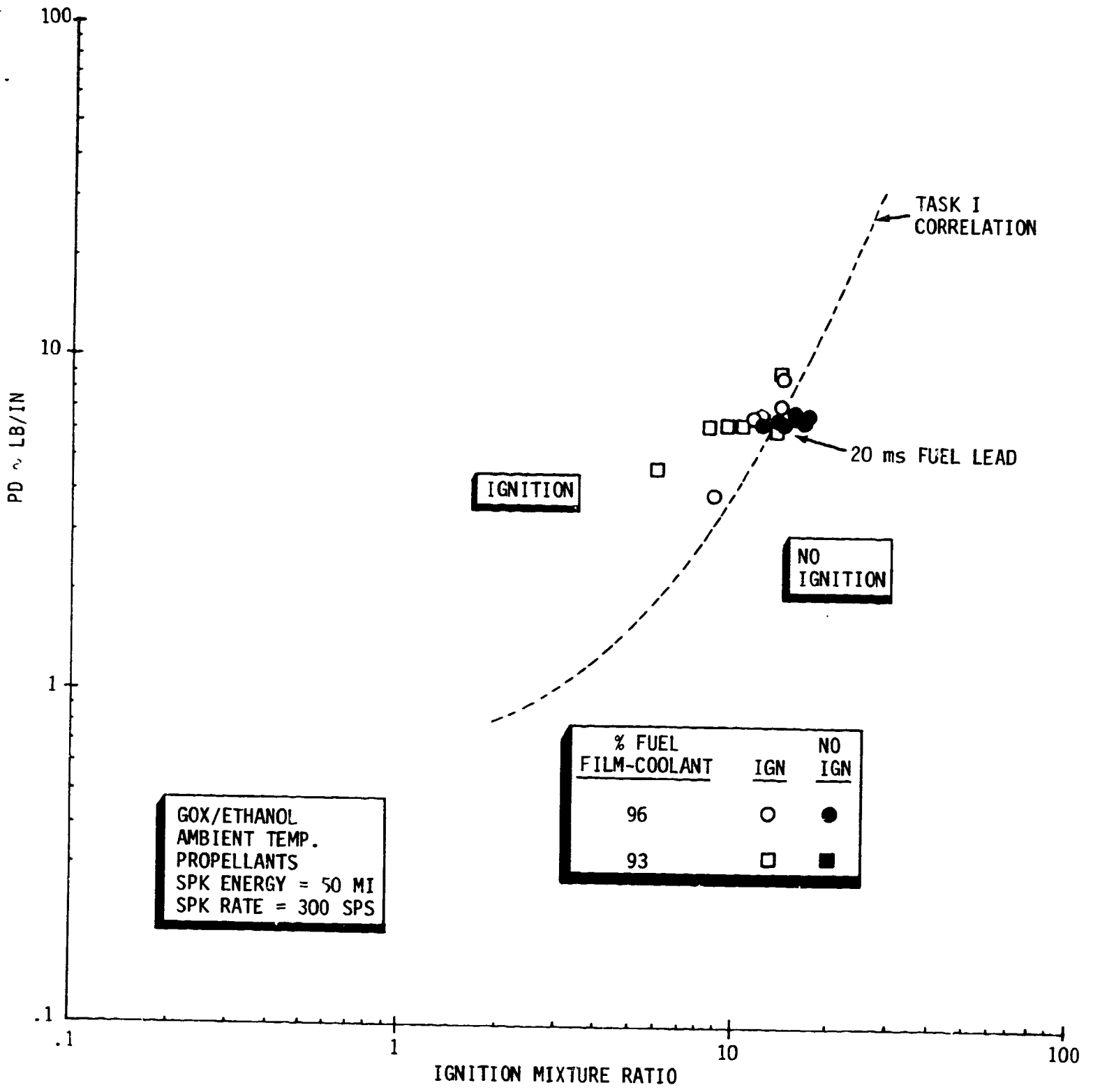

Figure 60. Ignition Limit Data - Task III Igniter Testing

TABLE XIX'

PERFORMANCE DATA SUMMARY - HEAT SINK CHAMBER

Test No.	Duration (sec)	Data Period (sec)	FFC Injectors	PFTCV (psia)	POTCV (psia)	TFTCV (°F)	TOTCV (°F)	Pc (psia)	MR _E	W _T (lb/sec)	F _{vac} (lbf)	C* (ft/sec)	I _{sp vac} (sec)	"C* (%)	"I _{sp v} (%)
120	0.5	0.2/0.35	TANG	288	322	Amb	Amb	129.8	1.427	1.823	411.9	5196	225.9	92	87
121	0.5	0.2/0.55	TANG	291	360	Amb	Amb	141.1	1.663	1.952	446.6	5274	228.7	93	89
122	1.0	0.2/0.6	TANG	295	353	Amb	Amb	139.9	1.609	1.946	444.7	5247	228.5	93	88
		0.6/1.0	TANG	295	357	Amb	Amb	140.5	1.633	1.958	447.4	5237	228.5	93	88
123	2.0	0.2/0.6	TANG	295	357	Amb	Amb	140.4	1.630	1.953	445.3	5246	228.0	93	88
		1.0/2.0	TANG	294	363	Amb	Amb	141.4	1.667	1.969	449.8	5241	228.5	93	89
124	2.0	0.2/0.6	TANG	310	352	Amb	Amb	145.2	1.523	1.949	446.4	5436	229.0	96	88
		1.0/2.0	TANG	310	363	Amb	Amb	148.4	1.597	1.981	457.2	5467	230.8	97	89
125	2.0	0.2/0.6	TANG	309	352	Amb	Amb	147.9	1.510	1.919	445.7	5624	232.2	99	90
		1.0/2.0	TANG	308	355	Amb	Amb	148.8	1.542	1.934	448.8	5617	232.1	99	90
126	2.0	0.2/0.6	TANG	303	354	Amb	Amb	147.6	1.545	1.941	444.1	5552	228.9	98	88
		1.0/2.0	TANG	303	358	Amb	Amb	149.3	1.586	1.955	449.4	5572	229.9	98	89
127	2.0	0.2/0.6	TANG	189	340	Amb	Amb	123.4	2.259	1.642	376.4	5483	229.3	101	92
		1.0/2.0	TANG	189	359	Amb	Amb	127.4	2.484	1.705	389.5	5454	228.5	102	93
128	2.0	0.2/0.6	TANG	429	338	Amb	Amb	152.7	1.098	2.117	457.8	5266	216.3	97	88
		1.0/2.0	TANG	428	360	Amb	Amb	159.7	1.206	2.192	480.4	5317	219.2	96	87
129	2.0	0.2/0.6	TANG	308	213	Amb	Amb	103.7	0.786	1.551	307.7	4881	198.3	104	93
		1.0/2.0	TANG	308	213	Amb	Amb	104.1	0.793	1.552	308.5	4891	198.7	103	92
130	2.0	0.2/0.6	TANG	187	205	Amb	Amb	92.5	1.108	1.250	276.8	5399	221.4	99	89
		1.0/2.0	TANG	187	212	Amb	Amb	95.2	1.181	1.275	285.0	5450	223.5	99	89
131	2.0	0.2/0.6	TANG	432	490	Amb	Amb	188.1	1.761	2.586	593.7	5311	229.6	95	89
		1.0/2.0	TANG	431	495	Amb	Amb	189.5	1.800	2.605	597.8	5307	229.5	95	90
132	2.0	0.2/0.6	TANG	313	469	Amb	Amb	170.1	2.177	2.298	532.7	5401	231.9	99	93
		1.0/2.0	TANG	313	503	Amb	Amb	176.7	2.433	2.422	555.1	5321	229.1	99	93

FFC = 26%
 Ambient Propellants (T₀ = 58-65°F, T_f = 50-53°F)

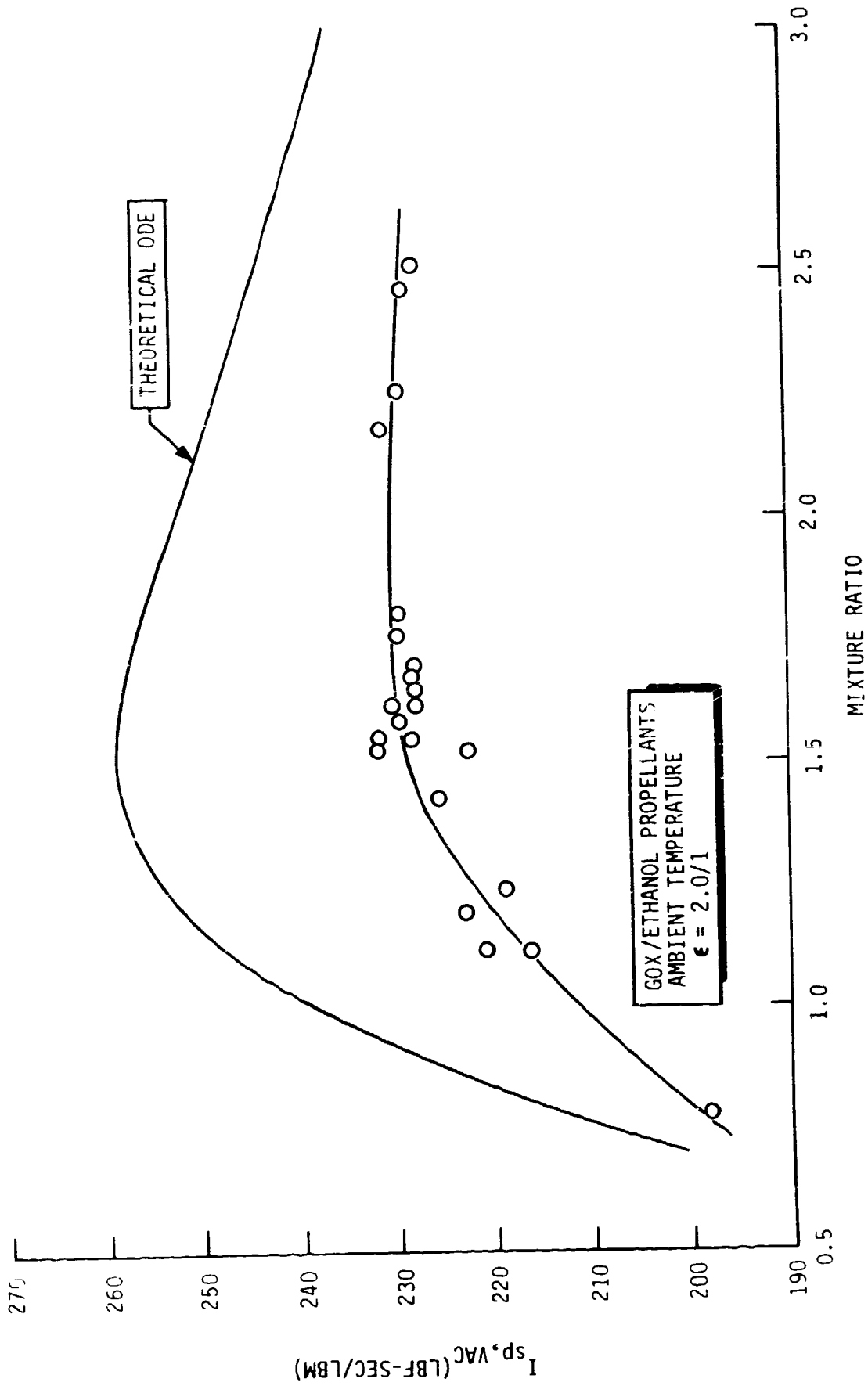

Figure 61. Thruster Isp Performance - Heat Sink Chamber

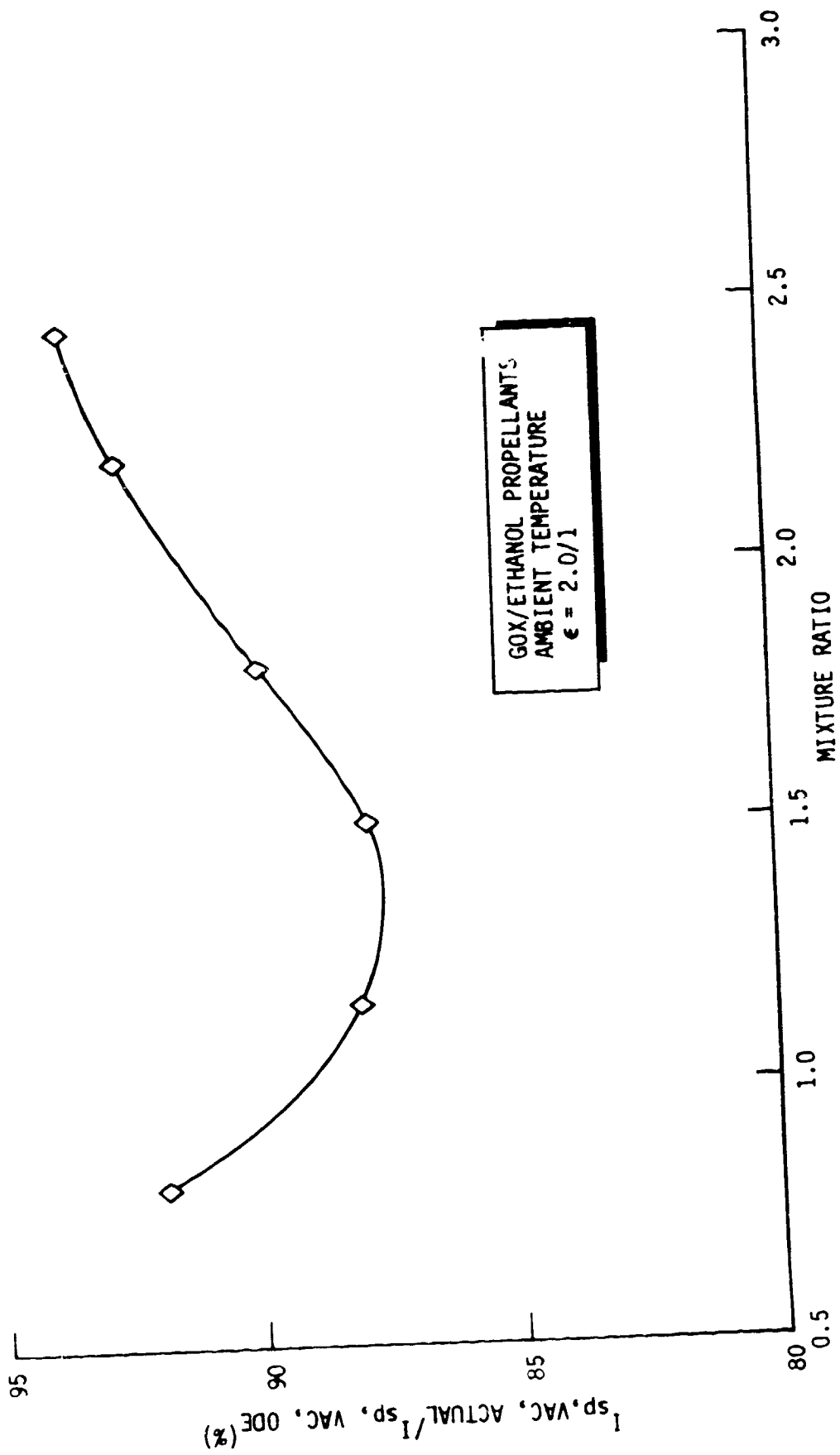

Figure 62. Thruster Isp Efficiency - Heat Sink Chamber

IV, C, Data Analysis (cont.)

The igniter operating conditions for all of the heat sink chamber tests are listed in Table XX. The igniter steady-state chamber pressure runs 26-72 psi higher than the thruster chamber pressure due to the pressure drop through the igniter tube. The igniter overall mixture ratio varied from 0.557 to 3.0 over the $\pm 40\%$ range of inlet pressures. All ignitions were smooth and without overpressures.

(2) Thin-Wall Chamber

Fifty-two thin-wall chamber tests were run, thirty-two steady-state and twenty pulse tests. The steady-state performance data are summarized in Table XXI. The test variables were fuel film-coolant injection scheme (tangential or swirl), inlet pressures and inlet temperatures (ambient or cold). A typical thruster firing is shown in Figure 2.

The thruster performance (I_{spVAC}) is shown in Figure 63 for ambient temperature propellants using the tangential fuel film-coolant (FFC) injection scheme. Data for both the heat sink and thin-wall chambers are included. There is no difference in performance between the chambers as expected. Also, included for comparison is the Equilibrium One Dimensional (ODE) I_{spVAC} prediction. The I_{sp} efficiency at the design mixture ratio of 1.8 is about 90% which is close to that predicted with 25% fuel film-cooling. The thin-wall chamber performance using the swirl FFC injection is plotted in Figure 64 along with the tangential FFC data for comparison. There are no significant differences in performance due to the two FFC injection schemes. This is in agreement with the throat cooling results which show no significant difference. It is concluded that a significant amount of mixing of the film-coolant flow with the core flow must occur in the converging section of the nozzle, thus masking any differences between the two FFC injection schemes. This mixing is possibly due to the radial component of the fuel film coolant injection velocity.

TABLE XX

IGNITER OPERATING CONDITIONS - HEAT SINK CHAMBER TESTS

Test No.	P _O IV (psia)	P _F IV (psia)	Thruster		Igniter	Igniter	Igniter	Ignition
			P _c (psia)	P _c IGN (psia)	Δ P (psia)	Overall MR	Core MR	
120	342	269	129	158	39	1.0	14.4	Yes
121	381	270	141	186	45	1.28	17.5	Yes
122	377	273	140	186	46	1.25	17.1	Yes
123	361	273	141	185	44	1.20	16.2	Yes
124	343	277	148	188	40	1.08	15.4	Yes
125	335	275	149	183	34	1.02	14.7	Yes
126	343	271	149	198	49	1.15	16.9	Yes
127	341	180	127	170	43	3.00	44.5	Yes
128	344	365	159	206	47	0.831	11.4	Yes
129	203	261	104	130	26	0.557	7.3	Yes
130	203	168	95	121	26	0.844	12.1	Yes
131	473	379	190	262	72	1.25	18.3	Yes
132	481	288	177	245	68	2.14	30.8	Yes

Igniter Fuel Valve Lead = 10 msec
 Spark Energy = 50 MJ/SPK
 Spark Rate = 300 SPS

TABLE XXI

PERFORMANCE DATA SUMMARY - THIN WALL CHAMBER

Test No.	Duration (sec)	Data Period (sec)	FFC Injectors	PFTCV (psia)	POTCV (psia)	TFTCV (°F)	TOTCV (°F)	Pc (psia)	MP _E	W _T (lb/sec)	F _{vac} (lbf)	C* (ft/sec)	Isp _{vac} (sec)	"i C* (%)	"i Isp _v (%)
133	1.1	0.6/1.0	TANG	306	351	Amb	Amb	135.4	1.52	1.904	435.5	5148	228.7	91	88
134	1.1	0.6/1.0	TANG	310	372	Amb	Amb	140.4	1.64	1.988	452.1	5110	227.4	90	88
135	1.4	0.6/1.0	TANG	303	387	Amb	Amb	142.7	1.77	2.013	460.1	5130	228.5	91	89
136															
COMPUTER KILL															
137	5.1	0.6/1.0	TANG	301	203	Amb	Amb	90.8	0.778	1.485	287.9	4427	193.9	95	91
138		4.0/5.0	TANG	299	221	Amb	Amb	95.2	0.869	1.537	306.0	4482	199.0	91	88
139	2.0	0.6/1.0	TANG	184	226	Amb	Amb	91.4	1.31	1.282	291.6	5159	227.5	92	88
		1.0/1.87	TANG	184	226	Amb	Amb	90.8	1.31	1.284	291.8	5105	227.2	91	88
140	1.2	0.6/1.05	TANG	188	368	Amb	Amb	112.8	2.54	1.714	384.5	4764	224.3	89	92
141	1.7	0.6/1.0	TANG	428	372	Amb	Amb	150.7	1.26	2.186	482.2	4991	220.6	89	86
142	1.2	0.6/1.0	TANG	429	547	Amb	Amb	191.4	2.04	2.716	622.5	5100	229.2	93	91
143	1.0	0.6/0.9	TANG	309	546	Amb	Amb	172.5	2.71	2.515	565.5	4925	224.9	88	93

Ambient Propellants (T₀ = 60 - 70°F, T_F = 60 - 70°F)

FFC = 26%

TABLE XXI (cont.)

PERFORMANCE DATA SUMMARY - THIN WALL CHAMBER

Test No.	Duration (sec)	Data Period (sec)	FFC Injectors	PFTCV (psia)	POTCV (psia)	TFTCV (°F)	TOTCV (°F)	PFJ (psia)	POJ (psia)	Pc (psia)	MR _E	M _T (lb/sec)	F _{vac} (lbf)	C* (ft/sec)	I _{sp vac} (sec)	I _{sp v} (%)	
148	0.0	-	Swirl			Amb	Amb										
149	5.0	-	"			Valve Not Fully Opened (No Reduction)											
150	0.0	-	Computer Kill														
151	1.319	.6-1.32	Swirl	326	442			-	256	150.2	1.83	2.137	489.4	5088	229.0	91	90
152	0.41	-	"														
153	1.541	1.0-1.54	"	326	417			-	242	144.5	1.70	2.064	470.5	5067	228.0	90	89
154	0.0	-	"														
155	1.337	.6-1.34	"	207	359			-	208	116.9	2.10	1.660	381.6	5097	229.9	93	92
156	3.643	3.0-3.64	"	206	240			-	143	90.9	1.22	1.357	295.8	4845	217.9	87	86
157	5.000	4.0-5.0	"	318	242			-	147	98.8	0.89	1.593	318.6	4487	200.0	89	88
158	0.973	.6-.97	"	329	624			-	351	181.3	2.86	2.668	595.5	4917	223.2	94	93
159	1.018	.6-1.02	"	457	608			-	345	196.6	2.07	2.838	641.0	5013	225.9	91	90
160	1.713	1.0-1.71	"	447	437			-	257	159.4	1.41	2.336	517.6	4938	221.6	87	86
172	1.62	1.0-1.62	"	302	347	-5	-94	-	211	135.4	2.33	1.994	441.9	4915	221.6	91	90
173	1.48	1.0-1.48	"	192	341	21	-102	-	203	115.7	3.29	1.844	381.9	4543	207.1	89	89
174			"														
175	5.00	1.0-2.0	"	179	193	-129	-125	-	116	73.9	1.58	1.284	238.5	4170	185.5	74	72
176	5.00	2.0-3.0	"	286	183	-156	-126	-	113	78.8	1.24	1.360	256.1	4192	188.3	75	74
177	1.78	1.0-1.78	"	399	345	-146	-131	-	211	141.8	1.90	2.173	462.7	4724	212.9	85	84
178	1.16	.6-1.14	"	349	497	-137	-149	-	301	182.5	3.29	2.865	507.0	4608	208.2	90	90
179	1.25	.6-1.23	"	471	460	-141	-133	-	286	187.7	2.23	2.753	606.9	4935	220.5	91	89

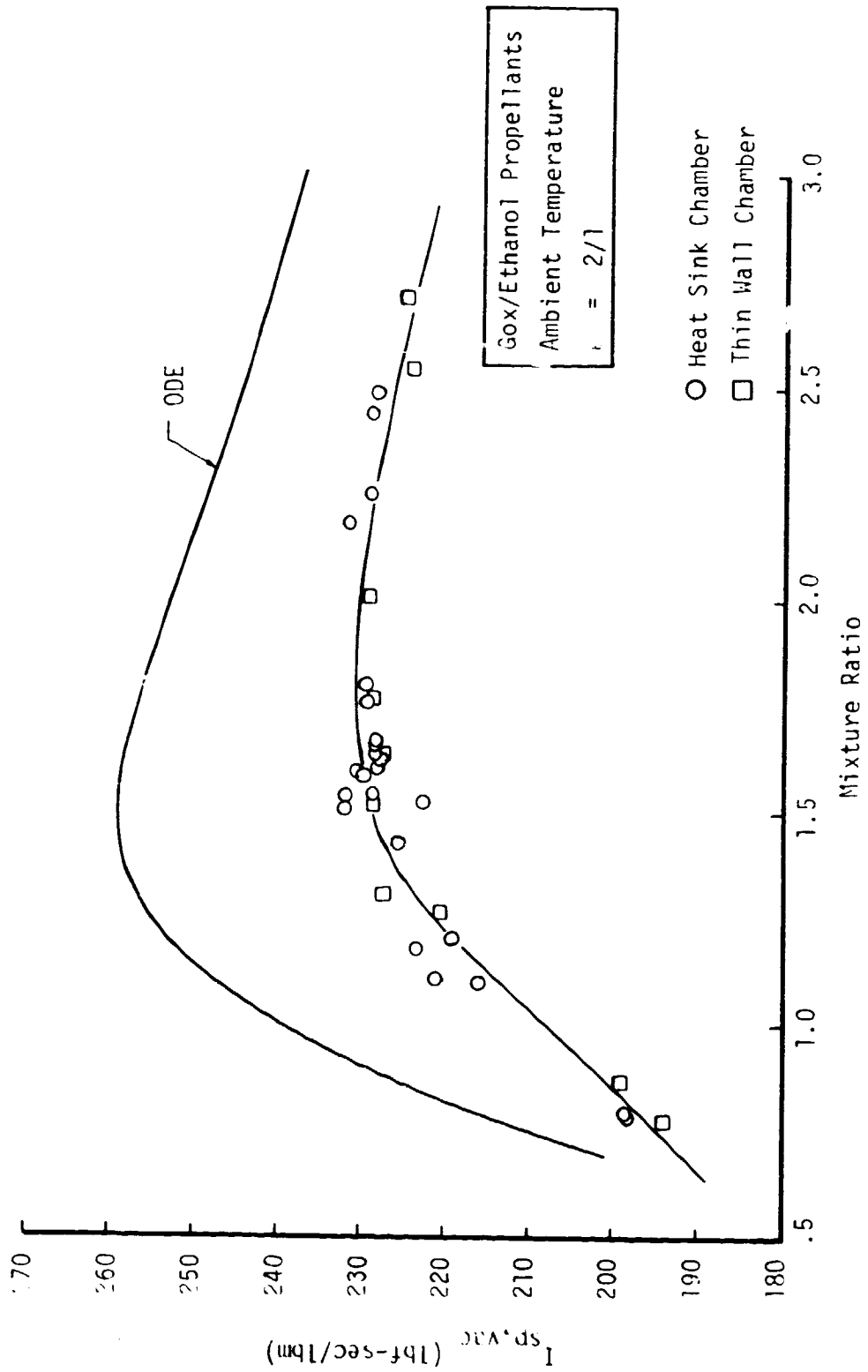

Figure 63. Thruster Isp Performance - Tangential FFC

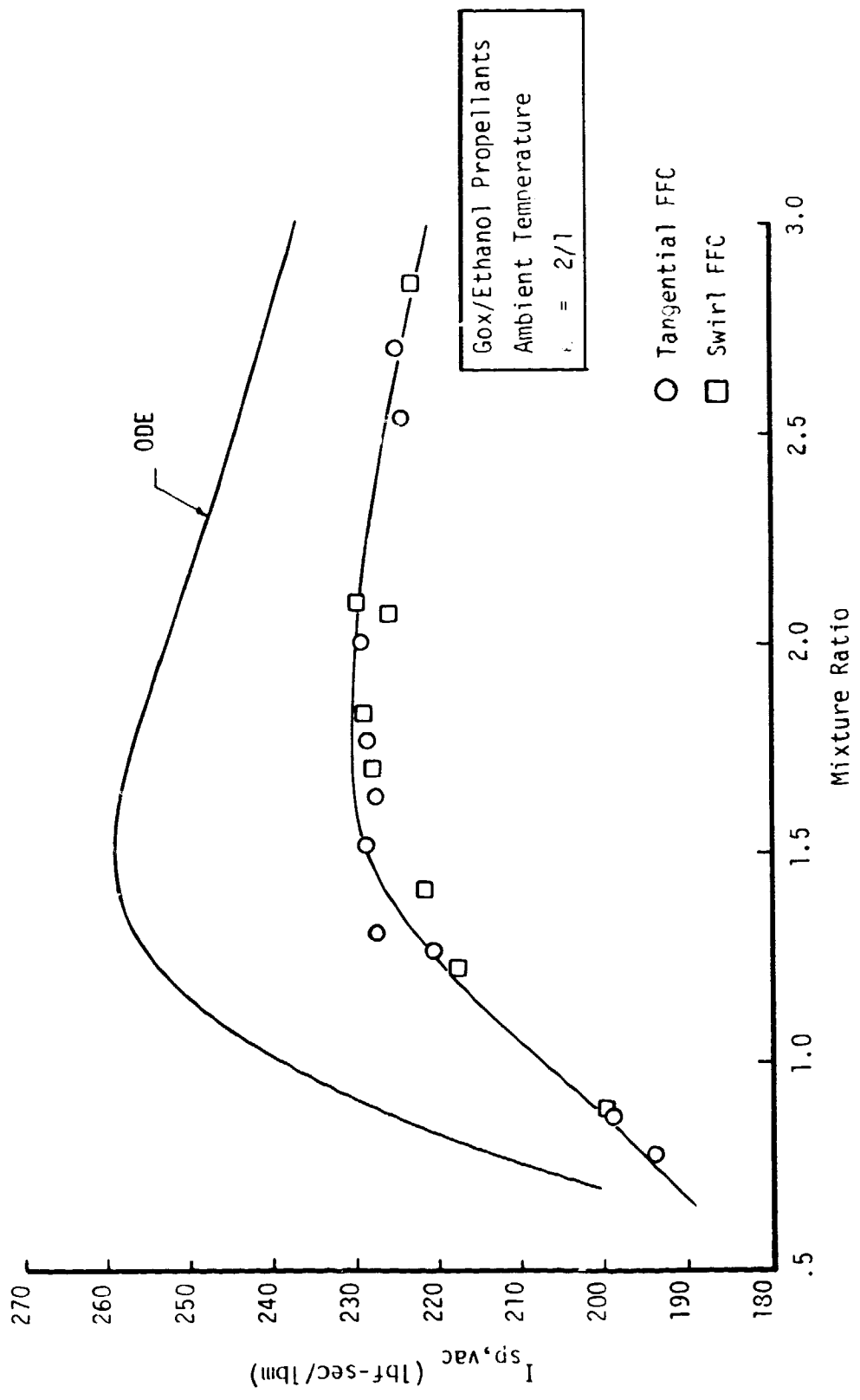

Figure G4. Thruster Isp Performance - Tangential and Swirl FFC

IV, C, Data Analysis (cont.)

The cold propellant performance (I_{spVAC}) data are plotted versus mixture ratio in Figure 65. The ambient performance data are included for comparison. The cold propellant reduces the performance by about 6% at the nominal operating conditions which is in agreement with earlier cold propellant testing (Reference 5). The C^* and I_{sp} efficiency data for the thin-wall chamber are summarized in Figure 8.

The thin-wall chamber backside thermocouples were instrumented to provide automatic engine shutdown if any temperature exceeded $1700^{\circ}F$. Most of the tests were terminated between 1 and 2 seconds duration by the temperature kill. Only the low P_c , low MR cases ran for a full 5 seconds duration. Typical throat wall temperature data are shown in Figure 66 for the nominal operating condition (Test 135) using tangential FFC. Axial chamber wall temperature profiles for the nominal operation condition (Test 135) are shown in Figure 67. The upstream wall temperatures are substantially cooler than the throat as expected. The hottest location is in the throat. Posttest examinations showed no evidence of streaking or hot spots in the cylindrical section of the chamber. Minor streaking was evident in the throat at the T-180 location. Post test examination showed reduced FFC flows which would explain T-180 being the hottest location. The same condition were observed with the swirl FFC.

Thermal analyses of the swirl FFC thermocouple data were made to predict the adiabatic wall temperatures to define the amount of fuel film-cooling required for a flight engine. The results are shown in Figure 68. The analysis shows that approximately 40% FFC would be required for this engine length and injector pattern. Smaller amounts of FFC may be adequate if a pure axial FFC injection scheme were used (no radial velocity component).

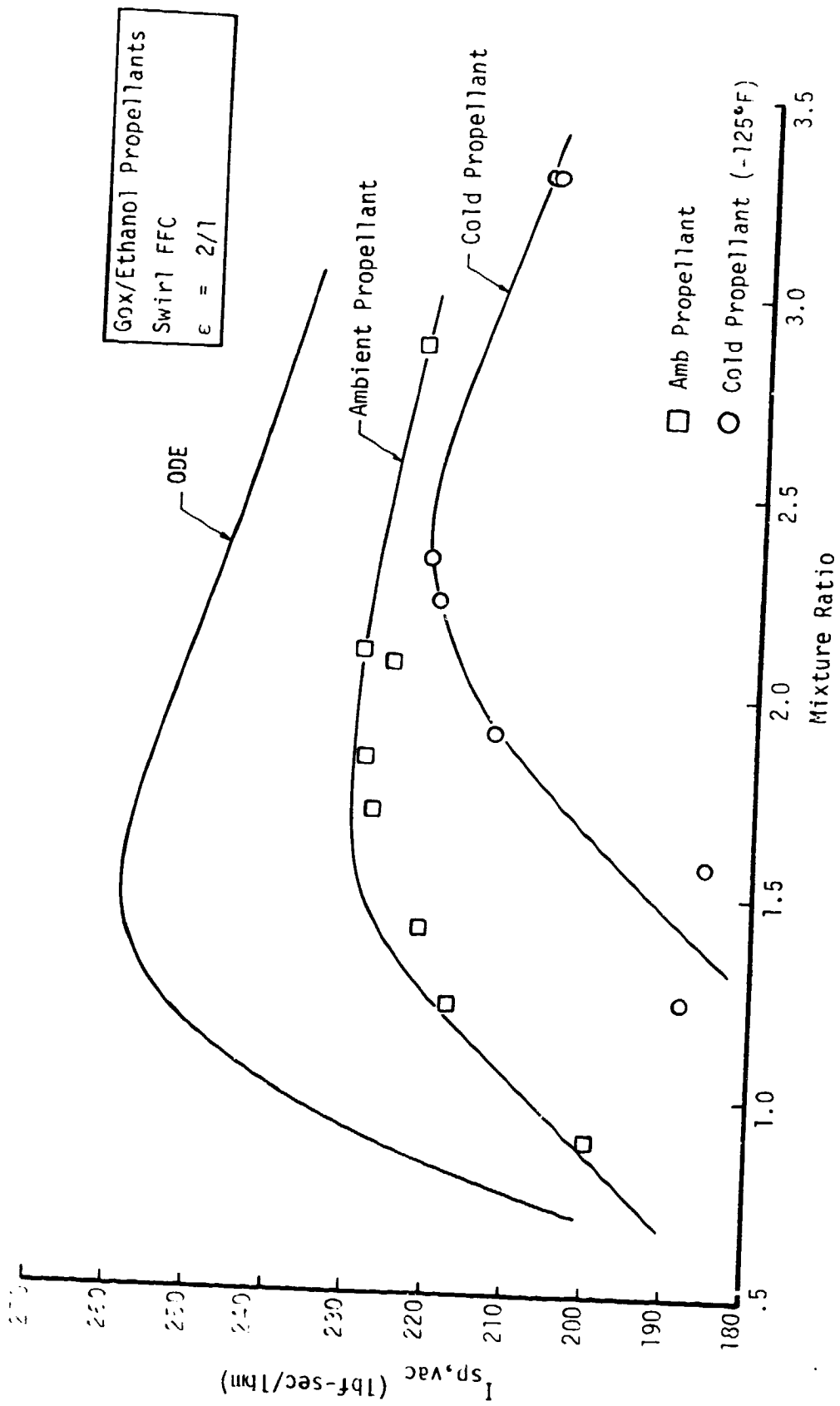

Figure 65. Thruster Isp Performance - Ambient and Cold Propellant

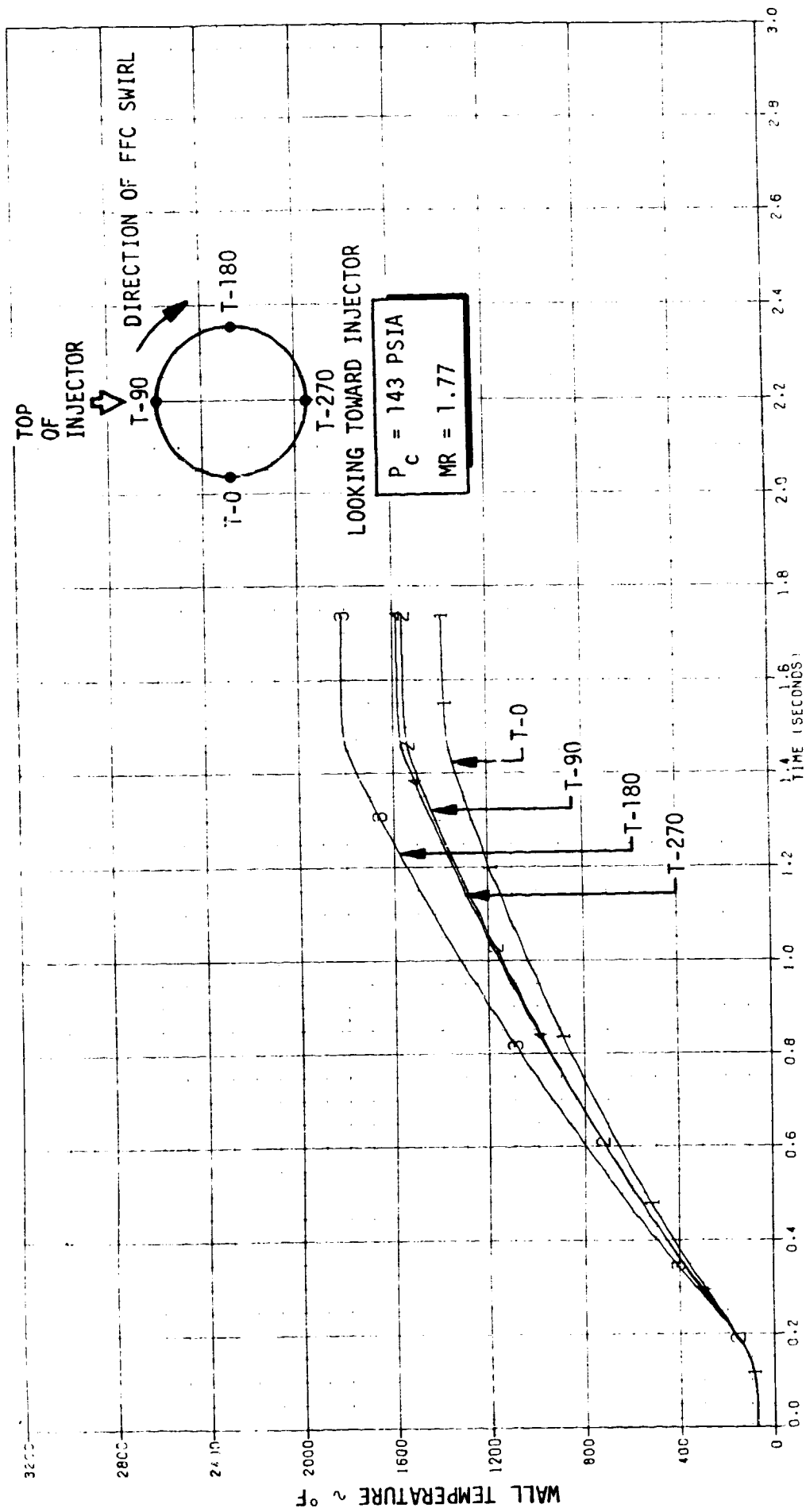
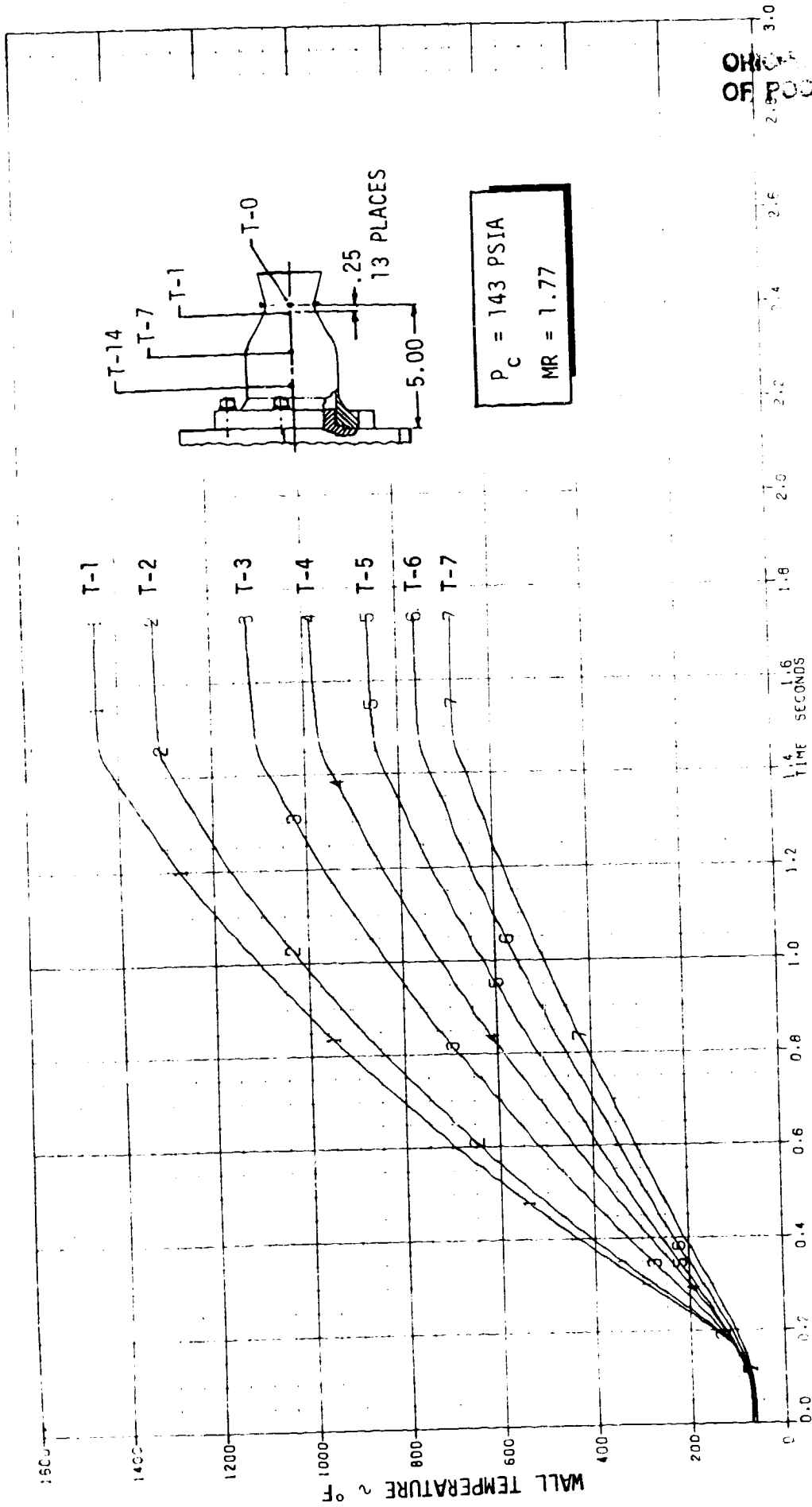

Figure 66. Throat Wall Temperature History - Tangential FFC (Test 135)



OHIO STATE UNIVERSITY
 DEPARTMENT OF MECHANICAL ENGINEERING

Figure 57. Thruster Wall Temperature Profiles - Tangential FFC (Test 135)

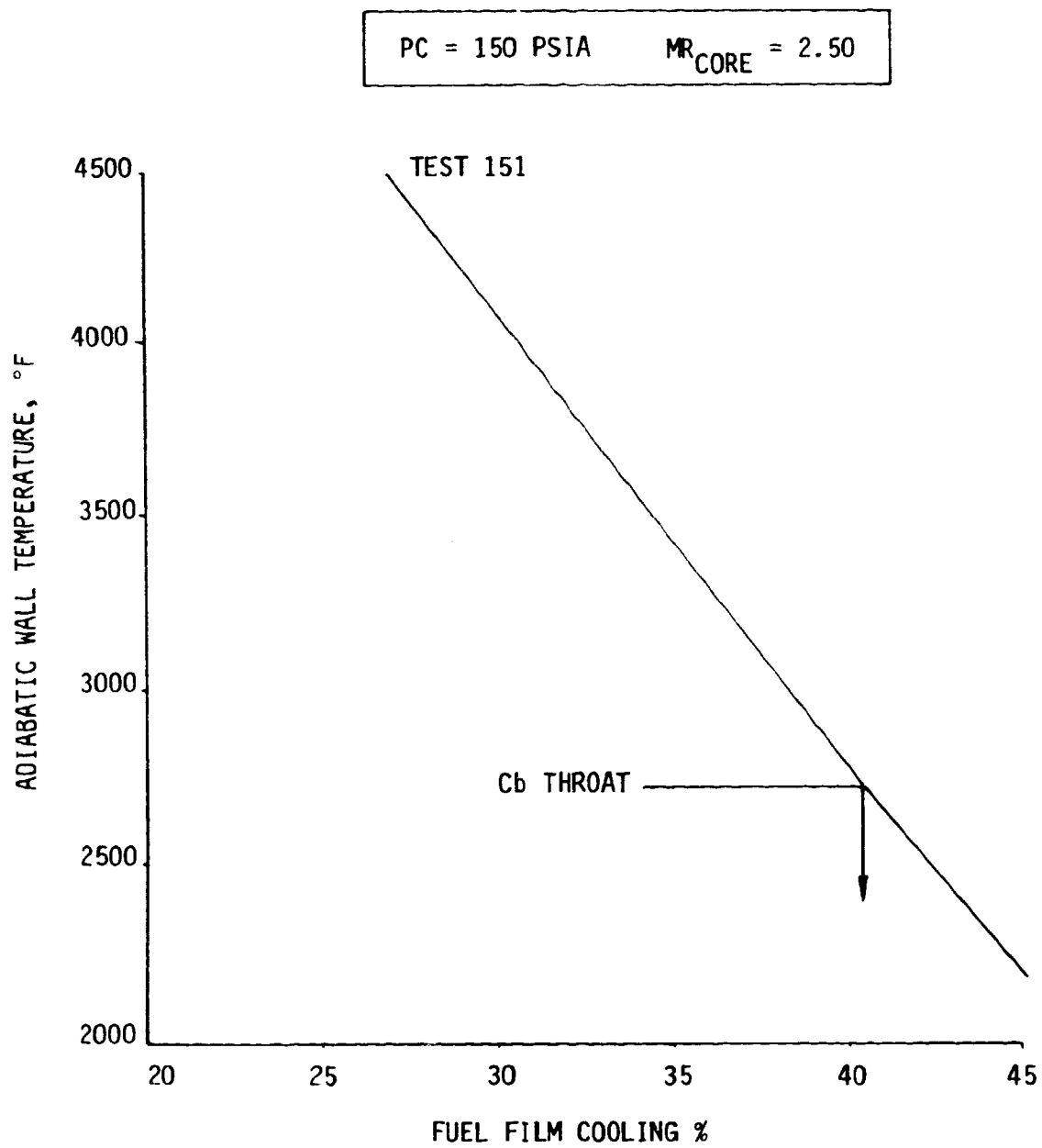

Figure 68. Effect of Fuel Film Cooling on Predicted Thruster Adiabatic Wall Temperature

IV, C, Data Analysis (cont.)

Examination of the high frequency data show unorganized combustion noise levels of 5-6% of P_c . No organized oscillations were observed. Post-test examination of the hardware showed it to be clean with no evidence of thermal incompatibility. The exhaust plumes were observed to be clear with no evidence of carbon formation.

An oscillograph trace of a typical pulse sequence is shown in Figure 10. The pulse performance data are summarized in Table XXII. The test variables were valve actuation (GN_2 or GHe), pulse width (valve open to valve close), inlet pressures and inlet temperature (ambient or cold). The first four (4) pulse tests were run with a GN_2 driven actuator. The remaining tests used a GHe driven actuator to speed the valve opening and closing times.

Thruster bit/impulse and bit I_{sp} are plotted versus pulse width (valve open to valve close) in Figures 69-71, for both the GN_2 and GHe actuated valves at the thruster nominal inlet pressures and ambient temperatures. The small impulse bits could only be achieved with the faster GHe driven valve. Thruster bit I_{sp} is plotted versus mixture ratio in Figure 70 for a pulse width of 0.080 sec using the GHe driven valve. Cold propellant pulse performance data are plotted in Figures 71 and 72. The cold propellant data show much greater dispersion than the ambient temperature data due to inlet temperature variations. The bit impulse and I_{sp} are lower than for the ambient temperature propellants as expected.

TABLE XXII

PULSE PERFORMANCE DATA SUMMARY

Test No.	EPW (sec)	Pulse Width (sec)	Coast (sec)	Valve Actuation	PFTCV (psia)	POTCV (psia)	TFTCV (°F)	TOTCV (°F)	PC (psia)	MRE	Bit Impulse (lb-sec)	W _T (lb)	Bit Isp (sec)
144	0.251	0.381	-	GN ₂	310	370	Amb	Amb	151	1.36	153.9	0.708	217.4
145	0.340	0.472	-	GN ₂	311	370	Amb	Amb	155	1.38	191.8	0.806	223.1
146	0.110	0.238	-	GN ₂	312	385	Amb	Amb	155	1.35	92.0	0.439	209.7
147	0.050	0.178	-	GN ₂	313	395	Amb	Amb	159	1.32	60.3	0.327	184.4
161(1)	.260	.200	.943	GHe	308	435	Amb	Amb	-	-	-	-	*
(2)	.207	.158	.943	GHe	318	426	Amb	Amb	147.5	1.72	60.3	.340	177.1
(3)	.183	.130	.940	GHe	315	430	Amb	Amb	146.3	1.76	51.4	.304	169.0
(4)	.165	.106	.936	GHe	313	428	Amb	Amb	144.3	1.77	41.3	.259	159.7
(5)	.140	.085	.941	GHe	316	432	Amb	Amb	146.6	1.73	33.8	.209	162.2
(6)	.114	.055	.936	GHe	328	428	Amb	Amb	146.1	1.75	21.3	.150	142.0
(7)	.095	.039	-	GHe	338	426	Amb	Amb	142.3	1.72	15.2	.119	127.0
162(1)	.265	.204	.936	GHe	315	435	Amb	Amb	147.5	1.79	80.8	.452	178.7
(2)	.210	.155	.941	GHe	310	460	Amb	Amb	148.0	1.84	62.5	.365	171.1
(3)	.189	.128	.839	GHe	320	439	Amb	Amb	147.8	1.81	53.0	.317	167.2
(4)	.162	.106	.938	GHe	320	442	Amb	Amb	148.0	1.81	43.0	.364	162.5
(5)	.138	.085	.942	GHe	318	445	Amb	Amb	147.5	1.82	33.9	.320	154.4
(6)	.108	.055	.941	GHe	315	440	Amb	Amb	147.4	1.82	21.3	.154	138.0
(7)	.098	.041	-	GHe	330	432	Amb	Amb	146.2	1.78	15.7	.123	128.0
163(1)	.142	.081	.938	GHe	196	435	Amb	Amb	125.0	2.80	24.3	.165	147.3
(2)	.142	.083	-	GHe	198	433	Amb	Amb	125.0	2.75	27.1	.182	148.4
164(1)	.140	.081	.940	GHe	201	269	Amb	Amb	96.1	1.40	18.2	.118	4.3
(2)	.140	.082	-	GHe	195	261	Amb	Amb	93.7	1.44	19.5	.130	143.2
165(1)	.145	.080	.936	GHe	305	262	Amb	Amb	102.3	0.97	19.7	.134	147.0
(2)	.140	.084	-	GHe	308	258	Amb	Amb	101.1	0.94	21.3	.159	133.8
166(1)	.140	.083	.940	GHe	315	610	Amb	Amb	177.5	2.73	39.1	.247	158.4
(2)	.144	.081	-	GHe	320	608	Amb	Amb	175.1	2.68	41.3	.264	156.4

TABLE XXII (cont.)

PULSE PERFORMANCE DATA SUMMARY

Test No.	Env (sec)	Pulse width (sec)	Coast (sec)	Valve Actuation	PFTCV (psia)	POTCV (psia)	TFICV (%F)	TOTCV (°F)	PC (psia)	MVE	Bit Impulse (lb-sec)	WT (lb)	Bit Imp (sec)
167(1)	.140	.084	.944	GH _e	445	612	Amb	Amb	-	-	-	-	-
(2)	.136	.082	-	GH _e	450	606	Amb	Amb	195.3	2.04	46.4	.281	165.0
168(1)	.142	.084	.939	GH _e	433	432	Amb	Amb	26.3	1.23	6.7	.202	33.2
(2)	.137	.082	-	GH _e	440	425	Amb	Amb	155.9	1.40	36.4	.221	165.0
169(1)	.140	.082	.066	GH _e	305	432	Amb	Amb	-	-	-	-	-
(2)	.140	.100	.065	GH _e	320	430	Amb	Amb	144.3	1.75	37.5	.226	165.7
(3)	.140	.100	.070	GH _e	298	415	Amb	Amb	140.9	1.78	36.9	.225	163.7
(4)	.140	.099	.066	GH _e	302	430	Amb	Amb	143.1	1.81	37.0	.228	162.2
(5)	.140	.100	.065	GH _e	310	434	Amb	Amb	144.5	1.83	37.8	.234	161.6
(6)	.140	.100	.065	GH _e	305	435	Amb	Amb	142.6	1.84	38.1	.235	162.3
(7)	.140	.099	-	GH _e	305	432	Amb	Amb	141.8	1.87	38.7	.222	173.9
170(1)	.140	.084	.066	GH _e	301	442	Amb	Amb	-	-	-	-	-
(2)	.139	.100	.066	GH _e	310	431	Amb	Amb	143.7	1.76	37.2	.228	163.0
(3)	.139	.100	.067	GH _e	310	428	Amb	Amb	143.8	1.71	37.4	.227	164.6
(4)	.110	.070	.065	GH _e	305	410	Amb	Amb	141.9	1.69	25.3	.164	154.0
(5)	.110	.070	.065	GH _e	300	405	Amb	Amb	136.2	1.64	25.2	.153	164.7
(6)	.095	.055	.066	GH _e	300	402	Amb	Amb	136.1	1.63	18.7	.132	141.8
(7)	.096	.055	-	GH _e	30	410	Amb	Amb	136.7	1.65	19.0	.133	142.6
171(1)	.140	.084	.066	GH _e	311	442	Amb	Amb	-	-	-	-	-
(2)	.140	.099	.065	GH _e	335	435	Amb	Amb	145.2	1.78	37.5	.230	163.2
(3)	.140	.101	.068	GH _e	305	422	Amb	Amb	143.4	1.73	37.8	.229	165.2
(4)	.110	.069	.066	GH _e	308	412	Amb	Amb	136.1	1.71	25.2	.163	154.2
(5)	.110	.069	.066	GH _e	312	405	Amb	Amb	134.1	1.74	25.1	.157	159.8
(6)	.095	.054	.066	GH _e	290	396	Amb	Amb	133.2	1.62	18.6	.130	143.2
(7)	.095	.054	-	GH _e	286	392	Amb	Amb	131.0	1.60	18.6	.130	142.5

TABLE XXII (cont.)

PULSE PERFORMANCE DATA SUMMARY

Test No.	EPW (sec)	Pulse Width (sec)	Coast (sec)	Valve Actuation	PFTCV (psia)	POTCV (psia)	TFTCV (°F)	TOTCV (°F)	PC (psia)	MRE	Bit Impulse (lb-sec)	W _T (lb)	Bit Isp (sec)
180(1)	.140	.082	.059	GH _e	350	348	-2	-100	137	1.21	29.4	.303	97.0
(2)	.140	.102	.059	GH _e	345	350	-32	-99	159	1.37	28.3	.170	166.6
(3)	.140	.102	.060	GH _e	350	348	-61	-102	172	1.31	24.8	.164	151.3
(4)	.110	.072	.059	GH _e	335	347	-75	-105	149	1.32	24.0	.180	133.4
(5)	.110	.072	.059	GH _e	335	338	-91	-106	159	*	Data Reduction Program Error - No Data		
(6)	.095	.057	.058	GH _e	312	332	-99	-108	151	*			
(7)	.095	.057	-	GH _e	332	328	-102	-108	139	*			
181													
182(1)	.140	.084	.059	GH _e	209	214	No Ignition	-54	78.8	1.01	16.5	.124	133.4
(2)	.140	.102	.059	GH _e	202	210	-36	-49	87.5	1.01	20.2	.143	141.2
(3)	.140	.101	.059	GH _e	203	210	-55	-48	87.1	.99	20.3	.144	141.5
(4)	.109	.071	.059	GH _e	207	208	-93	-49	87.1	.97	14.1	.103	137.4
(5)	.109	.071	.059	GH _e	218	209	-102	-50	89.0	.98	14.7	.105	139.7
(6)	.095	.056	.058	GH _e	215	208	-103	-50	87.	.94	11.1	.084	132.2
(7)	.095	.057	-	GH _e	215	207	-105	-50	84.	.95	11.1	.084	132.6
183(1)	.140	.080	.059	GH _e	270	218	-32	-64	95.	.839	19.0	.142	134.1
(2)	.140	.102	.059	GH _e	260	215	-61	-60	94.7	.839	22.3	.160	139.7
(3)	.140	.101	.059	GH _e	275	212	-91	-58	94.5	.829	22.5	.160	140.1
(4)	.109	.071	.059	GH _e	265	211	-97	-59	95.6	.812	15.4	.114	135.8
(5)	.110	.071	.059	GH _e	255	210	-101	-60	93.7	.833	15.6	.108	143.5
(6)	.095	.057	.059	GH _e	255	208	-104	-60	91.1	.819	11.9	.091	130.8
(7)	.095	.057	-	GH _e	258	209	-105	-60	90.3	.836	12.1	.096	125.4
184(1)	.140	.081	.059	GH _e	275	274	-37	-74	109.8	1.03	20.3	.134	151.6
(2)	.140	.102	.059	GH _e	269	272	-67	-69	108.6	1.08	27.5	.177	155.1
(3)	.140	.102	.059	GH _e	262	265	-92	-69	109.0	1.10	27.6	.177	155.8
(4)	.109	.071	.059	GH _e	260	264	-96	-69	107.6	1.11	19.0	.125	151.7
(5)	.109	.071	.059	GH _e	253	265	-101	-70	106.0	1.10	18.6	.127	145.9
(6)	.095	.055	.060	GH _e	252	266	-106	-70	104.5	1.08	14.9	.103	144.7
(7)	.095	.055	-	GH _e	264	263	-108	-70	106.0	1.14	14.5	.106	136.8

ORIGINAL DATA OF POOR QUALITY

*Igniter Ox Valve Malfunction

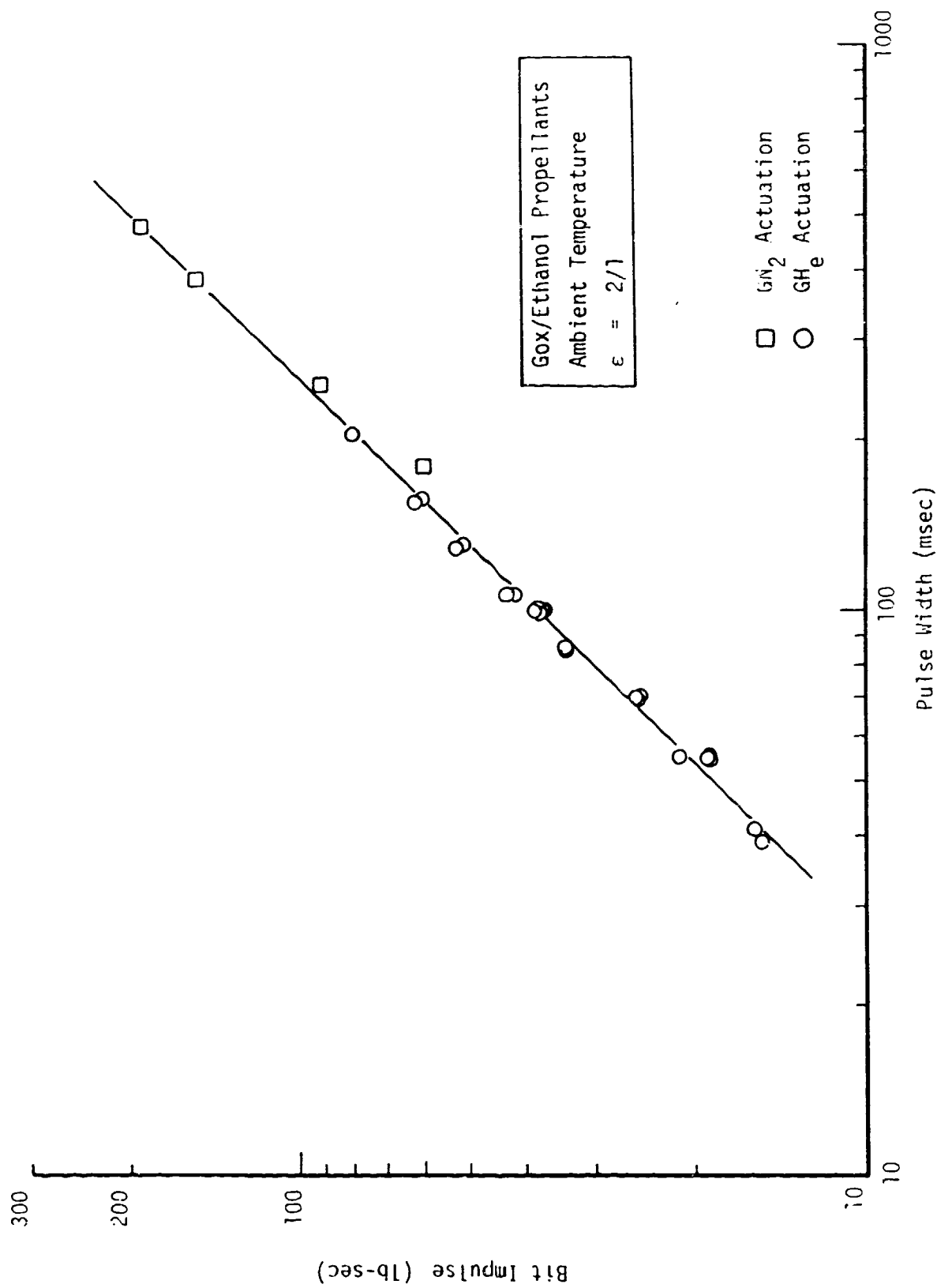

Figure 69. Effect of Pulse Width on Bit Impulse - Nominal Inlet Pressures

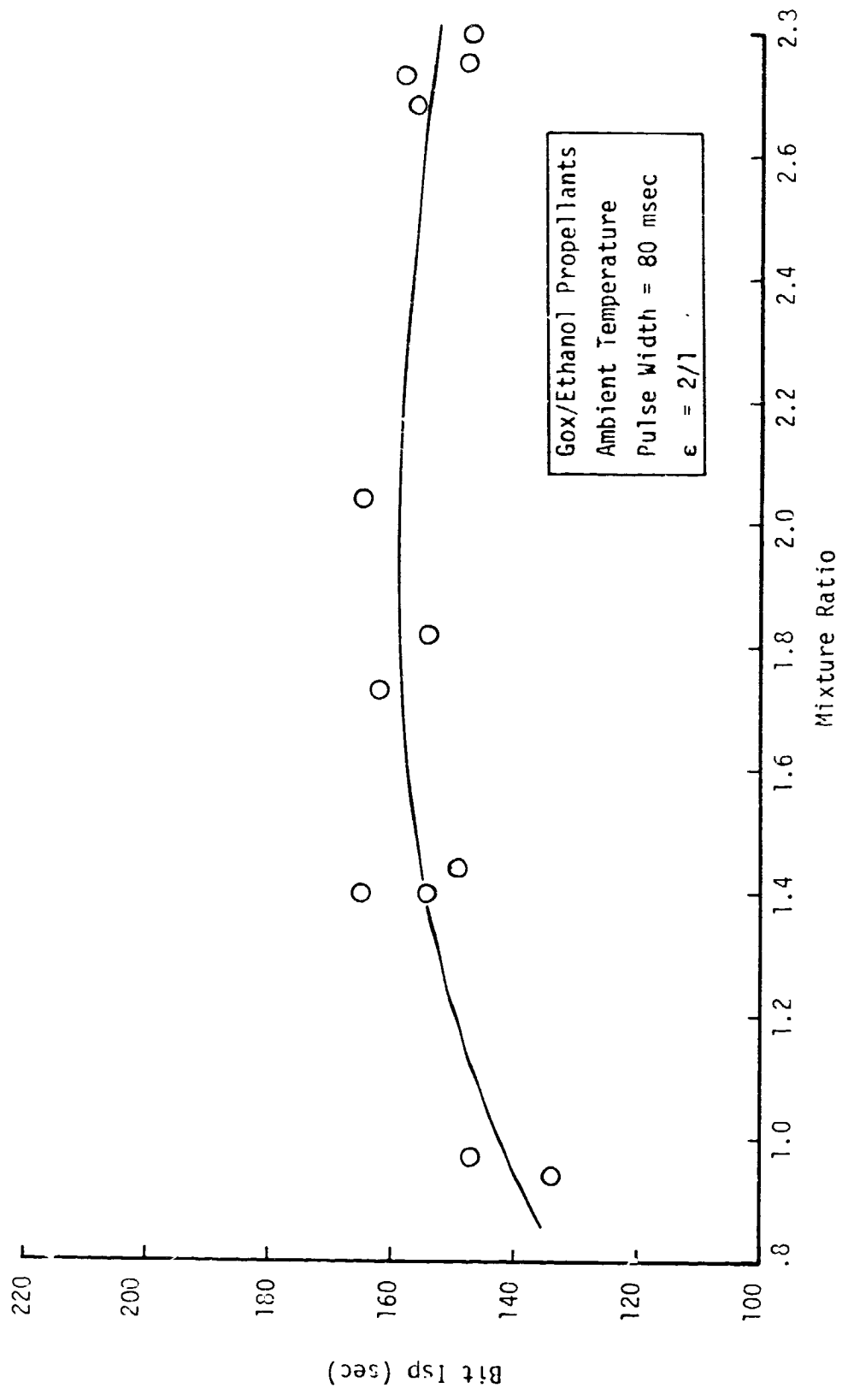

Figure 70. Effect of Inlet Pressures (MR) on Bit Isp

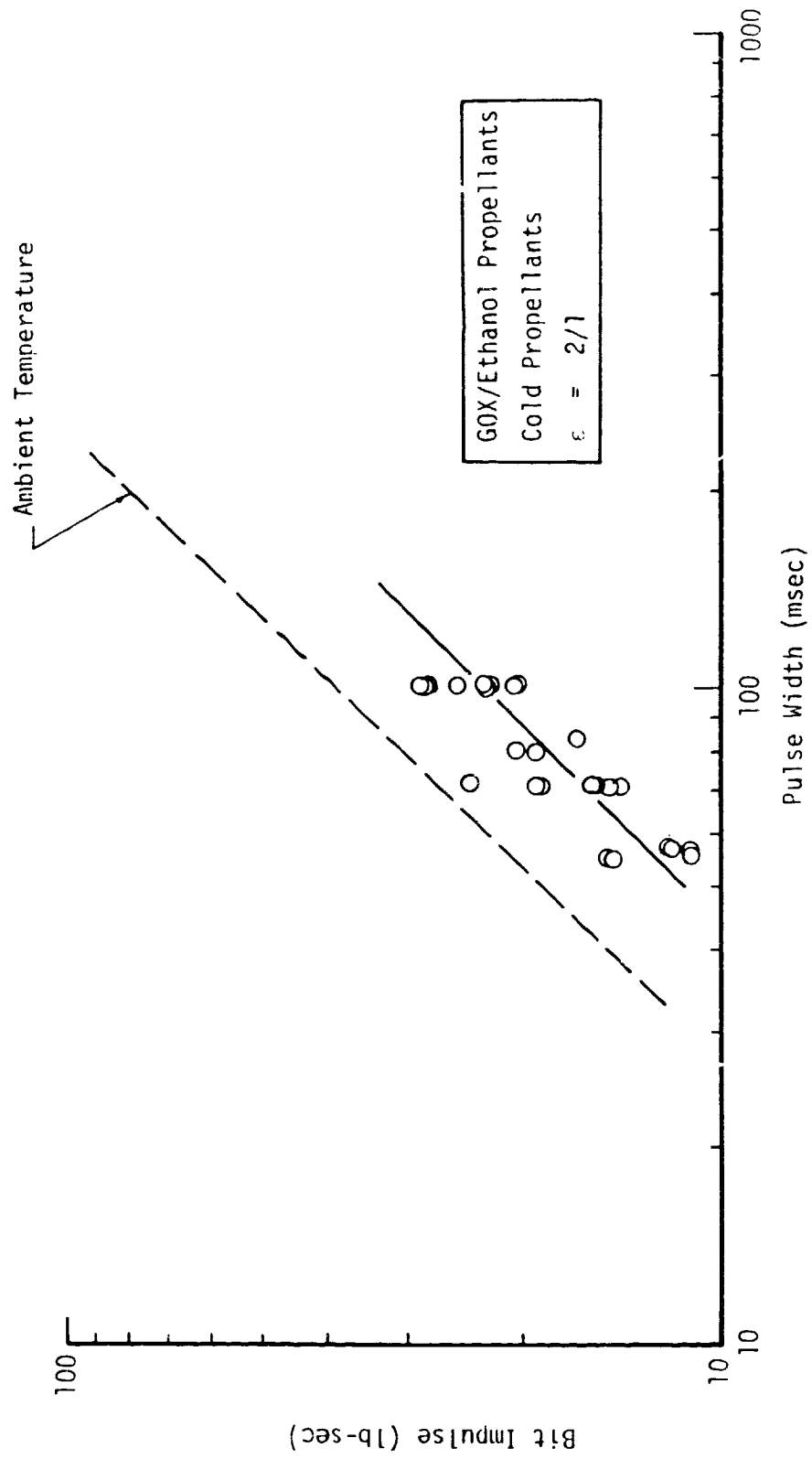

Figure 71. Effect of Pulse Width on Bit Impulse - Cold Propellants

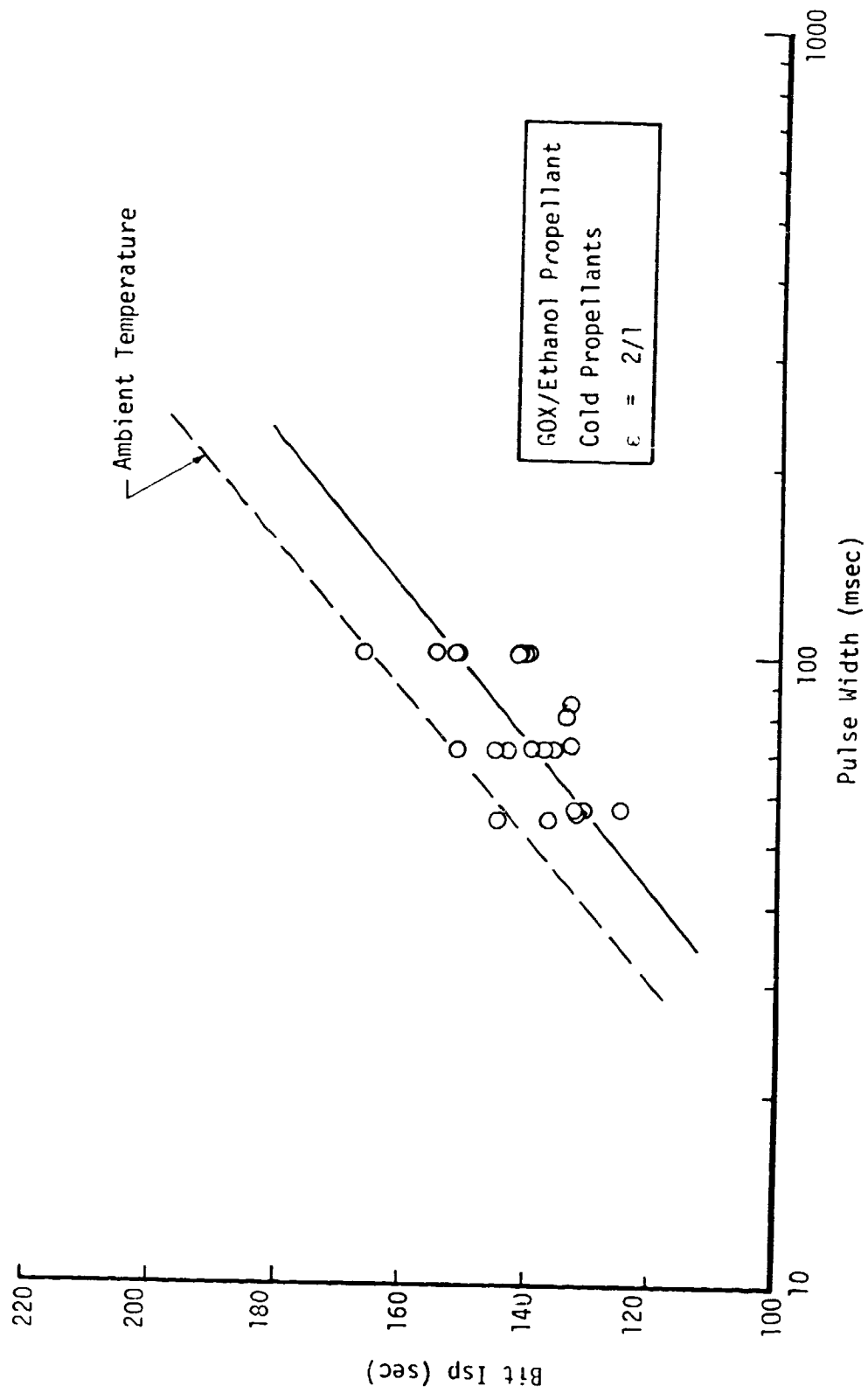

Figure 72. Effect of Pulse Width on Bit Isp - Cold Propellants

REFERENCES

1. Michel, R. W., "Combustion Performance and Heat Transfer Characterization of LOX/Hydrocarbon Type Propellants," Final Report, Contract NAS 9-15859, April 1983, Aerojet TechSystems Company.
2. G. F. Orton, T. D. Mark, D. D. Weber, "LOX/Hydrocarbon Auxiliary Propulsion System Study," Contract NAS 9-16305, Report MDC E2548, McDonnell Douglas Astronautics, St. Louis Division, July 1982.
3. Lawver, B. R., "Ignition Characterization of LOX/Hydrocarbon Propellants," Task I Data Dump, Contract NAS 9-16639, June, 1983, Aerojet TechSystems Co.
4. Lawver, B. R., "Ignition Characterization of LOX/Hydrocarbon Propellants," Task II Data Dump, Contract NAS 9-16639, February 1983, Aerojet Techsystems Co.
5. Lawver, B. R., "Ignition Characterization of LOX/Hydrocarbon Propellants," WBS 8.0 Data Dump, Contract NAS 9-16639, May 1983, Aerojet TechSystems Co.
6. Lawver, B. R., "Ignition Characterization of LOX/Hydrocarbon Propellants," Task III Data Dump, Contract NAS 9-16639, August 1984, Aerojet TechSystems Co.

END

DATE

FILMED

AUG 20 1985