

N85-29238

RELATIONSHIP BETWEEN ALLAN VARIANCES AND KALMAN FILTER PARAMETERS

A. J. Van Dierendonck

J. B. McGraw

Stanford Telecommunications, Inc.

Santa Clara, CA 95054

and

R. Grover Brown

Electrical Engineering and Computer Engineering Department

Iowa State University

Ames, Iowa 50011

ABSTRACT

In this paper we construct a relationship between the Allan variance parameters (h_2 , h_1 , h_0 , h_{-1} and h_{-2}) and a Kalman Filter model that would be used to estimate and predict clock phase, frequency and frequency drift. To start with we review the meaning of those Allan Variance parameters and how they are arrived at for a given frequency source. Although a subset of these parameters is arrived at by measuring phase as a function of time rather than as a spectral density, they all represent phase noise spectral density coefficients, though not necessarily that of a rational spectral density.

The phase noise spectral density is then transformed into a time domain covariance model which can then be used to derive the Kalman Filter model parameters. Simulation results of that covariance model are presented and compared to clock uncertainties predicted by Allan variance parameters. A two state Kalman Filter model is then derived and the significance of each state is explained.

C-4

INTRODUCTION

The NAVSTAR Global Positioning System (GPS) has brought about a challenge -- the challenge of modeling clocks for estimation processes. The system is very reliant on clocks, since its navigation accuracy is directly related to clock performance and the ability to estimate and predict time.

The estimation processes are usually in the form of Kalman Filters, or variations thereof such as Square Root Information Filters. These filters range from the large Ephemeris Determination Filter in the Control Segment, to Navigation Filters in the User Equipment, to Positioning Filters for stationary positioning or for merely solving for time and frequency in a Time Transfer system. In all of these applications, clock states and thus clock models exist. Not all of the models are necessarily proper.

It is the purpose of this paper to shed some light on how to model clocks for Kalman Filters. The presentation of clock statistics as Allan Variances has frustrated systems engineers for some time now because they don't know how to interpret them or how they can be used to predict system performance. The problem is even compounded because flicker noise is not a rational process.

In the past, Dr James Barnes ^(1,2) and Dave Allan ⁽¹⁾ had shed some light on the clock modeling problem, although some of it was well in the past (1966)⁽¹⁾. For some young modern day engineers, this work is hidden in old IEEE proceedings and NBS Technical Notes. Here, we are going to resurrect some of that work and form it into Kalman Filter models, but not without problems because of the flicker noise phenomenon.

Review of the Allan Variance Parameters

The Allan Variance parameters of an oscillator or atomic frequency standard are based on measurements of phase differences between that oscillator or atomic standard and a reference standard (which may be a low phase noise crystal oscillator for short term - high frequency measurements). These measurements are processed in two ways -- spectral analysis for higher frequency phase noise and time domain analysis for the relatively low

frequency variations. The single sided phase noise spectral density is converted to a single-sided spectral density of fractional frequency fluctuation of the form (3)

$$S_y(f) = h_2 f^2 + h_1 f + h_0 + h_{-1}/f + h_{-2}/f^2 ; f_1 \leq f \leq f_h \quad 1)$$

where f_1 and f_h define the measurement system noise bandwidth, and where the h_a coefficients represent the following processes:

- h_2 - white phase noise
- h_1 - flicker phase noise
- h_0 - white frequency noise
- h_{-1} - flicker frequency noise
- h_{-2} - random walk frequency noise

Normally the spectral density of equation 1 is obtained from a combination of the measured single-sided phase noise spectral density in radians/squared/Hz by

$$S_y(f) = \frac{f^2}{f_0^2} S_\phi(f) \quad 2)$$

for a nominal frequency f_0 , and from the square root of the Allan two-sample variances, $\sigma_y(\tau)$, which are computed as (3)

$$\sigma_y^2(\tau) = \frac{(\bar{y}_{k+1} - \bar{y}_k)^2}{2} \quad 3)$$

$$\approx \frac{1}{2(M-1)} \sum_{k=1}^{M-1} (\bar{y}_{k+1} - \bar{y}_k)^2 \quad 4)$$

where $\langle \rangle$ is the expected value operator and

$$\bar{y}_k = \frac{1}{\tau} \int_{t_k}^{t_k + \tau} y(t) dt = \frac{\phi(t_k + \tau) - \phi(t_k)}{2\pi f_0 \tau} \quad 5)$$

where $\phi(t_k)$ are the measurements of the phase differences mentioned earlier.

When plotted, $\sigma_y(\tau)$, as shown in Figure 1, has the form (3)

$$\sigma_y^2(\tau) = \frac{h_0}{2} \tau^{-1} \quad 6)$$

$$\sigma_y^2(\tau) = (2 \ln 2) h_{-1} \quad 7)$$

$$\sigma_y^2(\tau) = \frac{(2\pi)^2}{6} h_{-2} \tau \quad 8)$$

for white, flicker and random frequency noises, respectively. In this paper we will only consider those three processes in the time domain for the Kalman Filter model. However, the white and flicker phase noises will be considered later in the model of the Kalman Filter measurement noise.

As can be seen, the h_α parameters can be obtained from two sources -- the single-side band (SSB) phase noise plot of a specification of an oscillator or frequency standard and its stability specification, which is given in terms of the Allan two-sample standard deviation. The SSB phase noise spectrum is usually given in dBc/Hz, or

$$S_\phi(f) = 20 \log f_0 + 10 \log [h_2 + h_1/f + h_0/f^2 + h_{-1}/f^3 + h_{-2}/f^4] \quad 9)$$

Also of interest in later discussions is the spectral density of time fluctuation $x(t)$ in seconds, where

$$x(t) = \phi(t)/2\pi f_0 \quad 10)$$

so that

$$\begin{aligned} S_x(f) &= \frac{1}{(2\pi f_0)^2} S_\phi(f) \\ &= \frac{1}{(2\pi)^2} [h_2 + h_1/f + h_0/f^2 + h_{-1}/f^3 + h_{-2}/f^4] \end{aligned} \quad 11)$$

in seconds squared per Hz.

ORIGINAL PAGE IS
OF POOR QUALITY

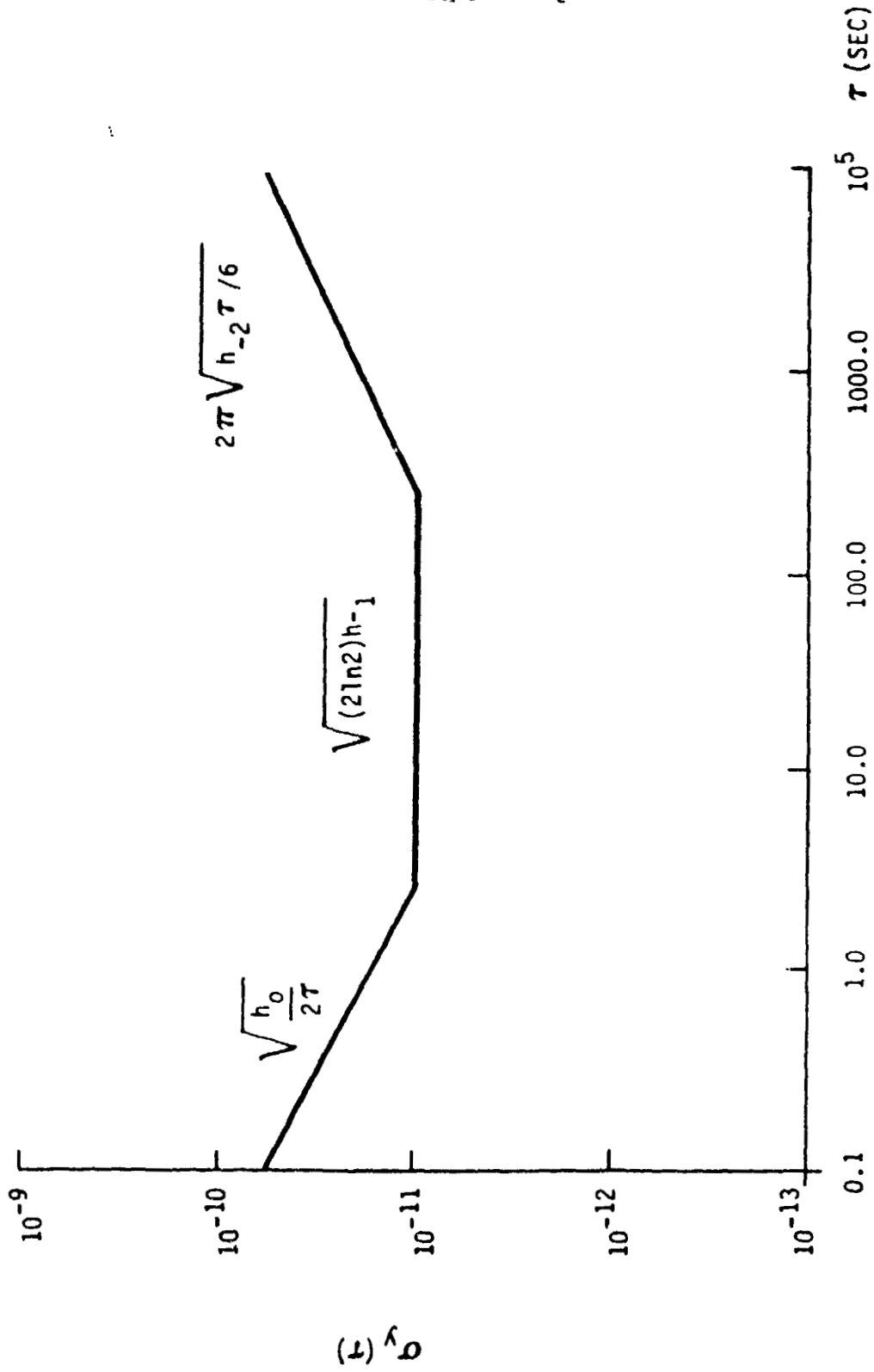

FIGURE 1 $\sigma_y(\tau)$ OF A TYPICAL FREQUENCY SOURCE

Transformation to a Statistical Covariance Model

Here, the work of Barnes and Allan (1) is expanded a bit to develop a covariance model that at least provides an "uncertainty" model one might use in a Kalman Filter.* An "uncertainty" model is defined here as one that has the variance propagation characteristics of a process, although the time autocorrelation properties may be wanting. This is not unusual in modeling for a Kalman Filter where large size state models are not feasible or when the process is not truly a definable stochastic process. For example, if we were to model position and velocity of a navigator in 6 states, where any acceleration excursions are considered an uncertainty in the change in position and velocity, that uncertainty is certainly not a "white noise" process by any means.

Barnes and Allan only addressed the statistical model of flicker frequency noise. However, the models for white and random walk frequency noise are straightforward. Just in brief, they derived a convolution integral that related the phase fluctuation due to flicker frequency noise to white noise,

where

$$z(t) = \int_0^t h(t-u)\eta(u)du \quad 12)$$

where $h(t)$ is an impulse response of a transfer function and $\eta(t)$ is a white noise process. The secret is in the derivation of that impulse response, which they did for the flicker noise. To provide a more general derivation of that impulse response, let us back up a bit.

A theoretical definition of a white noise spectral density is a constant, such as the h_0 in equation 1. If it is possible, another spectral density can be related to a white noise spectral density as

*For a tutorial on Kalman Filter Models, refer to Reference 4 by R. G. Brown, which is the previously presented paper in this meeting.

$$\begin{aligned}
 S_z(\omega) &= |H(j\omega)|^2 S_w(\omega) \\
 &= |H(j\omega)|^2
 \end{aligned}
 \tag{13}$$

where we define the white noise density to be unity. Let us do that for the h_0 , h_{-1} and h_{-2} processes defined in equations 1 and 11, converting first to fractional frequency squared/radians/second and seconds squared/radians/second, and then to a two sided spectral density S' . Then,

$$S_{iy_0}(\omega) = h_0/2 \quad (\text{white frequency noise}) \tag{14}$$

$$S_{iy_{-1}}(\omega) = \pi h_{-1}/\omega \quad (\text{flicker frequency noise}) \tag{15}$$

$$S_{iy_{-2}}(\omega) = 2\pi^2 h_{-2}/\omega^2 \quad (\text{random walk frequency noise}) \tag{16}$$

and correspondingly, and respectively

$$S_{ix_0}(\omega) = h_0/2\omega^2 \tag{17}$$

$$S_{ix_{-1}}(\omega) = \pi h_{-1}/\omega^3 \tag{18}$$

$$S_{ix_{-2}}(\omega) = 2\pi^2 h_{-2}/\omega^4 \tag{19}$$

These can all be factored into the Fourier Transform of the impulse response $h(t)$, where respectively,

$$H_{y_0}(j\omega) = \sqrt{h_0/2} \tag{20}$$

$$H_{y_{-1}}(j\omega) = \sqrt{\pi h_{-1}}/\sqrt{j\omega} \tag{21}$$

$$H_{y_{-2}}(j\omega) = \sqrt{2\pi^2 h_{-2}}/j\omega \tag{22}$$

$$H_{x_0}(j\omega) = \sqrt{h_0/2}/\omega \tag{23}$$

$$H_{x_{-1}}(j\omega) = \sqrt{\pi h_{-1}}/(j\omega)^{3/2} \tag{24}$$

$$H_{x_{-2}}(j\omega) = \sqrt{2\pi^2 h_{-2}}/(j\omega)^2 \tag{25}$$

Converting these to La Place Transforms ($s=j\omega$) and using tables from Reference 5, we have the respective impulse responses

$$h_{y_0}(t) = \sqrt{h_0/2} \delta(t) \quad (26)$$

$$h_{y_{-1}}(t) = \sqrt{h_{-1}/t} ; t > 0 \quad (27)$$

$$h_{y_{-2}}(t) = \pi \sqrt{2h_{-2}} l(t) ; t \geq 0 \quad (28)$$

$$h_{x_0}(t) = \sqrt{h_0/2} l(t) ; t \geq 0 \quad (29)$$

$$h_{x_{-1}}(t) = 2\sqrt{h_{-1}t} ; t \geq 0 \quad (30)$$

$$h_{x_{-2}}(t) = \pi \sqrt{2h_{-2}t} ; t \geq 0 \quad (31)$$

Where $\delta(t)$ is the Dirac delta function and $l(t)$ is the unit response function.

We can now derive the autocorrelation, variance and cross-correlation functions of these processes from the following:

The autocorrelation function is

$$R(t, \tau) = \int_0^t \int_0^{t+\tau} h(t-u)h(t+\tau-v) E[n(u)n(v)] dv du \quad (32)$$

$$= \int_0^t h(u)h(u+\tau) du ; \tau \geq 0 \quad (33)$$

Using the property that

$$E[n(u)n(v)] = \delta(u-v) \quad (34)$$

and that

$$\int_0^{t+\tau} f(v)\delta(u-v)dv = f(u) \quad (35)$$

provided that $0 \leq u \leq t + \tau$, which it is if we restrict τ to be greater than zero. The variance of a process is then

$$\begin{aligned} \sigma^2(t) &= R(t,0) \\ &= \int_0^t h^2(u) du \end{aligned} \quad (36)$$

Similarly, the cross-correlation function between two processes is

$$R_{xy}(t, \tau) = \int_0^t h_x(u) h_y(u + \tau) du ; \tau \geq 0 \quad (37)$$

provided that they are driven by the same white noise process. (Otherwise $R_{xy}(t, \tau)$ is zero.)

For each process then

$$R_{y_0}(t, \tau) = \frac{h_0}{2} \delta(\tau) \quad (38)$$

$R_{y_{-1}}(t, \tau)$ is undefined

$$R_{y_{-2}}(t, \tau) = 2\pi^2 h_{-2} t ; \tau \geq 0 \quad (39)$$

$$R_{x_0}(t, \tau) = \frac{h_0}{2} t ; \tau \geq 0 \quad (40)$$

$$R_{x_{-1}}(t, \tau) = h_{-1} \left\{ (2t + \tau) \sqrt{t^2 + t\tau} - \frac{\tau^2}{2} \ln \left[\frac{2t + \tau + 2\sqrt{t^2 + t\tau}}{\tau} \right] \right\} \quad (41)$$

$$R_{x_{-2}}(t, \tau) = 2\pi^2 h_{-2} \left(\frac{1}{3} t^3 + \frac{1}{2} t^2 \tau \right) \quad (42)$$

$R_{y_{-1}}(t, \tau)$ does not exist because its impulse response (equation 27) is infinite at $t=0$. However, if one bounds the flicker noise spectral density to a frequency region of $f_l \leq f \leq f_h$, such as suggested in Reference 2, a stationary process is defined and an autocorrelation function can be defined as the inverse Fourier Transfer of the spectral density as

$$\begin{aligned}
 R_{y_{-1}}(\tau) &= h_{-1} \int_{2\pi f_1}^{2\pi f_h} \frac{\cos \omega \tau}{\omega} d\omega \\
 &= h_{-1} \ln \frac{f_h}{f_1} + h_{-1} \sum_{n=1}^{\infty} (-1)^n \frac{(2\pi f_h \tau)^{2n} - (2\pi f_1 \tau)^{2n}}{2n(2n)!}
 \end{aligned} \tag{43}$$

which is a well defined function of τ .

Then, the variances can be derived as

$$\sigma_{y_0}^2 = h_0 f h_0 \tag{44}$$

$$\sigma_{y_{-1}}^2 = h_{-1} \ln \frac{f_h}{f_1} \tag{45}$$

$$\sigma_{y_{-2}}^2(t) = 2\pi^2 h_{-2} t \tag{46}$$

$$\sigma_{x_0}^2(t) = \frac{h_0}{2} t \tag{47}$$

$$\sigma_{x_{-1}}^2(t) = 2h_{-1} t^2 \tag{48}$$

$$\sigma_{x_{-2}}^2(t) = \frac{2}{3} \pi^2 h_{-2} t^3 \tag{49}$$

Here, $\sigma_{y_0}^2$ is defined for a limited bandwidth f_h and $\sigma_{x_{-1}}^2$ is derived from equation 36. Cross correlations between frequency and time of like processes are then

$$R_{xy_0}(t, \tau) = \frac{h_0}{2}; \tau = 0 \tag{50}$$

$$= 0; \tau > 0$$

$$R_{xy_{-1}}(t, \tau) = 2h_{-1} \sqrt{t^2 + t\tau} - h_{-1} \tau \ln \left[\frac{2\sqrt{t^2 + t\tau} + 2t + \tau}{\tau} \right] \tag{51}$$

$$R_{xy_{-2}}(t, \tau) = \pi^2 h_{-2} (t^2 + 2t\tau) \tag{52}$$

or, for zero correlation time (cross-covariances).

$$R_{xy_0} = \frac{h_0}{2} \quad \text{ORIGINAL PAGE IS OF POOR QUALITY} \quad 53)$$

$$R_{xy_{-1}} = 2h_{-1}t \quad 54)$$

$$R_{xy_{-2}} = \pi^2 h_{-2} t^2 \quad 55)$$

Equations 44 through 49 and 53 through 55 could be used to define a covariance matrix at any time t describing the combined uncertainty in instantaneous time and fractional frequency. That is

$$\text{COV}[x(t), y(t)] = \begin{bmatrix} \frac{h_0}{2}t + 2h_{-1}t^2 + \frac{2}{3}\pi^2 h_{-2}t^3 & \frac{h_0}{2} + 2h_{-1}t + \pi^2 h_{-2}t^2 \\ \frac{h_0}{2} + 2h_{-1}t + \pi^2 h_{-2}t^2 & h_0 f_{h_0} + h_{-1} \ln \frac{f_h}{f_1} + 2\pi^2 h_{-2}t \end{bmatrix} \quad 56)$$

However, discrete Kalman filters do not estimate instantaneous frequency, but an average fractional frequency over a Kalman filter time interval Δt . Let that average fractional frequency be

$$\bar{y}(t) = \frac{x(t+\Delta t) - x(t)}{\Delta t} \quad 57)$$

Then, using equations 40 through 42 with $\tau = \Delta t$, but first simplifying equation 41 to a steady state value (large t/τ) of

$$R_{x_{-1}}(t, \tau) \approx 2h_{-1}(t^2 + t\tau) \quad 58)$$

and equations 47 through 49, a new covariance can be computed, where

$$\text{COV}[x(t), \bar{y}(t)] = \begin{bmatrix} \frac{h_0}{2}t + 2h_{-1}t^2 + \frac{2}{3}\pi^2 h_{-2}t^3 & 2h_{-1}t + \pi^2 h_{-2}t^2 \\ 2h_{-1}t + \pi^2 h_{-2}t^2 & \frac{h_0}{2\Delta t} + 2h_{-1} + \frac{2}{3}\pi^2 h_{-2}\Delta t + 2\pi^2 h_{-2}t \end{bmatrix} \quad 59)$$

all of which is a well-balanced function of t , except the 2,2 term that has terms as a function of Δt that basically describe the Allan standard deviation (within $\ln 2$).

Transformation to a 2-state Kalman Filter Covariance Model

It should be noted that both x and \bar{y} are nonstationary random processes that grow with time. If we wish to obtain a measure of this growth over a Δt interval, we simply let $t = \Delta t$ in equation 5) and obtain

$$\text{Cov}[x(\Delta t), \bar{y}(\Delta t)] = \begin{bmatrix} \frac{h_0}{2}\Delta t + 2h_{-1}\Delta t^2 + \frac{2}{3}\pi^2 h_{-2}\Delta t^3 & 2h_{-1}\Delta t + \pi^2 h_{-2}\Delta t^2 \\ 2h_{-1}\Delta t + \pi^2 h_{-2}\Delta t^2 & \frac{h_0}{2\Delta t} + 2h_{-1} + \frac{8}{3}\pi^2 h_{-2}\Delta t \end{bmatrix} \quad (60)$$

We now propose the following 2-state Kalman filter model. Let the state variables be defined as

$$\begin{aligned} x_1 &= x \text{ (i.e., time as before)} \\ x_2 &= \text{"Noisy" average frequency} \end{aligned} \quad (61)$$

The precise meaning of x_2 will be made apparent presently. Now, following the usual notation of Kalman filter theory [4], we let the transition matrix for a Δt interval be

$$\Phi = \begin{bmatrix} 1 & \Delta t \\ 0 & 1 \end{bmatrix} \quad (62)$$

and we let the Q matrix be

$$Q = \text{Cov}[x(\Delta t), \bar{y}(\Delta t)] \quad (63)$$

as given by equation 60.

We also postulate that we will step the estimate of the state vector and its error covariance ahead via the usual projection equations.

$$\hat{x}^-(t+\Delta t) = \phi \hat{x}(t) \quad 64)$$

$$P^-(t+\Delta t) = \phi P(t) \phi^T + Q \quad 65)$$

We will now have a proper Kalman filter model except for the measurement equation. This portion of the model depends on the situation at hand, so we will omit further discussion of this here. (For example, the clock model might be imbedded in a larger state model as in the GPS application [6].)

We now need to explore more carefully the connection between our postulated state model and the x and \bar{y} statistics as dictated by equation 60. First, by choosing our Q matrix as exactly that of equation 60, we are assured of having the proper growth of uncertainty in our time and average frequency estimates in the Δt interval. This is necessary in order to generate appropriate filter gains with each step of the estimation process. However, we cannot have x_2 in our state model represent true average frequency, and at the same moment require the 1,1 term of the Q matrix to be nonzero. This is not compatible with the defining equation for average frequency. That is, equation 57 states

$$x(t+\Delta t) = x(t) + \Delta t \cdot \bar{y} \quad 66)$$

Whereas, our state model says

$$x_1(t+\Delta t) = x_1(t) + \Delta t \cdot x(t) + w_k \quad 67)$$

We have defined x_1 to be x , and thus x_2 must differ from \bar{y} by the additive discrete white noise term $w_k/\Delta t$. We are comforted, though, with the fact that the average x_2 in the state model is equal to the usual average frequency.

It should be noted that the Kalman filter model proposed here is entirely self-consistent in terms of state-space theory. The transition matrix is legitimate in that it reduces to the identity matrix for $\Delta t=0$; and Q is positive-definite for all Δt as it must be to be a legitimate covariance

matrix. The only inconsistency lies in the state model's connection to the x, \bar{y} processes are described by equation 59. In view of the remarks about flicker noise in the companion paper in these Proceedings [4], we should not expect to be able to make this connection exact. No finite-order state model will fit flicker noise perfectly! Thus, something has to give. We intentionally kept the identity of time exact in our model, i.e., $x_1=x$. We then circumvented inconsistency in the state model by letting x_2 be a noisy version of \bar{y} . The filter's estimate of x_2 is still a valid estimate of frequency, though, because the mean of x_2 is \bar{y} .

An Example

Standard deviation plots of the time state $x(t)$ of typical crystal oscillators are plotted in Figures 2 and 3, whose Allan variance characteristics are represented in Figure 4. Also shown in Figure 4 are plots of the standard deviation of time $\sqrt{Q_{11}(\tau)}$ divided by τ for comparison to the two-sample standard deviation. It has been suggested in the past that a procedure to estimate the standard deviation of time is to simply multiply the two-sample standard deviation by the elapsed time. These plots either verify that estimate or verify the validity of the derivation provided earlier.

Kalman Filter Measurement Noise

Suppose one uses a phase lock loop to track the phase difference between an oscillator and a reference frequency source as shown in Figure 5. The variance of the tracking error $\delta\phi$ in radians due to phase noise of the oscillator is given as

$$\sigma_{\delta\phi}^2 = \int_0^{f_h} S_{\phi}(f) \cdot |1 - H_{PLL}(j2\pi f)|^2 df \quad (68)$$

where

$$|1 - H_{PLL}(j2\pi f)|^2 = \frac{f^4}{f^4 + f_N^4} \quad (69)$$

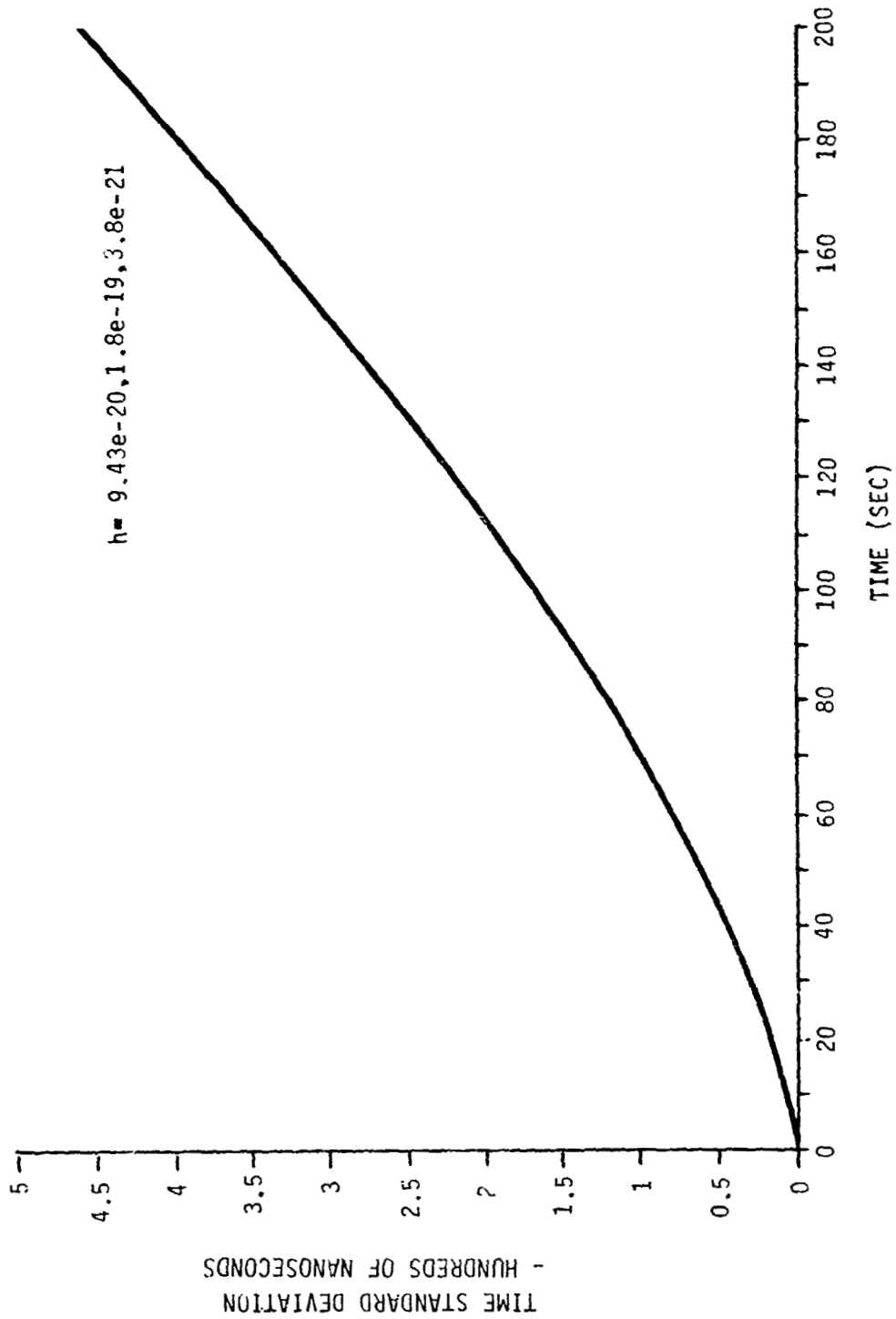

FIGURE 2 STANDARD DEVIATION OF TIME FOR A 5 PARTS IN 10^{10} CRYSTAL OSCILLATOR

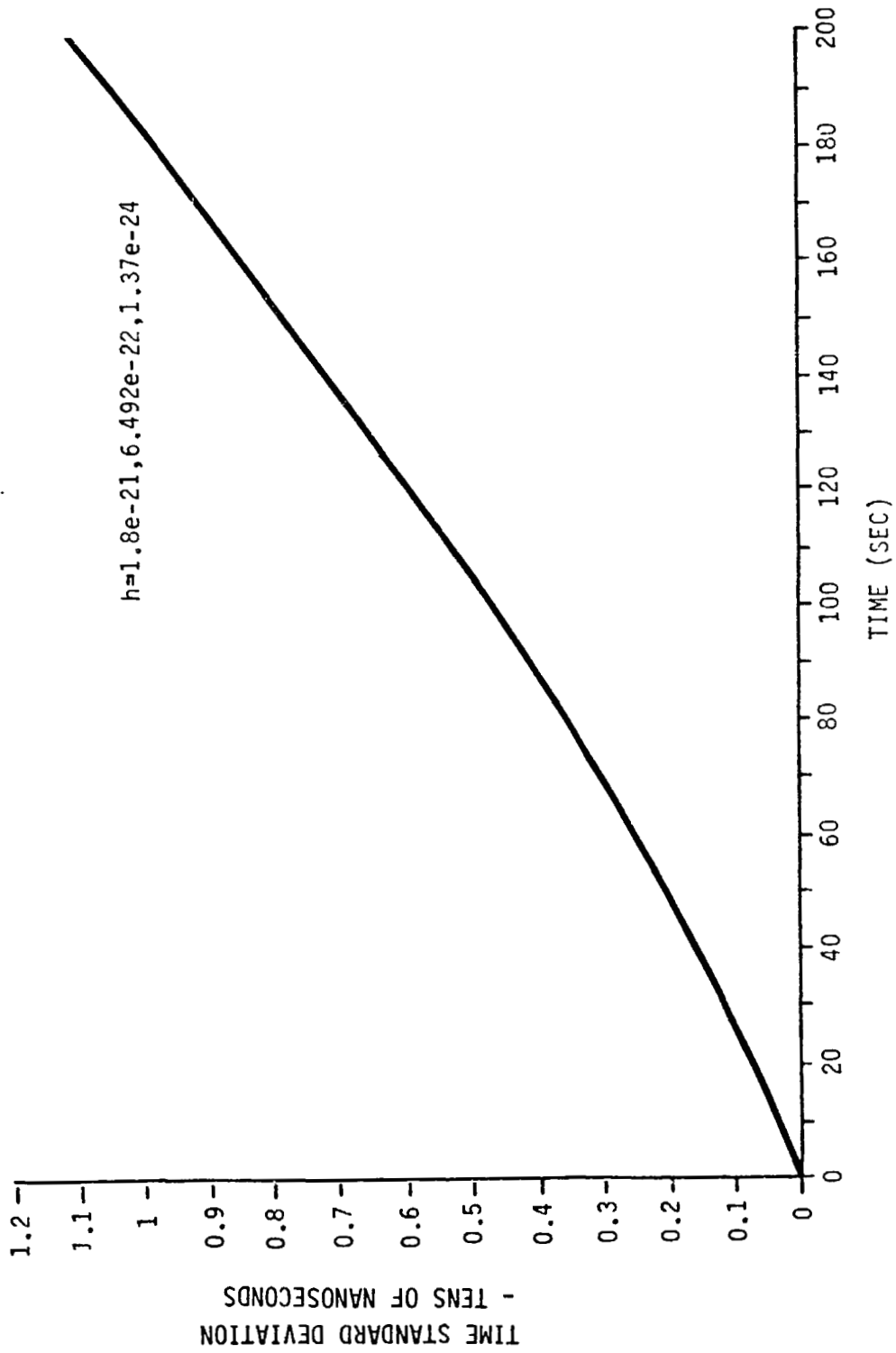

FIGURE 3 STANDARD DEVIATION OF TIME FOR A 3 PARTS IN 10^{11} CRYSTAL OSCILLATOR

ORIGINAL PAGE IS
OF POOR QUALITY

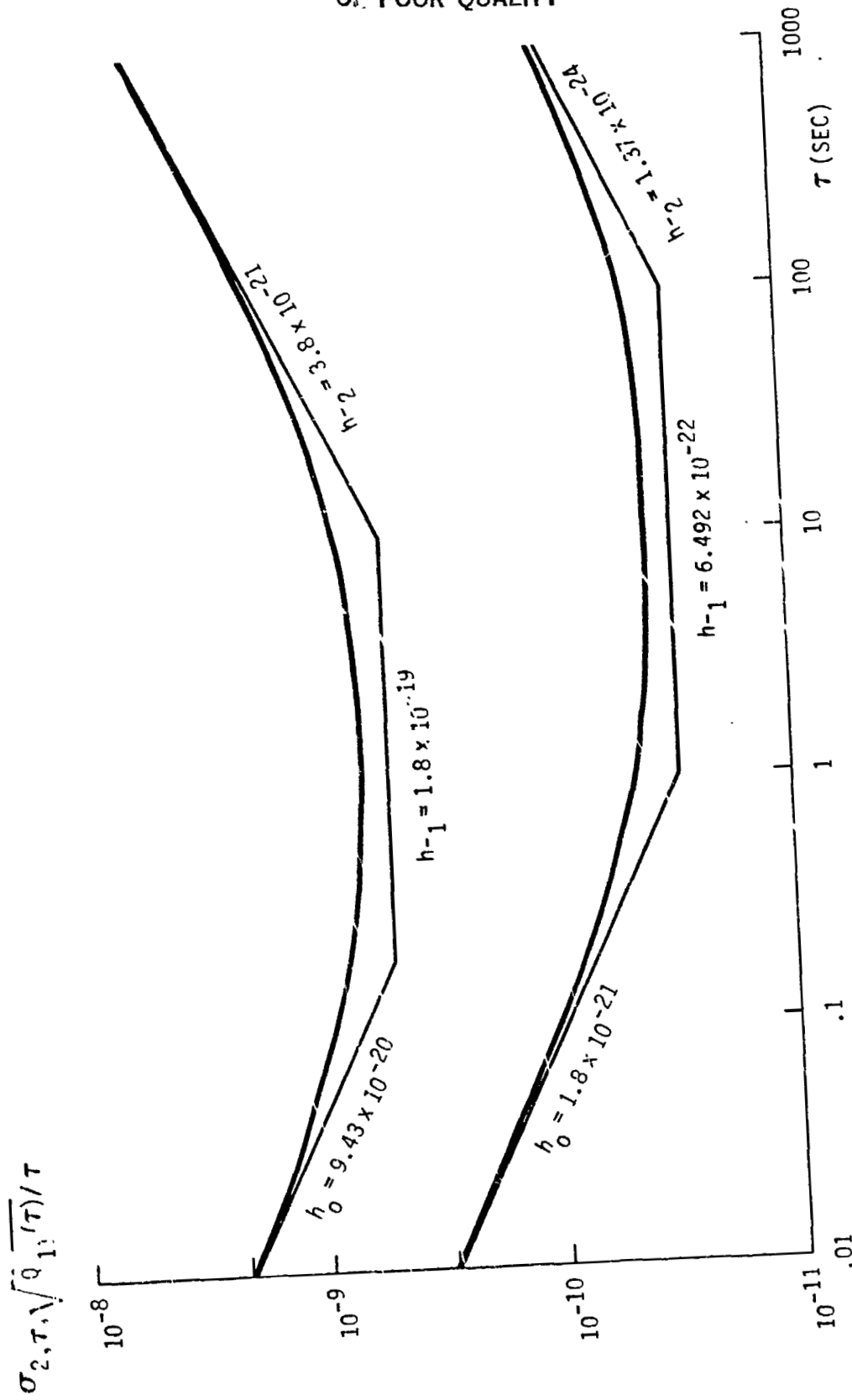

FIGURE 4 $\sigma_{2,\tau}$ AND $\sqrt{Q_{11}(\tau)} / \tau$ FOR TWO TYPICAL CRYSTAL OSCILLATORS

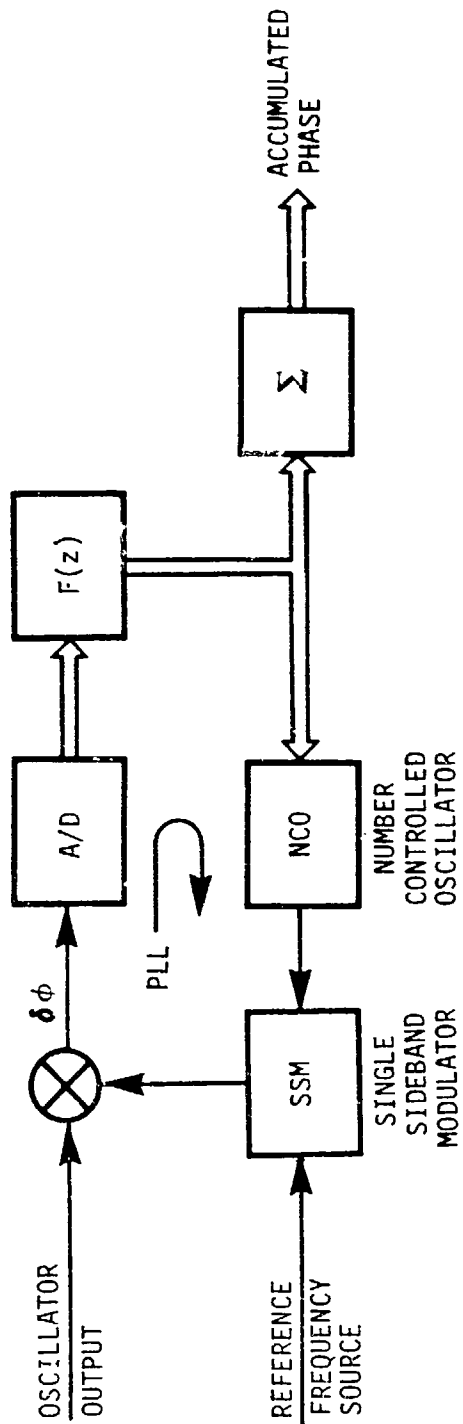

FIGURE 5 PHASE LOOP MEASURING OSCILLATOR PHASE

of a phase lock loop with corner frequency f_N and damping ratio of $\sqrt{2}/2$, and $S_\phi(f)$ is the phase noise spectral density represented in equation 9. $\sigma_{\delta\phi}^2$ represents that part of the measurement error introduced into the Kalman Filter. It is usually affected mostly by the h_2 , h_1 and h_0 terms of $S_\phi(f)$, depending upon the loop bandwidth.

In a laboratory environment, the measurement error whose variance is depicted in equation 69 may be the only measurement error of significance. However, in such systems as GPS, it is usually dominated by thermal noise and other system effects.

SUMMARY AND CONCLUSIONS

Because of flicker noise, good models of clocks for Kalman Filters can be elusive. In this paper we derived a two state model of clock characteristics that can be used in a Kalman Filter. It represents the characteristics of a clock described in terms of Allan variance parameters. We believe the models presented within this paper are a vast improvement over those used in most applications of the NAVSTAR GPS system, and that they could also be used in many other applications of time and frequency where real-time estimates and predictions of time and frequency are required.

ACKNOWLEDGMENT

The authors are indebted to Dr. James A. Barnes for his suggestion that the second state variable in our model should not be referred to as average frequency, which already has precise meaning in the PTI community.

REFERENCES

- [1] Barnes, J.A. and Allan, D.W., "A Statistical Model of Flicker Noise," Proceedings of the IEEE, Vol. 54, No. 2, February, 1966.
- [2] Barnes, James A., "Models for the Interpretation of Frequency Stability Measurements," NBS Technical Note 683, August 1976.
- [3] Time and Frequency: Theory and Fundamentals, Byron E. Blair, Editor, NBS Monograph 140, May 1974.
- [4] Brown, R. Grover, "Kalman Filter Modeling," paper presented at this conference.
- [5] Brown, R.G., and Nilsson, J.W. Introduction to Linear Systems Analysis, John Wiley, 1962.
- [6] Van Dierendonck, A.J. and Hua, Q.D., "Enhancements to the TTS-502 Time Transfer System," Proceedings of the Fifteenth Annual Precise Time and Time Interval (PTTI) Applications and Planning Meeting, December, 1983.

QUESTIONS AND ANSWERS

VICTOR REINHARDT, HUGHES AIRCRAFT CO.: I have a comment on f sub h and f sub l . They are not really arbitrary, but real physical parameters that have to be set by the experiment. Just as with the white noise process, you have to set the bandwidth before you can define the amount of noise that's going to enter the system. The white noise process is another process that requires the definition of the high frequency limit, and flicker noise, a low frequency limit. I think that's real effect, because the Allan variance goes to infinity. So, those are real things that you have to define, they are not arbitrary. I do think that you can leave those parameters as things to be defined by the person using the model.

MR. BROWN: There was something that you said that I didn't understand. What is it that goes to infinity? The second difference is stationary, that is the reason that it is used.

MR. REINHARDT: I am talking about the effect of having a dead time in the Allan variance, when the dead time between samples goes to infinity. The variance does go to infinity then. Or, if you have N samples, the process goes to infinity as $\log N$.

What this means is that there is definitely a low frequency cut-off parameter which has to be considered in your measurement process, which may not necessarily be associated with τ .

MR. ALLAN: I think that one can make a general statement about this whole argument. The Kalman filter concept is strongly model dependent, and no model is perfect. The fact that, in the case of flicker noise, we may need to approximate the state matrix with a few terms doesn't bother me at all, because the model is approximate anyway.

Whether you are talking about white noise or other noise, it's approximate at every leg of the trip, and you have to approximate for flicker noise or anything else. You have a finite measuring system bandwidth in the real world. You have low frequency and a high frequency cut-off, so these are only approximations to the ideal. I think that everything fits together rather well.

MR. BROWN: I certainly agree with that. In this particular model that Al and I have come up with, we were working especially hard to come up with a two state model, and there have to be serious approximations in that.

I do plan to have a student working on this through the winter doing some simulations to see which of the two state models, or which of these options will work out to be the best. Of course, we are not absolutely limited to a two state model. We thought that it would be nice, with all the other approximations that go into the thing, to just keep it a two state model.