

## General Disclaimer

### One or more of the Following Statements may affect this Document

- This document has been reproduced from the best copy furnished by the organizational source. It is being released in the interest of making available as much information as possible.
- This document may contain data, which exceeds the sheet parameters. It was furnished in this condition by the organizational source and is the best copy available.
- This document may contain tone-on-tone or color graphs, charts and/or pictures, which have been reproduced in black and white.
- This document is paginated as submitted by the original source.
- Portions of this document are not fully legible due to the historical nature of some of the material. However, it is the best reproduction available from the original submission.

DRA/JOHNSON

# MISSION SCIENCE REQUIREMENTS DOCUMENT

## FIRST LIFE SCIENCES DEDICATED MISSION



### PART I

### SPACELAB LIFE SCIENCES 1

JUNE 1, 1982



(NASA-TM-87494) LIFE SCIENCES FLIGHT  
 EXPERIMENTS PROGRAM MISSION SCIENCE  
 REQUIREMENTS DOCUMENT. THE FIRST LIFE  
 SCIENCES DEDICATED SPACELAB MISSION, PART 1  
 (NASA) 92 p HC A05/MP A01 CSCL 22A G3/16

Ng5-32137

Unclassified  
25053

LIFE SCIENCES FLIGHT EXPERIMENTS PROGRAM

Mission Science Requirements Document

The First Life Sciences Dedicated  
Spacelab Mission

PART I

Prepared by:

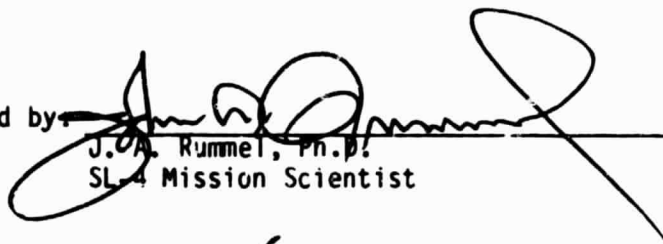

J. A. Rummel, Ph.D.  
SL-4 Mission Scientist

Approved by:



W. J. Huffstetler  
Manager, Spacelab Mission Management Office

Approved by:



W. E. Rice  
Director of Space and Life Sciences

Approved by:

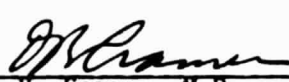

D. B. Cramer, M.D.  
Acting Chief, Flight Programs Branch

Approved by:

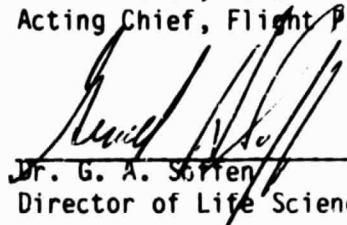

Dr. G. A. Scrien  
Director of Life Sciences Division

## FOREWORD

The Mission Science Requirements Document (MSRD) for the First Dedicated Life Sciences Mission (LS-1) represents the culmination of thousands of hours of NASA personnel, NASA support contractors, and principal investigators participation in proposal preparation, experiment selection, and science requirement definition activities. NASA life sciences has never before attempted to integrate, both scientifically and operationally, a single mission dedicated to life sciences research, and the complexity of the planning required for such an endeavor should be apparent. This set of requirements completes the first phase of a continual process which will attempt to optimize (within available programmatic and mission resources) the science accomplished on this mission.

No one should assume that the contents of this document are static and that there will not be changes in science requirements. For one to do so, one would have to ignore the scientific process, which, for this mission, started with proposal preparation in 1978.

John A. Rummel, Ph.D.  
SL-4 Mission Scientist

PRECEDING PAGE BLANK NOT FILMED

TABLE OF CONTENTS

Part I

	Page
Foreword	iii
1.0 <u>MISSION SCIENCE OVERVIEW.</u> . . . . .	1-1
1.1 PURPOSE AND SCOPE OF MISSION SCIENCE REQUIREMENTS DOCUMENT . . . . .	1-1
1.2 INTRODUCTION . . . . .	1-1
1.3 SPACE LIFE SCIENCES RESEARCH . . . . .	1-8
1.4 THE SCIENCE PAYLOAD, A SUMMARY . . . . .	1-15
1.4.1 <u>Cardiovascular/Cardiopulmonary Discipline.</u> . .	1-15
1.4.2 <u>Vestibular Discipline.</u> . . . . .	1-23
1.4.3 <u>Renal/Endocrine Discipline</u> . . . . .	1-27
1.4.4 <u>Hematology Discipline</u> . . . . .	1-32
1.4.5 <u>Immunology Discipline</u> . . . . .	1-38
1.4.6 <u>Muscle Discipline</u> . . . . .	1-39
1.4.7 <u>Calcium Metabolism/Bone Discipline</u> . . . . .	1-45
1.4.8 <u>Gravitational Biology Discipline</u> . . . . .	1-49
1.5 PAYLOAD CHARACTERISTICS AND MISSION OBJECTIVES . . . .	1-54
1.5.1 <u>Payload Synthesis.</u> . . . . .	1-54
1.5.2 <u>Mission Objectives</u> . . . . .	1-72
1.6 BIBLIOGRAPHY . . . . .	1-72
APPENDIX A. INVESTIGATORS FOR PROPOSED DEDICATED SPACELAB PAYLOAD . . . . .	A-1

Part II

2.0 <u>SCIENCE REQUIREMENTS: DEFINITION OF TERMS</u> . . . . .	2-1
3.0 <u>THE MISSION SESSIONS</u> . . . . .	3-1

PAGE iv INTENTIONALLY BLANK

v

PRECEDING PAGE BLANK NOT FILMED

TABLE OF CONTENTS (CONTINUED)

	Page
4.0 <u>INTEGRATED SCIENCE VERIFICATION REQUIREMENTS . . . . .</u>	4-1
5.0 <u>DISCIPLINE SCIENCE REQUIREMENTS: HUMAN EXPERIMENTS . . . .</u>	5-1
6.0 <u>DISCIPLINE SCIENCE REQUIREMENTS: NON-HUMAN EXPERIMENTS . .</u>	6-1

Part III

5.3 PROJECT SESSION SAMPLE SUMMARIES: HUMAN EXPERIMENTS

6.3 PROJECT SESSION SAMPLE SUMMARIES: NON-HUMAN EXPERIMENTS

## 1.0 MISSION SCIENCE OVERVIEW

### 1.1 PURPOSE AND SCOPE OF MISSION SCIENCE REQUIREMENTS DOCUMENT

This document, the Mission Science Requirements Document for the first life sciences dedicated Spacelab mission (SL-4), contains a detailed presentation of the scientific aspects of the various investigations presently under consideration for flight on the SL-4 opportunity. All experiments discussed in this document were originally submitted in response to Announcement of Opportunity OSS-1-78 and represent 25 tentatively selected experiments out of a total of 363 proposals originally submitted.

The purpose of this document is to present the scientific requirements of the 25 investigations in a form that is suitable for implementing the experiments and placing them into near-Earth orbit on the SL-4 flight. Because the resources of Spacelab are all finite and, hence, limited, it is obvious that certain resources may play key roles in the determination of what can, or should, be done on a Spacelab mission. Feasibility studies have shown that the amount of available crew time is probably the single most important of the available resources for this mission and that available crew time will limit the experimentation more severely than any other single resource. With this in mind, crew-time estimates are included in the appropriate portions of this document, and investigations, or portions of investigations, have been grouped according to their relative importance to the achievement of the objectives of this mission. In this way, mission strength and flexibility can be maintained for future, comprehensive contingency planning.

Section 1.0 of this document presents an overview of the main scientific characteristics of the recommended payload, including a discussion of the major objectives of the SL-4 mission. Terms used in this document are defined in section 2.0, while section 3.0 presents a detailed description of the actual scientific components of this mission, the mission sessions. In section 4.0, the need for integrated science verification is discussed. Sections 5.0 and 6.0 contain the discipline science requirements for the human and non-human portions of the payload. Appendix A contains a list of the investigators involved in this mission. Section 1.0 and appendix A are included in Part I of this document. Sections 2.0 through 6.0 with the exception of sections 5.3 and 6.3 are contained in Part II. These latter sections comprise Part III of this document.

### 1.2 INTRODUCTION

The recent flights of the Space Shuttle have ushered in a new era for exploring the microgravic environment of space, and, if present promise is borne out, the future will see a significant increase in the number of near-Earth manned space flights. Such space operations will be less complex, and less costly than similar operations with expendable launch vehicles. By the late 1980's, Shuttle launches should be a routine event with frequent flights and a large number of astronauts venturing into space. During this new era, the portable laboratory, Spacelab, will provide an opportunity for research of various kinds to be conducted under conditions approximating those obtained in ground-based laboratories. In effect, the ground rules for research in the nearly weightless environment of space are rapidly changing.

Opportunities for the life sciences community to participate directly in the Shuttle flight program should increase in the future as well. The Spacelab will provide the capabilities to fly large numbers of life sciences experiments, to retrieve and reuse experimental equipment, and to undertake multiple-flight studies. Life scientists will be able to exploit the unique nature of the space environment by studying the effects of space on a variety of biological specimens, including man.

The NASA Life Sciences Flight Experiments Program (LSFEP) is designed to take full advantage of the research opportunities afforded by the Shuttle flight program. The LSFEP currently has two broad scientific objectives. The first concerns scientific investigations which promote the safety, well being, and productivity of man in space. The second goal involves the utilization of the environment of space to further man's understanding of fundamental problems in gravitational biology. The LSFEP provides the programmatic capabilities to solicit, select, develop, and implement flight experiments in the life sciences.

Data already collected during space flight demonstrate that man undergoes various physiological changes in zero gravity. While these changes have previously proven reversible on return to Earth, many of them are physiologically significant and not entirely understood. Weightless exposure beyond a few months may cause these changes to either stabilize or to acquire medical significance. Missions of several months duration will be required to resolve this question; however, the early, short-duration Spacelab missions are suitable for gaining a greater understanding of the immediate physiological responses to weightlessness. A thorough understanding of these responses will improve the management of several existing problems such as space sickness, and should enhance the confidence level for determining the physiological consequences of more sustained weightless exposure.

In addition to investigations related to the concern for man's safety and well being, there exists a family of basic problems in gravitational biology that is most suitable for study in early Spacelab missions. These problems involve observations of biological systems that are thought to be acutely dependent on gravity for proper function, and initial studies will focus on the early growth and development of several species, including plants.

The dedicated life sciences mission, with which this document is concerned, will provide the first opportunity to study the acute effects of weightless exposure in a comprehensive, interrelated fashion using both man and animals. For this mission, the primary emphasis will be on gathering more complete and extensive data related to previously observed physiological changes in humans (through both human and animal studies), although the mission will contain investigations dealing with a broad variety of areas related to weightlessness. The study of space-flight effects on man and animals requires a careful integration of systematic measurements across the involved organ systems for as long as possible, and hopefully, for as long as the effects persist. This is because an induced change in any one organ system generally produces complex, time-dependent ripple effects on other systems, making causal relationships difficult to discern. The necessary approach encompasses such experimental design complexity as to fully utilize the Spacelab, thus requiring a dedicated mission.



The dedicated mission holds many potential benefits. The synergistic effect of a well integrated payload results in a scientific yield that far exceeds that of its component experiments conducted independently. This arises through combining separate investigations in such a way as to eliminate any redundant measurements, to optimize complementary approaches to a problem, and to maximize the sharing of individual measurements. Certain measurements of biological investigations such as vital signs, simple chemistries of blood and urine, and routine blood counts are of considerable interest to any investigator employing that experimental subject. Complementary approaches commonly extend across organ systems in the same subject but may also extend across species. In the latter case, the objective is often to validate an animal model as a human surrogate. The dedicated mission also guarantees that the Payload Specialists will be trained Life Scientists which permits far more sophisticated data gathering in space.

The concept of a life sciences dedicated mission evolved from a desire to fully utilize the unique life science opportunities afforded by the Space Shuttle/Spacelab system. The process of actually developing a payload for a dedicated life sciences Spacelab mission was initiated when an Announcement of Opportunity was published by NASA in February of 1978. (Figure 1.1 depicts the major events in the life of the SL-4 payload.) The Announcement of Opportunity requested proposals for flight experiments and provided information on the particular flight opportunities available. The 363 proposals which were received were subjected to an evaluation and selection process. The American Institute of Biological Sciences (AIBS) convened 13 peer review panels which provided summaries of strengths and weaknesses on the proposals to NASA Life Sciences in October 1978. NASA completed cost, engineering, integration, and management evaluations in March of 1979. This combined information was provided to the Life Sciences Steering Committee (LSSC), an ad hoc subcommittee of the Space Sciences Steering Committee (SSSC) consisting of NASA personnel. The LSSC categorized the proposals after considering their scientific merit, engineering feasibility, cost, and management factors. These recommended categorizations were passed on to the SSSC which conducted review of the selection process. The SSSC presented its recommendations for tentative selection to the Associate Administrator, Office of Space Sciences, who made the selection of proposals for definition phase activity in October 1979. Approximately 119 proposals were included in this group.

During the definition phase, the tentatively selected proposals were analyzed for all the various resources required for implementation, and their scientific objectives were clarified when necessary. Requirements which were assessed included data, hardware, facilities, training, testing, integration, inflight operations, safety, and specimen handling. A detailed estimate of the experiment cost and a schedule for equipment development were also produced as a result of this phase. The definition phase activity culminated in the preparation of the Experiment Requirements Document (ERD) in which the specific experiment requirements and objectives were documented. As a result of this activity, detailed analyses of experiment requirements and objectives were able to be compared with program resources and guidelines. As Spacelab resources became better defined, this information was utilized to insure that experiment requirements did not exceed available resources. The feasibility of various candidate payloads was determined based on payload requirements, resources, and guidelines.

# SPACELAB 4 EXPERIMENTS PIPELINE

FIGURE 1.1

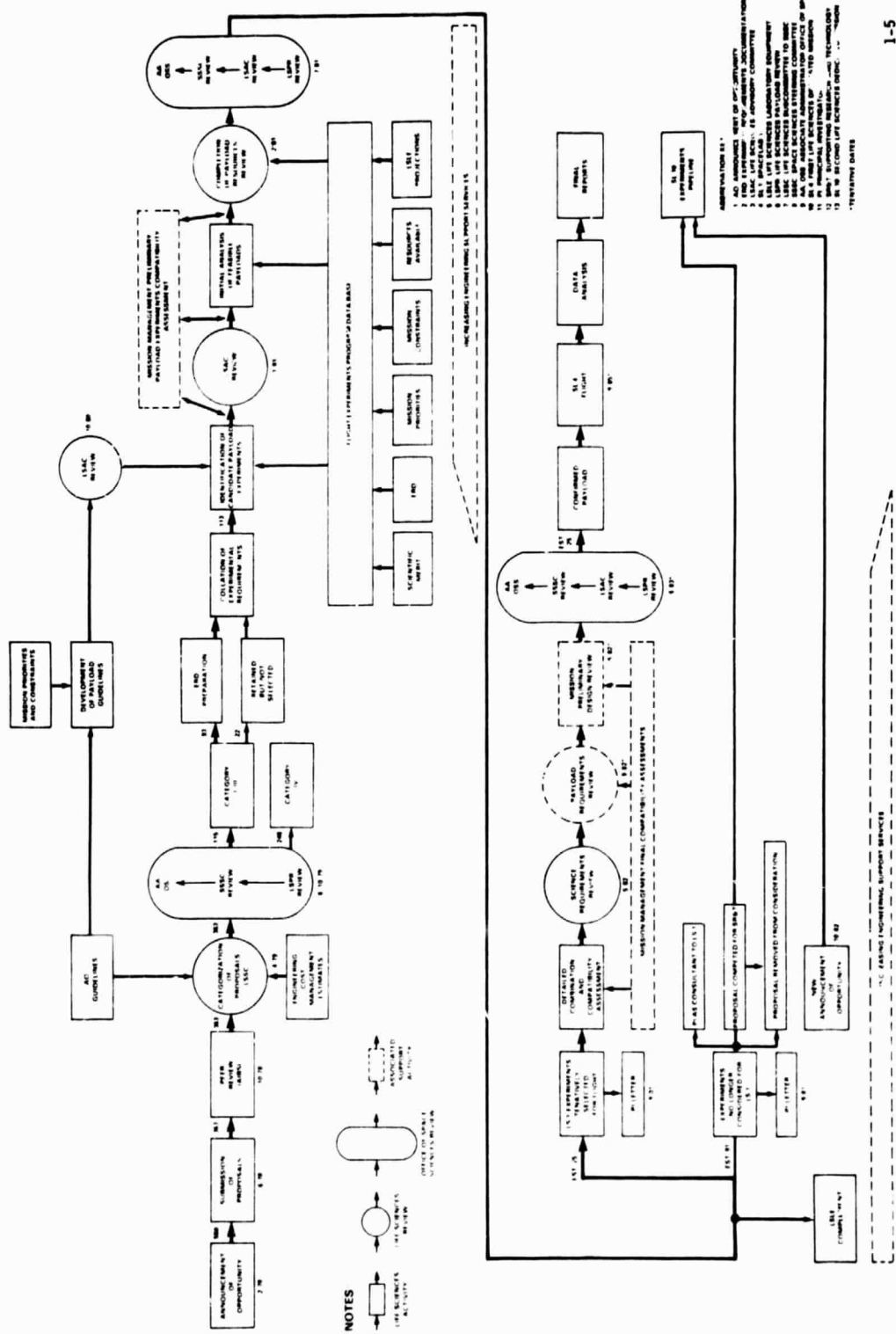

ORIGINAL PAGES  
OF POOR QUALITY

The following guidelines as established by the Director of Life Sciences were utilized in the payload optimization process:

- o The proposed experiment must possess high merit, require access to the space environment, and possess a reasonable likelihood of success within the constraints of Spacelab.
- o For SL-4, preference will be given to those experiments addressing significant, known problems of manned space flight and employing human or appropriate animal subjects.
- o Preference on the SL-4 mission will be given to those experiments which scientifically complement each other and, when so combined, represent a more efficient utilization of the available Spacelab resources.
- o Experiments for the SL-4 mission will also be selected to maintain a scientifically balanced payload which addresses fundamental biological problems.

These guidelines reflect an expression of programmatic goals of the LSFEP and are entirely consistent with the Announcement of Opportunity objectives.

The final candidate payload selection resulted from several iterative assessments of scientific priorities and expected scientific yield versus such payload constraints as budget, crew-time availability, engineering limitations, and safety factors. The collection of experiments that would proceed to the development stage was selected by the Associate Administrator, Office of Space Sciences, in June 1981 after reviews by the Life Sciences Program Office and the SSSC.

Following tentative experiment selection, considerable effort was expended to combine investigations with complementary scientific objectives, to eliminate any redundant measurements, to maximize sharing of measurements, and to develop and validate animal models of important human problems. The notion of synergism was important in payload synthesis in that experiments were viewed in relation to a well-integrated payload, thus maximizing the scientific return. The end goal, an optimal scientific payload within major resource guidelines, was the culmination of several reviews, including those of the Life Science Program Office and the SSSC.

The first dedicated life sciences mission, which will be flown on Spacelab-4 (SL-4), is scheduled for launch in late 1985. Twenty-five experiments have been tentatively selected to make up the scientific payload. The investigations are arranged into eight disciplines including cardiovascular/cardiopulmonary, vestibular, renal-endocrine, hematology, immunology, muscle, calcium metabolism/bone, and gravitational biology. Eleven investigations will utilize human subjects; nine will share 48 laboratory rats. Two studies will share four squirrel monkeys; two involve small plants, and one experiment involves frog eggs.

PRECEDING PAGE BLANK NOT FILMED

## 1.3 SPACE LIFE SCIENCES RESEARCH

### Historical Perspective

The history of life science research in space dates back to the very beginnings of space technology in the late 1940's with attempts to fly biological specimens, including primates, in balloons and rockets. The main purpose of these early attempts was to assess the possible adverse consequences of exposure to brief periods of weightlessness and upper atmospheric radiation, matters which were largely unknown at that time. The data accumulated from studies through the early 1950's firmly established the survivability of organisms in space.

A series of flight studies involving chiefly primates in the U.S. and dogs in the Soviet Union preceded the launching of man into Earth's orbit in 1961. These studies were intended to test the safety of the space environment, to assess the ability of primates to withstand the stresses of launch and reentry, and to evaluate the suitability of a cramped space capsule for subsequent use with man. Their major goal was to refute or substantiate the predictions of possible catastrophic failures in various vital functions of animals suddenly thrust into an environment with negligible gravitational force. The animals were instrumented to monitor a number of physiologic variables related to cardiovascular changes and metabolic balance. The observed increases in blood pressure, pulse frequency, and respiration rate were well within physiological tolerance limits, thus demonstrating that weightlessness could be experienced without markedly adverse physiologic effects, at least for a short duration flight of a few hours.

Manned flights into space began with the Mercury Program in the U.S. and the Vostok Program in the Soviet Union. Data from Mercury flights made apparent some of the acute manifestations of weightless exposure of less than 2 days duration. These manifestations included orthostatic intolerance upon return to one-g, hemoconcentration, and weight loss, a part of which was due to dehydration. A postflight degradation in cardiovascular performance was not reported in any Russian Cosmonaut until the Soyuz-3 flight in 1968, 7 years after the first Russian manned orbital flight.

The biomedical studies of the U.S. Gemini Program confirmed and extended the findings of the earlier Mercury flights. Some of the missions of the Gemini series included inflight measurements in addition to pre- and postflight tests. Particular emphasis was placed on the study of the cardiovascular system because of the known cardiovascular impairment due to weightless exposure in Mercury astronauts. Further physiologic effects of space flight were observed in Gemini astronauts. These include moderate losses of red cell mass and exercise capacity and minimal losses of bone density, bone calcium, and muscle nitrogen.

Eleven more manned missions were completed in the U.S. in a 5-year span during the Apollo Program that followed the Gemini series. Again, the biomedical studies were limited mostly to pre- and postflight testing. The presence of vestibular disturbances was reported for the first time in a U.S. space flight. This problem had been predicted in the 1960's as a probable effect of weightless flight and had long plagued the Soviets. As early as 1961, the Cosmonaut of Soviet flight Vostok-2 experienced vestibular

dysfunction leading to nausea. Other biomedical findings from the Apollo missions were related to cardiovascular deconditioning and fluid-electrolyte metabolism and generally confirmed the previous observations.

A year after the end of the highly successful Apollo series of flights, the U.S. space orbiting laboratory, Skylab, was launched in May 1973. The manned Skylab missions that followed provided a very unique opportunity to conduct the first comprehensive program of biomedical investigations in the history of space-flight experimentation. The physiological adaptation of human subjects exposed to prolonged periods of weightlessness were studied in three separate flights of 28, 59, and 84 days duration. Unlike the previous missions in which few inflight tests were performed, Skylab had equipment onboard for extensive physiologic testing and continuous monitoring. A partial list of equipment available included a rotating chair for assessment of vestibular changes, a bicycle ergometer for the study of cardiopulmonary and metabolic systems, a lower-body negative pressure (LENP) device for studying orthostatic intolerance, collection systems for blood, urine and feces, and devices for measurements of body mass and leg volume. A large amount of biomedical data were obtained from the studies conducted on the three missions involving nine astronauts. The studies conducted on Skylab not only confirmed the previous findings, but, more importantly, shed considerable light on the possible adaptive processes that are set in motion upon entry into the zero-g environment. The single most important conclusion from the biomedical results of Skylab is that man can adapt and function effectively in a weightless environment for extended periods of time.

The American Skylab series ended in February 1974, while the Soviet Soyuz missions continued through the 1970's. Many of the Soyuz missions included docking with the Soviet space laboratory, Salyut. Prior to the launching of Salyut-1 in June 1971, extensive biomedical investigations were made for the first time in a Soyuz-9 mission that lasted for 18 days. These investigations were continued and extended in many later Soyuz/Salyut flights of extended duration, lasting up to a record 185 days in space in the case of Soyuz-35/Salyut-6. The observed physiological effects of weightless exposure were in general agreement with the Skylab findings. While there was no impairment of health or performance in zero-g, notable physiologic changes were observed upon return to one-g.

Although the life sciences research of American and Soviet manned missions have been chiefly concerned with physiological effects of zero-g in humans, many missions included experiments on plants, bacteria, fungi and protozoa, tissue cultures, invertebrates, and non-human vertebrates. Such non-human experiments have been more extensively pursued on American Biosatellite and Soviet Cosmos flights. By and large, these experiments showed that weightlessness per se had very little effect on simple animal organisms, although some interesting changes in plant orientation were discovered. In recent years, U.S. participation in the Russian Cosmos series of flights has produced many interesting findings of significance regarding the physiology of weightlessness in rats.

Finally, this brief historical sketch would be incomplete without some mention of ground-based studies in human subjects using analogs of weightlessness, including supine bed rest, water immersion, and head-down tilt. The medical studies with bed rest antedate those that have been

conducted in zero-g and have been pursued more vigorously in both the U.S. and the Soviet Union since the emergence of space programs. Ground-based studies on animals have also been conducted using immobilization, head-down tilt, dehydration, and lower-body positive pressure to simulate conditions akin to zero-g. Such studies with such one-g analogs of weightlessness have been valuable in formulating hypotheses related to the physiology of weightlessness by providing measurements that are not feasible in a confined space environment.

### Current Status of Research in Space Physiology

Gravitational space biology is just beginning to emerge as a general science. One branch of that science is involved with human physiology and man's ability to adapt to, and work in, the weightlessness environment; this particular branch has a relatively long history for such a new field. Research in weightlessness has its special difficulties and challenges. Until now, opportunities for conducting research in space have been limited by infrequent flights and the high cost of gathering data. As a result, only a small number of subjects have been studied, and the statistical significance of the observed changes has been difficult to assess. In addition, for valid and understandable reasons, the types of measurements made on man have been limited.

The greatest emphasis of the research in space physiology has been in identifying and characterizing gross disturbances in a number of physiological systems. These individual systems are themselves complex, containing both competing and redundant pathways and multiple interconnections. The limitations of flight research have precluded the systematic study necessary to elucidate these underlying mechanisms. Interpretation of the space-flight findings has, therefore, been largely a speculative effort, aided to a significant extent by ground-based analogs of weightlessness and other more fundamental studies of basic terrestrial physiology, both in humans and animals. The most difficult problem remaining involves unraveling the integrated total human physiological response to obtain an understanding of the role that each of the major components of that system plays following the transition to and from space. The use of the Shuttle Spacelab facility and an active life sciences research program are essential to this effort.

One concept of our current understanding of the human physiological responses to weightlessness is illustrated in Figure 1.2. This attempt to formulate a unified view of the adaptive processes should be treated with appropriate caution, since some of the interconnections shown have not been confirmed by direct experimental evidence. Nevertheless, the following broad picture has emerged.

Disturbances in the cardiovascular, fluid-electrolyte, erythropoietic, musculoskeletal, and metabolic systems, which are found during and after space flight, appear to be attributed to at least two major effects of weightlessness. First, the absence of hydrostatic forces results in redistribution of the body fluids in a manner favoring upper body hypervolemia. Correction of this disturbance by fluid regulating systems leads to a reduction in extracellular fluids, most importantly, blood volume. Second, the absence of deformation forces results in degradation of normally load-bearing tissues with the major consequence being a reduction of

Figure 1.2

# INTEGRATED HYPOTHESIS OF PHYSIOLOGICAL ADAPTATION TO PROLONGED SPACE FLIGHT

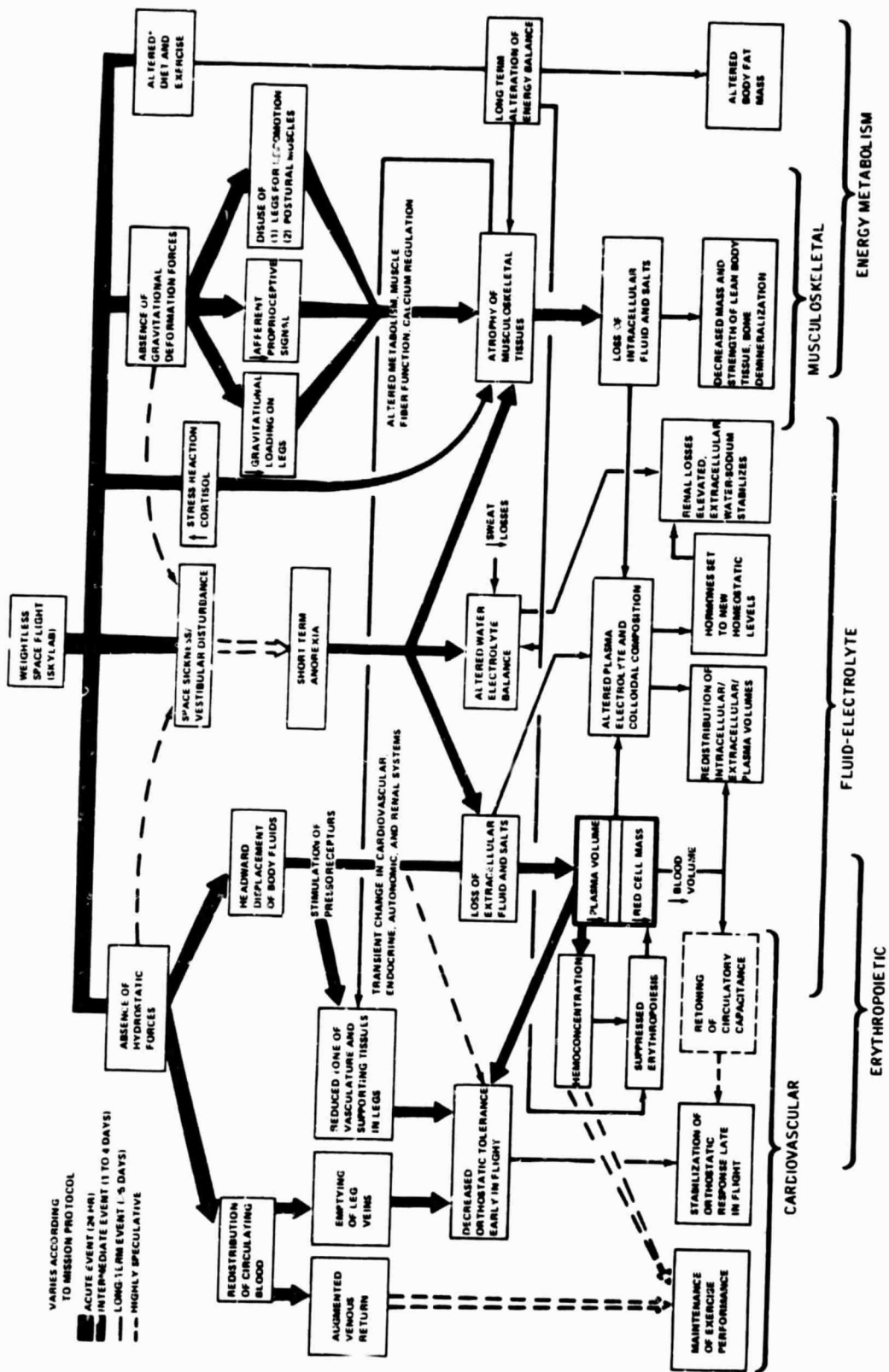

intracellular constituents of bone and muscle mass. In addition, a third factor, a long-term alteration of the metabolic state, reflected in part by changes in dietary intake and influenced by exercise levels and by weightlessness itself, in some undefined manner, was found to play an important role in the responses of the Skylab crews. For example, a diminished dietary intake (both voluntary and involuntary) appears to be implicated, at least partially, in the loss of fat stores, muscle tissue, body water, and red cell mass, as well as in altered hormonal secretion and renal excretion. The stress of weightlessness is also reflected by significant increases in cortisol levels, which has widespread metabolic consequences. The occurrence of space sickness early in the flight and other vestibular disturbances manifested upon one-g recovery may be related to the headward displacement of body fluids, possible morphological changes in the vestibular apparatus, and, perhaps most importantly, conflicting cues from multiple sensory stimuli. Whatever the cause of space sickness, it is associated with a significant voluntary reduction in food and fluid consumption with the possibility of wide-ranging physiological consequences as noted above. All of these events have both acute and long-term effects which lead to the notable and consistent findings of loss in weight, change in body composition, altered blood biochemistry, decreased tolerance for orthostasis, and upon return to a one-g environment, a compromised response to physical activity.

Adaptation to weightlessness can be said to occur when the body adjusts to the primary influences of weightlessness and when the changes noted above reach a new steady-state level. Figure 1.3 is an attempt to show the relative time course of adaptation for each major physiological system. (N.B. Each system is controlled by mechanisms which vary quite widely in their speed of response. It is impossible to describe the entire range of these response times with a single curve. Figure 1.3 is intended to depict only the primary longer acting mechanisms and thus provides only a gross picture of the time course of adaptation of each system.) The time course to achieve a new state appropriate for zero-g is different for each major physiological system. The most rapid effects are observed in the vestibular system and the systems which respond to fluid volume regulation, notably the fluid-electrolyte and cardiovascular systems. At the other extreme are the body structures which respond to more slowly acting forces and which manifest their zero-g response by gross loss in red cell mass and bone calcium. However, even a slowly responding process like bone demineralization is under the control of more rapidly acting hormonal regulators. Muscle tissue appears to degrade at an intermediate rate as exemplified by nitrogen and potassium losses. The loss of blood volume is believed to occur as a result of rapid decrements in plasma volume and more gradual changes in red cell mass, thus implicating the renal-endocrine and erythropoietic systems. In addition, the long-term adaptation of the circulatory system and its ability to respond to stress may depend, in part, on the manner in which the vascular elements accommodate to the reduced blood volume. The time course of adaptation for any of these systems is, undoubtedly, a function of the nature of the disturbance as well as the effective time constant of the correcting homeostatic system.

With the possible exception of space sickness, none of the findings to date suggest that these responses to weightlessness are pathological in nature. Rather, they can be considered appropriate and effective adaptations to the weightless environment. Many of these effects can be tentatively explained in terms of normal, although complex, feedback regulatory processes.



Figure 1.3

# APPROACH TOWARD HOMEOSTASIS OF PHYSIOLOGICAL SYSTEMS DURING SPACE FLIGHT

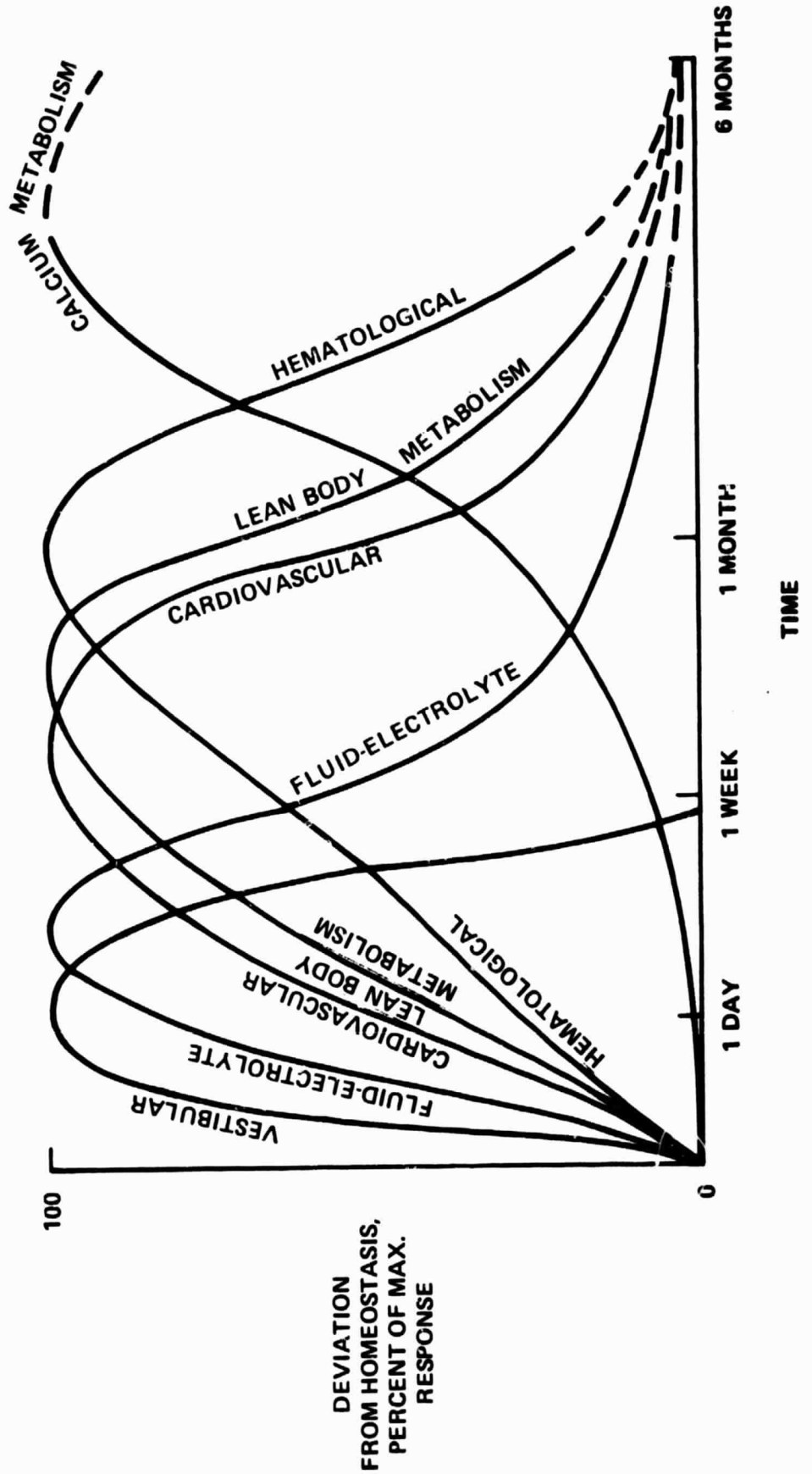

Upon return to a one-g environment, some dysfunction may appear because the functioning level of adaptation reached in zero-g is inappropriate to normal gravitational loading. However, following a short period of readaptation these changes appear reversible, at least for the time span over which man has been studied in space. The lack of detailed studies at the cellular level and the unavailability of long-duration flights in a space laboratory limit the conclusions which may be drawn regarding the long-term effects of weightlessness.

Such was the state of knowledge concerning the human response to nearly weightless space flight, as it existed just prior to the 1978 Announcement of Opportunity that led to the present SL-4 payload. What was to be expected from future experiments? What were the important issues and questions related to the human response that remained? At least two major studies were conducted in order to address such questions (see the general references given in section 1.6).

Given the limitations of a 1-week mission in examining truly long-term effects, it was obvious that the emphasis of SpaceLab research should be on the investigation of acute responses. The most pressing of these concerns were the events which lead to, and the immediate responses which follow, the translocation of blood and interstitial fluid from the lower extremities into the more cephalad parts of the body. The mechanisms by which the body accommodates this effective volume overload, and whether complete compensation occurs, were issues that needed to be examined. A second acute problem of importance was that of space sickness, which although self-limited, can seriously affect the success of short missions. The adaptation of the vestibular system, and its relationship to space sickness, was probably the least understood of the known problems of manned space flight. Experiments needed to be designed which revealed the mechanisms of space sickness and which developed means for protection against it. Investigation of these two acute effects, fluid shifts and space sickness, would require careful experimental design inasmuch as they are both marked by rapidly changing events.

Following the study of these initial disturbances, the research effort could turn to more chronic aspects of the adaptive response. It is quite feasible, during a 7-day mission, to collect meaningful data on the initial phases of long-term adaptation. Previous space studies have revealed gross changes demonstrating or suggesting cardiovascular deconditioning, respiratory alterations, negative fluid balance, unusual hormonal behavior, suppression of erythropoiesis, depressed lymphocyte activation, atrophy of muscle tissue, and demineralization of bone. Some of these disturbances need to be characterized and quantified where data are lacking, while others are ripe for the more detailed attention necessary for elucidating underlying mechanisms. More fundamental questions of gravitational biology have been suggested in the areas of genetics, developmental aspects of plants and embryos, circadian rhythms, and basic neurophysiological and vestibular function.

In 1978 it was clear that new experimental techniques, suitable for space research, must be sought to perform the required studies. Sophisticated tools for non-invasive studies should be utilized where possible, but more traditional invasive techniques which have been previously prohibited in space should be actively considered. The use of tracer techniques, indwelling

catheters, and muscle biopsies are the most obvious of these. Finally, and most importantly, it was also clear that the responsible use of animals in space research was essential in order to maintain a broad-based biological program. Initial experiments which use higher animals, including rodents and primates, ought to be carefully designed to provide validated animal models. These animals could serve as human surrogates on future missions in order to clarify physiological mechanisms.

This overview of the status of research in space physiology, although brief and admittedly incomplete, does permit some important generalizations to be made. First, it is clear that many important physiological systems are involved in the response to weightlessness. Second, these systems may be ultimately affected by only a few major influences directly attributable to weightlessness. Third, the time course of action and the response time of adaptation of each of these systems can be quite different. Fourth, these adaptations appear to be appropriate manifestations of the body to adjust to the space environment. Fifth, many important issues in all of these systems can be fruitfully addressed even on missions of short duration, assuming the proper facilities and techniques are available. And sixth, a true understanding of the behavior of any of these individual systems may not be possible without identifying and examining the interrelationships that exist between systems. Because there is such a high degree of interaction between most of the physiological systems of the body, research in space physiology must, of necessity, be considered an interdisciplinary effort.

#### 1.4 THE SCIENCE PAYLOAD, A SUMMARY

In this section, the characteristics of the individual experiments are summarized and related both to the state of knowledge that exists in a particular discipline of study and to the other companion experiments in that discipline. For convenience, the 25 experiments have been grouped into eight distinct disciplines: cardiovascular/cardiopulmonary, vestibular, renal/endocrine, hematology, immunology, muscle, calcium metabolism/bone, and gravitational biology. Table 1.1 shows the distribution of experiments and the specimen type for each discipline. In this table and the next sections, experiments are referred to by both the name of the principal investigator and an identifying number of three digits. These three digits are the last three digits of a unique six digit number assigned to each experiment submitted in response to Announcement of Opportunity OSS-1-78. The first three digits refer to that Announcement of Opportunity and are the same (781) for all the experiments discussed in this document.

##### 1.4.1 Cardiovascular/Cardiopulmonary Discipline

The cardiovascular system has perhaps the longest history among the various physiologic systems that have been studied under nearly weightless conditions. The electrocardiogram (ECG) has been monitored routinely in all crewmembers during critical launch and reentry procedures in manned space flights. Pre- and postflight studies have included measurements obtained both at rest and during orthostatic and exercise stress tests, designed to reveal gross cardiovascular and circulatory disturbances resulting from space flight. In the Skylab Program, these studies were extended to include, on a limited number of subjects, measurements during the inflight period as well. This research has provided a wealth of information on the cardiovascular response

Table 1.1  
 First Dedicated Life Sciences SpaceLab Mission  
 Proposed Payload

<u>DISCIPLINE</u>	<u>INVESTIGATIONS</u>
Cardiovascular/Cardiopulmonary	Human: Blomqvist/294, Eckberg/022, Farhi/066, West/198 Rat: Hutchins/166, Popovic/248
Vestibular	Human: Cowings/195, Young/072 Rat: Ross/238
Renal/Endocrine	Human: Leach/192 Monkey: Moore-Ede/223
Hematology	Human: Dunn/261 Rat: Dunn/012, Johnson/141
Immunology	Human: Cogoli/240
Muscle	Human: Stein/120 Rat: Baldwin/127, Ellis/303, Hoh/247
Calcium Metabolism/Bone	Human: Arnaud/305 Rat: Holton/194
Gravitational Biology	Monkey: Fuller/039 Frog: Tremor/256 Plant: Brown/236, Heathcote/054

to weightlessness, from which a composite picture can be pieced together and reasonable hypotheses can be formulated. Yet, in many instances, the underlying physiologic mechanisms are far from clear and the measurements have permitted only some inferences to be drawn. This is primarily due to the complexity of the cardiovascular system and to the central role it plays in acute manifestations of the weightlessness response. Therefore, studies of the cardiovascular system continue to have a high priority in space life sciences research.

The major inflight changes in the cardiovascular system include shifts in blood distribution as reflected by a decrease in leg volume and head congestion, decreases in circulating blood volume and hemoconcentration, a mean increase in resting heart rate, a diminished vital capacity, decreased orthostatic tolerance, and little impairment of the normal response to exercise stress up to 75 percent of maximal aerobic capacity. Measurements obtained immediately following flight indicate a diminished response to orthostasis as well as exercise, a reduced cardiac size, and a reduction of blood volume. Both flight and supporting ground-based studies have not revealed any apparent evidence of primary aberrations in cardiac function or any major circulatory control mechanisms. All cardiopulmonary disturbances have been found to be completely reversible. Cardiovascular dysfunction, to the extent noted above, can be attributed to an effective zero-g adaptation which is rendered inappropriate upon return to a one-g environment.

Efforts to understand the mechanisms of cardiovascular adaptation to the weightless condition have included ground-based studies on humans employing one-g analogs of weightlessness - supine bed rest, head-down bed rest, and water immersion - as well as computer simulations. These studies have been useful in suggesting scenarios of events occurring on the crucial first day of flight as well as hypotheses of cardiovascular adaptation yet to be tested during space flight. Invasive measurements indicating dramatic acute changes in cardiac output and venous pressures and some work using autonomic blockers have been accomplished with useful results in ground-based analog studies, but have not yet been attempted in space laboratories. It appears nearly certain that plasma volume loss occurs rapidly, is related to the initial central hypervolemia, and contributes to, but does not fully explain, reduced orthostatic and exercise tolerance postflight. The role which other mechanisms, including autonomic and hormonal factors, play in these situations is yet to be assessed. Longer term adaptation may involve adjustments which occur in both baroreceptor reflex and compliance and capacitance elements of the cardiovascular system.

Research on animals during space flight has been more limited than on humans, particularly regarding circulatory responses. The Soviet Cosmos biosatellites have apparently not included inflight cardiovascular testing in the flight animals. An early U.S. effort to obtain detailed data from a fully instrumented primate (Biosatellite) was only partially successful, but results supported the hypothesis that fluid losses may be related to headward fluid shifts, increased central pressures, and renal excretion. The one-g head-down tilt hypokinetic rat model and the lower body positive pressure primate model that have been recently developed appear to offer promising opportunities to perform detailed observations on circulatory adaptation resulting from headward fluid shifts. Studies with these models have already corroborated findings from similar head-down tilt and water immersion studies in humans.

## Flight Experiments

The flight experiments in the cardiovascular/cardiopulmonary discipline are the most ambitious of all the discipline studies proposed for this mission. Table 1.2 presents a list of the investigations selected for this discipline. A major objective of these experiments is the elucidation of the mechanisms of cardiovascular adaptation to weightlessness and re-adaptation to one-g. Particular attention will be paid to the changes in cardiovascular and cardiopulmonary functions resulting from an early and rapid fluid shift. Secondly, the validity of head-down tilt as an analog of zero-g will be tested in humans, and the head-down rat model will be tested for its accuracy in reproducing the human cardiovascular response to weightlessness. The primary objectives of all of the investigations in this discipline are listed in Table 1.3.

A wide spectrum of measurements and tests in the human will be used to assess cardiovascular function both at rest and under stress. Direct measurement of transient changes in the central venous pressure by means of an indwelling catheter inserted preflight will help establish the degree of fluid distribution and the rapidity with which it occurs. Routine measurements of indirect arterial pressure, heart rate, and ECG will be obtained. In addition, recent technological developments will permit non-invasive measurements of cardiac output and two-dimensional echocardiographic views of the heart. A bicycle ergometer and a lower body negative pressure device will be used to assess stress responses. The bicycle ergometry will include evaluation of respiratory function as well, and the orthostatic tolerance test will include measurements of regional blood flow and changes in venous compliance by the plethysmographic technique. Special attention will be devoted to evaluating the adaptation of the autonomic nervous system, particularly of those elements that control cardiac function. This includes assessment of autonomic function by pharmacological intervention and detection of changes in arterial baroreflex mechanisms by application of sub-atmospheric pressures to carotid baroreceptors. Finally, the role that gravity plays in the function of the pulmonary system will be assessed using a battery of self-administered tests that will measure a number of determinants of pulmonary gas exchange such as pulmonary blood flow, lung diffusing capacity, lung volumes, and lung tissue volume.

The cardiovascular research in rats proposed for Spacelab, although not as extensive as that in humans, offers aspects of experimentation not possible for human studies. Invasive measurements of arterial and central venous blood pressures and aortic blood flow using chronic indwelling catheters and blood flow probes could yield valuable information regarding changes in systemic macrocirculation resulting from exposure to zero-g. Microcirculatory changes will be observed using microscopic techniques on a number of rats prepared preflight with a small transparent skin and muscle back flap. The inclusion of both macro- and microscopic observations provides breadth by relating systemic vascular changes with local vascular changes. The similarity of the macrocirculatory measurements in the human and the rat experiments will permit testing of the rat as a suitable animal model for human cardiovascular adaptation to weightlessness.

Table 1.2

Proposed Dedicated Spacelab Payload  
Cardiovascular/Cardiopulmonary Discipline

Principal Investigator	Experiment Title
Blomqvist, C. Gunnar University of Texas at Dallas Experiment No. 294 Human	CARDIOVASCULAR ADAPTATION TO ZERO GRAVITY
Eckberg, Dwain L. Medical College of Virginia Experiment No. 022 Human	INFLUENCE OF WEIGHTLESSNESS UPON HUMAN AUTONOMIC CARDIOVASCULAR CONTROL
Farhi, Leon E. State University of New York at Buffalo Experiment No. 066 Human	INFLIGHT STUDY OF CARDIOVASCULAR DECONDITIONING
Hutchins, Phillip M. Bowman Gray School of Medicine Experiment No. 166 Rat	CORRELATION OF MACRO- AND MICROCIRCULATORY ALTERATIONS DURING WEIGHTLESSNESS
Popovic, Vojin P. Emory University Medical School Experiment No. 248 Rat	CARDIOVASCULAR ADAPTION OF WHITE RATS TO DECREASED GRAVITY OF SPACE SHUTTLE/SPACEFLIGHT CONDITIONS
West, John B. University of California at San Diego Experiment No. 198 Human	PULMONARY FUNCTION DURING WEIGHTLESSNESS

Table 1.3

Cardiovascular/Cardiopulmonary Discipline

Primary Experimental Objectives

Acute Fluid Shifts

- o To assess acute changes in cardiovascular function of humans and rats resulting from exposure to weightlessness; in particular, to assess the degree and rapidity of acute fluid shifts by direct measurements of central venous pressure

Cardiovascular/Cardiopulmonary Adaptation

- o To determine the time course of changes in resting cardiovascular/cardiopulmonary variables resulting from a prolonged exposure to zero-g followed by return to one-g in both humans and rats
- o To determine how acute and prolonged exposure to zero-g affects the cardiovascular/cardiopulmonary response to stress induced by exercise and lower body negative pressure (LBNP) in humans

Autonomic Mechanisms

- o To detect changes in arterial baroreflex mechanisms in humans from serial and non-invasive measurements of sinus node responses to changing levels of carotid sinus distension and to relate these changes to orthostatic intolerance in zero-g
- o To measure changes in cardiovascular response in humans to alpha and beta adrenergic stimulation using isoproterenol and phenylephrine

Pulmonary Function

- o To compare pulmonary function in humans during zero-g with that observed in one-g by a non-invasive determination of parameters related to pulmonary gas exchange

Animal/Analog Model Validation

- o To qualify the rat as a suitable flight experimental animal model for the study of the human cardiovascular response to weightlessness
- o To test the validity of 24-hour head-down tilt as an analog of zero-g in humans through comparison of inflight data with those obtained on the same crew in preflight simulation studies
- o To test the suitability of the head-down, nypokinetic rat as an animal model for human cardiovascular adaptation to weightlessness



Table 1.3 (continued)

Cardiovascular/Cardiopulmonary Discipline

Primary Experimental Objectives

Microcirculatory Observation

- o To record microcirculatory alterations during weightlessness in the rat and to relate these changes to filtration/reabsorption at the tissue level and fluid/electrolyte balance of the whole animal as well as to macrocirculatory systemic changes in the same animal
- o To observe the effects of weightlessness on the rheology of the formed elements of blood, red blood cell deformability, and white cell appearance and flow patterns in the rat and to correlate these findings with the data obtained in the hematology studies

Many of the proposed inflight measurements in this discipline will be made for the first time in space flight. These include central venous pressure and cardiac output in both humans and rats, echocardiography in humans, and arterial blood pressure in rats. Pharmacological intervention in humans and microcirculatory observation in rats are also new procedures to be attempted in space. The mass spectrometer used in the pulmonary function tests and the neck suction device used in the baroreflex tests are two examples of special equipment that will be developed especially for this flight research.

As indicated in Table 1.2, a group of six principal investigators will conduct four studies in humans and two in rats. The investigation of Blomqvist (294) involves humans and has a broad scope. Transient changes in central venous pressure in the very early phase of the flight following launch, cardiac dimensions by echocardiography, and cardiovascular response to alpha and beta adrenergic stimulation using isoproterenol and phenylephrine are some of the important new measurements included in this investigation. The human investigation of Farhi (066) is integrated into the first study and deals with the determination of cardiac output and other parameters of respiratory function through the use of a mass spectrometer. The measurement of cardiac output is based on a novel, non-invasive, indirect Fick technique employing only respiratory gases. The human experiment of Eckberg (022) will study the reflex slowing of the heart by directly stimulating the carotid baroreceptors with the use of a rigid neck cuff capable of surrounding the neck with a sub-atmospheric pressure. If this reflex is altered in weightlessness, it could provide an explanation for the reduced postflight orthostatic tolerance. This mechanical stimulation of the autonomic nervous system complements the pharmacological stimulation of the same reflex in the experiment of Blomqvist. The investigation of West (198) in this area concerns the effects of weightlessness on pulmonary function and will make use of a microprocessor coupled to a mass spectrometer. This will enable the tests to be self-administered in minutes and provide the measurements needed for a comprehensive pulmonary function assessment. Both rat experiments (Popvic/248 and Hutchins/166) have been combined and will share the same group of animals. Taken together, these two experiments provide a comprehensive study of cardiovascular adaptation to weightlessness in the rat, and complement the human experiment of Blomqvist.

In summary, these studies are designed to provide sufficient data to evaluate cardiovascular/cardiopulmonary adjustments in zero-g as well as to examine closely individual elements such as the circulatory system, the capillary beds, the autonomic mechanisms, the heart, and the lung. Where necessary, the data will be complemented by measurements made in investigations in other disciplines. For example, the chronic measurement of central venous pressure in primates (Moore-Ede/223) will be useful in assessing other wide ranging effects of the acute fluid shift. The measurement of renin activity and aldosterone levels (Leach/192) are essential in elucidating the mechanisms of longer term adaptive changes. Such complementarity of measurements from related disciplines will facilitate the description and integration of the mechanisms of cardiovascular adaptation to weightlessness.

## 1.4.2 Vestibular Discipline

Manned space flights have revealed problems in human vestibular physiology which notably manifest themselves through space sickness. Such space sickness has been reported by approximately 30 percent of the Apollo astronauts and 56 percent of the Skylab crewmembers. The symptomatology, which includes disorientation, pallor, nausea, anorexia, and vomiting, appears during the early portion of flight with full recovery, usually within 3 to 5 days of the start of a mission. These symptoms may compound other physiologic problems noted inflight by inducing dehydration, reducing food consumption, and limiting crew activity.

It is generally accepted that motion sickness on Earth involves the balance or vestibular organs of the inner ear. There are two primary theories of space sickness: the sensory conflict theory and the fluid shift theory. The sensory conflict theory, which is generally accepted, postulates that space sickness manifests itself when the central nervous system receives a sensory signal which is unfamiliar in the context of previous experience. In weightlessness, the gravity sensitive portions of the inner ear, the otolith organs, no longer provide familiar neural signals to the brain. Spatial disorientation and disturbed postural reactions to body movements are expected to occur. This theory implies that the etiology of space sickness is similar to that believed responsible for motion sickness on Earth. On the other hand, according to the fluid shift theory, space sickness results from the body-fluid shift associated with weightlessness as mediated by cerebrospinal fluid pressure effects on the central nervous system. Alternatively, the fluid shift has been proposed as a mechanism associated with a direct effect of changing pressure on the labyrinthine fluids or circulation.

There have been no early inflight experimental studies of space sickness. On Skylab provocative tests were not performed prior to the fifth day of flight. Studies performed in Skylab indicated virtually no change in the preflight and inflight measures of the perception threshold to angular acceleration; however, despite considerable space sickness early inflight, motion sickness susceptibility measured with paced head movements on a rotating chair was quite low later in the mission. While preflight and postflight tests of perceived direction of internal and external space did not reveal significant changes, crewmen reported an apparent loss of sense of awareness of body position in relation to fixed objects in the spacecraft. Russian investigators have reported inflight inversion illusion and postflight spatial orientation changes. Additional information regarding the long-term response includes temporary ataxia postflight, inflight changes in postural equilibrium remaining for up to 10 days postflight, and an increased tolerance to postflight motion sickness stimulation. Increased head and body movements inflight seem to increase the probability of space sickness. While anti-motion sickness drugs have been utilized with varying results, they are unproven at the present. The mechanisms and sites of action of these drugs are not well known.

Ground-based studies to date have included basic research into vestibular function and applied research related to space sickness. Basic research has included anatomical, neurophysiological, and morphological studies. Research related to motion sickness has been conducted utilizing a variety of techniques and equipment, including linear accelerators (sleds),

rotary chairs (rotators) and rooms, centrifuges, parabolic flights, adaptation and autonomic conditioning (biofeedback). These tools and techniques have been used to study both the sensory conflict and fluid shift theories. Data from the studies have revealed that great individual differences exist in susceptibility to and ability to habituate to motion sickness. Investigations of the primary theories of space sickness favor the sensory conflict theory, though this theory has not yet been confirmed as correct. Major aims of the applied research include development of predictors of susceptibility, as well as pharmacological and non-pharmacological countermeasures. Bed rest is currently viewed as an inadequate analog of zero-g with regards to vestibular function.

Animal studies of space sickness have not been very extensive; however, those that exist support, to some extent, a notion of adaptation of the graviceptor system in zero-g. Inflight studies of frogs (OFO-1) demonstrated increased sensitivity of the otoliths during the early phase of space flight and possible adaptive behavior, and observations of minnows in Skylab revealed disorientation through a looping response during the first 3 days in space, which diminished until complete adaptation on the twenty-first day. Russian postflight studies of rat otoconia have indicated possible changes in otoconia morphology and cytology after 16 to 20 days in space.

Major areas of space-flight research which need to be addressed in this discipline include assessing the vestibular adaptation which occurs in zero-g, determining the basic mechanisms of space sickness, investigating the current alternative theories, training crewmembers in the recognition and reporting of symptomatology, developing of effective countermeasures, and investigating possible otolith morphological changes in animals.

### Flight Experiments

This discipline is comprised of two human investigations and one animal (rat) investigation which will jointly provide a broad based study of basic vestibular function and space sickness. These are listed in Table 1.4. The primary goals of this discipline will include a multi-pronged attack on understanding vestibular adaption in zero-g, elucidating the basic mechanisms of space sickness, studying possible morphological changes, and evaluating possible countermeasures for the symptomatology of space sickness. The vestibular discipline will require data from the cardiovascular/cardio-pulmonary and renal/endocrine disciplines and by the same token, vestibular data will be available to other disciplines. Table 1.5 presents the major objectives of this discipline.

The most comprehensive experiment in this area (Young/072) includes a team of co-investigators, each of whom will provide unique contributions under the direction of the principal investigator. These investigators will study the nature of vestibular adaptation by performing an assessment of human vestibular function using several different techniques with emphasis on otolith system measurements. A major objective of this experiment will be to investigate the sensory conflict theory by studying changes in human otolith function in weightlessness and the relationship of vestibular sensitivity and stimulation to perception of orientation and space sickness. In this regard, vestibular interactions will be studied by measuring horizontal and vertical eye deviation during rotation, ocular torsion during linear and angular

Table 1.4

Proposed Dedicated Spacelab Payload

Vestibular Discipline

<u>Principal Investigator</u>	<u>Experiment Title</u>
Cowings, Patricia S. NASA/Ames Research Center Experiment No. 195 Human	A PREVENTATIVE METHOD FOR THE ZERO-GRAVITY SICKNESS SYNDROME; AUTOGENIC FEEDBACK TRAINING FOR VESTIBULAR SYMPTOMATOLOGY
Ross, Muriel D. University of Michigan Experiment No. 238 Rat	A STUDY OF THE EFFECTS OF SPACE TRAVEL ON MAMMALIAN GRAVITY RECEPTORS
Young, Laurence R. Massachusetts Institute of Technology Experiment No. 072 Human	VESTIBULAR EXPERIMENTS IN SPACELAB

Table 1.5

Vestibular Discipline

Primary Experimental Objectives

Vestibular Changes

- o To characterize possible changes in the ionic concentrations of the otoconia, the cell ultrastructure and related tissues of the neuroepithelium, and the crystal-morphology of the otoconia in the rat
- o To assess vestibular interaction between the otoliths and semicircular canals, vestibulo-visual components, and vestibulo-spinal components in humans

Perception Changes

- o To determine the loss of orientation perception in humans in regard to the sense of orientation, body perspective, and ability to move limbs accurately while blindfolded
- o To assess the ability in humans to perceive changes in velocity during rotation and acceleration

Space Sickness

- o To accurately record and characterize space sickness symptomatology and time course in humans via passive monitoring and symptom reporting
- o To characterize the effects of normal, restricted, and provocative head movements in humans on the symptomatology of space sickness
- o To assess possible changes in sickness symptomatology during LBNP and changes in susceptibility following LBNP in humans. Record symptoms of fluid shift which may relate to the onset of sickness symptomatology
- o To assess the effect of preflight autonomic conditioning on motion sickness frequency and symptomatology in humans

acceleration, leg EMG activity while falling (vestibulo-spinal reflex), and self motion perception and ocular torsion during visually induced roll. Measurements of human perceptual changes will include descriptions of orientation, positioning of body parts, location of targets while blindfolded, and velocity perception during rotation and acceleration. Investigation of human space motion sickness will be performed by passive monitoring of symptomatology and studying the effects of normal, restricted, and provocative head movements utilizing a head accelerometer/recorder with voice recordings of sickness symptomatology. Measurements of symptoms and signs will be correlated with the head acceleration record and with data on ADH and stress hormone levels obtained by other investigators. The fluid shift theory will be assessed by recording fluid shift/sickness symptomatology to determine possible correlations and by using a lower body negative pressure device to reverse any fluid shifts, thereby either reversing the symptoms or reducing sickness susceptibility. The other human experiment in this discipline (Cowings/195) will endeavor to reduce the symptomatology associated with the space sickness syndrome through preflight training. The training method will utilize two self-regulatory techniques, autogenic therapy and operant conditioning (biofeedback).

The animal experiment in this discipline, an elaborate study (Ross/238) of otoconial morphology in rats, will be conducted postflight (following an inflight animal sacrifice) to assess possible ultrastructural and functional changes. This study will explore the possibility that shifts in body fluids and changes in calcium, protein, and carbohydrate metabolism that occur in space flight cause adverse effects upon the homeostatic processes in the inner ear that ordinarily preserve ion and fluid balance, resulting in damage to the otoconial complexes. The verification of such morphological changes would be of considerable significance to current theories of sickness since terrestrial motion sickness is not associated with such changes.

#### 1.4.3 Renal/Endocrine Discipline

Throughout the manned space-flight program, there has been a continuous interest in the influence of weightlessness on the fluid regulating systems of the body. The study of body fluid volumes demands the consideration of other related areas including electrolyte regulation, circulatory dynamics, renal and endocrine function, body biochemistry, and metabolism. There are consistent findings of disturbances in most of these systems following exposure to space flight, but inflight observations of these phenomena have been limited. For convenience, this integrated multicomponent physiological entity is known as the "renal/endocrine" area of research.

The renal-endocrine response to zero-g can be conveniently divided into an acute phase (hours to days) and an adaptive phase (days to weeks). The acute phase is characterized by a significant reduction in body fluid volumes while the adaptive phase is characterized by approaches to new homeostatic levels, especially for renal excretion, endocrine secretion, body fluid volumes and composition, and losses of intracellular electrolytes. Ground-based studies have been extremely useful in providing supplementary information, especially for the acute stress phase. These useful one-g analogs of weightlessness include postural changes, water immersion, supine bed rest, head-down bed rest, and lower body positive pressure. All of these

stresses have the common characteristic of a reduction in hydrostatic gradients and a rapid headward shift of fluid. This characteristic, more than any other, is believed to be largely responsible for most of the findings during the acute response period, as well as many of the long-lasting effects.

As a result of headward fluid shifts in zero-g and central circulatory volume expansion, a complex set of reactions is believed to occur, all of which lead to a loss of extracellular fluid and electrolytes. These events include the following: a. stimulation of cardiopulmonary pressoreceptors and decreased sympathetic activity; b. increased blood pressures and secondary decreases in peripheral resistance, promoting enhanced renal blood flow; c. altered secretion of the fluid-electrolyte regulating hormones including ADH, the renin-angiotensin-aldosterone triad, catecholamines, and possibly a natriuretic agent, as well as renal prostaglandins; d. enhanced renal excretion of fluid and electrolytes as a result of the alterations in neural, endocrine, and hemodynamic influences; e. increased transcapillary filtration of plasma into the interstitium; and f. a decrease in thirst and water intake, possibly associated with altered hormone levels and augmented by space sickness anorexia. Although these mechanisms are believed to account for the frequently measured loss of plasma volume in astronauts returning from space, there is an absence of data during the first few hours of weightlessness when (according to some ground-based studies) most of the mechanisms may be fully activated. In those cases where observation of these parameters were performed later in the missions (i.e., on the three Skylab flights), the results often appear inconsistent with the model proposed above. An important facet of this model is the presence of an absolute diuresis secondary to the central fluid shifts. Previous crew measurements have not yet demonstrated an increase in renal volume excretion on the basis of 24-hour pooled urine collections. Rather, it appeared that the loss of body fluids could be accounted for by deficit fluid intake. In summary, although ground-based studies provide a strong theoretical basis for predicting pathways leading to acute volume regulation in zero-g, the short-term renal-endocrine response to space flight in well hydrated subjects is not yet known.

Although data gathering during the first day in space was previously limited by operational constraints, the three Skylab missions provided extensive data to characterize renal-endocrine status during all other portions of the flights, which lasted up to 3 months. These studies included a number of complete metabolic balances, comprehensive analysis of plasma and urinary samples, and postflight measurements of body fluid compartments. The results provided a basis for characterizing the fluid-electrolyte and hormonal responses during the long-term adaptive phase of zero-g. By the end of the first 2 days in space, the reduction in extracellular fluid and salts appears to be largely complete. The loss of other constituents takes place over a longer period of time, and during the first several weeks, significant quantities of potassium and nitrogen escape from intracellular compartments. This information has been deduced indirectly from water and electrolyte metabolic balances, although direct confirming measurements of the body fluid compartments have never been performed in space. The finding of a modest increase of water and sodium excretion throughout the adaptive phase could imply either a continued body loss of these substances, or alternatively, body balance could have been maintained by a decrease in sweat losses which offset excess excretion. The continued excess excretion of potassium and nitrogen, however, may reflect the atrophy of lean body tissue.



The role of hormonal regulators of renal function during the chronic or adaptive phase of flight is not yet clearly defined. As alluded to above, hormonal behavior of ADH, angiotensin, and aldosterone as measured in prolonged space flight is often opposite to that predicted from ground-based studies, including acute water immersion and head-down tilt and longer term bed rest. Difficult to understand is excess sodium excretion in the face of measured inflight elevations of aldosterone and increased angiotensin levels at a time when there is a tendency for central blood volume expansion. The increased urinary levels of ADH on one Skylab crew and the decreased levels on the other two flight crews has also not been satisfactorily explained. Unraveling the role of the regulators of renal-endocrine function during the adaptive phase of weightlessness and achieving a consistent hypothesis entail a closer examination of the afferent and efferent portions of each major feedback pathway. The influences of diet and circadian cycles as modifiers of these control elements are also important issues to address.

### Flight Experiments

Two comprehensive experiments have been tentatively selected to examine renal-endocrine behavior during the dedicated life sciences mission and these are listed in Table 1.6. Experimental objectives for these two experiments are summarized in Table 1.7. One of these utilizes the crew as subjects (Leach/192) and the other (Moore-Ede/223) concerns the responses of four primates (squirrel monkeys). These studies are parallel in several important respects and should result in resolving the question of whether the primate is a valid animal model for the detailed study of the renal-endocrine area. Dr. Leach is also a co-investigator of the primate study, thus assuring proper integration of the interspecies aspects of the investigation, especially with respect to blood and urine analysis. Previous limitations in space-flight research will be overcome by collecting data early inflight, by performing urine collections more frequently and in discrete fashion, by performing measurements not possible on prior flights, and by insuring that (human) subjects are adequately hydrated.

In both human and primate experiments, daily food and water consumption will be monitored, urine samples will be collected daily (4-hour pooled samples in the primate and void-by-void in the human), and blood samples will be collected intermittently throughout the mission. Extensive biochemical analyses of blood and urine will be performed postflight, including measurements of electrolytes, fluid-electrolyte regulating hormones, and protein substances (for a comprehensive list of analyses to be conducted, see Table 1.21 which appears in section 1.5). In addition, daily fecal collections will be performed on the primate in order to compute complete metabolic balances similar to those performed on the Skylab crewmembers. Daily body mass measurements will be performed on each human subject to permit inferences regarding fluid losses, dietary adequacy, and overall metabolism.

Several sets of measurements will be performed in human subjects for the first time during space flight, including those related to renal function and body fluid volumes. Renal function will be assessed, not only by measuring excretion rates, but also by tracer studies for quantifying renal plasma flow and glomerular filtration rate. Tracers will also be used to measure the three major body fluid components: plasma, extracellular fluid, and total body water.

Table 1.6  
Proposed Dedicated Spacelab Payload  
Renal/Endocrine Discipline

<u>Principal Investigator</u>	<u>Experiment Title</u>
Leach, Carolyn S. NASA/Johnson Space Center Experiment No. 192 Human	FLUID-ELECTROLYTE REGULATION DURING SPACEFLIGHT
Moore-Ede, Martin C. Harvard Medical School Experiment No. 223 Primate	FLUID AND ELECTROLYTE HOMEOSTASIS DURING SPACEFLIGHT: ELUCIDATION OF MECHANISMS IN A PRIMATE

Table 1.7

Renal/Endocrine Discipline  
Primary Experimental Objectives

Acute Fluid Shifts

- o To determine whether the circulatory and renal responses of humans and primates, immediately following the onset of weightlessness, conforms to hypotheses formulated from ground-based studies with respect to:
  - Void volume and electrolytes
  - Behavior of renal-regulating hormones
  - Renal hemodynamics
  - Biochemical changes in blood and urine
  - Circulatory pressures and heart rates

Adaptive Changes

- o To measure the extent and time course of fluid changes in the major fluid volume compartments of humans during space flight
- o To determine the nature of normal fluid and electrolyte adaptive responses in zero-g and to study the involvement of renal, endocrine, circulatory, and dietary influences in humans and primates
- o To investigate the major circadian modulation of the renal response in humans and primates and determine if weightlessness appears to modify these diurnal cycles

Validation of Animal and Ground-Based Models

- o To qualify the squirrel monkey as a suitable experimental flight animal model of human function by demonstrating comparable fluid and electrolyte balances, circulatory responses, and hormonal responses
- o To confirm ground-based models of fluid shifts during weightlessness for the human (head-down tilt) and primates (lower-body positive pressure)

In recognition of the tight coupling between renal-endocrine and cardiovascular systems, the investigators of the renal-endocrine discipline are planning to utilize a limited set of circulatory measurements. These include arterial pressure, central venous pressure, and ECG heart rate. The primates will be fitted with indwelling arterial and venous catheters and ECG electrode harnesses, and these measurements will be obtained automatically and continuously throughout the mission. Measurements in human subjects will be more limited but will include direct central venous pressure (via an in-dwelling catheter inserted preflight) collected intermittently during the first 8 hours of flight and indirect arterial blood pressure and ECG heart rate measured at least once each day. Responsibility for these human measurements resides with a cardiovascular experiment (Blomqvist/294).

The animal studies are designed to collect data with a minimum of crew involvement. The primate cages will automatically control and/or monitor light-dark cycles, gross motor activity, food and water consumption, and collect 4-hour pooled urine samples. The indwelling catheter will be used both for automatic measurement of blood pressures and for collection of blood samples without the need to move the animals from their restraint harnesses.

These two experiments are designed to examine the mechanisms responsible for adjustments in fluid and electrolyte homeostasis during both the acute (first day) and adaptive phases of the mission. The conceptual model which accounts for the rapid loss of extracellular fluid will be evaluated for the first time during space flight and concurrently in humans and primates. Circulatory mechanisms will be assessed by changes in blood pressures, particularly venous pressure; heart rate and catecholamine levels will indicate sympathetic activity; the dynamic behavior of important renal regulating hormones will be observed by multiple blood samples, and renal function will be determined directly by clearance studies and collections of each urine void. In this way, the relative influence of the major pathways available for correcting rapid volume disturbances in zero-g can be evaluated. Similar measurements will be performed at other times later in the mission to assess the rate of adaptation during the 7-day space exposure. By this means it is hoped to resolve some of the puzzling aspects of endocrine adaptation. In addition, body fluid volume studies in humans will be conducted to test the hypothesis that these compartments tend to equilibrate within several days of flight. The requirement for collecting frequent urine voids affords the unique opportunity to observe circadian rhythms in the urinary constituents in both humans and primates under the same conditions and to investigate circadian modulation of the renal response to cephalad fluid shifts.

Supporting ground-based studies for these experiments include head-down tilt for human subjects and lower body positive pressure for primates. The inflight data will be used to confirm these one-g models for their applicability to study fluid shifts during weightlessness.

#### 1.4.4 Hematology Discipline

The single most important hematological finding of significance to space flight is a reduction in the circulating red cell mass during the flight interval. Explanations for this phenomena have been proposed, but confirmatory evidence is still lacking. The working hypothesis prior to Skylab was that the pure oxygen atmospheres in the space capsule represented a

toxic stimulus and resulted in early death of significant numbers (up to 20 percent loss) of red cells. For the Skylab crew who lived in a supposedly normoxic environment, this hypothesis was no longer tenable to explain their average loss of 10 percent of total red cell mass. In the absence of a consistent finding of increased red cell destruction and in the light of an observed reduction in reticulocytosis upon return from space, it is now assumed that the loss of red cell mass was likely a result of suppressed erythropoietic activity. However, no conclusive proof of this is available based on inflight measurements, and no one mechanism has been identified which is consistent with all the data. The concept, proposed after the Skylab program, that red cell mass will eventually recover following an initial decline, does not appear to be supported by data from Russian manned flights of 6 months duration.

Decrements of red cell mass have been observed during human bed rest studies and in dehydrated mice. Computer simulations of a mathematical model of erythropoiesis have also been useful in developing concepts of feedback control and in integrating and interpreting data from a variety of sources. Collectively, these one-g and zero-g findings have been valuable in identifying etiological factors and testing various hypotheses. According to current concepts, a reduced erythropoietic state can be caused indirectly by hyperoxia of a renal oxygen sensor via the humoral regulator, erythropoietin, acting on the bone marrow, or by direct alteration of stem cell kinetics at the marrow controller. (The existence of erythropoietin inhibitors should also be considered.) Tissue hyperoxia may be caused by factors which increase oxygen supply (i.e., hemoconcentration, enhanced blood flow, decreased oxy-hemoglobin affinity, and increased arterial oxygen loading), or by factors which decrease oxygen demand. Proliferation of erythroid precursors at the bone marrow level is affected, not only by erythropoietin, but also by dietary (protein and caloric) factors. One can reasonably postulate that all of these various influences were present to various degrees during space flight and bed rest, and that they contributed to the eventual reduction in red cell mass. Neither their absolute or relative influences are known, however.

Only limited inflight blood analyses have been conducted, and these have not included measurements of parameters which quantify either red cell mass or red cell production. More extensive studies are required, particularly for the inflight period. It is not clear whether gross changes in red cell mass may be detectable in Shuttle missions of short duration in a one atmosphere, normoxic environment. However, various measurement techniques are available which could reveal expected alterations in erythropoietin or red cell production should they occur. It would also be desirable to control dietary intake in some manner as the influence of this parameter on red cell loss of the Skylab crew has been suggested. Animal studies would permit more invasive and time-consuming studies to be performed. However, the validity of animals as human surrogates for hematological studies in zero-g has yet to be established.

### Flight Experiments

The hematological discipline is represented by several experiments, listed in Table 1.8, designed to address the most critical issues concerning the "anemia of space flight." This discipline consists of a human study and two animal (rodent) studies. One of the two principal investigators of these

Table 1.8  
Proposed Dedicated Spacelab Payload  
Hematology Discipline

Principal Investigator	Experiment Title
Dunn, C. D. R. Baylor College of Medicine at Houston Experiment No. 012 Rat	REGULATION OF ERYTHROPOIESIS DURING SPACEFLIGHT
Dunn, C. D. R. Baylor College of Medicine at Houston Experiment No. 261 Human	INFLUENCE OF SPACEFLIGHT ON ERYTHROKINETICS IN MAN
Johnson, P. C. NASA/Johnson Space Center Experiment No. 141 Rat	REGULATION OF BLOOD VOLUME DURING SPACEFLIGHT

studies (Dunn) will be in charge of the human study as well as one of the animal studies. The other animal study will be performed by an investigator (Johnson) who was a lead hematologist during the Apollo and Skylab programs. The experimental objectives of these investigations are summarized in Table 1.9. In addition, a primate hematology study which consists of a limited blood analysis will be conducted using existing resources (Moore-Ede/Dunn). Integration of these experiments is also reflected by a parallel experimental design for the human and animal studies and by the two animal studies sharing the same flight animals. A common framework for analysis and interpretation of ground-based and flight data will be provided by the use of a single computer model of erythropoietic control.

Compared to previous studies concerned with the loss of red cell mass in astronauts returning from space, these experiments will gather considerably more data during the periods of weightlessness, they will more thoroughly examine mechanisms which may contribute to the loss of red cells in a more thorough manner, and they will include flight animals to specifically study their hematological responses for the first time in a U.S. space mission. The objectives of the hematological discipline may be categorized into three broad areas: a. to document blood volume losses during and following the flight; b. to quantitatively examine several important pathways by which it is believed erythropoiesis may be suppressed and to test whether red cell destruction is abnormal; and c. to provide a number of comparable measurements in humans and rats to determine if the zero-g rat response is a valid model of the human zero-g response.

Blood volumes will be measured directly pre- and postflight using appropriate tracers for red cell mass and plasma volume. During the inflight phase, blood volume will be assessed indirectly by measuring plasma volume and hematocrit. (The determination of plasma volume in human subjects will be performed by the renal-endocrine study.) The size of the circulating red blood cell compartment (red cell mass) represents the balance between the rate of red cell production and the rate of red cell destruction. Both terms of this equation will be studied in some detail. Two of the most widely used measures of red cell production will be employed in both humans and rats: iron incorporation in newly formed cells and reticulocyte counts. Various mechanisms which could lead to the expected suppression in red cell production will be examined, including hemoconcentration, a reduction in circulating levels of erythropoietin, an increase in hemoglobin P<sub>50</sub>, ineffective erythropoiesis, changes in red cell morphology, and decreases in body mass. In addition, human and rat blood will be examined for the presence of erythropoietin inhibitors, and the ability of the flight animal's hemopoietic tissue to respond to erythropoietic stimuli will be tested. Blood collected from both species during pre-, in-, and postflight phases will undergo extensive analysis to assess whether serum and red cell constituents are altered during or after exposure to weightlessness. These analyses include complete blood counts; red cell indices; reticulocyte age classification; 2,3-DPG; red cell ATP; hemoglobin; iron binding proteins and enzymes; and electrolytes. Whether or not red cell destruction plays a role in the loss of red cell mass will be evaluated by red blood cell survival studies using labelled cells, injected preflight, in both humans and rats and by analysis of human blood for evidence of hemoglobin breakdown, e.g., haptoglobin and bilirubin.

Table 1.9  
Hematology Discipline  
Primary Experimental Objectives

Blood Volume Loss

- o To determine if red cell mass, measured postflight in the human and the rat, exhibits the reductions expected from previous space flight studies
- o To measure the plasma volume in humans and rats by direct techniques and determine its dynamic behavior during the course of the flight
- o To determine whether hemoconcentration develops during flight due to an expected rapid decrease in plasma volume; to compare its extent and time course in both humans and rats

Mechanisms Leading to Decreased Red Cell Mass

- o To test the assumption that reduction in red cell mass previously observed following space flight is due to suppression of normal erythropoiesis by measuring red cell production during flight in humans and rats
- o To investigate the role of specific mechanisms in humans and rats which could account for the "anemia of space flight":
  - Reduced plasma erythropoietin
  - Erythropoietin inhibitors
  - Shifts in oxygen-hemoglobin affinity
  - Hemoconcentration
  - Nutritional status; negative energy balance
  - Decreased body weight
  - Shortened RBC life span
  - Ineffective erythropoiesis
- o To determine if an erythropoietic system (in the rat) suppressed by space flight can be stimulated postflight by using:
  - In vivo response to hypoxic exposure
  - In vitro response of erythropoietin-responsive cell cultures

Validation of Animal Model

- o To qualify the rat as a suitable experimental animal model for studying the human erythropoietic response to weightlessness. Comparable measurements are proposed for red cell mass, plasma volume, hematocrit, red cell production, erythropoietin, P<sub>50</sub>, body mass, red cell survival, and routine blood indices



Table 1.9 (continued)

Hematology Discipline

Primary Experimental Objectives

Validation of Animal Model (continued)

- o To test the suitability of the head-down, hypokinetic rat as an animal model for erythropoietic adaptation to weightlessness
- o To directly assess the relevance of a large amount of information obtained from water-deprived rodents to the erythropoietic effect of space flight

The two animal experiments are somewhat similar, and as stated above, they share the same group of flight animals so that procedures may be combined. The major difference in the inflight experimental design is that Johnson requires determination of body mass, while Dunn asks for more elaborate measurements (i.e., plasma volume, iron uptake, hematocrit,  $P_{50}$ , reticulocyte index, and red cell shape). Dunn is also requesting tissues from the inflight animal harvest, including blood for additional measurements (such as hemoglobin and erythropoietin) and bone marrow and spleen tissues for culture analysis. Finally, in order to relate erythropoiesis to nutritional and hydration status, Dunn is also interested in carefully monitoring body mass, food consumption, and water consumption. These investigators will be conducting two interesting postflight studies to assess the responsiveness of the hemopoietic tissues of the rat (bone marrow and spleen) following exposure to zero-g. An in vivo test is planned by Johnson in which he will study red cell production in flight animals exposed to altitude hypoxia for 3 consecutive postflight days. Dunn's assessment consists of testing the in vitro response to administered erythropoietin of cultures prepared from the marrow and spleen of sacrificed flight animals. This information will support other data designed to test the assumption that erythropoietic function is suppressed.

As a result of these studies, it will be possible to evaluate the rat as a suitable human model in several important aspects including the expected decrements in plasma volume, red cell mass, red cell production, and erythropoietin. Also, comparable measurements in red cell survival, red cell morphology, iron kinetics, and serum chemistries should provide clues to species differences, if any. Several experimental models for the one-g simulation of the hematological responses to weightlessness will be tested using the flight data, including the dehydrated mouse, the head-down, hypokinetic rat, and the lower body positive pressure monkey.

The experimental protocol essentially involves two procedures, blood collection and tracer injection. Several tracers will be administered:  $^{51}\text{Cr}$  for red cell mass and red cell survival,  $^{59}\text{Fe}$  for red cell production, and  $^{125}\text{I}$  for plasma volume. Intermittent blood collection is required to establish a preflight baseline, a longitudinal study of adaptation during the 7-day mission, and a postflight recovery response. There is some concern that excessive volumes of blood drawn for sampling might interfere with the primary response to weightlessness. This problem will be minimized in the animal studies by using different rats for each blood draw series and by re-infusion of red cells in the primate. Insofar as human studies are concerned, the problem will be addressed by using micro-sampling techniques wherever practical and by performing ground-based tests to assess the effects of blood sampling on hematological parameters.

#### 1.4.5 Immunology Discipline

Space-flight data regarding the human immune response to weightlessness have been ambiguous, since the effect of weightlessness itself is difficult to separate from the stress of recovery. Studies of the reactivity of the lymphocytes, the cells responsible for the immune response, have produced varying, conflicting results. During the Apollo missions, lymphocytes were studied both before and after flight. Though the data were not entirely consistent, no significant effect was observed in DNA and RNA

synthesis measured in phytohemagglutinin (PHA) activated cells. In similar tests during Skylab, there was initially a decreased response to PHA when RNA synthesis was measured. Three days after incubation, the effects on DNA-synthesis were less evident, and within 1 to 2 weeks after recovery, the lymphocytes had returned to preflight levels. Studies from the Apollo-Soyuz flight and the Russian Soyuz flight also indicated a decreased postflight responsiveness of lymphocytes to mitogens. Other changes which have been observed postflight during various missions have included varied plasma immunoprotein concentrations and elevated white blood cell counts. Information from Cosmos revealed a decreased rat thymus and spleen size. While the data are at least partially contradictory in nature, it does suggest some influence of space flight on lymphocyte reactivity, including a postflight decrease in responsiveness. Recent operational medical data from STS-1 demonstrated a clear, statistically significant decrease in the in vitro ability of lymphocytes to respond to a mitogenic challenge postflight. These data suggest a transient suppression of lymphocyte response and lymphocyte numbers immediately postflight. The overall effects on immunological function are unclear.

### Flight Experiment

The primary goal of the immunology discipline is to characterize the effect of weightlessness on lymphocyte proliferation. The single experiment in this discipline, which is listed in Table 1.10, will investigate in vitro the effect of human lymphocyte activation in order to establish possible alterations of the cells responsible for the specific human immune responses during long-term space flight. The major objectives are presented in Table 1.11 and include studying the effect of stress and the effect of weightlessness per se on lymphocyte activation, the kinetics of lymphocyte proliferation in space, and the effect of a gravitational environment between zero-g and one-g on lymphocyte function. The lymphocytes will be exposed to specific mitogens such as concanavalin A so that it will be possible to distinguish between the effects on the T- and B-lymphocytes cell proliferation, protein biosynthesis, and cell ultrastructure. The stimulation of lymphocytes will be assessed by their incorporation of tritiated thymidine into DNA. Protein synthesis will be measured by the incorporation of <sup>14</sup>C-leucine and postflight analyses of cell ultrastructure will be accomplished via electron microscopy. The results of this investigation should allow a prediction on the efficiency of the natural defense mechanisms against infections in space.

#### 1.4.6 Muscle Discipline

A significant amount of human muscle atrophy has been noted to occur in response to space flight. Specific changes include a loss of lean body mass, decreased muscle mass in the calves, and decreased muscle strength. The major muscle loss is believed to be associated with anti-gravity (postural) muscle. Despite an adequate protein intake, the effects of space flight appear analogous to those of the fasting state whereby muscle protein is broken down to its constituent amino acids. Space-flight studies in this area have included inflight metabolic balance studies, analysis of urinary amino acids, and development of exercise programs to prevent strength loss in specific muscle groups. Results of these investigations suggest an increased protein catabolism, including muscle breakdown. The data indicate negative

Table 1.10  
Proposed Dedicated Spacelab Payload  
Immunology Discipline

<u>Principal Investigator</u>	<u>Experiment Title</u>
Cogoli, Augusto Swiss Federal Institute of Technology Experiment No. 240 Human	LYMPHOCYTE PROLIFERATION IN WEIGHTLESSNESS

Table 1.11

Immunology Discipline  
Primary Experimental Objectives

Acquired Immunity

- o To determine the effect of weightlessness versus stress on lymphocyte activation
- o To characterize altered lymphocyte proliferation kinetics
- o To determine the effects of intermediate gravitational environments on lymphocyte function

nitrogen and potassium balances and increased total urinary amino acids. The most significant loss of nitrogen has been noted to occur during the first month of flight and appears partially independent of exercise (Skylab). Cosmos data have revealed that the rat soleus muscle is susceptible to hypogravity atrophy, with 32 percent reduction in weight and a 22 percent reduction in cross-sectional area. Ground-based investigations have included supine bed rest in humans and hind limb immobilization in rats with results that correlate with those space-flight studies.

A central issue requiring clarification is whether the negative nitrogen balance which occurs during weightlessness is due to decreased protein synthesis or increased protein breakdown. Other areas that need to be studied include the determination of the level and turnover rates of individual amino-acids in the plasma, and the identification of the muscle fibers affected by exposure to zero-g.

### Flight Experiments

The muscle discipline is comprised of one human and three rat studies, as shown in Table 1.12. The areas of investigation in this discipline, which are listed in Table 1.13, will include the study of the increased nitrogen loss in humans and parallel studies in rats. These latter studies will include extensive biochemical and morphological assessments of changes in the slow-twitch (antigravity) and fast-twitch muscles. Many of the measurements in these studies will be performed for the first time in flight.

The human study (Stein/120) seeks to establish whether the nitrogen loss is due primarily to decreased uptake and production of protein or to increased mobilization and metabolism of muscle proteins. The effect of zero-g on human whole-body protein metabolism will be studied using <sup>15</sup>N-glycine as a tracer for protein metabolism. Muscle protein breakdown will be measured by determining the rate of excretion of 3-methyl histidine in the urine. Plasma protein synthesis will be measured from the incorporation of <sup>15</sup>N-glycine in the various proteins and the rate of hemoglobin synthesis will be determined from the amount of <sup>15</sup>N-glycine in the hemoglobin. The urinary excretion of hydroxyproline, hydroxylysine, and their glycosides will be utilized to assess collagen breakdown.

The rat studies parallel the human experiment in the assessment of metabolic changes, but include, in addition, morphological studies of muscle and nerve fibers and biochemical analyses of various proteins. These studies will obtain tissue samples from shared animals with both inflight and postflight animal sacrifice. One investigation (Baldwin/127) will seek to determine whether weightlessness causes a reduced capacity for oxidative metabolism in skeletal muscle, particularly the fast and slow twitch hind-limb muscles, leading to a greater dependence on the anaerobic energy expenditure of glycogen, ultimately limiting endurance capacity. The oxidative capacity of muscle homogenates, and alterations in tissue glycogen and mitochondrial and glycogenolytic enzymes will be determined postflight in both rested and exercise animals. Skeletal myosin isoenzymes will be analyzed in another experiment (Hoh/247) in order to determine if there are decreases in slow-twitch muscle fiber isoenzymes, thus resulting in muscle alterations toward the fast-twitch muscle type. It is expected that in zero-g, neural stimulation of the slow-twitch fibers will be minimal and that the isoenzyme

Table 1.12  
Proposed Dedicated Spacelab Payload  
Muscle Discipline

Principal Investigator	Experiment Title
Baldwin, Kenneth M. University of California at Irvine Experiment No. 127 Rat	EFFECT OF ZERO-GRAVITY ON BIOCHEMICAL AND METABOLIC PROPERTIES OF SKELETAL MUSCLE
Ellis, Stanley NASA/Ames Research Center Experiment No. 303 Rat	ELECTRON MICROSCOPY, ELECTROMYOGRAPHY, AND PROTEASE ACTIVITY OF RAT HIND-LIMB MUSCLES
Hoh, Joseph F.Y. University of Sydney Experiment No. 247 Rat	SKELETAL MYOSIN ISOENZYMES IN RATS EXPOSED TO ZERO-GRAVITY
Stein, Thomas P. University of Pennsylvania Experiment No. 120 Human	PROTEIN METABOLISM DURING SPACEFLIGHT

Table 1.13

Muscle Discipline

Primary Experimental Objectives

Protein Metabolism (Human Only)

- o To characterize the nature of the loss of body nitrogen during space flight, including
  - Whole body protein metabolism
  - Muscle protein breakdown
  - Plasma protein synthesis
  - Hemoglobin synthesis
  - Collagen breakdown

Electromyography (Rat Only)

- o To correlate the EMG activity patterns of the antigravity muscle with the patterns of animal movement

Muscle Tissue Analysis (Rat Only)

- o To determine the nature of muscle atrophy in weightlessness by morphological, histological, and biochemical studies of fast-twitch and slow-twitch muscle groups and of myelinated nerve fiber
- o To examine enzymatic alterations in muscle after exposure to weightlessness by studying changes in proteolytic, glycogenolytic, and mitochondrial enzymes and in muscle myosin isoenzymes
- o To determine whether slow-twitch antigravity muscle will tend toward fast-twitch muscle
- o To define in histological and biochemical terms the extent of trauma due to launch and reentry stress upon skeletal muscles
- o To determine if weightlessness causes alterations in body carbohydrate stores, endurance capacity and oxidative metabolism in skeletal muscle



pattern will be altered accordingly. Preflight and postflight body weight will be recorded, inflight activity will be monitored, and postflight tissue analyses will determine myosin-isoenzyme profiles. The third study (Ellis/303) will investigate slow-twitch and fast-twitch muscles for anatomic changes as a consequence of atrophy in the zero-g environment. The biochemical and histochemical nature of atrophy will be characterized by studying the proteolytic and mitochondrial enzymes of the muscles. Alterations in the activity patterns of the antigravity muscle prior to and during flight will also be monitored by utilizing EMG patterns and correlating the patterns to animal movement as measured through video records and Research Animal Holding Facility (RAHF) activity patterns. In addition, the morphological, biochemical, and histochemical changes in the anti-gravity muscles and nerves will be determined in regard to launch stress, inflight atrophy, reentry stress injury, and late postflight repair.

#### 1.4.7 Calcium Metabolism/Bone Discipline

Perhaps the most serious health hazard of long-term space flight thus far documented is a progressive loss of skeletal mass. This abnormality is associated with significant changes of calcium homeostasis as evidenced by increased urinary and fecal excretion of calcium. Both prolonged exposure to zero-g and long periods of immobilization in normal subjects have been shown to produce a persistent negative calcium balance. The available data give some indication of the magnitude of skeletal loss and describe some observations concerning possible cellular and hormonal mechanisms involved. However, the most fundamental questions concerning the mechanisms of bone loss in space flight are yet to be answered and need further investigation.

Much of the information we have on bone metabolism in individuals exposed to zero-g is derived from data obtained during the three manned Skylab missions. In addition, the earlier U.S. flights, Gemini and Apollo, and Russian Soyuz flights have provided some data on space-flight changes in calcium balance. During Skylab, a rapid increase in urinary calcium excretion was detected, which began soon after entry into a weightless environment and which persisted throughout the space flight. On the longest Skylab mission of 84 days, the increase in urinary calcium excretion was accompanied by a rise in fecal calcium loss, due in part, perhaps, to a progressive loss in net intestinal calcium absorption. Besides increased calcium excretion, progressive losses of nitrogen, phosphate, potassium, and muscle mass are known to occur in space flight. The limitations of extended duration space flight imposed by continued musculoskeletal loss are evident from these data. Efforts to avoid skeletal wastage through exercise regimens have not been successful, and it has not been possible to reverse inflight calcium or nitrogen loss.

Ground-based bed rest studies have shown changes in calcium balance and skeletal mass similar to those observed in space flight. The loss of calcium and bone has persisted in bed-rest experiments ranging up to 36 weeks in duration. Earlier studies, based on isotope kinetics, were interpreted to mean an increase in bone formation and an even larger increase in bone resorption to account for the decrease in body calcium. However, more recent histological data indicate a decrease in bone formation, which together with a postulated (and unexplained) increase in bone resorption leads to a rapid loss of bone. We do not know the extent to which this is true in space flight because of insufficient data. There have been no calcium kinetic and histological studies performed in man in space.

With regard to animal studies, data from rats flown on Russian Cosmos flights have indicated a decrease or even cessation of bone formation. This is in agreement with observations in immobilized rats under one-g conditions. However, bone resorption has not been found to increase in space flight in contrast to the findings in immobilization. Direct measurements show maintenance of normal levels of resorption in young growing rats early in the flight and subsequent decreases which appear to be secondary to decreased calcium turnover rate.

In the light of the available information, it is not clear whether the normal adjustments to gravitational and muscular stress are primarily due to changes in the activity of osteoblasts that form bone, or osteoclasts that resorb it. It is likely that both cell types are involved. The results of ground-based studies in humans and animals and the results of space flight studies in rats are only partially in agreement and clearly point to the need for further investigation in this area. Although it seems reasonable to assume that the skeletal loss in weightlessness is directly due to the lack of a gravitational force on the skeleton, the regulatory role of hormonal factors cannot be excluded. Endocrine studies in space flight and immobilization are relatively few, and the data are in considerable conflict. Therefore, in addition to kinetic studies, the biological activities of regulating hormones such as parathyroid hormone (PTH) and calcitonin and those of the active metabolites of vitamin D in zero-g need to be studied.

### Flight Experiments

Although significant bone loss may not occur in a short 7-day mission, the antecedent endocrine events are likely to be evident during the early days following the onset of weightlessness. New experiments proposed for the present SL-4 mission are listed in Table 1.14. They include inflight calcium kinetic studies in both humans and rats, calcium balance studies in rats, and measurements of calciotropic hormones in humans. Proposed postflight studies in rats are aimed at determining the changes in bone formation and resorption resulting from weightless exposure. The primary experimental objectives are listed in Table 1.15.

Of the two experiments in this area, one involves human subjects (Arnaud/305) and will use two stable isotopes of calcium,  $^{40}\text{Ca}$  and  $^{48}\text{Ca}$ , to determine if the elevation of fecal calcium is due to decreased gastrointestinal absorption or to active gastrointestinal excretion. If, indeed, the gastrointestinal absorption is suppressed in zero-g, it will have an important steering effect on future space research in the area of bone metabolism. Also included in the human experiment is the inflight measurement of circulating levels of parathyroid hormone, calcitonin, vitamin D metabolites, serum phosphorus, and serum protein. This measurement will be made twice during the flight, once early and once later. The measurements will help identify the endocrine changes that may be responsible for the ensuing bone loss.

The other investigation on the effects of weightlessness on bone metabolism uses rats (Holton/194) and involves an inflight calcium tracer study with  $^{40}\text{Ca}$  administered continuously through the diet and recording of food and water consumption and collection of waste trays. Postflight studies include determination of calcium turnover rate, osteoblast and osteoclast

Table 1.14

Proposed Dedicated Spacelab Payload  
Calcium Metabolism/Bone Discipline

<u>Principal Investigator</u>	<u>Experiment Title</u>
Arnaud, Claude D. University of California at San Francisco Experiment No. 305 Human	PATHOPHYSIOLOGY OF MINERAL LOSS DURING SPACEFLIGHT
Holton, Emily M. NASA/Ames Research Center Experiment No. 194 Rat	BONE, CALCIUM, AND SPACEFLIGHT

Table 1.15

Calcium Metabolism/Bone Discipline

Primary Experimental Objectives

Calcium Metabolism

- o To determine the changes in turnover, intestinal absorption, and excretion of calcium in humans and rats during space flight
- o To measure changes in circulating levels of calcitropic hormones in humans due to weightless exposure
- o To determine if positive calcium balance in rats is restored upon return to one-g

Bone Growth and Homeostasis

- o To determine the changes and the time of onset of changes in bone formation and bone resorption and intestinal absorption of calcium in rats during space flight
- o To determine if bone formation or bone resorption predominates in total skeletal calcium turnover in rats
- o To determine if bone growth in rats is restored to preflight levels upon return to one-g

activities and morphological examinations. The bone morphology will be studied using computer-aided microscopy.

The consequences of bone loss in space flight that are of concern include (1) the possibility of irreversible bone loss, (2) the possible toxic effects of calcium and phosphate released from bone on soft tissues, and (3) the functional hazard of a diminished skeletal mass. They underscore the importance of resolving the issues related to changes in bone growth in a weightless environment. The data from the proposed flight experiments on calcium metabolism and bone changes will help delineate further the similarities and the differences between space flight and immobilization and thus improve our understanding of the mechanisms of bone loss in zero-g.

#### 1.4.8 Gravitational Biology Discipline

The discipline of gravitational biology includes those areas of life sciences research which address questions of fundamental biological significance not directly related to the major functional systems included in the other separate disciplines. Among the problems studied in this discipline are those that concern gravitropic and phototropic responses of plants, embryogenesis and organogenesis in animals, and temperature regulation and circadian rhythms in primates.

U.S. space research with plants has been much less extensive than animal research and has concentrated on either the survival and mutability of plant seeds in weightlessness, or with cosmic ray effects. Only a few studies have been concerned with fundamental questions of plant growth and development in weightlessness. It is well known that all green plants have developed control systems which insure that their organs (roots, stems, leaves, etc.) assume an orientation appropriate to their function. The control system acts to correct any deviations from the normal growth direction of a shoot by modulating growth rates on opposite flanks of the shoot to bring about a corrective bending. It is also clear that such plants possess a gravity sensing (geotropic) mechanism as well as a light sensing (phototropic) mechanism. It is easy to study the pure geotropic response of plants in the laboratory by turning the lights out, but the mechanism underlying this well-studied response still remains a mystery. On the other hand, pure phototropic behavior cannot be obtained on the surface of the Earth, since gravity is always present, and, thus, has never been studied.

Ground-based studies in plant developmental biology have included both clinostat studies, which attempt to model microgravity, and centrifuge studies, which examine the effects of higher than normal gravity loads. Clinostat studies have suggested that microgravity produces no substantial changes in growth and overall physiology, but that plant orientation is significantly altered. Centrifuge studies have demonstrated an inverse relationship between transverse G-stimulation (stimulus intensity) and the stimulus duration required to achieve a given, standardized response. This Reciprocity Rule has been demonstrated to hold over a wide stimulus range. Biosatellite studies of the growth of wheat and pepper plants have confirmed the results of the ground-based clinostat experiments, but have not extended them.

The role that gravity plays in the stages of embryological development in the frog was the subject of two experiments in the Gemini series and one experiment in the Biosatellite program. The results of these experiments showed no effects of weightlessness on the frog's developmental process. However, all data for these studies were collected using embryos that had undergone several cell divisions prior to launch, whereas the critical period, in so far as gravity is concerned, may be during and shortly after fertilization. This is because, at this time, the egg rotates due to a polarized distribution of heavier yolk material and the bilateral symmetry first becomes evident (even before the first cleavage). Neither ground-based centrifuge studies in hypergravity, nor studies with mechanical re-orientation of frog eggs, have clarified the role of gravity in embryological development.

Little data on thermoregulation and circadian rhythms in animals or man have been collected in space. An exception to this occurred on the Biosatellite 3 flight where such data were collected from a primate. In this case, the primate showed a gradual decline in body temperature and a non-24-hour period of the temperature rhythm in the presence of a 24-hour light/dark cycle. In addition, the rest/activity cycle for the animal remained synchronized to a 24-hour period with a phase shift relative to the light/dark cycle. These results suggest that reductions in gravity may have an influence on patterns of primate circadian rhythms, and, in turn, on homeostatic capacity during an interim transition period. Ground-based studies have demonstrated that a number of extrinsic or environmental factors such as noise, light intensity, vibration, and acceleration can modify the phase, mean, or period of various of the daily rhythms, including the temperature rhythm. Centrifugation studies have shown that hypergravity leads to numerous thermoregulatory changes in the primate, including a decrease in mean body temperature and a cessation of body temperature rhythm for several days. Experimental evidence demonstrates that the controlling system in primates which regulates circadian rhythms is composed of at least two central pacemakers, one of which controls body temperature rhythms. A second and separate pacemaker generates circadian rhythms in feeding, drinking, and activity levels. Normally, these pacemakers and all of the body rhythms are in internal synchrony. Extrinsic factors may influence these two internal systems in different ways, producing desynchronization among the various rhythms which, in turn, might compromise the primate's ability to regulate temperature in the usual precise fashion.

### Flight Experiments

For the dedicated Spacelab mission, there are four experiments which investigate fundamental problems of gravitational biology and these are listed in Table 1.16. Two of these studies involve plants (Brown/236, Heathcote/054); one involves frogs (Tremor/256), and one involves squirrel monkeys (Fuller/039). The primary objectives for these experiments are summarized in Table 1.17. The two plant experiments are scientifically complementary and they share much of the same flight hardware, but the other two experiments exhibit little overlap with each other or with the plant experiments. Thus, this discipline could be considered as composed of three nearly orthogonal components, each contributing separately to the scientific content of this mission. Their unity lies in the ultimate unity of all life sciences or biological experimentation, and, in a broad sense, these experiments are truly complementary.

Table 1.16

Proposed Dedicated Spacelab Payload

Gravitational Biology Discipline

Principal Investigator	Experiment Title
Brown, Allan H. University of Pennsylvania Experiment No. 236 Plant	DETERMINE PROPERTIES OF THE GRAVITROPIC RESPONSE OF PLANTS IN THE ABSENCE OF A COMPLICATING G-FORCE
Fuller, Charles A. University of California at Riverside Experiment No. 039 Primate	THERMOREGULATION IN PRIMATES IN THE SPACE ENVIRONMENT
Heathcote, David G. University College of South Wales Experiment No. 054 Plant	POST ILLUMINATION ONSET OF NUTATION AT ZERO-GRAVITY
Tremor, John W. NASA/Ames Research Center Experiment No. 256 Frog	THE EFFECT OF WEIGHTLESSNESS ON THE DEVELOPMENT OF AMPHIBIAN EGGS FERTILIZED IN SPACE

Table 1.17

Gravitational Biology Discipline  
Primary Experimental Objectives

Primate Temperature Regulation and Circadian Rhythms

- o To characterize the physiological regulation of body temperature in squirrel monkeys during space flight
- o To characterize the internal synchrony among key variables related to the circadian timekeeping system (temperature, heart rate, food and water consumption) during space flight
- o To characterize the external synchrony of the circadian timekeeping system during space flight with a 24-hour environmental time cue

Amphibian Embryogenesis and Organogenesis

- o To determine the effect of weightlessness on fertilization, bilateral symmetry determination, and early development
- o To characterize the effect of weightlessness during fertilization and early development on the gravity-sensing components of the vestibular apparatus
- o To characterize the effect of weightlessness during fertilization and later development at one-g through metamorphosis and subsequent inbred generations

Gravitropic and Phototropic Responses of Plant Seedlings

- o To characterize the kinetic features of the gravitropic bending of a plant shoot in weightlessness
- o To characterize the kinetic features of plant curvature induced by blue light stimulation in weightlessness
- o To determine the gravity threshold exposure time for a plant's gravity-sensing mechanism
- o To characterize the relationship between light dose and a plant's phototropic response in weightlessness
- o To test the validity of the reciprocity rule (constancy of the product of transversely applied G force and duration of application corresponding to a standardized response) without the complication of normal gravity



The squirrel monkey (Saimiri sciureus) experiment of Fuller (039) should provide a definitive answer to the basic questions concerning the effect of space flight on the circadian rhythms of the primate and on the corresponding regulation of body temperature. In this experiment, skin temperature (at five sites), colonic temperature, ambient temperature, feeding activity, drinking activity, and heart rate on four squirrel monkeys are all monitored continuously and sampled automatically by a switching device. In addition to being used in this experiment, these monkeys are used as subjects for the renal-endocrine experiment of Moore-Ede (223). Each of the animals will be exposed to the same 12-hour light/12-hour dark cycle during the flight (as well as both before and after the flight). This experiment specifically addresses the control of thermoregulation, the 24-hour entrainment of biorhythms, and the possible decoupling of the various components of the circadian timekeeping system, all during space flight. This is accomplished through the collection of a time-sequenced set of measurements which characterize the rhythmic patterns in the circadian timekeeping system (including temperature), and which indicate both the internal synchrony among the key variables and the external synchrony with the fixed 24-hour environmental time cue (light/dark cycles are the most potent synchronizers of primate circadian rhythms).

The frog (Rana pipiens) experiment of Tremor (256) addresses a long-debated issue in developmental biology related to the effect of gravity on the symmetry of developing amphibian embryos. This is a basic biological question which can only be answered by space flight, and the design of this experiment should yield unequivocal results. Both male and female frogs will be flown in space. Sperm solutions will be prepared in flight, and female frogs will be induced to ovulate by injections of pituitary extract. Fertilization tests and development tests will be conducted under both zero-g and one-g conditions (using a centrifuge). Embryos will be fixed 2.5, 24, and 58 hours after fertilization, and additional live embryos will be returned to Earth. After the flight, the live embryos will be allowed to develop further so that a study of later stages of development and of the effects that weightlessness during fertilization and early development has on subsequent inbred generations can be carried out. Of particular interest will be the development of the gravity-sensitive components of the inner ear, such as the otolith, in the absence of gravity. Measurements made on the developing eggs will involve both gross and microscopic (light and electromagnetic) examinations, as well as appropriate histological and cytological techniques of tissue staining and sectioning.

The plant experiments of Brown (236) and Heathcote (054) are concerned with the two most fundamental of the tropisms, geotropism and phototropism, and they share the same equipment. Thus, these experiments are complementary and synergistic in both their scientific yield and their operational requirements. Each experiment involves subjecting young plants grown in a one-g field (on a centrifuge) to a stress, and then recording the bending response of the shoots with a time lapse infrared video camera. Brown (236) uses oat (Avena sativa) seedlings and a transversely applied gravitational force as the stress, while Heathcote (054) uses wheat (Triticum aestivum) seedlings and a transversely applied pulse of blue light as the stress. In each case, different combinations of stimulus intensity and stimulus duration will be scheduled on plants at various stages of their development. The plants will be fixed in space and returned for postflight

morphological examination. Analysis of the time lapse video images will involve the determination of the kinetic bending response of the plants using a computer graphics technique. Thus, these two fundamental plant experiments should yield a characterization of both the gravitropic and phototropic response in weightlessness. In addition, analysis of the dose-response patterns should allow for the determination of threshold exposure times (particularly for the gravitropic response), and for the testing of the Reciprocity Rule over an extended range of G values (this rule states that the product of the transversely applied G force and the duration of application corresponding to a standardized response,  $G \times T$ , is constant over a wide range of G and T values). Regardless of the outcome of these experiments, the experimental results should answer fundamental questions concerned with the most basic responses of plants in weightlessness. Thus, these experiments are essential elements in any basic investigation regarding the use of plants in weightlessness.

## 1.5 PAYLOAD CHARACTERISTICS AND MISSION OBJECTIVES

The 25 experiments that comprise the current SL-4 payload, led by an international team of established investigators, have been woven into a tightly knit operational and scientific unit. Each experiment addresses a specific problem in one of many species and disciplines, ranging from the development of space-fertilized frog embryos to the examination of space motion sickness in humans. However, the underlying theme of all these experiments is the study of life in a weightless environment and, particularly, the biomedical problems encountered by man as he attempts to take full advantage of the opportunities to work in space. The mission payload now constitutes an integrated set of biological experiments which will provide us with a more accurate description of many of the acute and short term responses that allow man to adapt to weightlessness. This section of the mission overview discusses the general issues that were addressed during payload synthesis, describes the various integrative aspects of the payload, and sets forth the specific mission objectives that characterize the first dedicated life sciences mission. The following definitions have been used in this section to describe acute, short-term, and long-term periods. Acute refers to the first 3 days following launch. Short-term refers to the entire period of the Spacelab mission (i.e., one week). Long-term refers to events occurring in the period beyond one week of space flight.

### 1.5.1 Payload Synthesis

The guidelines for payload selection insured that the candidate experiments would lend themselves to combination and integration with each other, both scientifically and operationally. Therefore, payload synthesis was approached simultaneously and iteratively from two sides: science integration and operational integration. The basis of the science integration, which was discussed in detail earlier in section 1.3, is rooted in the fact that the processes which permit a complex organism such as man to adapt to a gravity-free environment are themselves complex and involve many organ systems and many interrelated pathways. Therefore, the study of zero-g adaptation requires a systematic integration of measurements across each physiological system. Consistent with this concept, the goals of science integration were to develop an interdisciplinary payload that would address the most critical areas in space physiology, to allow the major scientific

objectives of all final candidate principal investigators to be implemented, and to maximize the scientific yield of the mission as a whole. On the other hand, operational integration was concerned with insuring that finite mission resources were not exceeded and with optimizing the utilization of available resources. The actual integration process was a difficult one given the large number of experiments, their wide scope, and the varied mission constraints. Some of the broad guidelines which were developed to help achieve these sometimes conflicting goals included: a. insuring, where possible, that the scientific objectives of one investigation complemented and did not interfere with the aims of other investigations; b. facilitating the shared use of experimental measurements by more than a single investigator; c. limiting the scope of the science requirements so that resource boundaries were not exceeded; d. combining experiments to eliminate overlap and redundancy of experimental procedures; and e. promoting a more efficient utilization of both human and animal subjects.

### Science Integration

The most important thrust of the science integration effort was concerned with the idea of minimizing the weaknesses and developing the complementary aspects of each experiment. Therefore, complementary measurements within each discipline and across some disciplines are found that support and strengthen each experiment, while most duplicative and interfering measurements have been either combined or eliminated. However, complementary experiments between human and animal species must include redundant measurements so that appropriate animal validation data will be collected. Since it is true that each of the 25 experiments which make up this payload was originally proposed without knowledge of the other selected experiments, a crucial part of the payload definition process during the last several months, and one that will continue during the coming year, involves assisting the principal investigators in becoming familiar with the entire set of payload experiments and encouraging them to request data from other experiments as part of their own science requirements. This process has developed into a formal data sharing plan (see sections 5.0 and 6.0). In addition, the investigators were asked to identify and suggest reasonable modifications to their experiments in areas that would provide additional complementation and synergism to the mission as a whole. In this way, it was possible to create and support new science objectives without a large expenditure of resources by taking advantage of the scope of existing experimentation. Some examples of the results obtained from this effort are cited below. This entire iterative process of scientific integration, complementation, and synergism between experiments and across disciplines has created what has been referred to several times in this document as an optimum scientific yield; that is, an expected return from the mission that is greater than that which could be obtained from the sum of all experiments performed individually.

At this point, it is worthwhile to explore some of the detailed aspects of the interactions between experiments. This should not only give an appreciation of the high level of integration that was achieved, but should also provide insight into the manner in which the results from widely different kinds of experiments can be synthesized. Several different types of interactions are possible when various scientific disciplines and several kinds of animal species exist. The more meaningful ones include intradiscipline, interdiscipline, and interspecies studies.

Numerous examples of intradiscipline studies are possible on this mission because experiments were selected originally on their ability to contribute to a single intraspecies discipline. The cardiovascular/cardio-pulmonary area is the discipline of the highest scientific priority on the mission and also contains the largest number of experiments. The two most comprehensive human experiments within that discipline are highly complementary, the assessment of pulmonary function (West) and the evaluation of cardiovascular function (Blomqvist). This discipline also includes two different measures of human autonomic function (Blomqvist, Eckberg) and cardiac output (West, Farhi). The inflight human experiments in the vestibular area are represented by a group of synergistic experiments under a single lead investigator (Young). Other intraspecies disciplines that have multiple experiments include animal and plant studies. In each of these areas, there are examples of overlapping and complementary goals, so much so, that within each discipline there is almost complete animal and equipment sharing. These include rodent studies in the cardiovascular (Hutchins, Popovic), hematological (Dunn, Johnson), and muscle (Baldwin, Ellis, Hoh) disciplines, plant (Brown, Heathcote) studies, as well as the shared primate studies (Moore-Ede, Fuller).

The experiments devoted to human physiology provide a good example of the interdisciplinary (and intraspecies) studies being conducted on this mission. This effort is a broad-based, highly synergistic study comprised of at least one experiment in each of seven disciplines. The interaction between major subsystems is suggested in Figure 1.4. This simplified diagram attempts to illustrate the natural couplings between those systems dependent on whether the primary effect of weightlessness is on the fluid or on non-fluid tissues. Thus, in order to describe and truly understand the processes that lead to central hypervolemia or the involvement of autonomic and hormonal controllers, measurements should be included that reflect the status of all systems that are known to interact. The tight coupling of cardiopulmonary and renal-endocrine systems, the bone and muscle areas, and the overlapping effects of vestibular disturbances are suggested in this figure. While each experiment is complete in its own right, all of the investigators, cognizant of these interactions, are requesting data from other disciplines to support their objectives.

A number of common interdisciplinary objectives exist on this mission that cross over species boundaries. For example, the immediate responses to space flight are the concern of the renal-endocrine (Leach, Moore-Ede), cardiovascular (Blomqvist, Eckberg, Farhi, Hutchins, Popovic) and vestibular (Young, Cowings) groups. The role of blood volume reduction in the adaptive processes is being addressed by the hematological discipline (Dunn, Johnson), in addition to all of the above groups. Three investigators will collect data to analyze and characterize circadian rhythms of temperature (Fuller) and urinary constituents (Leach, Moore-Ede). These objectives require parallel measurements in the human, monkey, and rat.

From one point of view, a large portion of the mission payload can be thought of as two intraspecies studies, one using human subjects (11 experiments) and the other using the rat (9 experiments). All of the principal investigators who originally proposed rodent studies have agreed to use a common species of rat. This will facilitate interdisciplinary data analysis since it avoids the problem of species variability. In the same way, by using the identical crewmember subjects for all measurements, the

Figure 1.4

# INTERACTIONS BETWEEN MAJOR PHYSIOLOGICAL SYSTEMS DURING THE ADAPTATION TO WEIGHTLESSNESS

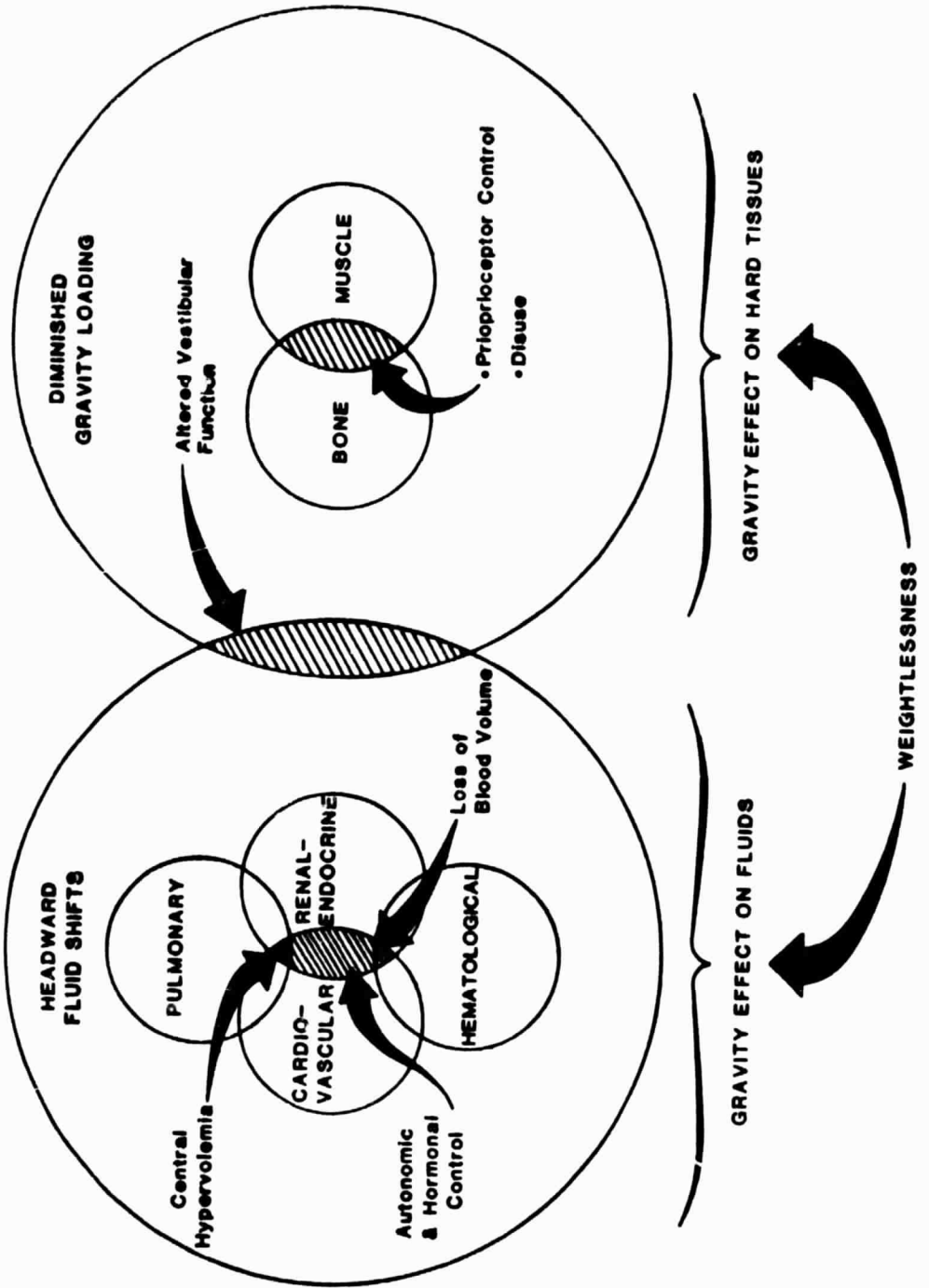

investigators of the human studies will be permitted to draw stronger conclusions regarding relationships between different interdisciplinary changes that are observed than they would if each discipline used a different subject group. Using identical subjects eliminates the variability between different population groups.

Of the various levels of scientific integration possible on this mission, perhaps the most useful (and the most complex) are the animal validation studies. An example of an interspecies animal model validation problem for SL-4 is shown in Figure 1.5. The purpose of the study in this case is to qualify both the rat and monkey as suitable animal models for the human response in the areas of acute fluid shifts and cardiovascular deconditioning. Including animals in the mission payload does not, per se, insure that proper validation studies will be accomplished. Animal and human studies must be tightly coupled. Each validation study must consider the particular animal species, the physiological system under examination, the specific group of measurements which accurately characterize the system and for which comparisons between species will be made, and finally, the appropriate experimental design to insure proper timing of measurements, proper controls, and statistical validity of results. When this is accomplished, many types of experimental integration are possible, as suggested in Figure 1.5, from the rat intraspecies investigations in the cardiovascular area to the cardiovascularfluid/electrolyte interdisciplinary studies of human adaptation, as well as the rat-human and monkey-human validation studies themselves.

### Operational Integration

While science integration resulted in a package of experiments that reflected investigator and mission science objectives, an optimal payload required that science requirements be translated into specific procedures that fully utilized but did not exceed available mission resources. This latter process, operational integration, consisted of detailed analyses of crew time, animal subject, measurement, sample, equipment, and procedural requirements. The scarcity of the crew time allotment in relation to the total requirements was one of the most difficult problems to face. Significant time savings were readily accomplished by identifying areas of commonality (that is, identical or similar procedures or measurements which were proposed by different investigators) and combining them in an appropriate manner. For example, this approach resulted in a plan to share blood collection and processing protocols between five different disciplines and a plan to share techniques for measuring human resting cardiovascular status among three intradiscipline experiments. This process not only resulted in a savings of crew time, but also permitted superior techniques to be chosen when alternative methods were proposed. Other logical combinations were achieved by a rodent animal sharing plan in which experiments within several disciplines were combined (cardiovascular, vestibular, hematology, calcium metabolism/bone, and muscle). The four squirrel monkeys were also shared by experiments in two disciplines (renal-endocrine and general biology). Equipment automation has been or will be developed in several areas to further reduce time requirements. The human cardiopulmonary experiment (West), the baroreflex sensitivity test (Eckberg), the immunological activity test (Cogoli), and the primate blood pressure, ECG, and urine sampling devices are all areas in which equipment and instrumentation have automated features. However, in addition to these approaches, it was necessary in several cases to ask the investigators to

Figure 1.5

# TYPICAL ANIMAL MODEL VALIDATION PROBLEM FOR LS-1

## Acute Fluid Shifts and Cardiovascular Deconditioning

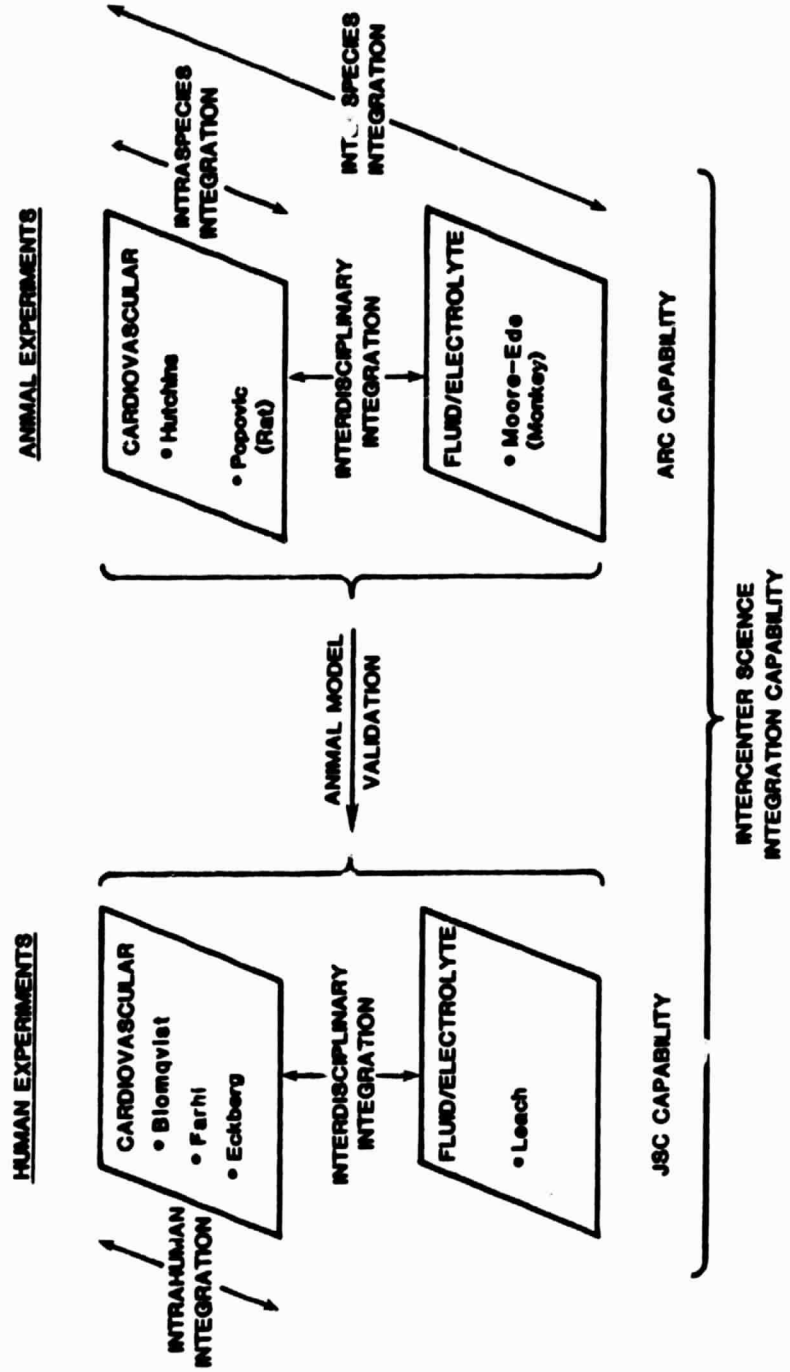

descope their experiments in some manner, either by reducing the number of subjects, decreasing the number of repetitions, or limiting their measurement requirements. Fortunately, all major science objectives were preserved among 24 of the selected experiments, and in several instances it was possible to enhance the experimental design by including additional measurement opportunities. The end result of this process, detailed project and mission session descriptions, is the subject of parts II and III of this document.

In addition to optimizing crew time, other aspects of the operational integration process included identifying areas which would permit animal and human subjects and equipment to be most effectively utilized. This resulted, in one instance, in an animal harvest plan by which a group of rodents that were exposed to weightlessness for the full length of the mission would be sacrificed on the last inflight day and their tissues stored for later distribution to several investigators in the animal sharing plan. It is also currently planned to implement an animal tissue bank whereby all the unused tissues of flight animals that are sacrificed, either inflight or postflight, would be made available to the general scientific community. Another problem concerns the human blood volume requirements (for the renal-endocrine, hematology, muscle, calcium metabolism/bone, and immunology disciplines), which are considered excessive by some investigators. This issue is currently being addressed by developing new micro-sampling techniques, examining ways to reduce the scope of blood analyses requirements, and performing a ground-support study to assess the maximum feasible blood draw allotment. Equipment is another resource that must be effectively shared in a remote space laboratory. Typical examples of equipment which is being shared (Life Science Laboratory Equipment, LSLE) include an analyzer for measuring expired gas composition being used by two investigators, the blood processing equipment being shared in part by five human and four animal discipline investigators, the plant rotors which will be used in two experiments concerned with plant development, a common set of biomedical monitoring instrumentation to be used by a number of cardiovascular investigators, and the body mass measuring devices for either human or animal subjects which is required by most of the investigators.

#### 1.5.2 Mission Objectives

The integration approach, discussed above, may be viewed as an optimization process by which the candidate experiments were combined in such a way as to take advantage of existing resources in order to achieve maximal alignment with the Announcement of Opportunity objectives. The specific objectives of the Announcement of Opportunity are:

- a. To investigate the physiological performance and biochemical changes which have been observed in humans who have flown in space.
- b. To identify and investigate significant biological phenomena related to exposure to the space environment.
- c. To test and demonstrate, under operational conditions, equipment and procedures which are needed by the LSFEP.

Payload synthesis has resulted in a group of specific mission objectives which are a reflection and an integration of the individual experiment objectives.



They describe the major themes of the mission and include the study of acute and short-term zero-g adaptation processes in man, validation of animal models, studies of basic gravitational biology, and development of flight qualified procedures and equipment. These objectives are consistent with the Announcement of Opportunity objectives, shown above, and the guidelines for experiment selection, mentioned in section 1.2. Each of the specific mission objectives for SL-4, and the manner in which they are satisfied, will be discussed in detail below.

#### OBJECTIVE #1. ACUTE RESPONSES TO ZERO-G

TO CONDUCT AN INTERDISCIPLINARY STUDY OF THE HUMAN AND ANIMAL RESPONSES WHICH OCCUR PROMPTLY UPON ACHIEVING WEIGHTLESSNESS, WITH THE MAJOR EMPHASIS ON CARDIOVASCULAR AND RENAL-ENDOCRINE RESPONSES TO ACUTE FLUID SHIFTS AND A SECONDARY EMPHASIS ON SPACE SICKNESS.

The most time-critical phase of the mission will be the first several days of flight (MD1 to MD3). It is within this time frame that the most dramatic physiological changes related to cephalad fluid shifts are believed to take place, that space sickness becomes manifest, and that other more slowly acting systems begin to exhibit the first signs of zero-g accommodation (see figure 1.3). The window for studying some of the earliest events is so narrow that experimental activities are scheduled just after lift-off and even prior to Spacelab activation.

A systematic series of measurements scheduled on the critical first day (see Table 1.18) will be devoted to testing a complex hypothesis that accounts for the rapid loss of body fluids. These measurements are derived primarily from eight experiments in the cardiovascular and renal-endocrine disciplines. While the most time-consuming portion of these tests will be conducted on human subjects, a number of significant and crucial measurements will also be performed on monkeys and rats. Direct measurement of central venous pressure and leg volume will help establish the degree and rapidity of fluid distribution from the periphery to the central vasculature. Changes in autonomic activity will be indicated by heart rate measurements and catecholamine levels. The influence on the heart itself will be studied by measuring cardiac output, echocardiographic dimensions, and ECG. The dynamic behavior of important renal regulating hormones will be observed by multiple blood samples; the role of renal hemodynamics will be determined directly by clearance studies; and estimations of body fluid losses will be assessed by blood hematocrit levels, monitoring of fluid intake, collection of each urine void, and body mass measurements. Direct measurement of the major body fluid compartment (total body water, extracellular fluids, and plasma volume) will be accomplished on mission days two and three. On the second day of flight, a comprehensive assessment of cardiopulmonary function, including submaximal exercise tests, will be conducted. The measurement of venous pressure, so important for understanding a variety of effects related to fluid redistribution, will begin before lift-off and be continued in the primate and rat for the duration of the mission. On the second and third day of the mission, measurements will be initiated to study the early effects of red cell mass loss, muscle atrophy, and bone demineralization.

TABLE 1.18  
INFLIGHT MEASUREMENTS OF ACUTE RESPONSES (MD1 ONLY)

MEASUREMENTS	HUMAN	RAT	MONKEY
<b>I. CARDIOVASCULAR RESPONSE</b>			
Venous Pressure (indwelling catheter)	X	X	X
Arterial Pressure	X	X	X
Heart Rate	X	X	X
ECG Waveform	X		X
Cardiac Output	X	X	
Cardiac Dimensions (Echocardiography)	X		
<b>II. RENAL/ENDOCRINE RESPONSE</b>			
Urine Excretion Rates (Volume and Electrolytes)	X		X
Renal Hemodynamics and Clearances	X		
Blood/Urine Electrolytes (Na <sup>+</sup> , K <sup>+</sup> , Ca <sup>+</sup> , PO <sub>4</sub> , Cl)	X		X
Blood/Urine Hormones (ADH, Renin-Angio, Aldosterone, Cortisol)	X		X
Hematocrit	X		X
<b>III. VESTIBULAR RESPONSE</b>			
Monitoring of Space Sickness	X		X
Self-Motion Perception and Ocular Counterrolling	X		
Vestibulo-Spinal Testing	X		
<b>IV. GENERAL</b>			
Leg Volume	X		
Body Mass	X		
Dietary Monitoring	X	X	X
Body Temperature			X

Plans for studying space sickness, an unpredictable event, will include preflight conditioning, symptom monitoring, evaluation of methods to predict inflight susceptibility to this malaise, and a test to reduce symptoms, should they occur, by temporarily reversing the effect of fluid shifts toward the head using lower body negative pressure (LBNP). Related vestibular disturbances will be examined by measuring the perception of self-motion and sensitivity of the otolith mediated vestibulo-spinal reflexes. Attempts will be made to correlate any incidences of space sickness with a broad range of circulatory, fluid, biochemical, and neurological changes which will be measured by a number of investigators during this acute phase of the mission.

## OBJECTIVE #2. ADAPTATION TO ZERO-G

TO CONDUCT AN INTERDISCIPLINARY SET OF STUDIES OF THE MOST SIGNIFICANT, KNOWN PROBLEMS OF SHORT-TERM ADAPTATION TO ZERO-G AND READAPTATION TO ONE-G WITH SPECIAL EMPHASIS ON THOSE ISSUES IN THE CARDIOPULMONARY, VESTIBULAR, RENAL-ENDOCRINE, HEMATOLOGICAL, MUSCLE, CALCIUM METABOLISM/BONE, AND IMMUNOLOGICAL AREAS WHICH CAN BE FRUITFULLY EXAMINED DURING THE COURSE OF A 7-DAY MISSION.

For the most part, these studies of short-term adaptation will extend observations that were begun during the first few days of the mission and, together with those measurements, will complement the findings from the Skylab program concerning long-term adaptation. With the exceptions of the central venous pressure measurement and of the motion sickness susceptibility testing with LBNP in humans, all of the tests conducted during the first 3 days will be repeated during the latter part of the mission. This will permit conclusions to be drawn regarding longitudinal effects during the first week of space flight. In addition, there will be a number of new studies in three broad areas: cardiovascular function, vestibular function and animal tissue collection. Cardiovascular stress tests will be conducted in humans using maximal exercise, LBNP, and drug infusions to test autonomic function, while observation of microcirculatory phenomena in the rat will complement systemic measurements of flow and pressures in that animal. Vestibular testing will be extended to determine changes in the vestibulo-ocular reflex and in awareness of body position and spatial localization. An animal harvest of tissues will be performed the last day of flight for extensive postflight analyses including muscle, vestibular, spleen, bone, and blood tissues. A summary of inflight tests and measurements in three major disciplinary areas (cardiovascular/ cardiopulmonary, renal-endocrine, and hematology) are presented in tables 1.19 through 1.23. When one considers the measurements in humans, monkeys, and rats together, the inflight studies in these three areas are easily the most comprehensive and, as suggested in Figure 1.4, are highly complementary.

Taken as a collection, these studies of short-term adaptation in humans and animals are impressive. Some areas of special concern are circulatory and cardiopulmonary adaptation during rest and mild exercise; the approach to new homeostatic levels for renal function, renal-regulating hormone secretion, body fluid volumes, and body fluid biochemistry; the adaptation of the vestibulo-neurological system and changes in otolith morphology; the search for a suppressive mechanism of erythropoiesis; the dynamic behavior of calcium metabolism; the pathways for muscle degradation

TABLE 1.19  
INFLIGHT CARDIOVASCULAR AND CARDIOPULMONARY MEASUREMENTS

MEASUREMENTS	HUMAN	RAT	MONKEY
<b>I. RESTING CARDIOVASCULAR STATUS</b>			
Venous Pressure	X*	X	X
Arterial Pressure	X	X	X
Heart Rate	X	X	X
ECG Waveform	X		X
Cardiac Output	X	X	
Cardiac Dimensions (Echocardiography)	X		
Forearm Blood Flow	X		
Forearm Venous Compliance	X		
Microcirculatory Observation		X	
<b>II. AUTONOMIC ADAPTATION</b>			
Adrenergic Activity (Drug Study)	X		
Baroreflex Sensitivity (Neck Suction)	X		
<b>III. FLUID VOLUME SHIFTS</b>			
Plasma Volume	X	X	
Hematocrit	X	X	X
Static Leg Volume	X		
Body Mass	X	X	
<b>IV. HORMONAL RESPONSE</b>			
Catecholamines	X		TBD
Angiotensin, Aldosterone, ADH	X	TBD	X
<b>V. STRESS RESPONSE</b>			
Exercise (Submaximal and Maximal)	X		
Orthostatic Tolerance (LBNP)	X	(X)	
<b>VI. PULMONARY FUNCTION</b>			
Pulmonary Blood Flow, Lung Volumes, Lung Tissue Volume, Lung	X		
Diffusing Capacity, Respiratory Gas Exchange, Blood Gases, Ventilatory Homogeneity			

\* Denotes Limited Study  
(X) Postflight Only

TABLE 1.20  
INFLIGHT RENAL-ENDOCRINE MEASUREMENTS

MEASUREMENTS	HUMAN	RAT	MONKEY
<b>I. BODY FLUIDS</b>			
Plasma Volume - Tracer Study ( $^{125}\text{I}$ )	X	X	
Extracellular Volume - Tracer Study ( $^{35}\text{S}$ )	X		
Total Body Water - Tracer Study (Ethanol)	X		
Hematocrit	X	X	X
<b>II. RENAL FUNCTION</b>			
Glomerular Filtration Rate - Tracer Study (PAH)	X		
Renal Plasma Flow - Tracer Study (Inutest)	X		
Aldosterone Secretory Study - Tracer Study ( $^3\text{H}$ )	X		
Urinary Volume (void-by-void)	X		X
Urine Solids (Daily)		X	
<b>III. BIOCHEMICAL ANALYSIS (see Table 1.22)</b>			
Blood Sample Analysis	X	X*	X
Urine Sample Analysis	X	X*	X
Fecal Sample Analysis			X
<b>IV. OTHER</b>			
Leg Volume	X		
Venous Pressure	X*	X	X
Arterial Pressure	X	X	X
Body Mass	X	X	
Food and Water Consumption	X	X	X

\* Denotes limited study

TABLE 1.21  
INFLIGHT HEMATOLOGY MEASUREMENTS

MEASUREMENTS	HUMAN	RAT	MONKEY
<b>I. GENERAL BLOOD ANALYSIS</b>			
(See Table 1.23)	X	X	X
<b>II. BLOOD VOLUME</b>			
Plasma Volume - Tracer Study ( <sup>125</sup> I)	X	X	
Red Cell Mass - Tracer Study ( <sup>51</sup> Cr)	(X)	(X)	
Hematocrit	X	X	X
<b>III. ERYTHROPOIESIS</b>			
RBC Production Rate - Tracer Study ( <sup>59</sup> Fe)	X	X	
Erythropoietin	X	X	
Erythropoietin Inhibitors	X	X	
Reticulocyte Index	X	X	X
Hemoglobin P <sub>50</sub>	X	X	X
Hemoglobin Synthesis Rate - Tracer Study ( <sup>15</sup> N)	X		
Bone Marrow and Spleen Mass, Cellularities and Differentials		X	
Bone Marrow and Spleen Cultures		(X)	
Hypoxic Response		(X)	
Blood Gas Tensions	X		
<b>IV. ERYTHROCYTE DESTRUCTION</b>			
Serum Chemistry (See Table 1.23)	X		X*
Red Cell Life Span - Tracer Study ( <sup>51</sup> Cr)	X	X	
<b>V. OTHER</b>			
Body Mass	X	X	
Food and Water Consumption	X	X	X

NOTE: ( ) Denotes preflight and postflight measurement only

\* Denotes limited study 1-66

TABLE 1.22  
 BLOOD AND EXCRETA BIOCHEMICAL ANALYSIS OF INFLIGHT SAMPLES  
 (RENAL-ENDOCRINE, MUSCLE, AND BONE DISCIPLINES)

CONSTITUENT	HUMAN		RAT			MONKEY		
	PLASMA	URINE	PLASMA	URINE	FECAL	PLASMA	URINE	FECAL
<b>ELECTROLYTES</b>								
Sodium	X	X	X			X	X	X
Potassium	X	X	X			X	X	X
Calcium	X	X	X	X	X	TBD	X	X
Phosphorus	X					TBD	X	X
Chloride		X				X	X	
Osmolarity	X	X				X	X	
<b>NITROGEN</b>								
Nitrogen								X
Creatinine	X	X						X
Proteins	X	X						
BUN			X					
Hemoglobin	X							
3-Methyl Histidine		X						
Hydroxy-Proline,-Lysine		X						
<b>HORMONES</b>								
ADH	X	X				X	X	
Renin-Angiotensin	X					X	X	
Aldosterone	X	X				X	X	
Natriuretic Activity		X						
Prostaglandins	X	X						
ACTH	X							
Cortisol	X	X				X	X	
Catecholamines	X	X						
Vitamin D	X							
Calcitonin	X							
Parathyroid Hormone	X							

TABLE 1.23  
BLOOD ANALYSIS OF INFLIGHT SAMPLES  
(HEMATOLOGY DISCIPLINE)

MEASUREMENTS	HUMAN	RAT	MONKEY
<b>I. HEMATOLOGICAL INDICES</b>			
RBC and WBC Counts	X	X	
Hemoglobin	X		
Hematocrit	X	X	X
Indices (MCC, MCH, MCHC)	X	X	
Reticulocyte Index	X	X	X
Reticulocyte Age Classification	X		
Oxygen-Hemoglobin P <sub>50</sub>	X	X	X
RBC Shape	X	X	X
Platelet Count	X	X	
WBC Differentials	X	X	
<b>II. SERUM CHEMISTRY</b>			
Total Protein	X		
Protein Distribution	X		
Haptoglobin	X		
Bilirubin	X		
Transferrin	X		
Ferritin	X		
Electrolytes (Na <sup>+</sup> , K <sup>+</sup> , Fe <sup>++</sup> , osmolality)	X		X
2,3-DPG	X		
ATP	X		
<b>III. ERYTHROPOIESIS AND IRON KINETICS</b>			
<sup>59</sup> Fe RBC Incorporation	X	X	
Erythropoietin	X	X	
Erythropoietin Inhibitors	X	X	



and changes in muscle tissue, and *in vitro* tests for alteration of immunological function. Routine blood and urine chemistries, blood counts, dietary intake, leg volume, and body mass measurements will be of general interest.

### OBJECTIVE #3. MODEL VALIDATION

TO DEVELOP VALID EXPERIMENTAL ZERO-G ANIMAL MODELS AND ONE-G ANALOGS OF WEIGHTLESSNESS WHICH CAN BE USED TO STUDY BIOMEDICAL PROBLEMS IN SPACE OR IN EARTH-BASED LABORATORIES.

It is expected that animals will have an increasing role on future missions especially when ethical or safety considerations preclude direct study in human subjects. Therefore, it is important that animals be qualified for flight studies as soon as possible. The degree to which accurate inferences regarding human physiology may be drawn from animal models is a function of the degree to which the animal model is validated. Each discipline generally has its own guidelines for proper validation. While no formal requirements have yet been established, a reasonable set of criteria for inflight animal validation are listed in Table 1.24. These criteria are listed in order of importance within each discipline (excluding vestibular) and are based on the major responses to weightlessness as they are known or believed to be. Table 1.24 also indicates the degree to which human and animal SL-4 studies overlap and satisfy these criteria. Additional information regarding commonality of inflight measurements can be found in Tables 1.18 through 1.23.

If successful comparisons between humans and animals can be made, it is expected that the rat and monkey will qualify as suitable animal models for human studies of weightlessness in several areas. In the case of the monkey, the original experiment (Moore-Ede) was designed to provide validation of the acute and short-term circulatory, renal, and endocrine adaptive responses. Monkey data will be compared with data from two human experiments (Leach, Blomqvist). The experimental objectives of several rat studies provide for appropriate validation of the circulatory system (Hutchins, Popovic), hematological system (Dunn, Johnson), and calcium metabolic system (Holton). The human data necessary for these validation studies will come from the human circulatory (Blomqvist, Farhi, West), hematological (Dunn), and calcium studies (Arnaud). Data from previous flights such as Skylab and the Russian Cosmos series will also be available for validation and confirmation.

During payload synthesis it was necessary to establish that the interspecies measurements were correctly performed and scheduled in order to produce proper validation studies. In addition, several areas were identified that would, with little extra effort, provide validations that were not previously considered. Thus, a limited primate validation study is scheduled in the hematological area. Other possibilities that are currently being explored include: a. measurements of plasma calcium regulatory hormones in rats; b. measurements of plasma electrolytes and renal-regulating hormones in rats; and c. circadian temperature measurements in humans to validate the corresponding primate experiment (Fuller). Validation experiments are considered weak in the muscle discipline because the primary emphasis of the rodent experiments is on muscle tissue analysis for which there is yet no human correlate. Even more difficult is the validation of animals in the vestibular area, where much of the human data involves subjective impressions.

TABLE 1.24

 CRITERIA FOR VALIDATION OF ANIMAL MODELS FOR STUDY  
 OF HUMAN RESPONSES IN WEIGHTLESSNESS

VALIDATION CRITERIA	HUMAN	RAT	MONKEY
<b>CARDIOVASCULAR DISCIPLINE</b>			
Demonstrate fluid shifts from lower to upper body	X		
Demonstrate enhanced circulatory response (flow, pressures) during acute phase	X	X	X
Demonstrate blood volume reduction	X	X	
Demonstrate orthostatic intolerance and/or diminished exercise capacity	X	X	
<b>RENAL-ENDOCRINE DISCIPLINE</b>			
Demonstrate fluid shifts from lower to upper body	X		
Demonstrate initial diuresis	X		X
Demonstrate loss of body fluids and salts	X		X
Demonstrate altered hormonal responses related to fluid and electrolyte regulation	X		X
<b>HEMATOLOGICAL DISCIPLINE</b>			
Demonstrate loss of red cell mass	X	X	
Demonstrate rapid loss of plasma volume and hemoconcentration	X	X	X
Demonstrate suppression of red cell production and/or enhanced destruction	X	X	
<b>MUSCLE DISCIPLINE</b>			
Demonstrate negative nitrogen and potassium balance	S		X
Demonstrate muscle atrophy by gross measurements such as muscle mass loss, loss of strength, fatigue	S	X	
Demonstrate suppression of protein synthesis and/or enhanced degradation	X		
Demonstrate alteration of muscle cell metabolism by biochemical, histological, and morphological studies		X	
<b>CALCIUM METABOLISM/BONE</b>			
Demonstrate negative calcium and phosphate balances	S	X	X
Demonstrate bone demineralization	S	X	
Demonstrate increased bone resorption	X	X	C
Demonstrate alterations of plasma constituents related to calcium regulation (electrolytes and hormones)	X		

KEY: X = to be performed on LS-1  
 S = previously performed on Skylab  
 C = performed on Cosmos

The data collected on humans during SL-4 represent not only information necessary for zero-g animal validation, but will also be used to assess the validity of several important ground-based analogs of weightlessness. These include the head-down tilt human model used for renal-endocrine (Leach) and circulatory studies (Blomqvist), a head-down tilt rat model used in circulatory (Popovic), hematological (Dunn) and bone (Holton) research, and a lower-body positive pressure primate model used for renal-endocrine and circulatory studies (Moore-Ede) as well as in the hematologyn area (Dunn). Finally, it should be mentioned that mathematical models of physiological function have been, and will be, used to aid in the analysis and interpretation of space-flight data. The interdisciplinary studies of SL-4 represent a rich source of valiation data for these computer models.

#### OBJECTIVE #4. GRAVITATIONAL BIOLOGY

TO INVESTIGATE SEVERAL SIGNIFICANT PROBLEMS OF BASIC GRAVITATIONAL BIOLOGY INCLUDING PLANT AND EMBRYO DEVELOPMENT AND CIRCADIAN TEMPERATURE RHYTHMS.

The importance of gravitational biology is recognized on this mission by the inclusion of four experiments which address issues of a fundamental nature and scientifically balance the payload. Two of these studies involve plant development with specific emphasis on gravitropism (Brown) and nutation and phototropism (Heathcote). These experiments, which share the same hardware and support equipment, will expose plants at various stages of development to graded gravitational and light fields and observe their influence on growth. A third study (Tremor) involves observations of the inflight fertilization and early development of frog eggs, a process known to be gravity sensitive, but never previously studied completely in zero-g. The fourth experiment (Fuller) is concerned with thermoregulation and the circadian rhythms of body temperature, both of which could be altered by weightlessness. Using the primate as a subject, a number of temperature probes will provide telemetered data throughout the mission which can be nicely correlated with other cardiovascular and renal-endocrine information obtained from a complementary experiment (Moore-Ede). These experiments all have automated features, therefore, are not crew-time intensive. It is also useful to point out that other experiments, although they address a known problem of manned space flight, also contain features of a more basic nature. These include the vestibulo-neurological experiments (Young), microcirculatory studies (Hutchins), circadian rhythms of urinary constituents (Leach, Moore-Ede), and morpholgical examination of muscle (Baldwin, Hoh, Ellis), bone (Holton), and otolith (Ross) tissue.

#### OBJECTIVE #5. DEVELOP PROCEDURES AND EQUIPMENT FOR SPACELAB

TO DEVELOP AND TEST, UNDER OPERATIONAL CONDITIONS, PROCEDURES AND EQUIPMENT WHICH ARE NEEDED TO CONDUCT BIOMEDICAL RESEARCH IN A SPACELAB ENVIRONMENT.

The SL-4 payload contains a number of unique aspects of investigation including new methodologies that have only recently been developed, invasive studies which have never been performed previously in space flight, and specialized equipment for studying animal and human physiology. Examples of

new physiological techniques that have been adapted for Spacelab include a non-invasive rebreathing method for measuring cardiac output, a baroreceptor sensitivity test using a neck suction device, an automated analyzer for administering a spectrum of cardiopulmonary function tests, a rotating dome for studying visual-vestibular-tactile interaction, an in vivo study of microcirculatory function in rats using a transparent skin flap chamber, and microsampling techniques for the assay of body fluids. Invasive studies include the use of radioactive and stable tracers (for measuring a variety of fluid compartments, renal clearances, calcium and protein fluxes, and red cell production), indwelling circulatory catheters and probes (for measuring circulatory pressures and cardiac output in humans and animals), animal sacrifice and dissection, and drug infusion studies for assessing autonomic function. Some of the specialized equipment that will be onboard includes a mass spectrometer, a two-dimensional echocardiograph, an LBNP device, automated urine collection devices for humans and primates, complete blood processing equipment, the research animal holding facility (RAHF), and the hardware for studying plant development. Most of this equipment is being developed by payload engineers in conjunction with the principal investigators. It is safe to say that many of these tests and a majority of this equipment, or their direct successors, will become general purpose research tools for other life science missions.

### Conclusion

Research conducted in a dedicated life sciences Spacelab will be unlike that ever performed before in the U.S. space program and quite different from that conducted in any traditional terrestrial laboratory. Concurrent operation of 25 experiments on humans, animals, and plants within a room-size remote laboratory; the use of surrogate investigators to perform the experiments and act also as subjects; and the detailed advanced planning, engineering, and preflight simulation studies are all unique aspects and constraints of this mission. However, the concept of a well-organized dedicated life sciences mission, even with its attendant difficulties, is justified on the basis of the great expense of flight research and the need for a totally integrated scientific approach. Also, this flight, along with other Spacelab missions, has widened the opportunities for an infusion of new ideas and participation of a new team of established investigators into the space research effort. It is likely that SL-4 will become the strongest biomedical mission yet flown.

Until now, the emphasis of mission planning has been devoted to definition and feasibility studies and experiment evaluation. Now that a payload has been identified and tentatively selected that fits within crew-time constraints and meets the research needs of the space life sciences, the more important and satisfying tasks of payload integration and science support studies can begin.

### 1.6 BIBLIOGRAPHY

This section presents a list of some of the major references pertinent to research being conducted on the SL-4 mission in space physiology and gravitational biology.

## GENERAL

Biomedical Results of Apollo, ed. by R. S. Johnston, L. F. Dietlein, and C. A. Berry, NASA SP-368, 1975.

Biomedical Results From Skylab, ed. by R. S. Johnston and L. F. Dietlein, NASA SP-377, 1977.

BIOSPEX: Biological Space Experiments: A Compendium of Life Sciences Experiments Carried on U.S. Spacecraft, NASA TM-58217, 1979.

Russian BIOSPEX: Biological Space Experiments: A Space Sciences Bibliography, NASA JSC-17072, 1981.

Future Directions for the Life Sciences in NASA, Report of the Life Sciences Advisory Committee of the NASA Advisory Council, ed. by G. D. Whedon, J. M. Hayes, H. C. Holloway, J. Spizizen, and S. P. Vinograd, NASA, November 1978.

Life Beyond the Earth's Environment, The Biology of Living Organisms in Space, ed. by N. S. Bricker and L. G. Fine, National Academy of Sciences, 1979.

## CARDIOVASCULAR/CARDIOPULMONARY DISCIPLINE

Hoffler, G. W. Cardiovascular studies of U.S. space crews: an overview and perspective. In Cardiovascular Flow Dynamics and Measurements, ed. by N.H.C. Hwang and N. A. Normann. Baltimore, University Park Press, 335-363, 1977.

Sandler, H. Cardiovascular effects of weightlessness. Prog. in Cardiology 5:227-270, 1976.

## VESTIBULAR DISCIPLINE

Benson, A. J. Possible mechanisms of motion and space sickness. Proc. European Symp. Life Sci. Res. In Space, ESA SP-130, 101-108, 1977.

Gualtieratti, T. Orbiting frog otolith experiment: final report. NASA CR-62084, 1979.

Homick, J.L. Space motion sickness. Acta Astronautica 6:1259-1272, 1979.

Parker, D. E. Labyrinth and cerebral-spinal fluid pressure changes following simulated zero gravity. Aviat. Space Environ. Med. 48:356-361, 1977.

Reason, J. T. and Brand, J. J. Motion Sickness. London, Academic Press, 1975.

Von Baumgarten, R. J., Bardrichi, G., Schillinger, G. L., Jr., Harth, U., and Thuemler, R. Vestibular function in the space environment. Acta Astronautica 2:49-58, 1974.

## RENAL/ENDOCRINE DISCIPLINE

Berry, C. A. Medical legacy of Apollo. Aero. Space Med. 45:1046-1057, 1974.

Leach, C. S. Review of endocrine results: Project Mercury, Gemini Program, and Apollo Program. Proc. of the 1970 Manned Space Center Endocrine Conference, NASA TMS-58086, 3-1 to 3-16, 1971, also in Leonard, J., Grounds, D. G. and Fitzjerrell, D., Skylab Medical Data Evaluation Program, General Electric Co., TIR 741-LSP-7020, 1977.

Leach, C. S. A review of the consequences of fluid and electrolyte shifts in weightlessness. Acta Astronautica 6:1123-1135, 1979.

## HEMATOLOGY DISCIPLINE

Fischer, C. L. and Kimzey, S. L. Hematology studies on Gemini and Apollo missions. Proc. of the 1970 Manned Space Center Endocrine Conference, NASA TMX-58086, 2-1 to 2-14, 1971.

Kimzey, S. L., Leonard, J. I. and Johnson, P.C. A mathematical and experimental simulation of the hematological response to weightlessness. Acta Astronautica 6:1289-1303, 1979.

Kimzey, S. L. The effect of extended space flight on hematologic and immunologic systems. J. Am. Med. Women's Assoc. 30:218-232, 1975.

## IMMUNOLOGY DISCIPLINE

The Apollo-Soyuz Test Project: Medical Report, ed. by A. E. Nicogossian, NASA SP-411, 1977.

Kimzey, S. L. The effect of extended space flight on hematologic and immunologic systems. J. Am. Med. Women's Assoc. 30:218-232, 1975.

Martin, R. R., Warr, G. A., Putman, M. J., Kentron, D. H., and Holleman, C. L. Polymorphonuclear leukocyte response (MA-032). In ASTP Summary Science Report, NASA, Vol. 1, 263-279, 1977.

Cogoli, A., Valluchi-Morf, M., Mueller, M., and Briegleb, W. Effect of hypogravity on human lymphocyte activation. Aviat. Space Environ. Med. 51:29-34, 1980.

## MUSCLE DISCIPLINE

Fedorov, I. V., Shurova, I. F. Content of protein and nucleic acids in the tissues of animals during hypokinesia. Kosm. Biolog. i Aviak. Med. 7:17-21, 1973.

Il'ina-Kakuyeva, Ye. I., Portugalov, V. V., and Krivenkova, N. P. Effects of space-flight factors on skeletal muscles of rats. Kosm. Biolog. i Aviak. Med. 1:20-25, 1977.

Kazarian, V. A., Rapoport, E. A., Goncharova, L. A., and Bulycheva, S. Ya. Effect of prolonged weightlessness on metabolism of proteins in red and white skeletal muscles of rats. Kosm. Biolog. i Aviak. Med. 6:19-23, 1977.

Leach, C. S., Rambaut, P. C., and DiFerrante, N. Amino aciduria in weightlessness. Acta Astronautica 6:1323-1333, 1979.

Rassolova, N. P., Potapov, A. N., Sapelkina, I. M., and Grebennikova, I. I. Effect of prolonged hypokinesia on some indices of energy metabolism in the skeletal muscles and in some internal organs. Kosm. Biolog. i Aviak. Med. 7:26-33, 1973.

#### CALCIUM METABOLISM/BONE DISCIPLINE

Cann, C. E., Adachi, R. R., and Holton E. M. Bone resorption and calcium absorption in rats during spaceflight. Physiologist 23:S83-S86, 1980.

Morey, E. R. and Baylink, D. J. Inhibition of bone formation during space flight. Science 201:1138-1141, 1978.

Rambaut, P. C. and Johnston, R. S. Prolonged weightlessness and calcium loss in man. Acta Astronautica 6:1113-1122, 1979.

#### GRAVITATIONAL BIOLOGY DISCIPLINE

Gravity and the Organism, ed. by S. A. Gordon and M. C. Cohen, Univ. Chicago Press, 1971.

Foundations of Space Biology and Medicine, ed. by M. Calvin and O. Gzenko, NASA (Washington), 1975.

Fuller, C. A., Sulzman, F. M., and Moore-Ede, M. C. Thermoregulation is impaired in an environment without circadian time cues. Science 199:794-796, 1978.

Hahn, P. M., Hoshizaki, T., and Adey, W. R. Circadian rhythm of the Macaca nemestrina monkey in Biosatellite III. Aerospace Med. 42:295-304, 1971.

Klein, H. P. U.S. Biological experiments in space. Acta Astronautica 8:927-938, 1981.

Krikorian, A. D. and Steward, F. C. Is gravity a morphological determinant at the cellular level? Life Sciences and Space Research 17:251-284, New York, Pergamon Press, 1979.

Osborne, J. Hormones and the growth of plants in response to gravity. Life Sciences and Space Research 14:37-45, 1976.

Siegel, S. M. Metabolism and energetics in hypogravity: degenerative effects in a higher plant. AIBS-NASA Symposium, Washington D.C., February 7-8, 1976.

Tremor, J. W., and Souza, K. A. The influence of clinostat rotation on the fertilized amphibian egg. Space Life Sciences 3:179-191, 1972.

Young, R. S. Gravity and embryonic development. Life Sciences and Space Research 14:69-75, 1976.



## APPENDIX A

### Investigators for Proposed Dedicated Spacelab Payload

This unofficial list of investigators is included in order to enhance communication among those concerned with the SL-4 mission.

1. Claude D. Arnaud, M.D. Principal Investigator: Experiment No. 305  
Veterans Administration Hospital  
4150 Clement Street  
San Francisco, CA 94121  
(415)752-6136/752-8857
2. Kenneth M. Baldwin, Ph.D. Principal Investigator: Experiment No. 127  
Department of Physiology  
and Biophysics  
California College of Medicine  
University of California at Irvine  
Irvine, CA 92717  
(714)833-7192
3. C. Gunnar Blomqvist, M.D. Principal Investigator: Experiment No. 294  
Department of Medicine, Rm. H-8122  
University of Texas Health  
Sciences Center  
5323 Harry Hines Boulevard  
Dallas, TX 75235  
(214)688-3425
4. Allan H. Brown, Ph.D. Principal Investigator: Experiment No. 236  
Department of Biology/G5 Co-Investigator: Experiment Nos. 054, 240  
University City Science Center  
University of Pennsylvania  
Philadelphia, PA 19104  
(215)243-7807
5. Christopher E. Cann, Ph.D. Co-Investigator: Experiment Nos. 194, 305  
Department of Radiology  
University of California  
at San Francisco  
San Francisco, CA 94143  
(415)965-5885
6. Mr. David K. Chapman Co-Investigator: Experiment No. 236  
Department of Biology/G5  
University City Science Center  
University of Pennsylvania  
Philadelphia, PA 19104  
(215)243-4908

Augusto Cogoli, Ph.D.  
Laboratorium fur Biochemie  
Swiss Federal  
Institute of Technology  
ETH-Zentrum  
CH-8092 ZURICH  
Switzerland  
41-01/326211 Ext. 3135

Principal Investigator: Experiment No. 240

Patricia S. Cowings, Ph.D.  
Mail Stop 239-17  
NASA Ames Research Center  
Moffett Field, CA 94035  
(415)965-5724, FTS 448-5724

Principal Investigator: Experiment No. 195

B. Sue Criswell, Ph.D.  
University of Arizona  
Health Sciences Center  
1435 N. Fremont  
Tucson, AZ 85719  
(602)626-4084

Co-Investigator: Experiment No. 240

Christopher D. R. Dunn, Ph.D.  
Department of Experimental Biology  
Baylor College of Medicine  
1200 Moursund Avenue  
Houston, TX 77030  
(713)790-4650

Principal Investigator: Experiment Nos. 012, 261

Dwain L. Eckberg, M.D.  
Medicine College of Virginia  
Virginia Commonwealth University  
MCV Station  
Richmond, VA 23298  
(804)231-9011, Ext. 538, 453, 455

Principal Investigator: Experiment No. 022

Stanley Ellis, Ph.D.  
Mail Stop 239-17  
NASA Ames Research Center  
Moffett Field, CA 94035  
(415)965-5757, FTS 448-5757

Principal Investigator: Experiment No. 303

Leon E. Farhi, M.D.  
Department of Physiology  
State University of New York  
at Buffalo  
Buffalo, NY 14214  
(716)831-2739

Principal Investigator: Experiment No. 066

Charles A. Fuller, Ph.D.  
Division of Biomedical Sciences  
University of California  
at Riverside  
Riverside, CA 92521  
(714)787-3094

Principal Investigator: Experiment No. 039  
Co-Investigator: Experiment No. 223

15. F. Andrew Gaffney, M.D.  
University of Texas Health  
Science Center  
Southwestern Medical School  
5323 Harry Hines Boulevard  
Dallas, TX 75235  
(214)688-2092  
Co-Investigator: Experiment No. 294
16. Harold Guy, Ph.D.  
Department of Medicine  
University of California  
at San Diego  
La Jolla, CA 92093  
Co-Investigator: Experiment No. 198
17. David G. Heathcote, Ph.D.  
Department of Plant Sciences  
University College of South Wales  
P.O. Box 78  
Cardiff CF1 1XL United Kingdom  
(0222)44211  
Principal Investigator: Experiment No. 054
18. Ernest R. Hilgard, D.Sc.  
Stanford Univeristy  
Stanford, CA 94305  
(415)497-4441  
Co-Investigator: Experiment No. 195
19. Joseph Foon Yoong Hoh, Ph.D.  
Department of Physiology  
University of Sydney  
Sydney NSW 2006  
Australia  
02(Area Code)692-3370  
Principal Investigator: Experiment No. 247
20. Emily M. Holton, Ph.D.  
Mail Stop 239-14  
NASA Ames Research Center  
Moffett Field, CA 94035  
(415)965-5471, FTS 448-5471  
Principal Investigator: Experiment No. 194  
Co-Investigator: Experiment No. 305
21. Phillip M. Hutchins, Ph.D.  
Department of Physiology  
and Pharmacology  
Bowman Gray School of Medicine  
Winston-Salem, NC 27103  
(919)748-4344  
Principal Investigator: Experiment No. 166
22. Philip C. Johnson, M.D.  
Mail Code SD3  
NASA Johnson Space Center  
Houston, TX 77058  
(713)483-5457, FTS 525-5457  
Principal Investigator: Experiment No. 141  
Co-Investigator: Experiment Nos. 192, 261

23. Robert L. Johnson, M.D.  
Department of Internal Medicine  
University of Texas Health  
Science Center  
Southwestern Medical School  
5323 Harry Hines Boulevard  
Dallas, TX 75235  
Co-Investigator: Experiment No. 294
24. Anders Johnsson, Ph.D.  
Institute of Physics,  
Biophysics Group  
University of Trondheim  
N-7000 Trondheim  
Norway  
075 96170  
Co-Investigator: Experiment No. 236
25. Geoffrey Melvill Jones, M.D.  
McGill University  
3655 Drummond Street  
Montreal, Quebec  
Canada H3G 1Y6  
(514)392-4217  
Co-Investigator: Experiment No. 072
26. Joe Kamiya, Ph.D.  
Langley Porter Neuropsychiatric  
Institute  
University of California School  
of Medicine  
San Francisco, CA 94122  
(415)713-8046  
Co-Investigator: Experiment No. 195
27. Robert D. Lange, M.D.  
University of Tennessee  
Memorial Research Center  
Center for the Health  
Sciences/Knoxville  
1924 Alcoa Highway  
Knoxville, TN 37920  
(615)971-9235  
Co-Investigator: Experiment No. 012
28. Carolyn S. Leach, Ph.D.  
Mail Code SD4  
NASA Johnson Space Center  
Houston, TX 77058  
(713)483-4086, FTS 525-4086  
Principal Investigator: Experiment No. 192  
Co-Investigator: Experiment Nos. 223, 261
29. Joel I. Leonard, Ph.D.  
MATSCO  
1050 Bay Area Blvd.  
Houston, TX 77058  
(713) 488-9005  
Co-Investigator: Experiment No. 192

30. Samuel Lewis  
Department of Nuclear Medicine  
Parkland Memorial Hospital  
5201 Harry Hines Boulevard  
Dallas, TX 75235  
Co-Investigator: Experiment No. 294
31. David B. Michels, Ph.D.  
Scientific and Educational  
Consultant  
10828 Amigo Avenue  
Northridge, CA 91326  
(213)702-4336  
Co-Investigator: Experiment No. 198
32. Neal E. Miller, D.Sc.  
Rockefeller University of New York  
1230 York Ave.  
New York, NY 10021  
(212)360-1584  
Co-Investigator: Experiment No. 195
33. Jere H. Mitchell, M.D.  
University of Texas Health  
Science Center  
Southwestern Medical School  
5323 Harry Hines Boulevard  
Dallas, TX 75235  
Co-Investigator: Experiment No. 294
34. Kenneth E. Money Ph.D.  
D.C.I.E.M.  
1133 Sheppard Ave. W.  
P.O. Box 2000  
Downsview, Ontario  
Canada M3M 3D9  
(416)633-4240  
Co-Investigator: Experiment No. 072
35. Martin C. Moore-Ede, M.D., Ph.D.  
Department of Physiology  
Harvard Medical School  
25 Shattuck Street  
Boston, MA 02115  
(617)732-1826  
Principal Investigator: Experiment No. 223  
Co-Investigator: Experiment No. 039
36. Mr. Richard A. Morin  
Department of Physiology  
State University of New York  
at Buffalo  
Buffalo, NY 14214  
(716)831-4709  
Co-Investigator: Experiment No. 066
37. Gary E. Musgrave, Ph.D.  
Medical College of Virginia  
Virginia Commonwealth University  
MCV Station  
Richmond, VA 23298  
(804)231-9011, x.538  
Co-Investigator: Experiment No. 022

38. George W. Nace, Ph.D.  
Department of Zoology  
University of Michigan  
Ann Arbor, MI 48104  
(313)764-1471  
**Co-Investigator: Experiment No. 256**
39. A. J. Olszowka, M.D.  
Department of Physiology  
State University of New York  
at Buffalo  
Buffalo, NY 14214  
(716)831-5464  
**Co-Investigator: Experiment No. 066**
40. Charles M. Oman, Ph.D.  
Room 37-211  
Massachusetts Institute of  
Technology  
77 Massachusetts Avenue  
Cambridge, MA 02139  
(617)253-7805  
**Co-Investigator: Experiment No. 072**
41. Pava Popovic, Ph.D.  
Department of Physiology  
Emory University Medical School  
Atlanta, GA 30322  
(404)329-7400  
**Co-Investigator: Experiment No. 248**
42. Vojin P. Popovic, D.Sc.  
Department of Physiology  
Emory University Medical School  
Atlanta, GA 30322  
(404)329-7413  
**Principal Investigator: Experiment No. 248**
43. Paul C. Rambaut, Sc.D.  
Mail Code SBR-3  
NASA Headquarters  
Washington, DC 20546  
(202)755-3723, FTS 755-3723  
**Co-Investigator: Experiment No. 192**
44. Dan A. Riley, Ph.D.  
Medical College of Wisconsin  
Department of Anatomy  
8701 Watertown Plank Road  
P.O. Box 26509  
Milwaukee, WI 53226  
(414)257-8468  
**Co-Investigator: Experiment No. 303**
45. W. Eugene Roberts, D.D.S., Ph.D.  
University of the Pacific Dental  
School  
Orthodontics Department, Rm. 130  
2155 Webster Street  
San Francisco, CA 94115  
(415)929-6500  
**Co-Investigator: Experiments No. 194**

46. Muriel D. Ross, Ph.D.  
 Department of Anatomy  
 University of Michigan  
 Medical School  
 Ann Arbor, MI 48109  
 (313)763-2539, FTS 963-2539  
 Principal Investigator: Experiment No. 238  
 Co-Investigator: Experiment No. 256
47. Loring B. Rowell, Ph.D.  
 Department of Physiology  
 and Biophysics  
 University of Washington  
 School of Medicine  
 Seattle, WA 98195  
 Co-Investigator: Experiment No. 294
48. Charles F. Sawin, Ph.D.  
 Perkin-Elmer Corporation  
 2771 N. Carey  
 Pomona, CA 91769  
 (714)593-3581, Ext. 348  
 Co-Investigator: Experiment No. 198
49. Joseph Sharp, Ph.D.  
 Mail Stop 200-7  
 NASA Ames Research Center  
 Moffett Field, CA 94035  
 (415)965-5100, FTS 448-5100  
 Co-Investigator: Experiment No. 195
50. Thomas L. Smith, Ph.D.  
 Department of Physiology  
 and Biophysics  
 University of Mississippi  
 School of Medicine  
 Jackson, MS 39216  
 (601)987-4796  
 Co-Investigator: Experiment No. 166
51. Mr. Kenneth A. Souza  
 Mail Stop 236-5  
 NASA Ames Research Center  
 Moffett Field, CA 94035  
 (415)965-5735, FTS 448-5735  
 Co-Investigator: Experiment No. 256
52. Thomas P. Stein, Ph.D.  
 Surgical Research Labora-  
 tories  
 Graduate Hospital  
 19th and Lombard Streets  
 Philadelphia, PA 19146  
 (215)893-2611, 243-7111  
 Principal Investigator: Experiment No. 120
53. Wadi N. Suki, M.D.  
 Baylor College of Medicine  
 The Methodist Hospital  
 Houston, TX 77030  
 (713)790-3275  
 Co-Investigator: Experiment No. 192

54. Frank M. Sulzman, Ph.D. Co-Investigator: Experiment Nos. 039, 223  
Harvard Medical School  
25 Shattuck Street  
Boston, MA 02115  
(617)732-1826
55. Trieve Tanner, Ph.D. Co-Investigator: Experiment No. 195  
Mail Stop 239-2  
NASA Ames Research Center  
Moffett Field, CA 94035  
(415)965-5185, FTS 448-5185
56. Mr. William B. Toscano Co-Investigator: Experiment No. 195  
Langley Porter Neuropsychiatric  
Institute  
University of California  
School of Medicine  
San Francisco, CA 94122  
(415)965-5724
57. John W. Tremor, Ph.D. Principal Investigator: Experiment No. 256  
Mail Stop 236-5  
NASA Ames Research Center  
Moffett Field, CA 94035  
(415)965-5731, FTS 448-5731
58. Peter D. Wagner, M.D. Co-Investigator: Experiment No. 198  
Department of Medicine  
University of California  
at San Diego  
La Jolla, CA 92093  
(714)452-4190
59. Douglas G. D. Watt, Ph.D. Co-Investigator: Experiment No. 072  
McGill University  
3655 Drummond Street  
Montreal, Quebec  
Canada H3G 1Y6  
(514)392-4216
60. John B. West, M.D., Ph.D. Principal Investigator: Experiment No. 198  
Department of Medicine  
University of California  
at San Diego  
La Jolla, CA 92093  
(714)452-2230
61. Thomas Wronski, Ph.D. Co-Investigator: Experiment No. 194  
University of California at  
San Francisco  
Medical Center, Rm. M997  
Third Avenue and Parnassus  
San Francisco, CA 94143  
(415)666-2550



62. Laurence R. Young, Sc.D.  
Room 37-207  
Massachusetts Institute  
of Technology  
77 Massachusetts Ave.  
Cambridge, MA 02139  
(617)253-7759

Principal Investigator: Experiment No. 072