

NASA Technical Memorandum 86728

NASA-TM-86728

19850024811

Application of Frequency Domain Handling Qualities Criteria to the Longitudinal Landing Task

Shahan K. Sarrafian and Bruce G. Powers

LIBRARY COPY

SEP 6 1985

L. J. KELLY RESEARCH CENTER
LIBRARY, NASA
HAMPTON, VIRGINIA

August 1985

National Aeronautics and
Space Administration



3 1176 00187 9379

Application of Frequency Domain Handling Qualities Criteria to the Longitudinal Landing Task

Shahan K. Sarrafian and Bruce G. Powers
Ames Research Center, Dryden Flight Research Facility, Edwards, California

1985

NASA
National Aeronautics and
Space Administration
Ames Research Center
Dryden Flight Research Facility
Edwards, California 93523

1985-33124 #

APPLICATION OF FREQUENCY DOMAIN HANDLING QUALITIES CRITERIA TO THE
LONGITUDINAL LANDING TASK

Shahan K Sarrafian* and Bruce G Powers†
NASA Ames Research Center, Dryden Flight Research Facility
Edwards, California

Abstract

In recent years, advances in flight controls technology have resulted in the use of elaborate fly-by-wire systems that provide stability augmentation for both transport and high-performance aircraft with static instability. Pitch-rate command/attitude-hold systems are typically employed for this purpose and are used on such modern aircraft as the F-16, X-29, and Shuttle. In the flared landing task, however, these systems have exhibited floating and ballooning tendencies which result in handling qualities results that are inconsistent with classical predictive criteria.

Under NASA sponsorship, an in-flight simulation of the longitudinal handling qualities of several configurations for the approach and landing task was performed on the USAF/AFWAL Total In-Flight Simulator by the Calspan Corporation. The basic configuration was a generic transport airplane with static instability. The control laws included proportional plus integral gain loops to produce pitch-rate command/attitude-hold systems which were evaluated with and without prefilters. Conventional response characteristics were obtained by using pitch-rate and angle-of-attack feedback loops. The evaluation task was a conventional visual approach to a flared touchdown at a designated spot on the runway with a lateral offset.

The general conclusions were that the existing criteria are based on pitch-attitude response and that these characteristics do not adequately discriminate between the good and bad configurations of this study. This paper describes the work that has been done to further develop frequency-based criteria in an effort to provide better correlation with the observed data.

Nomenclature

F_{es} = longitudinal stick force, lb
 h_p = altitude at pilot station, ft
 h_{pc} = altitude at pilot station command, ft
 \dot{h}_p = altitude rate at pilot station, ft/sec

K_α = angle-of-attack feedback gain, deg/deg
 K_C = command gain
 K_I = integral gain
 K_L = proportional gain
 K_P = pilot gain
 K_q = pitch rate feedback gain, deg/sec/deg/sec
PIO = pilot-induced oscillation
 q = pitch rate, rad/sec
 s = Laplace operator
TIFS = Total In-Flight Simulator
 T_Z = prefilter lead time constant, sec
 T_F = prefilter lag time constant, sec
 T_L = Neal-Smith pilot model lead time constant, sec
 T_ℓ = Neal-Smith pilot model lag time constant, sec
 T_{wo} = washout filter time constant, sec
 α = angle of attack, deg
 λ_2' = real root due to augmentation system
 θ = pitch attitude, deg
 θ_c = pitch attitude command, deg
 ω_{nsp} = short period natural frequency, rad/sec
 ζ_{sp} = short period damping ratio
 $e^{-\tau s}$ = pure time delay, sec
 ω_{BW} = bandwidth frequency, rad/sec
 $1/T_{\theta 2}$ = pitch rate numerator term due to lift curve slope, sec^{-1}

Introduction

In recent years, advances in flight controls technology have resulted in the use of elaborate fly-by-wire systems that provide stability augmentation for both transport and high-performance

*Aerospace Engineer. Member AIAA
†Senior Aerospace Engineer. Member AIAA

This paper is declared a work of the U S Government and therefore is in the public domain

aircraft with static instability. Pitch-rate command/attitude-hold systems are typically employed for this purpose and are used on such modern aircraft as the F-16, X-29, and Shuttle. In the flared landing task, however, these systems have exhibited floating and ballooning tendencies. Longitudinal PIO tendencies have also been observed on occasion when pilots attempt tight closed-loop control with such systems. The resulting aircraft characteristics yielded handling qualities results which have not been consistent with classical predictive criteria. Clearly, these longitudinal predictive criteria need to be refined for better correlation with handling qualities results obtained from the use of such stability augmentation systems.

Under NASA sponsorship, an in-flight simulation of the longitudinal handling qualities of several configurations for the approach and landing task was performed on the USAF/AFWAL Total In-Flight Simulator (TIFS) by the Calspan Corporation, Buffalo, NY. The experiment description and results are presented in Ref. 1. The basic configuration was a generic transport airplane with static instability. Seven aerodynamic configurations were obtained by varying the lift curve slope, static stability, and lift due to elevator characteristics. Eight variations of control laws were used with the seven aerodynamic models to produce 27 flight-control/airplane configurations for the study. The control laws included proportional plus integral gain loops to produce pitch-rate command/attitude-hold systems which were evaluated with and without prefilters. Conventional response characteristics were obtained by using pitch-rate and angle-of-attack feedback loops. The evaluation task was a conventional visual approach to a flared touchdown at a designated spot on the runway. A 300-ft lateral offset and a discrete vertical gust were used to increase pilot workload.

The general conclusions of the study presented in Ref. 1 were that the existing criteria are generally based on pitch-attitude response and that these characteristics do not adequately discriminate between the good and bad configurations of this study. A time-domain criterion was developed based on angle of attack and normal acceleration at the pilot station, and improved correlation was shown. A frequency-domain criterion based on sink rate at the pilot station was also shown to be a slight improvement over the pitch-attitude criteria. This paper describes the work that has been done to further develop frequency-based criteria in an effort to provide better correlation with the observed data.

Configuration Set Description

The configurations evaluated during the in-flight simulation used a flight-control system of a generic transport which is presented in block

diagram form in Fig. 1. A summary of the configurations in terms of the q/F_{es} transfer function is presented in Table 1. Other transfer functions for these configurations are presented in Ref. 1. The pilot ratings assigned to the configurations are based upon the Cooper-Harper rating scale (NASA TN D-5153). A brief description of each configuration set is presented below. These configuration sets are the primary database for the various frequency-domain criteria applications in this paper.

Set 1 Configuration

Set 1 consisted of three pitch-rate feedback configurations with proportional plus integral paths. The short period was set at $\omega_{nsp} = 2.8$ rad/sec and $\tau_{sp} = 0.8$. The pitch-rate numerator term $(1/T_{\theta 2})^p$ was set at 0.38, 0.72, and 1.0.

Set 2 Configurations

Set 2 contained two pitch-rate feedback configurations with proportional plus integral paths. The short period was set at $\omega_{nsp} = 1.8$ rad/sec and $\tau_{sp} = 0.6$. The pitch-rate numerator term $(1/T_{\theta 2})^p$ was set at 0.38 and 0.72.

Set 3 Configurations

Set 3 included two neutral-static-stability configurations obtained by removing the integrator in the forward path and modifying the aircraft model, which resulted in a first-order pitch-rate response. $1/T_{\theta 2}$ was set at 0.38 and 0.72.

Set 4 Configurations

Set 4 consisted of set 1 with the addition of a lead/lag prefilter designed to cancel the control system zero at K_I and the augmented real root λ_2' near $1/T_{\theta 2}$. Configuration 4-3-7-1 added a washout filter in series with the lead/lag prefilter. The washout filter canceled the integrator root of the augmented system at frequencies below 0.2 rad/sec.

Set 5 Configurations

Set 5 consisted of set 2 with the lead/lag prefilter.

Set 6 Configurations

Set 6 contained four pitch-rate feedback configurations with high proportional plus integrator gain in the forward path. The basic configuration had a $1/T_{\theta 2} = 0.38$. The other configurations consisted of basic plus washout, basic plus prefilter, and basic plus washout and prefilter.

Set 7 Configuration

Set 7 included one "conventional" configuration obtained by using angle of attack and pitch-rate feedback loops with one of the neutral-static stability aircraft models.

Set 8 Configurations

Set 8 consisted of five "Shuttle-like" configurations with a $1/T_{\theta 2} = 0.40$. Four of the models placed the pilot 10 ft behind the center of rotation. The fifth model was a canard configuration that placed the pilot 54 ft forward of the center of rotation. The first four models were also evaluated with the washout filter used in sets 4 and 6.

Pitch-Attitude Frequency-Domain Criterion

The Neal-Smith theory² is widely used to analyze the closed-loop pitch-attitude control of aircraft. This method assumed pitch-attitude control to be the primary task of the pilot. An overview of the Neal-Smith theory is presented below. This is intended as a review for those somewhat familiar with Neal-Smith theory. For a more thorough explanation of the Neal-Smith theory, see Ref. 2.

Technique Description

The Neal-Smith theory is based upon a single-loop closure performed on pitch attitude using a pilot model that employs a lead/lag filter with a gain and time delay. This closure technique is shown in Fig 2. The pilot model operates on a pitch-attitude error signal which is the difference between the commanded attitude and the aircraft's attitude. The pilot strategy for the Neal-Smith theory is shown in Fig 3. The pilot, through the flying parameters he is observing, tries to achieve a certain "standard of performance" which is defined by a certain closed-loop bandwidth. The bandwidth is defined by the 90° closed-loop phase requirement. At frequencies below the bandwidth, the pilot attempts to minimize tracking errors as defined by a minimum low-frequency droop (no more than -3 dB). The pilot also attempts to minimize the closed-loop resonant peak $\|\theta/\theta_c\|_{\max}$, which minimizes oscillatory tendencies. The lead/lag filter (which is generally a pure lead term for most configurations) and pilot gain are adjusted such that the -3 dB droop and -90° of closed-loop phase conditions are met for a given bandwidth while the closed-loop resonance is minimized. These parameters then provide a measure of compensation with which the pilot closes the loop. The process of obtaining these closed-loop conditions is readily displayed on a Nichols chart. The Nichols chart overlays the open-loop amplitude vs phase grid with the closed-loop amplitude vs phase grid. Thus, the Nichols chart provides instant information regarding the closed-loop performance (unity feedback is

assumed). An example of a successful Neal-Smith solution on a Nichols chart is shown in Fig 4. Once the closed-loop conditions are met, closed-loop resonance and pilot lead/lag for a given bandwidth are plotted on a Neal-Smith parameter plane ($\|\theta/\theta_c\|$ vs pilot compensation) as shown in Fig 5 and then correlated with the pilot ratings for a longitudinal task. Figure 5 illustrates the revised Neal-Smith boundaries that were developed in Ref. 3 for the longitudinal landing task.

Application of Pitch-Attitude Frequency-Domain Criterion

The Neal-Smith analysis performed on the in-flight simulation database showed that a number of configurations were predicted by the criterion to be better than the actual pilot ratings had indicated.¹ A bandwidth of 2.0 rad/sec produced the most representative correlation between the predicted and actual pilot ratings in this analysis. Although the Neal-Smith criterion is a function of both closed-loop resonance and pilot lead/lag, at this bandwidth the configurations generally exhibited satisfactory levels of closed-loop resonance. As a result, it appeared that the variations in the actual pilot ratings were primarily dependent upon the amount of pilot lead compensation required to achieve the Neal-Smith closed-loop requirements. Figure 6 illustrates the relationship between the actual pilot ratings and the pilot lead in pitch attitude required at a bandwidth of 2.0 rad/sec. In addition to the configurations from Ref. 1, selected configurations from Ref. 4 comparable to those from Ref. 1 are shown in Fig. 6. These selected configurations, those of a large aircraft with a short-aft tail, are summarized in Table 2. The pilot ratings for these configurations refer only to the landing performance. The ± 1 pilot rating boundaries in Fig. 6 result in a data correlation of 55%. Note that Fig. 6 shows a significant amount of scatter in the data for a wide range of pilot lead compensation.

The results from Fig. 6, however, display some trends worth noting. The actual pilot ratings appear to degrade as the amount of lead compensation required by the pilot increases for the given bandwidth. This is to be expected, as the pilot would like to achieve the highest possible bandwidth with the least amount of compensation. The basic configurations with pitch rate feedback (sets 1,2,6-1) appear to require more lead compensation than the same configurations with the lead/lag prefilter. The lead/lag prefilter appears to reduce the amount of lead compensation required by the pilot at the given bandwidth (sets 4,5,6-2). Thus, as the prefilter restores the configuration's original $1/T_{\theta 2}$, the amount of pilot lead required is reduced and this results in improved pilot ratings. The conventional configuration (set 7) which consistently produced level I pilot performance⁵ required relatively little lead compensation, as did some of the prefilter configurations. The Shuttle-like

configurations (set 8) generally required the largest amount of lead compensation and displayed degraded pilot ratings. Most of the configurations that included a washout filter (the four-digit configurations) were rated better than would be expected based on the amount of pilot lead required, this is caused by the washout frequency range being below 0.2 rad/sec, which is considerably below the given bandwidth for pitch attitude. Most of the configurations from Table 2 correlated well with the trend in Fig. 6. The overall indications from Fig. 6 point out that pitch-attitude characteristics alone are not the primary variable for the flared landing task.

Altitude-Rate Frequency-Domain Criterion

Pilot comments indicated that altitude rate control was a significant factor in the evaluation of touchdown performance.¹ An attempt was made in Ref. 1 to close the loop directly on altitude rate at the pilot station using a pilot model which operated with a gain and time delay. A relationship was found between the altitude-rate bandwidth and the actual pilot ratings, which showed only a slight improvement over the pitch-attitude criteria. As a result, an alternate method to evaluate altitude-rate control was developed as described in the following section.

Technique Description

Assuming that the pilot closes the loop on altitude rate in a manner similar to pitch attitude, an investigation was made into the closed-loop performance of altitude rate using the Neal-Smith technique. Figure 7 illustrates the loop closure in block diagram form. Altitude rate at the pilot station is controlled directly using a pilot model which employs a lead filter with a gain and time delay, as in Neal-Smith theory. The closed-loop requirements, as before, were -3 dB of droop and -90° of phase at the given bandwidth. This method was then applied to the database.

Application of Altitude-Rate Criterion

As with the Neal-Smith technique, this method uses a closed-loop bandwidth as one measure of pilot performance. After several iterations, an altitude-rate bandwidth of 1.3 rad/sec appeared to best represent the data. In general, the maximum resonance at this bandwidth was low for the configurations, and the amount of pilot lead for altitude-rate control appeared to be the dominating factor in the pilot model. Figure 8 shows the relationship between the actual pilot ratings and the amount of pilot lead in altitude rate. Also included in Fig. 8 are the configurations from Table 2. As with pitch-attitude lead, the actual pilot ratings appear to degrade as the requirement for altitude-rate lead increases for the given bandwidth. The ± 1 pilot ratings boundaries show a data correlation of 60%, a slight improvement over the pitch-attitude analysis. Note that Fig. 8

shows an improvement in the data scatter relative to the pitch-attitude data in Fig. 6.

The altitude-rate lead requirements in Fig. 8 appear to discriminate a number of the configurations. The basic configurations with pitch-rate feedback (sets 1,2,6-1) generally require more lead in altitude rate than the same configurations with a lead/lag prefilter (sets 4,5,6-2). This trend corresponds with the actual pilot ratings. The conventional configuration (set 7) displayed an altitude-rate lead representative of the prefilter configurations. The Shuttle-like configurations (set 8) generally showed higher lead requirements and correlated well with the actual pilot ratings. The washout configurations (the four-digit configurations) were generally rated better than the altitude-rate lead requirements would indicate, which is again due to the low-frequency feature of washout filter. The configurations from Table 2 showed poor correlation with the trend shown in Fig. 8. Despite this point, the trends mentioned above echoed those found with the pitch-attitude lead requirements.

The relationship between the pilot ratings from this database and the results from the single-loop closure techniques have provided some insight into the flying qualities obtained with these configurations. However, the results from these single-loop closure techniques do not appear to give an accurate picture of the longitudinal landing task. It is possible that control of more than one parameter is required by the pilot to achieve satisfactory performance. In this instance, the pilot may elect to control one parameter in series with another during the longitudinal landing task.

Altitude Criterion with Attitude Inner-Loop Closure

In an effort to obtain a criterion that would better encompass the wide range of characteristics found in this database, an investigation was made into the closed-loop performance of the pilot using multiloop control. This technique assumes that the pilot controls altitude through pitch attitude to provide satisfactory longitudinal control during landing.

Technique Description

In the instance when the pilot desires to control altitude, this task is performed by closing an inner loop on pitch attitude and an outer loop on altitude. In this way an altitude error is translated into a pitch command. Figure 9 shows the closure technique in block diagram form. The pitch-attitude loop can be closed using the classical Neal-Smith approach with a pilot model consisting of a lead/lag filter with a gain and time delay. The altitude outer loop can then be closed through a pilot model operating with a pure gain.

Following the closure of the pitch-attitude loop, the altitude loop was closed to determine the bandwidth available for altitude control. The altitude bandwidth is the frequency at which a satisfactory level of closed-loop resonance (2-4 dB) at -90° of closed-loop phase is achieved. A typical altitude outer-loop closure is shown on a Nichols chart in Fig 10.

Application of Altitude Criterion with Attitude Inner-Loop Closure (Attitude Bandwidth Fixed)

An example of this multiloop technique is found in Ref. 4. This method specifies the inner loop as a result of the Neal-Smith attitude closure at a given bandwidth. The multiloop technique of Ref. 4 was applied to the observed data, and the resulting altitude bandwidths for the configurations were plotted against the corresponding actual pilot ratings, as shown in Fig. 11. The inner-loop attitude bandwidth remained at 20 rad/sec for all configurations (since this correlated best, as indicated earlier). Also included in Fig. 11 are the configurations from Table 2. Overall, the results from Fig. 11 show a data correlation of 64% within ± 1 pilot rating. This is a slight improvement over the two previous single-loop closure techniques. However, the data in Fig 11 do not show adequate continuity and separation throughout the bandwidth range. The basic configurations with pitch-rate feedback (sets 1,2,6-1) do not adequately show the improvement (higher altitude bandwidth) found in the actual pilot ratings with the addition of the lead/lag prefilter (sets 4,5,6-2). The conventional configuration (set 7) displayed one of the higher attainable bandwidths. The Shuttle-like configurations (set 8) displayed some of the lower bandwidths. Two of these configurations (8-2-5, 8-3-5-1) deviated significantly from the observed trends. The Shuttle-like canard configuration (8-4-6) was assigned a pilot rating of 1 and had the highest attainable bandwidth (275 rad/sec). Most of the configurations from Table 2 were not consistent with the trend observed in Fig 11.

A possible shortcoming of this method is that the inner-loop attitude compensation is based upon a given bandwidth. The pilot may not need all the attitude compensation provided by some of the configurations at this given bandwidth. Ideally, the pilot will attain an inner-loop bandwidth which provides adequate inner-loop control such that he may then control the outer loop. The inner-loop bandwidth will then vary for each configuration. This must be taken into account when applying a multiloop technique of this type to handling qualities data.

Application of Altitude Criterion with Attitude Inner-Loop Closure (Attitude Lead Compensation Fixed)

The focal point of this paper is the technique of defining the inner-loop pilot model such

that the altitude performance characteristics can be defined by a single metric. For the configurations of this study, pilot lead compensation is required to improve the pitch-attitude control. However, it is assumed that this pilot compensation in pitch is provided to ensure good altitude characteristics rather than a good attitude "tracker," as such. Therefore, in order to provide a consistent inner-loop strategy between configurations, it is assumed that the pilot will provide an amount of inner-loop pitch-attitude lead consistent with level I handling qualities and then examine the resulting altitude outer-loop performance. From Fig. 5, it can be seen that 25° of lead compensation is consistent with level I pilot ratings. The inner-loop pilot model (lead and gain) was then determined from the classical Neal-Smith solution that provided 25° of lead compensation (which corresponds to a bandwidth of 18 rad/sec for the particular example in Fig 5). Each configuration will achieve a different pitch-attitude bandwidth for the 25° pilot model lead compensation. Following the closure of the pitch-attitude loop, the altitude loop was closed to determine the bandwidth available for altitude control. These loop closures are identical to the previously mentioned multiloop technique and are shown in block diagram form in Fig 9.

The parameter of primary interest in this technique, as before, is the altitude bandwidth. The major feature of this technique, however, is the elimination of specifying an inner-loop bandwidth and the emphasis upon level I inner-loop attitude compensation. If the pilot cannot attain adequate altitude bandwidth with a reasonable amount of pitch-attitude compensation, the pilot ratings will suffer. Therefore, altitude bandwidth attained with pilot compensation in pitch that corresponds to good flying qualities will be a measure of flare and landing flying qualities. Figure 12 illustrates the relationship between the altitude bandwidth using this technique and the actual pilot ratings for this database. Again, the configurations from Table 2 are included in Fig 12. The results in Fig 12 indicate a distinct relationship between altitude bandwidth and actual pilot ratings. The ± 1 pilot rating bounds result in a data correlation of 73%, which is significantly higher than the pilot rating correlations found with altitude rate or pitch attitude. These results also show good continuity and separation throughout the bandwidth range, unlike the results in Fig 11 which are based upon the constant inner-loop/bandwidth approach. The basic configurations with pitch-rate feedback (sets 1,2,6-1) show a lower altitude bandwidth than the same configurations with the lead/lag prefilter (sets 4,5,6-2). The "conventional" configuration (set 7) displayed one of the higher attainable bandwidths. The Shuttle-like configurations (set 8) displayed some of the lower bandwidths, with some exceptions noted. The Shuttle-like canard configuration (8-4-6) was assigned a pilot rating of 1 and had the highest attainable

altitude bandwidth (2.5 rad/sec). Another Shuttle-like configuration with a washout filter (8-3-5-1) was assigned a pilot rating of 2, but had a very low bandwidth. The remaining washout configurations appear to correlate well. The configurations from Table 2 correlated very well with the other data in Fig. 12. The overall trend in Fig. 12 shows that a minimum altitude bandwidth of 0.4 rad/sec appears to be necessary for level I pilot performance. It should also be noted that, although the overall correlation of data with this technique is better than that of Ref. 4, the level I boundary for bandwidth is similar (0.5 rad/sec in Ref. 4).

The relationship between the inner-loop pitch-attitude bandwidth and the outer-loop altitude bandwidth from Fig. 12 is worth noting, as shown in Fig. 13. It appears that good altitude bandwidth requires good inner-loop pitch attitude bandwidth, which is to be expected. The capabilities of modern control systems allow considerably more variation in altitude bandwidth for a given attitude bandwidth than has been possible in the past. As a result, attitude control cannot be used without consideration of the altitude response.

Conclusions

Three frequency-domain handling qualities criteria were applied to the observed data to correlate the actual pilot ratings assigned to generic transport configurations with stability augmentation during the longitudinal landing task. The criteria were based on closed-loop techniques using pitch attitude, altitude rate at the pilot station, and altitude at the pilot station as dominating control parameters during this task. The application of these criteria to the observed data have produced the following conclusions:

1) The Neal-Smith analysis using pitch attitude did not correlate well with the observed data. The amount of pilot lead compensation in pitch attitude required by the Neal-Smith analysis was compared with the actual pilot ratings and a data correlation of 55% within ± 1 pilot rating resulted. These results indicated that pitch-attitude control may not be the primary task of the pilot in landing a highly augmented generic transport aircraft.

2) Altitude rate was evaluated using the Neal-Smith analysis. Again, the amount of lead

compensation required by the Neal-Smith analysis was compared with the actual pilot ratings and a data correlation of 60% within ± 1 pilot rating resulted. This is slightly better than that determined from pitch attitude. Despite this point, it appears that altitude rate control may not be the primary task of the pilot in landing a highly augmented generic transport aircraft.

3) Altitude control performed by closing an inner loop on pitch attitude and closing an outer loop on altitude produced the most promising results. This method assumed that the pilot will provide an amount of inner-loop pitch-attitude compensation consistent with level I handling qualities and then examine the resulting altitude outer-loop performance. As a result, a data correlation of 73% within ± 1 pilot rating was determined from altitude bandwidth. A minimum altitude bandwidth of 0.4 rad/sec appeared necessary for level I performance.

The capabilities of modern control systems allow considerably more variation in altitude bandwidth for a given attitude bandwidth than has been possible in the past. As a result, attitude control cannot be used without consideration of the altitude response. Overall, it appears that control of altitude is a dominant task for the pilot during landing.

References

¹Berthe, C. J., Chalk, C. R., and Sarrafian, S. K., "Pitch Rate Flight Control Systems in the Flared Landing Task and Design Criteria Development," NASA CR-172491, Oct. 1984.

²Neal, T. P. and Smith, R. E., "An In-Flight Investigation to Develop Control System Criteria for Fighter Airplanes," AFFDL-TR-70-74, Vols I and II, Dec. 1970.

³Radford, R. C., Smith, R. E., and Bailey, R. E., "Landing Flying Qualities Evaluation Criteria for Augmented Aircraft," NASA CR-163097, Aug. 1980.

⁴Weingarten, N. C. and Chalk, C. R., "In-Flight Investigation of Large Airplane Flying Qualities for Approach and Landing," AFWAL-TR-81-3118, Sept. 1981.

⁵"Military Specification Flying Qualities of Piloted Airplanes," MIL-F-8785C, Nov. 1980.

Table 1 Configuration Summary q/F_{es} Transfer Function^a

$$\frac{q}{F_{es}} = \frac{(s + K_I)(s + 1/T_{\theta 2})}{(s + \lambda_2^i)(\omega_{nsp}, \rho_{sp})} \frac{(s + 1/T_Z)}{(s + 1/T_F)} \frac{s}{(s + 1/T_{wo})}$$

prefilter washout

Configuration ^b	K _I	1/T _{θ2}	λ ₂ ⁱ	(ω _{nsp} , ζ _{sp})	1/T _Z	1/T _F	1/T _{wo}	Cooper-Harper pilot ratings
1-1-1	2.0	0.38	0.44	2.79, 0.8	--	--	--	5, 7
(1-2-2)	2.0	0.72	0.82	2.76, 0.8	--	--	--	5, 5, 7, 8
1-3-7	2.0	1.00	1.19	2.73, 0.8	--	--	--	3, 4, 7
2-1-1	2.0	0.38	0.50	1.78, 0.6	--	--	--	5, 6, 7
2-2-2	2.0	0.72	0.93	1.75, 0.6	--	--	--	3, 4, 5
3-1-3	0	0.38	2.50	0.036, 4.94	--	--	--	5.5, 6
3-2-4	0	0.72	2.50	0.063, 5.24	--	--	--	2, 5, 5
4-1-1	2.0	0.38	0.44	2.79, 0.8	0.435	2.0	--	2, 5, 5
4-2-2	2.0	0.72	1.19	2.73, 0.8	0.821	2.0	--	2, 3
(4-3-7)	2.0	1.00	1.19	2.73, 0.8	1.19	2.0	--	7
4-3-7-1	2.0	1.00	1.19	2.73, 0.8	1.19	2.0	0.20	4
5-1-1	2.0	0.38	0.50	1.78, 0.6	0.50	2.0	--	4.5, 4.5
5-2-2	2.0	0.72	0.93	1.75, 0.6	0.931	2.0	--	2, 3
6-1-1	3.0	0.38	0.45	2.27, 0.46	--	--	--	3, 5, 6, 6
6-1-1-1	3.0	0.38	0.45	2.27, 0.46	--	--	0.20	3
6-2-1	3.0	0.38	0.45	2.27, 0.46	0.448	3.0	--	2, 5, 5
6-2-1-1	3.0	0.38	0.45	2.27, 0.46	0.448	3.0	0.20	3
7-1-4	--	0.72	0	2.84, 0.80	--	--	--	2, 5, 3
8-1-5	2.0	0.40	0.586	1.45, 0.50	0.6	2.0	--	4, 5, 5, 6
8-1-5-1	2.0	0.40	0.586	1.45, 0.50	0.6	2.0	0.20	2
8-2-5	2.0	0.40	0.70	1.09, 0.50	1.0	2.0	--	7, 8, 8
(8-2-5-1)	2.0	0.40	0.70	1.09, 0.50	1.0	2.0	0.20	7
8-3-5	2.0	0.40	0.586	1.45, 0.50	1.5	2.0	--	5, 7, 7, 8
8-3-5-1	2.0	0.40	0.586	1.45, 0.50	1.5	2.0	0.20	3, 3
8-4-6	2.0	0.40	0.590	1.47, 0.60	0.6	2.0	--	1
8-5-5	2.0	0.40	0.586	1.45, 0.50	0.6	2.0	--	5, 7

^aFeel system = (21.0, 0.60)

Actuator = (27.0, 0.70)

^bFirst number of each configuration refers to the set number

() indicate data considered suspect, not included in analysis

Table 2 Large Aircraft Configuration Summary (Ref. 4)

Configuration	Description	Cooper-Harper pilot ratings ^a
LA12	Short-aft tail, medium α feedback	10
LA13	Short-aft tail, high α feedback	9, 8
LA13A	Short-aft tail, high α feedback (different stick feel system than LA13)	10
LA14	Short-aft tail, medium q feedback	9
LA15	Short-aft tail, high q feedback	9
LA15A	Short-aft tail, high q feedback (different stick feel system than LA15)	6

^aRefers to ratings assigned to landing task only

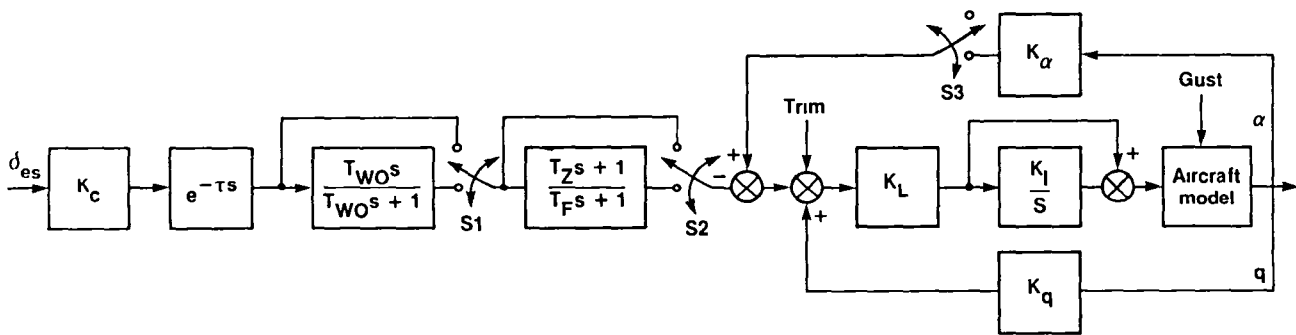

Fig. 1 Pitch-rate flight-control system (Ref. 1).

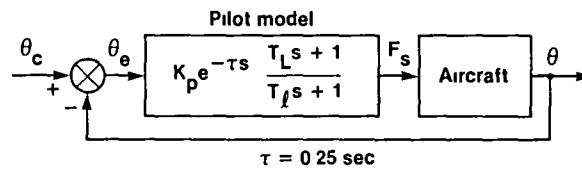

Fig. 2 Classical Neal-Smith closure technique.

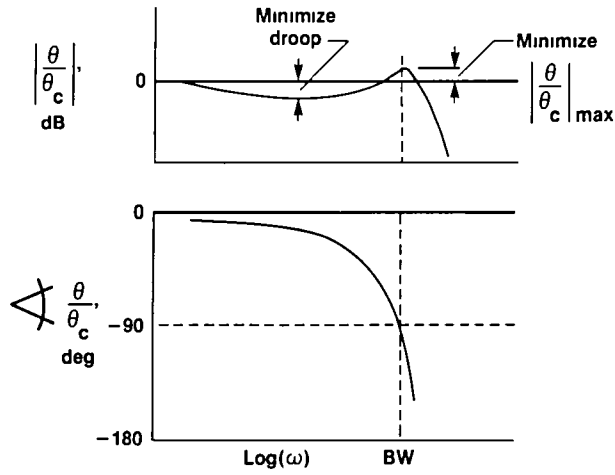

Fig. 3 Neal-Smith pilot strategy (closed-loop pilot/vehicle frequency response).

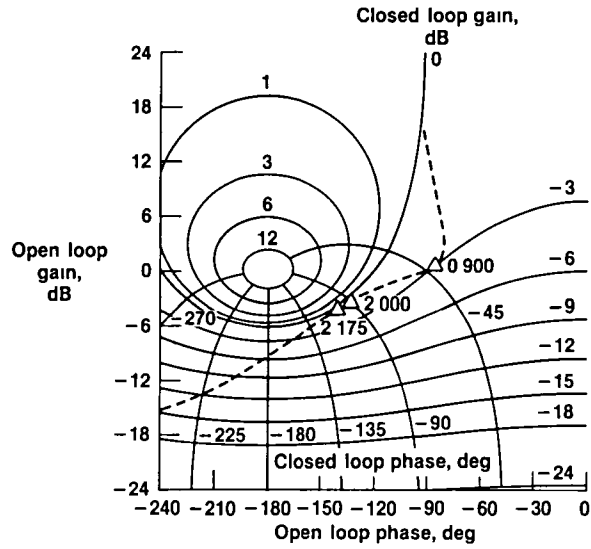

Fig. 4 Neal-Smith solution. Bandwidth = 2.0 rad/sec. Dashed line represents closed-loop pilot/vehicle pitch attitude frequency response.

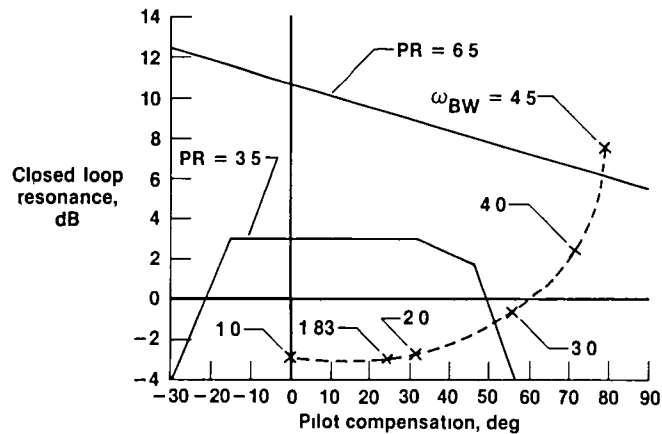

Fig. 5 Neal-Smith solution (Neal-Smith parameter plane).

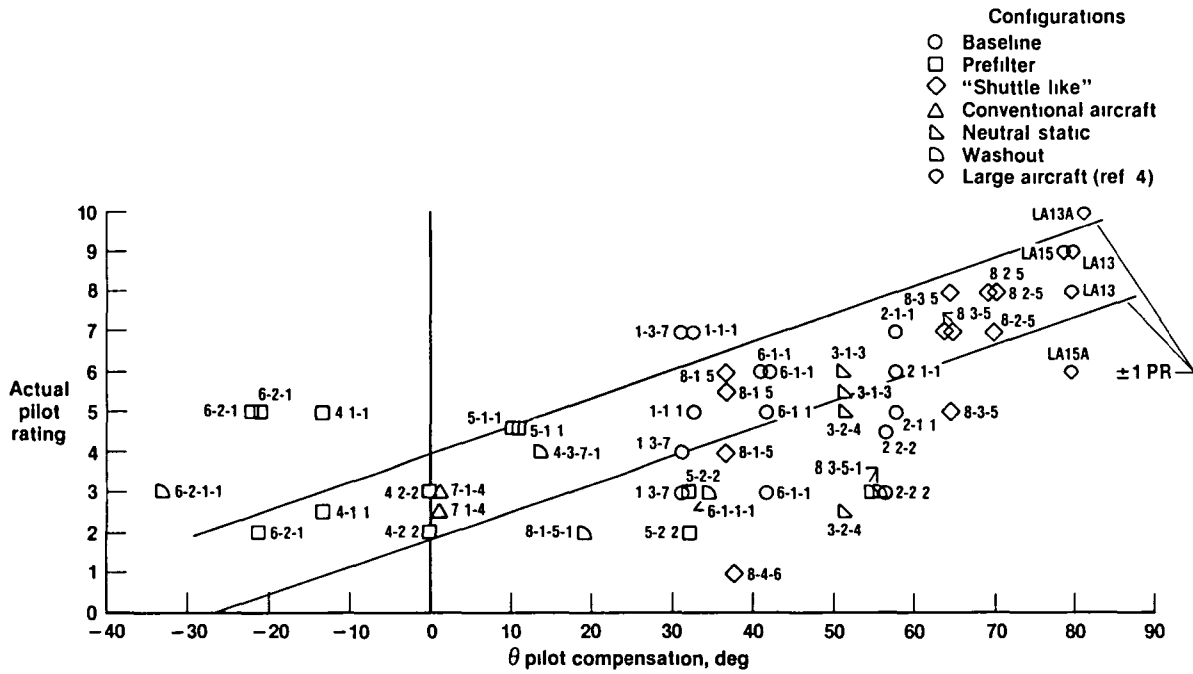

Fig. 6 Pilot rating as a function of θ pilot compensation. $WBW_{\theta} = 2.0$ rad/sec.

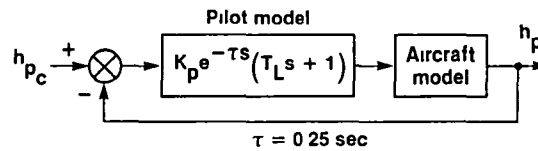

Fig. 7 Altitude rate (pilot) closure technique.

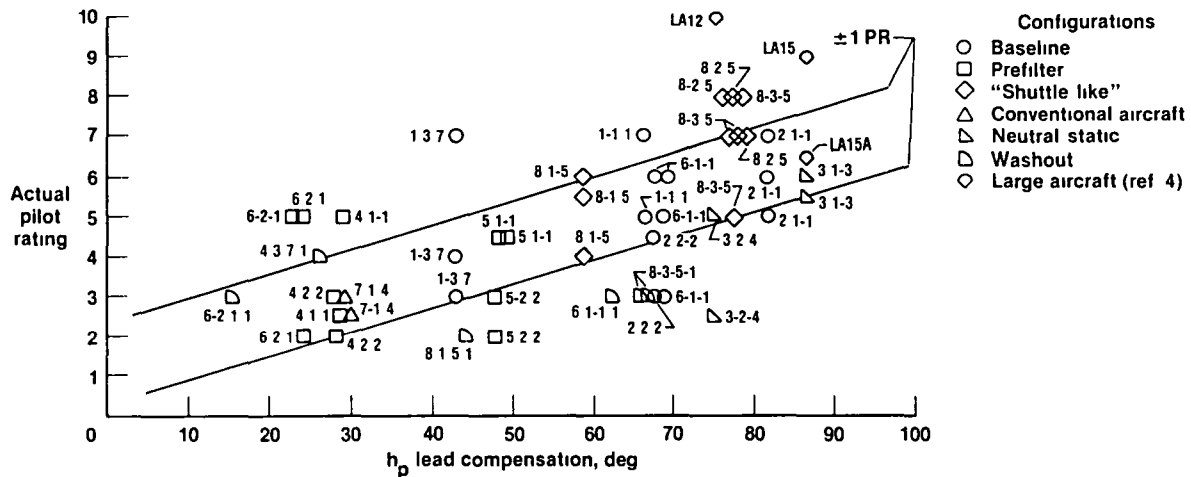

Fig. 8 Pilot rating as a function of h_p pilot compensation. $WBW_{h_p} = 1.3$ rad/sec.

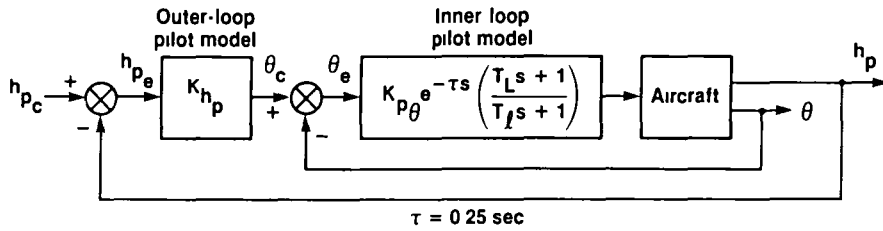

Fig. 9 Altitude outer-loop closure technique with attitude inner-loop closure (θ lead 25°).

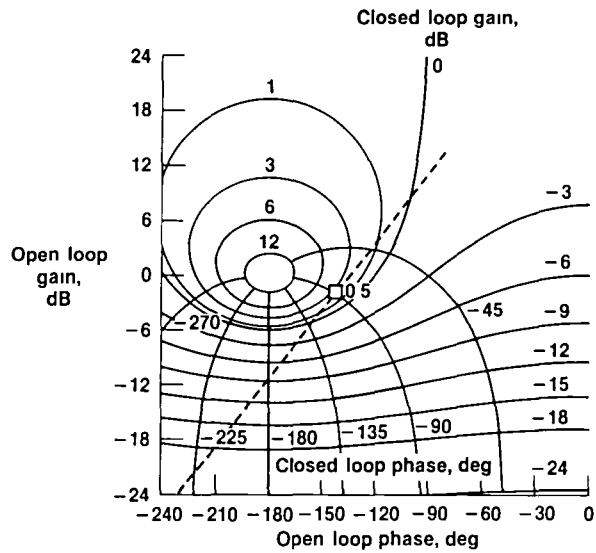

Fig. 10 Altitude outer-loop closure with pitch-attitude inner-loop closed ($W_{BW_{h_p}} = 0.5$ rad/sec).

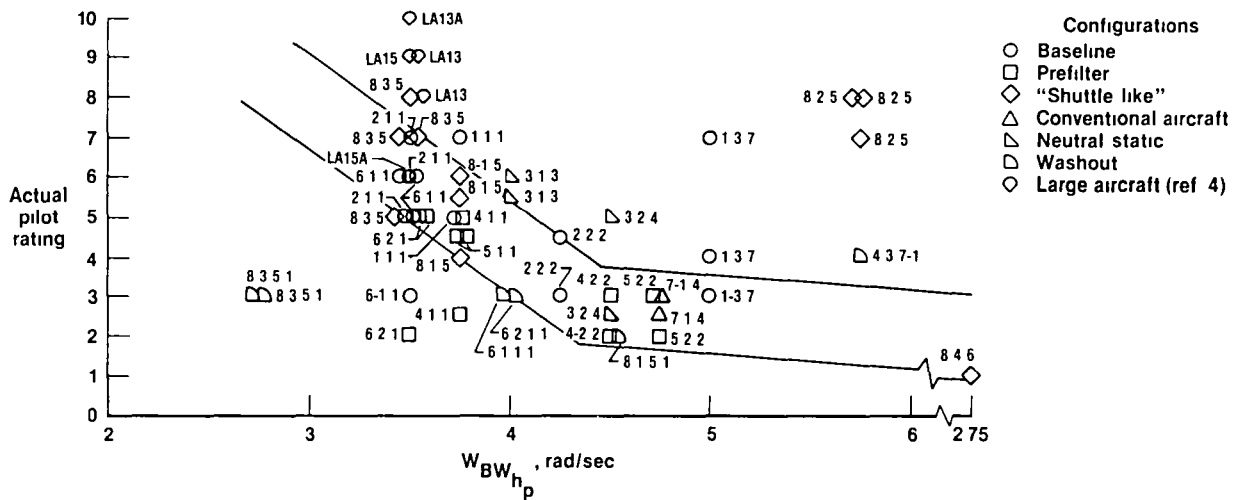

Fig. 11 Pilot rating as a function of altitude bandwidth (θ inner-loop results in $W_{BW_{\theta}} = 2.0$ rad/sec).

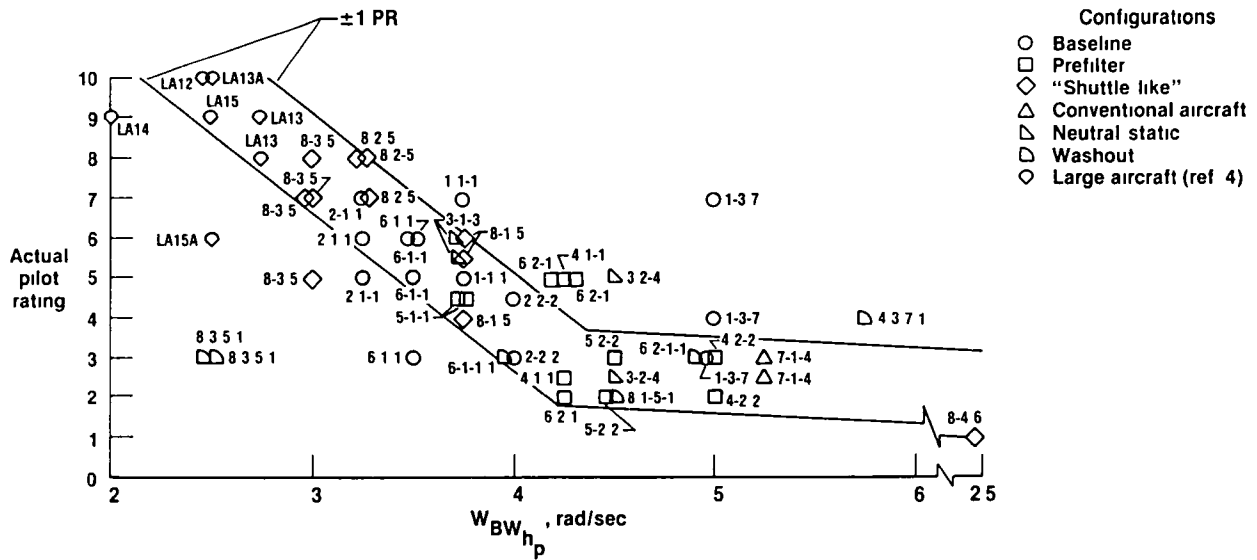

Fig. 12 Pilot rating as a function of altitude bandwidth (8 inner-loop results in 25° lead compensation).

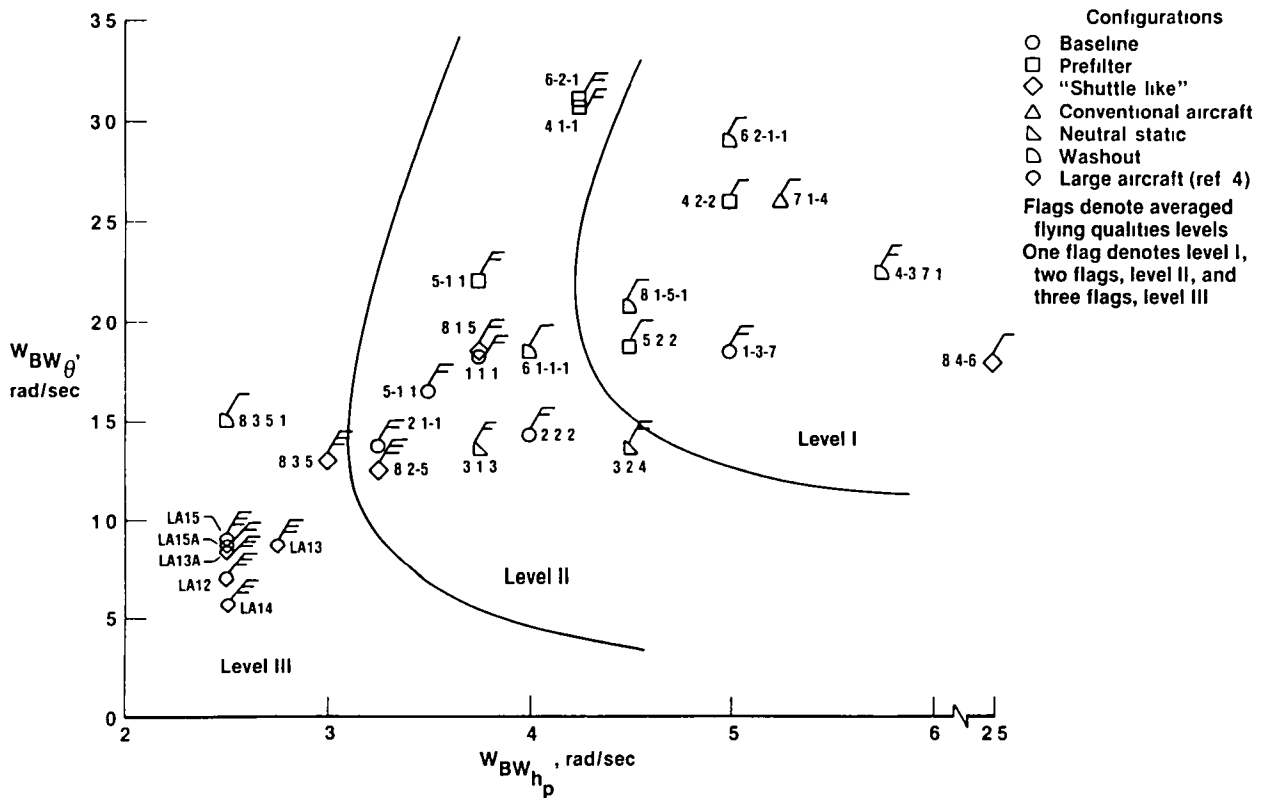

Fig. 13 $W_{BW_{\theta}}$ as a function of $W_{BW_{h_p}}$ (results from Fig. 12).

1 Report No NASA TM-86728	2 Government Accession No	3 Recipient's Catalog No	
4 Title and Subtitle Application of Frequency Domain Handling Qualities Criteria to the Longitudinal Landing Task		5 Report Date August 1985	6 Performing Organization Code
		8 Performing Organization Report No H-1288	10 Work Unit No RTOP 505-43-11
7 Author(s) Shahan K. Sarrafian and Bruce G. Powers		11 Contract or Grant No	
		13 Type of Report and Period Covered Technical Memorandum	
9 Performing Organization Name and Address NASA Ames Research Center Dryden Flight Research Facility P.O. Box 273 Edwards, CA 93523-5000		14 Sponsoring Agency Code	
		12 Sponsoring Agency Name and Address National Aeronautics and Space Administration Washington, D.C. 20546	
15 Supplementary Notes Prepared as AIAA Paper 85-1848 for presentation at the AIAA Guidance, Navigation, and Control Conference, Snowmass, Colorado, August 19-21, 1985.			
16 Abstract Under NASA sponsorship, an in-flight simulation of the longitudinal handling qualities of several configurations for the approach and landing task was performed on the USAF/AFWAL Total In-Flight Simulator by the Calspan Corporation. The basic configuration was a generic transport airplane with static instability. The control laws included proportional plus integral gain loops to produce pitch-rate and angle-of-attack feedback loops. The evaluation task was a conventional visual approach to a flared touchdown at a designated spot on the runway with a lateral offset. The general conclusions were that the existing criteria are based on pitch-attitude response and that these characteristics do not adequately discriminate between the good and bad configurations of this study. This paper describes the work that has been done to further develop frequency-based criteria in an effort to provide better correlation with the observed data.			
17 Key Words (Suggested by Author(s)) Handling qualities Control systems Landing task		18 Distribution Statement Unclassified - Unlimited STAR category 08	
19 Security Classif (of this report) Unclassified	20 Security Classif (of this page) Unclassified	21 No of Pages 13	22 Price* A02

*For sale by the National Technical Information Service, Springfield, Virginia 22161.

End of Document