

NASA Technical Memorandum 87096

Lubrication and Cooling for High Speed Gears

(NASA-TM-87096) LUBRICATION AND COOLING FOR
HIGH SPEED GEARS (NASA) 24 p HC A(2/MP A(1
CSCL 131

N85-34407

Unclas

33/37

22226

Dennis P. Townsend
*Lewis Research Center
Cleveland, Ohio*

Prepared for the
Lubrication Session of the
Original Equipment Manufacturing Design Conference
Philadelphia, Pennsylvania, September 9-11, 1985



LUBRICATION AND COOLING FOR HIGH SPEED GEARS

Dennis P. Townsend
National Aeronautics and Space Administration
Lewis Research Center
Cleveland, Ohio 44135

SUMMARY

The problems and failures occurring with the operation of high speed gears are discussed. The gearing losses associated with high speed gearing such as tooth mesh friction, bearing friction, churning, and windage are discussed with various ways shown to help reduce these losses and thereby improve efficiency.

Several different methods of oil jet lubrication for high speed gearing are given such as into mesh, out of mesh, and radial jet lubrication. The experiments and analytical results for the various methods of oil jet lubrication are shown with the strengths and weaknesses of each method discussed.

The analytical and experimental results of gear lubrication and cooling at various test conditions are presented. These results show the very definite need of improved methods of gear cooling at high speed and high load conditions.

INTRODUCTION

There are many applications where gears must operate at high speeds >50 m/s (10 000 fpm) and sometimes at high tooth loading. Some of these applications include turbine powered ship propulsion, surface effect ships, turbo-prop, V/STOL aircraft, and geared turbofans. There is very little information available on lubrication and cooling methods, or methods to determine the power losses and lubrication requirements for gears operating at these high power conditions. Many high speed gear sets today are operating at load conditions below those that could be obtained with better cooling methods. Also many gear boxes could operate at better efficiencies with improved lubrication and cooling methods.

There are several methods used for lubrication and cooling gears. Some of these methods include splash lubrication, drip feed, grease, oil mist, and low or moderate pressurized oil jet flow. Some gear boxes are operated with a given lubrication method such as low pressure oil jets with into mesh and/or out of mesh simply because it has worked in the past and no effort has been made to improve the system for better efficiency or higher power rating.

For gears operating at low speeds and low loads the lubrication method is not critical since very little heat is generated. Under these conditions the gears require lubrication but very little cooling. When the heat input to the gear teeth is increased by high speed and high power conditions then the majority of the lubricant must be used for cooling the gear teeth. When inadequate cooling is supplied to the gear teeth several things may happen. The gear teeth can suffer what is called micropitting or grey staining (fig. 1, ref. 1) which is caused by insufficient oil film between the teeth. The gears can have early fatigue spalls (fig. 2, ref. 2) resulting from reduced hardness caused by a temperature rise of the gear teeth above the gear tempering temperature. The gears can fail by scoring (fig. 3, ref. 3) as a result of a loss of the elasto-hydrodynamic EHD or extreme pressure EP boundary film. The gears can also fail by tooth breakage as a result of reduced strength when the teeth are overheated and lose their hardness. The objective of the work reported herein is to show the gear designer the various lubrication methods that are used in gearing and what can be expected with each method, and to provide the gear designer with methods to reduce gear losses and thereby reduce heating and improve efficiency.

NOMENCLATURE

- A bearing area, cm^2 (in^2)
- a addendum, mm (in)
- B backlash, mm (in)

c_p specific heat, cal/g °C (Btu/lb °F)
 c_s basic static capacity, N (lb)
 D root diameter, mm (in)
 d gear diameter, mm (in)
 d_i impingement depth, mm (in)
 d_m bearing mean diameter, mm (in)
 F face width, mm (in)
 F_a bearing axial load, N (lb)
 F_B bearing load, N (lb)
 F_r bearing radial load, N (lb)
 F_s static equivalent load, N (lb)
 f_0 friction factor viscosity
 f_l friction factor load
 h_l bearing clearance, mm (in)
 L_p distance from impingement point to center line of gears, mm (in)
 M tooth module, mm
 M_b bearing friction torque, N-m (lb-in)
 M_l bearing load friction torque, N-m (lb-in)
 M_v bearing viscous friction torque, N-m (lb-in)
 m_g gear ratio
 N speed, rpm
 P power loss, kW
 P_d diametrial pitch, 1/in
 ΔP oil jet pressure, N/cm (lb-in)
 Q heat loss, cal/min (Btu/min)
 R pitch radius, mm (in)
 r radius to oil jet impingement, mm (in)

- r_o gear outside radius, mm (in)
- S_j oil jet offset, mm (in)
- ΔT oil temperature rise, °C (°F)
- V velocity, mm/sec (in/sec)
- V_g gear pitch line velocity, m/sec (ft/sec)
- V_j oil jet velocity, m/sec (ft/sec)
- w oil flow, g/min (lb/in)

Greek symbols

- α bearing contact angle, degrees
- β oil jet angle, radians
- γ nondimensional impingement depth = $d_i/\text{whole depth}$
- θ_w gear rotation angle for oil jet in tooth space, radians
- λ gearbox space function 1=free space, 0.6-0.7 for large enclosure, 0.5-0.6 for fitted gear case
- μ viscosity, reyns
- ν_o lubricant viscosity, centistokes
- ϕ oil mixture function 1.0=oil free atmosphere
- ϕ_g gear pressure angle, radians
- ω_g gear rotational speed, radians/sec

POWER LOSSES

There are four main areas of losses in high speed gears. These losses can be controlled for the most part by careful design and construction. The losses consist of bearing losses, tooth friction losses, oil churning losses, and gear windage losses. Bearing losses may account for about half of the losses particularly when fluid film bearings are used. However, when long life is a requirement, the fluid film bearing is the best choice. An approximate method for the friction torque in a fluid film bearing is shown in the following equation from reference 4.

$$M_b = \mu ArV/h \quad (1)$$

Rolling contact bearings have considerably less friction loss when properly lubricated and will generally have a much shorter life than a fluid film bearing. However, rolling element bearings should have sufficient life for many applications. The friction torque for rolling element bearings may be estimated by the following equations from reference 5.

$$M_b = M_l + M_v$$

The friction torque due to the applied load is

$$F_B = 0.9 F_a \cot \alpha - 0.1 F_r \quad \text{or} \quad F_B = F_r \quad \text{if larger}$$

$$M_l = f_l F_B d_m \quad (2)$$

where $f_l = z \left(\frac{F}{C_s} \right)^y$, $z = 0.001$, $y = 0.33$

for 30 angle contact bearings and $f_l = 0.0003$ for roller bearings. The viscous friction torque may be estimated by

$$M_v = 1.42 \times 10^{-5} f_o (v_o N)^{2/3} d_m^3 \quad (3)$$

$$M_v = 3.492 \times 10^{-3} f_o d_m^3 \quad v_o N \leq 2000$$

for ball bearings f_o values range from 3 to 4. Bearing computer programs have been developed that give more accurate results for bearing torque, (refs. 6 and 7).

The tooth friction loss is probably the lowest loss in the gear system when the gears are adequately lubricated. There is very little that can be done to reduce gear tooth friction loss once adequate lubrication has been provided. Some lubricants will have a little less friction loss than others. Some gears will have more or less tooth friction loss because of the type of design mainly because of the different sliding conditions. For instance, high

contact ratio spur gears generally have more sliding and, hence, more losses than standard contact ratio gears. However, since this is a small part of the overall loss, it generally has little effect on the total loss.

Windage losses can account for a large part of the total gear box losses in high speed gears because of the high pitch line velocities. Some of this windage loss can be reduced by careful designs. For instance, it was shown in reference 8 that axial holes in a gear web can significantly increase the windage losses. Also it was shown that placing a shield on the ends of the gear teeth, to prevent the air circulating into the teeth, reduced the windage losses by a large percentage. The windage losses in a gear box with the smooth sides of the box located approximately 1 in from the gear and the inside diameter 0.6 in from the teeth, reduced the windage loss to approximately one-half that for open gears. The pumping loss of the air at the entrance of the mesh accounts for some losses and can be reduced by reducing the pressure in the gear box which also reduces other windage losses. An equation for approximating the windage loss in gears was given in reference 8 as shown in the following equation.

$$P = N^{2.9} \left(\overset{\text{Sides}}{0.16 D^{3.9}} + \overset{\text{Periphery}}{D^{2.9} F^{0.75} M^{1.15}} \right) \times 10^{-20} \cdot \Phi \cdot \lambda \quad (4)$$

Churning losses are caused by the gear striking, pumping, or otherwise moving the lubricant around in the gear box. It is very important in high speed gear boxes to get the lubricant to perform its lubrication and cooling function and then get it out of the way. Shrouds are sometimes used in gear boxes to direct the lubricant oil away from the gears. If too much lubricant is allowed to enter the gear mesh, excessive losses will occur from oil being trapped in the gear teeth and being pumped out of the mesh in the axial direction. In spur gear application this is more critical than helical gears. This

is one reason why most gear designers prefer helical gears for high speed gearing. Even with helical gearing, however considerable power loss occurs with too much oil getting into the gear mesh. Some spur gear designs have a groove in the center of the axial length of the gear to reduce pumping losses in the mesh. This is also done in some very wide helical gear applications.

LUBRICATION AND COOLING METHODS

There are many high to moderately loaded high speed gears operating today with oil jet lubrication using 30 to 50 psig oil pressure to lubricate the gears. This type of low pressure system does not do a good job of cooling the gears in a high speed gear drive and will only allow the gears to operate at a moderate load. In a low pressure oil jet system the oil jet can only penetrate a small distance into the tooth space. This results in cooling of the tips of the gear teeth only. This causes the gear tooth temperature to be higher than that obtained with a better system, such as high pressure radial oil jet. Figure 4(a) is a calculated temperature profile of a gear tooth cooled with low pressure operating at a moderate speed and high load reference 9. When the speed is increased at this load condition and low pressure lubrication, failure of the gears will generally occur. Figure 4(b) shows how the gear tooth temperatures are reduced when the oil jet pressure is increased to obtain good impingement depth.

OUT OF MESH JET LUBRICATION

A large number of gears are lubricated with low pressure oil jets into mesh or out of mesh or both. In the out of mesh lubrication method the oil jet has a very modest impingement depth. This is illustrated in figure 5 which shows the analytical results for impingement depth on the pinion using the following equation from reference 10.

$$d_1 = r_o - \sqrt{r^2 + L_p^2} \quad (5)$$

Figure 6 is a high speed photograph of an oil jet at the out of mesh condition. In order to get the maximum impingement depth for the out of mesh condition care must be exercised to get the proper oil jet location. The analysis indicates that the pinion can be completely missed by a very small change in offset distance from the intersection of the outside diameter of the gear and pinion or from a small change in the jet angle. For maximum impingement depth in most cases the oil jet should be directed at the intersection of the two outside diameters at an angle that will intersect the pitch point of the gear and pinion (ref. 10). For large gear ratios it is probably better to favor the pinion to get a better cooling balance. Reference 11 gives an analytical method for out of mesh jet lubrication for gears with modified center distance and/or addendums. Reference 11 also gives the impingement depth results for various oil jet offsets and oil jet angles. Figure 7 shows the analytical results for the out of mesh jet lubrication for various oil jet angles.

INTO MESH JET LUBRICATION

Into mesh oil jet lubrication is often used as a means of getting oil to the gear tooth surfaces at a good impingement depth when the oil system is operating at a low pressure. This method is effective because it uses the gear tooth velocity moving with the oil jet velocity as shown in figure 8. References 12 and 13 give equations for the oil jet impingement depth for into mesh lubrication. When the jet velocity is less than the gear velocity, the oil impinges on the backside of the teeth as shown in figure 9. When the jet velocity is greater than the gear velocity, the oil will impinge on the front of the gear tooth. This is shown in figure 8. The optimum impingement depth for into mesh lubrication was shown in references 12 and 13 to occur when the oil jet velocity and gear velocity are equal. The equation for oil jet impingement depth at the optimum velocity is given by the following equation.

$$d_1 = 1/P_d = a \quad V_j = \omega_g R \sec \beta \quad (6)$$

When into mesh lubrication is used with high speed gears care must be taken to avoid excessive oil being trapped in the gear teeth. This trapping can cause various problems such as loss of efficiencies, high loads on the teeth, high noise, and even gear failure under some conditions. In many cases the bulk of the cooling oil is supplied to the out of mesh location with only a small percentage for lubrication supplied to the into mesh position reference 14. However, there is usually sufficient oil film remaining on the gear tooth for good lubrication when adequate cooling is provided at the out of mesh location. In some cases where it is difficult to keep the oil out of the into-mesh zone, a circumferential groove will be cut into the center of one of the gears to break up the length of the teeth; thereby, reducing the trapping losses. This groove reduces the axial length required to pump the oil by at least one-half.

RADIAL JET LUBRICATION

When the oil jet is directed radially inward the best impingement depth is obtained. Since gear tooth cooling is a maximum when the oil jet impinges on the face of the tooth, the radial oil jet offers the best method of gear lubrication and cooling. Figure 10 is a high speed photograph of the radial directed oil jet and shows the oil jet penetrating the tooth space just before impingement on the gear tooth flank. The oil pressure here is sufficient to allow the oil jet to impinge on the gear tooth a little more than half way down the working depth of the gear tooth. The maximum cooling is obtained when the oil pressure is sufficient to cause the oil jet to reach an impingement depth equal to the full working depth of the tooth. However adequate cooling can often be obtained with impingement depth just below the pitch line. When radial jet lubrication is used the oil jet should be located near the out of mesh position with the jet directed radially at the center of the gear and pinion. In a speed reducer the pinion will receive cooling on the loaded side

of the tooth while the gear will be cooled on the backface of the tooth. When the gear set is a speed increaser, the pinion will receive cooling on the backface of the tooth and the gear on the loaded side. Experiments have shown (ref. 9) that good cooling of the gear or pinion can be obtained when either the loaded flank or unloaded flank of the gear tooth is cooled. Figure 11 shows the effect of oil jet pressure and load on gear tooth temperature using radial oil jet cooling on the back flank of the gear tooth. The temperature was measured on the loaded flank of the gear tooth. This figure very clearly shows that good cooling is obtained when cooling the back flank of the tooth.

The following equations from references 9 and 15 gives the impingement depth on the tooth flank for various speeds and oil jet pressures for a radial directed oil jet.

$$d_i = \frac{1.5708 + 2 \tan \phi + B/2}{P_d \left(\frac{N_d}{2977 \sqrt{\Delta p}} + \tan \phi \right)} \quad (7)$$

The vectorial model used to calculate the radial impingement depth is shown in figure 12. The analysis and experimental results for a radial directed oil jet are shown in figure 13. When the impingement depth for a given gear operating condition is known or desired then the pressure required to obtain that impingement depth is given by the following equation.

$$\Delta p = \left[\frac{d_i P_d N_d}{2977 \left[\frac{\pi}{2} + \frac{B}{2} + (2 - d_i P_d) \tan \phi \right]} \right]^2 \quad (8)$$

When the oil jet velocity equals the gear velocity the oil jet will usually impinge to a depth approximately equal to the full working depth and provide very good cooling for the gear teeth. For standard gear tooth geometry the pressure required to obtain this velocity may be approximated by the following equation where V is the m/sec (ft/sec) and Δp is in N/cm^2 (psi)

$$\Delta p = V_g^2 / 169 \quad \text{English}$$

$$\Delta p = V_g^2 / 22.8 \quad \text{Metric} \quad (9)$$

Using the above equation for gear operating at a pitch line velocity of 150 m/s (500 ft/s) the oil jet pressure required for full depth impingement would be approximately 1014 N/cm² (1480 psi). This pressure is much higher than the oil jet pressure used in most high speed gear boxes operating at 150 to 300 m/s (500 to 1000 ft/s). These gear boxes must operate at reduced loads because for the limited cooling available. It should be understood that the oil jet size must be reduced at these high pressures to limit the oil flow to that required for good cooling. Using the minimum orifice size of 1.02 mm (0.04 in) specified by many gear designs would give an oil flow of approximately 1.3 gpm per orifice which may be too much oil for most applications. However if the orifice size is reduced to 0.5 mm (0.02 in) then the oil flow is only 0.33 gpm or 1/4 of that for the larger orifice. In order to limit orifice plugging the oil should be filtered through a 5 or 10 μm filter. It is much better for both the gears and bearings to filter the oil through a 5 μm or better filter. The finer filtration will also improve the gear and bearing life.

COOLING REQUIREMENTS

This amount of lubricating fluid required for cooling of gears and bearings may be determined by estimating the power loss for gears, bearings etc., and then using an appropriate temperature rise in the oil, the required oil flow can be determined. The following equation can be used to determine the oil flow in a given gear system. Assume 2000 hp is transmitted in a gear set with one mesh and two sets of bearings. The losses per mesh in a well designed spur or helical gearbox should be no more than 0.5 percent with the losses

equally divided between the gears and bearings. The oil therefore must absorb 0.005×2000 or 10 hp, which is 424.4 Btu/min. Assuming a 50 °F temperature rise, the total oil flow required would be,

$$w = \frac{Q}{c_p \Delta T} = \frac{424.4}{0.6 \times 50} = 14.2 \text{ lb/min} \quad (10)$$

with equal flow to the gears and bearings of 7.1 lb/min. If the gear set is less efficient than the above then more oil flow would be required.

SUMMARY AND CONCLUSIONS

There are several types of losses in gearbox systems that should be evaluated in a high speed gear design. These losses include the gear tooth sliding and friction, the windage of the air flowing around the gears, the churning losses of the oil being pumped or accelerated by the gears and the bearing losses of rolling element or fluid film bearings. Good design practices can reduce the effect of these losses.

The gears may be lubricated by one or more of several methods. For high speed gears the pressure oil jet is definitely required to provide good cooling. Oil jets may be directed into mesh, out of mesh, or in a radial direction at various oil jet pressures. However, for the maximum cooling and lubrication of the gear set the oil jet should be directed radially at the gear and pinion near the out of mesh position. This will provide good cooling and lubrication and keep the oil from entering into mesh zone where excessive losses may occur. The conclusions may be summarized as follows.

(1) Gearbox efficiency for high speed gearing can be improved by careful attention to reducing windage and churning losses.

(2) The best method for lubrication and cooling of high speed gearing is a high pressure oil jet at the out of mesh position directed radially at the gear and pinion with sufficient velocity or pressure to impinge on the tooth flank well below the pitch line.

(3) When the above conditions are performed, high speed gears can operate at considerable higher power levels than the majority of high speed gearboxes are operating at today.

REFERENCES

1. Dudley, Darle W.: Characteristics of Regimes of Gear Lubrication. International Symposium on Gearing and Power Transmissions, Aug. 30-Sept. 3, 1981, Tokyo, Japan, vol. 1, pp. 319-324.
2. Townsend, Dennis P.: The Application of Elastohydrodynamic Lubrication in Gear Tooth Contacts. NASA TM-X-68142, 1972.
3. Townsend, Dennis P.; Baber, Berl B.; and Nagy, Andrew: Evaluation of High Contact Ratio Spur Gears With Profile Modification, NASA TP-1458, 1979.
4. Fuller, Dudley, D.: Theory and Practice of Lubrication for Engineers. Wiley, 1965.
5. Harris, Tedric A.: Rolling Bearing Analysis. Wiley, 1966.
6. Pirvics, Juris; and Klechner, Robert J.: Prediction of Ball and Roller Bearing Thermal and Kinematic Performance by Computer Analysis. Advanced Power Transmission Technology, NASA CP-2210, G.K. Fischer, ed., 1983, pp. 185-201.
7. Coe, Harold H.: Predicted and Experimental Performance of Large-Bore High-Speed Ball and Roller Bearings. Advanced Power Transmission Technology, NASA CP-2216, G.K. Fischer, ed., 1983, pp. 203-220.
8. Dawson, F.H.: Windage Loss in Large High-Speed Gears. Proceedings of the Institution of Mechanical Engineers, Part A - Power and Process Engineering, vol. 198A, no. 1, 1984, pp. 51-59.
9. Townsend, D.; and Akin, L.: Analytical and Experimental Spur Gear Tooth Temperature as Affected by Operating Variables. J. Mech. Des., vol. 103, no. 1, Jan. 1981, pp. 219-226.

10. Townsend, D.P.; and Akin, L.S.: Study of Lubricant Jet Flow Phenomena in Spur Gears - Out of Mesh Condition. J. Mech. Des., vol. 100, no. 1., Jan. 1978, pp. 61-68.
11. Akin, L.S.; and Townsend, D.P.: Lubrication Jet Flow Phenomena in Spur and Helical Gears with Modified Center Distances and/or Addendums. For Out-of-Mesh Conditions. Journal of Mechanisms, Transmissions, and Automation in Design, vol. 107 no. 1, Mar. 1985, pp. 24-30.
12. Akin, L.S.; and Townsend, D.P.: Into Mesh Lubrication of Spur Gears with Arbitrary Offset Oil Jet. Part I - For Jet Velocity Less Than or Equal To Gear Velocity. Journal of Mechanisms, Transmissions and Automation in Design, vol. 105, no. 4., Dec. 1983, pp. 713-178.
13. Akin, L.S.; and Townsend, D.P.: "Into Mesh Lubrication of Spur Gears with Arbitrary Offset Oil Jet. Part II - For Jet Velocities Equal to or Greater Than Gear Velocity. Journal of Mechanisms, Transmissions and Automation in Design, vol. 105, no. 4., Dec. 1983, pp. 719-724.
14. Tucker, A.I.: Bevel Gears at 203 m/s (40,000 FPM). ASME Paper 77-DET-178, Sept. 1977.
15. Akin, L.S.; Townsend, D.P., and Moss, J.J.: Study of Lubricant Jet Flow Phenomena in Spur Gears. J. Lubr. Technol., vol. 97, no. 2, Apr. 1975, pp. 283-288.

ORIGINAL PAGE IS
OF POOR QUALITY

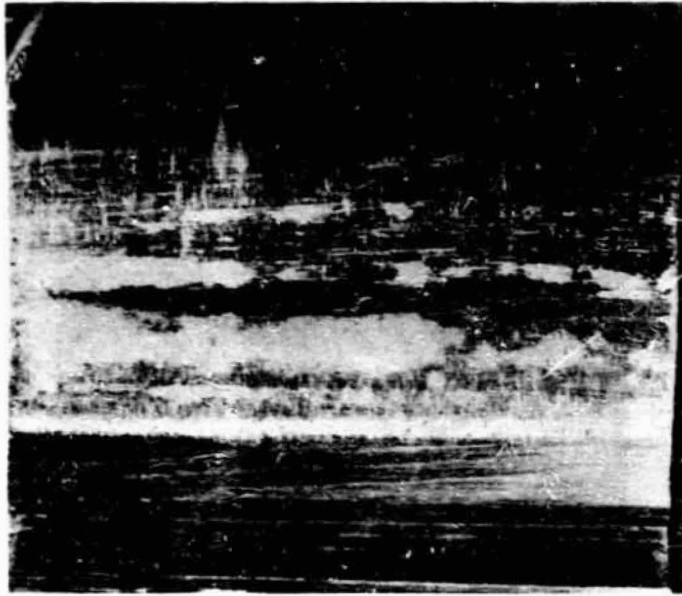

(a) Spur, 60 HRC.

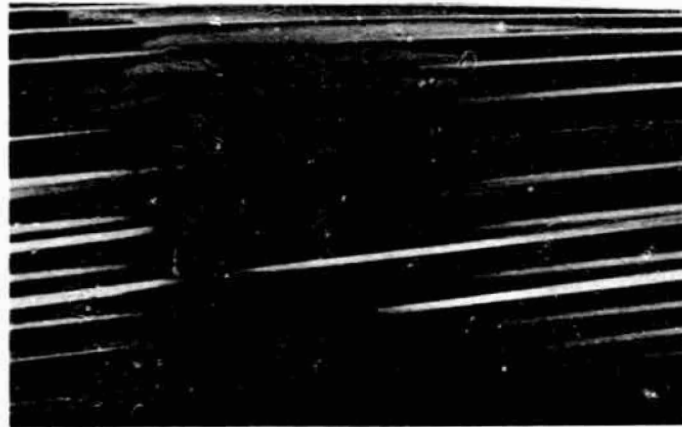

(b) Helical, 60 HRC.

Figure 1. - Examples of micro pitting.

ORIGINAL PAGE IS
OF POOR QUALITY

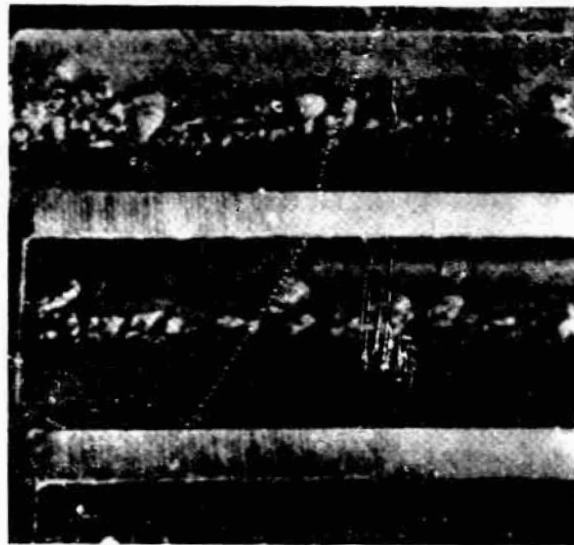
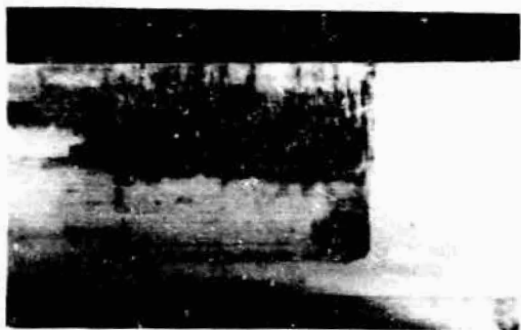

Figure 2. - Destructive pitting: Heavy pitting has taken place, predominantly in the dedendum region (ref. 2).



(a) Standard gear.



(b) New-tooth-for-mi gear.

Figure 3. - Typical scoring failures.

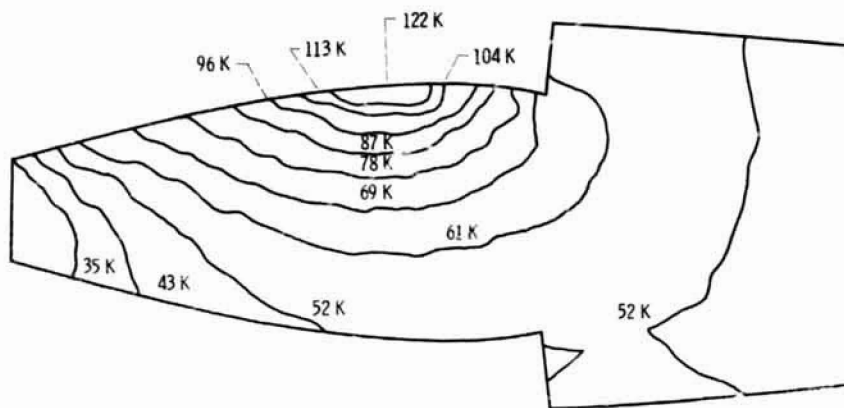

(a) Zero impingement depth.

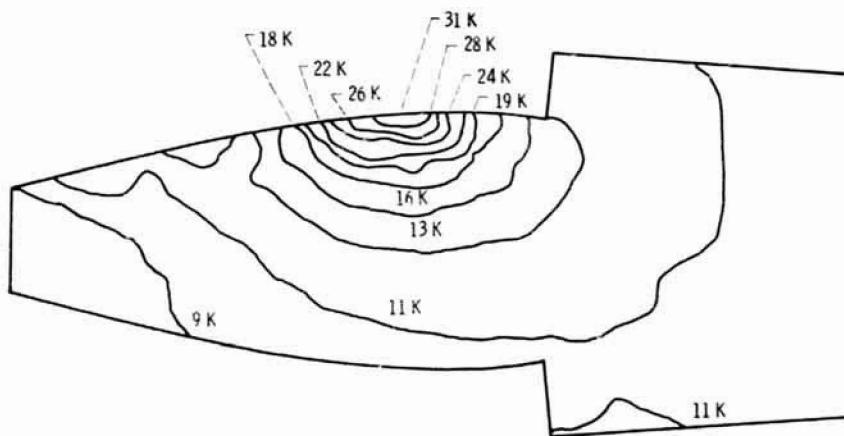

(b) 87.5 percent Impingement depth.

Figure 4. - Calculated gear tooth temperatures speed 10 000 rpm, load 5903 N/cm (3373 lb/in).

ORIGINAL PAGE IS
OF POOR QUALITY

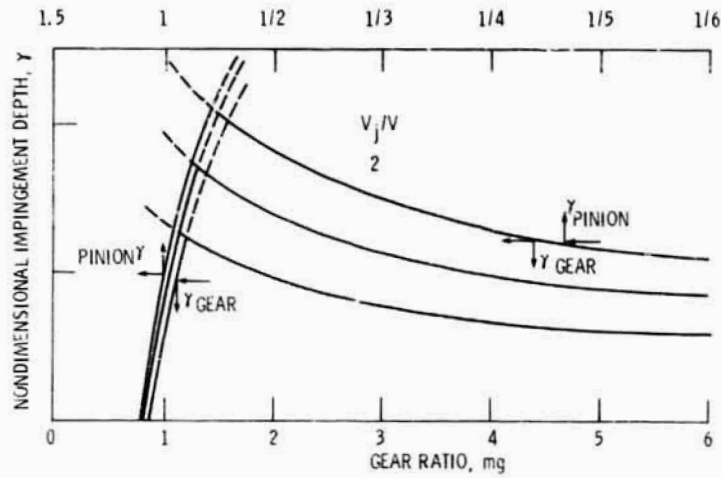

Figure 5. - Gear ratio vs nondimensional impingement depth speed 3600 rpm jet pressure $17 \times 10^4 \text{ N/m}^2$ (25 psi) 28 pinion teeth.



(a) Oil jet clearing pinion teeth.



(b) Oil jet clearing gear teeth.

Figure 6. - Oil jet impingement depth, out of mesh. Speed, 3600 rpm; jet pressure, $8.3 \times 10^4 \text{ N/m}^2$ (12 psi).

ORIGINAL PAGE IS
OF POOR QUALITY

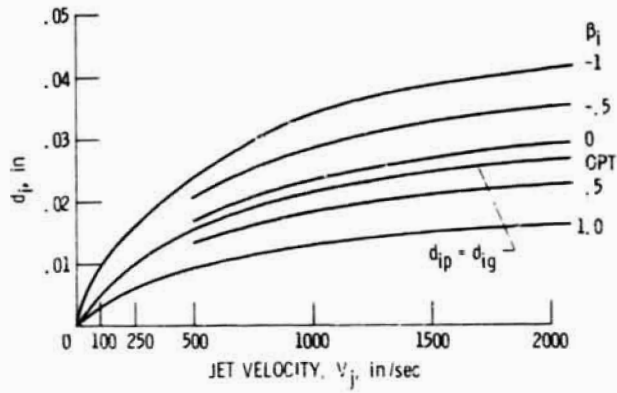

Figure 7. - Effect of β_i on impingement depth, $S_i = 1.0$,
21/35 gear ratio.



Figure 8. - Into mesh lubrication for $V_j > V_g$

ORIGINAL PAGE IS
OF POOR QUALITY

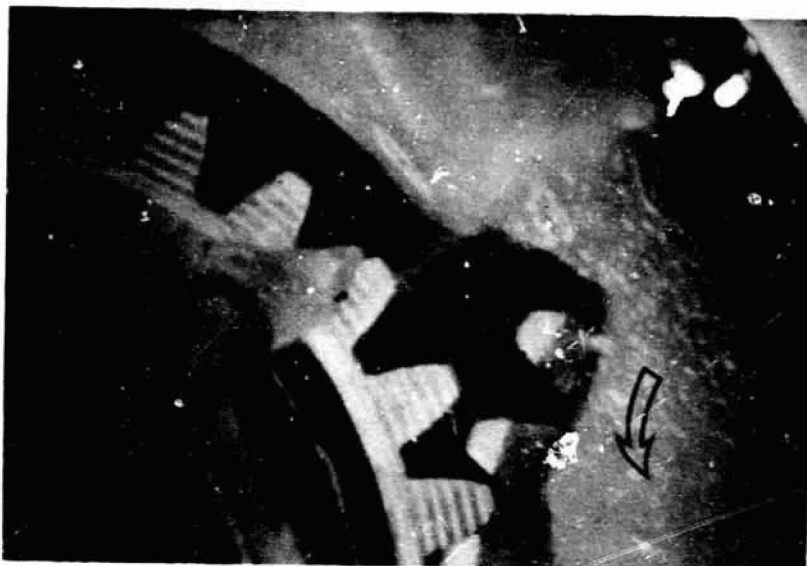

Figure 9. - into mesh lubrication for $V_j > V_g$.



Figure 10. - Radial jet lubrication 5000 RPM oil jet pressure 21N/cm^2 30 PSI.

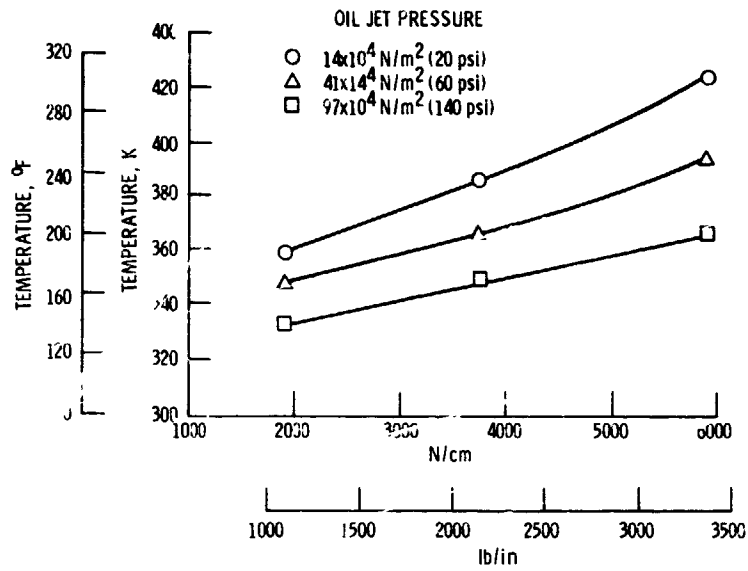

Figure 11. - I. R. microscope measurement of gear average surface temperature vs load for three oil jet pressures, speed 7500 r.p.m., oil jet diameter 0.04 cm (0.016 in) inlet oil temperature 308 K (95 °F).

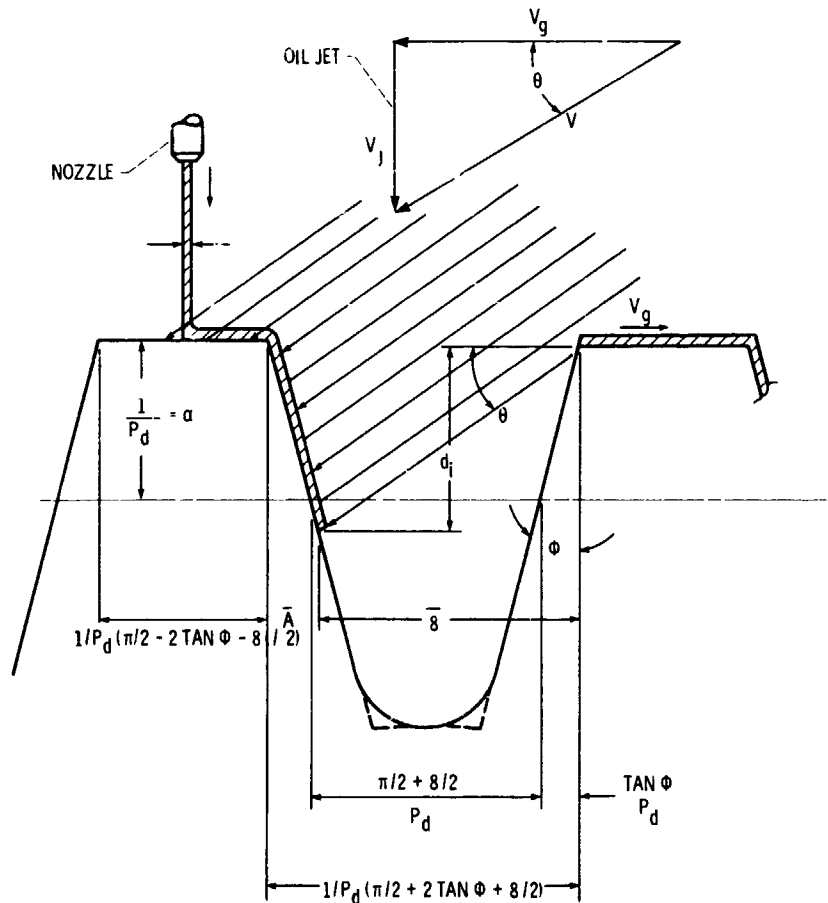

Figure 12. - Vectorial model for penetration depth.

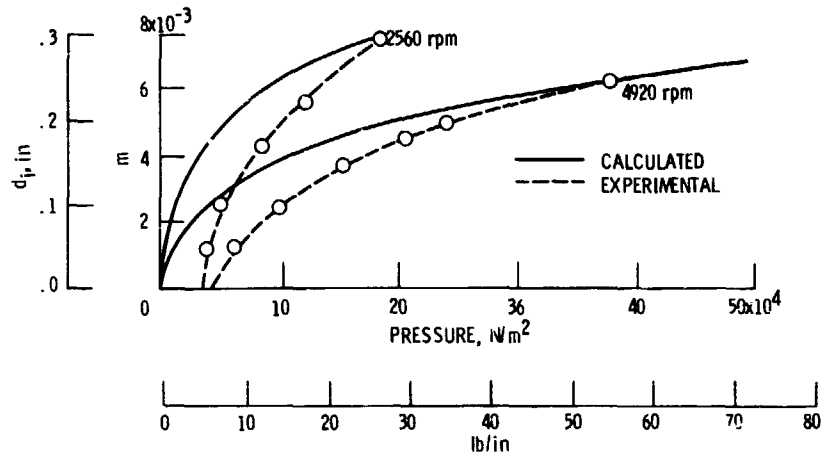

Figure 13. - Calculated and experimental impingement depth vs oil jet pressure at 4920 and 2560 rpm.

1. Report No. NASA TM-87096		2. Government Accession No.		3. Recipient's Catalog No.	
4. Title and Subtitle Lubrication and Cooling for High Speed Gears				5. Report Date	
				6. Performing Organization Code 505-42 94	
7. Author(s) Dennis P. Townsend				8. Performing Organization Report No. E-2660	
				10. Work Unit No.	
9. Performing Organization Name and Address National Aeronautics and Space Administration Lewis Research Center Cleveland, Ohio 44135				11. Contract or Grant No.	
				13. Type of Report and Period Covered Technical Memorandum	
12. Sponsoring Agency Name and Address National Aeronautics and Space Administration Washington, D.C. 20546				14. Sponsoring Agency Code	
15. Supplementary Notes Prepared for the Lubrication Session of the Original Equipment Manufacturing Design Conference, Philadelphia, Pennsylvania, September 9-11, 1985.					
16. Abstract <p>The problems and failures occurring with the operation of high speed gears are discussed. The gearing losses associated with high speed gearing such as tooth mesh friction, bearing friction, churning, and windage are discussed with various ways shown to help reduce these losses and thereby improve efficiency. Several different methods of oil jet lubrication for high speed gearing are given such as into mesh, cut of mesh, and radial jet lubrication. The experiments and analytical results for the various methods of oil jet lubrication are shown with the strengths and weaknesses of each method discussed. The analytical and experimental results of gear lubrication and cooling at various test conditions are presented. These results show the very definite need of improved methods of gear cooling at high speed and high load conditions.</p>					
17. Key Words (Suggested by Author(s)) Gears; Lubrication; High speed gears; Cooling; Friction; Efficiency			18. Distribution Statement Unclassified - unlimited STAR Category 37		
19. Security Classif. (of this report) Unclassified		20. Security Classif. (of this page) Unclassified		21. No. of pages	22. Price*