

NASA TM-77912

NASA TECHNICAL MEMORANDUM

NASA TM-77912

SUPERSONIC FLOW WITH FEEDING OF ENERGY

W. Zaremba

NASA-TM-77912 19850026850

Translation of "Przepływ naddźwiękowy z doprowadzeniem energii,"
Technika Lotnicza i Astronautyczna, Vol. 30, February, 1975, pp.
13-16 (A75-24826)

Library of Congress

SEP 10 1985

LANGLEY RESEARCH CENTER
1111 POWERLINE RD
HAMPSHIRE, VIRGINIA

NATIONAL AERONAUTICS AND SPACE ADMINISTRATION
WASHINGTON, DC 20546
AUGUST 1985

DISPLAY NASA-TM-77912
SET NUMBER NOT FOUND OR INVALID ACCESSION NUMBER

3 1 1 RN/NASA-TM-77912

DISPLAY 03/2/1

85N35163** ISSUE 24 PAGE 4061 CATEGORY 2 RPT#: NASA-TM-77912 NAS
1.15:77912 CNT#: NASW-4006 85/08/00 12 PAGES UNCLASSIFIED DOCUMENT
Original language document was announced in IAA as A75-24826

UTTL: Supersonic flow with feeding of energy

AUTH: A/ZAREMBA, W.

CORP: National Aeronautics and Space Administration, Washington, D.C.

AVAIL NTIS

SAP: HC A02/MF A01

CIO: POLAND Transl. by The Corporate Word, Inc., Pittsburgh, Pa. Transl. into
ENGLISH from Tech. Lotnicza i Astronautyczna (Poland), v. 30, Feb. 1975 p
13-16

MAJS: /*ELECTROMECHANICS/*SHOCK WAVE ATTENUATION/*SUPERSONIC FLOW/*SUPERSONIC
WIND TUNNELS

MINS: / ELECTRODES/ ENERGY CONVERSION EFFICIENCY/ SHOCK TUNNELS/ WEDGE FLOW/
WIND TUNNEL TESTS

ABA: P. T. H.

ABS: The present work discusses the results of some experimental studies on the
possibility of attenuating shock waves in a supersonic flow. The shock
waves were formed by an external source of electrical energy. An
electromechanical method is described that permits partial recovery of the
expended energy.

ENTER: SELECT E10

NASA-TM-77912

1985

SUPERSONIC FLOW WITH FEEDING OF ENERGY. (Przeplw
Naddźwiękowy z Doprowadzeniem Energii). W. Zaremba.
Aug.1985. 12p. (Eng. trans. of Russian article).

Technika Lotnicza i
Astronautyczna, v.30,
p.13-16 (USSR)

Feb.
1975

A75-24826 (Original)
N85-35163#
N-155,617

1. Report No. NASA TM-77912	2. Government Accession No.	3. Recipient's Catalog No.	
4. Title and Subtitle SUPERSONIC FLOW WITH FEEDING OF ENERGY		5. Report Date August 1985	6. Performing Organization Code
		8. Performing Organization Report No.	10. Work Unit No.
7. Author(s) W. Zaremba		11. Contract or Grant No. NASW-4006	
		13. Type of Report and Period Covered Translation	
9. Performing Organization Name and Address The Corporate Word, Inc. 1102 Arrott Bldg. Pittsburgh, PA 15222		14. Sponsoring Agency Code	
		12. Sponsoring Agency Name and Address National Aeronautics and Space Administration Washington, DC 20546	
15. Supplementary Notes Translation of "Przepływ naddźwiękowy z doprowadzeniem energii," <u>Technika Lotnicza i Astronautyczna</u> , Vol. 30, February, 1975, pp. 13-16 (A75-24826).			
16. Abstract This work discusses the results of some experimental studies on the possibility of attenuating shock waves in a supersonic flow. The shock waves were formed by an external source of electrical energy. An electromechanical method is described that permits partial recovery of the expended energy.			
17. Key Words (Selected by Author(s))		18. Distribution Statement Unlimited	
19. Security Classif. (of this report) Unclassified	20. Security Classif. (of this page) Unclassified	21. No. of Pages 12	22. Price

SUPERSONIC FLOW WITH FEEDING OF ENERGY

W. Zaremba

The phenomenon of supersonic flow with feeding of energy /13* is a field in which practical demands have outpaced the scientific base.

The need to control flight at supersonic speeds has forced engineers to rely on experimentation. One experimentally ascertained property of supersonic flow is the shock wave. To date it has not been proven that such a wave must accompany supersonic flow; in all known experiments, however, such a wave has always appeared.

Technological progress has occasioned flow studies in two separate areas. One involves research of flows at a constant speed without feeding of external energy (zero accelerations and energy supply to the system). The other concerns explosions and the concomitant flow of gas (huge accelerations and energy supply).

The present work describes studies attempting to form a shock wave by feeding external energy to the flow (active as opposed to passive systems); it describes in detail results of experimental studies attempting to attenuate shock waves in a supersonic flow.

Studies in this field achieving positive results would lead in practice to an attenuation of the sonic boom produced by supersonic commercial aircraft and furthermore to improved performances by these aircraft.

*Numbers in the margin indicate pagination in the foreign text.

Adding energy ultimately causes formation of pressure in the passive system. Energy can be introduced in various forms: mechanical, thermal, or electrical (the latter partially converts to thermal). In the experiments described, electrical energy was fed to the supersonic flow; hence the name of the field: electro-aerodynamics.

The basis of electro-aerodynamics is relatively simple. If a metallic aircraft is charged with the same value as the molecules of the surrounding atmosphere, those molecules will be repelled both by each other and by the aircraft's electrical field. The atmospheric molecules thus charged in a supersonic flow can emit a signal causing a change in the flow.

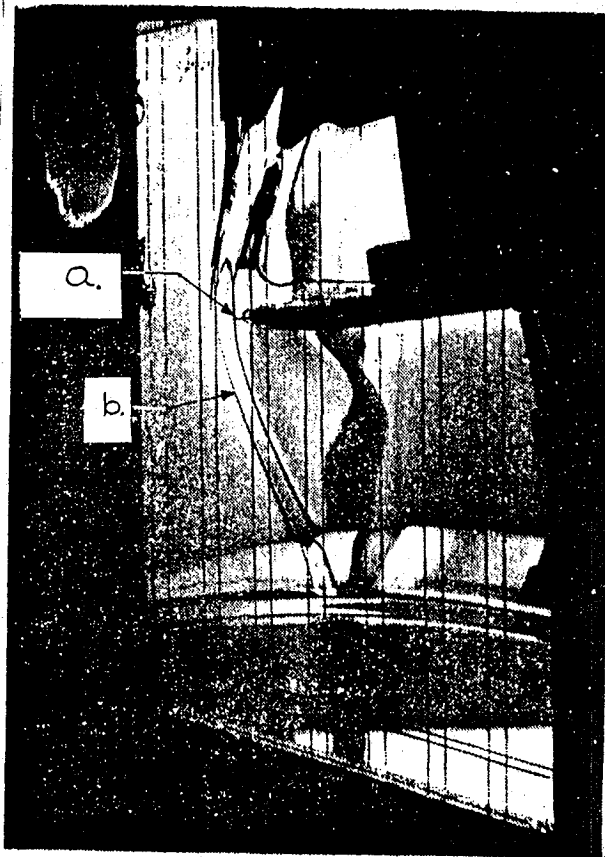

1. Surface waves without voltage. a. Negative electrode; b. Wave

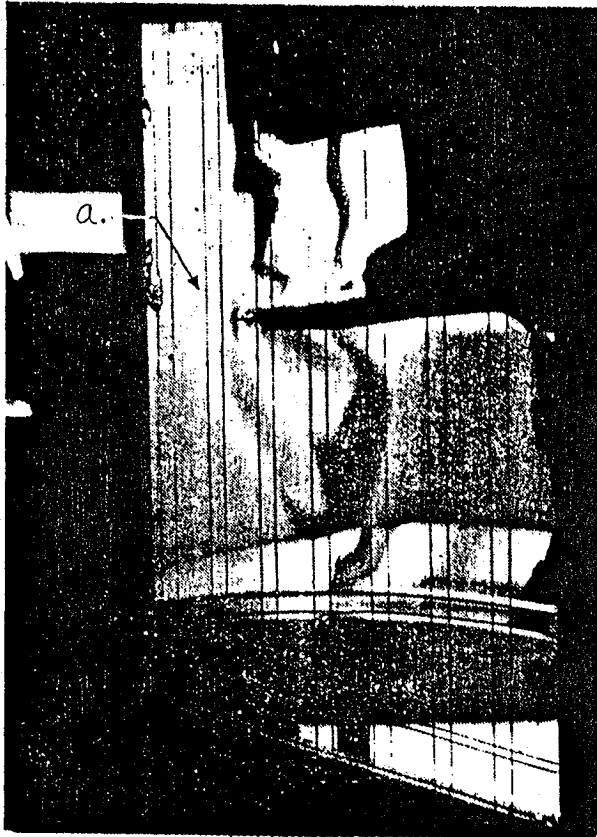

2. Surface waves, same conditions, at 60,000 volts. a. Isolated wave.

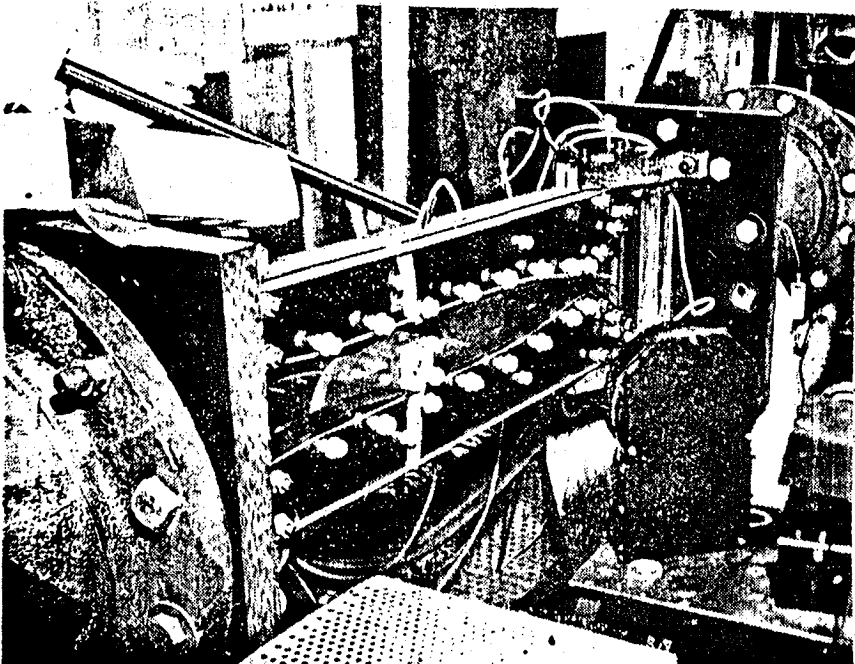

3. Wind tunnel, Mach = 3.

Because an electrical corona propagates at a speed much /14
greater than that of sound, the production of a signal with
sufficient intensity requires a strong electrostatic field
(perhaps millions of volts) and a method for charging the
atmosphere at long distances in advance of the aircraft.

Due to financial constraints, the introductory experiments
were performed in a circular centrifuge tank filled with fluid.
Surface waves observed were analogous to waves arising during
flight.

Illustrations 1 and 2 show the change in wave shape when
66,000 volts are present in the flow. In these experiments a
flat plate with a sharp leading edge was used as a model, while
the electrodes were needles mounted on the leading and trailing
edges. Under voltage (illustration 2) the wave was plainly
forced forward. Measurements indicated an attenuation of /15
wave intensity.

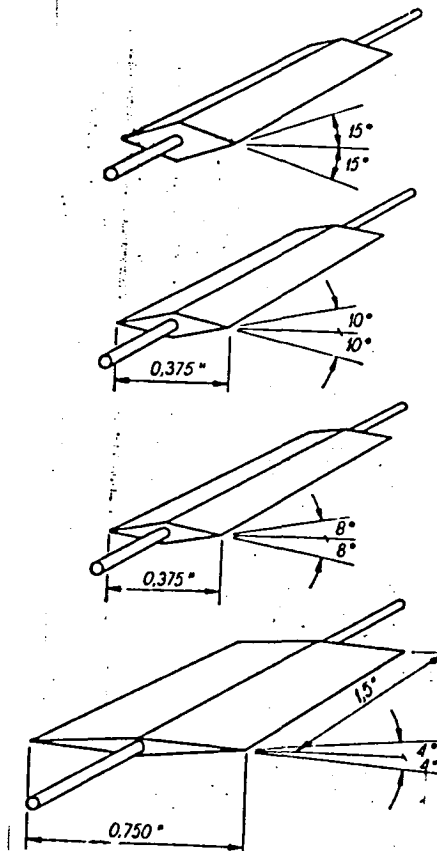

4. Double-wedged model.

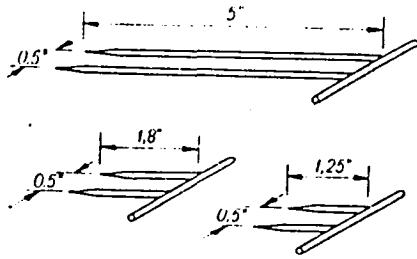

5. Electrode types.

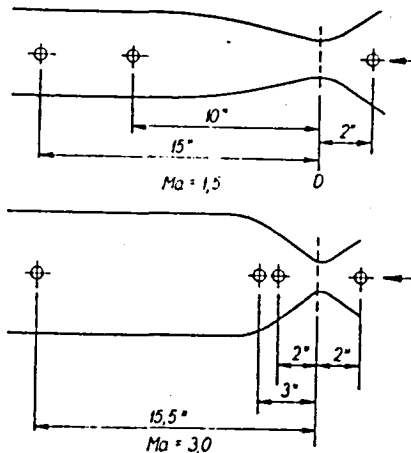

6. Cross-section of tunnel and placement of model and electrodes.

In a subsequent experiment, a sharp cone was mounted in a wind tunnel; a coronal discharge extending far upstream to the front of the tunnel appeared at high voltage.

The aerodynamic experiments described above were presented by Professor G. A. Mokrzycki at a scientific congress in the United States in 1968 and aroused considerable interest.

The experiments were described in the professional press and even in newspapers and periodicals of many countries. One fortunate result was that funding was found for the continuation of the experiments, albeit still on a small scale.

Two small plastic tunnels were built: one for a speed of $Ma = 1.5$, the second for $Ma = 3$, with measurements of 3 X 1.5 inches. The second of these tunnels is shown in illustration 3. To make the flow visible a 5-inch Schlieren apparatus was used with a monitor. The pictures were taken by a fixed camera and a movie camera using 16 mm film.

The models were two-dimensional (illustration 4) and tunnel walls were reinforced. Illustration 5 shows the electrode types; illustration 6, a cross-section of the tunnel and the placement of the model and electrodes.

A double-wedged model with a 10° slope was placed in a stream $Ma = 1.8$. Under a current of 42,000 volts and 1.9 milliamperes a corona was obtained unlike that obtained in a still atmosphere. The shock wave moved forward and the Mach line angle increased, indicating an attenuation of the wave. The pictures were similar to those described above. Wave strength was defined by measuring three double-wedged models with angles of 8, 10, and 15 degrees.

Parenthetically, the electrostatic repulsion of the charged molecules changes the pressure in the flow, and the charged corona glows (is hot). Thus thermal energy is also added to the flow.

Illustration 7 shows wave displacement as a function of pressure, using a model with a 15° slope.

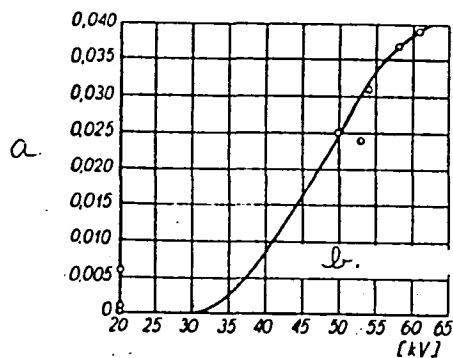

7. Wave displacement under pressure. a. Wave displacement (inches)
b. Model with 15° slope

Under a flow of $Ma = 1.4$ and using a model with 8° slope, the wave presented in illustration 8 was obtained. The Mach lines are here nearly perpendicular to the flow stream. However, when a current of 70,000 volts and 0.01 amperes was fed

into the system, the shock wave disappeared completely from the field of view ($Ma = 1.4$, illustration 9). Only a wattage of 0.7 watts evoked this effect.

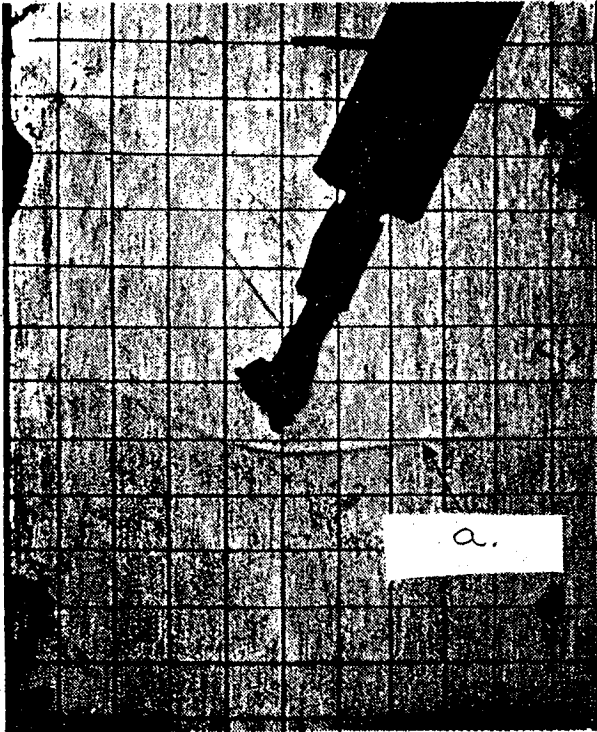

8. Tunnel with a flow $Ma = 1.4$, without electrical pressure. a. Shock wave.

This experiment was repeated several times, always with the same result. Thus, for the first time it has been experimentally demonstrated that the shape and strength of the shock wave can be controlled without a change in speed, and at low energy cost.

The experiments described were repeated in a tunnel with a flow of $Ma = 3$. Under these conditions, however, positive results were not obtained. It is supposed that the reason was too low a pressure. Unfortunately, due to financial considerations, it was not possible to introduce a pressure above 100,000 volts, and it may be that 500,000 volts would yield the desired effect.

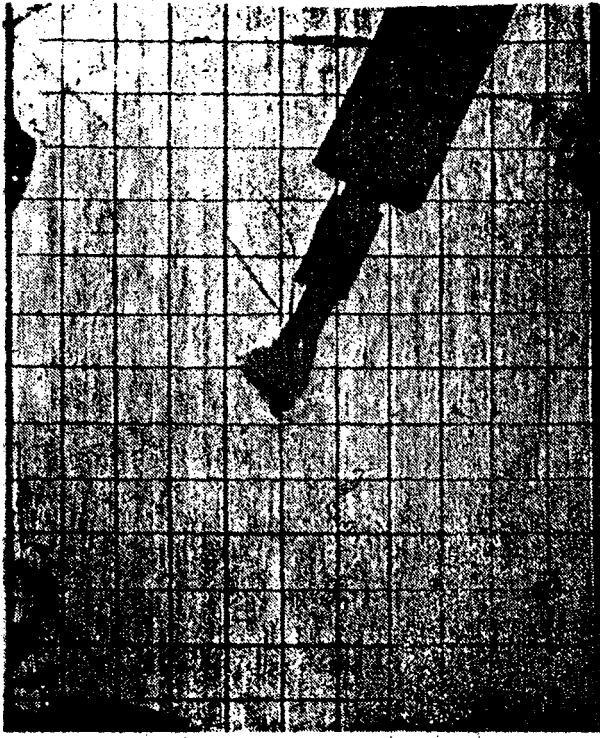

9. Tunnel with a flow $Ma = 1.4$, under a current of 70,000 volts and 0.01 milliamperes (model with 8° slope).

Application of the findings of electro-aerodynamic experiments in attenuating the sonic boom caused by supersonic flights must next be discussed.

/16

The pressure turbulence in the near field (illustration 10) is contained chiefly between the front and rear shock wave. Because overpressures move more quickly and underpressures more slowly than sound, an overpressure tends to move forward, while an underpressure tends to lag behind. As a result, an N-shaped pressure signal ("signature") forms in the far field and two acoustic shocks appear (two sonic booms). It is estimated that for a supersonic transport at a speed of $Ma = 3$, the strength of the shock wave corresponds to a reflected pressure around 0.001 kg/cm^2 (2-4 pounds/square foot), and the time elapsing between the two sonic booms equals 0.4 seconds.

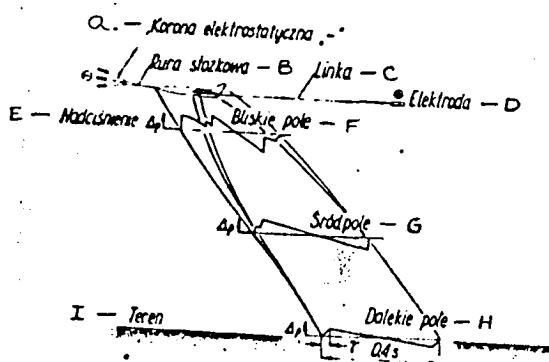

10. Supersonic aircraft pressure signal ("signature").

- a. Electrostatic corona;
- b. Conical pipe;
- c. Cable;
- d. Electrode;
- e. Overpressure;
- f. Near field;
- g. Mid field;
- h. Far field;
- i. Ground

The chief obstacle to the use of supersonic aircraft in commercial flights is acoustic in nature--the blast is unbearable to human beings. Hence the efforts of engineers to diminish the supersonic blast.

The time necessary for the pressure to rise from zero to the maximum is a critical parameter. It is not the intensity of the sound, but its sudden onslaught that is unendurable. An increase in the rise time of only 10 milliseconds causes a noticeable drop in acoustic strength within the range to which the human ear is most sensitive.

A 10-millisecond delay of this nature in the rise time would reduce the supersonic blast to the level of street noise.

Illustration 10 schematically presents the proposed electro-aerodynamic method. A long pipe with a conical tip is secured to the nose of a metallic aircraft fuselage. The fuselage and pipe are under a high negative electrostatic tension, evoking a coronal discharge which imparts a similarly negative charge to the atmospheric molecules.

It is probable that oxygen molecules are instrumental in charging the atmosphere.

The charged molecules will flow along the aircraft in a pattern similar to that for the tunnel described above, attenuating the shock wave and thus reducing the supersonic blast. An insulated antenna (unfolding in flight) ending in a positively charged accumulator is attached to the rear of the fuselage. The negatively charged atmospheric molecules will transfer their charge to the accumulator, thereby returning a portion of the energy expended in creating the corona.

In more recent years in the United States, S. B. Batdorf, following Professor Mokrzycki, announced studies in which he proposes feeding thermal energy into the flow in order to attenuate the supersonic blast. He estimates that to diminish the blast at Mach 3 would require 20% of the aircraft's propulsive power. Another scientist, Sin I-Cheng, recommends feeding mechanical energy to the flow in order to diminish the supersonic blasts and improve aircraft performance. He proposes using an air compressor to blow a stream of air under the aircraft wing.

The electro-aerodynamic method is to date the only one in which a portion of the expended energy is recovered. It is clear however that much research is still necessary before advancing from small-scale laboratory experiments to practical applications in aircraft construction.

LANGLEY RESEARCH CENTER



3 1176 00188 5822