

3 1176 01306 8060

NASA Technical Memorandum 86820

NASA-TM-86820 19850026897

[Faint, illegible handwritten text]

Space Missions for Automation and Robotics Technologies (SMART) Program

Donald L. Ciffone and Henry Lum, Jr.

August 1985

LIBRARY COPY

SEP 30 1985

RESEARCH CENTER
LIBRARY, NASA
WASHINGTON, VIRGINIA

NASA

National Aeronautics and
Space Administration



Space Missions for Automation and Robotics Technologies (SMART) Program

Donald L. Ciffone
Henry Lum, Jr., Ames Research Center, Moffett Field, California

August 1985



National Aeronautics and
Space Administration

Ames Research Center
Moffett Field California 94035

N85-35210 #

Space missions for automation and robotics technologies (SMART) program

Donald L. Ciffone and Henry Lum, Jr.

Information Sciences Office, NASA Ames Research Center
Mail Stop 244-7, Moffett Field, California 94035

Abstract

NASA is currently considering the establishment of a Space Missions for Automation and Robotics Technologies (SMART) Program to define, develop, integrate, test, and operate a spaceborne national research facility for the validation of advanced automation and robotics technologies. Initially, the concept is envisioned to be implemented through a series of Shuttle-based flight experiments which will utilize telepresence technologies and real-time operational concepts. However, eventually the facility will be capable of a more autonomous role and will be supported by either the Shuttle or the Space Station. To ensure incorporation of leading-edge technology in the facility, performance capability will periodically and systematically be upgraded by the solicitation of recommendations from a user advisory group. The facility will be managed by NASA, but will be available to all potential investigators. Experiments for each flight will be selected by a peer review group. Detailed definition and design is proposed to take place during FY 86, with the first SMART flight projected for FY 89. This paper discusses the objectives and rationale for the proposed SMART Program, potential implementation scenarios, and the management approach. The main purpose of the paper is to make the reader aware of this upcoming program, and to encourage participation beginning with the conceptual definition phase.

Introduction

In response to Public Law 98-371, dated July 18, 1984, the NASA Advanced Technology Advisory Committee (ATAC) has studied automation and robotics for use in the Space Station and prepared a report¹ for the House and Senate Committees on Appropriations. The study has drawn from the work by groups both within NASA and outside NASA, and in the academic and industrial communities. Page iii of the Executive Overview (Volume 1) of this report states, "The development of the Space Station offers a chance both to advance the technology of automation and robotics, as proposed by Congress, and to put that technology to use. The use of advanced automation and robotics technology in the Space Station would greatly enhance its capabilities. And the Space Station would thereby provide a logical driving force for a new generation of machine intelligence and robotics technology, built on recent advances in artificial intelligence, robotics, computer science, and microelectronics." The proposed SMART Program is fully responsive to this recommendation as well as to NASA's more generic research and technology objectives and plans "to develop and provide spacecraft technology for advanced spacecraft to support the nation's commercial and scientific objectives in space." The SMART Program will focus the automation and robotics technologies toward space applications, and through evolutionary and systematic development and validation demonstrations, it will stimulate use, build user confidence, and accelerate both technology transfer and incorporation into operational systems. While automation and robotics technologies can be evaluated using ground test facilities, the necessity of technology testing and validating in a realistic space environment is dictated by the constraints imposed by space, such as remoteness, zero gravitation, the generally hostile nature of the space environment, and operation under realistic mission constraints.

Technical Approach

The use of automation in spacecraft is not a new concept, previous and existing space systems utilized it to varying degrees, and Space Station plans have always called for the use of mobile remote manipulators and advanced control devices. However, as the NASA ATAC¹ points out, the demands of a multipurpose facility like the Space Station are so great that major advances into the challenging territory of adaptable and general-purpose automation and robotics should be made if the full potential of the Space Station is to be realized. ATAC¹ strongly recommends that the initial Space Station utilize significant elements of automation and robotics technology and that verification of the performance of automated equipment should be stressed, including terrestrial and space demonstrations to validate technology for Space Station use. Essential to the success of the demonstrations is that testing be done under realistic conditions. This requires that evaluations be conducted with the test item "embedded"; that is, functioning in an environment that resembles the eventual operational environment. Consistent with these recommendations the SMART Program is conceptually envisioned to be a long-life flight test and validation program for automation and robotics technology. It will provide a modularly designed hardware arrangement consisting of sensors, manipulators,

computers, and other subsystems which can be exchanged with new, more advanced subsystems to evolve into a highly capable and autonomous flight test facility.

The detailed definition and design phase of the SMART Program is scheduled to begin in FY 86 after final Program approval. In preparation for this phase of the Program, a SMART workshop is to be held at NASA's Ames Research Center on August 26-27, 1985. Approximately 25 to 30 participants from academia, industry, and the NASA Centers have been invited to attend. The purpose of the workshop is to begin establishing user and technical requirements for the SMART facility and to address related questions, such as

1. What is the expected utility of this kind of facility?
2. What should be the procedures for using the facility?
3. What is required to operate such a facility in space?
4. What impact will this facility have on automation and robotics research and development?

The results of the workshop will be summarized and published in a proceedings. Facility concepts discussed at the workshop will probably center around a Space Shuttle-based facility and will include possibilities such as

1. A robotic system attached to the Shuttle Remote Manipulator System (RMS), Figure 1.
2. A robotic system attached to the Manned Maneuvering Unit (MMU), Figure 2.
3. A robotic system attached to the Orbiting Maneuvering Vehicle (OMV), Figure 3.
4. A self-contained automation and robotics module similar to the concept shown in Figure 4.²

While these concepts will serve as a starting point to acquaint participants with potential possibilities and operational constraints, it should be pointed out that preliminary conversations with industry and academia show distinct advantages for the module approach. An automation and robotics module of this type would be self-contained, need not be pressurized nor manned, and would minimize the interface and interference with Shuttle operators. The module concept also has the potential of being mated with the OMV for orbital mobility and eventual docking and connection with the Space Station, as shown in Figure 5. Shells for such a module may be available from NASA inventory (i.e., Space Lab). The interior architecture could be designed to allow an evolutionary growth in experiment complexity and autonomy from simple robots constrained to rails to free-flying multiple robots working in a controlled, distributed environment toward a common work objective. Within the module, space application demonstrations could include various phases of satellite servicing, space station servicing, in-space assembly and construction, expendables resupply, in-space manufacturing, and monitoring diagnosis. Advanced robotics, automation, and telepresence technologies as well as real-time control and operational concepts would be evaluated. As a minimum an initial experiment might include teleoperation via real-time video feedback of a dual-arm/hand on a nonfree-flying robotic platform with force and contact sensing performing an assembly task. Later experiments could include free-flying robotic platforms with multiple arms, automated planners, and color vision performing assembly, servicing, and fabrication tasks. Total systems could be verified in a space-operational environment prior to technology transfer to Shuttle or Space Station. This approach benefits industry by allowing the test and validation of in-space manufacturing techniques before committing to large investments. Resulting technologies will also be applicable to terrestrial applications. It is planned that all facility experiments will be evaluated prior to flight in NASA ground test facilities such as automation laboratories and the Marshall Space Flight Center's Neutral Buoyancy Facility. This approach will maximize the potential for a successful flight.

The SMART facility will provide the basic hardware and software to accommodate flight investigators. These basics could include, but not be limited to, symbolic and numerical processors, sensors (including vision), interchangeable manipulators and end effectors, a LISP and ADA programming environment, and payload space for demonstration experiments. Operation from a ground control station will be provided to allow validation of the effects of time delay on the operation of an automated facility.

Beginning with the initial flight, emphasis will be given to establishing "robot factor" criteria to organize the robot workspace, and to evaluate and validate "hooks and scars" concepts for the Space Station. Areas of particular interest include automated monitoring of subsystems, change-out of subsystems in a "power-up" environment, and integration of evolving technologies.

In the facility development NASA will utilize and leverage, as much as possible, the automation and robotics research and development programs of other government agencies.

Management Approach

The SMART Program management structure is shown in Figure 6. It is envisioned that the Program will be managed by NASA Ames Research Center. A multicenter NASA team will be established to implement the Program and operate the facility. Center roles are being defined; their involvement is being negotiated to optimize the use of existing resources. NASA Headquarters will assume the responsibility of overall Program management and advocacy. Industry, academia, and other government agencies will be involved with NASA in establishing the facility definition and requirements, as well as in periodic and systematic upgrades of the facility to ensure leading-edge performance capability. This function will be accomplished through a user advisory group which will be chaired by NASA. The composition and numbers of membership of this group have not yet been established. Although the facility will be managed by NASA, it will be open to any potential investigator. A peer review group will be established to select the principal investigators for each flight. It is being considered that this group should consist of four members each from academia and industry and be chaired by NASA. Each member would serve for 2 years, and the terms would be staggered so that there would be a 50% turnover in membership each year. The NASA Chair would be rotated among the participating Centers. Program plans and documentation will be developed and made available to the user community.

The conceptual definition and design phase of the SMART Program will begin during FY 86 after final Program approval. It is anticipated that a flight proposal will be submitted to NASA Headquarters in the spring of 1986 for a first Shuttle-based flight during FY 89.

References

1. NASA Advanced Technology Advisory Committee, "Advancing Automation and Robotics Technology for the Space Station and for the U.S. Economy," NASA TM 87566, Vols. 1 and 2, 1985.
2. General Electric Co., "Automation Requirements Derived From Space Manufacturing Concepts," Space Station Automation Study, Vol 2, 1984.

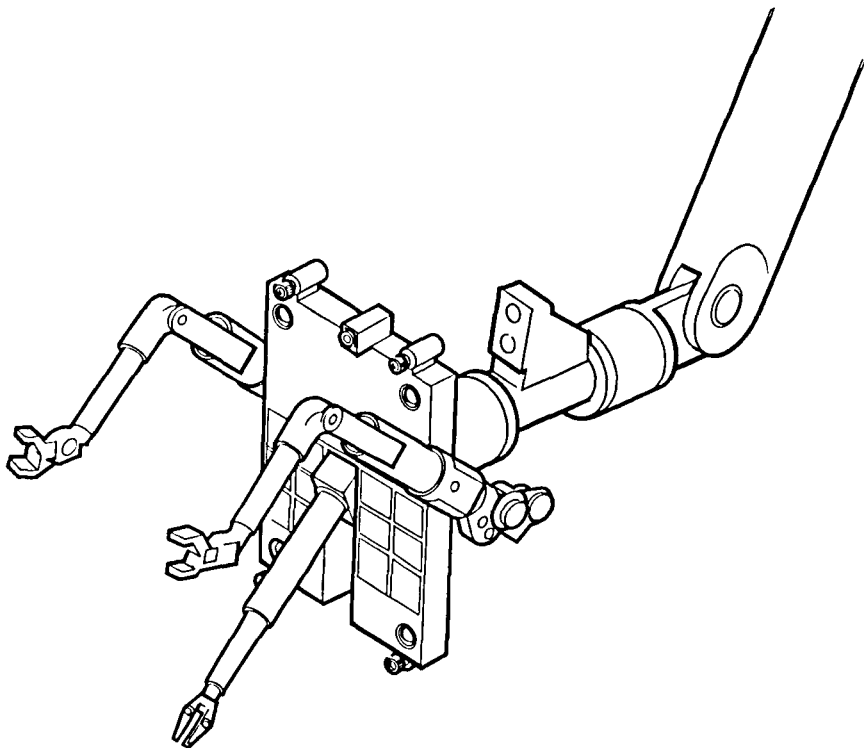

Figure 1. Proposed SMART facility concept: robotic system attached to the Shuttle RMS.

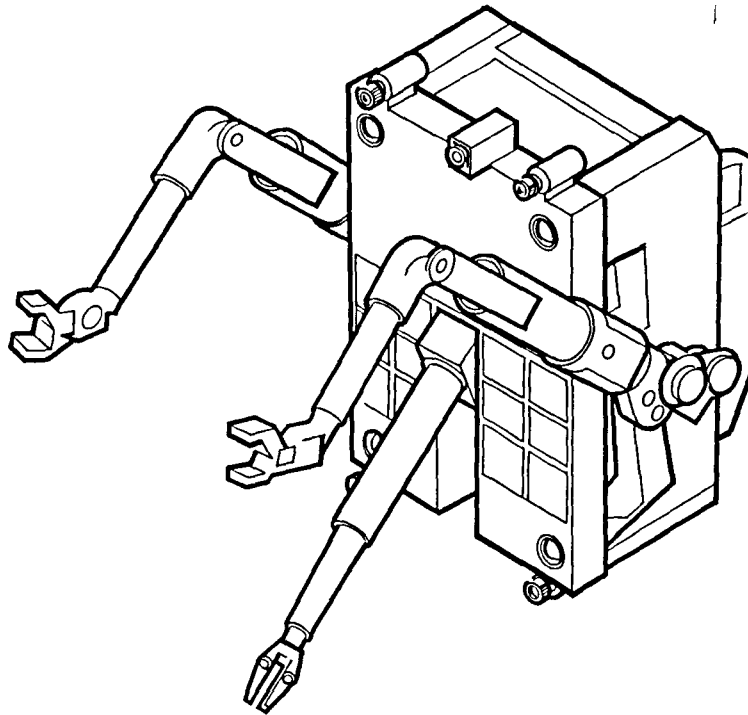

Figure 2. Proposed SMART facility concept: robotic system attached to the MMU.

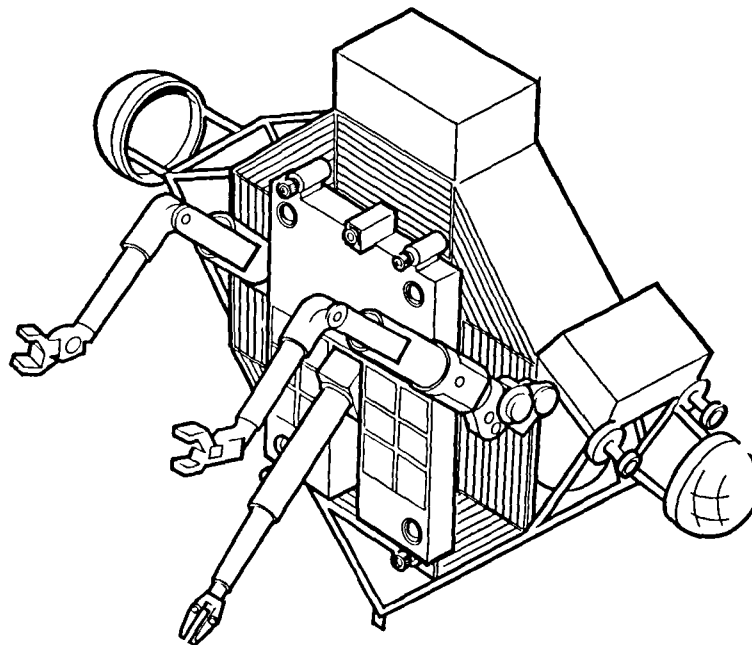

Figure 3. Proposed SMART facility concept: robotic system attached to the OMV.

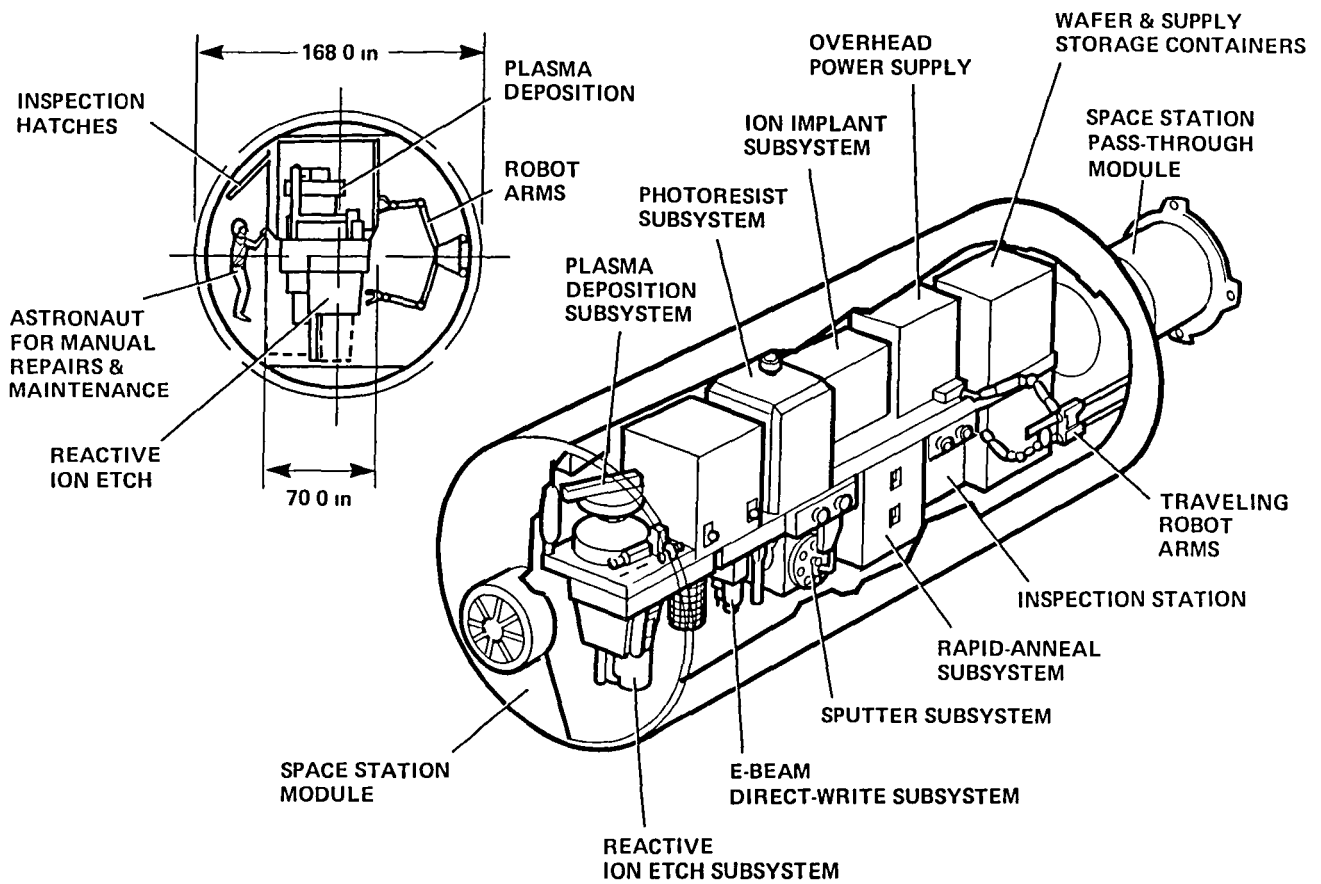

Figure 4. Proposed SMART facility concept: self-contained automation and robotics module

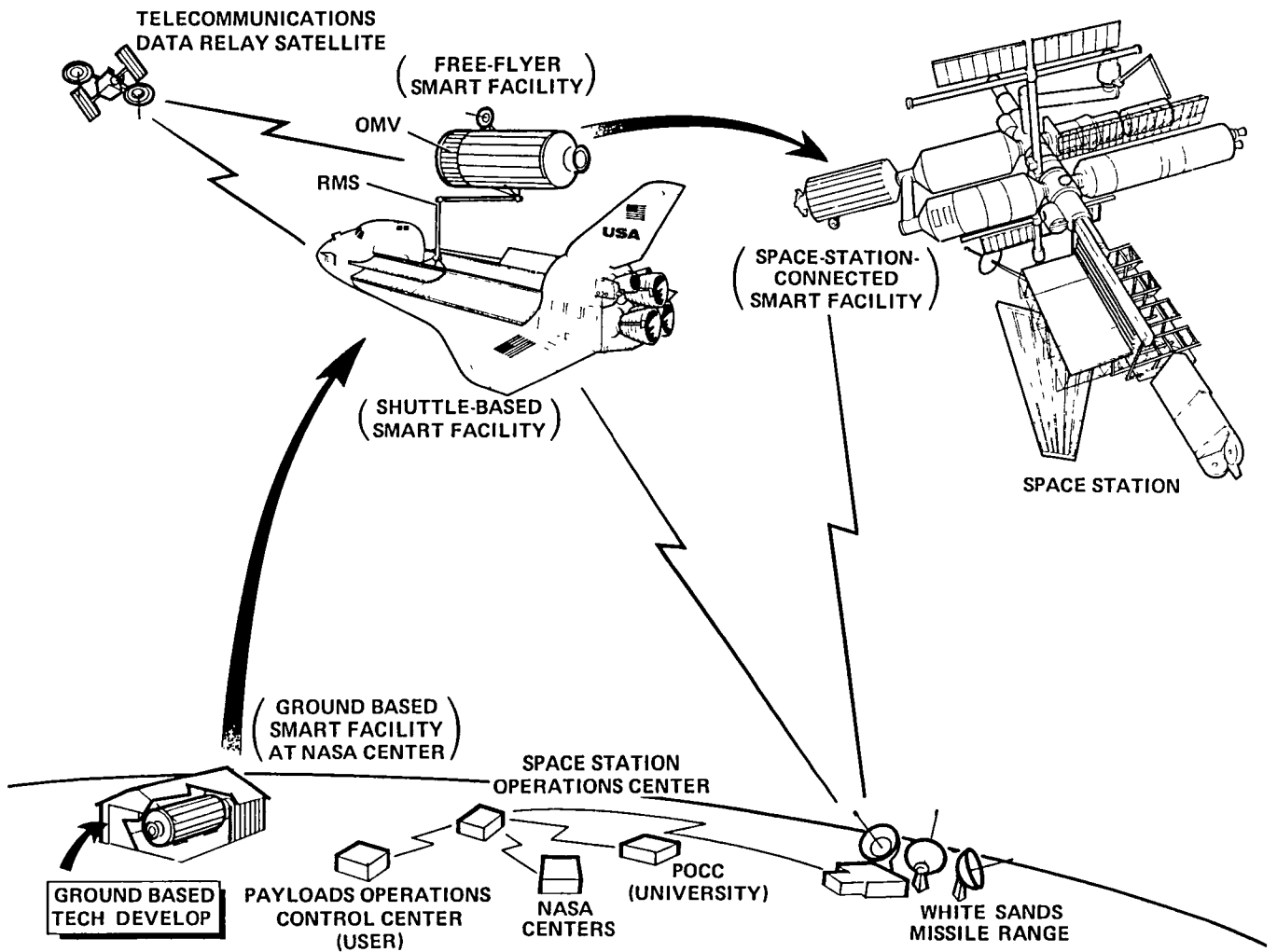

Figure 5. Evolution of the proposed SMART module facility concept.

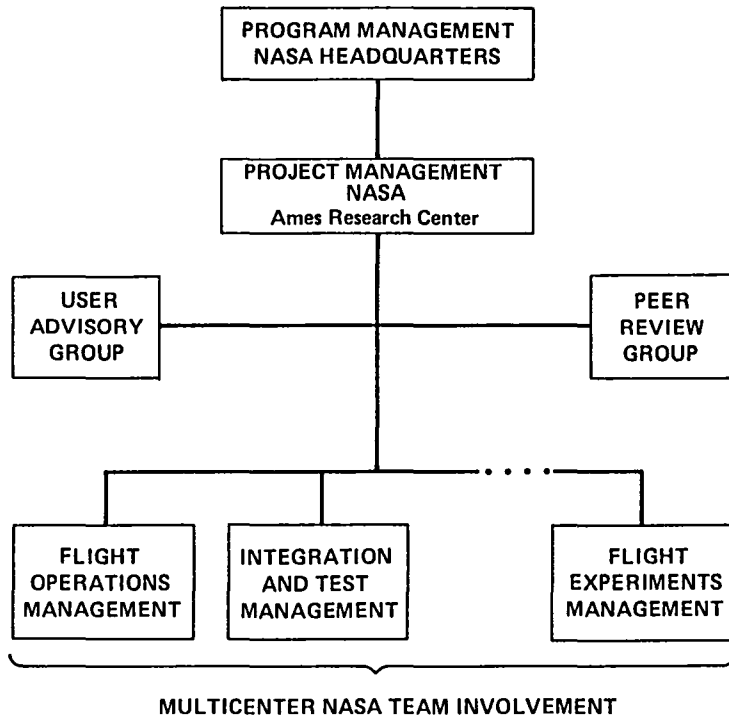

Figure 6. SMART Program management structure.

1 Report No NASA TM-86820	2 Government Accession No	3 Recipient's Catalog No	
4 Title and Subtitle SPACE MISSIONS FOR AUTOMATION AND ROBOTICS TECHNOLOGIES (SMART) PROGRAM		5 Report Date August 1985	6 Performing Organization Code
		8 Performing Organization Report No 85375	10 Work Unit No T-6313
7 Author(s) Donald L. Ciffone and Henry Lum, Jr.		11 Contract or Grant No	
9 Performing Organization Name and Address Ames Research Center Moffett Field, CA 94035		13 Type of Report and Period Covered Technical Memorandum	
		14 Sponsoring Agency Code 506-54-61	
12 Sponsoring Agency Name and Address National Aeronautics and Space Administration Washington, DC 20546		15 Supplementary Notes Point of Contact: Donald L. Ciffone, Ames Research Center, MS 244-7, Moffett Field, CA 94035, (415)694-5699 or FTS 464-5699	
16 Abstract <p>NASA is currently considering the establishment of a Space Mission for Automation and Robotics Technologies (SMART) Program to define, develop, integrate, test, and operate a spaceborne national research facility for the validation of advanced automation and robotics technologies. Initially, the concept is envisioned to be implemented through a series of Shuttle-based flight experiments which will utilize telepresence technologies and real-time operational concepts. However, eventually the facility will be capable of a more autonomous role and will be supported by either the Shuttle or the Space Station. To ensure incorporation of leading-edge technology in the facility, performance capability will periodically and systematically be upgraded by the solicitation of recommendations from a user advisory group. The facility will be managed by NASA, but will be available to all potential investigators. Experiments for each flight will be selected by a peer review group. Detailed definition and design is proposed to take place during FY 86, with the first SMART flight projected for FY 89. This paper discusses the objectives and rationale for the proposed SMART Program, potential implementation scenarios, and the management approach. The main purpose of the paper is to make the reader aware of this upcoming program, and to encourage participation beginning with the conceptual definition phase.</p>			
17 Key Words (Suggested by Author(s)) Automation Robotics Space facility SMART facility		18 Distribution Statement Unlimited Subject category - 12	
19 Security Classif (of this report) Unclassified	20 Security Classif (of this page) Unclassified	21 No of Pages 9	22 Price* A02

End of Document