

**NASA
Technical
Paper
2464**

September 1985

NASA-TP-2464 19850026994

Sound Speed Measurements in Liquid Oxygen-Liquid Nitrogen Mixtures

Allan J. Zuckerwar
and David S. Mazel

SEP 16 1985
LANGLEY RESEARCH CENTER
LIBRARY



NASA
Technical
Paper
2464

1985

Sound Speed Measurements in Liquid Oxygen–Liquid Nitrogen Mixtures

Allan J. Zuckerwar
Langley Research Center
Hampton, Virginia

David S. Mazel
Old Dominion University
Norfolk, Virginia

NASA

National Aeronautics
and Space Administration

Scientific and Technical
Information Branch

Introduction

The transfer of liquid oxygen (LOX) from a storage vessel to a rocket engine generally requires the use of a pressurizing gas at high pressures. The primary criteria for the choice of gas are low cost, safety, and immiscibility with liquid oxygen. Among the common gases, helium, nitrogen, and oxygen itself have been considered. Helium is expensive, and oxygen is hazardous at high pressures. The remaining gas, nitrogen, unfortunately is miscible with oxygen and causes dilution and loss of engine performance.

The effects of pressurized gaseous nitrogen (GN_2) at a LOX interface, reported in the late 1950's when the subject was under active investigation (refs. 1 and 2), were confirmed by an independent preliminary study conducted at the Langley Research Center. At even modest GN_2 pressures (a few hundred pounds per square inch), the GN_2 condenses immediately at the interface and forms a liquid layer, which continues to grow as long as the GN_2 is of ample supply and the temperature remains below the condensation temperature at the top of the layer. The liquid nitrogen (LN_2) so produced diffuses into the liquid below it and creates a concentration profile dependent upon time, GN_2 pressure, heat transfer, and lesser factors. The LOX at the bottom of the vessel may retain the purity of its starting condition, even

though at the top it may be highly contaminated. It is desirable to know the liquid level at which the contamination becomes unacceptable, so that the flow of LOX from the storage vessel can be discontinued.

A possible approach to the contamination problem is to monitor the LOX purity in the transfer line between the storage vessel and the rocket engine. Such a capability would serve two purposes. First, an operator could terminate a test when the LOX contamination reached an unacceptable level. Second, after gaining experience, test engineers could predict the fraction of the LOX in a storage vessel that is useful under a given GN_2 pressure.

The desirable features of a LOX contamination monitor are (1) high sensitivity to LN_2 content, (2) insensitivity to liquid temperature, (3) speed of operation, and (4) nonintrusion into the LOX transfer line. Initially, three physical properties were considered as a basis for LN_2 contamination measurement: dielectric constant, density, and sound speed. The expected performance of a monitor based on each of these three properties is summarized in table I. The selected property should show a large difference between its values for pure LOX and pure LN_2 . This difference is reflected in the "composition coefficient," defined as the percent change in the property for a given percent change in LN_2 content.

TABLE I. COMPARISON OF SELECTED PROPERTIES OF LOX AND LN_2

Property	Value at -195.8°C		Composition coefficient, α_m , %/mole %	Temperature coefficient, α_T , %/ $^\circ\text{C}$	α_m/α_T
	LOX	LN_2			
Dielectric constant ^a . . .	1.500	1.474	-0.000587	-0.001618	0.36
Density, ^b kg/m^3	1205	810	-0.346	-0.004185	83
Sound speed, ^b m/sec . .	1014	859	-0.198	-0.008911	22

^aFrom ref. 15, pp. 5-125.

^bFrom ref. 16, p. 13.

The "temperature coefficient" is the percent change in the property for a given change in temperature. It is desirable that the ratio of the composition coefficient to the temperature coefficient be as high as possible. As can be seen from the table, the dielectric constant has the lowest composition coefficient. This fact together with limited measurement precision makes it unsuitable as a monitoring property. The density, having the highest composition coefficient and a low temperature coefficient, would appear to be the premier property. The detriments to its use, however, far outweigh its merits. A precise measurement would require intrusion into the transfer line and would be unacceptably time consuming. The sound speed, although somewhat inferior to the density with regard to the above-defined performance coefficients, boasts the advantages of measurement precision, speed of operation, and nonintrusive capability. Thus the practical advantages dictate the choice of speed of sound as the basis for monitoring nitrogen content in liquid oxygen.

The purpose of this study is to obtain calibration measurements of sound speed versus composition in LOX-LN₂ mixtures under controlled conditions to such a precision that changes in LN₂ content on the order of a few tenths of a percent can be reliably detected. The sound speed is measured by a simple pulse-echo technique, using a single transducer, within a range of temperatures near the boiling point of LN₂. The results can subsequently be used to determine unknown LN₂ content from sound speed measurements. This monitoring technique is being developed in support of the Langley 8-Foot High-Temperature Tunnel Modification Project (ref. 3).

Apparatus and Experimental Procedure

The test apparatus is shown in figure 1. The acoustic transducer is a 10-mm-diameter lead zirconate titanate (PZT) ceramic, operated at 2 MHz, undamped, and flush mounted to the top plate. It protrudes into the test chamber 0.145 cm to insure proper wetting. The transducer is excited by an ultrasonic pulser-receiver, which sends a short-duration large-amplitude pulse of the order of 250 V with a rise time of approximately 10 nsec to the transducer. A pulse-echo technique is used. The round-trip propagation path of the ultrasonic pulse, including the protrusion of the transducer and correction for thermal expansion, is 27.462 cm. The diameter of the test cell is 9 cm.

A special gating circuit was constructed to generate two square pulses from the transmitted pulse and the first reflection. Since these pulses are unsuited

for triggering a frequency counter directly, the gating circuit conditions the signals to a form usable for a timer-counter. The circuit also prevents any false triggering due to the ringing of the transducer. (See fig. 2.)

As the pulse propagates through the liquid, its amplitude diminishes; the transmitted pulse is considerably larger than the first reflection. Thus, the gating circuit is set to a level below the transmitted pulse height and the height of the first reflection but above the height of all succeeding reflections. A reference voltage is applied to one input of a comparator. The other input of the comparator is connected to the pulser-receiver, which provides the signals from the transducer. The comparator yields a pulse at the beginning of the transmitted signal and at the beginning of the first reflection. Since the distance between the transducer and the reflector is large, the rise time of the transmitted pulse is negligible compared with the transit times of interest. The two pulses from the comparator are sent to a one-shot digital integrated circuit, which generates a square pulse at the beginning of the transmitted pulse and at the beginning of the first reflection. The time between the square pulses is measured with the timer-counter.

The test cell is contained within a Dewar filled with LN₂, as shown in figure 1. In this manner, the test mixture is kept at a uniform and regulated temperature. The piping into the apparatus is insulated to facilitate the flow of LN₂ and LOX. The temperature of the test mixture is measured with a copper-constantan thermocouple immersed halfway in the test mixture (not shown in the figure). Hence, the temperature can be monitored continuously.

The first step in the measurement procedure is to purge the system of any water vapor and impurities. When the test liquid is pure LN₂, gaseous nitrogen (GN₂) is flushed through the system. If the test liquid is to contain any LOX, gaseous oxygen (GO₂) is flushed through the system. The use of GO₂ is especially important in a pure LOX test to prevent any GN₂ in the system at the start of the test from condensing and contaminating the mixture. The purge gas enters the test cell through fill tube #1 and exits through the vent tube.

After the system is purged, the Dewar is filled through fill tube #2 to precool the test cell. The LN₂ and LOX are transferred to the system through fill tube #1, with pressure created from the evaporation of some of the liquid itself in the holding tanks. The coolant is the LN₂ contained in the Dewar. The amount of LN₂ admitted to the Dewar is regulated with a solenoid controlled by a sensor (not shown in the figure) at the top of the Dewar. Once the test cell is sufficiently cold, the test mixture is established.

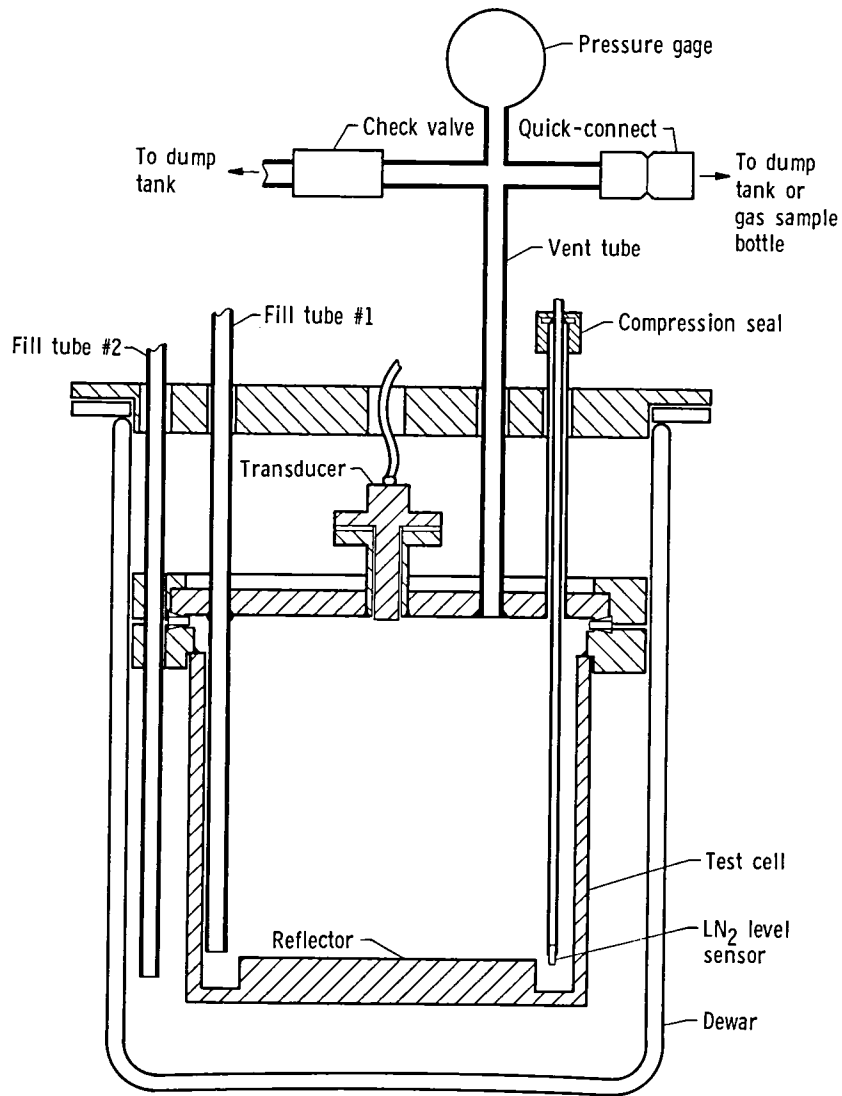

Figure 1. Essential components of test apparatus (not to scale).

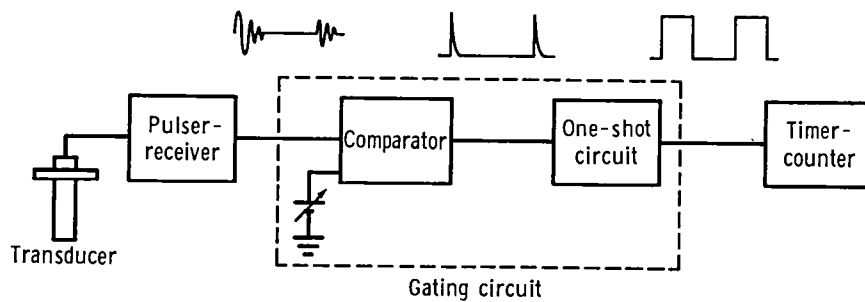

Figure 2. Block diagram of electronic instrumentation. Gating circuit converts transmitted and first reflected acoustic pulses to a form suitable for triggering an electronic timer-counter. Comparator reference level is set to block succeeding reflections.

The LN₂ is admitted to the test cell first. A LN₂ level sensor, the level of which can be adjusted, activates a solenoid which regulates the flow of LN₂ into the test cell. The level of this sensor is preset according to the amount of LN₂ desired in the mixture. The sensor has a compression seal to prevent leaks. When the level of LN₂ reaches the sensor, the solenoid closes and a red light is illuminated on the solenoid control box. The LOX is then introduced into the system until it fills the test cell. The turbulence generated during the filling operation is assumed to assure mixing of the liquids. When the test cell is full, a reflection is received by the transducer as monitored with an oscilloscope. Once a reflection is seen, the flow of LOX is halted. Measurements of temperature and transit time are now taken. The temperature within the test cell decreases as the mixture is cooled by the LN₂ in the Dewar. The temperature measurements vary from the initial temperature of the test mixture to the temperature of the LN₂. The range encountered is approximately -198°C to -188°C . The pressure P in the test cell is 1 atm (101.325 kPa), except in the case of pure LN₂, for which the saturation pressure prevails. The test samples included "pure" LOX (0.236 mole percent LN₂), "pure" LN₂ (99.945 mole percent LN₂), and five LOX-LN₂ mixtures with LN₂ content ranging from 0.86 to 14.25 mole percent. (See appendix.)

After the measurements are completed, the Dewar is removed to expose the test cell to the surroundings. As the test cell warms up, two gas samples are taken as explained in the next section.

For safety, the entire test apparatus is specially cleaned to be free from any hydrocarbons. The gas sample bottles are evacuated through a cold trap prior to the experiment. Also, any expelled gas is vented to a dump tank away from the test site. These precautions prevent any hydrocarbons from the pump or the surroundings from contacting the liquid oxygen and possibly causing combustion.

Measurement of LN₂ Content

The composition of the liquid mixture is the most difficult quantity to measure in the experiment. The LN₂ content cannot be determined accurately from the known height of the LN₂ introduced into the test cell for two reasons. First, the O₂ introduced afterward, a mixture of liquid and vapor, is initially much warmer than the LN₂ and causes some of the latter to evaporate. Second, a small quantity of the O₂ filling the test cell overflows through the vent tube before the ultrasonic echoes appear and possibly takes some of the N₂ with it. Alternatively, collecting a liquid sample directly in a sample bottle would provide an

accurate representation of the test liquid to be analyzed but would require an elaborate pressure relief capability because of the vast expansion of the liquid upon evaporating. If vapor from the evaporated liquid, on the other hand, is collected in a gas sample bottle, then the composition of the vapor is not representative of the composition of the liquid for most binary mixtures because of preferential evaporation of one component. In the sampling method employed here, two gas sample bottles capture the vapor of the warming liquid in such a manner as to overcome the difficulty of preferential evaporation. One sample is taken at the beginning and the other near the end of the evaporation period.

The principle of the method is illustrated with the aid of the LOX-LN₂ phase diagram shown in figure 3(a). The phase boundaries, "liquidus" L and "vaporus" V , are shown on the temperature-composition plane for two pressures, 1 and 2 atm. In the special case of a pure substance, both phase boundaries converge to the boiling point of the liquid. In the binary mixture, the liquid and vapor coexist in equilibrium at a temperature between the two boiling points. The intersections of an isotherm with the liquidus and vaporus determine the composition of the liquid and vapor, respectively. In the following discussion, the temperature and composition (mole fraction of LN₂) at a point on the diagram, are designated by T and x , respectively, with the point on the diagram as a subscript. For example, T_A and x_A represent the temperature and composition, respectively, at point A .

Suppose the test liquid contains a mole fraction x_A of LN₂. Then the starting point of the liquid upon removal of the Dewar is point A at the boiling temperature of LN₂. As the liquid warms it proceeds to point B , located at some temperature T_B below the boiling point of LOX, and vapor appears having the composition x_C . Because of the small volume above the test cell, the pressure rises very rapidly and is limited to about 2 atm by the check valve shown in figure 1. The phase boundaries rise to those of $P = 2$ atm, and evaporation ceases. The liquid continues to warm until it reaches point D , which has a mole fraction $x_D \approx x_A$ because the N₂-rich vapor is small in volume. Vapor of composition x_E continues to be produced and escapes through the check valve.

A few minutes after the pressure gage indicates a pressure $P > 10$ psi, the valve to the first gas sample bottle is opened. The available volume above the liquid increases suddenly from a few to 1000 ml, and the pressure drops to a very low value, as observed on the pressure gage. The liquid, now in a superheated state as indicated by point D in figure 3(b), evapo-

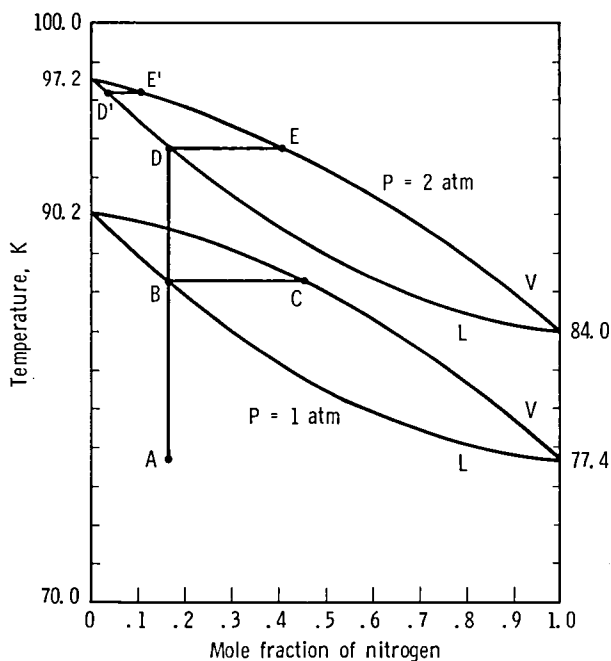

(a) At pressures of 1 and 2 atm.

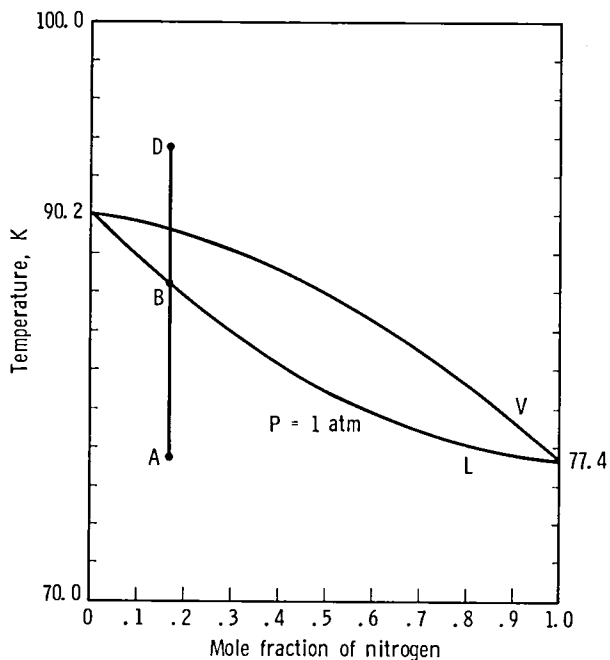

(b) Showing state of mixture (point D) immediately after first gas sample bottle is opened.

Figure 3. Phase diagram of LOX-LN₂ system.

rates immediately up to the pressure permitted by the check valve, and a vapor having a composition $x_D \approx x_A$ fills the gas sample bottle. The vapor is somewhat rich in N₂ because of the evaporation that takes place at isotherm $B-C$ (fig. 3(a)).

As the liquid continues to absorb heat, both the liquid and vapor become increasingly rich in O₂. Near the end of the evaporation period, when little liquid is left, the pressure gradually drops below the threshold pressure of the check valve. The liquid has shifted to point D' and the vapor to point E' ; both richer in O₂ than the starting liquid. At this time the valve to the second gas sample bottle is opened, and again the sudden volume and pressure changes bring the liquid to a superheated state. Because the volume above the liquid is now much larger than before, the change in pressure is not so drastic. The vapor in the sample bottle is composed of the liquid evaporating at composition D' and the vapor already present at composition E' . The composition of the test liquid is estimated to be the mean of the readings of the first and second samples; the two readings are taken to be the error bounds. The uncertainty in the LN₂ content of the mixture is greater at higher concentrations than at lower concentrations. The gas samples were sent to an independent laboratory for analysis by gas chromatography.

Results

Figures A1 through A7 (appendix) show the sound speed versus temperature for each of the seven LOX-LN₂ compositions, along with the tabulated data. The pressure $P = 1$ atm for all the data sets except for pure LN₂, for which the pressure is the saturation pressure at the given temperature. (See table AI.) The line in each figure represents the linear best fit, from which the sound speed at $T = -195.8^\circ\text{C}$, the boiling point of LN₂ at 1 atm, is determined. This will be used as the reference temperature in a practical LOX contamination monitor. Because of a slower cooling rate at low temperatures, more data were taken at colder than at warmer temperatures. The least squares fit was obtained by weighting the data inversely with the number of points at each temperature.

Figures 4(a) and 4(b) show a plot of sound speed versus LN₂ content. The best fit quadratic relationship between sound speed c and LN₂ content M at $T = -195.8^\circ\text{C}$ and $P = 1$ atm is the following:

$$c = 1009.05 - 1.8275M + 0.0026507M^2 \quad (1)$$

where c is in meters per second and M is in mole percent. Equation (1) yields a value of 1009.05 m/sec for pure LOX and a value of 852.8 m/sec for pure LN₂. The standard deviations of the coefficients are 0.26, 0.043, and 0.000417 m/sec, respectively. The deviation of the measured values from those given by equation (1) is 0.1 percent in the worst case.

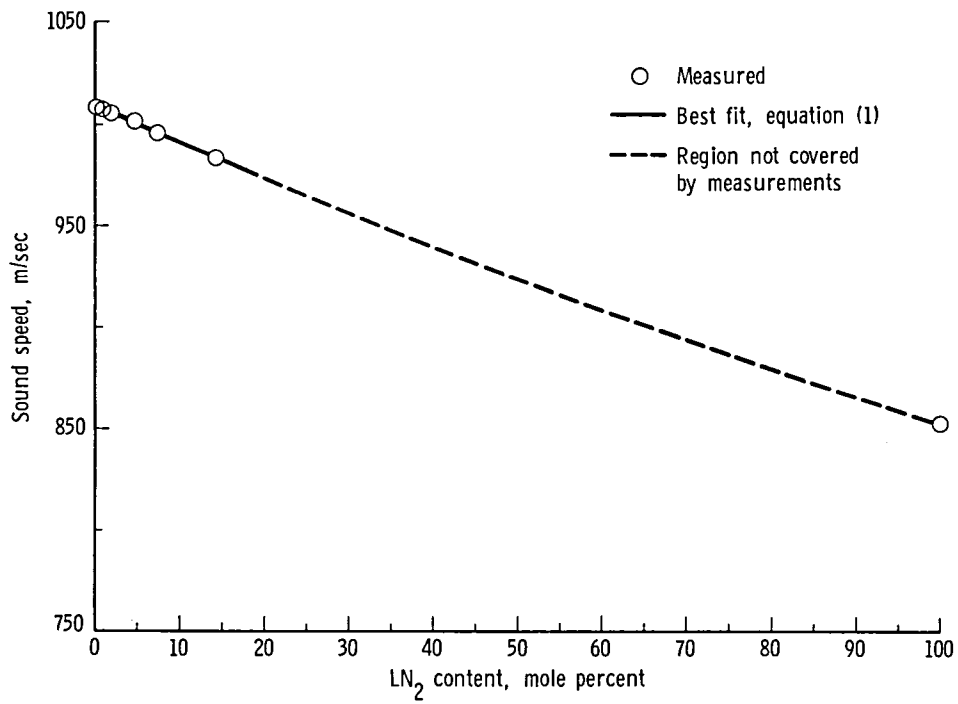

(a) Over full range of compositions.

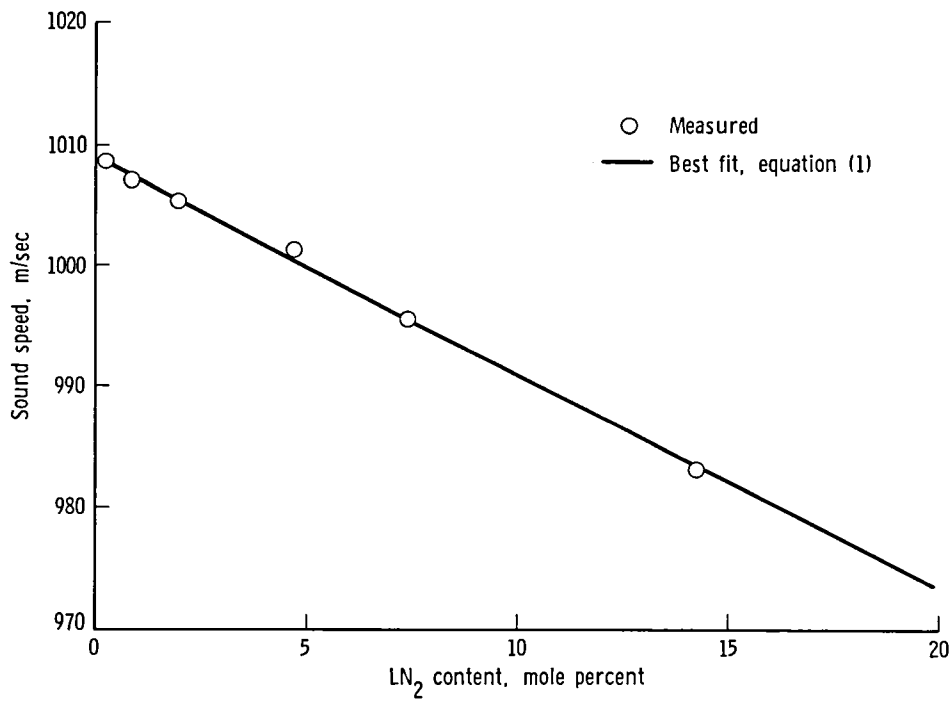

(b) For low LN₂ content.

Figure 4. Sound speed in LOX-LN₂ mixtures.

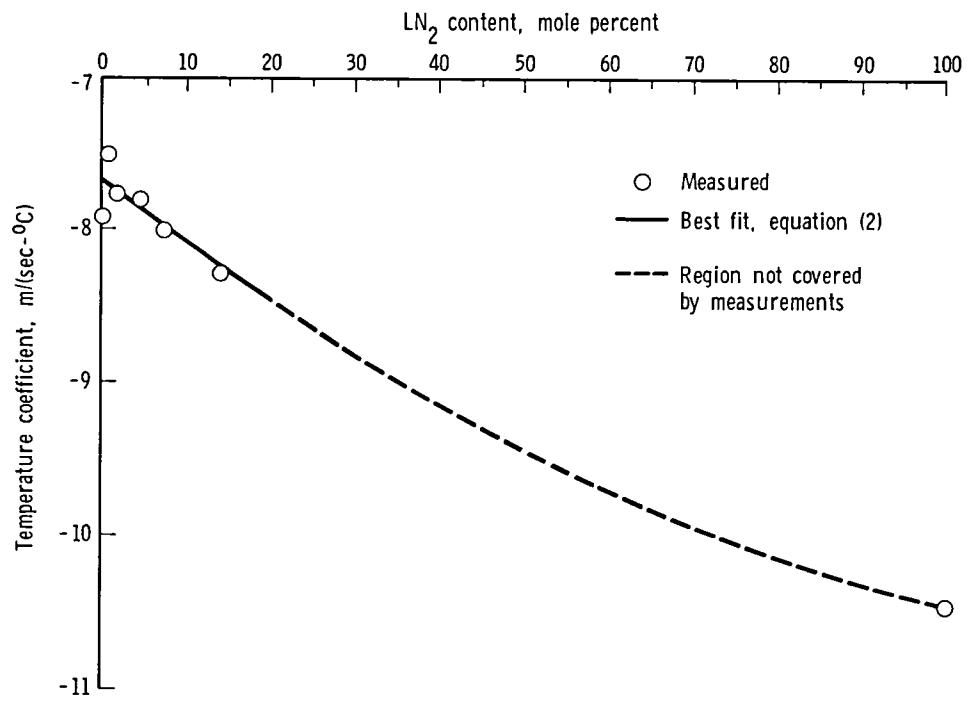

Figure 5. Temperature coefficient of sound speed in LOX-LN₂ mixtures.

Figure 5 shows a plot of the temperature coefficient versus LN₂ content. The best fit under the above conditions is given by

$$\frac{dc}{dT} = -7.6779 - 0.042766M + 0.00014916M^2 \quad (2)$$

where dc/dT is in m/(sec-°C). The standard deviations of the coefficients are 0.085, 0.014, and 0.000135 m/(sec-°C), respectively.

Analysis of Error

The error in the determination of the sound speed consists of two parts: direct measurement error and diffraction error. Since

$$c = c(T, M, L, \tau) \quad (3)$$

where $2L$ is the propagation path and τ is the transit time, the total error ϵ , with cross terms neglected, can be written

$$\epsilon = \left| \frac{dc}{c} \right| = \left| \frac{1}{c} \frac{\partial c}{\partial T} dT \right| + \left| \frac{1}{c} \frac{\partial c}{\partial M} dM \right| + \left| \frac{1}{c} \frac{\partial c}{\partial L} dL \right| + \left| \frac{1}{c} \frac{\partial c}{\partial \tau} d\tau \right| + \left| \frac{dc_d}{c} \right| \quad (4)$$

$$\epsilon = \epsilon_T + \epsilon_M + \epsilon_L + \epsilon_\tau + \epsilon_d$$

in which the ϵ terms are the error contributions indicated by their subscripts, and the last term ϵ_d is the diffraction error. Here, c_d is the sound speed of the diffracted wave.

The temperature error is obtained from equation (2) as follows:

$$\begin{aligned} \frac{\partial c}{\partial T} &= -7.688 \text{ m/(sec-°C) for the purest LOX} \\ &\text{sample } (M = 0.236 \text{ mole } \%) \\ &= -10.462 \text{ m/(sec-°C) for the purest LN}_2 \\ &\text{sample } (M = 99.945 \text{ mole } \%) \end{aligned}$$

Since the estimated error in the temperature reading is $\pm 0.2^\circ\text{C}$, the temperature error is

$$\begin{aligned} \epsilon_T &= \pm \frac{1}{1009} \times 7.919 \times 0.2 \times 100 = \pm 0.157\% \\ &\text{for the purest LOX sample} \\ &= \pm \frac{1}{853} \times 10.462 \times 0.2 \times 100 = \pm 0.245\% \\ &\text{for the purest LN}_2 \text{ sample} \end{aligned}$$

The composition error is obtained from equation (1) as follows:

$$\begin{aligned} \frac{\partial c}{\partial M} &= -1.828 \text{ m/(sec-mole } \%) \text{ for the purest} \\ &\text{LOX sample} \\ &= -1.298 \text{ m/(sec-mole } \%) \text{ for the purest} \\ &\text{LN}_2 \text{ sample} \end{aligned}$$

For the purest LOX sample, the uncertainty in LN₂ content from the analyses is ± 0.1385 percent, and for the purest LN₂ sample, the uncertainty in LOX content is ± 0.0052 percent. The composition error is

$$\begin{aligned} \epsilon_M &= \pm \frac{1}{1009} \times 1.828 \times 0.1385 \times 100 \\ &= \pm 0.0251\% \text{ for the purest LOX sample} \\ &= \pm \frac{1}{853} \times 1.298 \times 0.0052 \times 100 \\ &= \pm 0.0008\% \text{ for the purest LN}_2 \text{ sample} \end{aligned}$$

The error in the propagation path measurement is estimated as $\pm 5 \times 10^{-5}$ m (± 0.002 in.) out of a total propagation path of $2L = 0.2746$ m after correction for thermal expansion. The error is

$$\epsilon_L = \frac{dL}{2L} = \pm \frac{5 \times 10^{-5}}{0.2746} \times 100 = \pm 0.018\%$$

The error in the transit time measurement is ± 0.1 μsec , the resolution of the digital counter, out of a typical transit time of 275 μsec . Thus

$$\epsilon_\tau = \frac{d\tau}{\tau} = \pm \frac{0.1}{275} \times 100 = \pm 0.036\%$$

The diffraction error is taken from reference 4 (p. 288) and is expressed as

$$\epsilon_d = \frac{dc_d}{c} = \frac{\lambda^{3/2}}{2\pi^2 D (2L)^{1/2}}$$

where λ is the acoustical wavelength and D is the diameter of the transducer. Using $\lambda = 0.0005$ m, $D = 0.00635$ m, and $2L = 0.2746$ m, one obtains

$$\epsilon_d = \frac{dc_d}{c} \times 100 = \pm 0.0172\%$$

The sum of all the contributions to the error is

$$\begin{aligned} \epsilon &= \pm 0.25\% \text{ for pure LOX} \\ &= \pm 0.32\% \text{ for pure LN}_2 \end{aligned}$$

Thus LOX contamination on the order of 1 percent should be detectable by this technique.

Comparison With Past Results

A summary of the most recent measurements* of the sound speed in LN₂ at -195.8°C (77.35 K) and 1 atm appears in figure 6 (refs. 6-13). The results are mutually consistent within the limits of error except for reference 13, which shows a discrepancy that cannot be explained by the experimental error. For this reason it is not included in the computation of the mean sound speed, which turns out to be 852.9 m/sec and is shown by the dashed line. Error bars are not reported for any of the data of Van Itterbeek and Van Dael (refs. 6, 7, and 9) and Van Dael et al. (ref. 8) and consequently cannot be shown. The measurement of Pine (ref. 10) was taken in the 3-5 GHz range, well beyond the range of the other measurements; the sound speed may be lower at these frequencies because of dispersion associated with some physical process in the liquid. Dobbs and Finegold (ref. 12) suggest that their value may be low because of a systematic measurement error, for they obtained low values in other liquids, both cryogenic and noncryogenic. Thus it is concluded that the most probable value for the sound speed in LN₂ is 852.9 m/sec ± 0.1 percent at -195.8°C.

A similar summary for the sound speed in LOX is shown in figure 7. For these cases the value at -195.8°C and 1 atm is interpolated from the reported experimental points. The two older values obtained by Van Itterbeek and Van Dael (refs. 6 and 7) are systematically higher than their latest value (ref. 8) and shift the mean value to 1009.65 m/sec. It is noteworthy that the values of references 8 and 14 and that of the present work agree within 0.025 percent, and these are taken to represent the most probable value of the sound speed in LOX. Using these three values, one obtains 1009.01 m/sec ± 0.015 percent for the mean at -195.8°C.

* The measurement of another recent group (ref. 5) is not included because it is reported on a graph which is too coarse to permit a sufficiently precise determination. An attempt to obtain the data in numerical form from the authors proved unsuccessful.

Summary of Results

The sound speed in liquid oxygen (LOX), liquid nitrogen (LN₂), and five LOX-LN₂ mixtures was measured by an ultrasonic pulse-echo technique at temperatures in the vicinity of -195.8°C, the boiling point of N₂ at a pressure of 1 atm. The LN₂ content of a mixture was determined by a technique whereby the liquid was brought to a superheated state and the vapor captured in a gas sample bottle. The vapor was subsequently analyzed by gas chromatography. Under reference conditions (-195.8°C, 1 atm), the measurements yield the following relationship between sound speed c in meters per second and LN₂ content M in mole percent: $c = 1009.05 - 1.8275M + 0.0026507M^2$. The sound speeds are accordingly 1009.05 m/sec ± 0.25 percent for pure LOX and 852.8 m/sec ± 0.32 percent for pure LN₂. These together with measurements from past investigators yield mean sound speeds of 1009.01 m/sec ± 0.015 percent and 852.9 m/sec ± 0.1 percent for pure LOX and pure LN₂, respectively. The temperature coefficients of the sound speed are -7.6779 m/(sec-°C) for pure LOX and -10.462 m/(sec-°C) for pure LN₂. Measurement of sound speed should prove an effective means of monitoring contamination of LOX by LN₂.

NASA Langley Research Center
Hampton, VA 23665-5225
May 15, 1985

After receiving the proof, the authors became aware of the measurements in the following reference:

Van Itterbeek, A.; and Van Dael, W.: Measurements on the Velocity of Sound in Liquid Oxygen and Nitrogen and Mixtures of Nitrogen and Oxygen Under High Pressures. *Bull. Inst. Int. Froid, Annee*, vol. 1, 1958, pp. 295-306.

This study reports the sound speed of LOX-LN₂ mixtures containing 19.1, 37.9, and 56.2 percent LN₂. The measured values agree with those obtained from equation (1) within 0.237, 0.007, and 0.304 percent, respectively.

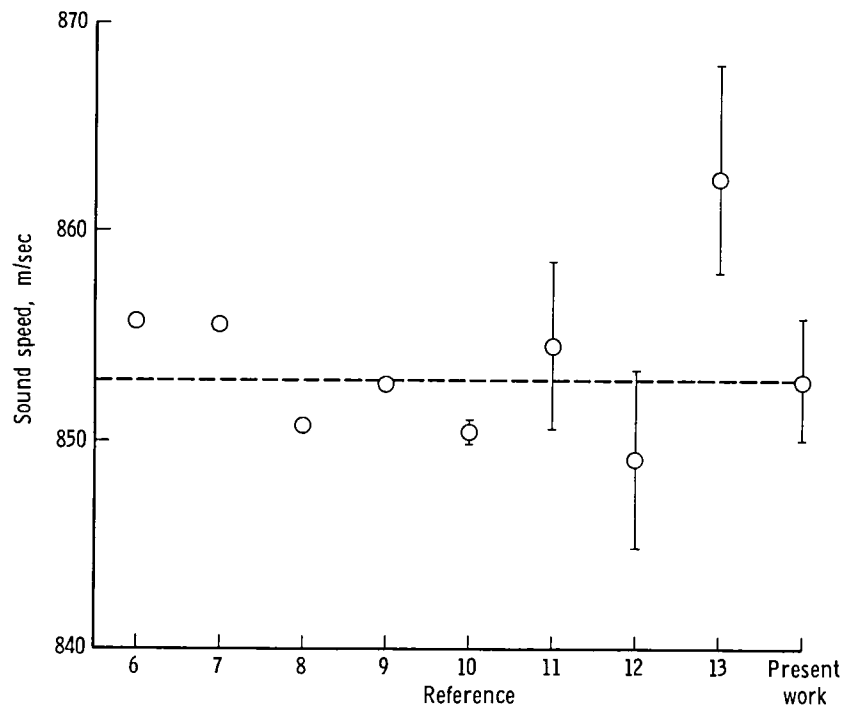

Figure 6. Summary of most recent sound speed measurements in LN₂ at reference conditions, $T = -195.8^{\circ}\text{C}$ and $P = 1 \text{ atm}$.

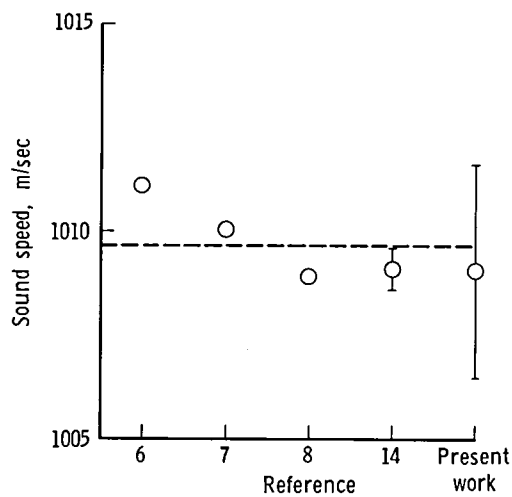

Figure 7. Summary of most recent sound speed measurements in LOX at reference conditions, $T = -195.8^{\circ}\text{C}$ and $P = 1 \text{ atm}$.

Appendix

Sound Speed in Liquid Nitrogen-Liquid Oxygen Mixtures Versus Temperature

The sound speed is plotted and tabulated against temperature for each of the seven compositions used in this study. The line in each figure represents the best fit to the equation

$$c = A + BT \quad (A1)$$

where the sound speed c is in meters per second, and the temperature T is in degrees centigrade. The following additional information is included: LN₂ content (mole percent) in the two gas samples, mean LN₂ content of the two samples, best fit parameters A and B of equation (A1), and sound speed at $T = -195.8^\circ\text{C}$ (the boiling point of LN₂ at 1 atm). All measurements were taken at $P = 1$ atm except those of figure A7, for which the pressure is the saturation pressure. (See table AI.)

TABLE AI. VAPOR PRESSURE OF NITROGEN OVER THE RANGE OF EXPERIMENTAL TEMPERATURES

TEMPERATURE (°C)	PRESSURE (atm)	TEMPERATURE (°C)	PRESSURE (atm)
-190	1.869	-194.2	1.2
-190.2	1.832	-194.4	1.173
-190.4	1.795	-194.6	1.147
-190.6	1.758	-194.8	1.12
-190.8	1.722	-195	1.093
-191	1.685	-195.2	1.067
-191.2	1.649	-195.4	1.045
-191.4	1.618	-195.6	1.022
-191.6	1.586	-195.8	1
-191.8	1.554	-196	0.977
-192	1.523	-196.2	0.954
-192.2	1.491	-196.4	0.932
-192.4	1.46	-196.6	0.909
-192.6	1.428	-196.8	0.887
-192.8	1.396	-197	0.864
-193	1.365	-197.2	0.842
-193.2	1.334	-197.4	0.823
-193.4	1.308	-197.6	0.804
-193.6	1.281	-197.8	0.786
-193.8	1.254	-198	0.767
-194	1.227	-198.2	0.748

TEMPERATURE (°C)	SOUND SPEED (m/sec)	TEMPERATURE (°C)	SOUND SPEED (m/sec)
-188.7	951.2	-195.2	1003.7
-188.9	953.2	-195.2	1004
-189	955.2	-195.2	1004.4
-189.2	956.5	-195.2	1004.4
-189.2	957.8	-195.2	1004.4
-189.4	959.2	-195.2	1004.8
-189.4	959.5	-195.2	1004.8
-189.5	961.2	-195.2	1005.1
-189.7	963.5	-195.4	1005.1
-189.9	964.2	-195.2	1005.5
-190.2	965.6	-195.4	1005.9
-190.4	966.2	-195.4	1006.3
-190.9	969.3	-195.4	1006.3
-191	970	-195.4	1006.3
-191.2	970.3	-195.4	1006.6
-191.2	971.4	-195.4	1006.6
-191.4	972.1	-195.4	1007
-191.4	972.4	-195.5	1007
-191.5	973.4	-195.5	1007
-191.7	974.1	-195.5	1007.7
-191.7	974.8	-195.7	1007.7
-191.7	975.5	-195.5	1008.1
-192	979.3	-195.7	1007.7
-192.2	981.8	-195.5	1008.1
-192.4	981.8	-195.7	1008.1
-192.5	983.2	-195.5	1008.5
-192.7	983.9	-195.7	1008.1
-192.7	984.6	-195.5	1008.1
-192.9	985.7	-195.7	1008.8
-192.9	986.7	-195.7	1008.5
-193	987.8	-195.7	1008.8
-193.4	989.6	-195.7	1008.8
-193.5	990.3	-195.7	1008.8
-193.7	991	-195.7	1008.8
-193.7	991.4	-195.7	1009.2
-193.7	992.1	-195.7	1008.8
-193.7	992.4	-195.7	1009.2
-193.7	993.2	-195.7	1009.6
-194	994.6	-195.9	1009.6
-194	995.3	-195.9	1010
-194.2	995.7	-195.9	1010
-194.2	996.8	-195.9	1010
-194.4	996.8	-195.9	1010
-194.2	997.5	-195.9	1010
-194.4	997.8	-196	1010.3
-194.5	998.6	-196	1010.3
-194.7	998.9	-195.9	1010.7
-194.7	1000	-195.9	1010.3
-194.9	1001.1	-195.9	1010.7
-194.9	1001.5	-196	1010.7
-194.9	1001.8	-196.2	1011.1
-194.9	1002.2	-196	1011.1
-194.9	1002.6	-196	1011.4
-195	1002.6	-196.2	1011.8
-195.2	1002.9	-196.2	1012.2
-195	1003.3	-196.2	1012.2
-195	1003.3	-196.2	1012.6
-195.2	1003.7	-196.2	1012.6

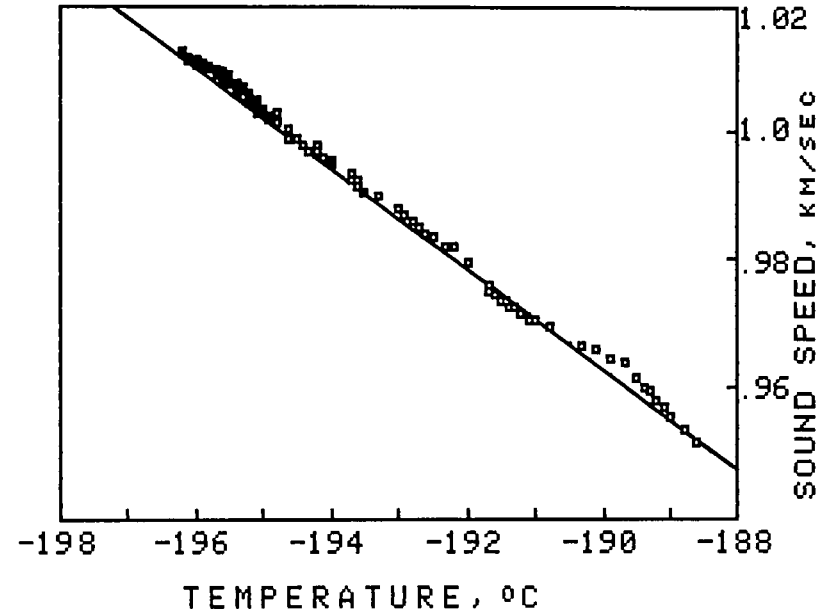

Figure A1. Sound speed in LOX-LN₂ mixture with mean LN₂ content of 0.23645 mole %. LN₂ content = 0.375 mole % for sample 1 and 0.0979 mole % for sample 2; $P = 1$ atm.

Best fit parameters: $A = -542$ m/sec
 $B = -7.919$ m/(sec-°C)

Sound speed at $-195.8^{\circ}\text{C} = 1008.5$ m/sec

TEMPERATURE (°C)	SOUND SPEED (m/sec)	TEMPERATURE (°C)	SOUND SPEED (m/sec)
-194.4	997.5	-195.7	1008.1
-194.9	998.9	-195.9	1008.1
-194.9	999.3	-196	1008.1
-194.9	1000	-195.9	1008.1
-195	1000.8	-195.9	1008.1
-195	1000.8	-195.9	1008.1
-195	1000.8	-195.9	1008.1
-195	1001.1	-195.9	1008.1
-195.2	1001.5	-195.9	1008.5
-195.2	1002.2	-195.9	1008.5
-195.2	1002.2	-195.9	1008.5
-195.2	1002.6	-195.9	1008.5
-195.4	1002.6	-195.9	1008.5
-195.4	1005.1	-196	1008.8
-195.2	1002.9	-196.2	1008.8
-195.2	1003.7	-196	1008.8
-195.2	1003.7	-196	1008.8
-195.2	1003.7	-196	1007.4
-195.2	1004	-195.9	1008.8
-195.2	1004.4	-195.9	1009.2
-195.2	1004.4	-196.2	1008.8
-195.4	1004.4	-196	1009.2
-195.4	1004.4	-196.2	1009.2
-195.4	1004.4	-196	1009.2
-195.4	1004.4	-196.2	1009.2
-195.4	1004.8	-196	1009.2
-195.7	1005.1	-196.2	1009.2
-195.4	1005.1	-196.2	1009.6
-195.5	1005.1	-196.2	1009.2
-195.7	1005.5	-196.2	1009.2
-195.5	1005.5	-196.2	1009.2
-195.5	1005.5	-196	1009.2
-195.5	1005.9	-196.2	1009.2
-195.7	1005.5	-196.2	1010.3
-195.5	1005.9	-196.2	1010
-195.7	1005.9	-196.2	1010.3
-195.5	1005.9	-196.2	1010
-195.5	1005.9	-196.2	1010
-195.7	1006.3	-196.2	1010.3
-195.5	1006.3	-196	1010.3
-195.7	1006.3	-196.2	1010.3
-195.7	1006.6	-196.2	1010.3
-195.9	1007	-196.2	1010.3
-195.9	1006.6	-196.2	1010.3
-195.9	1006.6	-196.2	1010.3
-195.9	1007	-196.2	1010.3
-195.9	1007	-196.2	1010.3
-195.9	1007	-196.2	1010.3
-195.9	1007	-195.9	1010.7
-195.9	1007.4	-196	1010.7
-195.9	1007.4	-196.2	1010.3
-195.9	1007	-196.2	1010.3
-196	1007.4	-196.2	1010.7
-195.9	1007.4	-196.2	1010.7
-195.7	1007.7	-196.2	1010.7
-195.7	1007.7	-196.2	1010.7
-195.9	1007.4	-196.2	1010.7
-195.9	1007.4	-196.2	1010.7
-195.7	1007.4	-196.2	1010.7
-195.9	1007.7	-196.2	1010.7
-195.7	1007.4	-196.2	1010.7
-195.9	1007.7	-196.2	1010.7
-195.7	1008.1	-196	1010.7
-195.7	1008.1	-196	1010.7

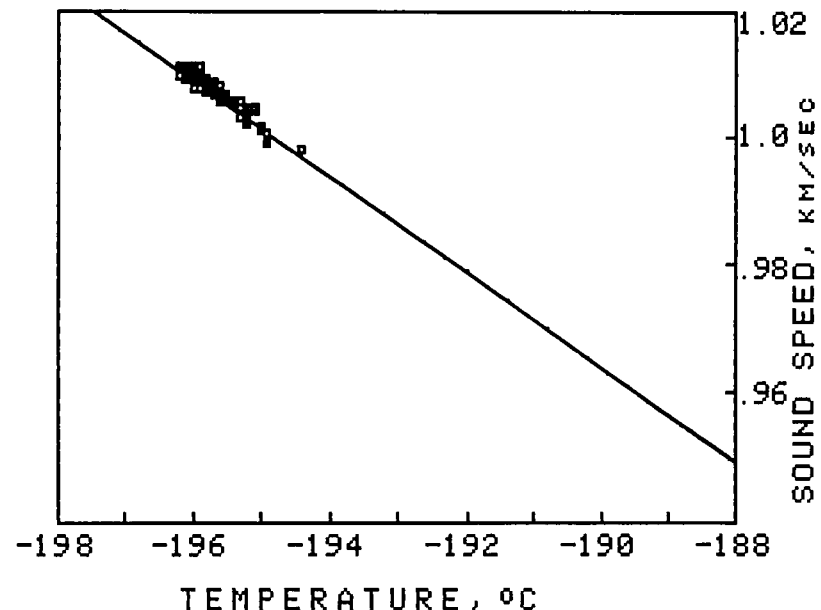

Figure A2. Sound speed in LOX-LN₂ mixture with mean LN₂ content of 0.864 mole %. LN₂ content = 1.03 mole % for sample 1 and 0.698 mole % for sample 2; $P = 1$ atm.

Best fit parameters: $A = -462.6$ m/sec
 $B = -7.506$ m/(sec-°C)

Sound speed at $-195.8^{\circ}\text{C} = 1007$ m/sec

TEMPERATURE (°C)	SOUND SPEED (m/sec)	TEMPERATURE (°C)	SOUND SPEED (m/sec)
-192	976.2	-194.7	996.8
-191.9	976.9	-194.9	996.8
-192.2	978.6	-194.7	997.5
-192.4	980	-194.9	997.8
-192.5	980.4	-194.9	997.8
-192.9	983.2	-194.9	998.2
-192.9	983.9	-194.9	998.2
-193	985	-195	998.6
-193.2	985.3	-195	999.3
-193.4	986	-195	999.7
-193.4	986.7	-195.2	999.7
-193.4	986.7	-195.2	1000
-193.5	987.1	-195.2	1000
-193.5	987.4	-195.2	1000.4
-193.5	988.1	-195.2	1001.5
-193.7	988.5	-195.2	1002.2
-193.7	988.9	-195.4	1002.6
-193.7	989.6	-195.4	1003.3
-193.7	989.9	-195.2	1002.9
-193.9	990.3	-195.4	1003.3
-193.9	991	-195.4	1003.3
-193.9	991.4	-195.4	1003.7
-193.9	991.7	-195.4	1003.7
-194.2	992.1	-195.4	1003.7
-194.2	992.4	-195.4	1003.7
-194.2	993.2	-195.5	1004
-194.2	993.2	-195.5	1004.4
-194.2	993.9	-195.5	1004.4
-194.4	994.2	-195.7	1004.8
-194.4	994.6	-195.7	1004.8
-194.4	995	-195.7	1005.1
-194.4	995.3	-195.7	1005.5
-194.5	996	-195.7	1005.5
-194.7	996.4	-195.7	1005.5
-194.7	996.4	-195.7	1005.5

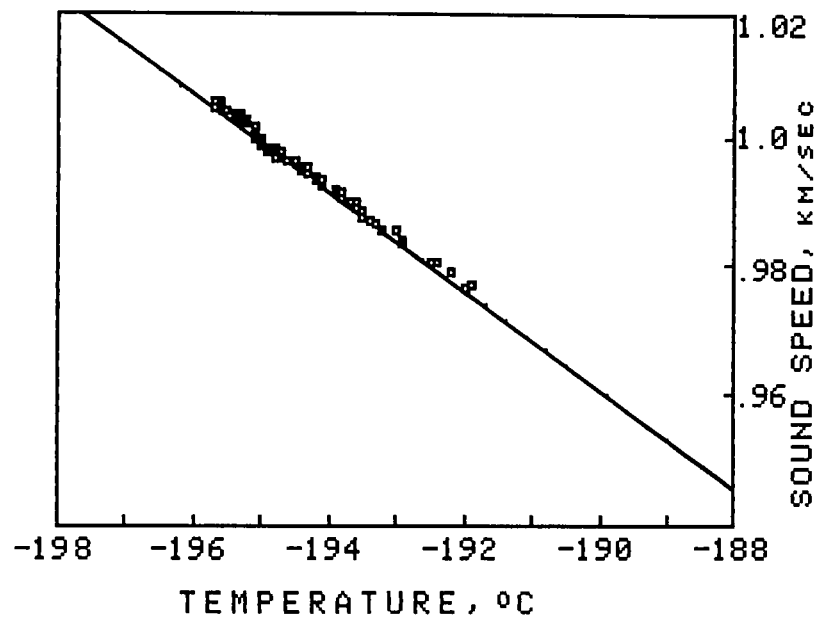

Figure A3. Sound speed in LOX-LN₂ mixture with mean LN₂ content of 1.955 mole %. LN₂ content = 2.34 mole % for sample 1 and 1.57 mole % for sample 2; $P = 1$ atm.

Best fit parameters: $A = -515.1$ m/sec
 $B = -7.766$ m/(sec-°C)

Sound speed at $-195.8^{\circ}\text{C} = 1005.3$ m/sec

TEMPERATURE (°C)	SOUND SPEED (m/sec)	TEMPERATURE (°C)	SOUND SPEED (m/sec)
-189.9	954.8	-194.7	991.7
-190.2	960.5	-194.7	992.1
-190.7	963.9	-194.7	993.2
-190.9	964.9	-194.9	993.5
-191	965.6	-194.9	993.9
-191.2	966.6	-194.9	994.6
-191.5	968.6	-194.9	995
-191.7	969.3	-194.9	995.3
-191.9	970	-194.9	995.7
-191.9	970.3	-195	996
-191.9	971.4	-195.2	996
-192	972.1	-195.2	996.8
-192.2	973.1	-195	997.1
-192.2	973.4	-195.2	997.1
-192.4	974.8	-195.2	997.8
-192.4	975.2	-195.2	998.2
-192.5	975.5	-195.4	998.6
-192.7	977.2	-195.4	998.9
-192.9	977.6	-195.4	999.3
-192.9	979	-195.4	999.3
-193	980.4	-195.4	1000
-193.2	980.7	-195.4	1000
-193.4	981.1	-195.5	1000.8
-193.5	982.1	-195.5	1001.1
-193.7	983.9	-195.5	1001.5
-193.7	984.6	-195.7	1001.5
-193.7	985.3	-195.7	1001.8
-193.9	986.4	-195.7	1002.2
-193.9	987.8	-195.7	1002.6
-194	988.1	-195.7	1002.9
-194.2	988.9	-195.7	1002.9
-194.2	988.9	-195.9	1003.3
-194.4	989.2	-195.9	1003.3
-194.4	989.9	-195.9	1003.7
-194.4	990.3	-196	1004
-194.5	991.4		

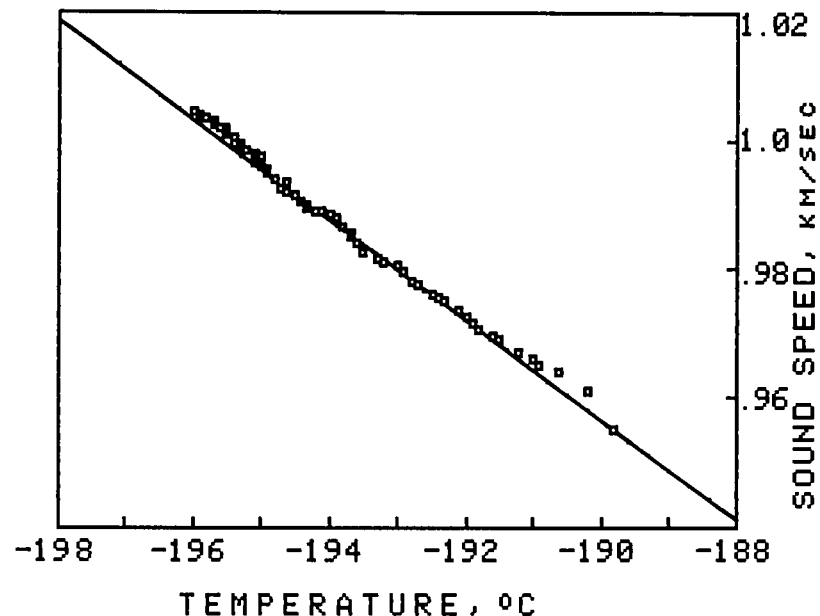

Figure A4. Sound speed in LOX-LN₂ mixture with mean LN₂ content of 4.695 mole %. LN₂ content = 3.74 mole % for sample 1 and 5.65 mole % for sample 2; $P = 1$ atm.

Best fit parameters: $A = -527.4$ m/sec
 $B = -7.808$ m/(sec-°C)

Sound speed at $-195.8^{\circ}\text{C} = 1001.3$ m/sec

TEMPERATURE (°C)	SOUND SPEED (m/sec)	TEMPERATURE (°C)	SOUND SPEED (m/sec)
-191	959.8	-195.2	991
-191.4	962.5	-195	989.6
-191.7	962.9	-195.2	992.1
-191.7	964.5	-195.2	993.5
-191.9	965.6	-195.4	993.9
-192	965.9	-195.4	994.2
-192.2	967.6	-195.4	994.2
-192.2	969	-195.4	992.8
-192.4	969.7	-195.5	995.3
-192.7	971	-195.5	995.3
-192.9	972.1	-195.5	996
-193	973.1	-195.7	996
-193.2	974.1	-195.7	996.4
-193.2	974.8	-195.5	996.4
-193.4	975.5	-195.7	997.1
-193.4	975.9	-195.7	997.5
-193.5	976.6	-195.7	997.5
-193.7	977.2	-195.7	997.8
-193.7	978.3	-195.7	996.4
-193.9	978.6	-195.9	998.2
-193.9	979	-195.9	998.2
-193.9	980	-195.7	998.2
-194	980.7	-195.9	996.8
-194.2	981.4	-195.9	997.1
-194.2	981.8	-195.9	997.1
-194.4	982.5	-195.9	997.1
-194.4	985	-195.9	997.5
-194.5	986	-196	997.8
-194.7	986.7	-196	998.2
-194.7	987.1	-196	998.2
-194.9	986.7	-196	998.6
-194.9	987.8	-196.2	998.9
-194.9	988.1	-196.2	999.3
-195	988.1	-196.2	999.3
-195	990.3		

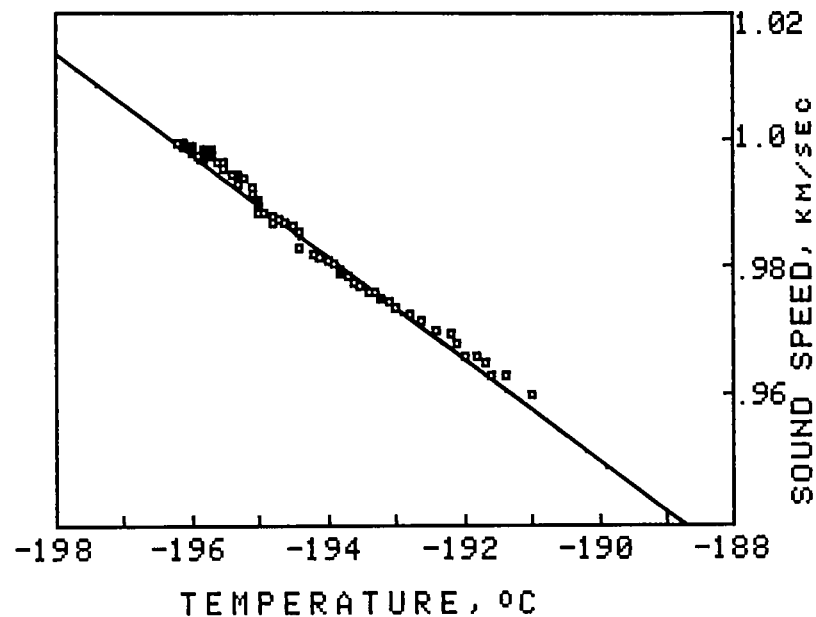

Figure A5. Sound speed in LOX-LN₂ mixture with mean LN₂ content of 7.4 mole %. LN₂ content = 6.91 mole % for sample 1 and 7.89 mole % for sample 2; $P = 1$ atm.

Best fit parameters: $A = -571.6$ m/sec
 $B = -8.004$ m/(sec-°C)

Sound speed at $-195.8^{\circ}\text{C} = 995.6$ m/sec

TEMPERATURE (°C)	SOUND SPEED (m/sec)	TEMPERATURE (°C)	SOUND SPEED (m/sec)
-190.2	937.9	-194.9	976.9
-190.5	939.1	-194.9	977.2
-190.7	940.8	-194.9	977.2
-190.9	942	-195	977.2
-190.9	943.3	-195	977.2
-190.9	945.6	-195	977.6
-191.4	944.6	-195.2	980.7
-191.7	949.5	-195	978.3
-192.2	954.2	-195.2	978.6
-192.4	956.1	-195.2	978.6
-192.5	957.1	-195.2	979
-192.5	957.8	-195.2	979.3
-192.7	958.8	-195.2	979.3
-192.9	959.5	-195.4	979.3
-192.9	960.5	-195.4	979.3
-193.2	961.2	-195.4	979.7
-193.2	961.8	-195.4	979.7
-193.2	962.5	-195.2	980
-193.4	963.5	-195.2	980
-193.5	963.9	-195.4	980.4
-193.7	964.5	-195.4	980
-193.7	965.2	-195.4	980.4
-193.5	966.2	-195.4	980.7
-193.7	966.6	-195.4	980.7
-193.7	966.9	-195.4	980.7
-193.7	967.6	-195.4	981.1
-193.9	967.9	-195.4	981.4
-193.9	968.6	-195.5	981.4
-194	969	-195.4	981.4
-194	969.7	-195.4	981.4
-194	970	-195.5	981.8
-194.2	970.3	-195.4	981.4
-194.2	970.7	-195.4	981.4
-194.4	971	-195.5	981.8
-194.4	971.4	-195.5	982.1
-194.4	972.1	-195.5	982.1
-194.5	972.1	-195.7	981.8
-194.4	972.4	-195.7	982.5
-194.7	972.7	-195.7	982.5
-194.5	973.1	-195.7	982.5
-194.4	973.1	-195.7	982.5
-194.5	973.8	-195.7	982.8
-194.7	974.1	-195.7	982.8
-194.7	974.8	-195.5	982.8
-194.9	974.8	-195.7	983.2
-194.7	975.2	-195.9	982.8
-194.9	975.5	-195.7	982.8
-194.9	975.9	-195.9	983.2
-194.9	976.2	-195.7	983.2
-194.9	976.6	-195.7	983.5
-195	976.6	-195.9	983.5
-195	976.6		

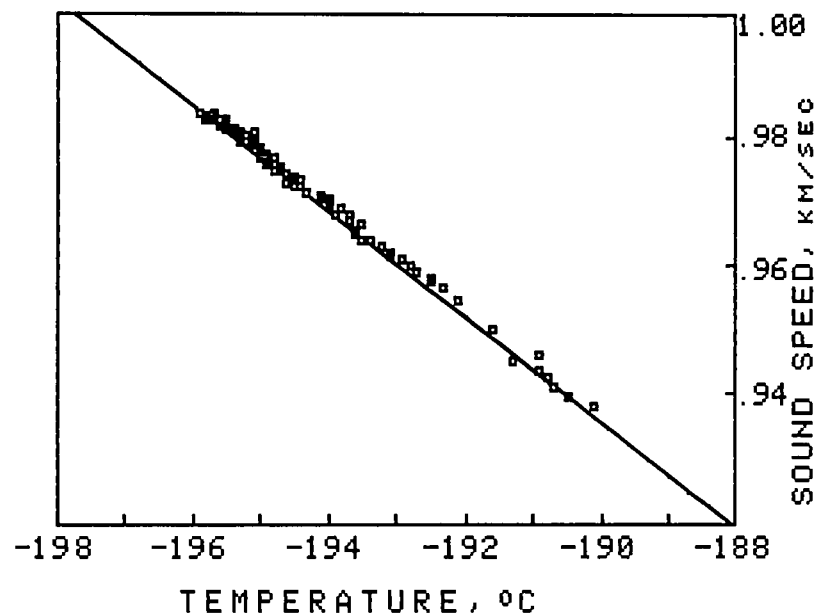

Figure A6. Sound speed in LOX-LN₂ mixture with mean LN₂ content of 14.25 mole %. LN₂ content = 16.8 mole % for sample 1 and 11.7 mole % for sample 2; $P = 1$ atm.

Best fit parameters: $A = -638.2$ m/sec
 $B = -8.282$ m/(sec-°C)

Sound speed at $-195.8^{\circ}\text{C} = 983.2$ m/sec

TEMPERATURE (°C)	SOUND SPEED (m/sec)	TEMPERATURE (°C)	SOUND SPEED (m/sec)
-192.7	820.4	-195.2	846.2
-192.9	823.6	-195.2	846.2
-193.2	824.4	-195.2	846.5
-193.2	825.4	-195.2	846.5
-193.4	826.9	-195.2	846.8
-193.4	827.9	-195.2	847
-193.5	828.9	-195.2	847.3
-193.7	828.9	-195.2	847.3
-193.7	829.1	-195.2	847.5
-193.7	829.6	-195.2	847.8
-193.7	830.9	-195.2	848.1
-193.7	831.4	-195.2	848.3
-193.7	833.6	-195.2	848.6
-193.7	834.7	-195.2	848.9
-193.9	835.7	-195.4	849.1
-194.4	838.2	-195.4	849.1
-194.4	839	-195.2	849.4
-194.4	839.3	-195.4	849.6
-194.4	839.8	-195.5	849.4
-194.4	840	-195.4	849.6
-194.5	840.3	-195.4	849.9
-194.7	840.5	-195.4	849.9
-194.7	840.5	-195.5	849.9
-194.7	841.1	-195.4	850.2
-194.5	841.1	-195.4	850.4
-194.7	841.3	-195.4	851
-194.7	841.6	-195.4	850.7
-194.7	841.8	-195.4	850.4
-194.7	842.1	-195.4	851
-194.9	842.3	-195.4	851.2
-194.7	842.6	-195.5	851.2
-194.7	842.9	-195.7	851.5
-194.7	842.9	-195.5	851.5
-194.7	843.1	-195.5	851.7
-194.9	843.4	-195.7	851.7
-194.9	843.6	-195.7	851.7
-194.9	843.6	-195.5	851.7
-194.9	843.9	-195.7	852
-194.9	844.2	-195.7	852.3
-194.9	844.4	-195.7	852
-195	844.7	-195.7	852.3
-195	844.7	-195.7	852.5
-195	844.9	-195.7	852.8
-194.9	845.2	-195.7	852.8
-195	845.2	-195.7	853.1
-195	845.5	-195.9	853.1
-195	845.7	-195.9	853.1
-195	845.7	-195.9	853.3
-195.2	845.7	-196	853.9

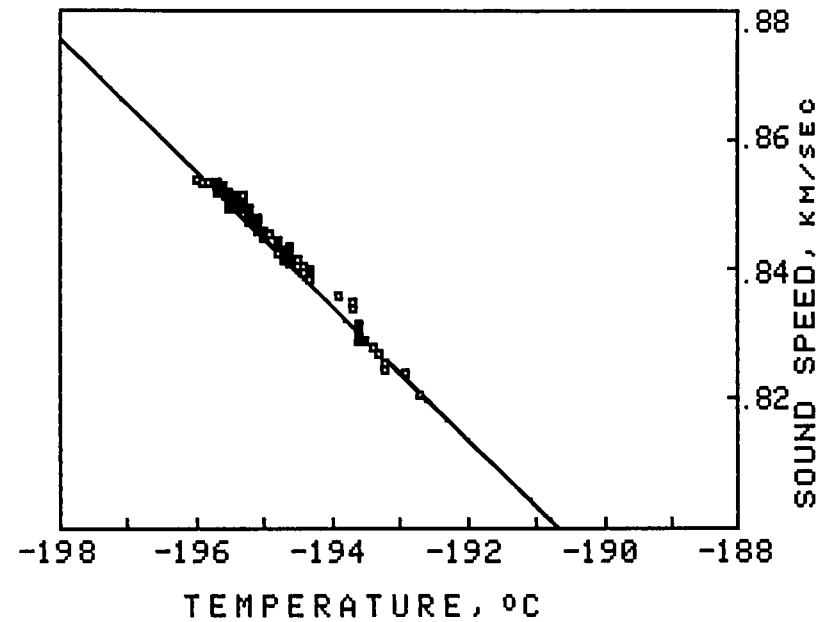

Figure A7. Sound speed in LOX-LN₂ mixture with mean LN₂ content of 99.9448 mole %. LN₂ content = 99.9396 mole % for sample 1 and 99.95 mole % for sample 2; at saturation pressure.

Best fit parameters: $A = -1195.6$ m/sec
 $B = -10.462$ m/(sec-°C)

Sound speed at $-195.8^{\circ}\text{C} = 852.8$ m/sec

References

1. Greenfield, S.: Dilution of Cryogenic Liquid Rocket Propellants During Pressurized Transfer. *Advances in Cryogenic Engineering, Volume 3*, K. D. Timmerhaus, ed., Plenum Press, Inc., 1960, pp. 136-148.
2. Bowersock, D. C.; Gardner, R. W.; and Reid, R. C.: Pressurized Transfer of Cryogenic Liquids. *Advances in Cryogenic Engineering, Volume 4*, K. D. Timmerhaus, ed., Plenum Press, Inc., 1960, pp. 342-356.
3. Kelly, H. N.; and Wieting, A. R.: *Modification of NASA Langley 8-Foot High Temperature Tunnel To Provide a Unique National Research Facility for Hypersonic Air-Breathing Propulsion Systems*. NASA TM-85783, 1984.
4. McSkimin, H. J.: Ultrasonic Methods for Measuring the Mechanical Properties of Liquids and Solids. *Physical Acoustics—Principles and Methods, Volume 1—Part A*, Warren P. Mason, ed., Academic Press, 1964, pp. 271-334.
5. Liebenberg, D. H.; Mills, R. L.; and Bronson, J. C.: Ultrasonic Velocity Measurements in Liquid Nitrogen. *Phys. Lett.*, vol. 57A, no. 2, May 31, 1976, pp. 165-167.
6. Van Itterbeek, A.; and Van Dael, W.: Velocity of Sound in Liquid Oxygen and Liquid Nitrogen as a Function of Temperature and Pressure. *Physica*, vol. 28, 1962, pp. 861-870.
7. Van Itterbeek, A.; and Van Dael, W.: Properties of Some Cryogenic Liquids From Sound Velocity Data. *Advances in Cryogenic Engineering, Volume 9*, K. D. Timmerhaus, ed., Plenum Press, Inc., 1964, pp. 207-216.
8. Van Dael, W.; Van Itterbeek, A.; Cops, A.; and Thoen, J.: Sound Velocity Measurements in Liquid Argon, Oxygen and Nitrogen. *Physica*, vol. 32, no. 3, Mar. 1966, pp. 611-620.
9. Van Itterbeek, A.; and Van Dael, W.: The Velocity of Sound in Liquid Argon and Liquid Nitrogen at High Pressures. *Cryogenics*, vol. 1, no. 4, June 1961, pp. 226-228.
10. Pine, Alan S.: Velocity and Attenuation of Hypersonic Waves in Liquid Nitrogen. *J. Chem. Phys.*, vol. 51, no. 11, Dec. 1, 1969, pp. 5171-5173.
11. Singer, J. R.; and Lunsford, J. H.: Ultrasonic Attenuation and Volume Viscosity in Liquid Nitrogen. *J. Chem. Phys.*, vol. 47, no. 2, July 15, 1967, pp. 811-814.
12. Dobbs, E. Roland; and Finegold, Leonard: Measurement of the Velocity of Sound in Liquid Argon and Liquid Nitrogen at High Pressures. *J. Acoust. Soc. America*, vol. 32, no. 10, Oct. 1960, pp. 1215-1220.
13. Blagoi, Yu. P.; Butko, A. E.; Mikhailenko, S. A.; and Yakuba, V. V.: Velocity of Sound in Liquid Nitrogen, Oxygen, and Argon in the Temperature Range Above the Normal Boiling Points. *Soviet Phys.—Acoustics*, vol. 12, no. 4, Apr.-June 1967, pp. 355-359.
14. Straty, G. C.; and Younglove, B. A.: Velocity of Sound in Saturated and Compressed Fluid Oxygen. *J. Chem. Thermodyn.*, vol. 5, no. 3, 1973, pp. 305-312.
15. Gray, Dwight E., coordinating ed.: *American Institute of Physics Handbook*, Third ed. McGraw-Hill Book Co., c.1972.
16. Schaaffs, W.: Molecular Acoustics. *Landolt-Börnstein Numerical Data and Functional Relationships in Science and Technology, Group II: Atomic and Molecular Physics, Volume 5*, K.-H. Hellwege and A. M. Hellwege, eds., Springer-Verlag, 1967.

1. Report No. NASA TP-2464		2. Government Accession No.		3. Recipient's Catalog No.	
4. Title and Subtitle Sound Speed Measurements in Liquid Oxygen-Liquid Nitrogen Mixtures				5. Report Date September 1985	
				6. Performing Organization Code 505-33-53-14	
7. Author(s) Allan J. Zuckerwar and David S. Mazel				8. Performing Organization Report No. L-15965	
				10. Work Unit No.	
9. Performing Organization Name and Address NASA Langley Research Center Hampton, VA 23665-5225				11. Contract or Grant No.	
				13. Type of Report and Period Covered Technical Paper	
12. Sponsoring Agency Name and Address National Aeronautics and Space Administration Washington, DC 20546-0001				14. Sponsoring Agency Code	
15. Supplementary Notes Allan J. Zuckerwar: Langley Research Center, Hampton, Virginia. David S. Mazel: Old Dominion University, Norfolk, Virginia.					
16. Abstract The sound speed in liquid oxygen (LOX), liquid nitrogen (LN ₂), and five LOX-LN ₂ mixtures was measured by an ultrasonic pulse-echo technique at temperatures in the vicinity of -195.8°C, the boiling point of N ₂ at a pressure of 1 atm. Under these conditions, the measurements yield the following relationship between sound speed <i>c</i> in meters per second and LN ₂ content <i>M</i> in mole percent: $c = 1009.05 - 1.8275M + 0.0026507M^2$. The sound speeds of 1009.05 m/sec ± 0.25 percent for pure LOX and 852.8 m/sec ± 0.32 percent for pure LN ₂ are compared with those reported by past investigators. Measurement of sound speed should prove an effective means for monitoring the contamination of LOX by LN ₂ .					
17. Key Words (Suggested by Authors(s)) Sound speed Liquid oxygen Liquid nitrogen Liquid oxygen contamination			18. Distribution Statement Unclassified—Unlimited Subject Categories 28, 71		
19. Security Classif.(of this report) Unclassified		20. Security Classif.(of this page) Unclassified		21. No. of Pages 20	22. Price A02

**National Aeronautics and
Space Administration
Code NIT-3**

**Washington, D.C.
20546-0001**

Official Business
Penalty for Private Use, \$300

**BULK RATE
POSTAGE & FEES PAID
NASA Washington, DC
Permit No. G-27**

NASA

**POSTMASTER: If Undeliverable (Section 158
Postal Manual) Do Not Return**
