

HE 4.6-15

MICROPROCESSOR -BASED SINGLE PARTICLE CALIBRATION OF SCINTILLATION COUNTER

MAZUMDAR G.K.D. & PATHAK K.M.
Department of Physics, Gauhati University
Gauhati -781014, ASSAM, INDIA

ABSTRACT

A microprocessor-based set-up is fabricated and tested for the single particle calibration of the plastic scintillator. The single particle response of the scintillator is digitized by an A/D converter, and a 8085 A based microprocessor stores the pulse heights. The digitized informations are printed with a printer. Facilities for CRT display and cassette storing and recalling are also made available.

The details of fabrication along with some results are presented in this paper.

1. Introduction. The system described here is designed to calibrate the plastic scintillators used in an EAS array in Gauhati University, Assam. The different aspects and significance of the study are already reported elsewhere (1). In this paper the design and the experimental set-up relating to the detection and recording of the scintillator responses due to single muons are reported.

2. Methods. Fig. 1 shows the experimental set-up for the calibration of the scintillators.

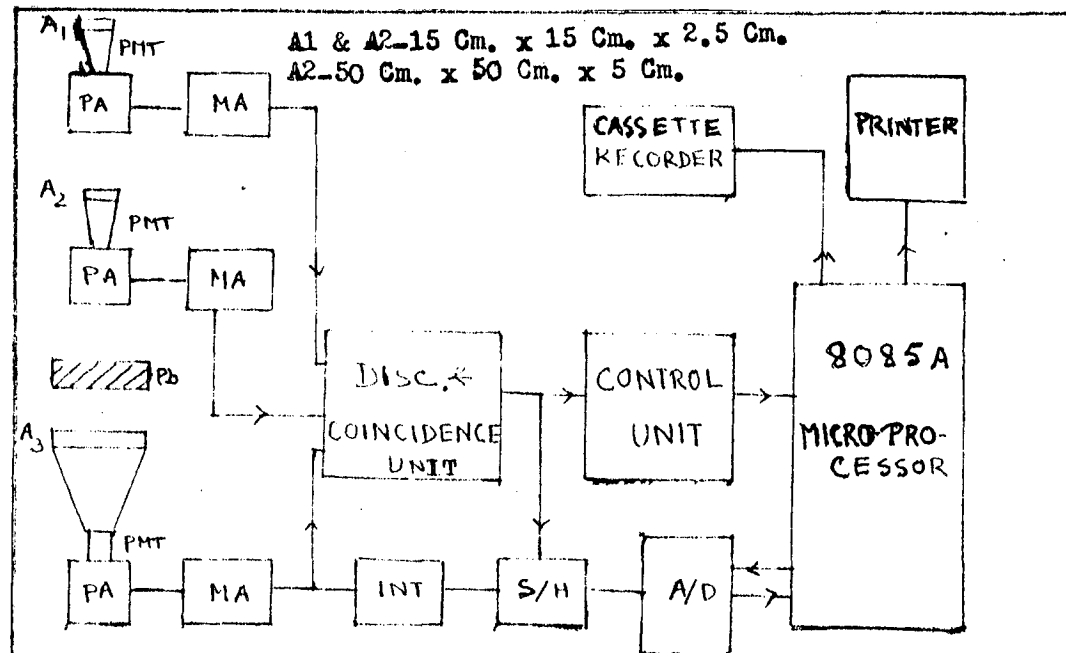

Fig.1:- The Experimental set-up .

It consists of three plastic scintillators A1, A2, & A3. The Scintillator A3 which is to be calibrated, is placed under a 20 Cm. thick lead block. Each scintillator is viewed by a 6364 PMT of 12.5 Cm. diameter.

The analog signals from each PMT are taken out from an inverting pre-amplifier (PA) fabricated using a MOSFET 2N 200 and two HF transistors BF115. The details of the amplifier system including sample-and-hold are reported elsewhere (2).

The output from the PA is input to the main amplifier (MA) by low loss cables. The MA output is integrated by an integrator (INT) and the integrated signal is sampled and held by a sample-and-hold (S/H) consisting of two LF 398 and 74 series TTL circuits. The S/H is actuated by a logic step derived from the Discriminator & coincidence unit. This unit comprises of three discriminators using Three 710 & one CD 4068. This unit is triggered by the MA output. The analog output of the S/H is digitized by an A/D converter 0816 and is controlled by a 8085 A microprocessor.

The microprocessor controls the detection and recording of the events.

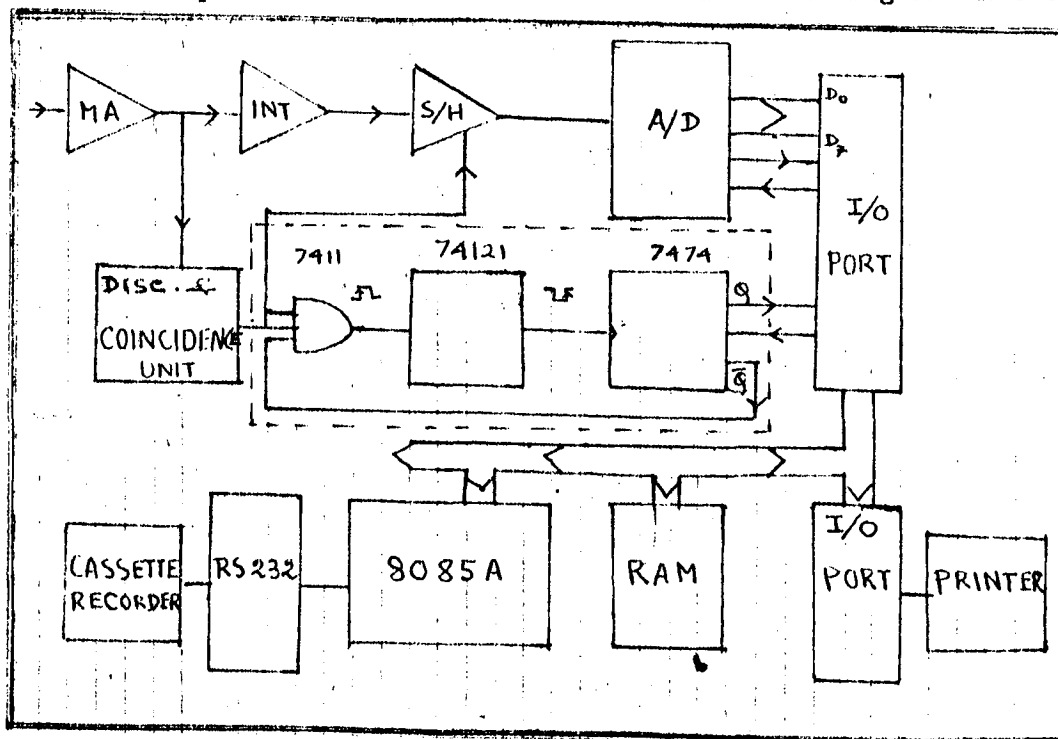

Fig. 2 Block Diagram of A/D conversion & recording electronics.

The electronics of the conversion & storing are shown in fig.2.

When A1, A2, and A3 are traversed by a vertical muon, the coincidence pulse is generated. On receipt of the coincidence pulse, the S/H holds the input analog signal and at the same time a positive pulse is generated by the AND gate 7411 of the control unit. The rising edge of this pulse triggers a monoshot 74121 to give a negative pulse at the output.

This pulse is connected to the clock input of the flipflop (F/F) 7474 and Q and \bar{Q} are set to high and low states respectively. Q is connected to the other input of the AND gate and it does not give any pulse till Q is reset to high state.

The high output of the F/F interrupts the microprocessor and it sends a start conversion pulse to the A/D. The 8-bit data bus of the A/D is coupled to the one of the I/O ports of the processor. The microprocessor sends a clear pulse after storing the digitized information in a RAM and it resets the F/F to be ready for the next event.

With the help of another port, the stored informations are printed out. The interface RS 232 is provided for cassette recording / CRT display.

3. Results & Discussion. Fig. 3 shows the pulse height distribution obtained with the present set-up. The most probable pulse height for single porticle is found to be $0.45 \pm .05$ Volts.

The number of electrons collected at the anode of the PMT is calculated using the relation $Q = NPM$ where N is the number of photon produced by the incident particle of energy E which dissipates dE energy in scintillator. P is photon transfer efficiency. M - over all gain of the PMT. Q is also calculated from the most probable pulse height and it is found to tally with the theoretical value within experimental error.

The response of the scintillator over different regions is also studied and is found to have variation less than 10% with a slight decrease towards the edge.

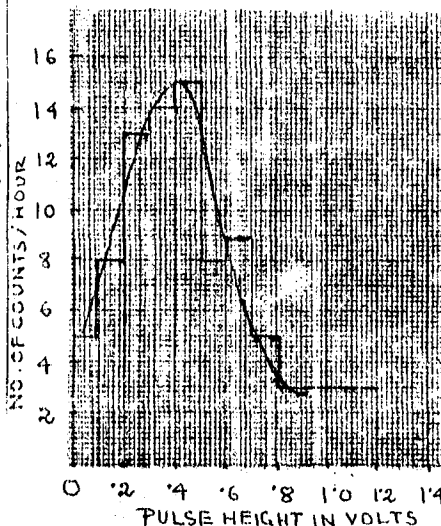

Fig. 3 Pulse height distribution

4. Conclusions. The technique developed has been used in estimating the number density in an air shower array for studying emission of EM waves from EAS.

The method, which can be very well used in place of an expensive Multichannel-Pulse-height-analyser (MCPHA), is useful for small laboratories.

5. Acknowledgements. The authors thank the Department Atomic Energy (BRNS), Govt. India for funding the project, and the TIFR, Bombay for some equipments. They also like to thank the Institute of Advance Studies in Science and Technology (Assam Science Society) for partial funding of the project.

References

1. Pathak K.M. et al (1982) Proc. of the International Workshop on V.H.E.G. R. Astronomy 309.
2. Mazumdar G.K.D. et al (1982) Proc. XVIII ICRC T 8 204.