

A Mini-array for Large Air Showers

L.K. Ng and S.K. Chan
Physics Department, University of Hong Kong
Hong Kong

W. Hazen and E. Hazen
Physics Department, University of Michigan
U.S.A.

Abstract

A mini-array that utilizes the Linsley effect is proposed for the measurement of large air showers. An estimate of the detectable shower rates for various shower sizes is made. Details of the detection and data collection systems are also described.

1. Introduction. Interest in the measurement of large air showers has been enhanced by the conflicting result reported in 1982 (Yakutsk¹). However, since intensities of large air showers are extremely low and only a few large centres are able to do the measurement, it was proposed by J. Linsley² that more independent measurements could be done with rooftop mini-arrays by making use of the particle arrival time distributions (Linsley effect). This idea has been pursued by us, and the present proposed system is the result after looking into various problems associated with such mini-arrays.

2. Theoretical estimation. To be able to measure the arrival time distribution, at least two particles per event are required. With a mini-array of 2 m^2 , a threshold density of the shower particles arriving at this mini-array should be $\rho_1 = 1 \text{ m}^{-2}$. Using the differential intensity expression,

$$j(N, \theta) = j(N) \cos^{\alpha} \theta ,$$

with $\alpha = 8.6$ at sea level, the shower rate for large showers with size N to $N + \delta N$ should be

$$\begin{aligned} \phi(N) \delta N &= 2\pi j(N) A(N) \delta N \int_0^{\pi/2} \cos^{\alpha+1} \theta \sin \theta d\theta \\ &= \frac{2\pi}{\alpha+2} j(N) A(N) \delta N, \end{aligned}$$

where $A(N)$ is the area containing the cores of all the air showers detected by the mini-array. Hence the integral shower rate is

$$\phi(>N_{\min}) = \frac{2\pi}{\alpha+2} \int_{N_{\min}}^{\infty} j(N) A(N) dN.$$

The area $A(N)$ is an annular ring with its outer radius determined by the density threshold $\rho_1 = 1 \text{ m}^{-2}$ and its inner radius determined by the minimum time spread σ_1 selected. Therefore, it has the form,

$$A(N) = \pi \left[\left(\frac{CN}{\rho_1} \right)^{2/n} - \left(\frac{\sigma_1}{B} \right)^{2/\beta} \right]$$

Hillas' integral intensity spectrum³,

$$J(>N) = 8.10^{-12} (N/10^8)^{-1.7} \text{ m}^{-2} \text{ sr}^{-1} \text{ s}^{-1}$$

is used to determine $j(N)$, and Linsley's empirical formula²,

$$\sigma(\text{ns}) = 2.6 \left(\frac{r}{30} + 1 \right)^{1.5} \text{ with } r \text{ in m}$$

is used to relate the time spread σ to the core distance r from the mini-array. The lateral distribution of electrons at Akeno⁴ for large showers,

$$\rho = 5.10^{-5} N (r/r_0)^{-3.8} \text{ with } r_0 = 79 \text{ m}$$

is used to relate ρ to r .

The final expression for the shower rate is given by

$$\phi(>\sigma_1, >\rho_1) = 9.07 \cdot 10^6 \rho_1^{-1.7} \sigma_1^{-2.97} \text{ day}^{-1},$$

and the values are tabulated below.

$\rho_1(\text{m}^{-2})$	$\sigma_1(\text{ns})$	N_{\min}	Shower rate (day^{-1})
1	50	$9.07 \cdot 10^5$	81.6
1	100	$6.25 \cdot 10^6$	10.4
1	200	$3.04 \cdot 10^7$	1.33
1	300	$8.49 \cdot 10^7$	0.40
1	400	$1.76 \cdot 10^8$	0.17

Table I

3. Detection system. From the estimation given in Table I, it is clear that a mini-array so constructed should be able to pick out the very few large air shower events from a swarm of irrelevant events including the counter noises, the background soft radiations and the small air showers. Fast electronics is also required for the determination and collection of the arrival time spread.

In order to eliminate the large number of small air showers, a minimum time spread σ_1 has to be assigned. According to Table I, for a mini-array of 2 m^2 , a minimum acceptable shower size of $9.07 \cdot 10^5$ requires a minimum time spread σ_1 equal to 50 ns.

A mini-array of 2 m² is then assembled which consists of 8 pieces of plastic scintillators each with dimensions 0.5m x 0.5m x 0.05m. In view of the small particle density encountered, each scintillator is not expected to receive more than one particle at a time from a shower.

Each scintillator is viewed by two 5" photomultipliers, the signal coincidence of which practically eliminates all the counter noises. In order to exclude the background soft radiations, the array is shielded by thin sheets of galvanized iron (0.5mm thick). Particle track identification may be found necessary at a later stage to ascertain genuine large shower events. This can be done by sandwiching the array by 4 layers of small diameter proportional counters.

The mini-array is placed in another small air shower array system, which may provide additional information on the nature of showers received.

4. Fast electronics. Precise measurement of the particle arrival time is essential in this experiment, and hence an anti-jitter preamplifier per counter is employed to remove the time jitter between the particle arrival time and the signal output time. The preamplifier as shown in figure 1 is a slightly modified version of the circuit described in another paper (HE 4.7 - 9), and the modification provides another coincidence input from a second photomultiplier.

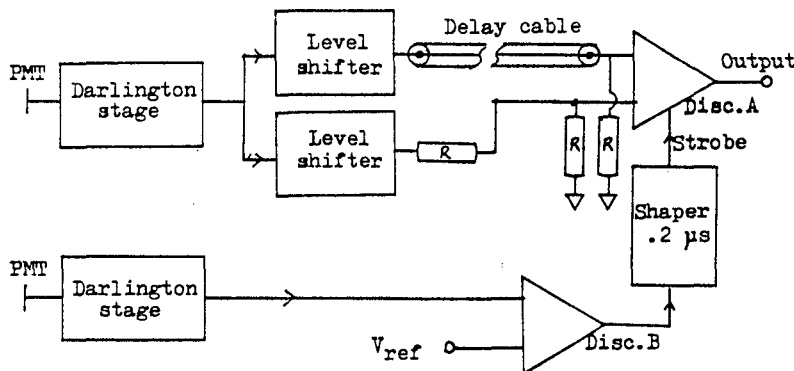
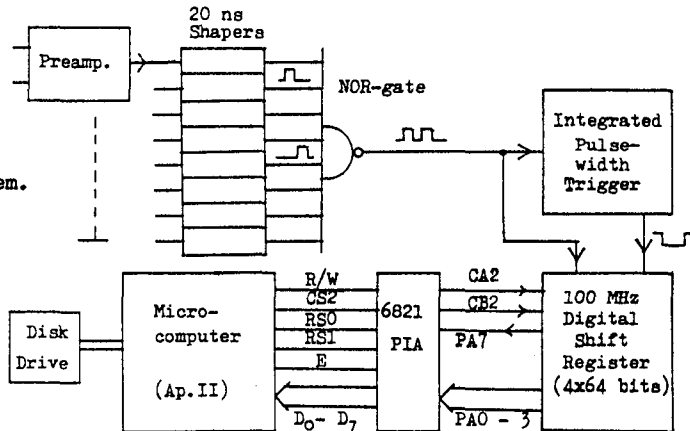

Fig. 1 Counter preamplifier.

Outputs from the eight counter preamplifiers are individually shaped to narrow pulses of 20 ns each, and then combined together to give a train of narrow pulses per shower. The time delay in each of the 8 channels from the particle arrival to the pulse output after combination has been equalized by adjusting the length of the delay cable in each preamplifier. The number of pulses in the train depends on the number of counters giving out particle signals, and the relative positions of the pulses in the train depend on their particle arrival time. The circuit block diagram is given in figure 2.

Fig. 2 The electronic system.



The pulse train is temporarily stored in a set of four shift registers. The shift registers have 4×64 bits in total and hence can readily store $2 \mu\text{s}$ of information. The clock rate for accepting the pulse train is equivalent to 100 MHz . Consequently, it provides a time resolution of 10 ns in the measurement of particle arrival time.

The criteria for recording a pulse train temporarily stored in the shift registers are (i) at least two pulses are found in the train, and (ii) the time spread of the pulses should not be less than σ_1 . Criterion (i) is dealt with by means an integrated pulse-width trigger circuit. Its basic element is given in figure 3. The charge accumulated in the capacitor C is proportional to the number of pulses in the train. A trigger pulse can be produced from the circuit at a pre-selected discrimination level. The trigger pulse then transfers data to the microcomputer shown in figure 2. Criterion (ii) is conveniently handled by software means after the data is read into the microcomputer.

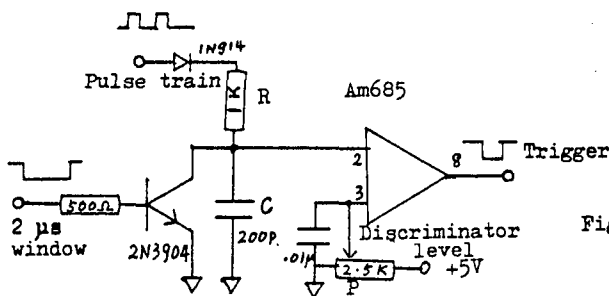

Fig.3 The integrator.

The above system has been assembled and thoroughly tested.

Reference.

1. Diminstein O S et al, 8th Eur.Cosmic-ray Symp. (Rome), 1982
2. Linsley J, (preprint).
3. Hillas A M et al, Phys. Reports, 20C (1975) 79.
4. Hara T et al, Proc. 18th ICRC (Bangalore), 11 (1983) 276.