

ACOUSTIC DETECTION OF AIR SHOWER CORES

Gao Xiaoyu
Physics Dept. Yunnan University, Kunming, Yunnan, P.R.C.
Liu Yongyue
Institute of High Energy Physics, Beijing, P.R.C.
Du Songlin
Physics Dept. Yunnan University, Kunming, Yunnan, P.R.C.

ABSTRACT

At an altitude of 1890m, a pre-test with an As core selector and a small acoustic array set up in an anechoic pool with a volume of $20 \times 7 \times 7 \text{m}^3$ was performed, beginning from Aug. 1984. In analysing the waveforms recorded during the effective working time of 186 hrs, three acoustic signals which can not be explained as from any sources other than AS cores were obtained and the estimation of connective parameters was made.

1. Introduction. Up to now, the only way of studying VH energy phenomena is by means of air shower. But, as the AS energy becomes higher and higher, the sensitive area needed to detect it becomes larger and larger. Limited finances make it difficult to perform the experiment. The suggested scheme of acoustic detection of AS cores (1) (2) will be not only less costly, but also able to determine the core energy and the accurate position at which the high transverse momentum may be shown. And furthermore, some topics associated with astrophysics can be studied by determining the directions along which AS's arrive. The experiments on acoustic signals caused by proton beams (3) have proved it is feasible to detect acoustic signals caused by high energy particles passing through water. Our preceding work (4), in which the influences of the duration of heating pulses and of the transient responses of hydrophones on the time structures and the amplitudes of acoustic pulses were studied in particular, indicated that the energy threshold of the acoustic detection calculated from the data of accelerator experiments, without taking into account the effect of spill time of the proton beam, was much too high. However, the acoustic signals are still weak because of the very small energy transformation ratio (10^{-9} - 10^{-10}). The low S/N ratio has been remaining the main difficulty in the application of the acoustic detection. Particularly, in a natural water body (such as an ocean or a lake) background noises from the surface conditions (wind, waves, boats) and from animal life will greatly reduce the S/N ratio. In order to accumulate experiences for designing a largescale acoustic detector, the pre-test was performed with an anechoic pool whose background noises were very low.

2. Methods. The experiment arrangement is schematically shown in Fig. 1. The AS core selector, which consisted of four counters with active area of 0.33m^2 each set up on the corners of the pool, was arranged to select $E > 10^{25}$ ev events.

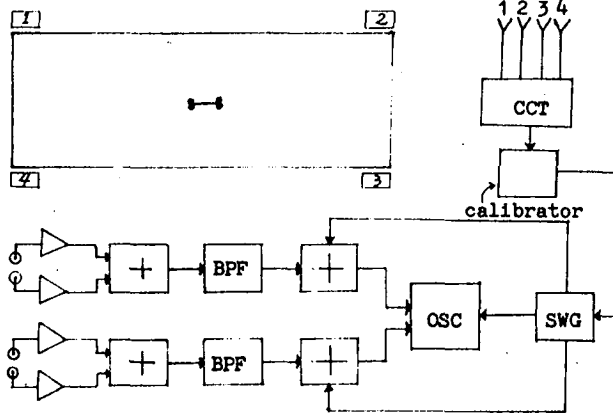

Fig. 1 Schematic of experimental arrangement and electronics.

When there was a fourfold coincidence pulse coming out of AS core selector, the fourstep staircase wave generator was triggered once and produced three simultaneous outputs. One of the outputs was used to trigger the double-beam oscilloscope and the other two were fed respectively to the

two signal channels so as to increase the effective breadth of the screen by four times. The sweep speed of the oscilloscope was 0.2ms/cm , so that about two and a half timebase lines were enough to display the events happening at any spot in the pool, and the rest part of timebase lines which had no information relative to AS cores on it was used for comparison.

The four PZT-5 spherical hydrophones used in the experiment are essentially the same, and their frequency response are flat up to 50 KHz. In each signal channel, acoustic signals with the same phase coming from the two hydrophones set up very closely together were amplified and then added together to improve the signal-to-electric-noise ratio. The output terminals of the two signal channels were connected respectively to the two input terminals of the oscilloscope.

According to the most probable spectrum distribution of signal and the influence of the response of hydrophones on the time structures of acoustic signal and the consideration on minimum BW with tolerable distortion, we employed filters with a pass-band of 3KHz to 30KHz to limit noises as much as possible. It was shown by our simulating experiment with Q-switch laser beams that these filters did not cause serious distortion. The anechoic pool used in the experiment had low background noises. Fig. 2 shows the noise spectrum for the whole detection system (including ambient

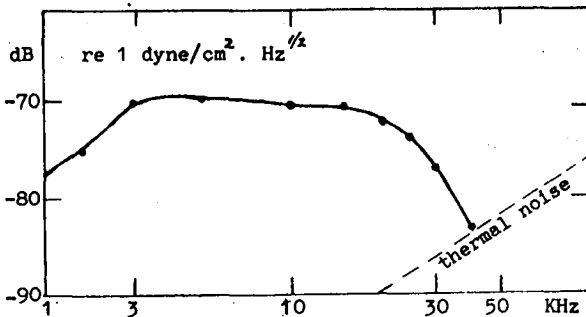

Fig. 2 Noise spectrum for whole detection system.

noise, noises of hydrophones and amplifiers), the noise

lever is $1.5 \times 10^{-4} \mu\text{b}/\text{Hz}^{\frac{1}{2}}$ at a frequency of 30KHz. The water temperature was 18.5°C during the experiment.

3. Results and Discussion. In sweeping and analysing all of the traces recorded during the effective working time of 186 hr. The acoustic signals of three events which had the following characteristics in common were obtained.

1. The signals from the two channels are both bipolar pulses and have the same shape except the amplitudes.

The calculation (5) from thermoacoustic model and the experiments (3) (4) with proton beams and laser beams have shown that when a beam of charged particles passes through water, the acoustic signal caused by the sudden thermal expansion of water is a bipolar pulse. AS cores produce this type of event.

2. The positions at which the signal pulses appear on the timebase lines, which are determined by the propagation times of the sound wave from the source to the hydrophones in water, are accordant with the geometrical configuration of the pool and the location of hydrophones in it.

3. The attenuation of the signals obeys the propagation law of the cylindrical wave, i.e. $p \propto 1/\sqrt{R}$.

Fig.3 Gives the copy of event acoustic signal No. KY 3.

The three characteristics mentioned above are only the necessary requirements that acoustic signals caused by AS cores must satisfy. On the other hand, the possibilities that the same results may be caused by other factors have to be considered and eliminated one by one.

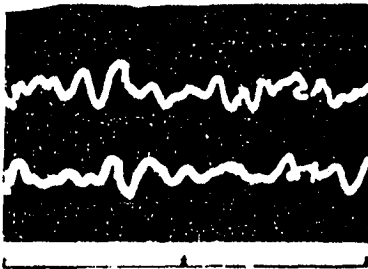

Fig.3 The copy of event acoustic signal No. KY 3. Scale is $200\mu\text{s}/\text{cm}$.

(a) If any electric interference was picked up, its waveforms from the two signal channels would appear at exactly the same position on the corresponding timebase lines. We did see these waveforms. But it was very easy to identify and ignore them. One kind of interference which must be considered is the noises from the electric equipment themselves. After they had worked continuously for

3hr., we short-circuited their inputs and observed the noise waveforms, it was seen that a large number of which were unipolar pulses emerging at random. No bipolar pulses were observed.

(b) If any acoustic disturbance was received by the hydrophones, its waveforms would be of damped oscillation form but bipolar pulses in general. Even if bipolar pulses had appeared, their amplitudes would not have varied as $1/\sqrt{R}$ as required in the near field configuration. We did not find any

possibility in the existence of a cylindrical source besides AS cores in the pool.

(c) If any other interferences were present, no matter at regular time or at random their waveforms would appear on every timebase line with the same probability, because the oscilloscope was triggered by the coincidence output of the AS core selector which occurred at random. In order to obtain sufficient record of the background noises, we triggered the oscilloscope manually at various intervals between different stages of the experiment and all of the timebase lines obtained had no information from AS cores on it, (we call them background lines). The number of all background lines (including the last one and a half lines obtained when the oscilloscope was triggered by the coincidence output of the AS core selector) were larger than that of the lines information on it. But no signals whose characteristics are the same as any one of the three event signals appear on the background lines. Therefore this kind of possibility can be eliminated.

From about, the three acoustic signals can not be explained as from any sources other than AS cores. The experiment date are listed in the following table in which the subscripts 1 and 2 indicate channels one and two respectively. From the table, it is can be seen that the values of the effective diameter of the cores causing acoustic effect are not inconsistent with the expected ones.

Event	$t(\mu s)$	$P_1(\mu b)$	$P_2(\mu b)$	$d(cm)$	$f_c(KHz)$	P_2/P_1	$\sqrt{R_1}/\sqrt{R_2}$
KY 1	50	0.23	0.37	7.5	20	1.66	1.64
KY 2	30	0.31	0.36	4.5	33	1.16	1.13
KY 3	40	0.24	0.25	6.0	25	1.06	1.02

Key: t — Duration of acoustic pressure pulse

P — Acoustic pressure

d — Effective diameter

f — mid-frequency

R — Distance from source to hydrophones

4. Acknowledgments. We would like to thank Prof. Yan Guigong (Yunnan University) for his encouragement and Engineer Jiang Weiluan, Gong Wending, Associate Engineer Huang Aiyong and Wong Liyan for their helps with this experiment.

References

1. Bowen, T. et. al., "A lake Detection for High Energy Air Shower Near the Fly's Eye" Proc. of Air Shower Workshop, 1979.
2. Liu Yongyue, Gao Xiaoyu, (1981), Physics (Chinese), 10, p690.
3. Sulak, L., et. al., (1979), Nuci. Inst. & Meth. 161, p203.
4. Gao Xiaoyu, Liu Yongyue, (1983), 18th ICRC, 8, p166.
5. Bweb, T. (1977), 15th ICRC, p277.