

NASA Technical Memorandum 87114

Measurement of the Density of Base Fluids at Pressures to 2.2 GPa

Bernard J. Hamrock
Lewis Research Center
Cleveland, Ohio

and

Bo O. Jacobson and Sten-Ivar Bergström
University of Luleå
Luleå, Sweden

(NASA-TM-87114) MEASUREMENT OF THE DENSITY
OF BASE FLUIDS AT PRESSURES 0.422 TO 2.20
GPa (NASA) 22 p HC A02/MF A01 CSCL 20D

N86-10551

G3/37 Unclas
27498

Prepared for the
Annual Meeting of the American Society of
Lubrication Engineers
Toronto, Canada, May 12-15, 1986

NASA



MEASUREMENT OF THE DENSITY OF BASE FLUIDS AT PRESSURES TO 2.20 GPa

Bernard J. Hamrock
National Aeronautics and Space Administration
Lewis Research Center
Cleveland, Ohio 44135

Bo O. Jacobson and Sten-Ivar Bergström
University of Luleå,
Luleå, Sweden

Abstract

The influence of pressure on the density of six base fluids was experimentally studied for a range of pressures from 0.422 to 2.20 GPa. An important parameter used to describe the results is the change in relative volume with change in pressure dv_r/dp . For pressures less than the solidification pressure ($p < p_s$) a small change in pressure resulted in a large change in dv_r/dp . For pressures greater than the solidification pressure ($p > p_s$) there was no change in dv_r/dp with changing pressure. The solidification pressures of the base fluids varied considerably, as did the slopes that the experimental data assumed for $p < p_s$. A new formula was developed that describes the effect of pressure on density in terms of four constants. These constants vary for the different base fluids tested.

SYMBOLS

$$C = 1 + mp_1^2/2 + (n_2 - mp_s)p_1$$

$$C_1 = m/2C, (\text{GPa})^{-2}$$

$$C_2 = (n_2 - mp_s)/C, (\text{GPa})^{-1}$$

$$C_3 = n_2/C, (\text{GPa})^{-1}$$

$$C_4 = mp_s^2/2C$$

M mass of fluid, kg

m slope, $(\text{GPa})^{-2}$

n_1 intercept, $(\text{GPa})^{-1}$

n_2 asymptote, $(\text{GPa})^{-1}$

- p pressure, GPa
 p_s solidification pressure, GPa
 p_i initial pressure, GPa
 v volume of lubricant, m^3
 v_i initial volume of lubricant, m^3
 v_r relative volume, v/v_i
 ρ density, kg/m^3
 ρ_0 atmospheric density, kg/m^3
 $\bar{\rho}$ dimensionless density, ρ/ρ_0

INTRODUCTION

One of the properties that is characteristic of every material is its density. It is defined as

$$\rho = M/v \quad (1)$$

where

- M mass of lubricant, kg
 v volume, m^3

In a lubricant or base fluid, for a comparable change in pressure, the density change is small compared with the viscosity change. However, at the very high pressures existing in elastohydrodynamic lubricating films, the liquid can no longer be considered as an incompressible medium. It is therefore necessary to consider the dependence of the density on pressure.

The variation of the density of liquids with pressure has been studied by a number of investigators. P.W. Bridgman already in 1949 compressed hydrocarbon liquids at pressures to 3 GPa. In his experiments Bridgman (1949) measured the static equilibrium conditions; he determined the solidification of the fluids by the decrease of volume at the constant solidification pressure. In lubrication situations the rate of pressure increase is very

high, typically 10^{13} Pa/s. The lubricant will not have time to crystallize but will be compressed to an amorphous solid.

The density of lubricating oils used in elastohydrodynamically lubricated contacts has been described by the following relationship:

$$\bar{\rho} = \rho/\rho_0 = 1 + 0.6 p/(1 + 1.7 p) \quad (2)$$

where p is expressed in gigapascals. Equation (2) was obtained from Dowson and Higginson (1966). This equation states that the variation of density with pressure is roughly linear at low pressures but that its rate of increase falls off at high pressures. The maximum density increase from atmospheric pressure is 35 percent. The data used in obtaining Eq. (2) were restricted to relatively low pressures (<0.40 GPa).

In the present investigation the density of six base fluids was measured for the pressure range 0.422 to 2.20 GPa. The data were then curve fitted, and an expression for density as a function of pressure was established for these base fluids. The existing and the newly developed formulas are compared. Because nonconformal contacts such as rolling-element bearings and gears operate in the range 1 to 3 GPa, it is important to know how density varies at these pressures.

APPARATUS

The apparatus used to measure the effect of pressure on the density of the fluids is shown in Fig. 1. It is essentially the same apparatus used by Höglund (1984) and Höglund and Jacobson (1985) to evaluate the relationship between limiting shear strength and pressure for lubricants. This apparatus can reach pressures of 2.20 GPa and temperatures of 200 °C. Some of the important parts of the apparatus are described herein, and more details can be found in either Höglund (1984) or Höglund and Jacobson (1985).

Plungers - The plungers are made of sintered carbide (89 wt % WC and 11 wt % Co). The compression strength is 4600 MPa, Young's modulus is 575 GPa, and Poisson's ratio is 0.22. The overall length of a plunger is 88 mm. A tolerance on the surface roughness of the plungers is 1 μm rms on all surfaces.

Hollow Circular Cylinders - The cylinder is 50 mm high and is made of two parts, an outer cylinder and an inner cylinder. The outer cylinder, with a diameter of 180 mm, is made of high-quality steel. The inner cylinder, with a diameter of 33 mm, is shrunk fitted to the outer cylinder and made of the same material as the plungers, sintered carbide. The central hole of the inner cylinder has a diameter of 10 mm. The radial clearance between the plunger and the inner cylinder is 3.5 μm .

Seals - To prevent the pressurized fluid in the cylinder from leaking out, a seal is located between the plunger and the hole in the cylinder. The seal is made of the same material as the outer circular cylinder (high-quality steel). The surface roughness of the seal is 0.25 μm rms.

Hydrostatic Bearings - Each plunger is mounted in a conical seat in a hydrostatic bearing. The bearing helps to compensate for misalignment between plunger and cylinder and also allows the plunger to be rotated about its axis with a very low coefficient of friction. The hydrostatic bearings are made of ordinary steel (0.35 wt % C, 0.18 wt % Si, and 0.40 wt % Mn). The contact stress between the plunger and its hydrostatic seat is 730 MPa at the maximum pressure in the cylinder of 2.20 GPa. The roughness of the mating surfaces of the hydrostatic bearings is 1 μm rms.

Frame - The main parts of the frame are two steel plates and four columns. The steel plates have outer dimensions of 350 by 350 mm and are each 50 mm thick. In each corner of each plate is a hole at a radius of 177 mm. These holes have a diameter of 30 mm except at the facing surface of each plate,

where the holes widen to a depth of 4 mm. The upper steel plate has a threaded hole in the center in which the hydraulic jack is mounted. The lower plate has an equivalent threaded hole, M30X2, in which the lower hydrostatic bearing is mounted.

The columns are made of steel and have a diameter of 35 mm and an overall length of 550 mm. At the end of each column the diameter is decreased to 30 mm for a total length of 80 mm of which the last 60 mm is threaded. The columns fit closely into four holes in the steel plates and are locked by the nuts on the back of the plates.

Hydraulic Jack - A hydraulic jack is mounted in the threaded hole in the center of the upper steel plate of the frame. It is used to raise and lower the upper hydrostatic bearing with the plunger and to create the force needed to compress the fluid. The jack is hand operated and is designed for pressures to 80 MPa, corresponding to a maximum force of 2.6×10^5 N. The normal operating pressures of 0 to 52 MPa give a pressure within the inner cylinder of 0 to 2200 MPa. The pressure in the hydraulic jack has been measured with a precision pressure gauge and calibrated to an accuracy of ± 0.1 MPa. The time for compressing the fluid from zero pressure to 2200 MPa was about 2 sec.

TEST PROCEDURE

The upper plunger was mounted in the upper hydrostatic bearing. The thin plates holding the hollow cylinder were moved upward. The lower plunger was then fitted into the conical groove in the lower bearing, and the threaded plunger-holder was screwed into the bearing. The holder was not tightened, so that the plunger was free to move a few millimeters up and down. The wires from the thermocouple were connected to the voltmeter. The seals between the plungers and the cylinder hole were then inserted about 2 mm into the hole from each side. The thin steel plates holding the cylinder were slowly lowered until the lower plunger was fitted into the cylinder hole. At the same time

the plunger was held above the conical seat and manually inserted into the cylinder hole. In this way there was no risk of jamming the plunger between the bearing and the cylinder. After the plunger was fitted into the cylinder hole, it was inserted to a depth of 9 mm into the cylindrical part, not including the 8-mm-high cross-shaped upper part. The threaded plunger-holder was then tightened. The fluid to be tested, 2.5 cm³, was injected into the cylinder and left for some hours in order for possible air bubbles in the fluid to disappear. Any small bubbles remaining in the fluid would be dissolved when subjected to the high testing pressures.

The upper plunger was then lowered and fitted into the hole of the cylinder by the jack. The pressure was applied to the initial value of 0.422 GPa and kept constant for about 30 s, whereafter the distance between the hydrostatic bearings was measured accurately. This distance was used to calculate the volume of the compressed oil. The pressure was then increased in about 20 steps to 2.20 GPa. For each step the volume change and pressure were recorded after about 30 s, when the slight temperature change caused by the compression had disappeared. The distance the plungers moved during the compression of the fluid was measured by using a dial indicator with an error of <0.01 mm.

EXPERIMENTAL DATA

A wide range of unformulated lubricating fluids of different chemical characteristics was chosen so that more definite conclusions could be drawn from the results. Table 1 gives the lubricants, their kinematic viscosities at 40 °C in square millimeters per second and their average molecular weights.

All of the data presented in this paper are for a fixed temperature of 20 °C. An attempt to describe the effect of varying temperature on density was not fruitful.

By using the experimental apparatus the volume of fluid in the test chamber was established for various pressures. The volume was corrected for the elastic deformation of the walls of the test chamber. A finite-element elasticity computer program was used for these calculations. The initial pressure of all of the fluids in the test apparatus was chosen as 0.422 GPa. Below this pressure the accuracy of the results was questionable.

The effect of volume v on pressure was determined for the six base fluids as shown in Fig. 2. The volume-pressure relationship, although parabolic at lower pressures, became linear after a critical pressure p_s was reached. The critical pressure point changed for the different fluids and can be viewed as the solidification pressure or glass transition. The relative volume is defined as

$$v_r = v/v_1 \quad (3)$$

where v_1 is the initial volume (i.e., in this study the volume at 0.422 GPa). The effect of relative volume v_r on pressure was determined for the six base fluids as shown in Fig. 3. Just as was true for the volume-versus-pressure plots, the plot of relative volume versus pressure also contains two different regions: parabolic below p_s , and linear above p_s . Also plotted in Fig. 3 is the effect of relative volume as obtained from the Dowson and Higginson formula (Eq. (2)). By making use of Eq. (1), Eq. (2) can be rewritten as

$$(v_r)_{D-H} = \frac{1 + 0.6 p_1 / (1 + 1.7 p_1)}{1 + 0.6 p / (1 + 1.7 p)} \quad (4)$$

An important parameter developed in the present study is dv_r/dp , or the change in relative volume with change in pressure. This may be viewed as a stiffness parameter. The dimensional unit of dv_r/dp is gigapascals⁻¹. Figure 4 shows typical effects of p on $-dv_r/dp$ for the various base fluids tested. Up to a critical pressure p_s the relationship between dv_r/dp and p was linear with a steep negative slope. For pressures greater than p_s the

value of dv_r/dp was constant at the value n_2 . Physically this means that, as the base fluid was compressed, the distance between the molecules of the base fluid became smaller and smaller. Therefore at pressures less than p_s the molecules occupied a space larger than their molecular volume. The molecules were compressed and freedom of movement reduced as the pressure was increased. Finally a point was reached when the molecules were packed closely together and there was no change of dv_r/dp with p . Therefore at p_s the molecules have no freedom of movement, and any further compression will result in deformation of the molecules and can be described by dv_r/dp equal to a constant.

Figure 5 extends the general description of Fig. 4 to the six base fluids more specifically. The location of p_s varies with the different fluids, but the general form shown in Fig. 4 was preserved for all of the fluids. Although the slope of the line in the region $p < p_s$ differed for the various fluids, the level of dv_r/dp in the region $p > p_s$ did not vary significantly.

PRESSURE-DENSITY EQUATION

From Fig. 4 we can write the following general equations:

$$-dv_r/dp = mp + n_1 \quad \text{for } p \leq p_s \quad (5)$$

$$-dv_r/dp = n_2 \quad \text{for } p \geq p_s \quad (6)$$

where

m slope, $(\text{GPa})^{-2}$

n_1 intercept, $(\text{GPa})^{-1}$

n_2 asymptote, $(\text{GPa})^{-1}$

From Fig. 4 we can also write

$$m = (n_2 - n_1)/p_s \quad \text{or} \quad n_1 = n_2 - mp_s \quad (7)$$

Substituting this into Eq. (5) gives

$$-dv_r/dp = m(p - p_s) + n_2 \quad \text{for } p \leq p_s \quad (8)$$

Integrating Eq. (8) and making use of Eq. (1) gives

$$-\frac{1}{\bar{\rho}} \left(\frac{v_0}{v_1} \right) = m \frac{p^2}{2} + (n_2 - mp_s)p + A \quad (9)$$

Making use of the boundary condition that $p = 0$ and $\bar{\rho} = 1$ gives $A = -v_0/v_1$.

$$\bar{\rho} = \frac{\rho}{\rho_0} = \frac{1}{1 - \left(\frac{v_1}{v_0} \right) \left[\frac{mp^2}{2} + (n_2 - mp_s)p \right]} \quad \text{for } p \leq p_s \quad (10)$$

Integrating Eq. (6) and making use of the boundary condition that $p = p_s$ when $v = v_s$ gives

$$-\frac{v}{v_1} + \frac{v_s}{v_1} = n_2(p - p_s) \quad (11)$$

Making use of Eq. (1) gives

$$\bar{\rho} = \frac{\rho}{\rho_0} = \frac{1}{\frac{v_s}{v_0} - \frac{v_1}{v_0} n_2(p - p_s)} \quad \text{for } p \geq p_s \quad (12)$$

At the common boundary the density must be the same in Eqs. (10) and (12).

$$\frac{v_s}{v_0} = 1 - \left(\frac{v_1}{v_0} \right) \left(n_2 - \frac{m}{2} p_s \right) p_s \quad (13)$$

Substituting Eq. (13) into Eq. (12) gives

$$\bar{\rho} = \frac{\rho}{\rho_0} = \frac{1}{1 - \frac{v_1}{v_0} \left(n_2 p - \frac{m}{2} p_s^2 \right)} \quad \text{for } p \geq p_s \quad (14)$$

The term v_1/v_0 appearing in Eqs. (10) and (14) is an unwanted parameter.

From Eq. (10) we can write

$$\frac{v_1}{v_0} = \frac{1}{1 + \frac{m}{2} p_1^2 + (n_2 - mp_s)p_1} \quad (15)$$

Substituting Eq. (15) into Eqs. (10) and (14) gives

$$\bar{\rho} = \frac{1}{1 - \frac{mp^2/2 + (n_2 - mp_s)p}{1 + mp_1^2/2 + (n_2 - mp_s)p_1}} \quad \text{for } p \leq p_s \quad (16)$$

$$\bar{\rho} = \frac{1}{1 - \frac{n_2 p - mp_s^2/2}{1 + mp_1^2/2 + (n_2 - mp_s)p_1}} \quad \text{for } p \geq p_s \quad (17)$$

A least-squares method was used to obtain values of m , n_1 , n_2 , and p_s from the experimental data for each base fluid as shown in Table 2. Note that there was a significant variation in the slope m but not in the value of n_2 .

Equations (16) and (17) can be expressed more simply as

$$\bar{\rho} = \frac{1}{-C_1 p^2 - C_2 p} \quad \text{for } p \leq p_s \quad (18)$$

$$\bar{\rho} = \frac{1}{1 - C_3 p + C_4} \quad \text{for } p \geq p_s \quad (19)$$

where

$$C = \bar{\rho} + \left(\frac{m}{2}\right) p_1^2 + (n_2 - mp_s)p_1 \quad (20)$$

$$C_1 = m/2C, \quad (\text{GPa})^{-2} \quad (21)$$

$$C_2 = (n_2 - mp_s)/C, \quad (\text{GPa})^{-1} \quad (22)$$

$$C_3 = n_2/C, \quad (\text{GPa})^{-1} \quad (23)$$

$$C_4 = mp_s^2/2C \quad (24)$$

The values of C_1 , C_2 , C_3 , and C_4 are shown in Table 3 for the six base fluids tested.

Table 3 was used to obtain Fig. 6, which shows the effect of pressure on density for two of the fluids. Also in this figure is the pressure-density

curve obtained from Dowson and Higginson (1966). As the pressures increased above 2 GPa, the deviation between the Dowson and Higginson (1966) formula and the present results also increased. For pressures to 2 GPa for the naphthenic distillate, there was good agreement with the Dowson and Higginson (1966) formula. The same cannot be said for the poly alpha olefin. It is anticipated that these deviations from the normally used Dowson-Higginson pressure-density formula will significantly influence the definition of the pressure profile in elastohydrodynamically lubricated conjunctions.

Furthermore it can be observed from Fig. 6 that for fluids other than mineral oils the Dowson-Higginson (1966) formula (Eq. (1)) is not valid as demonstrated with poly alpha olefin. Therefore the claim is made that Eqs. (18) and (19) are valid for all kinds of fluids as long as there are measured values for the constants C_1 , C_2 , C_3 , and C_4 .

CONCLUSION

Experimental data have been obtained showing the effect of pressure on density for a range of pressures from 0.422 to 2.20 GPa. Six base fluids were tested at a constant temperature of 20 °C. An important parameter used to describe the results is the change in relative volume with change in pressure dv_r/dp . For pressures less than the solidification pressure ($p < p_s$), a small change in pressure resulted in a large change in dv_r/dp . For pressures greater than the solidification pressure ($p > p_s$), there was no change in dv_r/dp with changing pressure. Once the molecules of the lubricant became closely packed, increasing the pressure failed to alter the value of dv_r/dp . The solidification pressure varied considerably for the different base fluids. Furthermore for $p < p_s$ the experimental data assumed different slopes for the different base fluids. A new formula was developed that describes the effect of pressure on density in terms of four constants. These constants vary for the different base fluids. The new formula is valid not only for mineral

oils but for any type of lubricant. Furthermore since the pressure-density data were obtained for pressures to 2.20 GPa, the new pressure-density formula is valid for conditions normally experienced by nonconformal contacts like rolling-element bearings and gears.

ACKNOWLEDGMENTS

The authors would like to thank Måns Collin, Bertil Eriksson, and Per Redelius, all of AB Nynäs Petroleum, for their useful discussions of the results and for providing the authors with the base fluids that were used in the experiments.

REFERENCES

1. Bridgman, P.W., "Viscosities to 30,000 kg/sq. cm," Proc. Am. Acad. Arts Sci., 77, 117-146 (1949).
2. Dowson, D. and Higginson, G.R., Elastohydrodynamic Lubrication, The Fundamentals of Roller and Gear Lubrication, Pergamon, (1966).
3. Höglund, E., "Elastohydrodynamic Lubrication - Interferometric Measurements, Lubricant Rheology and Subsurface Stresses," Doctoral Dissertation, 320, Luleå University of Technology, Sweden (1984).
4. Höglund, E. and Jacobson, Å.O., "Experimental Investigation of Shear Strength of Lubricants Subjected to High Pressure and Temperature," a paper to be presented at ASME-ASLE Tribology Conference October 8-10, 1985, Atlanta, GA; to be later published in the ASME Journal of Tribology.

TABLE 1. - BASE FLUIDS TESTED, WITH
CORRESPONDING KINEMATIC VISCOSITY
AND AVERAGE MOLECULAR WEIGHT

| Base fluid | Kinematic viscosity, at 40 °C, (mm) ² /s | Average molecular weight |
|-----------------------|---|--------------------------|
| Naphthenic distillate | 26 | 300 |
| Naphthenic raffinate | 23 | 320 |
| Polypropylene glycol | 175 | 2000 |
| Polypropylene glycol | 80 | 1000 |
| Ditridecyl adipate | 26 | 510 |
| Poly alpha olefin | 450 | 500 |

TABLE 2. - PARAMETERS OBTAINED FROM LEAST-SQUARES FIT OF
EXPERIMENTAL DATA

| Base fluid | Slope, m, (GPa) ⁻² | Intercept, n ₁ , (GPa) ⁻¹ | Asymptote, n ₂ , (GPa) ⁻¹ | Solidification pressure, P _s , GPa |
|-----------------------|-------------------------------|---|---|---|
| Naphthenic distillate | -0.626 | 0.496 | 0.0538 | 0.706 |
| Naphthenic raffinate | -.336 | .336 | .0542 | .839 |
| Polypropylene glycol | -.271 | .332 | .0360 | 1.092 |
| Polypropylene glycol | -.195 | .276 | .0395 | 1.213 |
| Ditridecyl adipate | -.115 | .219 | .0395 | 1.561 |
| Poly alpha olefin | -.0958 | .205 | .0439 | 1.682 |

TABLE 3. - CONSTANTS USED IN DEFINING EFFECT OF PRESSURE ON DENSITY

| Base fluid | Pressure-density constants | | | |
|-----------------------|--------------------------------------|--------------------------------------|--------------------------------------|----------------|
| | C ₁ , (GPa) ⁻² | C ₂ , (GPa) ⁻¹ | C ₃ , (GPa) ⁻¹ | C ₄ |
| Naphthenic distillate | -0.271 | 0.430 | 0.0466 | -0.135 |
| Naphthenic raffinate | -.151 | .302 | .0487 | -.106 |
| Polypropylene glycol | -.121 | .297 | .0323 | -.145 |
| Polypropylene glycol | -.0887 | .251 | .0395 | -.131 |
| Ditridecyl adipate | -.0531 | .202 | .0365 | -.129 |
| Poly alpha olefin | -.0444 | .190 | .0407 | -.126 |

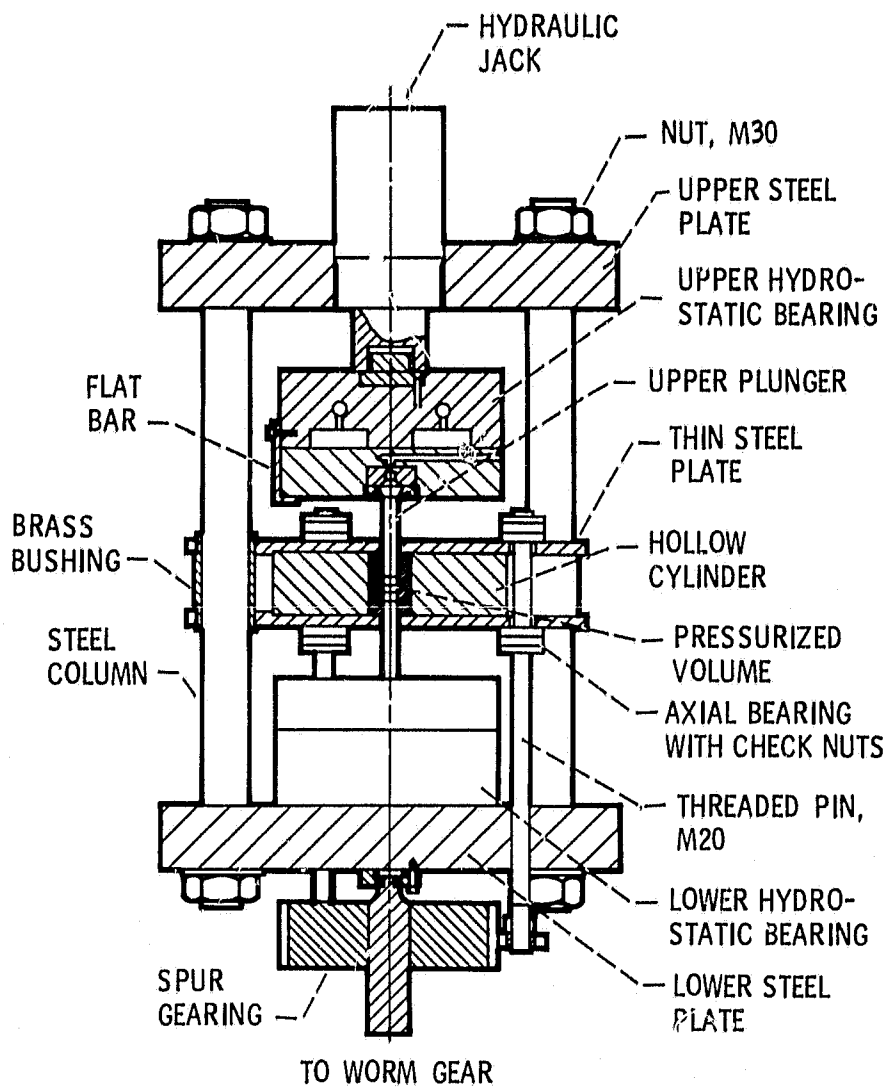

Fig. 1 Main parts of experimental apparatus. (From Höglund (1984).

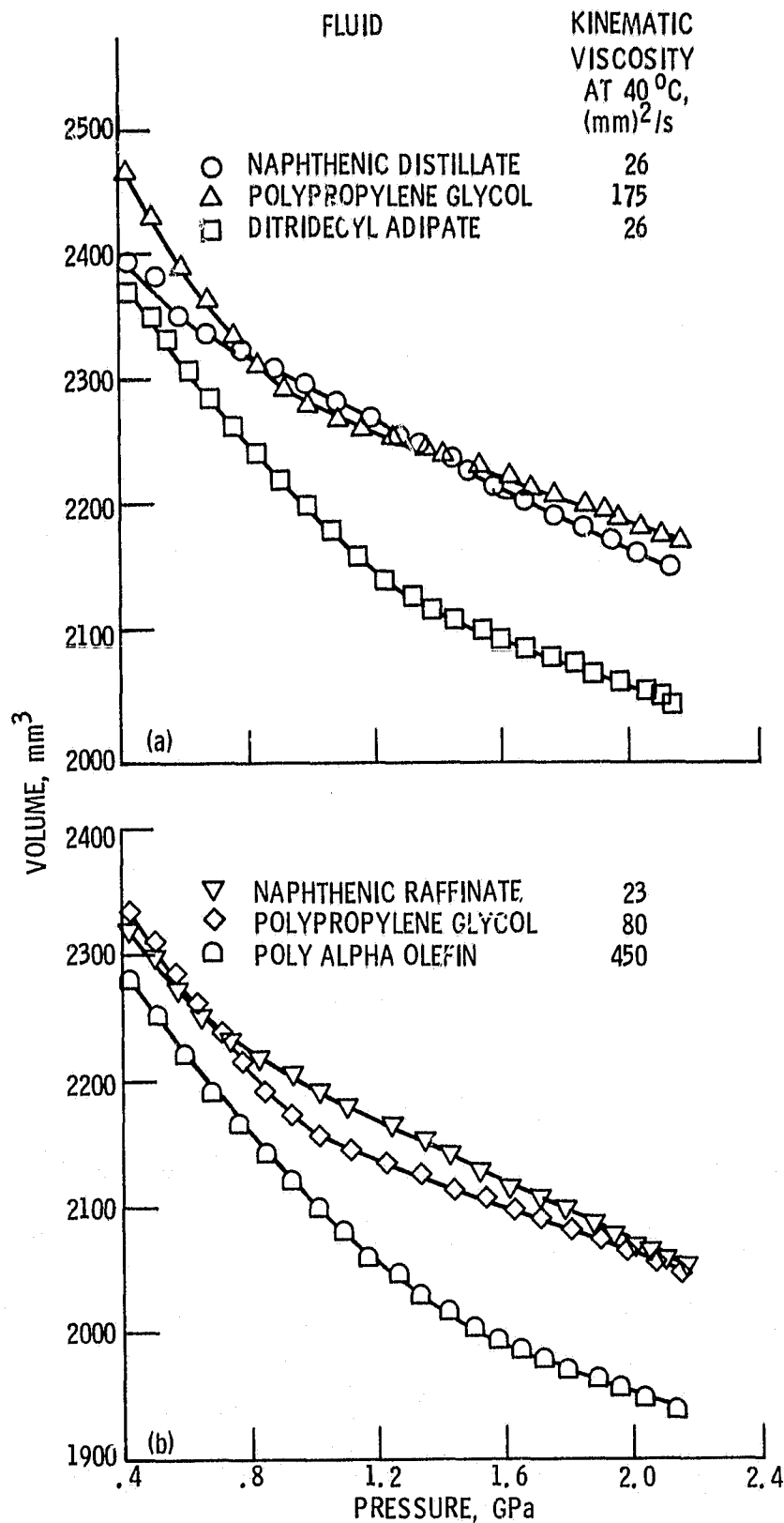

Fig. 2 Effect of pressure on volume for six base fluids. A constant temperature of 20°C was assumed.

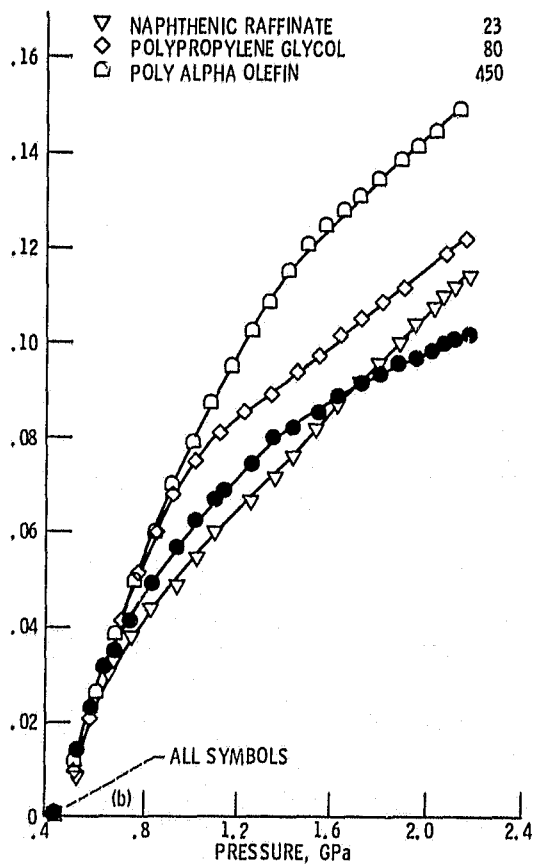
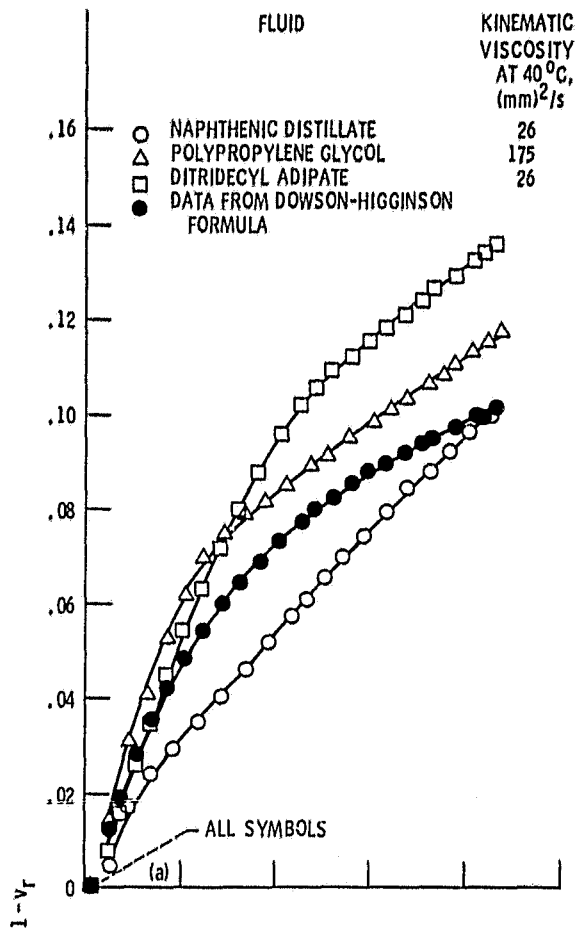

Fig. 3 Effect of pressure on relative volume for six base fluids. Data from Dowson and Higginson formula are also given. A constant temperature of 20 °C was assumed.

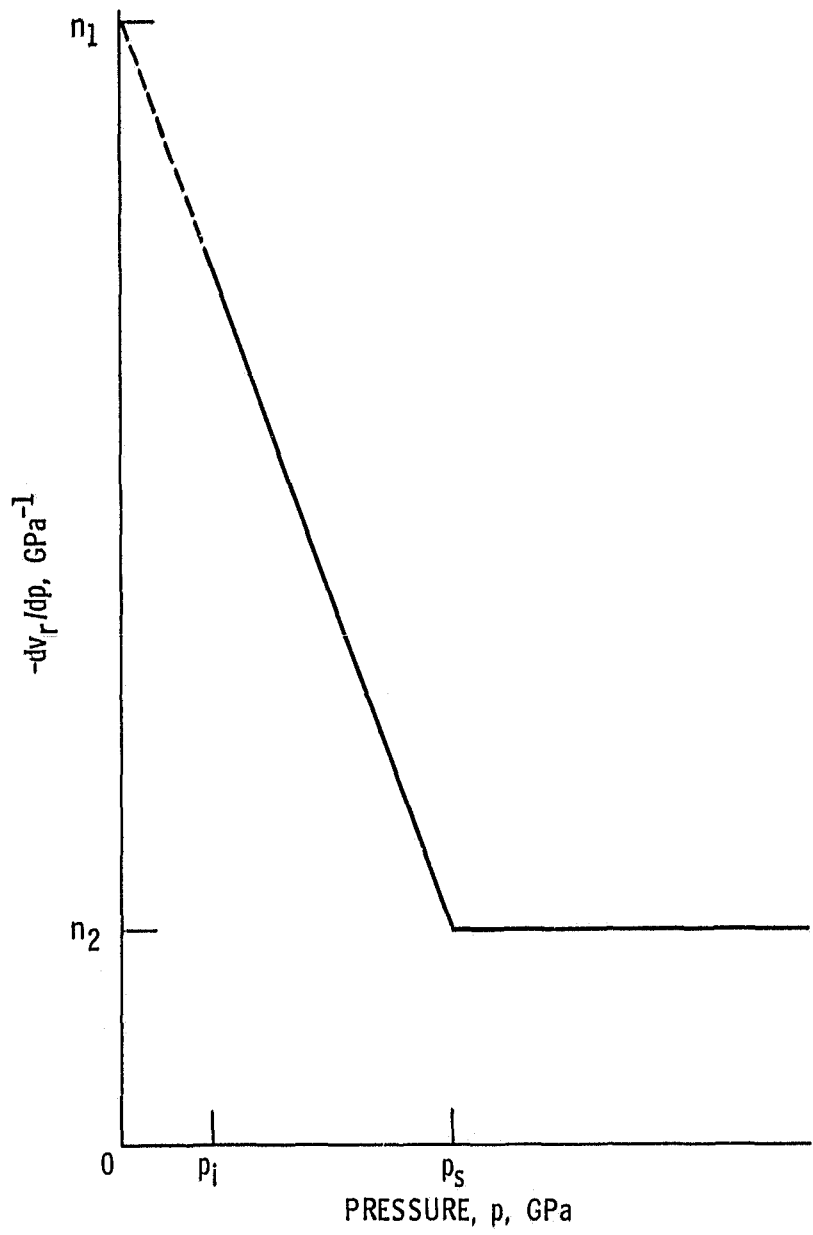

Fig. 4 Typical p versus $-dv_r/dp$ results for a fixed temperature.

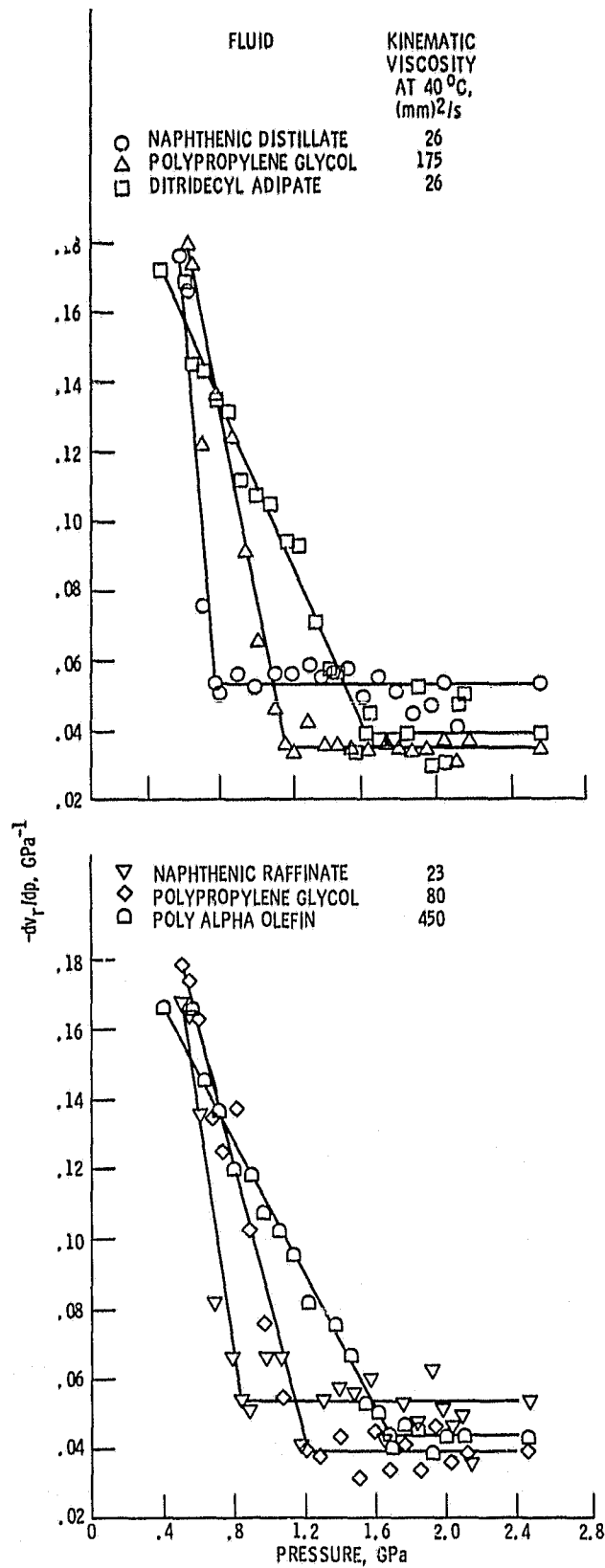

Fig. 5 Effect of pressure on change in relative volume with change in pressure for six base fluids. A constant temperature of 20°C was assumed.

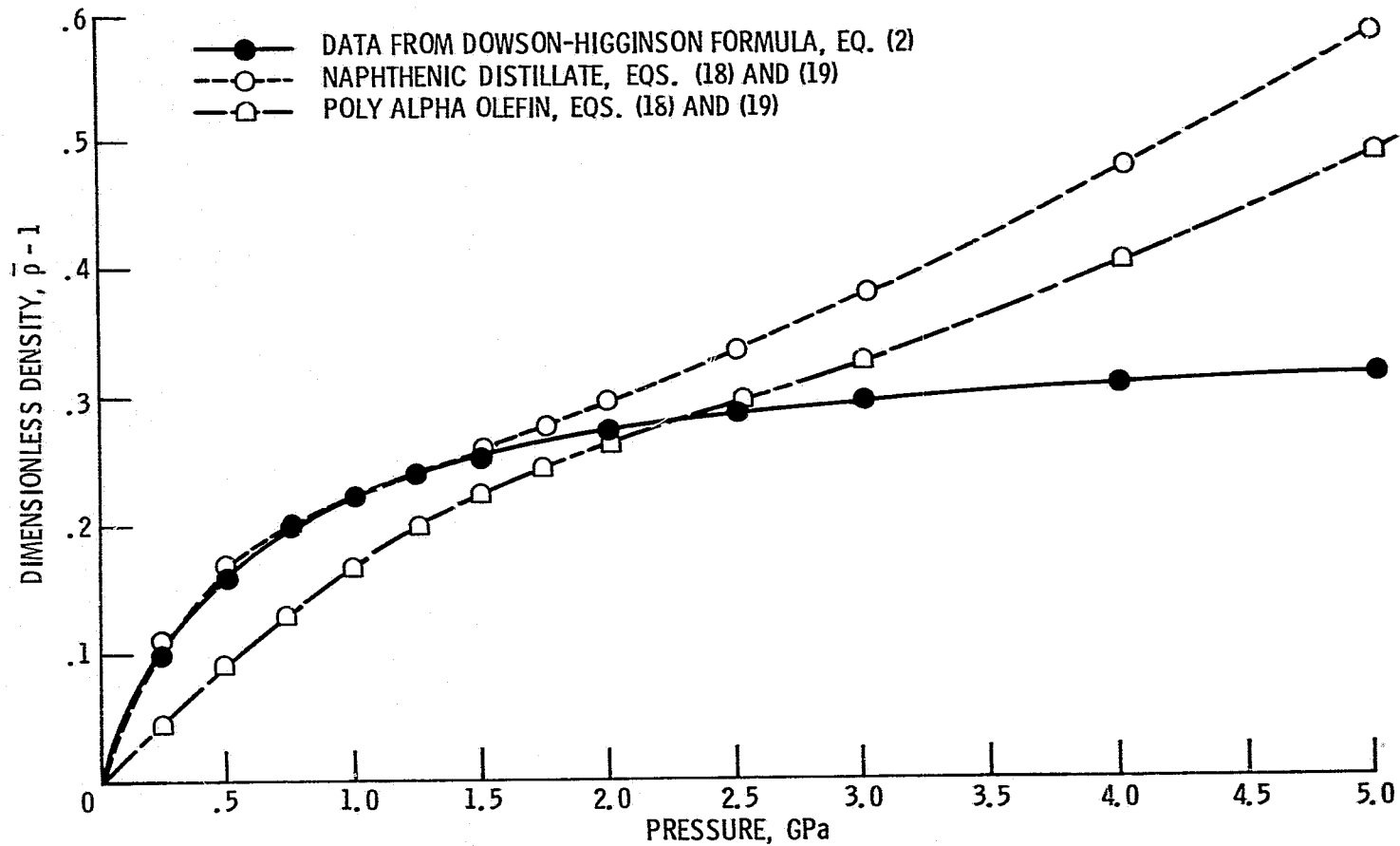

Fig. 6 Effect of pressure on density.

| | | | | | |
|---|--|---|--|--|------------|
| 1. Report No. NASA TM-87114 | | 2. Government Accession No. | | 3. Recipient's Catalog No. | |
| 4. Title and Subtitle Measurement of the Density of Base Fluids at Pressures to 2.20 GPa | | | | 5. Report Date | |
| | | | | 6. Performing Organization Code 505-33-62 | |
| 7. Author(s) Bernard J. Hamrock, Bo O. Jacobson, and Sten-Ivar Bergström | | | | 8. Performing Organization Report No. E-2650 | |
| | | | | 10. Work Unit No. | |
| 9. Performing Organization Name and Address National Aeronautics and Space Administration Lewis Research Center Cleveland, Ohio 44135 | | | | 11. Contract or Grant No. | |
| | | | | 13. Type of Report and Period Covered Technical Memorandum | |
| 12. Sponsoring Agency Name and Address National Aeronautics and Space Administration Washington, D.C. 20546 | | | | 14. Sponsoring Agency Code | |
| | | | | | |
| 15. Supplementary Notes Bernard J. Hamrock, NASA Lewis Research Center; Bo O. Jacobson and Sten-Ivar Bergström, University of Luleå, Luleå, Sweden. Prepared for the Annual Meeting of the American Society of Lubrication Engineers, Toronto, Canada, May 12-15, 1986. | | | | | |
| 16. Abstract The influence of pressure on the density of six base fluids was experimentally studied for a range of pressures from 0.422 to 2.20 GPa. An important parameter used to describe the results is the change in relative volume with change in pressure dv_r/dp . For pressures less than the solidification pressure ($p < p_s$) a small change in pressure resulted in a large change in dv_r/dp . For pressures greater than the solidification pressure ($p > p_s$) there was no change in dv_r/dp with changing pressure. The solidification pressures of the base fluids varied considerably, as did the slopes that the experimental data assumed for $p < p_s$. A new formula was developed that describes the effect of pressure on density in terms of four constants. These constants vary for the different base fluids tested. | | | | | |
| 17. Key Words (Suggested by Author(s)) Lubricants; Base fluids; Elastohydrodynamic lubrication | | | | 18. Distribution Statement Unclassified - unlimited STAR Category 37 | |
| 19. Security Classif. (of this report) Unclassified | | 20. Security Classif. (of this page) Unclassified | | 21. No. of pages | 22. Price* |