

NASA Technical Memorandum 86393

NASA-TM-86393 19860001113

THREE-DIMENSIONAL VIBRATION ANALYSIS OF A UNIFORM BEAM WITH OFFSET INERTIAL MASSES AT THE ENDS

Daniel K. Robertson

September 1985

LIBRARY COPY

OCT 10 1995

LANGLEY RESEARCH CENTER
LIBRARY, NASA
HAMPTON, VIRGINIA

NASA

National Aeronautics and
Space Administration

Langley Research Center
Hampton, Virginia 23665



NF00586

SUMMARY

Analysis of a flexible beam with displaced end-located inertial masses is presented. The resulting three-dimensional mode shape is shown to consist of two one-plane bending modes and one torsional mode. These three components of the mode shapes are shown to be linear combinations of trigonometric and hyperbolic sine and cosine functions. Boundary conditions are derived to obtain nonlinear algebraic equations through kinematic coupling of the general solutions of the three governing partial differential equations. A method of solution which takes these boundary conditions into account is also presented. A computer program has been written to obtain unique solutions to the resulting nonlinear algebraic equations. This program, which calculates natural frequencies and three-dimensional mode shapes for any number of modes, is presented and discussed.

INTRODUCTION

With the advent of the Space Shuttle, a new class of spacecraft has been emerging in recent years. This class of spacecraft, which includes large antennas, platforms, space stations, etc., will require large lightweight space structures. These systems will be highly flexible, and will have a large number of significant vibrational modes which (unlike conventional rigid spacecraft) can no longer be ignored while designing control systems. Because of small inherent damping and a large number of elastic modes, these large flexible systems will need complex control laws in order to accomplish the required degree of precision in their pointing and maneuvering. These control laws, however, cannot be designed unless accurate vibrational characteristics of the system can be obtained.

Many flexible space structures, as well as other terrestrial systems, can be represented by a single one-span beam with masses at both ends. Two shuttle based experiments which can be represented by this system are the Solar Array experiment, which flew in September 1984, and the Spacecraft Control Laboratory Experiment (SCOLE) (see ref. 1), which is a laboratory experiment in the design stage. For those structures whose end-mass centers of mass coincide with the principal axis of the beam, and have no product of inertia, simple one-plane vibrational analysis for each of the two planes (i.e., x-z and y-z planes) and one independent torsional vibration analysis are sufficient. (See ref. 2 for analysis of these types of systems.) However, if the centers of mass of the end masses do not lie on the beam axis, or if the products of inertia are not zero, then the three modes mentioned are coupled into one complex three-dimensional mode.

This paper presents one method of approaching the problem of three-dimensional vibration analysis of a uniform beam with offset inertial masses at each end. The method assumes that the system is adequately described by three governing partial differential equations (i.e., two one-plane bending and one torsional bending partial differential equations). With proper boundary conditions, taking into account the center of mass displacements, and products of inertia, the natural frequency and mode shape can be obtained for any number of modes. This paper presents such a set of boundary conditions as well as a computer program that makes the solution readily obtainable for any given set of parameters.

SYMBOLS

A	cross sectional area of beam
A_1, B_1, C_1, D_1	coefficients of x-z plane mode shape equation
A_2, B_2, C_2, D_2	coefficients of y-z plane mode shape equation
A_3, B_3	coefficients of torsional mode shape equation
c.m.	center of mass
EI	bending stiffness for beam when $(EI)_x = (EI)_y$
$(EI)_x$	x-z plane bending stiffness
$(EI)_y$	y-z plane bending stiffness
G	modulus of rigidity
I_p	polar moment of inertia
I_{xx}, I_{yy}, I_{zz}	x-, y-, and z-axis moments of inertia, respectively
$I_{xx0}, I_{yy0}, I_{zz0}$	x-, y-, and z-axis moments of inertia, respectively, at z = 0 on beam
$I_{xxL}, I_{yyL}, I_{zzL}$	x-, y-, and z-axis moments of inertia, respectively, at z = L on beam
I_{xy}	xy product of inertia
I_{xy0}	xy product of inertia at z = 0 on beam
I_{xyL}	xy product of inertia at z = L on beam
L	length of beam
M_x, M_y, M_z	moments about x-, y-, and z-axes, respectively
M_{x0}, M_{y0}, M_{z0}	moments about x-, y-, and z-axes, respectively, at z = 0 on beam
M_{xL}, M_{yL}, M_{zL}	moments about x-, y-, and z-axes, respectively, at z = L on beam
m_0	mass at z = 0 on beam
m_L	mass at z = L on beam
p(t)	common time solution of partial D.E's
$p_x(t), p_y(t), p_z(t)$	separate time solutions of xz-plane, yz-plane, and z-axis torsional P.D.E's, respectively

$r_x(z), r_x(\epsilon)$ xz-plane mode shape
 $r_y(z), r_y(\epsilon)$ yz-plane mode shape
 t time
 $u(z, t)$ beam displacement in xz-plane
 $v(z, t)$ beam displacement in yz-plane
 v_x, v_y shear forces in x- and y-directions, respectively
 V_{x0}, V_{y0} shear forces in x- and y-directions, respectively,
at $z = 0$ on beam
 V_{xL}, V_{yL} shear forces in x- and y-directions, respectively,
at $z = L$ on beam
 X, Y, Z position variables
 $Z(\omega)$ eigenvalue matrix
 α phase angle (rad)
 β_x, β_1 mode shape variable for xz-plane
 β_y, β_2 mode shape variable for yz-plane
 β_z, β_3 mode shape variable for z-axis torsion
 $\Delta x_0, \Delta y_0$ c.m. displacements in x- and y-directions, respectively,
at $z = 0$ on beam
 $\Delta x_L, \Delta y_L$ c.m. displacements in x- and y-directions, respectively,
at $z = L$ on beam
 ϵ dimensionless position variable ($\epsilon = z/L$)
 $\theta(z), \theta(\epsilon)$ z-axis torsional mode shape
 $\theta_x, \theta_x(z, t)$ angular displacement about x-axis
 $\theta_y, \theta_y(z, t)$ angular displacement about y-axis
 ρ density of beam
 $\phi(z, t)$ angular displacement about z-axis
 ω natural frequency common to all three governing partial D.E's
 $\omega_x, \omega_y, \omega_z$ natural frequency of vibration of xz-plane, yz-plane, and z-axis
torsional bending modes, respectively

THE GOVERNING DIFFERENTIAL EQUATIONS

The governing partial differential equations for the beam shown in figure 1 are comprised of two one-plane bending equations and one axial torsion equation. These differential equations all assume small displacements and slopes, uniform distribution of stiffness EI and density ρ , and the torsional equation is derived specifically for a circular shaft. These three equations are the following (refs. 2 and 3):

$$-\frac{\partial^2 u(z,t)}{\partial t^2} = \frac{(EI)_x}{\rho A} \frac{\partial^4 u(z,t)}{\partial z^4} \quad (1)$$

for x - z plane bending, and

$$-\frac{\partial^2 v(z,t)}{\partial t^2} = \frac{(EI)_y}{\rho A} \frac{\partial^4 v(z,t)}{\partial z^4} \quad (2)$$

for y - z plane bending, and

$$\frac{\partial^2 \phi(z,t)}{\partial t^2} = \frac{G}{\rho} \frac{\partial^2 \phi(z,t)}{\partial z^2} \quad (3)$$

for z -axis torsional bending. In equations (1), (2), (3), z denotes the independent space variable along the z -axis, t is the time, u , v , and ϕ respectively denote the x - and y -axis bending and torsional displacement. $(EI)_x$, $(EI)_y$, G , ρ and A respectively denote the x - z and y - z plane bending stiffness, the modulus of rigidity, the density, and the cross-sectional area.

These three equations are solved by separation of variables with the following substitutions (refs. 2 and 3):

$$u(z,t) = r_x(z)p_x(t) \quad (4)$$

and

$$v(z,t) = r_y(z)p_y(t) \quad (5)$$

and

$$\phi(z,t) = \theta(z)p_z(t) \quad (6)$$

Where r_x , r_y and θ denote the bending and torsional mode shapes, and p_x , p_y , p_z denote the corresponding functions of time. Substituting equations (4), (5), and (6) into equations (1), (2), and (3) and rearranging terms, equations (1), (2), and (3) are transformed, respectively, into:

$$-\frac{d^2 p_x(t)}{dt^2} \frac{1}{p_x(t)} = \frac{(EI)_x}{\rho A} \frac{1}{r_x(z)} \frac{d^4 r_x(z)}{dz^4} \quad (7)$$

$$-\frac{d^2 p_y(t)}{dt^2} \frac{1}{p_y(t)} = \frac{(EI)_y}{\rho A} \frac{1}{r_y(z)} \frac{d^4 r_y(z)}{dz^4} \quad (8)$$

and

$$-\frac{1}{p_z(t)} \frac{d^2 p_z(t)}{dt^2} = \frac{G}{\rho} \frac{1}{\theta(z)} \frac{d^2 \theta(z)}{dz^2} \quad (9)$$

Equations (7), (8), and (9) can be true if, and only if, both sides of each equation are equal to a constant. If the respective constants are chosen to be $-\omega_x^2$, $-\omega_y^2$, and $-\omega_z^2$, the following six ordinary homogeneous differential equations are obtained.

For the x-z plane bending:

$$\frac{d^2 p_x(t)}{dt^2} + \omega_x^2 p_x(t) = 0 \quad (10)$$

and

$$\frac{d^4 r_x(z)}{dz^4} - \beta_x^4 r_x(z) = 0 \quad (11)$$

where

$$\beta_x^4 = \frac{\rho A}{(EI)_x} \omega_x^2 \quad (12)$$

For the y-z plane bending:

$$\frac{d^2 p_x(t)}{dt^2} + \omega_y^2 p_y(t) = 0 \quad (13)$$

and

$$\frac{d^4 r_y(z)}{dz^4} - \beta_y^4 r_y(z) = 0 \quad (14)$$

where

$$\beta_y^4 = \frac{\rho A}{(EI)_y} \omega_y^2 \quad (15)$$

For the z-axis torsional bending:

$$\frac{d^2 p_z(t)}{dt^2} + \omega_z^2 p_z(t) = 0 \quad (16)$$

and

$$\frac{d^2 \theta(z)}{dz^2} - \omega_z^2 \frac{\rho}{G} \theta(z) = 0 \quad (17)$$

The system which is being modeled will be considered to be vibrating with the same frequency ω in all three independent modes. This simplification gives all three modes the same time dependent governing equation:

$$\frac{d^2 p(t)}{dt^2} + \omega^2 p(t) = 0 \quad (18)$$

[i.e., $p_x(t) = p_y(t) = p_z(t) = p(t)$].

The solution to equation (18) is (refs. 2 and 3):

$$p(t) = \cos (\omega t + \alpha) \quad (19)$$

where α is a phase angle.

The solutions to the position dependent equations (11), (14), and (17) with $\omega_x = \omega_y = \omega_z = \omega$ are found to be (refs. 2 and 3):

$$r_x(z) = A_1 \sin \beta_x z + B_1 \cos \beta_x z + C_1 \sinh \beta_x z + D_1 \cosh \beta_x z \quad (20)$$

$$r_y(z) = A_2 \sin \beta_y z + B_2 \cos \beta_y z + C_2 \sinh \beta_y z + D_2 \cosh \beta_y z \quad (21)$$

$$\theta(z) = A_3 \sin \beta_z z + B_3 \cos \beta_z z \quad (22)$$

where

$$\beta_x = \left(\frac{\rho A}{(EI)_x} \omega^2 \right)^{1/4} \quad (23)$$

$$\beta_y = \left(\frac{\rho A}{(EI)_y} \omega^2 \right)^{1/4} \quad (24)$$

$$\beta_z = \omega \sqrt{\frac{\rho}{G}} \quad (25)$$

Equations (20), (21), and (22) are more convenient to use when the position variable is transformed into a nondimensional form. For this reason the variable $\epsilon = z/L$, where L is the length of the beam, is used. After substitution, equations (20), (21), and (22) become:

$$r_x(\epsilon) = A_1 \sin \beta_1 \epsilon + B_1 \cos \beta_1 \epsilon + C_1 \sinh \beta_1 \epsilon + D_1 \cosh \beta_1 \epsilon \quad (26)$$

$$r_y(\epsilon) = A_2 \sin \beta_2 \epsilon + B_2 \cos \beta_2 \epsilon + C_2 \sinh \beta_2 \epsilon + D_2 \cosh \beta_2 \epsilon \quad (27)$$

$$\theta(\epsilon) = A_3 \sin \beta_3 \epsilon + B_3 \cos \beta_3 \epsilon \quad (28)$$

where

$$\beta_1^4 = \frac{\rho A}{(EI)_x} \omega^2 L^4 \quad (29)$$

$$\beta_2^4 = \frac{\rho A}{(EI)_y} \omega^2 L^4 \quad (30)$$

$$\beta_3^2 = \frac{\rho}{G} \omega^2 L^2 \quad (31)$$

Boundary Conditions for Three-Dimensional Vibrations of a Beam With Displaced Inertial End Masses

The configuration being considered is a beam with inertial masses at both ends with x- and y-axis offsets. (See fig. 1.) The offset center of mass, along with the product of inertia, cause kinematic coupling between the x-z and y-z plane bending modes and the z-axis torsional mode. Figures 2 and 3 show the moment and shear force reactions being considered in the configuration.

The following relationships between shear, moment, and beam displacement are used in the boundary conditions (ref. 4):

$$V_x = -(EI)_x \frac{\partial^3 u(z,t)}{\partial z^3} \quad (32)$$

$$V_y = -(EI)_y \frac{\partial^3 v(z,t)}{\partial z^3} \quad (33)$$

$$M_x = -(EI)_y \frac{\partial^2 v(z,t)}{\partial z^2} \quad (34)$$

$$M_y = (EI)_x \frac{\partial^2 u(z,t)}{\partial z^2} \quad (35)$$

$$M_z = GI_p \frac{\partial \phi(z,t)}{\partial z} \quad (36)$$

When $\epsilon = z/L$ is substituted into equations (32) through (36), the following relationships are obtained:

$$V_x = - \frac{(EI)_x}{L^3} \frac{\partial^3 u(\epsilon, t)}{\partial \epsilon^3} \quad (37)$$

$$V_y = - \frac{(EI)_y}{L^3} \frac{\partial^3 v(\epsilon, t)}{\partial \epsilon^3} \quad (38)$$

$$M_x = - \frac{(EI)_y}{L^2} \frac{\partial^2 v(\epsilon, t)}{\partial \epsilon^2} \quad (39)$$

$$M_y = \frac{(EI)_x}{L^2} \frac{\partial^2 u(\epsilon, t)}{\partial \epsilon^2} \quad (40)$$

$$M_z = \frac{GI_P}{L} \frac{\partial \phi(\epsilon, t)}{\partial \epsilon} \quad (41)$$

Shear Forces at $z = 0$

Referring to figure 2, the first boundary conditions involve the shears V_{x0} and V_{y0} which are described by the following relationships:

$$V_{x0} = -(EI)_x \frac{\partial^3 u(z, t)}{\partial z^3} \quad \text{at } z = 0 \quad (42)$$

$$V_{y0} = -(EI)_y \frac{\partial^3 v(z, t)}{\partial z^3} \quad \text{at } z = 0 \quad (43)$$

Setting equations (42) and (43) equal to the mass m_0 times the corresponding components of acceleration yields the following relationships.

$$m_0 \left[\frac{\partial^2 u(z, t)}{\partial t^2} - \Delta y_0 \frac{\partial^2 \phi(z, t)}{\partial t^2} \right] = -(EI)_x \frac{\partial^3 u(z, t)}{\partial z^3} \quad (44)$$

$$m_0 \left[\frac{\partial^2 v(z, t)}{\partial t^2} + \Delta x_0 \frac{\partial^2 \phi(z, t)}{\partial t^2} \right] = -(EI)_y \frac{\partial^3 v(z, t)}{\partial z^3} \quad (45)$$

The following substitutions will be used to transform equations (44) and (45) into usable form:

$$u(\epsilon, t) = r_x(\epsilon)p(t) \quad (46)$$

$$v(\epsilon, t) = r_y(\epsilon)p(t) \quad (47)$$

$$\phi(\epsilon, t) = \theta(\epsilon)p(t) \quad (48)$$

where

$$\epsilon = z/L \quad (49)$$

Using these four relationships, equations (44) and (45) become:

$$\left. \begin{aligned} m_0 \frac{d^2 p(t)}{dt^2} [r_x(\epsilon) - \Delta y_0 \theta(\epsilon)] &= - \frac{(EI)_x}{L^3} \frac{d^3 r_x(\epsilon)}{d\epsilon^3} p(t) \\ m_0 \frac{d^2 p(t)}{dt^2} [r_y(\epsilon) + \Delta_0 \theta(\epsilon)] &= - \frac{(EI)_y}{L^3} \frac{d^3 r_y(\epsilon)}{d\epsilon^3} p(t) \end{aligned} \right\} \text{at } \epsilon = 0. \quad (50)$$

$$\left. \begin{aligned} m_0 \frac{d^2 p(t)}{dt^2} [r_x(\epsilon) - \Delta y_0 \theta(\epsilon)] &= - \frac{(EI)_x}{L^3} \frac{d^3 r_x(\epsilon)}{d\epsilon^3} p(t) \\ m_0 \frac{d^2 p(t)}{dt^2} [r_y(\epsilon) + \Delta_0 \theta(\epsilon)] &= - \frac{(EI)_y}{L^3} \frac{d^3 r_y(\epsilon)}{d\epsilon^3} p(t) \end{aligned} \right\} \text{at } \epsilon = 0. \quad (51)$$

Equation (18) can be rewritten as:

$$\frac{d^2 p(t)}{dt^2} = -\omega^2 p(t) \quad (52)$$

Using equations (52), equations (50) and (51) can be rewritten as:

$$-\omega^2 m_0 [r_x(\epsilon) - \Delta y_0 \theta(\epsilon)] = - \frac{(EI)_x}{L^3} \frac{d^3 r_x(\epsilon)}{d\epsilon^3} \quad (53)$$

$$-\omega^2 m_0 [r_y(\epsilon) + \Delta x_0 \theta(\epsilon)] = - \frac{(EI)_y}{L^3} \frac{d^3 r_y(\epsilon)}{d\epsilon^3} \quad (54)$$

or after rearranging terms:

$$\frac{d^3 r_x(\epsilon)}{d\epsilon^3} = \frac{m_0}{\rho AL} \beta_1^4 [r_x(\epsilon) + \Delta y_0 \theta(\epsilon)] \quad \text{at } \epsilon = 0 \quad (55)$$

where β_1 is given by equation (29).

$$\frac{d^3 r_y(\epsilon)}{d\epsilon^3} = \frac{m_0}{\rho AL} \beta_2^4 [r_y(\epsilon) + \Delta x_0 \theta(\epsilon)] \quad \text{at } \epsilon = 0 \quad (56)$$

where β_2 is given by equation (30).

Shear Forces at $z = L$

Again referring to figure 2, the next set of boundary conditions involves the shears V_{xL} and V_{yL} at $z = L$ on the beam. These are derived with relationships similar to those used for the first two (V_{x0} and V_{y0}), the only difference being in the sign convention used in the derivation of the governing differential equations (ref. 3). For the end $z = L$ the following relationships apply:

$$V_{xL} = \frac{EI_2}{L^3} \frac{\partial^3 u(\epsilon, t)}{\partial \epsilon^3} \quad \text{at } z = L \quad (57)$$

and

$$V_{yL} = \frac{EI_1}{L^3} \frac{\partial^3 v(\epsilon, t)}{\partial \epsilon^3} \quad \text{at } z = L \quad (58)$$

Setting equations (57) and (58) equal to the mass m_L times the corresponding component of acceleration, the following relationships are obtained:

$$V_{xL} = m_L \left[\frac{\partial^2 u(\epsilon, t)}{dt^2} - \Delta y_L \frac{\partial^2 \phi(\epsilon, t)}{dt^2} \right] = \frac{(EI)_x}{L^3} \frac{\partial^3 u(\epsilon, t)}{\partial \epsilon^3} \quad (59)$$

$$V_{yL} = m_L \left[\frac{\partial^2 v(\epsilon, t)}{dt^2} + \Delta x_L \frac{\partial^2 \phi(\epsilon, t)}{dt^2} \right] = \frac{(EI)_y}{L^3} \frac{\partial^3 v(\epsilon, t)}{\partial \epsilon^3} \quad (60)$$

} at $\epsilon = 1$

Using relationships (46) through (49) and (52) in equations (59) and (60) and rearranging, the following boundary condition equations are obtained:

$$\frac{d^3 r_x(\epsilon)}{d\epsilon^3} = \frac{m_L}{\rho AL} \beta_1^4 [-r_x(\epsilon) + \Delta y_L \theta(\epsilon)] \quad \text{at } \epsilon = 1 \quad (61)$$

where β_1 is given by equation (29).

$$\frac{d^3 r_y(\epsilon)}{d\epsilon^3} = \frac{m_L}{\rho AL} \beta_2^4 [-r_y(\epsilon) - \Delta x_L \theta(\epsilon)] \quad \text{at } \epsilon = 1 \quad (62)$$

where β_2 is given by equation (30).

Bending Moments at $z = 0$

Referring to figure 3 the next two boundary conditions involve the moments M_{x0} and M_{y0} at $z = 0$ on the beam. Equations (34) and (35) are equated with the following relationships (ref. 5) which ignore all nonlinear coupling and require that all products of inertia except I_{xy} are zero:

$$M_x = I_{xx} \ddot{\theta}_x + I_{xy} \ddot{\theta}_y \quad (63)$$

$$M_y = I_{yy} \ddot{\theta}_y + I_{xy} \ddot{\theta}_x \quad (64)$$

Combining equations (63) and (64) with equations (34) and (35), respectively, and applying them to the end at $z = 0$ one obtains:

$$M_{x0} = I_{xx0} \ddot{\theta}_x + I_{xy0} \ddot{\theta}_y = -(EI)_y \frac{\partial^2 v(z,t)}{\partial z^2} \quad (65)$$

$$M_{y0} = I_{yy0} \ddot{\theta}_y + I_{xy0} \ddot{\theta}_x = (EI)_x \frac{\partial^2 u(z,t)}{\partial z^2} \quad (66)$$

at $z = 0$

The angular displacements θ_x and θ_y can be approximated by the slopes of the y- and x-displacements, respectively:

$$\theta_x(z,t) = -\frac{\partial v(z,t)}{\partial z} \quad (67)$$

$$\theta_y(z,t) = \frac{\partial u(z,t)}{\partial z} \quad (68)$$

(The sign-convention used for rotations is the one corresponding to the standard right-handed coordinate system.) Using equations (67) and (68), equations (65) and (66) become:

$$\left. \begin{aligned} -I_{xx0} \frac{\partial^3 v(z,t)}{\partial z \partial t^2} + I_{xy0} \frac{\partial^3 u(z,t)}{\partial z \partial t^2} &= -(EI)_y \frac{\partial^2 v(z,t)}{\partial z^2} \\ I_{yy0} \frac{\partial^3 u(z,t)}{\partial z \partial t^2} - I_{xy0} \frac{\partial^3 v(z,t)}{\partial z \partial t^2} &= (EI)_x \frac{\partial^2 u(z,t)}{\partial z^2} \end{aligned} \right\} \text{at } z = 0 \quad (69)$$

$$\left. \begin{aligned} -I_{xx0} \frac{\partial^3 v(z,t)}{\partial z \partial t^2} + I_{xy0} \frac{\partial^3 u(z,t)}{\partial z \partial t^2} &= -(EI)_y \frac{\partial^2 v(z,t)}{\partial z^2} \\ I_{yy0} \frac{\partial^3 u(z,t)}{\partial z \partial t^2} - I_{xy0} \frac{\partial^3 v(z,t)}{\partial z \partial t^2} &= (EI)_x \frac{\partial^2 u(z,t)}{\partial z^2} \end{aligned} \right\} \text{at } z = 0 \quad (70)$$

Using relationships (46), (47), and (49), equations (69) and (70) become:

$$\frac{d^2 p(t)}{dt^2} \left[-\frac{I_{xx0}}{L} \frac{dr_y(\epsilon)}{d\epsilon} + \frac{I_{xy0}}{L} \frac{dr_x(\epsilon)}{d\epsilon} \right] = -\frac{(EI)_y}{L^2} \frac{d^2 r_y(\epsilon)}{d\epsilon^2} p(t) \quad (71)$$

$$\frac{d^2 p(t)}{dt^2} \left[\frac{I_{yy0}}{L} \frac{dr_x(\epsilon)}{d\epsilon} - \frac{I_{xy0}}{L} \frac{dr_y(\epsilon)}{d\epsilon} \right] = \frac{(EI)_x}{L^2} \frac{d^2 r_x(\epsilon)}{d\epsilon^2} p(t) \quad (72)$$

Using equation (52) in equations (71) and (72), the following two boundary condition equations are obtained:

$$\frac{d^2 r_y(\epsilon)}{d\epsilon^2} = \frac{\beta_2^4}{\rho A L^3} \left[-I_{xx0} \frac{dr_y(\epsilon)}{d\epsilon} + I_{xy0} \frac{dr_x(\epsilon)}{d\epsilon} \right] \text{at } \epsilon = 0 \quad (73)$$

where β_2 is given by equation (30).

$$\frac{d^2 r_x(\epsilon)}{d\epsilon^2} = \frac{\beta_1^4}{\rho AL^3} \left[-I_{yy0} \frac{dr_x(\epsilon)}{d\epsilon} + I_{xy0} \frac{dr_y(\epsilon)}{d\epsilon} \right] \text{ at } \epsilon = 0 \quad (74)$$

where β_1 is given by equation (29).

Bending Moments at $z = L$

The fourth pair of boundary conditions involves the moments at the $z = L$ end of the beam (see fig. 3). This set uses equations very similar to those used in set III. The only difference is in the sign convention necessary to satisfy the governing partial differential equations (ref. 3). The x - and y -moments at $z = L$ are given by:

$$M_{xL} = (EI)_y \frac{\partial^2 v(z,t)}{\partial z^2} \text{ at } z = L \quad (75)$$

$$M_{yL} = -(EI)_x \frac{\partial^2 u(z,t)}{\partial z^2} \text{ at } z = L \quad (76)$$

Setting equations (75) and (76) equal to equations (63) and (64), respectively, and using relationships (67) and (68), the following equations are obtained:

$$-I_{xxL} \frac{\partial^3 v(z,t)}{\partial z \partial t^2} + I_{xyL} \frac{\partial^3 u(z,t)}{\partial z \partial t^2} = -(EI)_y \frac{\partial^2 v(z,t)}{\partial z^2} \text{ at } z = L \quad (77)$$

$$I_{yyL} \frac{\partial^3 u(z,t)}{\partial z \partial t^2} - I_{xyL} \frac{\partial^3 v(z,t)}{\partial z \partial t^2} = -(EI)_x \frac{\partial^2 u(z,t)}{\partial z^2} \text{ at } z = L \quad (78)$$

Using the relationships (46), (47), and (49), equations (77) and (78) become:

$$\frac{d^2 p(t)}{dt^2} \left[-\frac{I_{xxL}}{L} \frac{dr_y(\epsilon)}{d\epsilon} + \frac{I_{xyL}}{L} \frac{dr_x(\epsilon)}{d\epsilon} \right] = \frac{(EI)_y}{L^2} \frac{d^2 r_y(\epsilon)}{d\epsilon^2} p(t) \text{ at } \epsilon = 1 \quad (79)$$

$$\frac{d^2 p(t)}{dt^2} \left[-\frac{I_{yyL}}{L} \frac{dr_x(\epsilon)}{d\epsilon} + \frac{I_{xyL}}{L} \frac{dr_y(\epsilon)}{d\epsilon} \right] = \frac{(EI)_x}{L^2} \frac{d^2 r_x(\epsilon)}{d\epsilon^2} p(t) \quad \text{at } \epsilon = 1 \quad (80)$$

Using equation (52) in equations (79) and (80) and reducing gives rise to the following boundary condition equations:

$$\frac{d^2 r_y(\epsilon)}{d\epsilon^2} = \frac{\beta_2^4}{\rho AL^3} \left[I_{xxL} \frac{dr_y(\epsilon)}{d\epsilon} - I_{xyL} \frac{dr_x(\epsilon)}{d\epsilon} \right] \quad \text{at } \epsilon = 1 \quad (81)$$

where β_2 is given by equation (30).

$$\frac{d^2 r_x(\epsilon)}{d\epsilon^2} = \frac{\beta_1^4}{\rho AL^3} \left[I_{yyL} \frac{dr_x(\epsilon)}{d\epsilon} - I_{xyL} \frac{dr_y(\epsilon)}{d\epsilon} \right] \quad \text{at } \epsilon = 1 \quad (82)$$

where β_1 is given by equation (29).

Torsional Moment at $z = 0$

The ninth boundary condition involves the z -moment at $z = 0$ (see fig. 3). This moment is caused by the mass m_0 and moment of inertia I_{zz0} according to the following relationship (refs. 3 and 5):

$$M_{z0} = I_{zz0} \frac{\partial^2 \phi(z,t)}{\partial t^2} + m_0 \left[\frac{\partial^2 v(z,t)}{\partial t^2} \Delta x_0 - \frac{\partial^2 u(z,t)}{\partial t^2} \Delta y_0 \right] \quad (83)$$

This moment is countered by the internal beam moment given by equation (36). Setting equation (83) equal to equation (36) gives the following:

$$I_{zz0} \frac{\partial^2 \phi(z,t)}{\partial t^2} + m_0 \left[\frac{\partial^2 v(z,t)}{\partial t^2} \Delta x_0 - \frac{\partial^2 u(z,t)}{\partial t^2} \Delta y_0 \right] = GI_p \frac{\partial \phi(z,t)}{\partial z} \quad (84)$$

at $z = 0$

Using the substitutions given by equations (46) through (49), the following is obtained:

$$\frac{d^2 p(t)}{dt^2} \{ I_{zz0} \theta(\epsilon) + m_0 [r_y(\epsilon) \Delta x_0 - r_x(\epsilon) \Delta y_0] \} = \frac{GI_p}{L} \frac{\partial \theta(\epsilon)}{\partial \epsilon} p(t) \quad (85)$$

at $\epsilon = 0$

Using the substitution given by equation (52) and rearranging terms, the following boundary condition equation is formed:

$$\frac{d\theta(\epsilon)}{d\epsilon} = \frac{\beta_3^2}{\rho L I_p} [-I_{zz0} \theta(\epsilon) - m_0 \Delta x_0 r_y(\epsilon) + m_0 \Delta y_0 r_x(\epsilon)] \quad \text{at } \epsilon = 0 \quad (86)$$

where β_3 is given by equation (31).

Torsion Moment at $z = L$

The tenth and final boundary condition involves the moment at $z = L$ (see fig. 3). This moment follows the same relationship given in equation (83) but the countering moment changes sign as in the other cases at $z = L$. This countering moment is given by:

$$M_{zL} = -GI_p \frac{\partial \phi(z,t)}{\partial z} \quad \text{at } z = L \quad (87)$$

The following equation is obtained, which is similar to equation (84):

$$m_L \left[\frac{\partial^2 v(z,t)}{\partial t^2} \Delta x_L - \frac{\partial^2 u(z,t)}{\partial t^2} \Delta y_L \right] + I_{zzL} \frac{\partial^2 \phi(z,t)}{\partial t^2} = -GI_p \frac{\partial \phi(z,t)}{\partial z} \quad (88)$$

at $z = L$

Using the substitutions given by equations (46) through (49), equation (88) is changed to:

$$\frac{d^2 p(t)}{dt^2} \{ I_{zzL} \theta(\epsilon) + m_L [\Delta x_L r_y(\epsilon) - \Delta y_L r_x(\epsilon)] \} = -\frac{GI_p}{L} \frac{\partial \theta(\epsilon)}{\partial \epsilon} p(t) \quad (89)$$

Using equation (52) in equation (89) and rearranging terms gives the following:

$$\frac{d\theta(\epsilon)}{d\epsilon} = \frac{\beta_3^2}{\rho L I_p} [I_{zzL} \theta(\epsilon) + m_L \Delta x_L r_y(\epsilon) - m_L \Delta y_L r_x(\epsilon)] \quad \text{at } \epsilon = 1 \quad (90)$$

where β_3 is given by equation (31).

By substituting equations (26), (27), and (28) and appropriate values of ϵ (i.e., $\epsilon = 0$ at boundary 1 and $\epsilon = 1$ at boundary 2) into equations (55), (56), (61), (62), (73), (74), (81), (82), (86), and (90), the following ten linear equations are obtained, respectively:

$$-A_1 - \left(\frac{\beta_1 m_0}{\rho AL} \right) B_1 + C_1 - \left(\frac{\beta_1 m_0}{\rho AL} \right) D_1 + \left(\frac{\beta_1 m_0 \Delta y_0}{\rho AL} \right) B_3 = 0 \quad (91)$$

$$-A_2 - \left(\frac{\beta_2 m_0}{\rho AL} \right) B_2 + C_2 - \left(\frac{\beta_2 m_0}{\rho AL} \right) D_2 + \left(\frac{\beta_2 m_0 \Delta x_0}{\rho AL} \right) B_3 = 0 \quad (92)$$

$$\begin{aligned} & \left[\frac{\beta_1 m_L}{\rho AL} \sin(\beta_1) - \cos(\beta_1) \right] A_1 + \left[\frac{\beta_1 m_L}{\rho AL} \cos(\beta_1) + \sin(\beta_1) \right] B_1 \\ & + \left[\frac{\beta_1 m_L}{\rho AL} \sinh(\beta_1) - \cosh(\beta_1) \right] C_1 + \left[\frac{\beta_1 m_L}{\rho AL} \cosh(\beta_1) + \sinh(\beta_1) \right] D_1 \\ & + \left[\frac{\beta_1 m_L \Delta y_L}{\rho AL} \sin(\beta_3) \right] A_3 + \left[\frac{\beta_1 m_L \Delta y_L}{\rho AL} \cos(\beta_3) \right] B_3 = 0 \end{aligned} \quad (93)$$

$$\begin{aligned} & \left[\frac{\beta_2 m_L}{\rho AL} \sin(\beta_2) - \cos(\beta_2) \right] A_2 + \left[\frac{\beta_2 m_L}{\rho AL} \cos(\beta_2) + \sin(\beta_2) \right] B_2 \\ & + \left[\frac{\beta_2 m_L}{\rho AL} \sinh(\beta_2) - \cosh(\beta_2) \right] C_2 + \left[\frac{\beta_2 m_L}{\rho AL} \cosh(\beta_2) + \sinh(\beta_2) \right] D_2 \\ & + \left[\frac{\beta_2 m_L \Delta x_L}{\rho AL} \sin(\beta_3) \right] A_3 + \left[\frac{\beta_2 m_L \Delta x_L}{\rho AL} \cos(\beta_3) \right] B_3 = 0 \end{aligned} \quad (94)$$

$$-\left(\frac{\beta_2^2 \beta_1 I_{xy0}}{\rho AL^3}\right)(A_1 + C_1) + \left(\frac{\beta_2^3 I_{xx0}}{\rho AL^3}\right)A_2 - B_2 + \left(\frac{\beta_2^3 I_{xx0}}{\rho AL^2}\right)C_2 + D_2 = 0 \quad (95)$$

$$\left(\frac{\beta_1^3 I_{yy0}}{\rho AL^3}\right)A_1 - B_1 + \left(\frac{\beta_1^3 I_{yy0}}{\rho AL^3}\right)C_1 + D_1 - \left(\frac{\beta_1^2 \beta_2 I_{xx0}}{\rho AL^3}\right)(A_2 + C_2) = 0 \quad (96)$$

$$\begin{aligned} & \left(\frac{\beta_2^2 \beta_1 I_{xyL}}{\rho AL^3}\right) \{ [\cos(\beta_1)]A_1 - [\sin(\beta_1)]B_1 + [\cosh(\beta_1)]C_1 + [\sinh(\beta_1)]D_1 \} \\ & + \left[-\frac{\beta_2^3 I_{xxL}}{\rho AL^3} \cos(\beta_2) - \sin(\beta_2) \right] A_2 + \left[\frac{\beta_2^3 I_{xxL}}{\rho AL^3} \sin(\beta_2) - \cos(\beta_2) \right] B_2 \\ & + \left[-\frac{\beta_2^3 I_{xxL}}{\rho AL^3} \cosh(\beta_2) - \sinh(\beta_2) \right] C_2 + \left[-\frac{\beta_2^3 I_{xxL}}{\rho AL^3} \sinh(\beta_2) - \cosh(\beta_2) \right] D_2 = 0 \quad (97) \end{aligned}$$

$$\begin{aligned} & \left[-\frac{\beta_1^3 I_{yyL}}{\rho AL^3} \cos(\beta_1) - \sin(\beta_1) \right] A_1 + \left[\frac{\beta_1^3 I_{yyL}}{\rho AL^3} \sin(\beta_1) - \cos(\beta_1) \right] B_1 \\ & + \left[-\frac{\beta_1^3 I_{yyL}}{\rho AL^3} \cosh(\beta_1) + \sinh(\beta_1) \right] C_1 + \left[-\frac{\beta_1^3 I_{yyL}}{\rho AL^3} \sinh(\beta_1) + \cosh(\beta_1) \right] D_1 \\ & + \left(\frac{\beta_1^2 \beta_2 I_{xyL}}{\rho AL^3}\right) \{ [\cos(\beta_2)]A_2 - [\sin(\beta_2)]B_2 + [\cosh(\beta_2)]C_2 + [\sinh(\beta_2)]D_2 \} = 0 \quad (98) \end{aligned}$$

$$\begin{aligned} & \left(-\frac{\beta_3 m_0 \Delta y_0}{\rho LI_p}\right)(B_1 + D_1) + \left(\frac{\beta_3 m_0 \Delta x_0}{\rho LI_p}\right)(B_2 + D_2) \\ & + A_3 + \left(\frac{\beta_3 I_{zz0}}{\rho LI_p}\right)B_3 = 0 \quad (99) \end{aligned}$$

$$\begin{aligned}
& \left(\frac{\beta_3 \Delta y_{L, m_L}}{\rho L I_p} \right) \{ [\sin(\beta_1)] A_1 + [\cos(\beta_1)] B_1 + [\sinh(\beta_1)] C_1 + [\cosh(\beta_1)] D_1 \} \\
& + \left(\frac{\beta_3 \Delta x_{L, m_L}}{\rho L I_p} \right) \{ [-\sin(\beta_2)] A_2 + [\cos(\beta_2)] B_2 + [-\sinh(\beta_2)] C_2 + [-\cosh(\beta_2)] D_2 \} \\
& + \left[-\frac{\beta_3 I_{zzL}}{\rho L I_p} \sin(\beta_3) + \cos(\beta_3) \right] A_3 + \left[-\frac{\beta_3 I_{zzL}}{\rho L I_p} \cos(\beta_3) - \sin(\beta_3) \right] B_3 = 0
\end{aligned}
\tag{100}$$

In equations (91) through (100), β_1 , β_2 , and β_3 are given by equations (29), (30), and (31), respectively.

Obtaining Nontrivial Solutions

Equations (91) through (100) can be written in vector-matrix form as follows:

$$[Z(\omega)] \begin{bmatrix} A_1 \\ B_1 \\ C_1 \\ D_1 \\ A_2 \\ B_2 \\ C_2 \\ D_2 \\ A_3 \\ B_3 \end{bmatrix} = 0
\tag{101}$$

Where $Z(\omega)$ is the 10×10 coefficient matrix whose entries are functions of ω (see equations (29), (30), and (31) for β_1 , β_2 , and β_3). Nonzero solutions ($A_1, B_1, C_1, D_1, A_2, B_2, C_2, D_2, A_3, B_3$) exist only when the determinant of

$Z(\omega)$ is zero. Therefore, the first step in obtaining nontrivial solutions is to obtain the real solutions of the nonlinear equations:

$$\det[Z(\omega)] = 0 \quad (102)$$

where $\det[]$ denotes the determinant.

A solution ω^* is substituted back into equation (101) and a degenerate system (usually of rank 9) of algebraic equations is obtained. Choosing one coefficient and equating it to an arbitrary value (usually unity) the remaining nine coefficients can be uniquely determined for each solution ω^* . A computer program (BEAM3D), which calculates the nontrivial solutions, is discussed below.

THE COMPUTER PROGRAM

The computer program BEAM3D was written to obtain nontrivial solutions of equations (91) through (100) by the method discussed in the preceding section (see appendix A for a listing). BEAM3D was written assuming a symmetric cross section. Therefore, there is only one bending stiffness $EI = (EI)_x = (EI)_y$. This was done simply because the equations are more accurate for symmetric or, more specifically, circular cross sections. This comes from the assumption used in deriving the governing partial differential equation for torsional vibration (eq. (3)) described in the first section. The only difference between the boundary condition equations used in the computer program and equations (91) through (100) is that $\beta_1 = \beta_2$ in the program (see eqs. (29) and (30) for relationships of β_1 and β_2) since $(EI)_x = (EI)_y$.

The boundary condition equations (91) through (100) are contained in ten separate subroutines named XSHR1, YSHR1, XSHR2, YSHR2, XMOM1, YMOM1, XMOM2, YMOM2, ZMOM1, and ZMOM2, respectively. The large number of trigonometric functions in these equations necessitated the use of additional variable names (for $\sin(\beta)$, $\cosh(\beta)$, etc.).

The solution of equation (102) is computed in subroutine EIGEN. This subroutine obtains values of the determinant of the 10×10 coefficient matrix calculated in the program external function FUNC. EIGEN checks for sign changes in the value of the determinant as well as changes in sign of the slope to find regions of possible roots. Once a region is found that contains a root, the root-solving subprogram SECBI is used to calculate the exact root.

Subroutine SOLVE substitutes the root calculated in "EIGEN" into nine of the original ten boundary condition equations with one of the ten coefficients set equal to one to form a degenerate (rank 9) system. This system is then solved by using the system subprogram GELIM (for Gauss (- Seidel) elimination).

Subroutine PHNORM divides the three mode shape equations by the appropriate factor (i.e., the square-root of the sum of the integrals of the mode shapes squared, integrated from zero to L over the space variable) in order to normalize them. This is useful for obtaining dynamic response to external forces or moments, or in control system studies. The only property of the mode shapes that changes because of normalization is the magnitude.

PROGRAM OPERATION

Input.- A total of 22 input variables is needed to use BEAM3D. Use of a consistent set of units is required (meters-kilograms-seconds or feet-pounds-seconds). A description of each input variable can be found in the listing (see appendix A) in subroutine INNPUT. The only limitation on input is that at least one of the products of inertia I_{xy0} or I_{xyL} must be nonzero to avoid a lower than rank 9 system. This is not really a limitation since the product of inertia couples the three bending modes in the first place.

Output.- The output computed by BEAM3D includes the natural frequency of vibration, the normalized mode shape equations for x- and y- bending and z-axis torsion, and the plots corresponding to these mode shapes. A sample case giving both input and output is given in appendix B.

CONCLUDING REMARKS

A method of obtaining the natural vibration frequencies and mode shapes in three dimensions for a system comprised of a uniform beam with off-centered inertial masses at both extremities has been presented. The equations of motion were derived for this configuration taking into account the kinematic coupling resulting from the product of inertia and the offset end masses. The boundary conditions resulted in a set of nonlinear algebraic equations, the solutions of which yield the modal frequencies and mode shapes for any number of modes. A computer program was presented, which computes the modal frequencies and mode shapes for any desired number of modes. Since the mode shapes are comprised of trigonometric and hyperbolic sine and cosine functions, they can be readily differentiated to obtain the mode-slopes, which are required in control system studies.

APPENDIX A - COMPUTER PROGRAM BEAM3D

```

PROGRAM BEAM3D(INPUT,OUTPUT,TAPE7)
C   PROGRAM BEAM3D CALCULATES THE X-Z PLANE, Y-Z
C   PLANE BENDING AND THE Z AXIS TORSION FOR A BEAM
C   WITH INERTIAL MASSES WITH 'X' AND 'Y' OFFSETS
C   AT BOTH ENDS.
COMMON/BEAM/ROAL,L,EI,M1,M2,IX1,IX2,IY1,IY2,IXY1,IXY2
1,IZ1,IZ2,ROLI,DX1,DX2,DY1,DY2,RHO,G,NMODE
COMMON/TRIGOS/OMEGA1,OMEGA,BTA1,BTA2,SN,CS,SNH,CSH,SN2,CS2
COMMON/SOLS/ A(10),DET,DETSAVE,AMTRX10(10,10),AMTRX9(9,9),
1COLUMN(9,1),DETDIFF
REAL IX1,IX2,IY1,IY2,IXY1,IXY2,IZ1,IZ2,L,M1,M2
EXTERNAL FUNC
C   PSEUDO INITIATES THE PLOTTING ROUTINE
CALL PSEUDO
C   SUBROUTINE ININPUT IS WHERE ALL INPUT VARIABLES
C   ARE SIMPLY WRITTEN IN AS THE TEXT
CALL ININPUT
C   OMEGA1 SETS THE STARTING POINT FOR THE NATURAL
C   FREQUENCY OMEGA1 (RAD/SEC)
OMEGA1=-.01
C   DETSAVE AND DETDIFF ARE USED AS WORK VARIABLES
C   IN SUBROUTINE EIGEN
DETSAVE=1.
DETDIFF=0.
C   NATURAL FREQ'S. AND MODESHAPES ARE FOUND FOR THE
C   FIRST NMODE NUMBER OF MODES
DO 10 I=1,NMODE
5  CALL EIGEN
C   THE NEXT LINE PASSES UP THE TRIVIAL ZERO FREQUENCIES
IF(BTA1.EQ.0.) GO TO 5
CALL SOLVE
CALL NORM(I)
CALL MPLOT
CALL OUTPT(I)
10 CONTINUE
CALL CALPLT(0.,0.,999)
STOP
END

```



```

C          SUBROUTINE EIGEN CALCULATES THE EIGENVALUES OF THE
C          COEFFICIENT MATRIX
C
C          SUBROUTINE EIGEN
COMMON/TRIGOS/OMEGA1,OMEGA,BTA1,BTA2,SN,CS,SNH,CSH,SN2,CS2
COMMON/SOLS/ A(10),DET,DETSAVE,AMTRX10(10,10),AMTRX9(9,9),
1COLUMN(9,1),DETDIFF
COMMON/BEAM/ROAL,L,EI,M1,M2,IX1,IX2,IY1,IY2,IXY1,IXY2
1,IZ1,IZ2,ROLI,DX1,DX2,DY1,DY2,RHO,G,NMODE
DIMENSION EPS(3)
C          FUNC IS THE EXTERNAL THAT CALCULATES THE DETERMINANT
C          OF THE 10 BY 10 COEFFICIENT MATRIX AMTRX10
EXTERNAL FUNC
REAL IX1,IX2,IY1,IY2,IXY1,IXY2,IZ1,IZ2,L,M1,M2
EPS(1)=10**(-8.)
EPS(2)=10**(-12)
EPS(3)=EPS(1)
C          THIS IS WHERE THE FREQUENCY GUESSES ARE INCREMENTED
5  OMEGA1=OMEGA1+0.01
DET=FUNC(OMEGA1)
C          THE FOLLOWING TWO IF-STATEMENTS LOCATE THE AREAS THAT
C          MAY CONTAIN A ROOT (WHERE THE VALUE OF THE DET. CHANGES
C          OR WHERE THE SIGN OF THE SLOPE CHANGES)
IF(DET*DETSAVE.LE.0.) GO TO 10
IF((DETDIFF*(DET-DETSAVE)).LE.0.) GO TO 10
DETDIFF=DET-DETSAVE
DETSAVE=DET
GO TO 5
10  OMEGA2=OMEGA1-.03
DETDIFF=DET-DETSAVE
DETSAVE=DET
C          SECBI IS A ROOT FINDING ROUTINE IN FTNMLIB THAT USES
C          A COMBINED SECANT-INVERSE QUADRATIC INTERPOLATION
C          SAFEGUARDED BY BISECTION . (NOTE: THIS ROUTINE DOES
C          NOT WORK WELL ON DOUBLE ROOTS, IF YOU HAVE DOUBLE
C          ROOTS IT IS ADVISEABLE TO USE A DIFF. ROOT-SOLV. ROUTINE
CALL SECBI(OMEGA2,OMEGA1,.001,FUNC,EPS,ROOT,IERR)

```

```
IF(IERR.EQ.3) WRITE(7,100)
IF(IERR.EQ.8) WRITE(7,200)
IF(IERR.EQ.9) WRITE(7,300)
IF(IERR.EQ.8) GO TO 5
IF(IERR.EQ.9) GO TO 5
100 FORMAT(1X,"SECBI TOOK MORE THAN 50 ITERATIONS TO FIND FREQ")
200 FORMAT(1X,"SECBI WAS GIVEN IMPROPER INITIAL COND'S. SEE VOL.2
1 C2.5")
300 FORMAT(1X,"A ROOT WAS NOT FOUND IN THE INTERVAL GIVEN TO SECBI")
OMEGA=ROOT
CALL TRIG(OMEGA)
RETURN
END
```

C

C
C
C

SUBROUTINE PHNORM CALCULATES THE FACTOR NEEDED TO
NORMALIZE THE MODE SHAPES

```

SUBROUTINE PHNORM(BETA,AC0,AC1,AC2,AC3,ELSQ,PHN,IM)
  B=BETA
  A1=AC1/AC0 $ A2=AC2/AC0 $ A3=AC3/AC0
  S=SIN(B) $ C=COS(B) $ SH=SINH(B) $ CH=COSH(B)
  S2=SIN(2.*B) $ C2=COS(2.*B) $ SH2=SINH(2.*B) $ CH2=COSH(2.*B)
  PHN=(B-S2/2.)/2.+A1**2*(B+S2/2.)/2.+A2**2*(SH2/2.-B)/2.
  1+A3**2*(SH2/2.+B)/2.+A1*(1.-C2)/2.+A2*(S*CH-C*SH)
  2+A3*(S*SH-C*CH+1.)+A1*A2*(C*CH+S*SH-1.)+A1*A3*(C*SH+S*CH)
  3+A2*A3*(CH2-1.)/2.
  PHN=PHN/B
  PHN=SQRT(PHN)*ELSQ*AC0
  WRITE(7,201)PHN
C COMPUTE APPROX. NORM USING SH=CH
  X=B*(1.+(A1+A2)*(A1-A2)+A3**2)/2.
  !-S2*(1.+A1)*(1.-A1)/4.+A1*(1.-C2)/2.+A3-A1*A2-A2*A3/2.
  A23=A2+A3
  Y=SH*A23*(S*(A1+1.)+C*(A1-1.)+A23*SH/2.)
  PHN1=X+Y
  PHN1=SQRT(PHN1/B)*ELSQ*AC0
  WRITE(7,202)PHN1
  IF(IM.GE.6)PHN=PHN1
201 FORMAT(1X,*NORM USING EXACT FORMULA=*,E12.5)
202 FORMAT(1X,*0000APPX NORM PHN1= *,E12.5)
  RETURN
  END

```

C
C

C
C
C

SUBROUTINE NORM DIVIDES ALL COEFFICIENTS BY THE
FACTOR "PHN" WHICH IT RECEIVED FROM PHNORM

```
SUBROUTINE NORM(N)
COMMON/TRIGOS/ OMEGA1, OMEGA, BTA1, BTA2, SN, CS, SNH, CSH, SN2, CS2
COMMON/SOLS/ A(10), DET, DETSAVE, AMTRX10(10,10), AMTRX9(9,9),
1 COLUMN(9,1), DETDIFF
COMMON/BEAM/ROAL, L, EI, M1, M2, IX1, IX2, IY1, IY2, IXY1, IXY2
1, IZ1, IZ2, ROLI, DX1, DX2, DY1, DY2, RHO, G, NMODE
REAL L
ELSQ=SQRT(L)
CALL PHNORM(BTA1, A(1), A(2), A(3), A(4), ELSQ, XPHN, N)
CALL PHNORM(BTA1, A(5), A(6), A(7), A(8), ELSQ, YPHN, N)
B=A(10)/A(9)
ZPHNSQ=A(9)**2*L/BTA2*((B**2+1)*BTA2/2.+(B**2-1)*SIN(2.*BTA2)/4.
1-B*COS(2.*BTA2)/2.+B/2.)
PHN=SQRT(XPHN**2+YPHN**2+ZPHNSQ)
DO 10 K=1,10
A(K)=A(K)/PHN
10 CONTINUE
RETURN
END
```

C
C
C
C
C

SUBROUTINE SOLVE CREATES AND SOLVES THE 9 BY 9
REDUCED COEFFICIENT MATRIX OBTAINED BY CHOOSING
AN ARBITRARY VARIABLE AND DROPPING ONE OF THE
EQUATIONS

C

SUBROUTINE SOLVE
COMMON/BEAM/ROAL,L,EI,M1,M2,IX1,IX2,IY1,IY2,IXY1,IXY2
1,IZ1,IZ2,ROLI,DX1,DX2,DY1,DY2,RHO,G,NMODE
COMMON/SOLS/ A(10),DET,DETSAVE,AMTRX10(10,10),AMTRX9(9,9),
1COLUMN(9,1),DETDIFF
DIMENSION IPIVOT(9),WK(9)
REAL IX1,IX2,IY1,IY2,IXY1,IXY2,IZ1,IZ2,L,M1,M2
NMAX,N,NRHS AND IFAC ARE ALL NEEDED IN GELIM

C

NMAX=9

N=9

NRHS=1

IFAC=0

CALL SET(A)

C

IARB DESIGNATES THE ARBITRARY VARIABLE.

IARB=1

C

ARB DESIGNATES THE VALUE GIVEN TO THE ARBITRARY VARIABLE

ARB=1

A(IARB)--ARB

C

ONE OF THE FOLLOWING 10 EQUATIONS IS COMMENTED

C

SO AS TO BE IGNORED

C

CALL XSHR1(COLUMN(1,1))

CALL XSHR2(COLUMN(1,1))

CALL YSHR1(COLUMN(2,1))

CALL YSHR2(COLUMN(3,1))

CALL XMOM1(COLUMN(4,1))

CALL XMOM2(COLUMN(5,1))

CALL YMOM1(COLUMN(6,1))

CALL YMOM2(COLUMN(7,1))

CALL ZMOM1(COLUMN(8,1))

CALL ZMOM2(COLUMN(9,1))

C

THE FOLLOWING DO-LOOP CALCULATES THE 9BY9 MATRIX

21 DO 10 J=1,10

```

CALL SET(A)
IF(J.EQ.IARB) GO TO 10
K=J
IF(J.GT.IARB) K=K-1
A(J)=1.
C     ONE OF THE FOLLOWING TEN EQUATIONS IS COMMENTED
C     SO AS TO BE IGNORED
C     CALL XSHR1(AMTRX9(1,K))
C     CALL XSHR2(AMTRX9(1,K))
C     CALL YSHR1(AMTRX9(2,K))
C     CALL YSHR2(AMTRX9(3,K))
C     CALL XMOM1(AMTRX9(4,K))
C     CALL XMOM2(AMTRX9(5,K))
C     CALL YMOM1(AMTRX9(6,K))
C     CALL YMOM2(AMTRX9(7,K))
C     CALL ZMOM1(AMTRX9(8,K))
C     CALL ZMOM2(AMTRX9(9,K))
10  CONTINUE
C     SUBROUTINE GELIM IS IN FTMMLIB AND SOLVES N BY N MATRICES **
CALL GELIM(NMAX,N,AMTRX9,NRHS,COLUMN,IPIVOT,IFAC,WK,IERR)
WRITE(7,101) IERR
101 FORMAT(2X,"IERR IS",2X,I3)
C     THE FOLLOWING LOOP ASSIGNS THE VALUES FOUND FOR THE
C     9 NON-ARBITRARY VARIABLES FOUND IN GELIM IN ADDITION
C     TO THE ONE ARBITRARY VARIABLE TO THE ORIGINAL ARRAY "A(10)
DO 20 I=1,10
IF(I.EQ.IARB) GO TO 30
IF(I.GT.IARB) GO TO 40
A(I)=COLUMN(I,1)
GO TO 20
30  A(I)=ARB
GO TO 20
40  A(I)=COLUMN(I-1,1)
20  CONTINUE
RETURN
END

```

C

C
C
C

SUBROUTINE MPLOTT FORMS THE PLOTS OF THE THREE
INDEPENDANT MODE SHAPES FOR EACH MODE

```
SUBROUTINE MPLOTT
COMMON/SOLS/ A(10),DET,DETSAVE,AMTRX10(10,10),AMTRX9(9,9)
1,COLUMN(9,1)
COMMON/TRIGOS/OMEGA1,OMEGA,BTA1,BTA2,SN,CS,SNH,CSH,SN2,CS2
DIMENSION XLAB(3),YLAB(3),XUER(3),YUER(3),TORLAB(3),TORUER(3)
XLAB(1)=10HTHE XZ-PLA
XLAB(2)=10HNE MODE SH
XLAB(3)=10HAPE (E)
XUER(1)=10HX DISPLACE
XUER(2)=10HMENT RX(E)
XUER(3)=10H
YLAB(1)=10HTHE YZ-PLA
YLAB(2)=10HNE MODE SH
YLAB(3)=10HAPE (E)
YUER(1)=10HY DISPLACE
YUER(2)=10HMENT RY(E)
YUER(3)=10H
TORLAB(1)=10HTORSIONAL
TORLAB(2)=10HMODE SHAPE
TORLAB(3)=10H (E)
TORUER(1)=10HANGULAR DI
TORUER(2)=10HSPLACEMENT
TORUER(3)=10H (E)
CALL CRUNCH(A(1),A(2),A(3),A(4),XLAB,XUER,BTA1)
CALL CRUNCH(A(5),A(6),A(7),A(8),YLAB,YUER,BTA1)
CALL CRUNCH(A(9),A(10),0.,0.,TORLAB,TORUER,BTA2)
RETURN
END
```

C
C
C

SUBROUTINE CRUNCH USES INFOPLT TO GENERATE PLOTS
FOR M PLOT OF EACH INDEPENDANT SUB-MODE

C
C

SUBROUTINE CRUNCH(A,B,C,D,HLABEL,ULABEL,BTA)
DIMENSION HLABEL(3),ULABEL(3),BTA(1),EPSLN(1010),R(1010)
JJ=1

DLTX IS THE INCREMENT ADDED TO EPSLN TO OBTAIN
POINTS FOR THE PLOT OF THE MODE SHAPE
DLTX=.001

C
C
C
C

IEC,N,KX,KY,XMIN,XMAX,YMIN,YMAX,PCTPTS,NXMC,NYMC,
ISYM,SX,SY,XOFF AND YOFF ARE ALL VARIABLES NEEDED
IN INFOPLT.

IEC=1
N=1001
KX=1
KY=1
XMIN=0.0
XMAX=1.
YMIN=-.03
YMAX=.03
PCTPTS=0.00
NXMC=30
NYMC=30
ISYM=0
SX=7.
SY=5.
XOFF=.75
YOFF=.75

C
C
C

EPSLN(JJ) IS THE HORIZONTAL COMPONENT OF THE PLOT
WHERE AS R(K) IS THE VERTICAL.
EPSLN(1)=0.
DO 20 K=1,N
R(K)=A*SIN(BTA(1)*EPSLN(JJ))+B*COS(BTA(1)*EPSLN(JJ))+C*SINH(BTA(1)
1*EPSLN(JJ))+D*COSH(BTA(1)*EPSLN(JJ))

```
1*EPSLN(JJ))+D*COSH(BTA(1)*EPSLN(JJ))
5  EPSLN(JJ+1)=EPSLN(JJ)+DLTX
   JJ=JJ+1
20 CONTINUE
   CALL INFOPLT(IEC,N,EPSLN(1),KX,R(1),KY,XMIN,XMAX,YMIN,YMAX,
1PCTPTS,NXMC,HLABEL,NYMC,ULABEL,ISYM,SX,SY,XOFF,YOFF)
   RETURN
   END
```

C
C
C

SUBROUTINE TRIG FINDS VALUES OF THE TRIGONOMETRIC
FUNCTIONS. IT DOES THIS ONCE FOR EACH VALUE OF OMEGA.

```
SUBROUTINE TRIG(DLTA)
COMMON/BEAM/ROAL,L,EI,M1,M2,IX1,IX2,IY1,IY2,IXY1,IXY2
1,IZ1,IZ2,ROLI,DX1,DX2,DY1,DY2,RHO,G,NMODE
COMMON/TRIGOS/OMEGA1,OMEGA,BTA1,BTA2,SN,CS,SNH,CSH,SN2,CS2
REAL IX1,IX2,IY1,IY2,IXY1,IXY2,IZ1,IZ2,L,M1,M2
BTA1=(ROAL/EI*DLTA**2*L**3)**.25
BTA2=DLTA*L*(RHO/G)**.5
SN=SIN(BTA1)
CS=COS(BTA1)
SNH=SINH(BTA1)
CSH=COSH(BTA1)
SN2=SIN(BTA2)
CS2=COS(BTA2)
RETURN
END
```

C
C

FUNC CALCULATES THE DETERMINANT OF THE 10 BY 10 MATRIX

```

FUNCTION FUNC(DUM2)
COMMON/BEAM/ROAL,L,EI,M1,M2,IX1,IX2,IY1,IY2,IXY1,IXY2
1,IZ1,IZ2,ROLI,DX1,DX2,DY1,DY2,RHO,G,NMODE
COMMON/SOLS/ A(10),DET,DETSAVE,AMTRX10(10,10),AMTRX9(9,9)
1,COLUMN(9,1)
DIMENSION B(10),IPIVOT(10),WK(10)
REAL IX1,IX2,IY1,IY2,IXY1,IXY2,IZ1,IZ2,L,M1,M2
NMAX=10
N=10
IDET=2
CALL TRIG(DUM2)
DO 10 I=1,10
CALL SET(A)
A(I)=1.
CALL XSHR1(B(1))
CALL XSHR2(B(2))
CALL YSHR1(B(3))
CALL YSHR2(B(4))
CALL XMOM1(B(5))
CALL XMOM2(B(6))
CALL YMOM1(B(7))
CALL YMOM2(B(8))
CALL ZMOM1(B(9))
CALL ZMOM2(B(10))
DO 20 J=1,10
AMTRX10(J,I)=B(J)
20 CONTINUE
10 CONTINUE

```

C

DETFAC IS A DETERMINANT FINDING ROUTINE

C

```

CALL DETFAC(NMAX,N,AMTRX10,IPIVOT,IDET,DUM,ISCALE,WK,IERR)
FUNC=DUM*(10**(10*ISCALE))
WRITE(7,222) DUM2,FUNC,ISCALE
222 FORMAT(2X,E14.7,4X,E14.7,4X,I2)
RETURN
END

```

C
C
C

SUBROUTINE SET IS USED TO SET ALL THE COEFFICIENTS
OF THE MODE SHAPE EQUATIONS EQUAL TO ZERO

```
SUBROUTINE SET(A)
  DIMENSION A(10)
  REAL IX1,IX2,IY1,IY2,IXY1,IXY2,IZ1,IZ2,L,M1,M2
  DO 10 I=1,10
  A(I)=0.
10 CONTINUE
  RETURN
  END
```

C

C
C
C
C

SUBROUTINE XSHR1 CONTAINS THE BOUNDARY CONDITION
DESCRIBING THE SHEAR FORCE IN THE X-DIRECTION AT
THE END Z=0.

```

SUBROUTINE XSHR1(UX1)
COMMON/BEAM/ROAL,L,EI,M1,M2,IX1,IX2,IY1,IY2,IXY1,IXY2
1,IZ1,IZ2,ROLI,DX1,DX2,DY1,DY2,RHO,G,NMODE
COMMON/TRIGOS/OMEGA1,OMEGA,BTA1,BTA2,SN,CS,SNH,CSH,SN2,CS2
COMMON/SOLS/ A(10),DET,DETSAVE,AMTRX10(10,10),AMTRX9(9,9),
1COLUMN(9,1),DETDIFF
REAL IX1,IX2,IY1,IY2,IXY1,IXY2,IZ1,IZ2,L,M1,M2
UX1=-BTA1**4*(-A(10)*DY1+A(4)+A(2))*M1/ROAL+A(3)*BTA1**3-A(1)*BTA
1 1**3
RETURN
END

```

C
C
C
C
C

SUBROUTINE XSHR2 CONTAINS THE BOUNDARY CONDITION
DESCRIBING THE SHEAR FORCE IN THE X-DIRECTION AT
THE END Z=L.

```

SUBROUTINE XSHR2(UX2)
COMMON/SOLS/ A(10),DET,DETSAVE,AMTRX10(10,10),AMTRX9(9,9),
1COLUMN(9,1),DETDIFF
COMMON/BEAM/ROAL,L,EI,M1,M2,IX1,IX2,IY1,IY2,IXY1,IXY2
1,IZ1,IZ2,ROLI,DX1,DX2,DY1,DY2,RHO,G,NMODE
COMMON/TRIGOS/OMEGA1,OMEGA,BTA1,BTA2,SN,CS,SNH,CSH,SN2,CS2
REAL IX1,IX2,IY1,IY2,IXY1,IXY2,IZ1,IZ2,L,M1,M2
UX2=((A(4)*BTA1**3*ROAL+A(3)*BTA1**4*M2)*SNH-A(9)*BTA1**4*DY2*M2
1 *SN2+(A(2)*BTA1**3*ROAL+A(1)*BTA1**4*M2)*SN+(A(3)*BTA1**3*CSH-
2 A(1)*BTA1**3*CS)*ROAL+(-A(10)*BTA1**4*CS2*DY2+A(4)*BTA1**4*CSH+
3 A(2)*BTA1**4*CS)*M2)/ROAL
RETURN
END

```

C
C
C
C

SUBROUTINE YSHR1 CONTAINS THE BOUNDARY CONDITION
DESCRIBING THE SHEAR FORCE IN THE Y-DIRECTION AT
THE END Z=0.

```
SUBROUTINE YSHR1(UY1)
COMMON/SOLS/ A(10),DET,DETSAVE,AMTRX10(10,10),AMTRX9(9,9),
1COLUMN(9,1),DETDIFF
COMMON/BEAM/ROAL,L,EI,M1,M2,IX1,IX2,IY1,IY2,IXY1,IXY2
1,IZ1,IZ2,ROLI,DX1,DX2,DY1,DY2,RHO,G,NMODE
COMMON/TRIGOS/OMEGA1,OMEGA,BTA1,BTA2,SN,CS,SNH,CSH,SN2,CS2
REAL IX1,IX2,IY1,IY2,IXY1,IXY2,IZ1,IZ2,L,M1,M2
UY1=-BTA1**4*(A(10)*DX1+A(8)+A(6))*M1/ROAL+A(7)*BTA1**3-A(5)*BTA1
1 **3
RETURN
END
```

C
C
C
C
C
C

SUBROUTINE YSHR2 CONTAINS THE BOUNDARY CONDITION
DESCRIBING THE SHEAR FORCE IN THE Y-DIRECTION AT
THE END Z=L.

```
SUBROUTINE YSHR2(UY2)
COMMON/SOLS/ A(10),DET,DETSAVE,AMTRX10(10,10),AMTRX9(9,9),
1COLUMN(9,1),DETDIFF
COMMON/BEAM/ROAL,L,EI,M1,M2,IX1,IX2,IY1,IY2,IXY1,IXY2
1,IZ1,IZ2,ROLI,DX1,DX2,DY1,DY2,RHO,G,NMODE
COMMON/TRIGOS/OMEGA1,OMEGA,BTA1,BTA2,SN,CS,SNH,CSH,SN2,CS2
REAL IX1,IX2,IY1,IY2,IXY1,IXY2,IZ1,IZ2,L,M1,M2
UY2=((A(8)*BTA1**3*ROAL+A(7)*BTA1**4*M2)*SNH+A(9)*BTA1**4*DX2*M2
1 *SN2+(A(6)*BTA1**3*ROAL+A(5)*BTA1**4*M2)*SN+(A(7)*BTA1**3*CSH-
2 A(5)*BTA1**3*CS)*ROAL+(A(10)*BTA1**4*CS2*DX2+A(8)*BTA1**4*CSH+
3 A(6)*BTA1**4*CS)*M2)/ROAL
RETURN
END
```

C
C
C

SUBROUTINE XMOM1 CONTAINS THE BOUNDARY CONDITION
DESCRIBING THE MOMENT ABOUT THE X-AXIS AT Z=0.

```

SUBROUTINE XMOM1(MX1)
COMMON/SOLS/ A(10),DET,DETSAVE,AMTRX10(10,10),AMTRX9(9,9),
1COLUMN(9,1),DETDIFF
COMMON/BEAM/ROAL,L,EI,M1,M2,IX1,IX2,IY1,IY2,IXY1,IXY2
1,IZ1,IZ2,ROLI,DX1,DX2,DY1,DY2,RHO,G,NMODE
COMMON/TRIGOS/OMEGA1,OMEGA,BTA1,BTA2,SN,CS,SNH,CSH,SN2,CS2
REAL IX1,IX2,IY1,IY2,IXY1,IXY2,IZ1,IZ2,L,M1,M2,MX1
MX1= BTA1**4*((A(7)*BTA1+A(5)*BTA1)*IX1-(A(3)*BTA1+A(1)*BTA1)*I
1 XY1)/(L**2*ROAL)+A(8)*BTA1**2-A(6)*BTA1**2
RETURN
END

```

C
C
C
C
C

SUBROUTINE XMOM2 CONTAINS THE BOUNDARY CONDITION
DESCRIBING THE MOMENT ABOUT THE X-AXIS AT Z=L.

```

SUBROUTINE XMOM2(MX2)
COMMON/SOLS/ A(10),DET,DETSAVE,AMTRX10(10,10),AMTRX9(9,9),
1COLUMN(9,1),DETDIFF
COMMON/BEAM/ROAL,L,EI,M1,M2,IX1,IX2,IY1,IY2,IXY1,IXY2
1,IZ1,IZ2,ROLI,DX1,DX2,DY1,DY2,RHO,G,NMODE
COMMON/TRIGOS/OMEGA1,OMEGA,BTA1,BTA2,SN,CS,SNH,CSH,SN2,CS2
REAL IX1,IX2,IY1,IY2,IXY1,IXY2,IZ1,IZ2,L,M1,M2,MX2
MX2= BTA1**4*(IXY2*(A(4)*BTA1*SNH-A(2)*BTA1*SN+A(3)*BTA1*CSH+A(1)
1 *BTA1*CS)-IX2*(A(8)*BTA1*SNH-A(6)*BTA1*SN+A(7)*BTA1*CSH+A(5)*
2 BTA1*CS))/(L**2*ROAL)+A(7)*BTA1**2*SNH-A(5)*BTA1**2*SN+A(8)*BTA
3 1**2*CSH-A(6)*BTA1**2*CS
RETURN
END

```

C
C
C

SUBROUTINE YMOM1 CONTAINS THE BOUNDARY CONDITION
DESCRIBING THE MOMENT ABOUT THE Y-AXIS AT Z=0.

```
SUBROUTINE YMOM1(MY1)
COMMON/SOLS/ A(10),DET,DETSAVE,AMTRX10(10,10),AMTRX9(9,9),
1COLUMN(9,1),DETDIFF
COMMON/BEAM/ROAL,L,EI,M1,M2,IX1,IX2,IY1,IY2,IXY1,IXY2
1,IZ1,IZ2,ROLI,DX1,DX2,DY1,DY2,RHO,G,NMODE
COMMON/TRIGOS/OMEGA1,OMEGA,BTA1,BTA2,SN,CS,SNH,CSH,SN2,CS2
REAL IX1,IX2,IY1,IY2,IXY1,IXY2,IZ1,IZ2,L,M1,M2,MY1
MY1=BTA1**4*((A(3)*BTA1+A(1)*BTA1)*IY1-(A(7)*BTA1+A(5)*BTA1)*IX
1 Y1)/(L**2*ROAL)+A(4)*BTA1**2-A(2)*BTA1**2
RETURN
END
```

C
C
C
C
C

SUBROUTINE YMOM2 CONTAINS THE BOUNDARY CONDITION
DESCRIBING THE MOMENT ABOUT THE Y-AXIS AT Z=L.

```
SUBROUTINE YMOM2(MY2)
COMMON/SOLS/ A(10),DET,DETSAVE,AMTRX10(10,10),AMTRX9(9,9),
1COLUMN(9,1),DETDIFF
COMMON/BEAM/ROAL,L,EI,M1,M2,IX1,IX2,IY1,IY2,IXY1,IXY2
1,IZ1,IZ2,ROLI,DX1,DX2,DY1,DY2,RHO,G,NMODE
COMMON/TRIGOS/OMEGA1,OMEGA,BTA1,BTA2,SN,CS,SNH,CSH,SN2,CS2
REAL IX1,IX2,IY1,IY2,IXY1,IXY2,IZ1,IZ2,L,M1,M2,MY2
MY2=BTA1**4*(IXY2*(A(8)*BTA1*SNH-A(6)*BTA1*SN+A(7)*BTA1*CSH+A(5)
1 *BTA1*CS)-IY2*(A(4)*BTA1*SNH-A(2)*BTA1*SN+A(3)*BTA1*CSH+A(1)*B
2 TA1*CS))/(L**2*ROAL)+A(3)*BTA1**2*SNH-A(1)*BTA1**2*SN+A(4)*BTA1
3 **2*CSH-A(2)*BTA1**2*CS
RETURN
END
```

C
C
C

SUBROUTINE ZMOM1 CONTAINS THE BOUNDARY CONDITION
DESCRIBING THE MOMENT ABOUT THE Z-AXIS AT Z=0.

```

SUBROUTINE ZMOM1(MZ1)
COMMON/SOLS/ A(10),DET,DETSAVE,AMTRX10(10,10),AMTRX9(9,9),
1COLUMN(9,1),DETDIFF
COMMON/BEAM/ROAL,L,EI,M1,M2,IX1,IX2,IY1,IY2,IXY1,IXY2
1,IZ1,IZ2,ROLI,DX1,DX2,DY1,DY2,RHO,G,NMODE
COMMON/TRIGOS/OMEGA1,OMEGA,BTA1,BTA2,SN,CS,SNH,CSH,SN2,CS2
REAL IX1,IX2,IY1,IY2,IXY1,IXY2,IZ1,IZ2,L,M1,M2,MZ1
MZ1 = BTA2**2*((A(8)+A(6))*DX1*M1/ROLI-(A(4)+A(2))*DY1*M1/ROLI+A(1
1  0)*IZ1/ROLI)+A(9)*BTA2
RETURN
END

```

C
C
C
C
C

SUBROUTINE ZMOM2 CONTAINS THE BOUNDARY CONDITIONS
DESCRIBING THE MOMENT ABOUT THE Z-AXIS AT Z=L.

```

SUBROUTINE ZMOM2(MZ2)
COMMON/SOLS/ A(10),DET,DETSAVE,AMTRX10(10,10),AMTRX9(9,9),
1COLUMN(9,1),DETDIFF
COMMON/BEAM/ROAL,L,EI,M1,M2,IX1,IX2,IY1,IY2,IXY1,IXY2
1,IZ1,IZ2,ROLI,DX1,DX2,DY1,DY2,RHO,G,NMODE
COMMON/TRIGOS/OMEGA1,OMEGA,BTA1,BTA2,SN,CS,SNH,CSH,SN2,CS2
REAL IX1,IX2,IY1,IY2,IXY1,IXY2,IZ1,IZ2,L,M1,M2,MZ2
MZ2--((A(7)*BTA2**2*DX2-A(3)*BTA2**2*DY2)*M2*SNH+(A(10)*BTA2*ROLI+
1A(9)*BTA2**2*IZ2)*SN2+(A(5)*BTA2**2*DX2-A(1)*BTA2**2*DY2)*M2*SN-A
2  (9)*BTA2*CS2*ROLI+((A(8)*BTA2**2*CSH+A(6)*BTA2**2*CS)*DX2+(-A(4)
3  *BTA2**2*CSH-A(2)*BTA2**2*CS)*DY2)*M2+A(10)*BTA2**2*CS2*IZ2)/R
4  OLI
RETURN
END

```

SUBROUTINE ININPUT
 COMMON/BEAM/ROAL,L,EI,M1,M2,IX1,IX2,IY1,IY2,IXY1,IXY2
 1,IZ1,IZ2,ROLI,DX1,DX2,DY1,DY2,RHO,G,NMODE
 REAL IX1,IX2,IY1,IY2,IXY1,IXY2,IZ1,IZ2,L,M1,M2
 C "ROAL" IS THE MASS OF THE BEAM ALONE.
 ROAL=12.42
 C "L" IS THE LENGTH OF THE BEAM.
 L=130.
 C "EI" IS THE BENDING STIFFNESS OF THE BEAM (SYMMETRICAL)
 EI=4.*10**7.
 C "M1" IS THE MASS OF THE LUMPED MASS AT Z=0. ON THE BEAM
 M1=6366.46
 C "M2" IS THE MASS OF THE LUMPED MASS AT Z=L ON THE BEAM
 M2=12.42
 C IX1 AND IX2 ARE THE MOMENTS OF INERTIA ABOUT THE
 C X-AXIS AT Z=0. AND L RESPECTIVELY
 IX1=905443.0
 IX2=18000.
 C IY1 AND IY2 ARE THE MOMENTS OF INERTIA ABOUT THE
 C Y-AXIS AT Z=0. AND L RESPECTIVELY
 IY1=6789100.
 IY2=9336.
 C IXY1 AND IXY2 ARE THE PRODUCTS OF INERTIA AT Z=0,L RESP.
 IXY1=0.0
 IXY2=-7570.
 C IZ1 AND IZ2 ARE THE MOMENTS OF INERTIA ABOUT THE
 C Z-AXIS AT Z=0.,L RESPECTIVELY
 IZ1=7086601.
 IZ2=27407.
 C "PI" IS THE POLAR MOMENT OF INERTIA ABOUT THE Z-AXIS
 PI=.1738
 C "RHO" IS THE DENSITY OF THE BEAM.
 RHO=.9089/PI
 ROLI=RHO*L*PI
 C DX1 AND DY1 ARE THE X AND Y DISPLACEMENTS OF THE POINT

```
C      MASS AT Z=0. DX2 AND DY2 ARE THE SAME FOR Z=L.
      DX1=0.0
      DY1=0.0
      DX2=18.75
      DY2=-32.5
C      'G' IS THE MODULUS OF RIDGIDITY
      G=4.E+7/PI
C      NMODE SPECIFIES THE NUMBER OF MODES TO BE SOLVED FOR
      NMODE=5
      WRITE(7,100) ROAL,L,EI,M1,M2,IX1,IX2,IY1,IY2,IXY1,IXY2,IZ1,IZ2
1,ROLI,DX1,DX2,DY1,DY2,RHO,G
100  FORMAT(1X,'THE BEAM CHARACTERISTICS ARE',/,
11X,'MASS=',E14.7,/,1X,'LENGTH=',E14.7,/,1X,'STIFFNESS=',E14.7,/,
21X,'M1=',E14.7,/,1X,'M2=',E14.7,/,1X,'IX1=',E14.7,/,1X,'IX2=',E1
34.7,/,1X,'IY1=',E14.7,/,1X,'IY2=',E14.7,/,1X,'IXY1=',E14.7,/,1X,
4'IXY2=',E14.7,/,1X,'IZ1=',E14.7,/,1X,'IZ2=',E14.7,/,1X,'RH*XL*IP='
5,E14.7,/,1X,'DX1=',E14.7,/,1X,'DX2=',E14.7,/,1X,'DY1=',E14.7,/,1X
6,'DY2=',E14.7,/,1X,'DENSITY=',E14.7,/,1X,'G=',E14.7)
      RETURN
      END
```

```

SUBROUTINE OUTPT(I)
COMMON/BEAM/ROAL,L,EI,M1,M2,IX1,IX2,IY1,IY2,IXY1,IXY2
1,IZ1,IZ2,ROLI,DX1,DX2,DY1,DY2,RHO,G,NMODE
COMMON/TRIGOS/OMEGA1,OMEGA,BTA1,BTA2,SN,CS,SNH,CSH,SN2,CS2
COMMON/SOLS/ A(10),DET,DETSAVE,AMTRX10(10,10),AMTRX9(9,9)
1,COLUMN(9,1)
REAL IX1,IX2,IY1,IY2,IXY1,IXY2,IZ1,IZ2,L,M1,M2
OMEGAHZ=OMEGA/(2.*3.1415926)
WRITE(7,10) I,OMEGAHZ
10  FORMAT(1X,"THE SOLUTION FOR MODE  ",I2,///,2X,"THE FREQUENCY OF
1  VIBRATION IS",E14.7)
WRITE(7,20) (A(J),J=1,4)
20  FORMAT(1X,"THE XZ-PLANE MODE SHAPE IS ",/,2X,E14.7,"*SIN(BETA1*X/L
1)+",E14.7,"*COS(BETA1*XZ/L)+",/,2X,E14.7,"*SINH(BETA1*XZ/L)+",E14.7,
2"*COSH(BETA1*XZ/L)")
WRITE(7,30) (A(J),J=5,8)
30  FORMAT(1X,"THE YZ-PLANE MODE SHAPE IS ",//,2X,E14.7,"*SIN(BETA1*X/
1L)+",E14.7,"*COS(BETA1*XZ/L)+",/,
22X,E14.7,"*SINH(BETA1*XZ/L)+",E14.7,"*COSH(BETA1*XZ/L)")
WRITE(7,40) (A(J),J=9,10)
40  FORMAT(1X,"THE TORSIONAL MODE SHAPE IS ",//,2X,E14.7,"*SIN(BETA2*X
1/L)+",E14.7,"*COS(BETA2*XZ/L)")
WRITE(7,50) BTA1,BTA2
50  FORMAT(1X,"BETA1=",E14.7,/,1X,"BETA2=",E14.7)
RETURN
END

```

C
C
C

APPENDIX B - SAMPLE CASE USING BEAM3D

Figure B-1 shows the Spacecraft Control Lab Experiment or SCOLE (ref. 1) configuration, which is the system to be analyzed in this test case. The following list contains all the parameters of the SCOLE geometry needed by the computer program BEAM3D:

Mass of Space Shuttle = $m_0 = 6366.46$ slugs

Mass of Reflector = $m_L = 12.42$ slugs

Length of Beam = $L = 130$ feet

Inertias of Shuttle
at the Attachment Point

$$\left\{ \begin{array}{l} I_{xx0} = 905,443 \text{ slug-ft}^2 \\ I_{yy0} = 6,789,100 \text{ slug-ft}^2 \\ I_{zz0} = 7,086,601 \text{ slug-ft}^2 \\ I_{xy0} = 0 \text{ slug-ft}^2 \end{array} \right.$$

Inertias of Reflector
at the Attachment Point

$$\left\{ \begin{array}{l} I_{xxL} = 18,000 \text{ slug-ft}^2 \\ I_{yyL} = 9,336 \text{ slug-ft}^2 \\ I_{zzL} = 27,407 \text{ slug-ft}^2 \\ I_{xyL} = 7,570 \text{ slug-ft}^2 \end{array} \right.$$

Shuttle CM Location

$$\left\{ \begin{array}{l} \Delta x_0 = 0. \text{ ft.} \\ \Delta y_0 = 0. \text{ ft.} \end{array} \right.$$

Reflector CM Location

$$\left\{ \begin{array}{l} \Delta x_L = 18.75 \text{ ft.} \\ \Delta y_L = 32.5 \text{ ft.} \end{array} \right.$$

Material Properties

$$\left\{ \begin{array}{l} \rho A = .09554 \text{ slugs/ft} \\ EI = 4. \times 10^7 \text{ lb-ft}^2 \\ \rho I_p = .9089 \text{ slug-ft} \\ GI_p = 4. \times 10^7 \text{ lb-ft}^2 \end{array} \right.$$

SPACECRAFT CONTROL LAB EXPERIMENT (SCOLE)

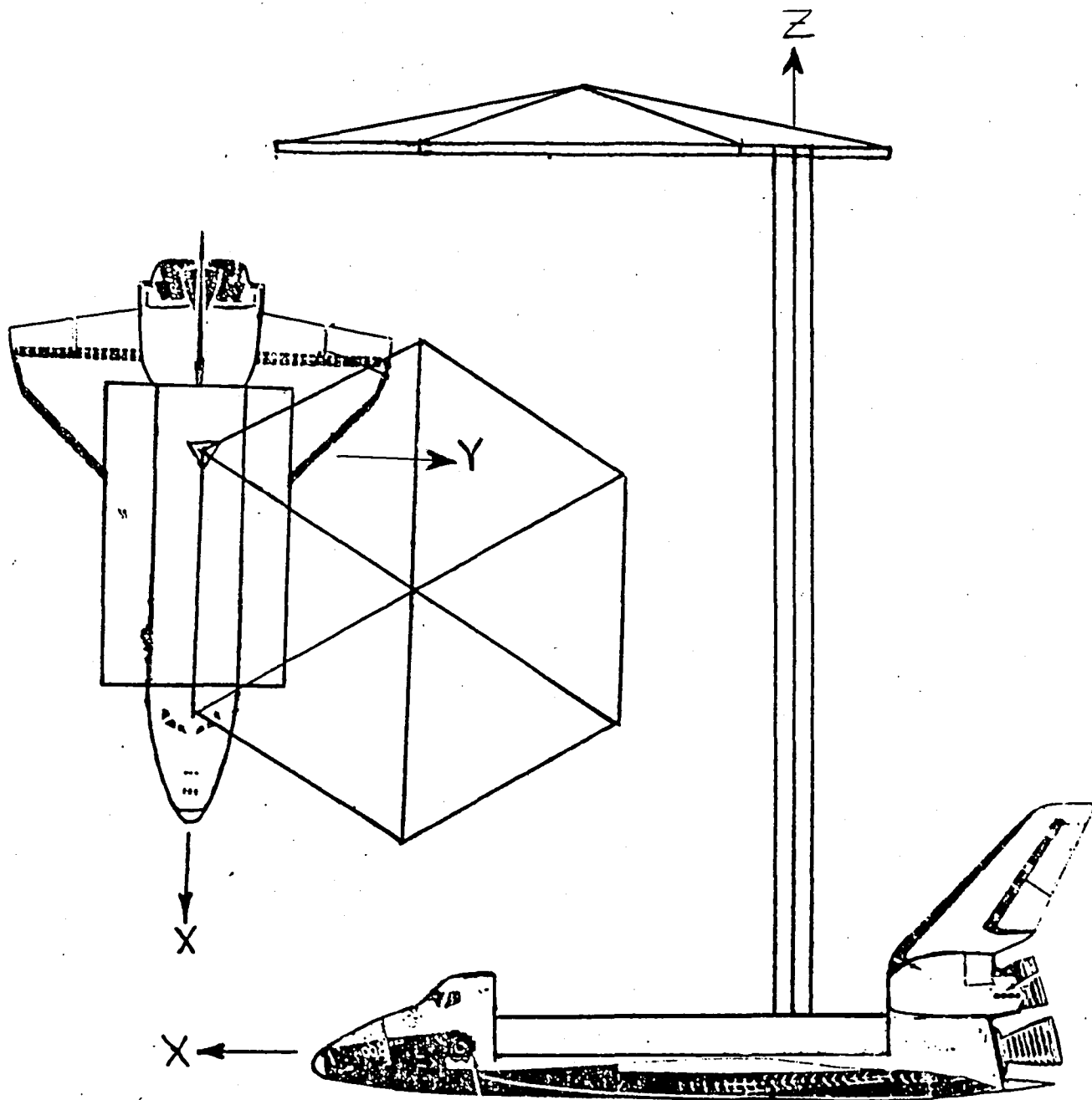

Figure B-1: Drawing of the SCOLE, Shuttle/Antenna Configuration modelled for the Sample Case

THE SOLUTION FOR MODE 1

THE FREQUENCY OF VIBRATION IS .2740493E+00 HZ.

THE XZ-PLANE MODE SHAPE IS

$$\begin{aligned} &.1616907E+00*\text{SIN}(\text{BETA1}*Z/L)+ -.1964167E+00*\text{COS}(\text{BETA1}*Z/L)+ \\ &-.1688419E+00*\text{SINH}(\text{BETA1}*Z/L)+ .1958759E+00*\text{COSH}(\text{BETA1}*Z/L) \end{aligned}$$

THE YZ-PLANE MODE SHAPE IS

$$\begin{aligned} &-.3957009E-01*\text{SIN}(\text{BETA1}*Z/L)+ .6906827E-01*\text{COS}(\text{BETA1}*Z/L)+ \\ &.5842914E-01*\text{SINH}(\text{BETA1}*Z/L)+ -.6890796E-01*\text{COSH}(\text{BETA1}*Z/L) \end{aligned}$$

THE TORSIONAL MODE SHAPE IS

$$-.3199889E-01*\text{SIN}(\text{BETA2}*Z/L)+ .1581162E-04*\text{COS}(\text{BETA2}*Z/L)$$

BETA1= .1192552E+01

BETA2= .3374271E-01

Figure B-2a: Natural Frequency and Mode Shapes calculated
by BEAM3D for Mode #1.

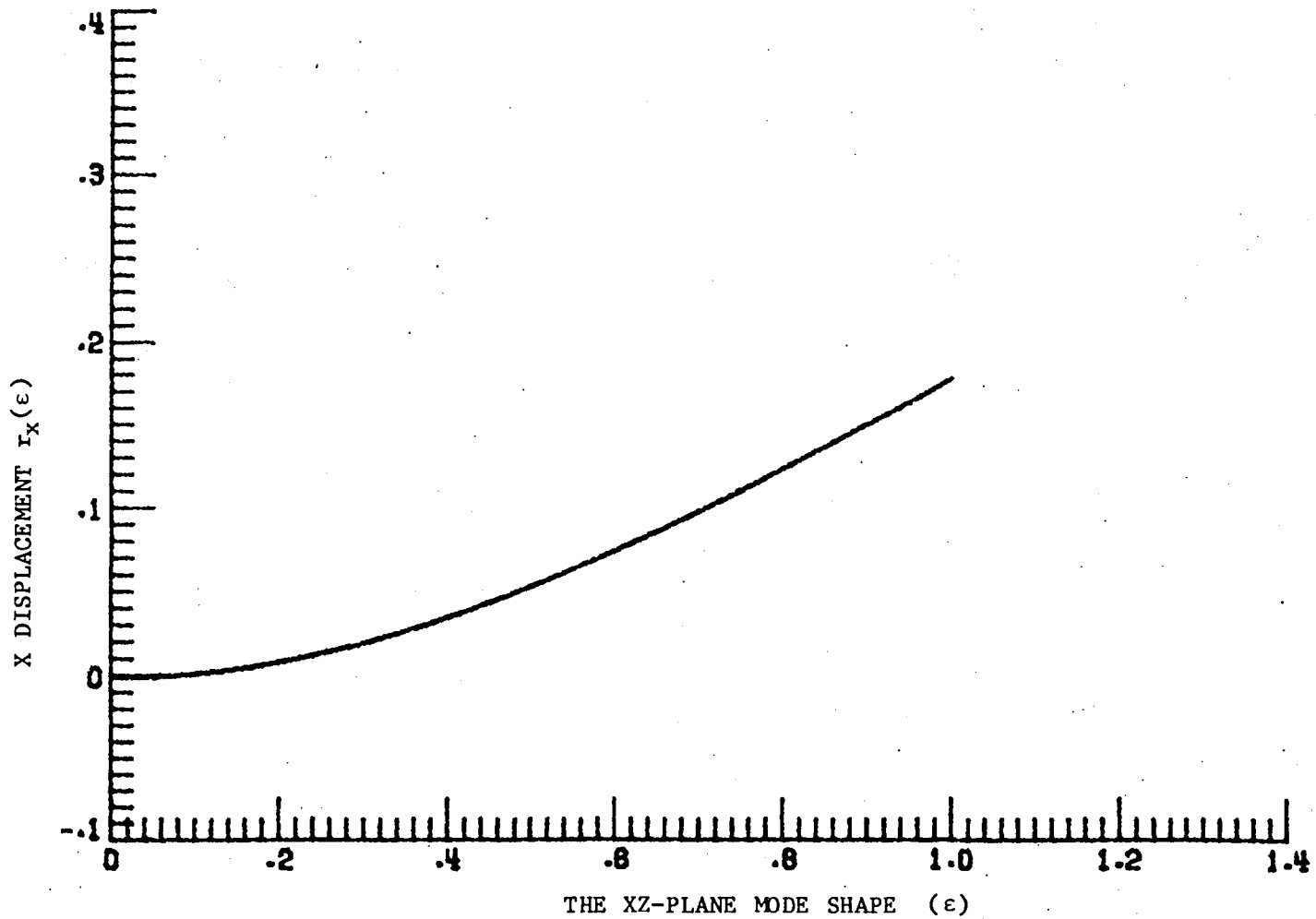

Figure B-2b: Projection of the first mode shape, calculated using BEAM3D, onto the xz-plane where the displacement r_x is plotted versus the nondimensional position variable ϵ .

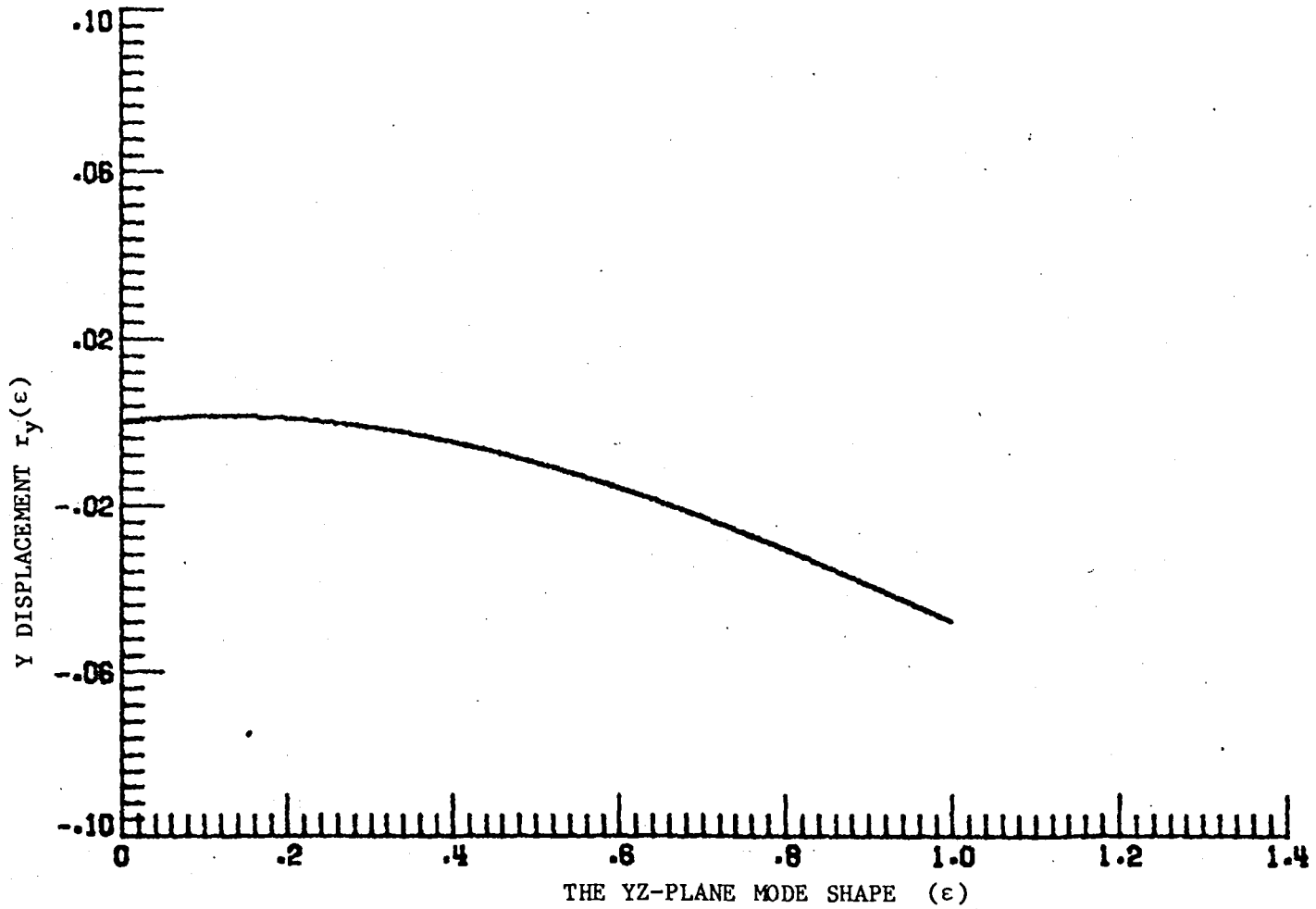

Figure B-2c: Projection of the first mode shape, calculated using BEAM3D, onto the yz-plane where the displacement r_y is plotted versus the nondimensional position variable ϵ .

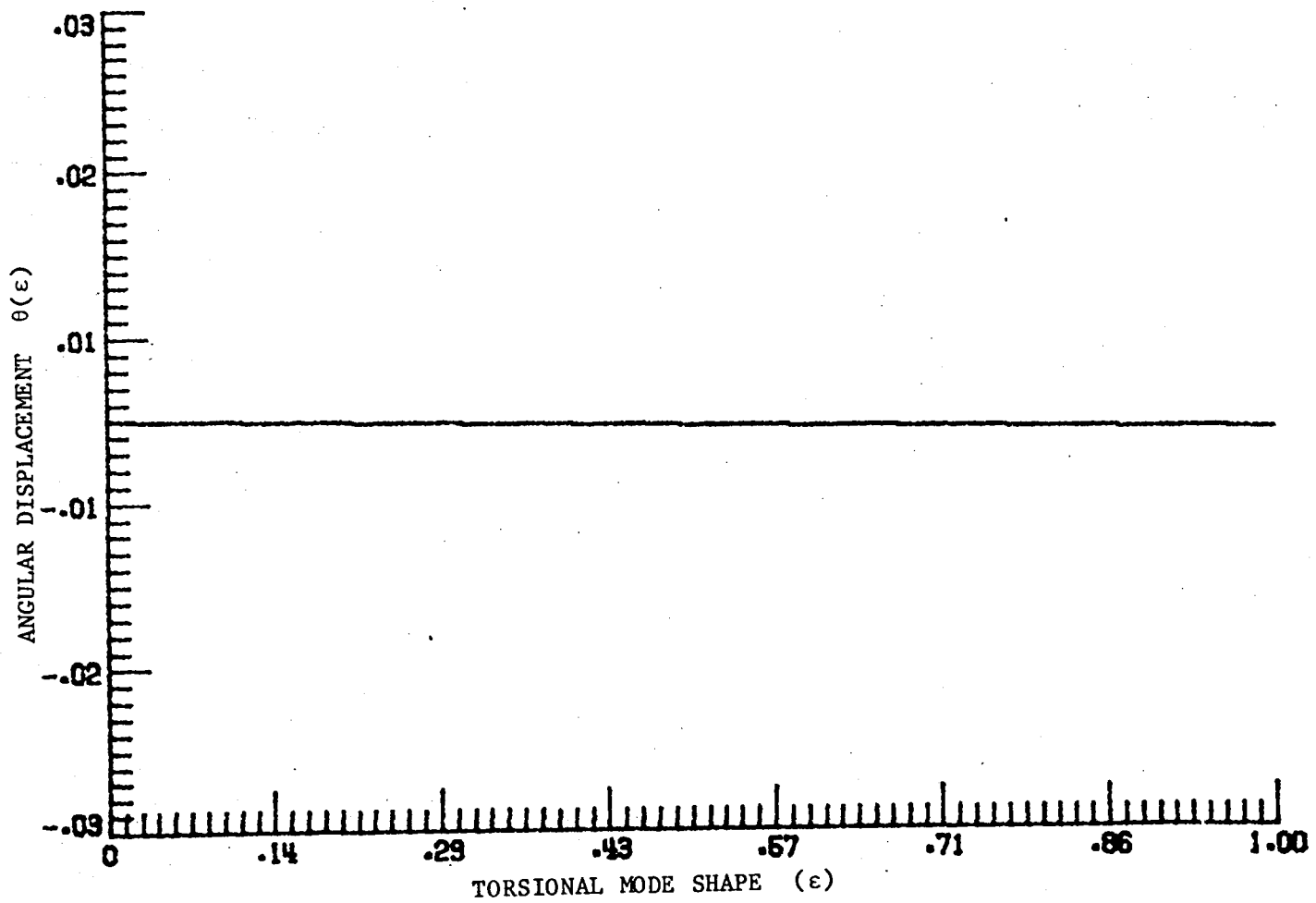

Figure B-2d: The torsional deflection of the first mode shape, calculated using BEAM3D, where θ (in rad.) is plotted versus the nondimensional position variable ϵ .

THE SOLUTION FOR MODE 2

THE FREQUENCY OF VIBRATION IS .3229025E+00 HZ.

THE XZ-PLANE MODE SHAPE IS

$$\begin{aligned} &.7265880E-01 * \sin(\text{BETA1} * Z / L) + -.8441782E-01 * \cos(\text{BETA1} * Z / L) + \\ &-.7506201E-01 * \sinh(\text{BETA1} * Z / L) + .8419519E-01 * \cosh(\text{BETA1} * Z / L) \end{aligned}$$

THE YZ-PLANE MODE SHAPE IS

$$\begin{aligned} &.1257088E+00 * \sin(\text{BETA1} * Z / L) + -.1965677E+00 * \cos(\text{BETA1} * Z / L) + \\ &-.1676755E+00 * \sinh(\text{BETA1} * Z / L) + .1961255E+00 * \cosh(\text{BETA1} * Z / L) \end{aligned}$$

THE TORSIONAL MODE SHAPE IS

$$.2599605E-02 * \sin(\text{BETA2} * Z / L) + -.1090200E-05 * \cos(\text{BETA2} * Z / L)$$

BETA1 = .1294490E+01

BETA2 = .3975783E-01

Figure B-3a: Natural Frequency and Mode Shapes calculated
by BEAM3D for Mode #2.

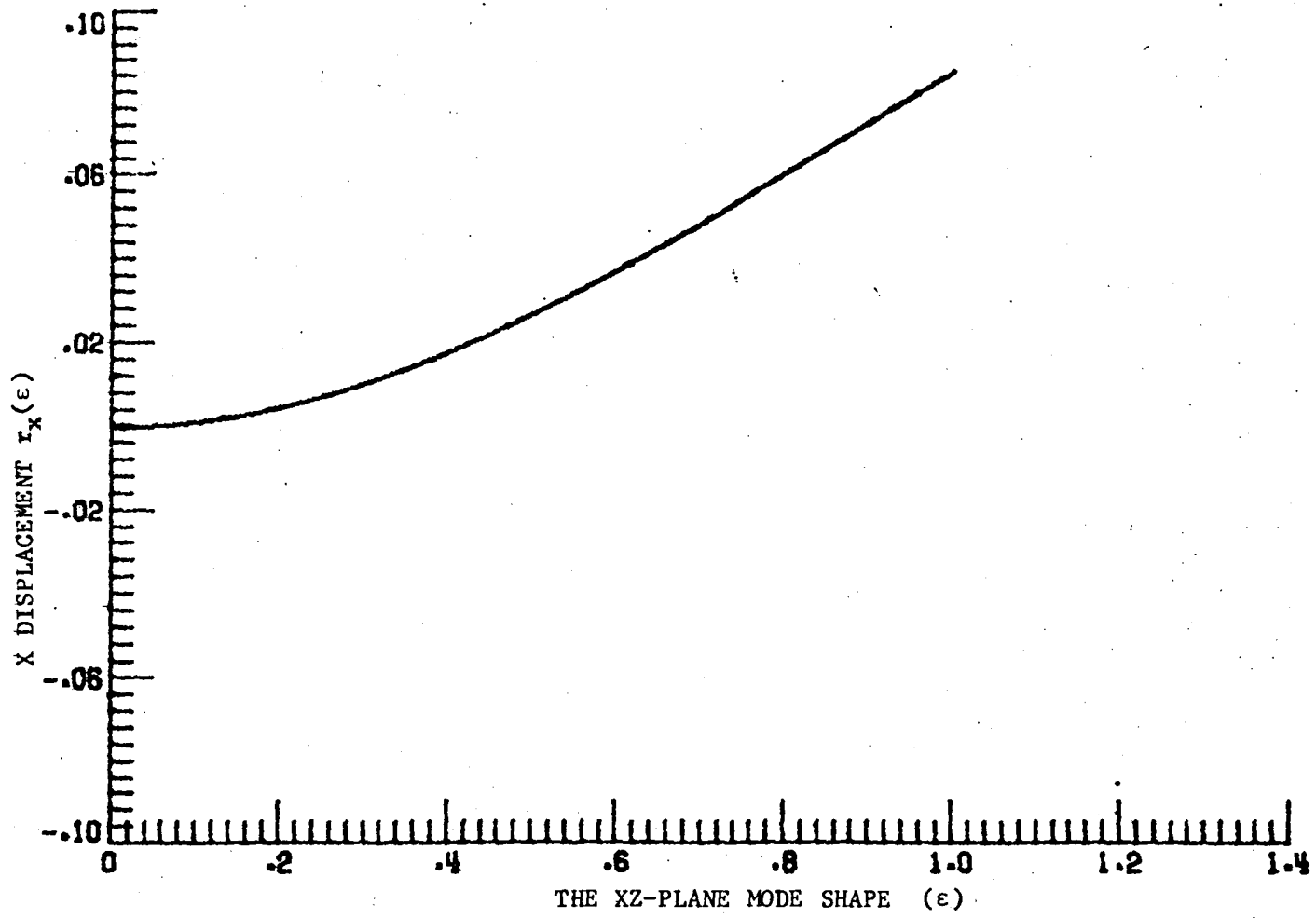

Figure B-3b: Projection of the second mode shape onto the xz-plane where the displacement r_x is plotted versus the nondimensional position variable ϵ .

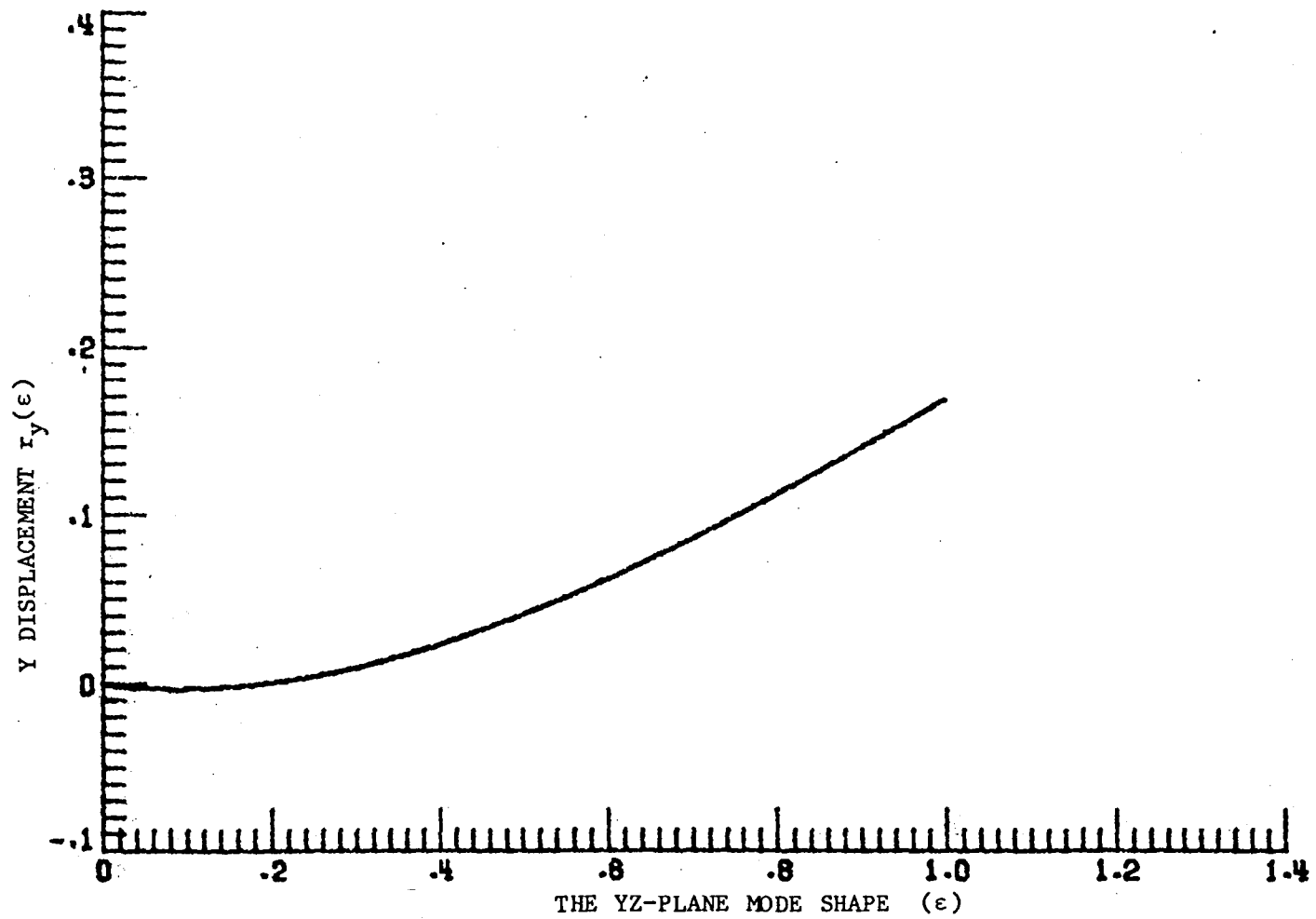

Figure B-3c: Projection of the second mode shape onto the yz-plane where the displacement r_y is plotted versus the nondimensional position variable ϵ .

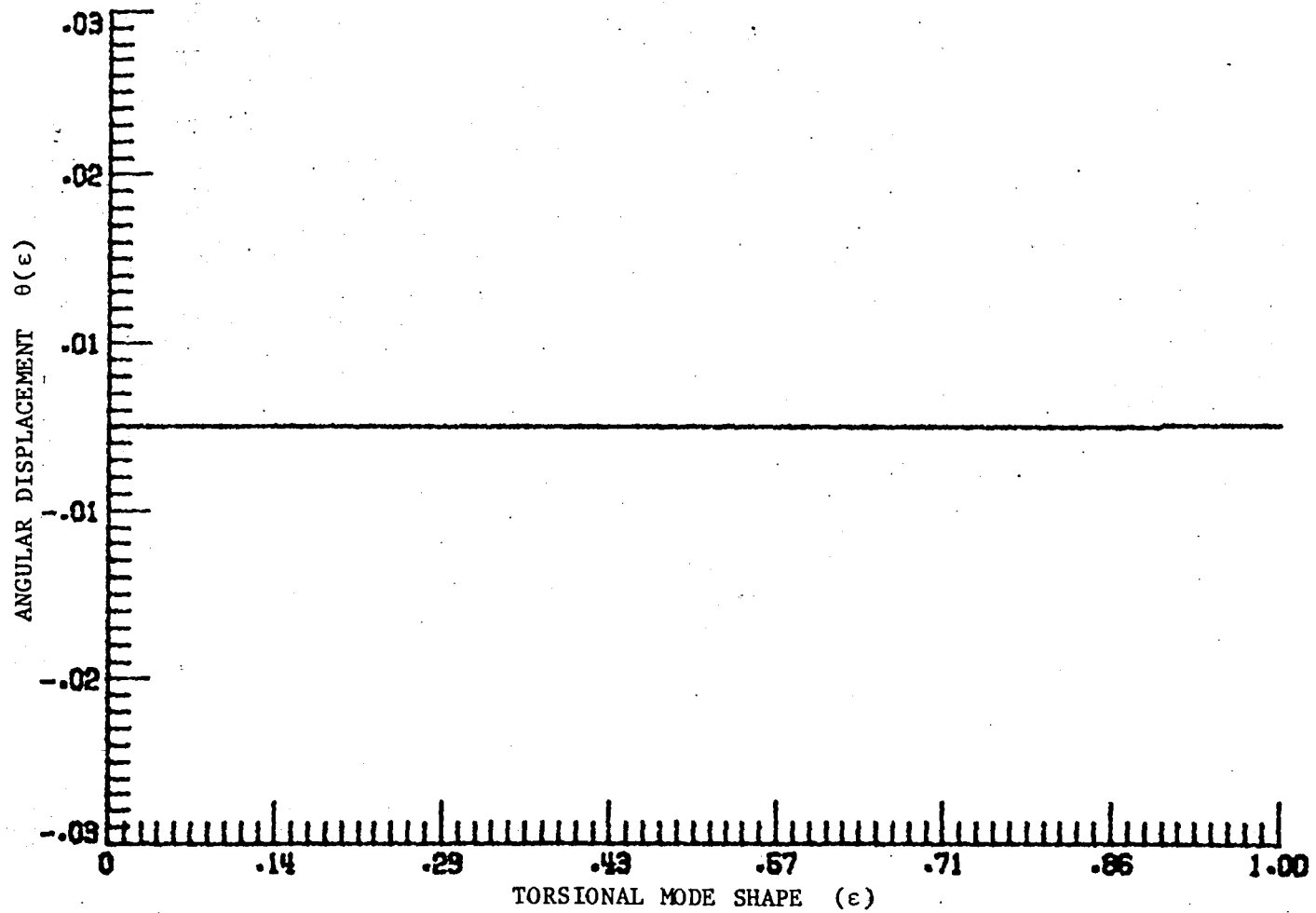

Figure B-3d: The torsional twist of the second mode shape where θ (in rad.) is plotted versus the nondimensional position variable ϵ .

THE SOLUTION FOR MODE 3

THE FREQUENCY OF VIBRATION IS .7487723E+00 HZ.

THE XZ-PLANE MODE SHAPE IS

$$.2297884E-01 * \sin(\text{BETA1} * Z / L) + -.5911988E-01 * \cos(\text{BETA1} * Z / L) + \\ -.2345591E-01 * \sinh(\text{BETA1} * Z / L) + .5907393E-01 * \cosh(\text{BETA1} * Z / L)$$

THE YZ-PLANE MODE SHAPE IS

$$.2543413E-01 * \sin(\text{BETA1} * Z / L) + .3262716E-02 * \cos(\text{BETA1} * Z / L) + \\ -.2523513E-01 * \sinh(\text{BETA1} * Z / L) + -.3312861E-02 * \cosh(\text{BETA1} * Z / L)$$

THE TORSIONAL MODE SHAPE IS

$$.7256298E-01 * \sin(\text{BETA2} * Z / L) + -.1312307E-04 * \cos(\text{BETA2} * Z / L)$$

BETA1 = .1971232E+01

BETA2 = .9219366E-01

Figure B-4a: Natural Frequency and Mode Shapes calculated by BEAM3D for Mode #3.

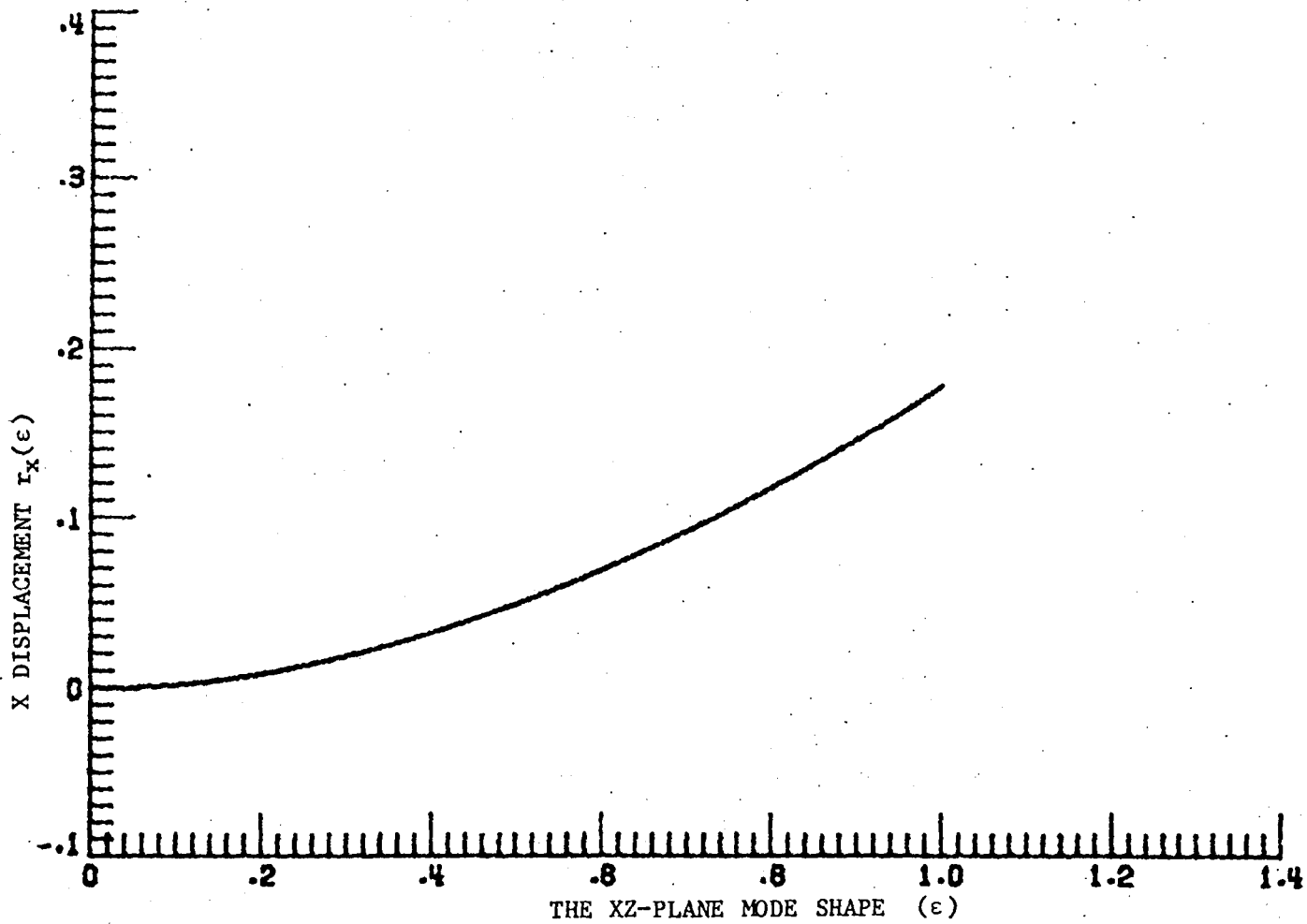

Figure B-4b: Projection of the third mode shape onto the xz-plane where the displacement r_x is plotted versus the nondimensional position variable ϵ .

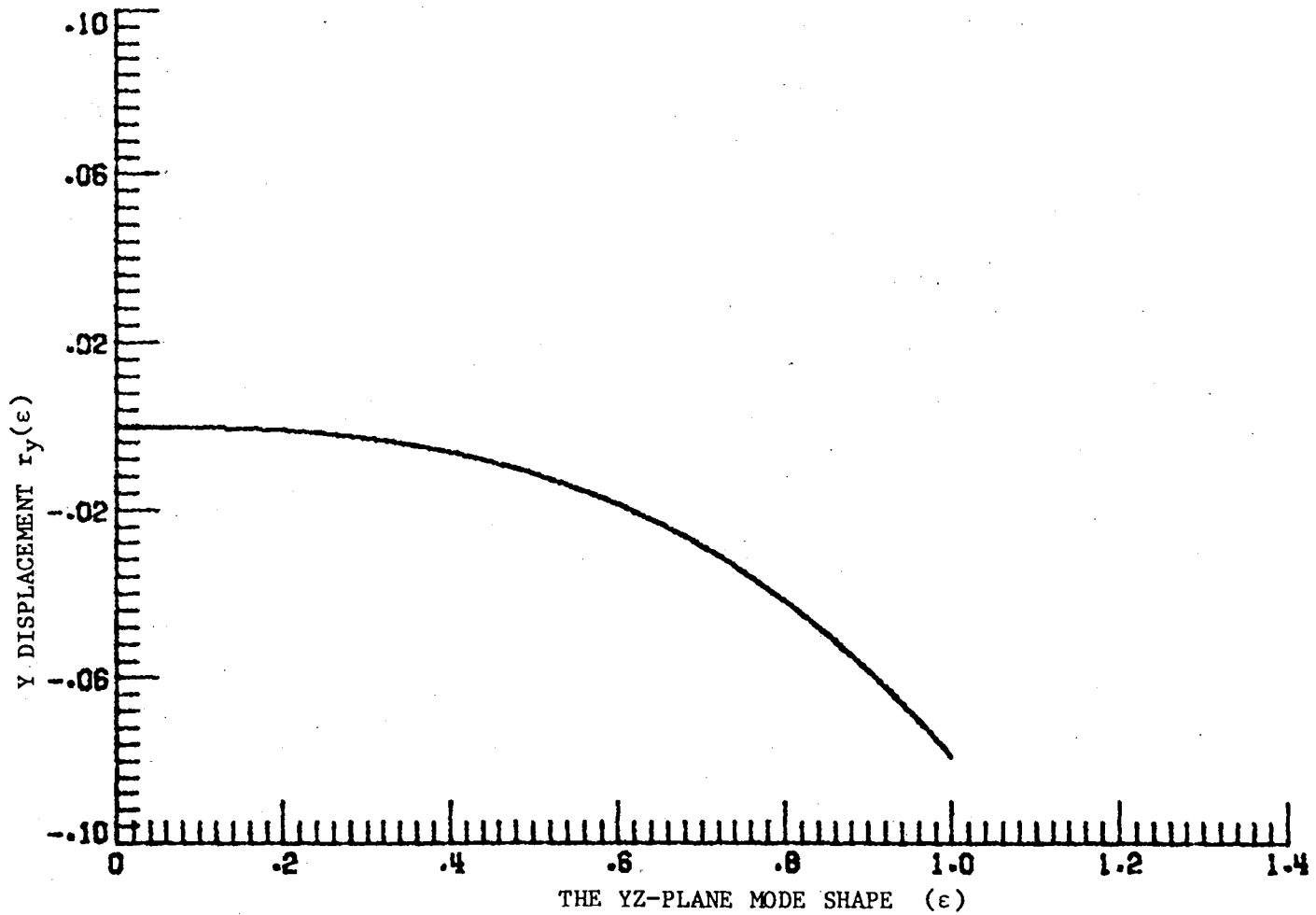

Figure B-4c: Projection of the third mode shape onto the yz-plane where the displacement r_y is plotted versus the nondimensional position variable ϵ .

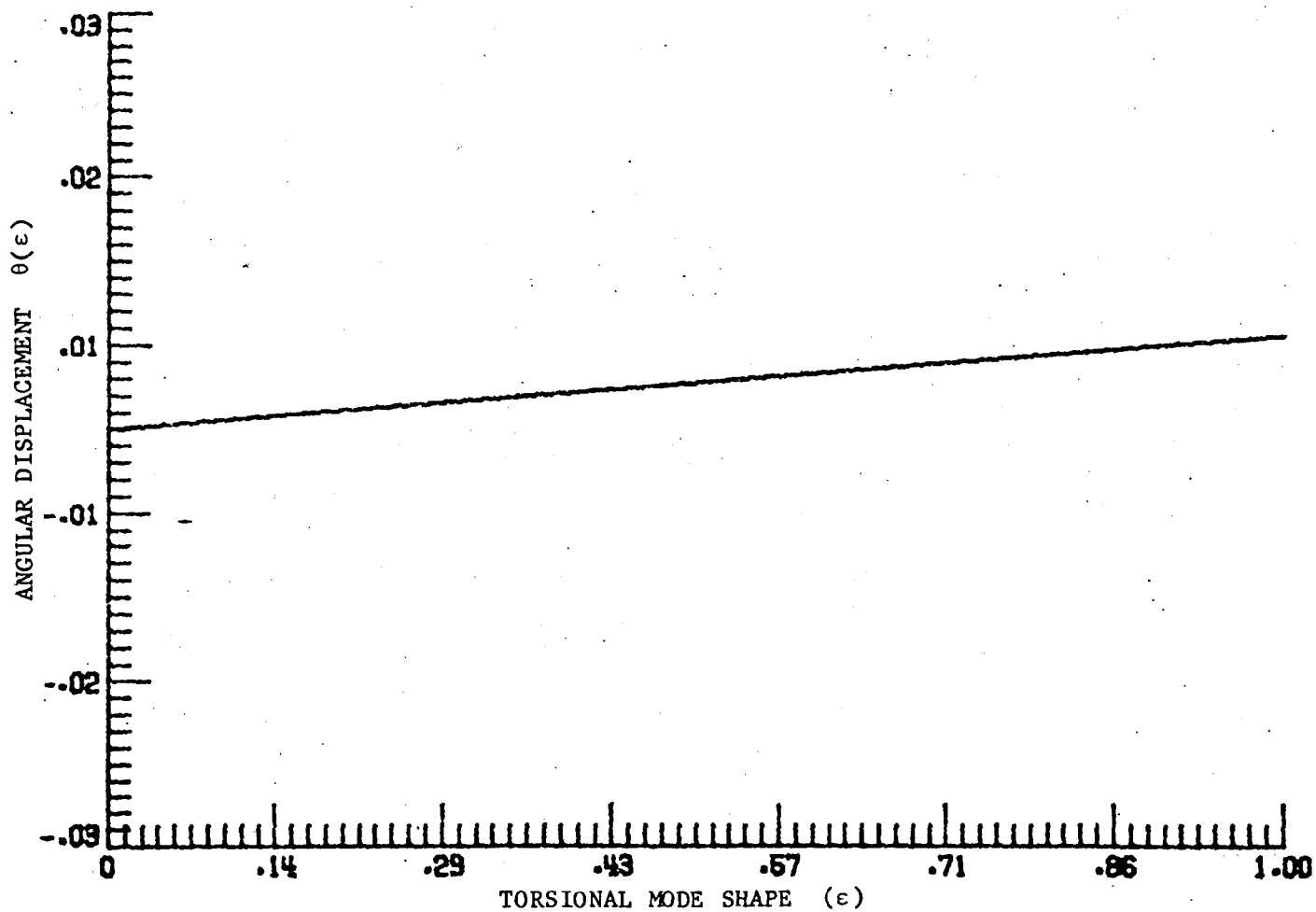

Figure B-4d: The torsional deflection of the third mode shape where θ (in rad.) is plotted versus the nondimensional position variable ϵ .

THE SOLUTION FOR MODE 4

THE FREQUENCY OF VIBRATION IS .1244013E+01 HZ.

THE XZ-PLANE MODE SHAPE IS

$$\begin{aligned} &.6875555E-01 * \sin(\text{BETA1} * Z / L) + -.6385600E-01 * \cos(\text{BETA1} * Z / L) + \\ &-.6899607E-01 * \sinh(\text{BETA1} * Z / L) + .6375024E-01 * \cosh(\text{BETA1} * Z / L) \end{aligned}$$

THE YZ-PLANE MODE SHAPE IS

$$\begin{aligned} &-.1050247E+00 * \sin(\text{BETA1} * Z / L) + .9400610E-01 * \cos(\text{BETA1} * Z / L) + \\ &.1076795E+00 * \sinh(\text{BETA1} * Z / L) + -.9384279E-01 * \cosh(\text{BETA1} * Z / L) \end{aligned}$$

THE TORSIONAL MODE SHAPE IS

$$.1139082E-01 * \sin(\text{BETA2} * Z / L) + -.1239939E-05 * \cos(\text{BETA2} * Z / L)$$

BETA1 = .2540828E+01

BETA2 = .1531709E+00

Figure B-5a: Natural Frequency and Mode Shapes calculated
by BEAM3D for Mode #4.

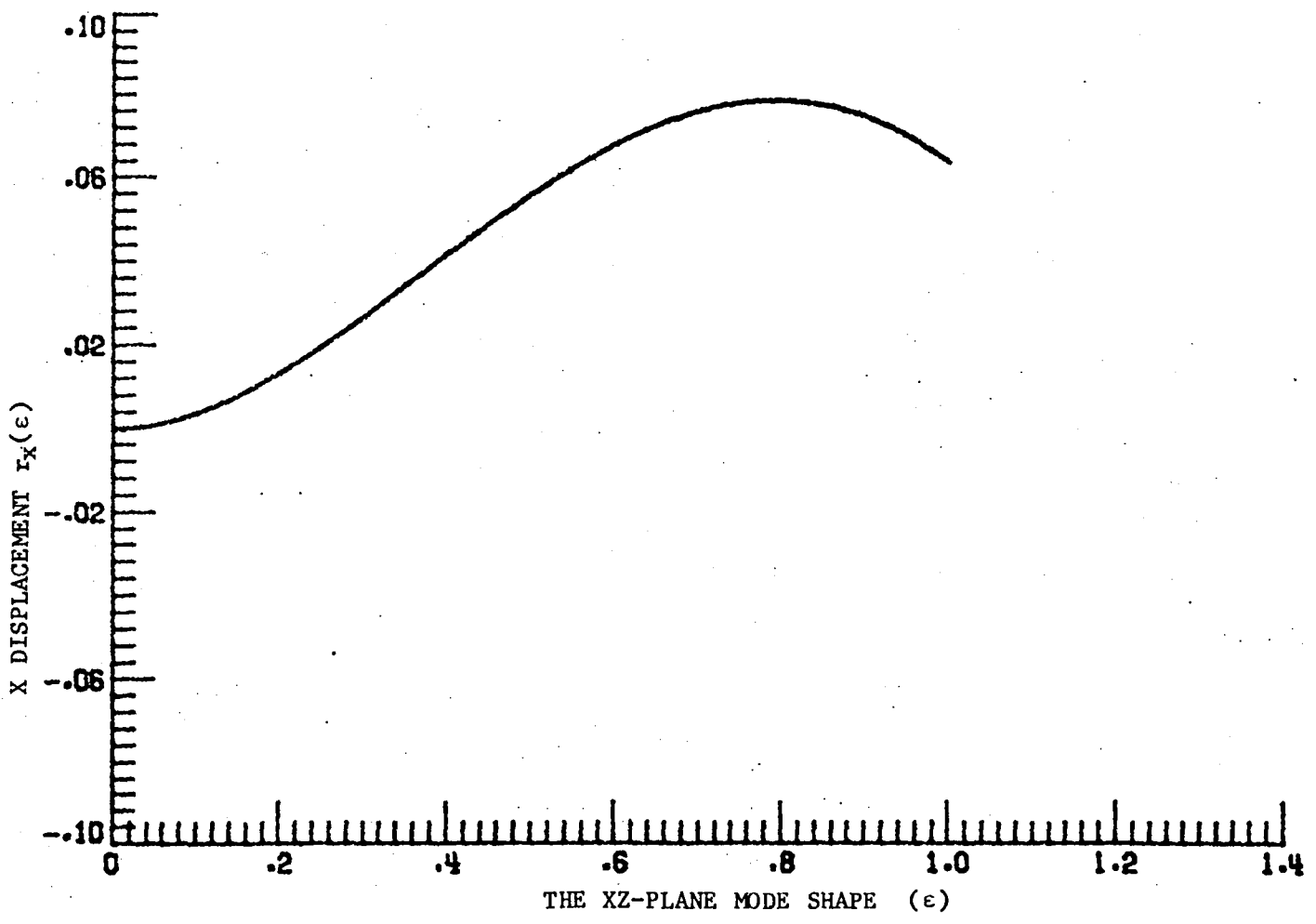

Figure B-5b: Projection of the fourth mode shape onto the xz-plane where the displacement r_x is plotted versus the nondimensional position variable ϵ .

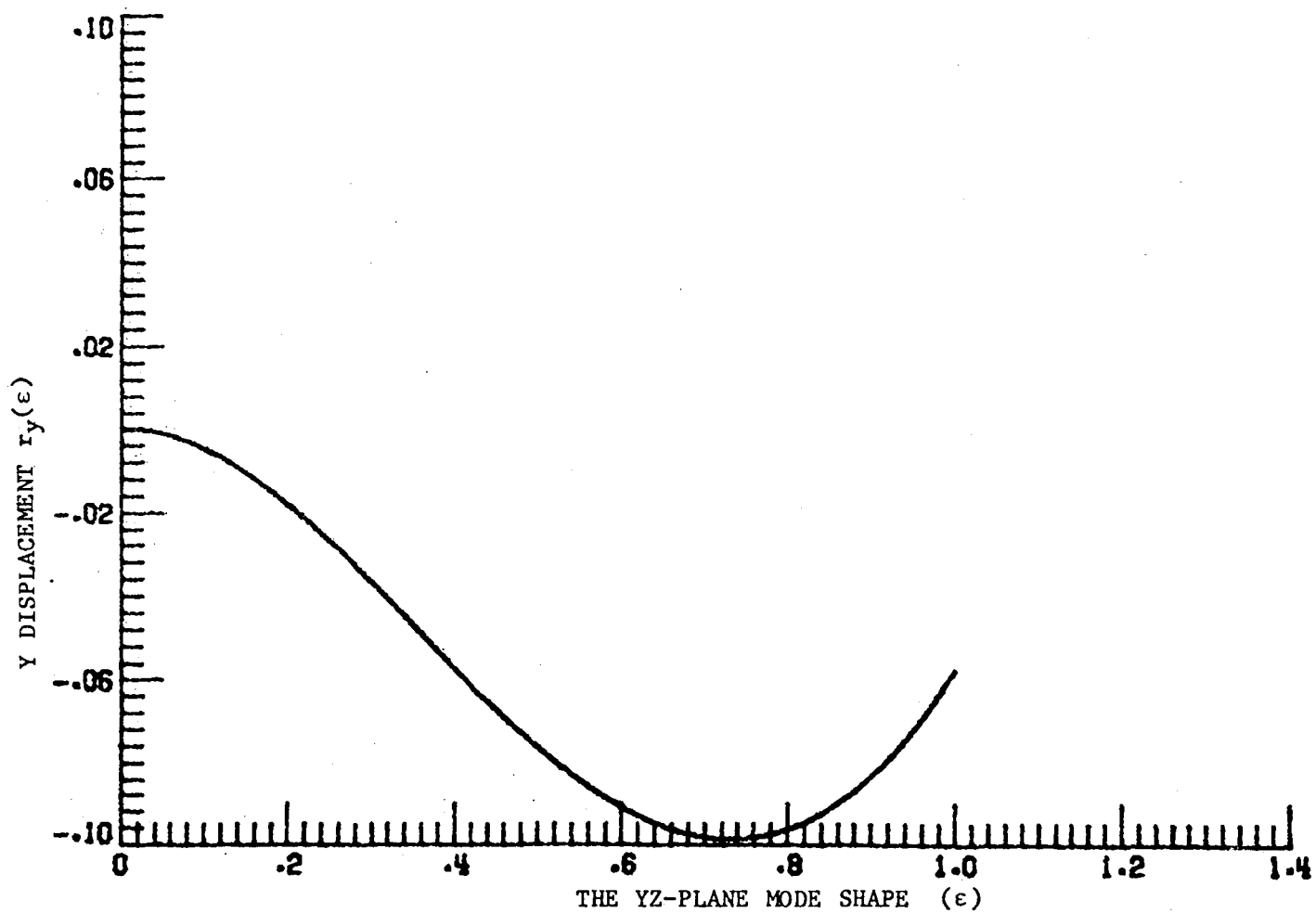

Figure B-5c: Projection of the fourth mode shape onto the yz-plane where the displacement r_y is plotted versus the nondimensional position variable ϵ .

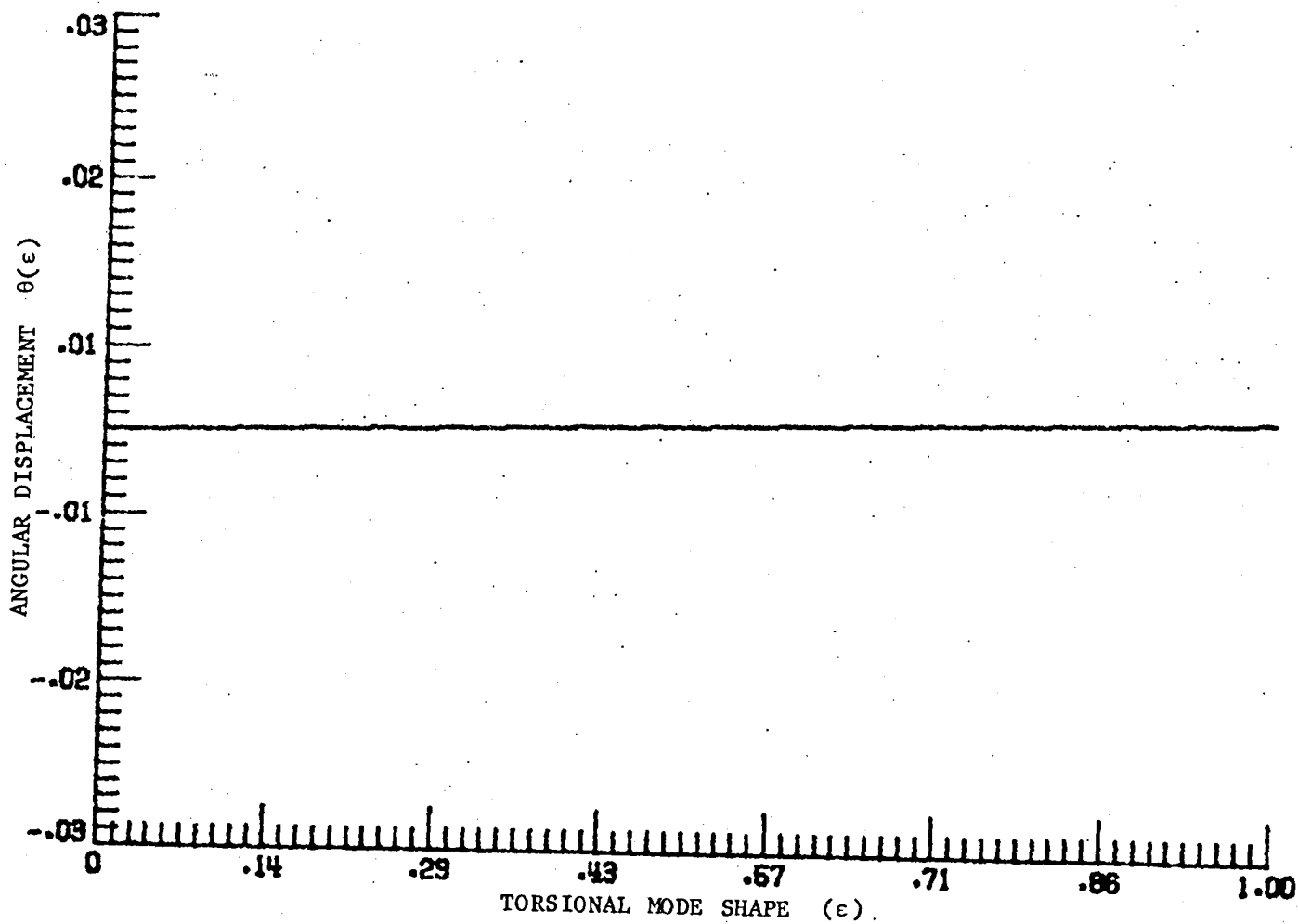

Figure B-5d: The torsional deflection of the fourth mode shape where θ (in rad.) is plotted versus the nondimensional position variable ϵ .

THE SOLUTION FOR MODE 5

THE FREQUENCY OF VIBRATION IS .2051804E+01 HZ.

THE XZ-PLANE MODE SHAPE IS

$$.9723593E-01 * \sin(\text{BETA1} * Z / L) + -.9063536E-01 * \cos(\text{BETA1} * Z / L) + \\ -.9739713E-01 * \sinh(\text{BETA1} * Z / L) + .9051900E-01 * \cosh(\text{BETA1} * Z / L)$$

THE YZ-PLANE MODE SHAPE IS

$$.5767110E-01 * \sin(\text{BETA1} * Z / L) + -.5459663E-01 * \cos(\text{BETA1} * Z / L) + \\ -.5839917E-01 * \sinh(\text{BETA1} * Z / L) + .5452724E-01 * \cosh(\text{BETA1} * Z / L)$$

THE TORSIONAL MODE SHAPE IS

$$-.4658896E-03 * \sin(\text{BETA2} * Z / L) + .3074803E-07 * \cos(\text{BETA2} * Z / L)$$

BETA1 = .3263103E+01

BETA2 = .2526313E+00

Figure B-6a: Natural Frequency and Mode Shapes calculated by BEAM3D for Mode #5.

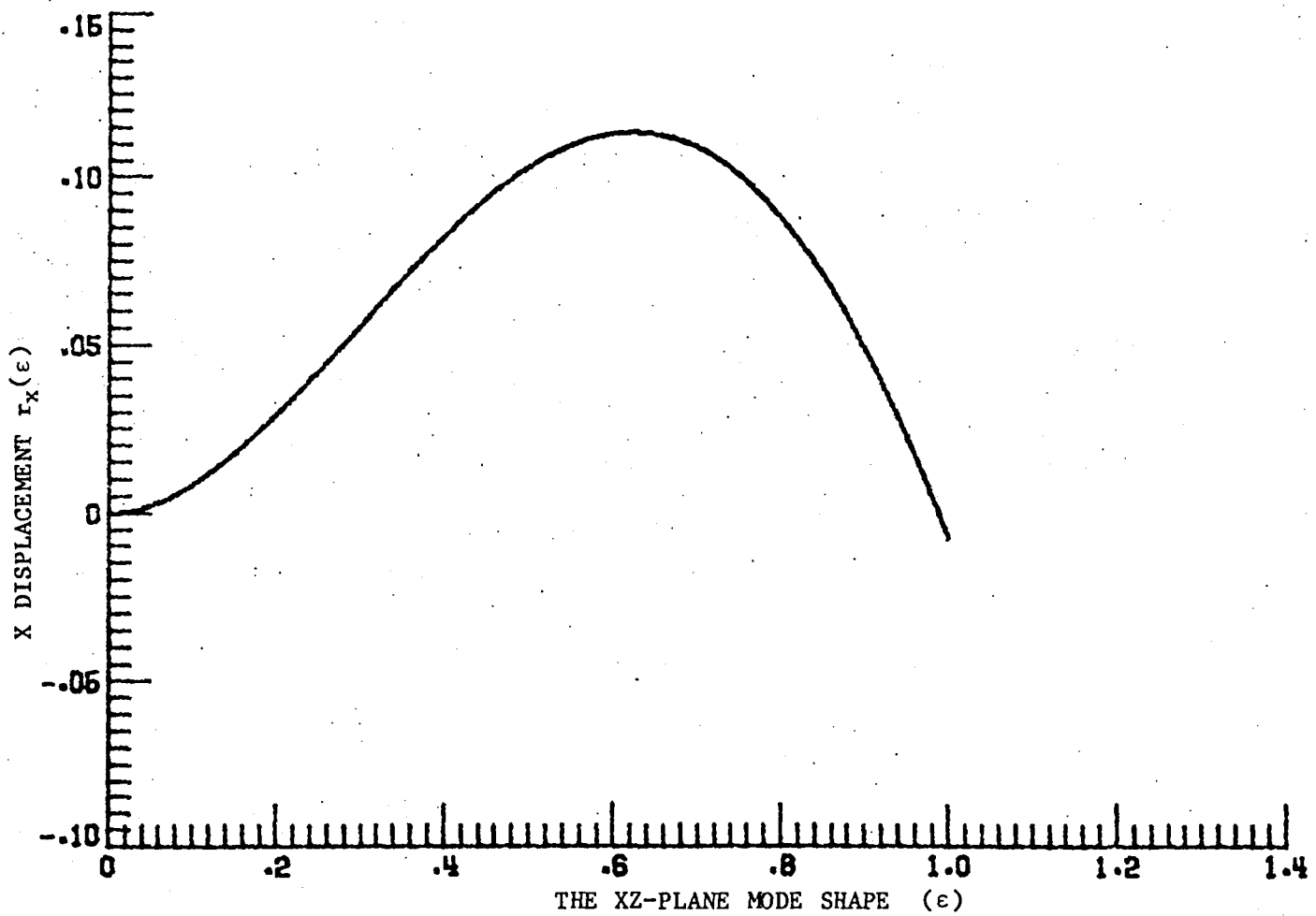

Figure B-6b: Projection of the fifth mode shape onto the xz-plane where the displacement r_x is plotted versus the nondimensional position variable ϵ .

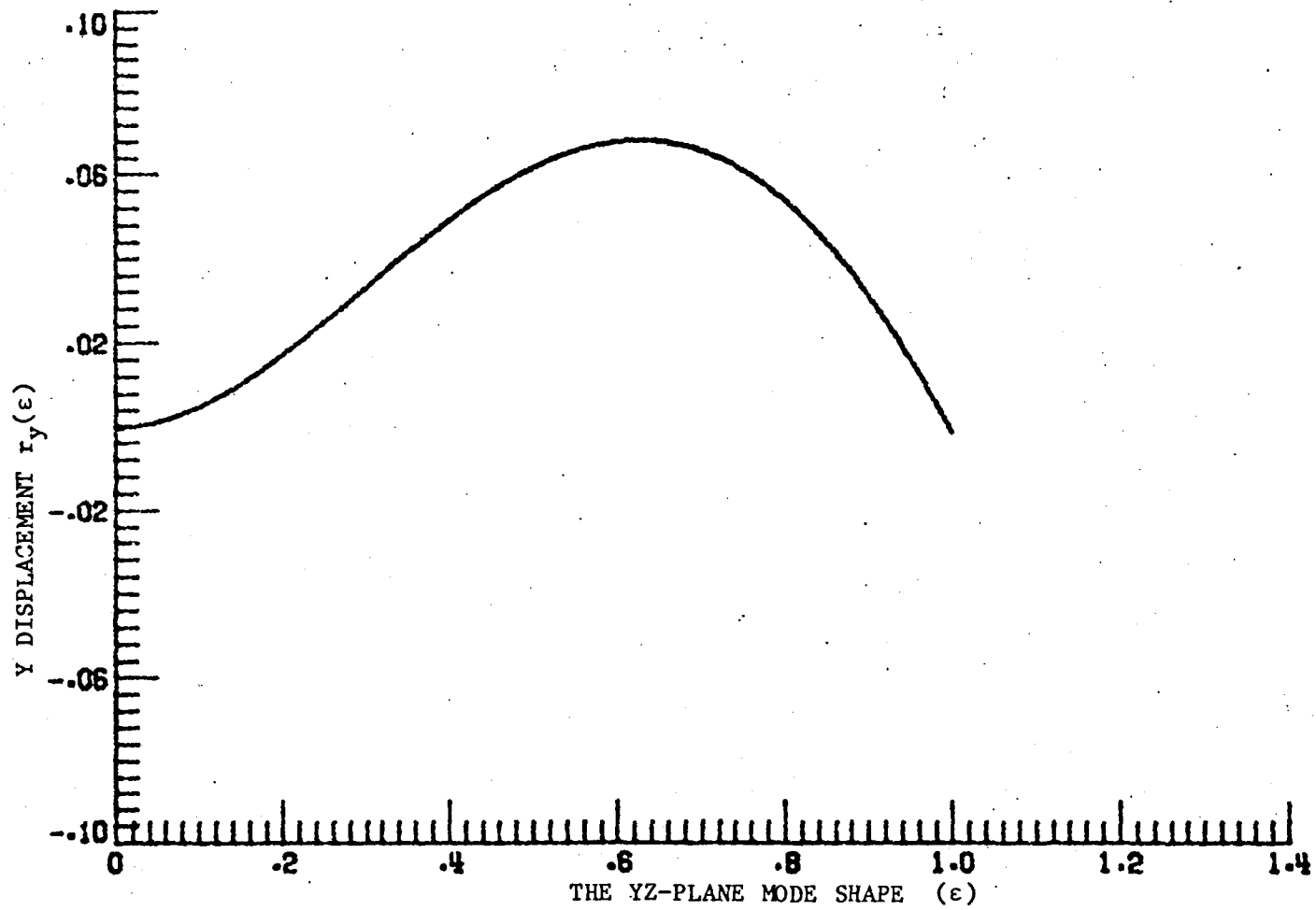

Figure B-6c: Projection of the fifth mode shape onto the yz-plane where the displacement r_y is plotted versus the nondimensional position variable ϵ .

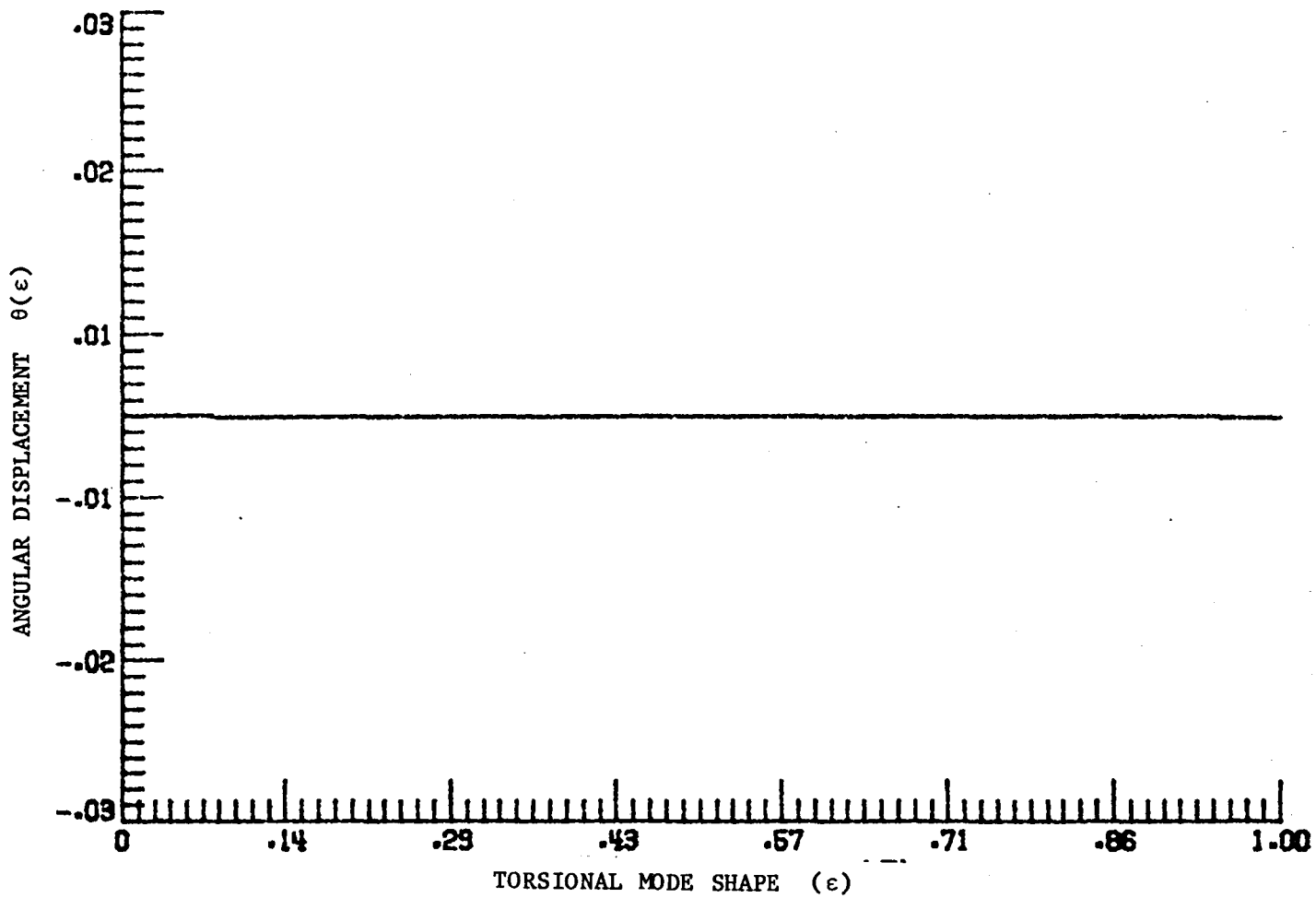

Figure B-6d: The torsional deflection of the fifth mode shape where θ (in rad.) is plotted versus the nondimensional position variable ϵ .

REFERENCES

1. Taylor, Lawrence W.; and Balakrishnan, A. V.: A Mathematical Problem and a Spacecraft Control Laboratory Experiment (SCOLE) Used to Evaluate Control Laws for Flexible Spacecraft. NASA/IEEE Design Challenge, June 1984.
2. Robertson, Daniel K.: Analysis of Lateral Torsional Vibration Characteristics of Beams and Shafts With End Located Rotational Masses. NASA TM-84593, May 1984.
3. Gorman, Daniel J.: Free Vibration Analysis of Beams and Shafts. John Wiley and Sons, Inc., 1975.
4. Landau, L. D.; and Lifshitz, E. M.: Theory of Elasticity, Second Edition. Pergamon Press, 1970.
5. Greenwood, Donald T.: Principles of Dynamics. Prentice Hall, Inc., 1965.

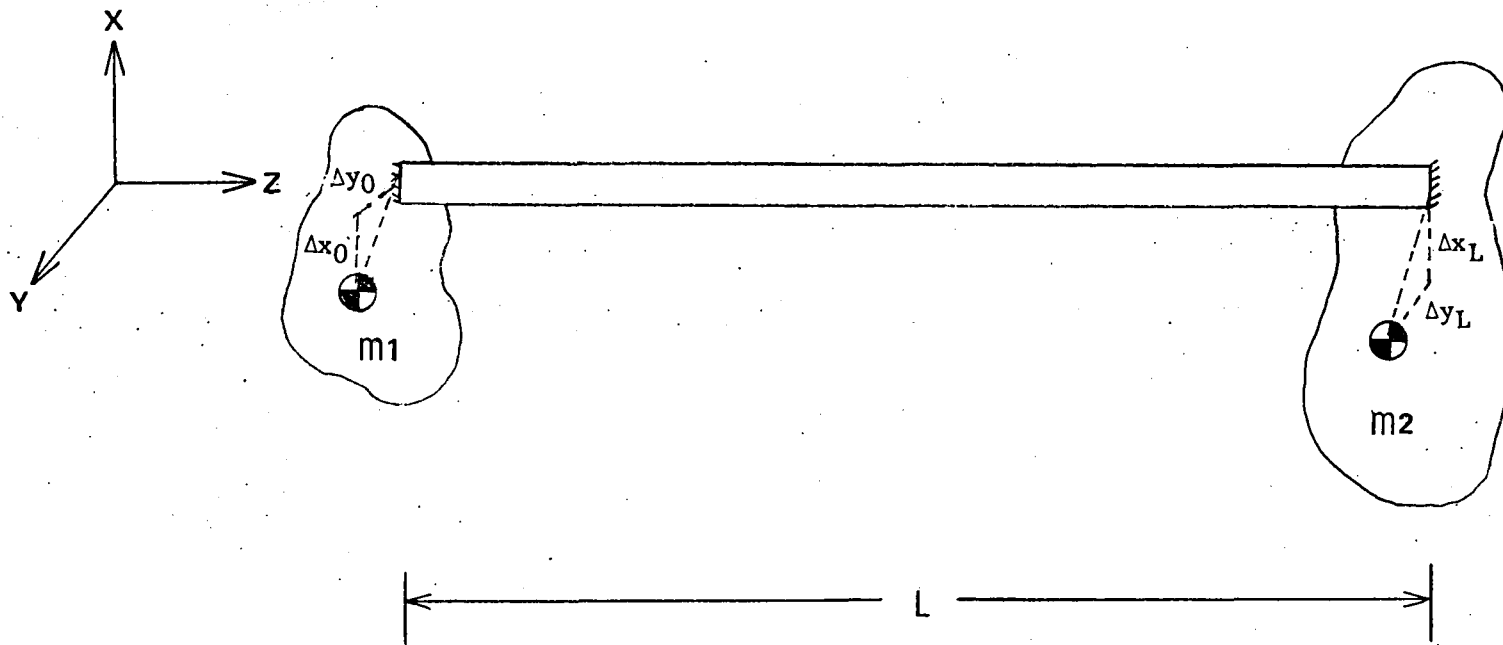

Figure 1: Beam with end-located inertial masses with x and y c.m. displacements

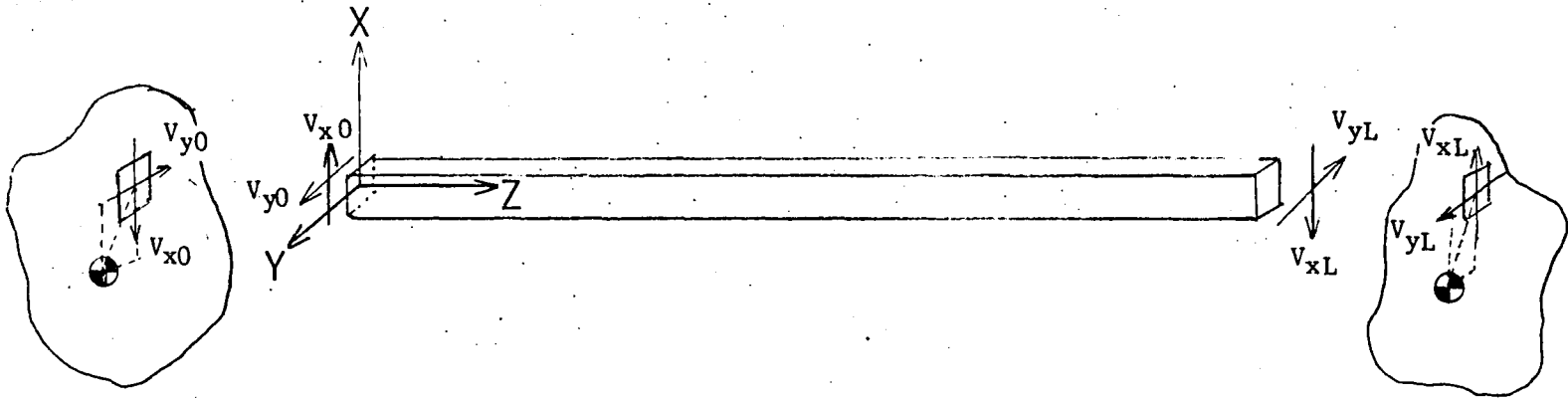

Figure 2: Anticipated shear reactions at both ends of the beam (z-forces are assumed negligible).

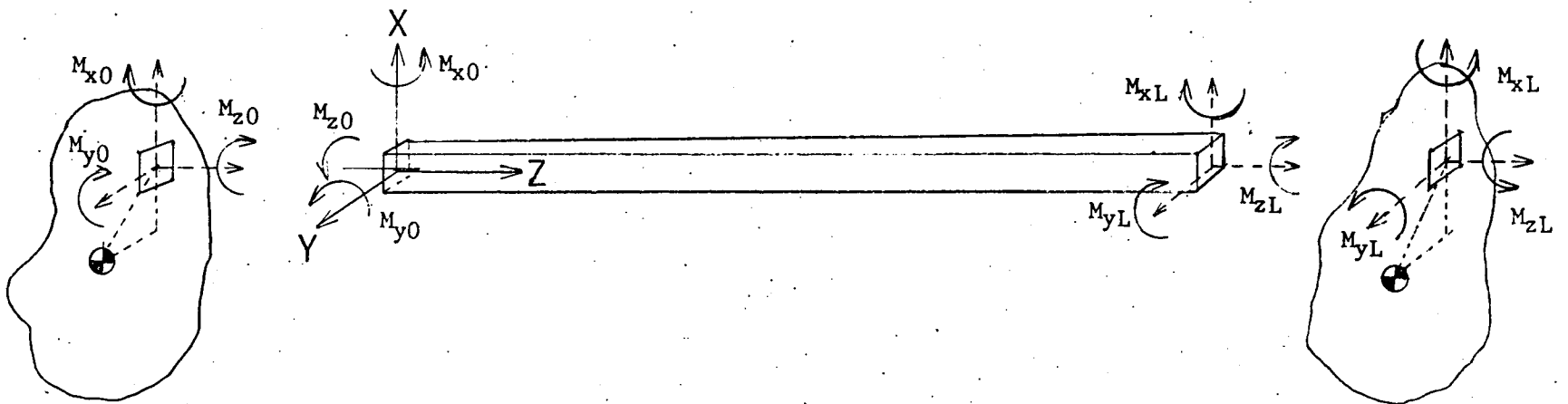

Figure 3: Anticipated moments at both ends of the beam

1. Report No. NASA TM-86393		2. Government Accession No.		3. Recipient's Catalog No.	
4. Title and Subtitle Three-Dimensional Vibration Analysis of a Uniform Beam with Offset Inertial Masses at the Ends				5. Report Date September 1985	
				6. Performing Organization Code 506-57-13-01	
7. Author(s) Daniel K. Robertson*				8. Performing Organization Report No.	
9. Performing Organization Name and Address NASA Langley Research Center Hampton, VA 23665				10. Work Unit No.	
				11. Contract or Grant No.	
				13. Type of Report and Period Covered Technical Memorandum	
12. Sponsoring Agency Name and Address National Aeronautics and Space Administration Washington, DC 20546				14. Sponsoring Agency Code	
15. Supplementary Notes *Cooperative engineering student from: University of Cincinnati, Cincinnati, OH.					
16. Abstract Analysis of a flexible beam with displaced end-located inertial masses is presented. The resulting three-dimensional mode shape is shown to consist of two one-plane bending modes and one torsional mode. These three components of the mode shapes are shown to be linear combinations of trigonometric and hyperbolic sine and cosine functions. Boundary conditions are derived to obtain nonlinear algebraic equations through kinematic coupling of the general solutions of the three governing partial differential equations. A method of solution which takes these boundary conditions into account is also presented. A computer program has been written to obtain unique solutions to the resulting nonlinear algebraic equations. This program, which calculates natural frequencies and three-dimensional mode shapes for any number of modes, is presented and discussed.					
17. Key Words (Suggested by Author(s)) Flexible beams Vibrating beams			18. Distribution Statement Unclassified--Unlimited Subject Category--39		
19. Security Classif. (of this report) Unclassified		20. Security Classif. (of this page) Unclassified		21. No. of Pages 70	22. Price A04

End of Document