Mission-Oriented Requirements for Updating MIL-H-8501 Calspan Proposed Structure and Rationale

Charles R. Chalk,
Robert C. Radford, Arvin/Calspan, Buffalo, N. Y.

Prepared for
Ames Research Center
Under Contract NAS2-11303
September 1985

NASA

National Aeronautics and
Space Administration

Ames Research Center
Moffett Field, California 94035

United States Army
Aviation Systems Command
Aviation Research and
Technology Activity
Moffett Field, California 94035



ABSTRACT

This report documents the effort by Arvin/Calspan Corporation to formulate a revision of MIL-H-8501A in terms of Mission-Oriented Flying Qualities Requirements for Military Rotorcraft. Emphasis is placed on development of a specification structure which will permit addressing Operational Missions and Flight Phases, Flight Regions, Classification of Required Operational Capability, Categorization of Flight Phases, and Levels of Flying Qualities. A number of definitions are established to permit addressing the rotorcraft state, flight envelopes, environments, and the conditions under which degraded flying qualities are permitted. Tentative requirements are drafted for Required Operational Capability Class I. Also included is a Background Information and Users Guide for the draft specification structure proposed for the MIL-H-8501A revision. The report also contains a discussion of critical data gaps and attempts to prioritize these data gaps and to suggest experiments that should be performed to generate data needed to support formulation of quantitative design criteria for the additional Operational capability Classes II, III, and IV.

PRECEDING PAGE BLANK NOT FILMED

FOREWORD

This report was prepared for the U.S. Government by Arvin Calspan Corporation, Buffalo, New York, in partial fulfillment of Contract NAS2-11303. The report describes the results of a study performed under contract with the National Aeronautics and Space Administration Ames Research Center, Moffett Field, California which was funded by the U.S. Army and the U.S. Navy.

The report documents the results of Phase I of a planned two phase study to develop mission oriented flying qualities requirements for military rotorcraft. The effort was directed by the Army Aviation Research and Development Command (AVRADCOM). Technical responsibility for the study was shared by the Aeromechanics Laboratory (AL) (Research and Technology Laboratories), Ames Research Center and the Directorate for Development and Qualification (D&Q) at St. Louis. The Naval Air Development Center (Warminster, Pa.) contributed to the program funding.

The program was monitored by Mr. Dean Carico and Mr. Chris Blanken of the Aeromechanics Laboratory (RTL). Overall direction and progress review was provided by a Government Technical committee which was co-chaired by Mr. David L. Key (Aeromechanics Lab. RTL) and Mr. William F. White, Jr. (AVRADCOM). The following individuals and organizations were members of the Technical Committee.

Mr. G. Heacock, AVRADCOM (DRDAV-DA)
Mr. C. Blanken, Aeromechanics Lab, RTL
Mr. J. Hayden, AEFA, Edwards AFB
LTC S. Ballard, ATZQ-D-M, Ft. Rucker
MAJ T. Edwards, DAMA-WSA, Wash., DC
Mr. C. Mazza, NADC, Warminster, PA
Mr. R. Nave, NADC, Warminster, PA
Mr. T. Lawrence, Nav Air Sys Comd
Mr. G. Smith, Nav Air Sys Comd
Mr. R. Bowes, NATC, Patuxent River
Dr. R. Chen, NASA-Ames
Mr. R. Gerdes, NASA-Ames
Mr. R. Woodcock, AFWAL-FIGC, WP AFB

Mr. J. Honaker, FAA, Ft. Worth
Mr. D. Simon/MAJ R. Tarr, ATL, Ft. Eustis
Dir., Structures Laboratory (RTL)

The program was performed by the Flight Research Department of the Research Division, Arvin Calspan Corporation. Mr. Charles R. Chalk was the Principal Investigator and Mr. Robert C. Radford was the Project Engineer.

Arvin Calspan Corporation was assisted in the Phase I study through subcontracted efforts by the following companies

Bell Helicopter, Ft. Worth, Tx.
Boeing Vertol, Philadelphia, Pa.
Sikorsky Aircraft Division, Stratford, Conn.
Dynasyst, Inc., Princeton, N.J.

This report documents the results of the Phase I effort by Arvin Calspan Corporation. The report content is tentative and has not been accepted or approved by the Government for official use.

TABLE OF CONTENTS

<u>Section</u>	<u>Title</u>	<u>Page</u>
1	INTRODUCTION	1
2	DEVELOPMENT OF A NEW SPECIFICATION STRUCTURE	2
3	INCORPORATION OF EXISTING CRITERIA AND DATA BASE	5
	3.1 FLYING QUALITIES REQUIREMENTS FOR OPERATIONAL CAPABILITY CLASS 1	5
	3.2 ENVIRONMENTAL CONDITIONS	5
	3.3 FLYING QUALITIES REQUIREMENTS FOR ADDITIONAL OPERATIONAL CAPABILITY CLASSES	6
	3.3.1 Discussion of Methods for Characterizing the Pilot-Rotorcraft Dynamic System	15
	3.3.2 Sources of Information and Data	40
4	CRITICAL GAPS	43
	4.1 IDENTIFICATION AND PRIORITIZATION OF CRITICAL GAPS	43
	4.2 REVIEW AND EVALUATION OF FACILITIES	64
	4.3 OUTLINE OF EXPERIMENTS TO GENERATE NEW DATA	74
	4.3.1 AGARD FMP Subcommittee 04	74
	4.3.2 Calspan Recommendations	75
	REFERENCES	82
APPENDIX A	DRAFT SPECIFICATION PROPOSED FOR MIL-H-8501A REVISION	A-1
APPENDIX B	BACKGROUND INFORMATION AND USERS GUIDE FOR DRAFT SPECIFICATION STRUCTURE PROPOSED FOR MIL-H-8501A REVISION	B-1
APPENDIX C	BIBLIOGRAPHY	C-1

LIST OF FIGURES

<u>Figure No.</u>	<u>Title</u>	<u>Page</u>
1	Candidate List of LHX Cockpit/Architecture Functions and Functional Requirements	10
2	Candidate List of LHX Cockpit/Architecture Functions and Functional Requirements - Flight Control	11
3	U.S. Army Lift Helicopter Criteria and Requirements	13
4	Neal-Smith Criterion Attitude Tracking Task	17
5	Closed Loop Performance Parameters	18
6	Proposed Criterion for Fighter Maneuvering Dynamics	19
7	Equivalent System Parameters	20
8	Mapping of Equivalent Systems on ω_n vs. η_z/α Plane	22
9	Bandwidth Criterion Definition of ω_{BW}	23
10	Bandwidth Criterion	24
11	Superaugmented Control Implementation	26
12	TIFS Pitch Rate Program-Effect of Command Washout on Rate Response	27
13	TIFS Pitch Rate Program-Effect of Command Washout on Rate Response	28
14	TIFS Pitch Rate Program - Configuration 4-3-7	30
15	TIFS Pitch Rate Program - Configuration 4-3-7-1	31
16	TIFS Pitch Rate Program - Configuration 8-3-5	32
17	TIFS Pitch Rate Program - Configuration 8-3-5-1	33
18	Illustration of Independence of Response to Control and Stabilization	35
19	Variation of Pilot Ratings with Changes in Generic Response to Control and Stabilization - IMC Bob-up Task	36
20	Tentative Association of Generic Response to Control and Stabilization with Flight Phase Categories and Task and Environmental Factors	37

LIST OF FIGURES (Cont.)

<u>Figure No.</u>	<u>Title</u>	<u>Page</u>
21	Examples of Anomolous Pilot Ratings for RA/LV SCAS Configurations	38
22	Illustration of Inputs Required for Determination of Response to Control and Stabilization with ADOCS Model following Control Implementation	41
23	CFPD Vertical Situation Display	48
24	Approach HUD Format Used in NT-33A	49
25	Block Diagram of Rotor Speed Governing System using Rotor Collective Pitch	54
26	Rotor Thrust and Speed Response to Collective Command - No Collective Pitch Feedforward	55
27	Rotor Thrust Speed Response to Collective Command - Collective Pitch Feedforward Command Equal to 67% of "Ideal" Gain	56
28	Rotor Thrust and Speed Response to Collective Pitch Command - Collective Feedforward Gain Equal to 133% of "Ideal" Gain	57
29	Rotor Thrust and Speed Response to Collective Command - Collective Feedforward Gain Equal to "Ideal" Gain	58
30	Longitudinal Flapping Frequency Responses to Longitudinal Gust and Lateral Gradient of Vertical Gust	63
31	Comparison of McLATHOS and LATHOS Baseline Configurations	67
32	The Vertical Motion Simulator (VMS) RSIS Project Overview	70
33	Q Response To B_{15} Step (CH-53, 100 KT)	72
34	P Response To B_{15} Step (CH-53, 100 KT)	73

Section 1 INTRODUCTION

The official government specifications for helicopter handling qualities is MIL-H-8501A. This document was initially adopted by the U.S. Army and Navy in 1952, and has not been updated since 1961. Study efforts by Kidwell in 1968 and by Green and Richards in 1973 (Ref. 2) proposed revision to MIL-H-8501A but they were never officially adopted by the Government. For major procurements such as the Advanced Attack Helicopter (AAH) and the Utility Tactical Transport Aircraft System (UTTAS), the Army has developed Ad Hoc specifications termed Prime Item Development Specifications (PIDS) and has not directly applied MIL-H-8501A.

In 1982, The Army Aviation Research and Development Command initiated a two-phase contracted program to develop mission-oriented handling qualities requirements for Military rotorcraft. Contracts for Phase I of the program were awarded to Arvin Calspan Corporation and to Systems Technology, Inc. Following completion of the Phase I efforts, one of the two contractors will be selected to perform the Phase II contracted effort.

The Phase I study had three principal objectives

- Develop a New Specification Format
- Incorporate Existing Criteria and Data Base
- Definition of Critical Gaps

This report documents the results produced by Calspan under the Phase I study effort.

Section 2
DEVELOPMENT OF A NEW SPECIFICATION STRUCTURE

A primary objective of the Phase I study was to develop a specification structure that would permit systematic treatment of significant factors such as the following:

- Rotorcraft types and roles
- Flight Phases
- Flight at hover and flight at high forward speed
- Mission requirements for capability to operate at night or in adverse weather.
- Recognition of varied tasks to be performed.
- Treatment of environmental conditions
- Rotorcraft configuration and loading
- Rotorcraft failure states
- Levels of flying qualities
- Controllers
- Information displays
- Vision aids
- Stability and control augmentation

The specification structure evolved by Calspan during the Phase I study is contained in Appendix A of this report. The philosophy and reasoning which led to

this specification structure is discussed in Appendix B which is the start of a "Background Information and Users Guide" for the new mission-oriented flying qualities specification for military rotorcraft.

The specification structure was developed by Calspan through an interactive process which included review of existing specification documents, consultation with government and industry personnel followed by preparation of a series of draft documents which were reviewed by government and industry engineers. References 2-9 were reviewed and consultations were held with members of the Government Technical Committee (see Foreward), with engineers at helicopter manufacturing companies, and with Mr. Theodore Dukes of Dynasyst, Inc. The organizations which Calspan visited for consultation during the Phase I study are listed below. The asterisk identifies subcontractors

*Bell Helicopter	Aeromechanics Laboratory
*Boeing Vertol	AVRADCOM St. Louis
*Sikorsky Aircraft	NASC Washington, D.C.
*Dynasyst	NADC Patuxent River
FAA Southwest Region	NATC Patuxent River
Ft. Rucker	NTFS Patuxent River
Army Aviation Test Activity	HM-12, 14, 16 MCM Squadrons

With this background, Calspan drafted tentative versions of the specification structure which were distributed to members of the Technical Committee and to the Subcontractors for review. In March 1983, a tentative specification structure was presented to the Technical Committee members during the interim program review meeting which was held at Ames Research Center. Review comments from the government and industry sources (which included design, test, research, procurement, certification and training disciplines) contributed to the evolution of the specification structure presented in Appendix A.

The structure proposed for the mission-oriented flying qualities specification for military rotorcraft is broadly similar to the structures of MIL-F-8785C and MIL-F-8330, however, there are significant differences in the classifications, categorizations and definitions which will better facilitate achieving the goal of developing mission-oriented flying qualities requirements.

The specification structure requires that the operational missions for which the rotorcraft is to be designed must be divided into segments which are identified as Flight Phases. Each Flight Phase is assigned to one of eight Flight Phase Categories on the basis of required maneuver capability, precision of space position control and whether or not target tracking is required. The Flight phases are also assigned to Operational Capability Classes on the basis of the visual conditions under which the Flight phase is required to be performed and the number of crew members. In addition, the Flight Phases are assigned to Flight Regions on the basis of speed, acceleration, power and ground contact.

Initially, the flying qualities requirements will be separately stated for each of the Operational Capability Classes. After the entire specification document has been drafted, the requirements for each Operational Capability Class will be reviewed to determine whether the separate sets of requirements can be combined to reduce the volume of the specification document. Within each Operational Capability Class, the requirements are separately stated for each Flight region. The Levels concept is used in the requirement statements and the individual requirements are applied to Flight Phase Categories or groups of Flight Phase Categories as appropriate for each requirement.

There are no classification categories based on mission, size, weight or configuration factors. It is believed that the flying qualities requirements should be independent of configuration factors and that the adopted structure permits adequate accommodation of size, weight and mission factors.

Definitions of Rotorcraft States are introduced along with definitions of Flight Envelopes and Operating Environments. The combinations of these factors for which degraded flying qualities will be permitted are defined in the specification structure.

In Appendix B, each element of the specification structure is introduced, amplified and discussed.

Section 3
INCORPORATION OF EXISTING CRITERIA AND DATA BASE

3.1 FLYING QUALITIES REQUIREMENTS FOR OPERATIONAL CAPABILITY CLASS I

The existing data base and the criteria in Refs. 4-6 are considered to apply primarily to only one of four Operational Capability Classes defined in the specification structure of Appendix A. Flying qualities requirements for Operational Capability Class I were drafted by Calspan using the terminology defined in Sections 1 and 2 of Appendix A. These requirements are presented in Section 3 of Appendix A.

The requirements are drawn primarily from the Prime Item Development Specifications (PIDS) for the UTTAS, AAH and AHIP Programs. Other sources were MIL-H-8501A, MIL-F-83300 and the technical literature. An attempt was made to remedy a number of objectional characteristics of the format of the PIDS documents. It is very difficult to find specific requirements in the PIDS documents because the paragraphs are not titled and many requirements are buried within single paragraphs. In addition, the requirement statements of different paragraphs are repetitious in the wording of conditions. When drafting the requirements in Section 3 of Appendix A, Calspan applied the following guidelines. Each requirement paragraph is numbered and titled, each paragraph states a single type of requirement, and the volume of the specification has been minimized by wording certain paragraphs so that similar requirements for several axes are stated in a single paragraph with appropriate numbers for each axis listed in Tables.

3.2 ENVIRONMENTAL CONDITIONS

In the proposed structure, the procuring activity is charged with responsibility for defining the environmental conditions to be used by the contractor to design and evaluate the rotorcraft. Consideration of the environment is incorporated in the specification structure in a manner that is intended to permit the procuring activity to specifically define environmental conditions for each procurement. This approach permits tailoring the design environmental conditions to be consistent with the intended operational missions of the rotorcraft. In Section 3.9 of the proposed specification, Calspan has defined models of various environmental components which may be used

at the discretion of the procuring activity. The wording used in Section 3.9 is such that the environment models defined by Calspan must be used by the contractor if the procuring activity does not otherwise define the environments for a specific procurement. The environment models defined by Calspan are presented in Section 3.9 of Appendix A.

3.3 FLYING QUALITIES REQUIREMENTS FOR ADDITIONAL OPERATIONAL CAPABILITY CLASSES

The structure of the specification permits stating requirements separately for each of several Operational Capability Classes. Calspan has drafted requirements for Class I and the intent is to separately draft requirements for each of the other Classes. These requirements will then be coalesced where possible to reduce the volume of the specification document.

Operational Capability Class II applies to situations where the pilot cannot obtain position and velocity cues from the external view with his unaided eyes. This Classification applies to Flight phases such as mine sweeping, sea search or navigation above a cloud layer. In these situations, equipment (avionic) is required to determine position and direction of flight and horizontal situation displays or flight director displays are required for the pilot. Stability and control augmentation requirements for search and navigation Flight Phases are not expected to be increased beyond what is necessary for Class I but the dynamic requirements for mine countermeasures may be considerably increased because of the complexity of the Task. The pilot must control the rotorcraft to stay within many task constraints such as boom angle, cable tension, sled speed relative to the water and sled track. To accomplish this, the rotorcraft may have to fly at unusual attitudes, crab angles, slideslip angles, airspeed and power settings. The workload can be quite high unless information displays and augmentation are provided.

Operational Capability Class III applies to situations where the pilot cannot obtain horizontal and vertical orientation cues from the external view with his unaided eyes. This Classification applies to Flight Phases requiring flight near obstacles in poor visibility such as shipboard landing with reduced visibility and high sea state where there is no horizon visible and the ocean surface and ship deck are in constant motion. In this situation, equipment to measure rotorcraft angular orientation and rotational rates may be required for use in vertical situation displays and stability augmentation systems. Integrated electronic head-up displays or helmet mounted displays may be

required for certain Flight Phases. Increased rate damping and attitude stabilization may be required for Level 1 flying qualities. Command-hold modes of the flight control system may be necessary for Level 1 flying qualities in single pilot situations.

Operational Capability Class IV applies to situations where the pilot cannot obtain any information from the external view with his unaided eye. This classification applies to Flight Phases that must be performed in fog, darkness, cloud or with windows shuttered for protection from extreme light flashes or laser beams. In this situation, equipment is required to sense angular orientation, horizontal and vertical position, rates and accelerations for horizontal and vertical situation displays and for stability and control augmentation. Flight near obstacles may require vision aids. Command-hold modes and automatic coupled-guidance-flight-control modes may be necessary for Level 1 flying qualities. Single pilot operation may require automated functions with the pilot serving as system manager and monitor of performance. The Army LHX program is an example of Class IVs.

Flight Phases that belong in Class IV or IVs range from point to point navigation in cloud to blind terrain following, nap of the earth flight at night and blind landing on a small ship in high sea state. The sensors, computers, displays, vision aids, flight control modes and the degree of automation of functions required to maintain an acceptable work load in operational capability Class IV or IVs is a strong function of the operational mission, the particular flight phase, the operating environment and the exposure to enemy threats. Navigation in clouds can be accomplished with only an automatic direction finder (ADF) or with an ADF and a directional gyro (DG) but blind terrain following will require considerably more equipment such as specialized radar, computers, displays and directors or an automatic flight control system coupled to the terrain following radar and command computer.

Operational Capability Class IV can involve complex tasks which may be accomplished by a variety of design solutions and equipment configurations. A firm guideline for preparing specifications is that the military specifications must not inhibit viable design solutions or become locked to any stage of technology development. This guideline discourages writing specification requirements which dictate any particular flight control system concept or configuration. The challenge is to find a way to specify desirable flying qualities and to prohibit intolerable flying qualities degradations without dictating the system design, but, at the same time to provide design guidance.

One approach for accomplishing these goals is to hypothesize several feasible flight control concepts and to write specifications limiting the range of dynamic parameters for each concept. The designer would be allowed the freedom to select the concept to be used in a particular program based on the complexity of auxiliary tasks, the number of crewmen and the degree to which information displays and vision aids are to be included in the overall design.

The Army LHX program is being conceived as an application of advanced technology for control, sensors, information processing, displays, vision aids, communications, navigation and weapons. Figures 1 and 2 list LHX Functions and Flight Control features under consideration. The technology available will permit design of the LHX rotorcraft so as to optimize: the response to pilot commands, stabilization relative to desired references, rejection of external disturbances, and suppression of undesired coupling. Response to pilot commands can be tailored through feedforward design whereas stabilization and disturbance rejection design can be tailored through feedback control methods. Suppression of undesirable coupling can be accomplished by using both feedforward and feedback techniques. Specification requirements could be written for a number of control concepts which have been shown through research and experience to be capable of providing good flying qualities and for stabilization concepts that have been shown to improve task capability and accuracy. Under this approach, the LHX designer would be left the freedom to select the particular flight control system concept that best complements his overall system design objectives.

An alternate approach for specifying flying qualities objectives and performance goals will be considered for specific flight phases which involve complex tasks. In this approach, task performance goals are stated along with limiting values of pilot ratings for the augmented system and for failure modes. This approach was successfully used during the U.S. Army Heavy Lift Helicopter (HLH) program. The criteria and requirements used for the HLH program are summarized in Figure 3. In response to this specification, the contractor performed analysis, simulation and prototype flight tests in the process of developing the HLH vehicle design. Although the actual HLH was not built or evaluated in the operational mission and environment, a prototype testbed was built and flight evaluation indicated the design was successful.

Calspan proposes to pursue development of both of the approaches outlined above during Phase II of the program to develop mission oriented flying qualities for military

rotorcraft. Regardless of which approach is chosen for stating the requirements in the specification document available data will be reviewed, studied and utilized to tentatively define the dynamic characteristics of promising flight control concepts. This information will be documented in the background information and users guide.

During the IPR-2 meeting in St. Louis, Systems Technology Inc. representatives presented a classification scheme which embodied the hypothesis that increased Flight Control augmentation could be traded for lack of outside visual cues. It is Calspan's opinion that this hypothesis is not generally valid. In particular, the hypothesis is not valid for Flight Phases requiring maneuvering flight, at other than very low speed, near obstacles. The speed at which NOE flight can be performed will be limited by the visual cues available regardless of how highly the flight control system is augmented. A primary factor limiting the speed will be the visual range available which will limit the time available to generate and execute obstacle avoidance maneuvers. This situation is analogous to driving an automobile in fog. Improving the steering response will not be very effective in increasing the maximum safe speed when the fog limits visual range to say 50 feet. In situations such as these, improvements in task performance capability can be realized through use of vision aids but cannot be achieved through increased control system augmentation without the vision aids. The hypothesized trade of increased augmentation for degraded visual cues is, therefore, not generally valid.

Figure 1

**CANDIDATE LIST OF LHX COCKPIT/ARCHITECTURE FUNCTIONS
AND FUNCTIONAL REQUIREMENTS**

<u>LHX Functions</u>	<u>Avionics Functions Required</u>
Reconnaissance	Navigation - absolute Flight control Target acquisition Data management Communication
Command Attack Team	Navigation - relative Data management Communication
Target Acquisition and Attack	Navigation - absolute and relative Flight control Target detection, track, and classification Fire control calculations Weapons management
Target Acquisition and Hand-off	Navigation - absolute Flight control Target detection, track, and classification Data management Communication
Threat Detection and Countermeasures	Threat detection and identification Countermeasures management Data management Communication
Suppress Enemy Air Defense	Target detection, track, and classification Navigation - relative Flight control Fire control calculations Weapon management
Adjust Indirect Fire	Target detection, track, and classification Indirect fire impact point estimation Data management Communication Navigation - absolute Flight control
Attack Targets of Opportunity	Target detection, track, and classification Navigation - relative Flight control Fire control calculations Weapon management

Figure 2

CANDIDATE LIST OF LHX COCKPIT/ARCHITECTURE FUNCTIONS
AND FUNCTIONAL REQUIREMENTS - FLIGHT CONTROL

Flight Control

Features:

- Automatic flight path control to the degree required to allow the pilot to perform the critical tasks.
- The NOE flying qualities provided by the primary flight control system shall be consistent with survival in the hostile air defense environment.
- Extremely dependable primary stabilization system
- Considerable automatic mode switching without significant transients
- Highly coupled modes with navigation and target acquisition subsystems.

Modes (Goals):

- Primary stability
- Contour flight modes
 - Heading, mixed baro/radar altitude, airspeed hold
 - True course, mixed baro/radar altitude, airspeed hold
- Transition/letdown - climbout modes
 - Deceleration transition by vertical velocity; airspeed reduction contour controlled as dependent variable
 - Computed flightpath letdown to low hover
 - Computed flightpath climbout to contour flight condition
 - Deceleration letdown on landing guidance path
 - Climbout on guidance path
- Hover modes
 - Normal hover - heading, radar altitude, zero ground-speed hold, including controlled bobup and down
 - Weapon delivery hover - pitch and roll stabilized, heading driven by fire control computer

- NOE modes
 - Heading, radar altitude, groundspeed hold with airspeed limits
 - True course, radar altitude, groundspeed hold with airspeed limits
 - Waypoint steering, radar altitude, groundspeed hold with airspeed limits
 - NOE weapon delivery
- Automatic Return to Cover - Flight path from marked point will be memorized and aircraft will fly at maximum performance back to the marked point when given appropriate command.

Figure 3

U.S. ARMY HEAVY LIFT HELICOPTER CRITERIA AND REQUIREMENTS

Comprehensive criteria were established for design of the HLH Automatic Flight Control System early in the ATC Program. The original ATC Statement of Work contained a set of "design objectives" for the AFCS, and the Prime Item Description Document (PIDD), delineated both objectives and requirements. The SOW design objectives are divided roughly into two groups with about half pertaining to handling qualities improvement and the remainder to specific "performance" type goals for the augmented aircraft. Handling qualities objectives include:

- Simplification of the piloting task.
- Optimization of vehicle handling qualities.
- Minimization of pilot switching modes of operation between flight regimes, and elimination of transients introduced as a result of mode switching or transfer of control between pilots.

Performance-oriented goals for the augmented aircraft are somewhat more specific in nature as indicated by requirements to provide:

- Capability for the pilot to position the helicopter and/or load (without visual ground reference) to a prescribed heading, at any height above the terrain up to 100 feet, and within 4 inches of a ground reference point. The design should permit accomplishment of the positioning task within 2 minutes, starting from a point 200 feet above ground level and 300 feet horizontally from the reference point, under gusty wind conditions, with steady winds of up to 45 knots from any azimuth.
- Capability for hands-off hovering (with or without suspended load) within +4 inches vertically, +4 inches horizontally, and within 2 degrees of a given heading, under the wind conditions prescribed above.
- Capability for automatic positioning of the helicopter vertically over a load once cables are attached and under tension.
- Capability for automatic load stabilization to eliminate dangerously unstable moments, thereby permitting the helicopter to be flown in IFR conditions without stabilization inputs by the pilot.

Requirements defined in the PIDD, Volume I, relate handling qualities to mission accomplishment. This document states that the HLH flying and ground handling maneuverability and stability, with or without external payload, at all usable weights, CGs, airspeeds, and altitudes within the normal flight envelope, "shall be adequate to perform the design mission(s) in both IFR or VFR flight conditions". Included in the normal flight envelope are airspeeds to 45 knots in any direction starting from hover in still air.

The PIDD also stipulates that the MIL-H-8501A specification, with approved Army deviations for autorotational descent and landing, should be adhered to in

determining aircraft handling qualities for both augmented and unaugmented flight or ground operation.

In addition to the PIDD Volume I requirements mentioned above, PIDD Volume II lists additional "stability and control" objectives for use as guidelines in design and verification of the AFCS. These relate to subjective pilot evaluations of handling qualities through use of the Cooper-Harper rating system. For the augmented vehicle (with AFCS operating normally) ratings of 2.0 or better are desired. With the neutrally stable unaugmented aircraft, ratings of no worse than 5.0 are desired. Cooper-Harper rating techniques were utilized extensively throughout the various piloted AFCS simulations and flight demonstrations to gauge progress in developing the superior handling qualities required for the HLH mission.

3.3.1 Characterization of Pilot/Rotorcraft Dynamic Systems

During the last decade, the fixed wing community has devoted considerable effort to developing flying qualities and flight control design criteria for conventional aircraft. These efforts have been motivated, in part, by the introduction of fly-by-wire flight control systems using powerful digital computers. Aircraft with such systems typically exhibit dynamics of considerably higher order than an unaugmented vehicle. As a result, flight control design criteria which are expressed in terms of engineering parameters such as individual stability and control derivatives or the modal parameters of a "classical" six degree of freedom aircraft dynamic model are either unapplicable or at least difficult to interpret for these modern control systems. Furthermore, digital logic has also facilitated the use of non-linear system elements such as mode switching and gain tailoring to optimize stability and control and flying qualities. As a consequence of these developments, much of the criteria development effort has been focussed on methods which are independent of the order and, in some cases, the linearity of the aircraft and flight control system. Since typical rotorcraft, even without augmentation systems, will exhibit both higher order and non-linear dynamics, it is logical to make maximum use of fixed wing criteria development efforts.

A survey of such criteria was made in order to identify promising methods and to assess their applicability and shortcomings for rotorcraft application. In general, the criteria are input-output oriented in that the flying qualities are characterized in terms of state responses to specific control inputs. Both time domain and frequency domain measures have been developed and each has specific advantages for rotorcraft. Time domain criteria are attractive because the system dynamics can be characterized in terms of parameters which can be readily measured from either flight test or analytically generated time histories. Further, time domain criteria can be applied to both linear and non-linear systems, an attribute which is particularly attractive for rotorcraft. A potential disadvantage is that certain dynamic modes which may have small residues in the response to idealized step and doublet control commands may exhibit large and potentially troublesome response to periodic type inputs. In this respect frequency domain criteria methods can be advantageous.

In the following paragraphs, several of the more well known longitudinal dynamics criteria for fixed wing aircraft will be described and discussed. The point of the discussion is not to debate or argue the merits of each criteria or their relative

superiority but rather to highlight the assumptions implicit in their use and to assess their potential applicability to rotorcraft.

An example of a widely used criterion for longitudinal dynamics is Neal-Smith (Reference 15). This criterion was developed in the course of analyzing the results of an in-flight experiment to investigate the effects of higher order dynamics on up-and-away fighter maneuvering tasks. The criterion assumes that the essence of the fighter tracking task is attitude control in a compensatory tracking sense as illustrated in Figure 4. Application of the criterion involves adjusting the parameters of a "pilot" model (comprised of lead, lag, delay and gain elements) to achieve a desired closed loop bandwidth while minimizing resonance and mid or low frequency droop. The desired closed loop characteristics are illustrated in Figure 5. The flying qualities characteristics for attitude tracking can then be inferred from the closed loop resonance magnitude and the pilot model lead or lag compensation as shown in Figure 6.

This criterion has been applied in a variety of aircraft development and experiment correlations with considerable success. One of its primary attractions is that it attempts to treat both the performance (closed loop bandwidth, resonance and droop) and workload (lead/lag compensation) in an integrated fashion. Application of the criterion requires the a priori specification of bandwidth which is, in effect, a measure of the aggressiveness required in the attitude control task. Early attempts to apply the criterion to landing approach tasks were unsuccessful because it was mistakenly assumed that compared to fighter tracking, the landing task was low bandwidth.

A recent criterion method, which attempts to apply existing classical model criteria to systems with higher order dynamics is the equivalent systems technique. This method is included both in the flying qualities specification MIL-F-8785C and in the proposed MIL standard for MIL-F-8785C. As illustrated in Figure 7, the method involves the determination, over a specified frequency range, of a lower order "best fit" or equivalent model of the higher order system. The lower order model also includes an equivalent time delay term to account for additional phase shift associated with the higher order flight control system.

The flying qualities of the higher order system can then be determined from existing criteria for short period frequency (ω_E) and $n_z/\alpha = V/g (1/T_E)$ together with

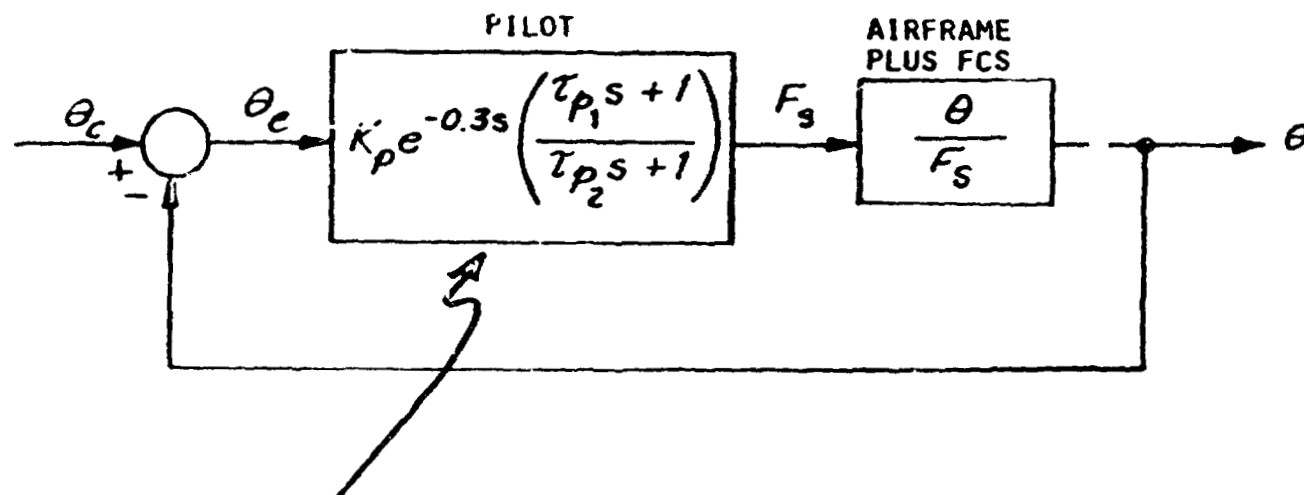

PITCH ATTITUDE COMPENSATOR (LIKE PILOT)

Figure 4. NEAL-SMITH CRITERION ATTITUDE TRACKING TASK

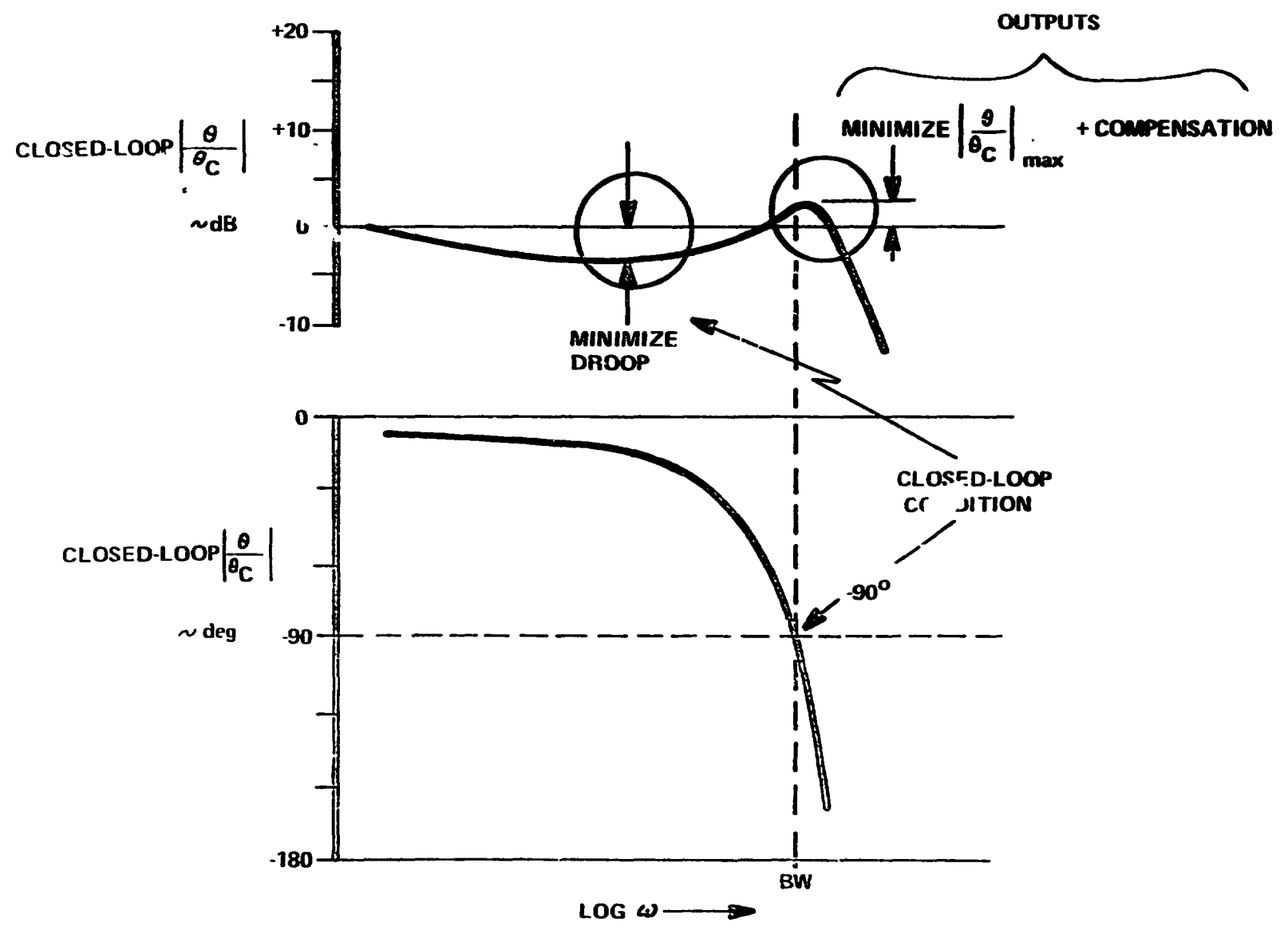

Figure 5. CLOSED LOOP PERFORMANCE PARAMETERS

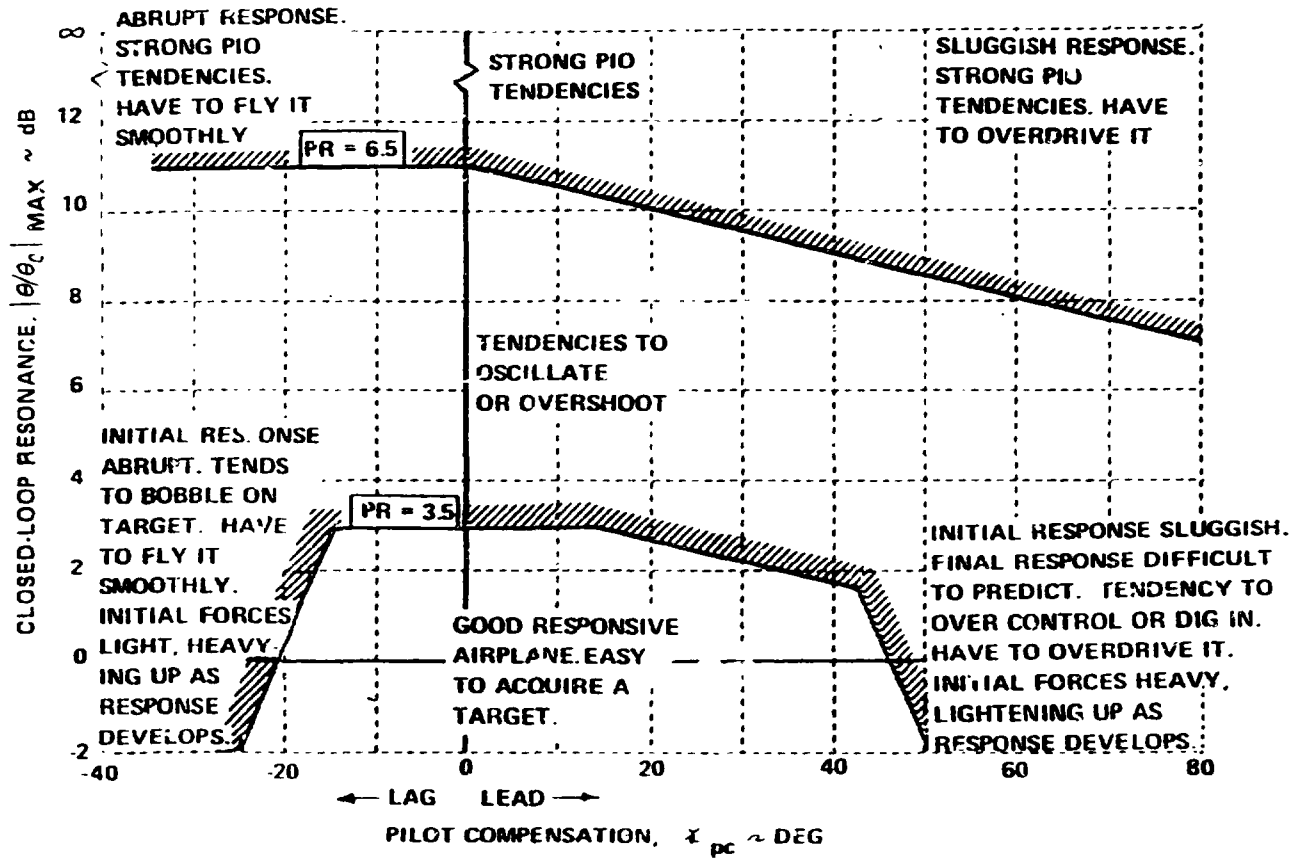

Figure 6. PROPOSED CRITERION FOR FIGHTER MANEUVERING DYNAMICS

MIL-F-8785C (NOV 80)

- USES LOW ORDER EQUIVALENT SYSTEM OF HIGH ORDER RESPONSE TO RELATE TO CLASSIC SPECS OF 8785B

$$\frac{\dot{\theta}(s)}{F_S(s)} = \frac{K e^{-A_E s} (s + 1/T_E)}{s^2 + 2 \zeta_E \omega_E s + \omega_E^2}$$

20

- ADDS TABLE FOR ALLOWABLE EQUIVALENT TIME DELAY

Table XIV
ALLOWABLE AIRPLANE RESPONSE DELAY

LEVEL	ALLOWABLE DELAY SEC
1	0.10
2	0.20
3	0.25

Figure 7. EQUIVALENT SYSTEM PARAMETERS

additional limits imposed on allowable equivalent time delay. There are still many unresolved issues with respect to this criterion among which are:

- the uniqueness of the equivalent system model
- the frequency range over which the equivalent model must be determined
- how to interpret a large mismatch between the high order and equivalent system
- whether $1/T_E$ must be fixed at its actual value or should be calculated for a best fit

With respect to the last point, Figure 8 illustrates the variation of the location of the lower order model in the ω_n versus n_z/α parameter plane depending on whether $1/T_E$ is fixed or allowed to float.

The bandwidth method is another frequency domain criterion which has been included in the proposed MIL Standard for MIL-F-8785C. In contrast to Neal-Smith, which requires a priori knowledge of bandwidth, this method is based on the notion that the higher the bandwidth, the better the flying qualities. Application of the criterion requires the determination of the attitude response bandwidth (defined in terms of gain or phase margin) and a phase delay as defined in Figure 9. The level of flying qualities can then be inferred from bounds on the bandwidth frequency and the phase delay parameter as shown in Figure 10.

Although each of these criteria methods differ in details, they are all similar in the sense that they assume that pitch attitude regulation is the dominant longitudinal control task. Furthermore, the criteria tend to exclude both high frequency and low frequency response characteristics from consideration because they are all based on the attitude response dynamics over a limited frequency range in the neighborhood of crossover or bandwidth frequency.

Certain of the results from a recent TIFS flight experiment (Reference 16) indicate that at least for the flare and touchdown phase of the landing approach, significant changes in flying qualities can be realized by modifying either the low

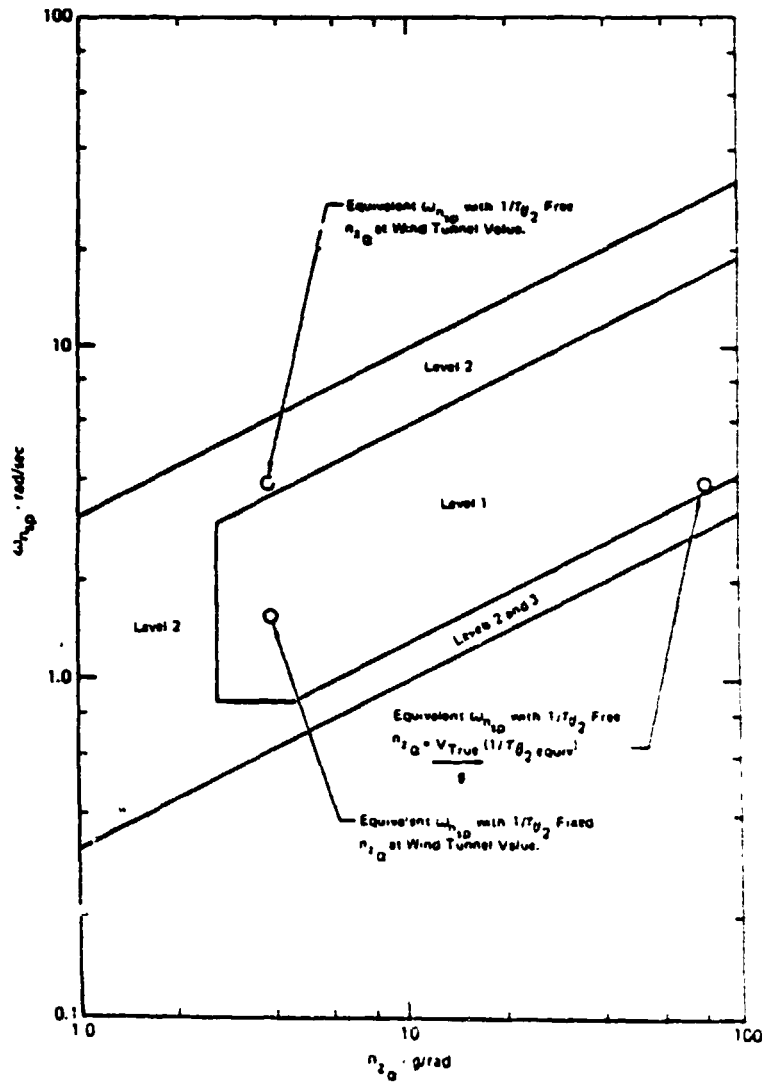
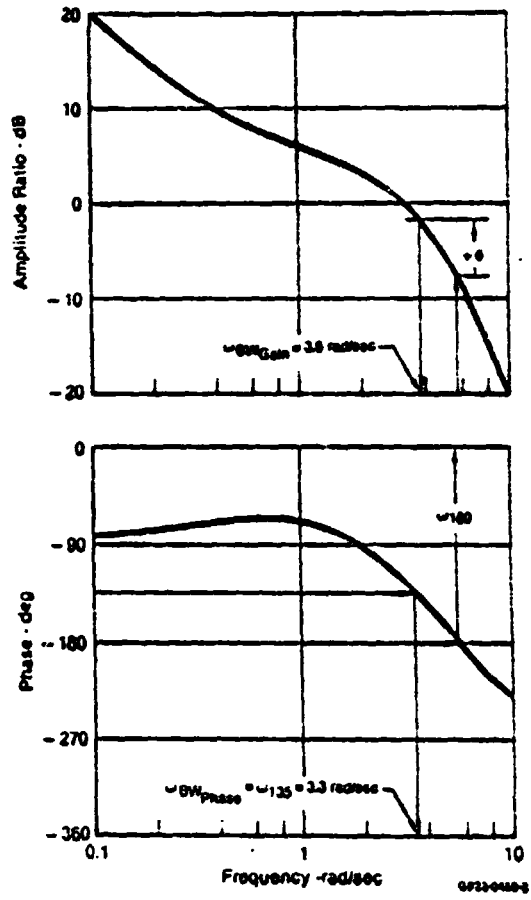

Figure 8. MAPPING OF EQUIVALENT SYSTEMS ON ω_{h10} VS n_{z0} PLANE

Bandwidth (ω_{BW}) is the Lesser of Two Frequencies:

$\omega_{BW} = \min(\omega_{BW}^{Gain}, \omega_{BW}^{Phase})$
 i.e. $\omega_{BW} = 3.3 \text{ rad/sec}$



Definition of Bandwidth for Pitch Angle Response to Stick Force

Figure 9. BANDWIDTH CRITERION DEFINITION OF ω_{BW}

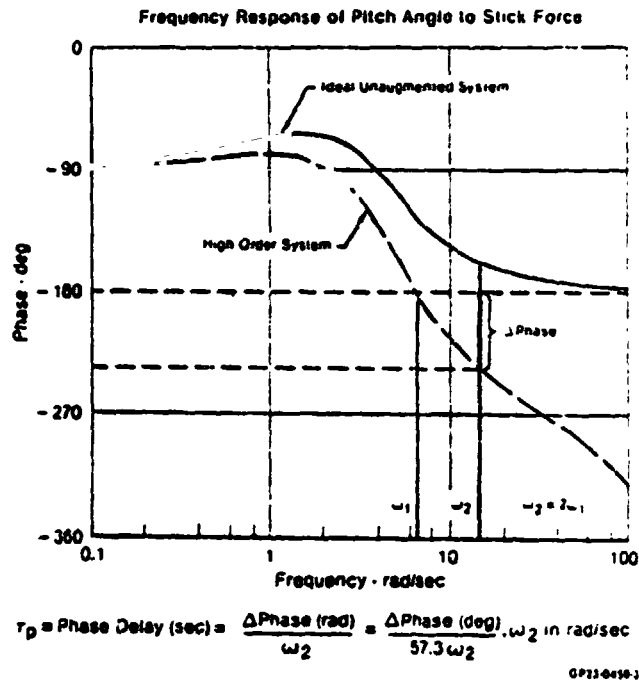

10(a). DEFINITION OF PHASE DELAY, τ_p

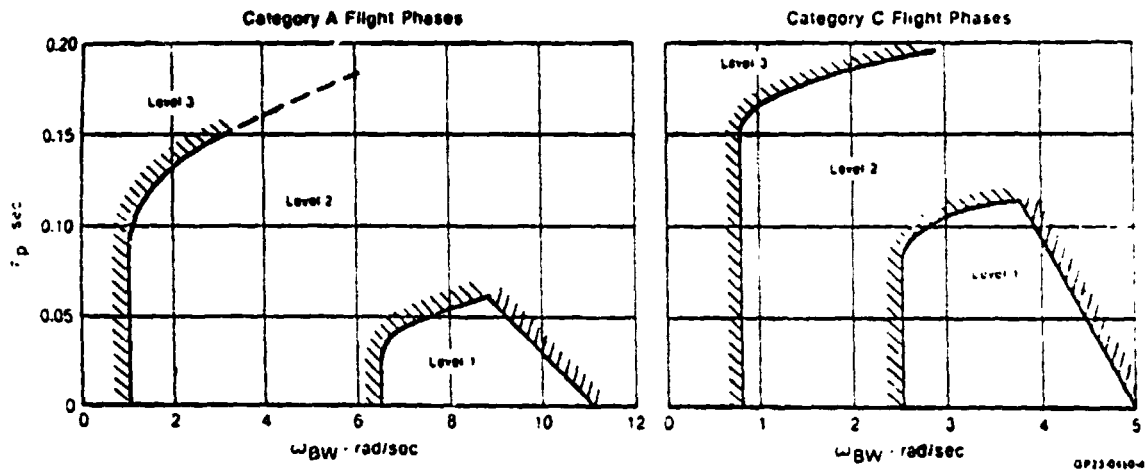

10(b). BANDWIDTH REQUIREMENTS FROM PROPOSED MIL HANDBOOK

Figure 10. BANDWIDTH CRITERION

frequency or high frequency dynamics while maintaining effectively constant mid frequency characteristics. A series of evaluations of so-called supraaugmented configurations were evaluated with a variety of command prefilters. The baseline configuration for this series was a transport type aircraft with a static longitudinal instability. The longitudinal augmentation system consisted of rate feedback with forward loop integral/proportional compensation. A characteristic of this type of augmentation is that a pole of the characteristic equation tends to be driven into, and nearly cancels the pitch attitude numerator zero at $S = -1/ T_{\Theta 2}$.

This pitch attitude zero is replaced, in effect, by the zero of forward loop integral proportional compensation. If this new zero is larger than $1/T_{\Theta 2}$ and close to the augmented short term natural frequency, the pitch rate overshoot normally associated with $1/T_{\Theta 2}$ for a conventional, statically stable aircraft will be suppressed. It is possible to restore the conventional pitch rate overshoot by adding a lead-lag prefilter configured so that its pole cancels the zero of the forward loop integral-proportional network and its zero is approximately equal to $1/T_{\Theta 2}$. This augmentation configuration is illustrated in Figure 11. As can be seen from the pitch rate frequency responses of Figures 12 and 13 for configurations 4-3-7 and 8-3-5, the characteristics resemble those of a conventional aircraft from the mid frequency range on. The phugoid mode, however, has little residue in the rate response and the steady state response to a pitch command is finitewhile for a conventional aircraft the steady state rate response is zero.

The pilot ratings for these configurations were:

Configuration 4-3-7	PR = 7
Configuration 8-3-5	PR = 7, 8

These ratings were heavily influenced by the characteristics exhibited during the flare and touchdown as opposed to the approach portion of the task. The deficiencies cited were a tendency to float and requirement to push forward on the stick to effect the landing. By inserting a washout prefilter with a time constant of 5 seconds a significant improvement in flying qualities was realized.

Configuration 4-3-7-1	PR = 4
Configuration 8-3-5-1	PR = 3,3

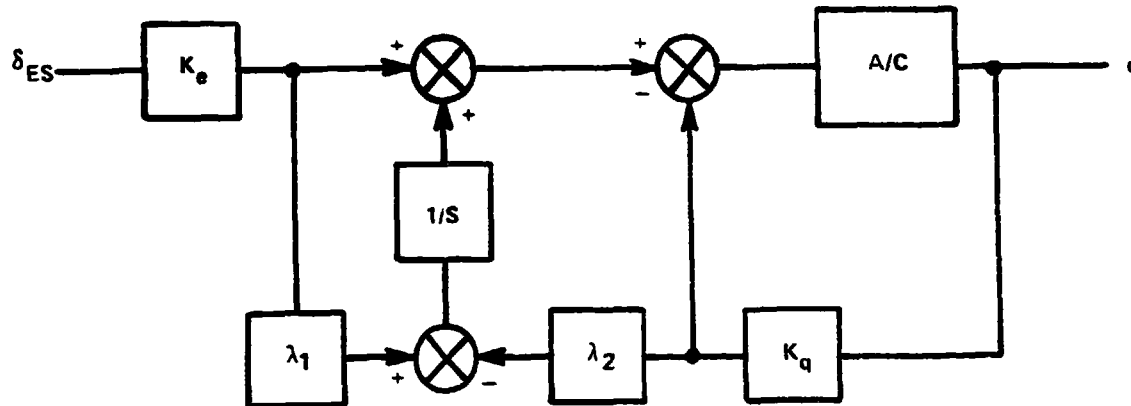

Figure 11. SUPERAUGMENTED CONTROL IMPLEMENTATION

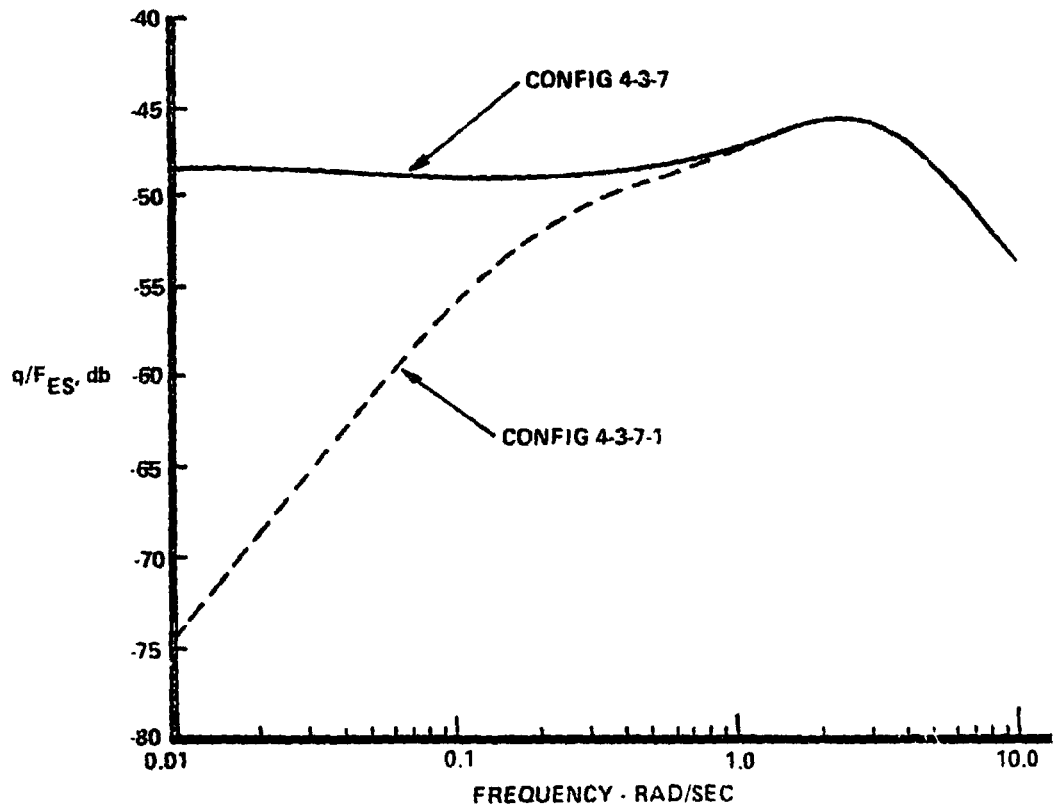

Figure 12. TIFS PITCH RATE PROGRAM-EFFECT OF COMMAND WASHOUT ON RATE RESPONSE

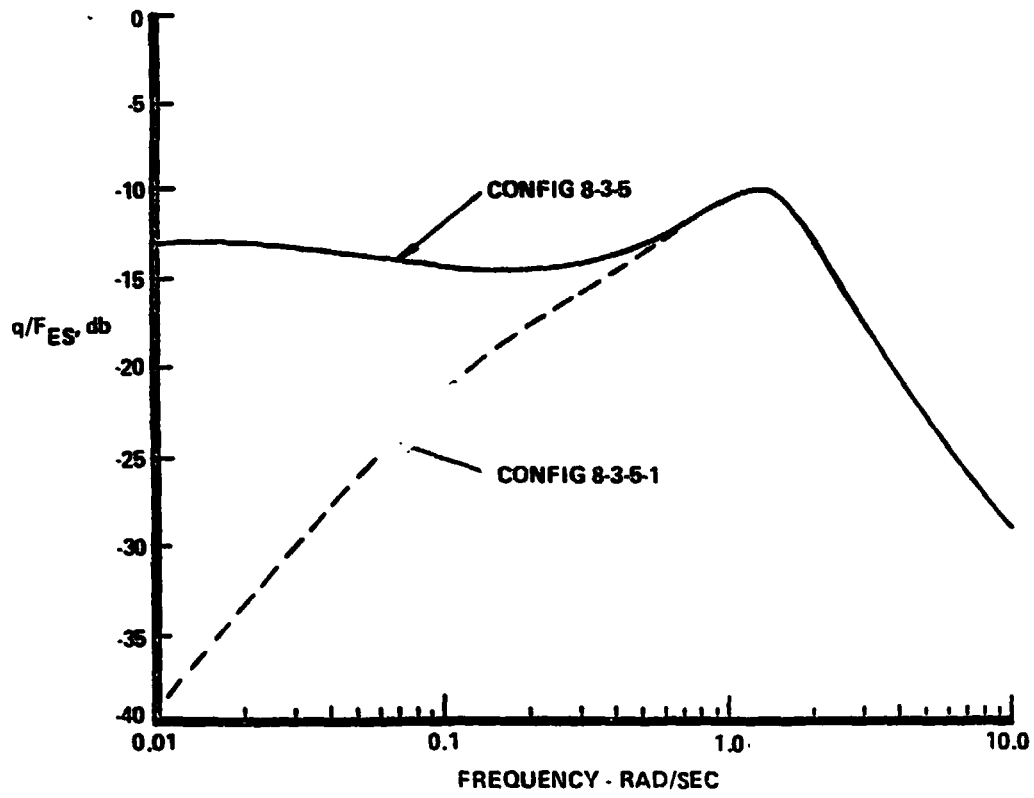

Figure 13. TIFS PITCH RATE PROGRAM-EFFECT OF COMMAND WASHOUT ON RATE RESPONSE

The effect of the prefilter on the pitch rate frequency response can be observed in Figures 12 and 13. In effect, the prefilter has restored a conventional aircraft characteristic to the low frequency rate response. The washout effect can also be observed in the time histories of Figures 14 through 17. Without the prefilter, the response to a step command is a constant pitch rate. The angle of attack transfer functions exhibits a pole at the origin which produces a tendency for angle of attack to ramp in response to a step command (Figures 14 and 16). With the prefilter, the rate response is closer to a conventional aircraft, that is, the long term rate response tends to wash out. The prefilter also cancels the pole at the origin in the angle of attack transfer function so that the system resembles a conventional aircraft angle of attack command response.

The lesson learned from these data is that care must be exercised in applying criteria developed for particular tasks and flight regimes to other situations. Current CTOL longitudinal dynamics criteria are directed toward short term attitude response to control because the data base upon which they were developed was generated in the context of up and away fighter compensatory tracking tasks. The flare and touchdown is a discrete maneuver involving relatively large change in attitude, angle of attack, flight path angle and possibly airspeed. The dominant loop closures utilized by the pilot in this maneuver are not well understood, a fact which is evidenced by the difficulty of simulating this maneuver in ground based simulators.

From a mission/task standpoint, two aspects of the rotorcraft's dynamics are of importance, the response to control and the response to external disturbances. The response to control determines the suitability of the vehicle for situations when the pilot is actively controlling the rotorcraft's speed and trajectory. The nature of the response to control can be tailored both by feedback and by command path prefilters. The response to external disturbances, on the other hand, is a measure of the vehicles' ability to suppress the effects of gusts and turbulence without active pilot intervention. For a given configuration, this aspect of the dynamics can be changed only through feedback (stabilization).

The importance of considering both response to control and stabilization in criteria development can be observed in the results of recent simulations, conducted at Boeing-Vertol in support of the ADOCS program (Reference 17). In these simulations a model following scheme was utilized to simulate a variety of pitch and roll stabilization and

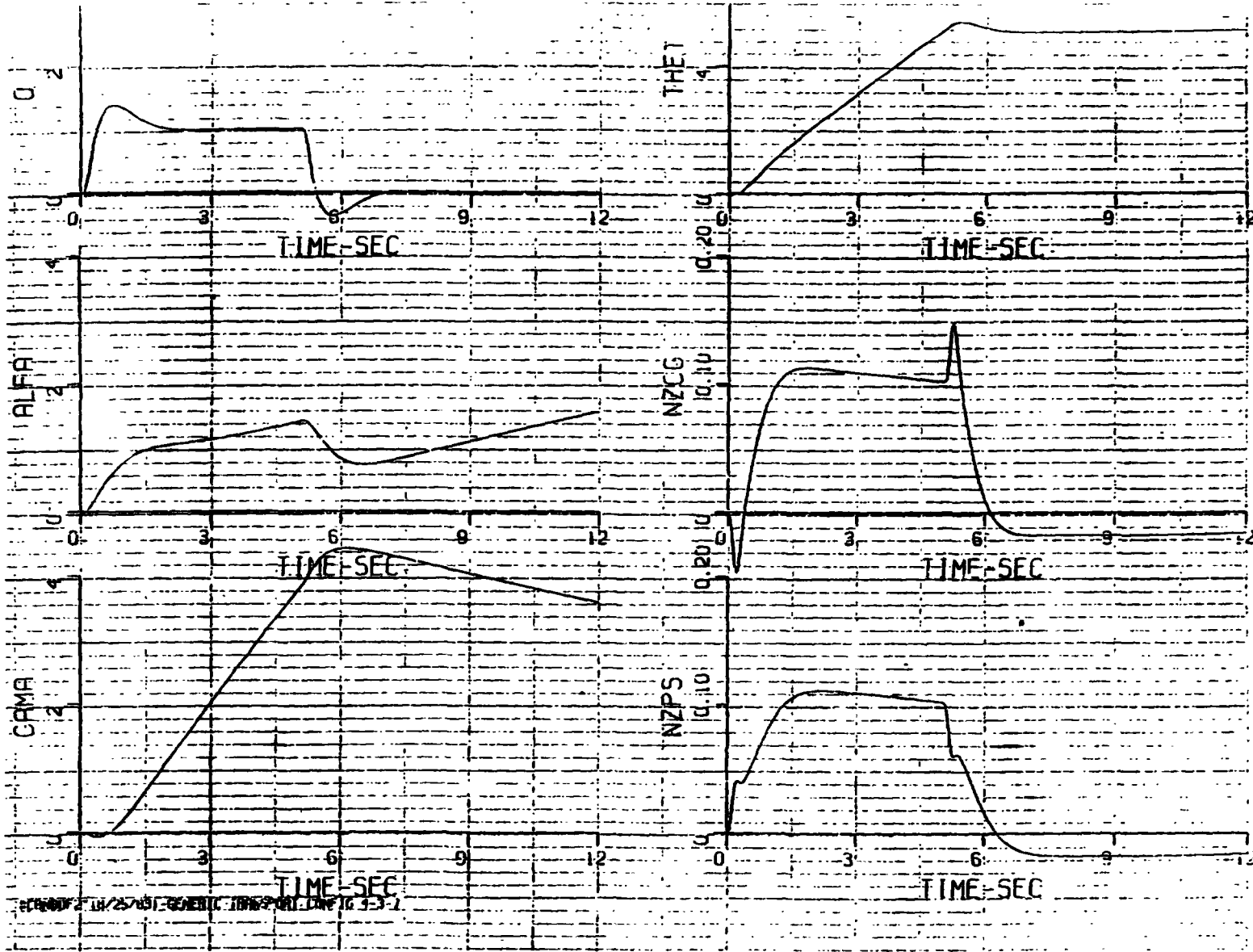

ORIGINAL PAGE IS
OF POOR QUALITY

Figure 14. TIFS PITCH RATE PROGRAM - CONFIGURATION 4-3-7 CHPR=7

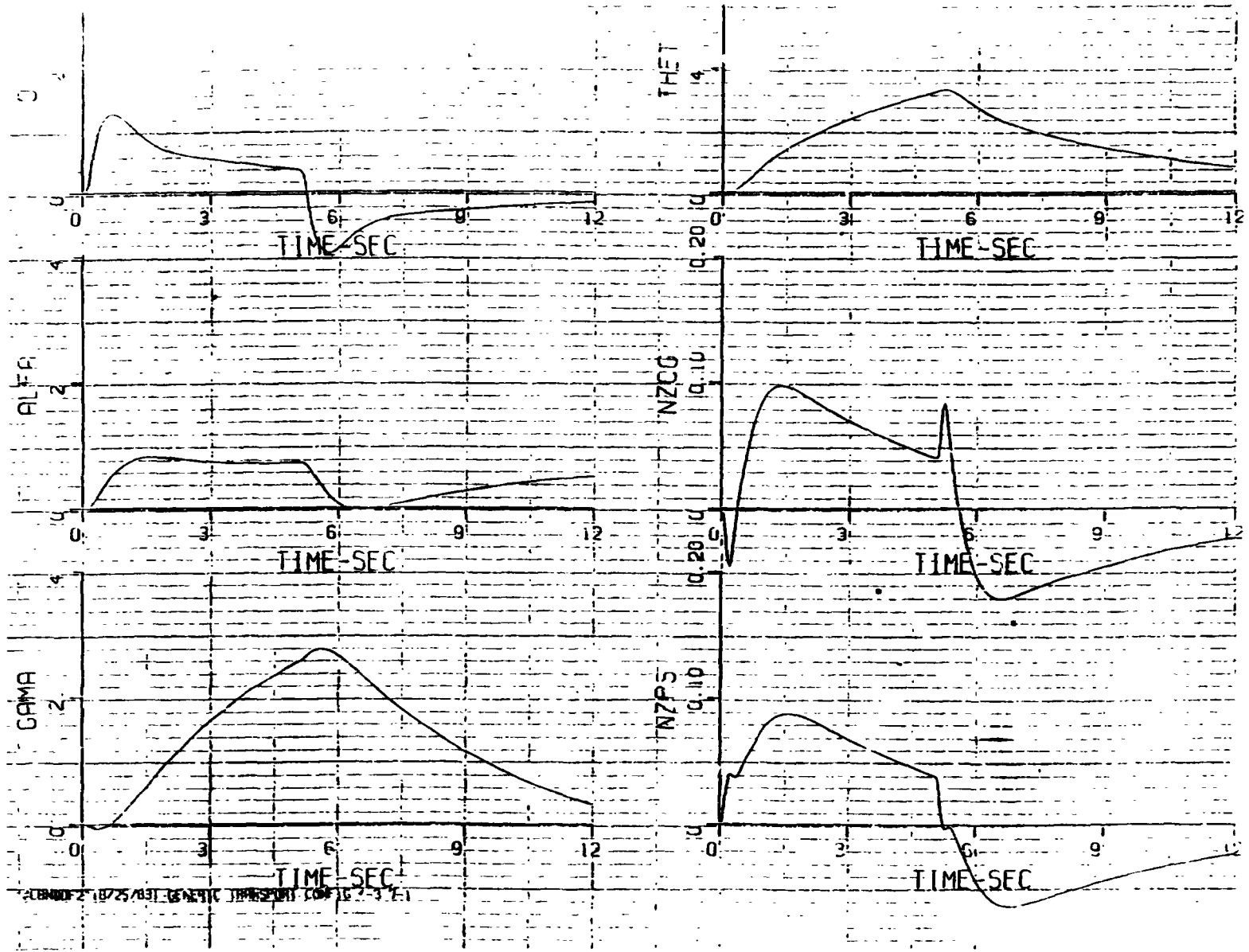

2-10-60 (10/25/63) GENERIC IMPROVED CONFIG 4-3-7-1

Figure 15. TIFS PITCH RATE PROGRAM - CONFIGURATION 4-3-7-1 CHPR=4

ORIGINAL PAGE IS
OF POOR QUALITY

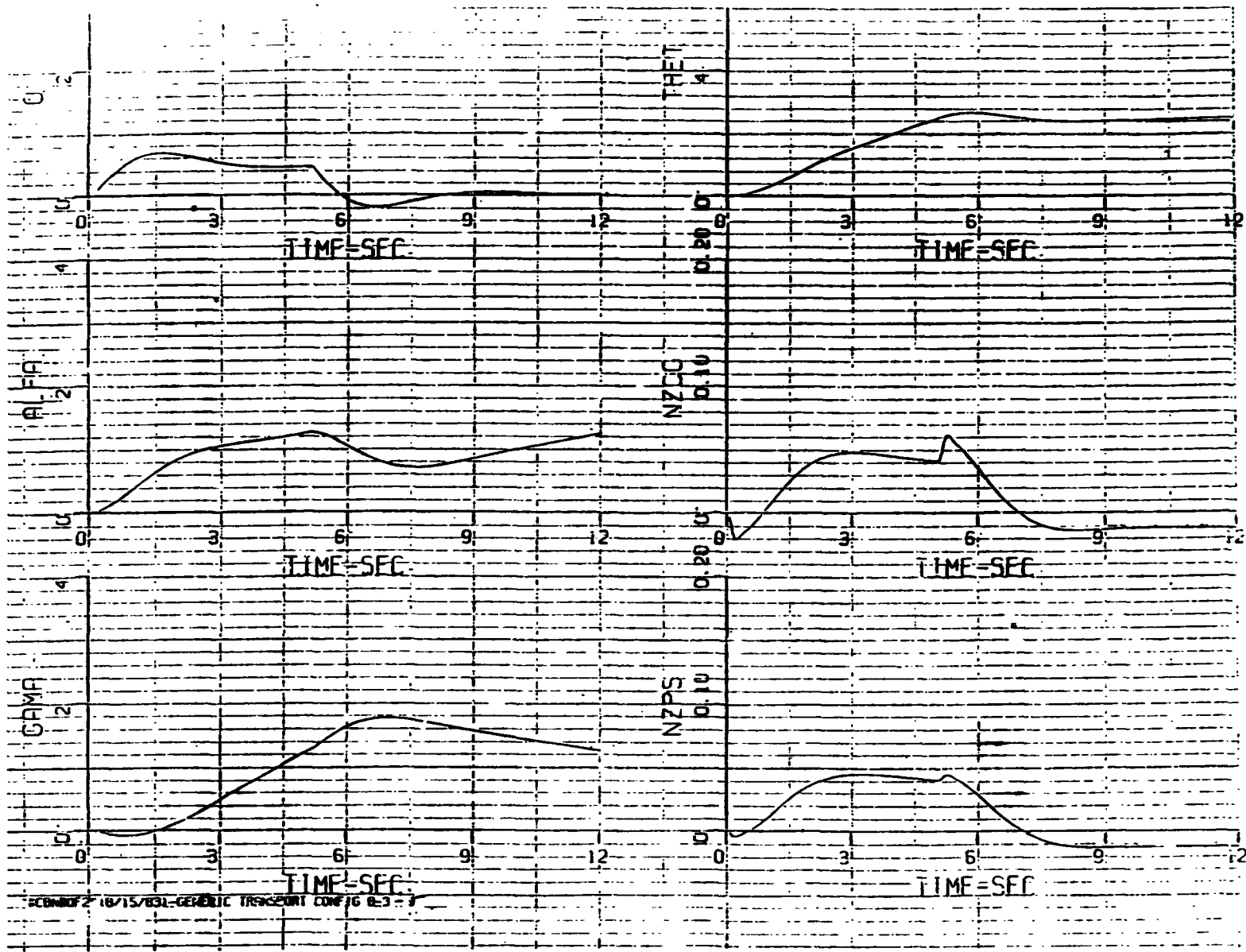
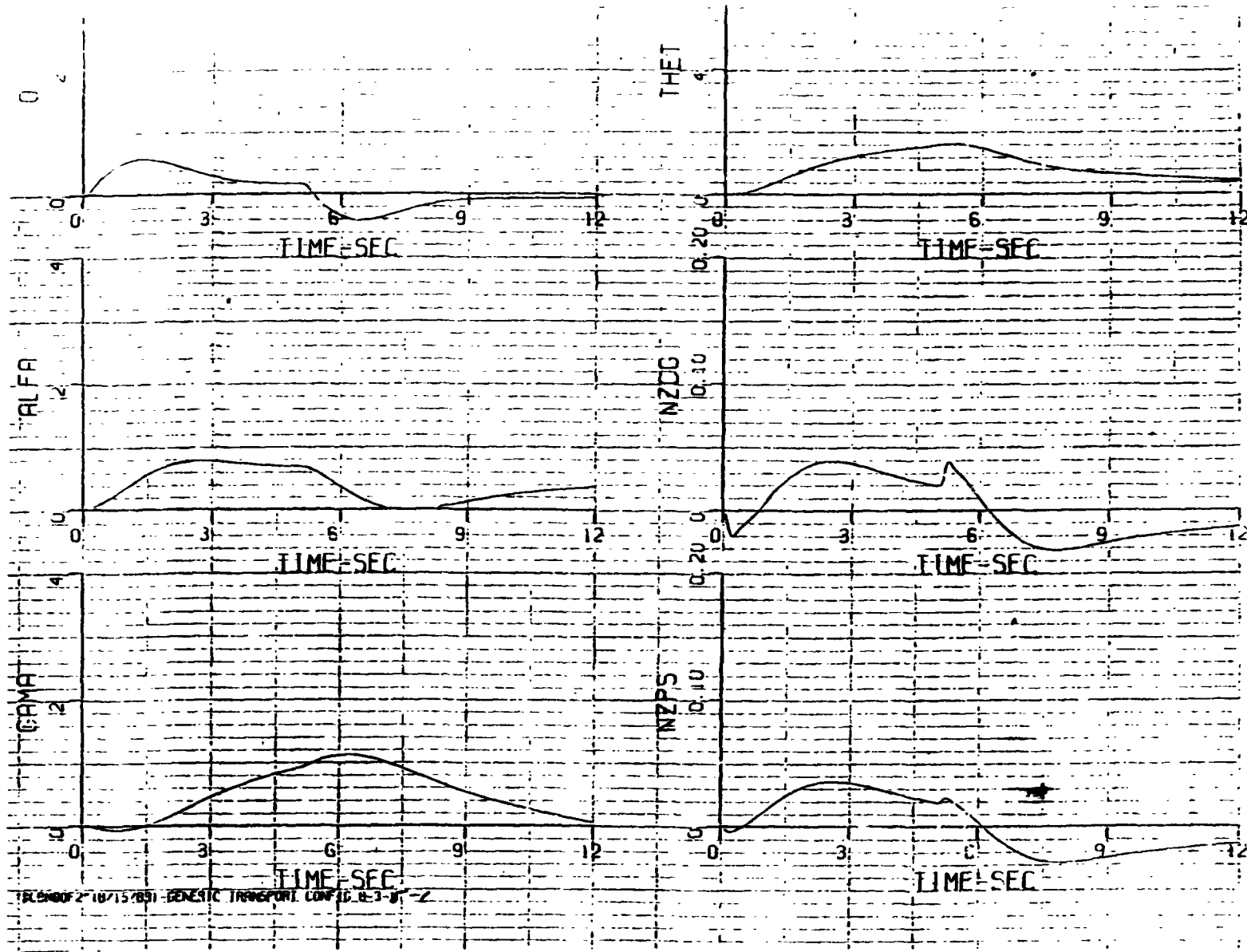

Figure 16. TIFS PITCH RATE PROGRAM - CONFIGURATION 8-3-5 CHPR=7, 8

33



TR 50002 10/15/891 GENETIC TRANSPORT CONF 8-3-81-2

Figure 17. TIFS PITCH RATE PROGRAM - CONFIGURATION 8-3-5-1 CHPR=3, 3

ORIGINAL PAGE IS
OF POOR QUALITY

control response configurations. This control implementation allowed independent variations in both the response to control and the stabilization to be made for a variety of scout attack mission tasks. As can be seen from the examples of Figure 18, angular rate and altitude responses to control command can be realized with both attitude and linear velocity stabilization. The pilot rating results indicate that the flying qualities are a function of both the stabilization and the response to control. Consider, for example, the pilot ratings for the IMC bob-up task with the (3+1)c controller (Figure 19). The configuration RA/AT received an average rating of approximately 7 while changing the stabilization to linear velocity with the same rate response to control (RA/LV) improved the rating to 5. Similarly, changing the control response from angular rate to attitude with linear velocity stabilization (i.e. RA/LV to AT/LV) further improved the pilot rating from 5 to approximately 3. The specific sensitivity of flying qualities to stabilization and control response is highly task and environment dependent.

To illustrate the possible relationship between the generic control/response/stabilization characterization and task and environment factors, consider the hierarchical matrix of Figure 20. A portion of the matrix has been cross-hatched to designate undesirable combinations of control/stabilization. This restriction should be viewed as tentative and is based on results from the Reference 17 experiment which indicate that when the stabilization is more than one integration removed from the generic command type, anomalously poor flying qualities result. See, for example the pilot rating results for the RA/LV configurations presented in Figure 21.

Considering, first the response to control aspects of the matrix, it is likely that tasks requiring rapid maneuvering involving gross changes in airspeed and flight path or position will tend to be best satisfied by angular acceleration or rate type responses to control command. These control responses would usually be preferred for such maneuvering to avoid the design compromises between control sensitivity for small corrections and control authority required for gross changes which would be required with higher level responses such as position or velocity. In relation to the proposed Flight Phase Categorization Scheme, these generic control response types would likely be associated with the maneuvering designation $M = 1$ as indicated on the vertical axes. The P and T designations have been left open although it is unlikely that precision manual control of position/velocity (in the context of NOE operations) could be achieved with such response types. Precision tracking, however, could be achievable via

IDENTIFICATION CODE

	PITCH/ ROLL	YAW	VERTICAL
ANGULAR ACCELERATION	AC	$\ddot{\psi}$	-
ANGULAR RATE	RA	$\dot{\psi}$	-
ANGULAR ATTITUDE	AT	ψ_H	-
LINEAR ACCELERATION	LA	-	h
LINEAR VELOCITY	LV	-	h
LINEAR POSITION	LP	-	h_H

EXAMPLE: RA/AT
ANGULAR RATE COMMAND/ATTITUDE STABILIZATION

$\dot{\psi}$ / ψ_H

YAW RATE COMMAND/HEADING HOLD

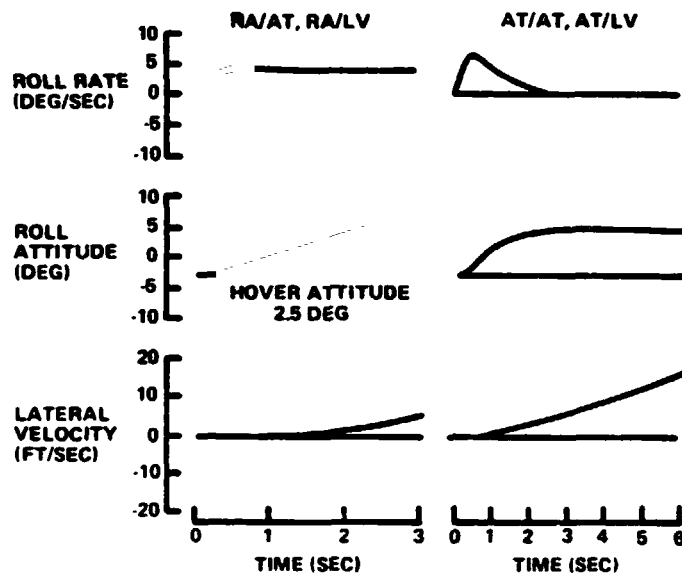

Figure 18 ILLUSTRATION OF INDEPENDENCE OF RESPONSE TO CONTROL AND STABILIZATION

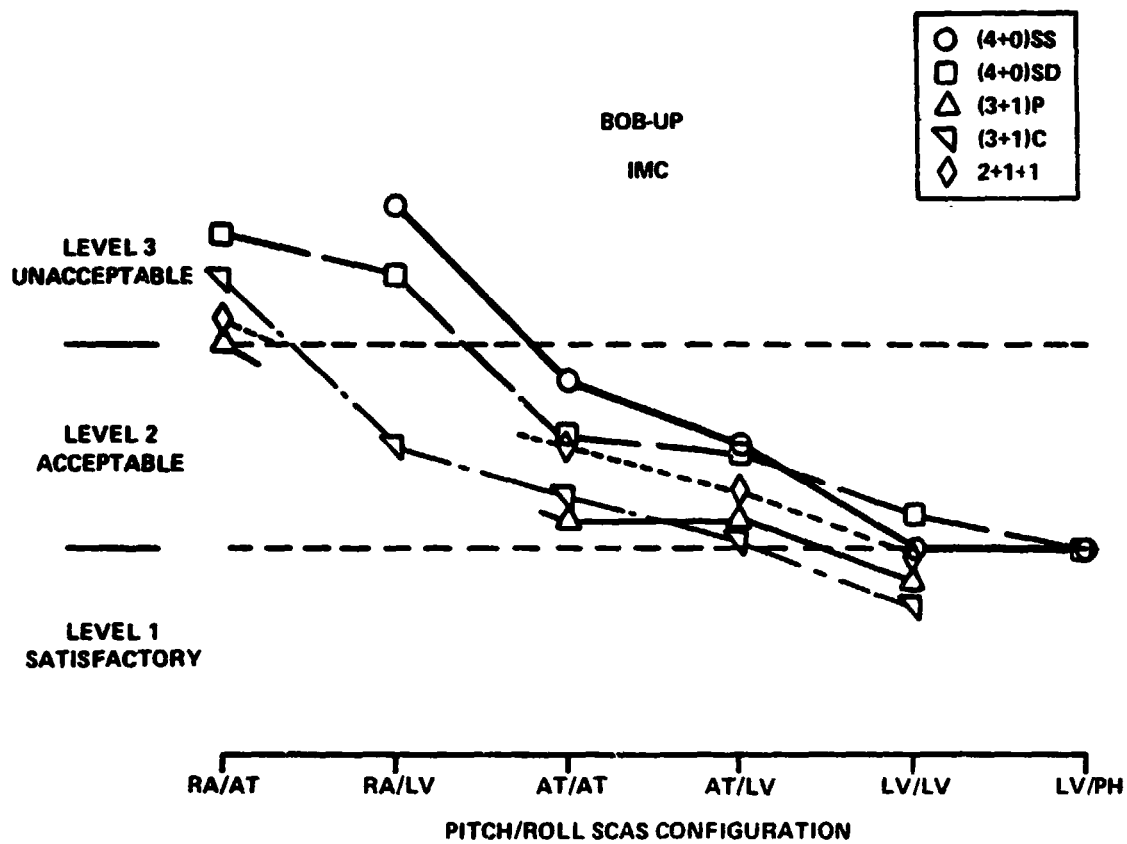

Figure 19 VARIATION OF PILOT RATINGS WITH CHANGES IN GENERIC RESPONSE TO CONTROL AND STABILIZATION-IMC BOB-UP TASK

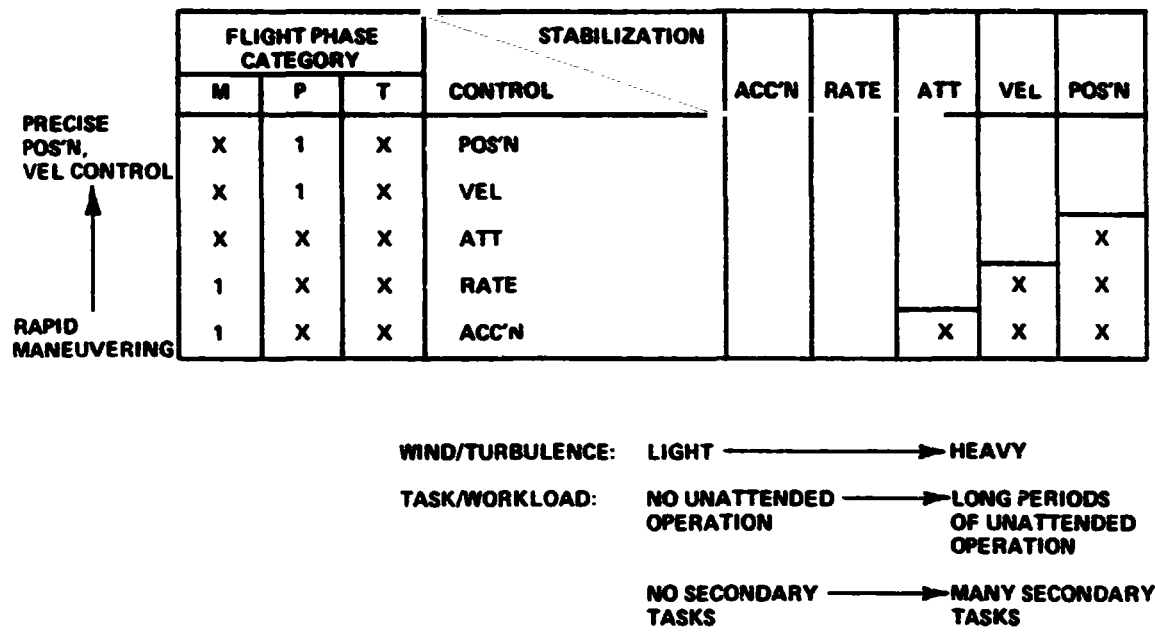

Figure 20 TENTATIVE ASSOCIATION OF GENERIC RESPONSE TO CONTROL AND STABILIZATION WITH FLIGHT PHASE CATEGORIES AND TASK AND ENVIRONMENTAL FACTORS

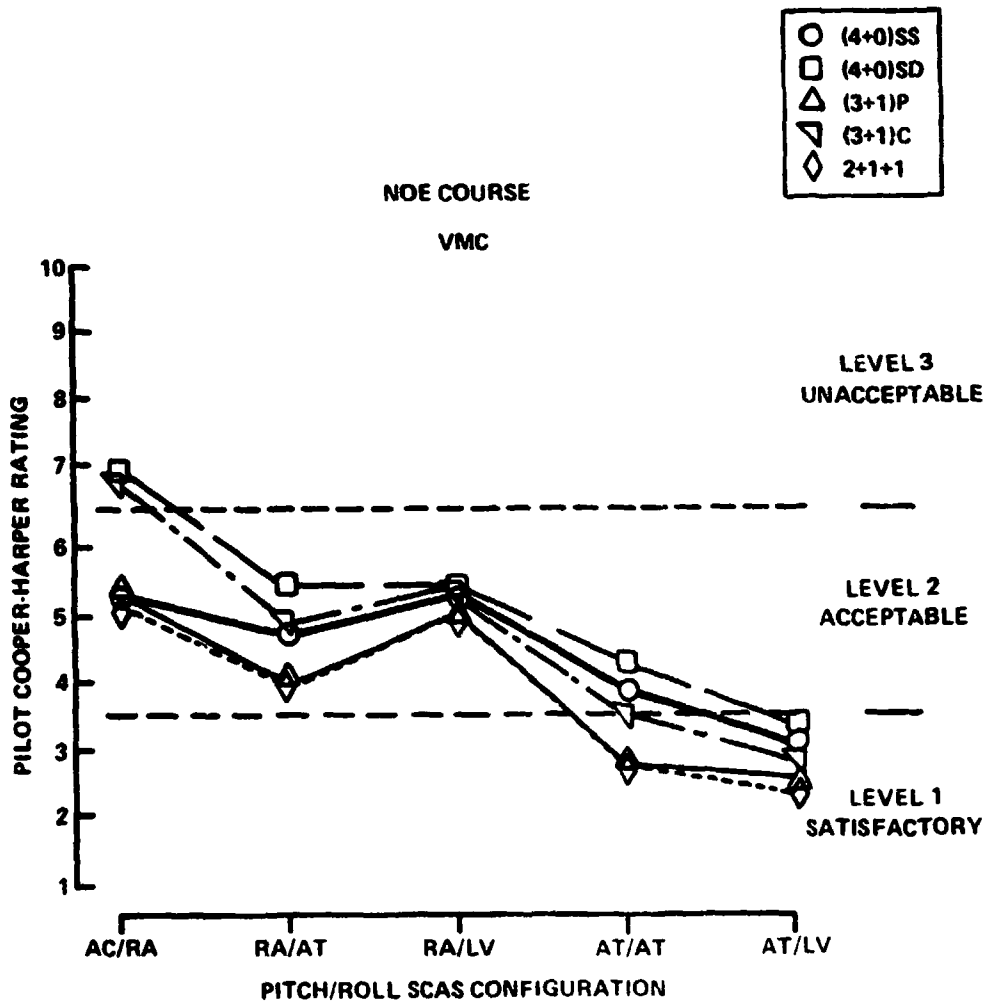

Figure 21 EXAMPLES OF ANOMOLOUS PILOT RATINGS FOR RA/LV SCAS CONFIGURATIONS

independently slewable devices such as swiveling guns or helmet mounted designators or trackers.

Tasks requiring precise position or velocity control (P=1) can likely best be accomplished with velocity or position command control systems. Note that with position or velocity command response types, precision tracking and precise space position control can only be achieved with either independent X-Y force control or with independently controllable tracking devices. For vehicles which must tilt to translate, pitch and roll attitudes are functions of the commanded velocity or position and cannot be independently regulated.

Stabilization requirements will be influenced both by task and environmental factors. Unaugmented (acceleration) or rate augmented systems may be suitable for flight phases involving little or no turbulence, minimal requirements for precision control of position and velocity, and multiple crew (at most small periods of unattended operation and few, if any, secondary piloting tasks). As the wind and turbulence environment degrades or the pilot task loading increases (as for example with single pilot operation) it would be anticipated that the level of augmentation required would progressively increase through attitude to velocity and finally to position stabilization.

It is currently envisioned that the approach to developing flight control criteria for the more demanding Operational Capability Classes (i.e. II, III, IV and IIs, IIIs, IVs) will be first to attempt to define "minimal" augmentation systems in terms of the generic response to control and stabilization required for each Flight Phase. Likely, tradeoffs between control response and stabilization will be possible so there will be no unique or optimum design solution. The critical issue from a design standpoint is likely the minimum level of stabilization required since this aspect dictates the sensor complement. In some cases, this decision will be determined by the information displays necessary for the required Operational Capability Class. For example, the helicopter mine sweeping task requires inertial position sensors to display position with respect to the desired track in the mine field. The designer could, therefore, choose to utilize these signals in the flight control system and couple the rotorcraft to the guidance sensor information. In this case, the decision to utilize this sensor data in the stability and control augmentation system may be made on the basis of flight control system reliability and redundancy considerations rather than flying qualities.

It is proposed to utilize time domain measures as the basis for static and dynamic stability and control requirements. In general, at least two sets of time history responses will be required to characterize a configuration, one to determine the response to control and the second to determine the stabilization (i.e. response to a disturbance). At least two sets of responses are required because with model following control implementations, the vehicle response to a cockpit control command will not reflect the type of stabilization employed. The required test procedure, therefore, would be first to generate responses to each cockpit controller followed by responses to simulated disturbances. This latter step would require the injection of commands into the flight control system at a point which bypasses all flight control system paths associated with cockpit control inputs (for example the control surface servos). Figure 22 illustrates the command input points for control and stabilization determination using the ADOCS demonstrator flight control system block diagram as representative of an advanced control system mechanization.

3.3.2 Sources of Information and Data

Potential sources of information and data for use in developing requirements for the additional Operational Capability Classes are as follows.

- **Applicable new simulation results**

The programs listed in Appendix D are examples of programs which will result in new information sources during the time-frame of the Phase II effort.

- **Flight test experience**

Reports documenting in-flight experiments, flight test of prototype vehicles and testbed installations will be used. Results of many research programs are listed in the bibliography, Appendix E, together with test reports on programs such as TAGS and HLH. Flight test reports on current programs such as the AH-1S, AH-64, XH-59 and XV-15 are available and reports on ADOCS and AHIP are anticipated.

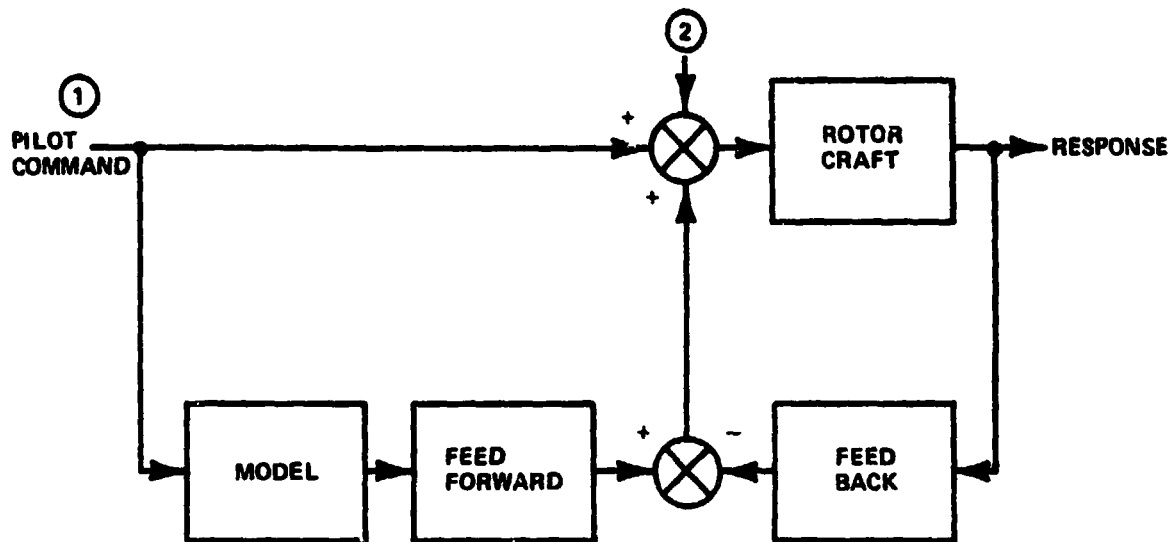

- ① INPUT LOCATION FOR RESPONSE TO CONTROL DETERMINATION
- ② INPUT LOCATION FOR STABILIZATION DETERMINATION

Figure 22 ILLUSTRATION OF INPUTS REQUIRED FOR DETERMINATION OF RESPONSE TO CONTROL AND STABILIZATION WITH ADOCS MODEL FOLLOWING CONTROL IMPLEMENTATION

- **Review of IFR certified civil helicopters.**

A number of civil helicopters have been certificated for single pilot IFR operation in the Forward Flight Region. Examples are the Bell 222 and Longranger II, the Sikorsky S-76, the Boeing Model 234, and the Aerospatiale Dauphin.

Calspan plans to review these civil helicopter certifications with the helicopter manufacturers, the flight control and avionics suppliers and the FAA to establish operating restrictions, avionic equipment used and flying qualities characteristics of the helicopters during IFR operation. This civil experience will be applicable to certain Flight Phase Categories for military rotorcraft.

- **Contact with military and government agencies**

Continued contact will be maintained with military operational and test units and with the government agencies represented on the technical committee. In particular, efforts will be made to learn about current and developing operational applications of rotorcraft; e.g. air-air combat, night NOE, shipboard operations in poor environmental conditions, slung load operations, sled towing, threat avoidance, weapon delivery, etc.

- **Contact with industry**

During Phase I, Calspan let subcontracts to four companies for assistance in developing mission oriented flying qualities requirements for military rotorcraft. In Phase II it is planned to subcontract with helicopter manufacturers for additional assistance in developing requirements for Classes II, III and IV.

Section 4 CRITICAL GAPS

The statement of work for Phase I of the program to develop mission oriented flying qualities requirements for military rotorcraft requires Calspan to:

- Define and prioritize topics not adequately covered by the existing data base.
- Identify available facilities and evaluate their potential for extending the data base required to support criteria.
- Outline experiments to generate new data to address carefully selected critical issues.

Calspan's views on these issues are contained in the following subsections (4.1, 4.2 and 4.3).

4.1 IDENTIFICATION AND PRIORITIZATION OF CRITICAL GAPS

Flying qualities data applicable to Operational Capability Class IV and IVs is the most critical gap for U.S. Army operations. The fact that the Army has initiated the ARTI program and is funding preliminary design and concept formulation studies for the LHX is considered to be verification of this gap in the data base. The critical Flight Phases for Operational Capability Classes IV and IVs are those requiring operation at very low altitude in close proximity to obstacles and subject to enemy threats.

Of particular concern is the workload that may be imposed on the pilot in Operational Capability Class IV - The functional requirements for the LHX pilot are listed in Figure 1. In addition to flight control, the pilot must be concerned with the following function.

- Navigation, both absolute and relative

- Target detection, track and classification
- Indirect fire impact point estimation
- Data management
- Communications
- Threat detection and identification
- Countermeasures management
- Rotorcraft systems management

The lack of data to guide the design of the interface between the pilot and these many avionic systems is a major gap in the data base. The time and attention required of a single crewman to manage and interface with the avionic systems will likely be a large enough fraction of his total capability that it will be necessary to augment the stability of the rotorcraft and to automate much of the flight control activity. Figure 2 contains a tentative list of flight control features and modes of operations that the Army has suggested might be appropriate for a single pilot LHX with Class IVs Operational Capability. Considerable emphasis is placed on automatic hold modes, and switching from one mode to another without significant transients. It is likely that the stabilization and hold modes will be designed to permit pilot fly-through capability i.e. a capability to fly the rotorcraft using the primary cockpit controllers while the stabilization modes are active. There are no requirements in the existing flying qualities specifications that address design of command-hold modes suitable for low altitude operation near obstacles. This is a critical data gap and is considered to be of high priority.

Detection and tracking of targets and flying at low altitude near obstacles in Operational Capability Class IV and IVs will require special sensors, displays, vision aids, and display media. For the purpose of specifications, the vast area of displays can be divided into two families: Vision aids or IMAGE DISPLAYS serve to replace the pilot's lacking view of the outside world. The source of information for such displays may be an optical, infra-red, radar, laser sensor, or even a computer-derived image

from a digital map. The common feature of image displays is reflected in the name: an image resembling a direct view. Information is implicit in an image display and requires interpretation by the pilot. SYMBOL DISPLAYS serve to provide information about specific variables. The source of information for such displays may be an air sensor, gyroscope, accelerometer, navigational equipment, a computer, or other. The common feature of symbol displays is that one or more man-made symbols are used to represent one or more distinct measured variables or commands. The information in symbol displays is more explicit and requires less interpretation by the pilot. In this context, symbol displays range from a simple dial instrument to an integrated HUD.

The distinction between these two families of displays is made because the specifications for them are inherently different. Nevertheless, a combination of the two types of displays, the superposition of symbology on an image display, is quite common in modern aircraft. For such COMBINED DISPLAYS a set of specifications is needed in addition to the specifications for the image and symbol display constituents.

Display specifications can be classified in three groups: information CONTENT, display FORMAT and CONTROLS of the display. The latter two groups are to define, for example, minimum and maximum symbol size, some definition of the clutter, brightness and contrast controls, mode switching, etc. The specifications of information content concern not only the variables and/or the image to be displayed, but also resolutions and ranges where applicable. For an image display, the "range" is manifested in the field of view; the resolution within a given FOV leads to the minification factor and to the required physical resolution of the display medium. For a symbol display, the resolution can be defined in terms of the smallest change in a variable that is to be perceptible; the "range" is then defined by the resolution requirement and the size of the display. If, for example, the resolution requirement is given in terms of percent of displayed value rather than in absolute terms, a non-linear scale allows a wider range within the same scale length. For combined displays in which conformity is required, the accuracy of conformity must be specified in addition to the resolution and range specifications of the constituent image and symbol displays.

The elements of display specifications cited above are certainly not all-inclusive but serve to illustrate the proposed "sub-structure" of display-related flying qualities specifications. The subject of requirements concerning the information content of displays is discussed briefly below.

It has been established by experiments and theory that the information content needed on a display depends on both the task and the control system. In order to achieve a certain path accuracy with a rotorcraft, feedback of a number of variables is mandatory; for example, for precision hovering translational rate must be available, whether derived from the outside view or from a symbol display by the pilot, or whether provided through an autopilot. The implication is that the display information content should be geared to the information needs of the pilot which, in turn, depend on the control system. Considering the set of Level definitions as the common denominator of the flying qualities requirements, the specifications should allow, within limits, for a trade-off between autopilot feedback and display-pilot feedback of a variable needed for satisfactory control. This kind of trade-off may be useful in satisfying Level requirements for failure modes.

There are three important roles that a display system must perform. (1) For a given control system the displays are to provide the pilot information needed to attain Level 1 handling qualities; (2) in failure modes (other than display failures) the displays are to play an important role in mission completion with increased work load or in the safe termination of the flight; (3) in the case of primary display failure a backup display system must assure at least safe termination of the flight. The essence of these points is that from the point of view of flying qualities requirements the display system must be considered an inherent part of the rotorcraft, treated on equal footing with the control system, particularly under degraded visual conditions.

It can be assumed safely that future military rotorcraft will be equipped with relatively large multi-mode integrated displays. Minimum size and resolution, ranges of brightness and contrast, display modes and their controls, information contents, back-up displays should be subjects of specifications. Some of these features, such as ranges of brightness and contrast and back-up displays, can be determined in general flying qualities specifications. Other features depend more on a specific procurement; for such features the flying qualities requirements can only provide a framework for detailed specifications.

The following Table indicates how display features should be included in flying qualities specifications. The Table is not all-inclusive, it is only meant to suggest a systematic approach to the problem.

SYMBOL DISPLAYS	IMAGE DISPLAYS	COMBINED DISPLAYS
Ranges	Field of view	Accuracy of conformity
Resolutions	Resolution	Symbol-image contrast
Symbology (sizes, shapes)	Shades of gray	Clutter limitations
Min. information content	Minification factor	
Clutter limitations		

Common features to all displays are:

- Display modes and mode switching
- Back-up displays
- Brightness range and control
- Contrast control

The information that must be displayed and the format in which it should be displayed are subjects that are under research and development study by many organizations using ground simulators, in-flight simulators, and flight test of prototype equipment. Calspan has been participating in this research effort through in-flight experiments performed in the X-22A, NT-33A, and NC-131H (TIFS) aircraft. All of these airplanes have been equipped with electronic head-up displays used to display information in an integrated format. A recent program performed by Calspan under Navy sponsorship used the TIFS and a prototype wide angle head-up display (HUD) to present the pilot with a pictorial commanded flight path. The display format is shown in Figure 23. The pilot flew the airplane to follow the "roadway in the sky" and the lead airplane presented on the HUD. Pilot response was favorable and indications were that the pilot workload could be reduced and task performance could be improved by pictorial display of trajectory and speed commands.

The symbols used to display approach guidance information on the NT-33A HUD are shown in Figure 24. This display also reduces pilot workload and contributes to improve task performance. The two displays illustrated in Figures 23 and 24 illustrate the gross difference in display format that might be proposed. The task of developing flying qualities criteria so as to account for the effects of information displays is viewed by Calspan as a critical gap for which solutions have not been developed in past specification documents.

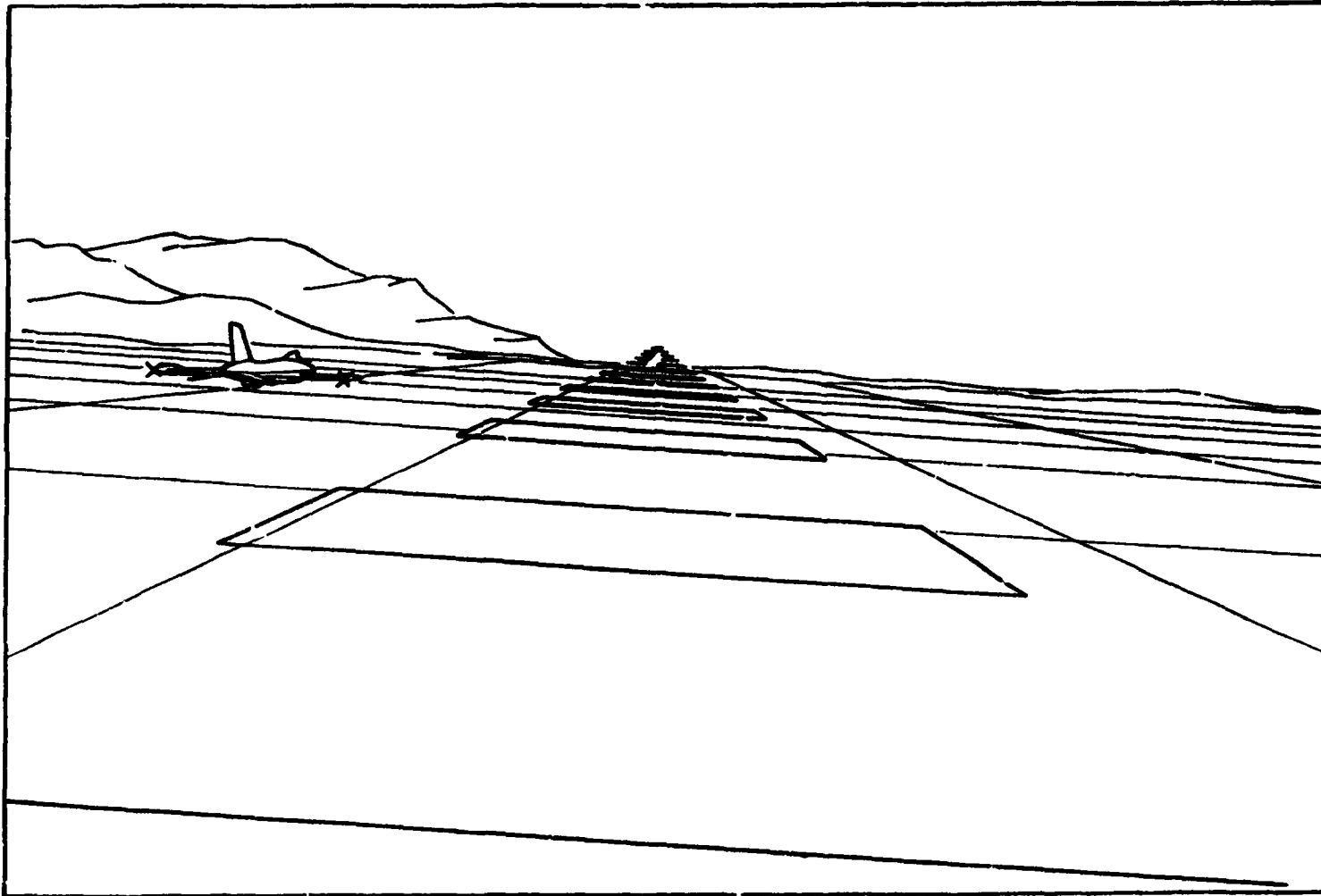

Figure 23 CFPD VERTICAL SITUATION DISPLAY

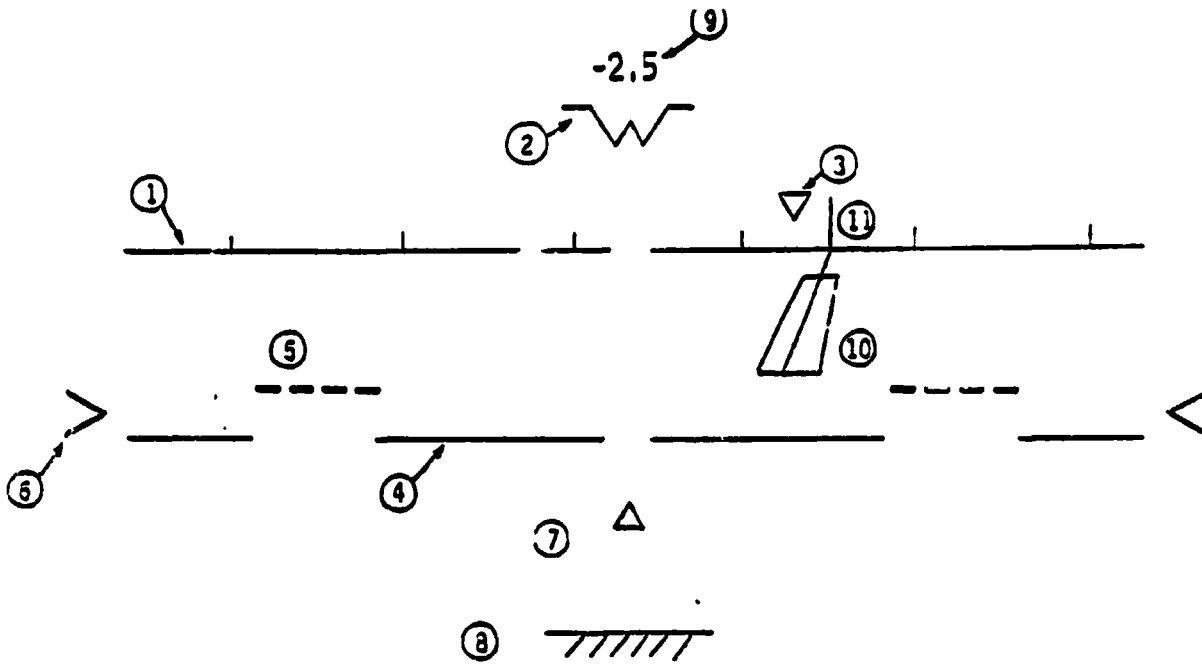

Figure 24 APPROACH HUD FORMAT USED IN NT-33A

1. Horizontal line with 2 deg. heading marks (overlays real horizon).
2. Waterline symbol.
3. Track marker.
4. Air mass flight path marker.
5. Selected flight path marker (depressed below horizon line at glide path angle).
6. Potential flight path marker (airspeed increasing. Airspeed increase will stop if thrust is reduced to lower potential flight path marker to align with flight path marker, or if flight path marker is raised to align with potential flight path marker).
7. Angle of attack triangle. (Angle of attack less than command. Command angle of attack is achieved when apex of triangle is touching the flight path marker).
8. Limit angle of attack. (Limit angle of attack is achieved when limit symbol is aligned with flight path marker).
9. Selected flight path angle (angle between horizon line and selected flight path marker = glide path angle).
10. Synthetic runway (threshold at glide path intercept position).
11. Extended runway centerline.

Criteria for Most Severe Environments

There is a lack of flying qualities data for flight in severe environments. Data to permit specifying the flying qualities parameter values required for Level 3 in the Most Severe Environment (Level 2 for Landing) relative to the parameter values required for Level 1 and Level 2 in the Operational Environment is not available. Data is required for specific Flight Phases (e.g. Shipboard landing, Precision load placement, mine sweeping, etc.) and specific Environments (e.g. wind profiles and turbulence in wakes from ships, buildings, trees etc.). Although air motions are a primary concern, other environmental conditions such as rain, snow, smoke, haze and dust are also important environmental factors because they effect visibility and the function of sensors, vision aids, and radar.

Rotorcraft Operation from Small Ships

Extension of the capability of the Navy and Marines to operate rotorcraft from small ships was a goal of the Navy Vertical Takeoff and Landing (NAVTO LAND) program described in Reference 12. The ultimate goal of the program was to demonstrate automatic landing capability on small non-aviation ships in Sea State 5. An interim goal was to demonstrate a capability to recover rotorcraft in conditions as severe as Sea State 5 with visibility conditions as poor as 700 ft. range with zero ceiling, i.e. operation in fog that obscures the horizon and limits visibility in any direction to 700 ft. In terms of the Operational Capability Classification scheme proposed by Calspan, the NAVTO LAND interim goal would be assigned to Class III.

Although NAVTO LAND is no longer a formal Navy Advanced Development Project, the interim goal of the program provides a focus for research to improve the operational capability of rotorcraft for the Navy and Marines. Reference 12 contains task work statements for each of the following elements

- Flight Controls and Displays
- Guidance Sensor System
- Visual Landing Aids
- Ship Motion Forecasting
- Air Wake Forecasting
- Aircraft Hauldown/securing

- Pilot Techniques
- Simulation
- Flight test

These task work statements identify critical gaps in the information and data required to achieve the NAVTOLAND interim goal. The priority of this research depends on the need by the Navy and Marines for the operational capability expressed in the NAVTOLAND interim goal.

Criteria to Limit Coupling

There is a lack of pilot evaluation data that could be used to formulate criteria to limit coupling phenomena. There are many sources of coupling, especially in the case of single rotor helicopters. Coupling can result from control derivatives such as Z_{δ_e} , X_{δ_e} , N_{δ_a} , L_{δ_r} , M_{δ_e} , N_{δ_c} ; angular rates derivatives such as M_p , L_q , L_r , N_p ; linear velocities derivatives such as X_w , Z_u , M_u and L_v . In hover, M_w and N_v can be considered to be contributors to coupling. Combinations of the coupling terms can be involved in determining the magnitude and phase of the dynamic modes appearing in the coupled responses resulting from control commands or external disturbances.

The degree to which flying qualities are degraded by coupling phenomena is dependent on the tasks and environment associated with a given Flight Phase. The flying qualities for tasks requiring aggressive maneuvering are likely to be degraded most by coupling. The degradation caused by winds and turbulence can be exacerbated by large values of "coupling" derivatives and may limit performance in precision control tasks. Flying qualities data available are inadequate to permit formulation of quantitative criteria to limit coupling phenomena.

Thrust Response and Rotor RPM Control

Because a conventional helicopter produces thrust through modulation of blade pitch angle, the response to thrust commands is, in effect, instantaneous. Thrust transients can occur after the initial response which are associated with lags in the governing system loop as it modulates engine power to maintain the rotor speed.

Since existing criteria for height control are based on the thrust response characteristics of jet lift VTOL's, which can exhibit significant lags and time delays in the initial thrust response, the applicability of these criteria to helicopters is questionable. Several piloted simulation programs have been conducted by NASA Ames to provide a data base for height control criteria specific to helicopters (References 18 and 19). Parameter variations included the bandwidth of the engine/governor system, rotor stored energy (inertia), vertical velocity damping and sustained thrust to weight ratio. Task loading associated with pilot monitoring and control of RPM was also examined by removing aural and displayed RPM cues for selected configurations. The dominant parameter was found to be the engine/governor bandwidth which, if too low, resulted in sluggish vertical velocity response and excessive RPM transients in response to collective commands. Since the pilot rating degradation was considerably higher with RPM cueing than without, it can be concluded that concern and/or difficulty with the regulation of RPM transients is possibly a more significant or more noticeable effect of low bandwidth governing than is the degraded height control characteristics. At the point where the RPM transients become so large that pilot intervention is required, there will also be a pilot induced degradation in height control characteristics because the pilot can only correct an overspeed or underspeed transient by reversing his collective control command.

From a criteria standpoint, it appears that, in addition to limits on vertical control sensitivity and damping, additional limits are required on the allowable RPM transients during maneuvering flight. The results of Reference 19 suggest that the pilot's sensitivity to RPM transients is related to both the transient magnitude and the rate of RPM recovery. That is, relatively large transients are tolerable if the recovery is sufficiently rapid. The data of References 18 and 19 should be surveyed to formulate allowable RPM transient limits.

In light of the fact that the tilt-prop rotor configuration is under consideration for Army and Marine missions, i.e. LHX and JVX, a parallel analytical and simulation program should be conducted to examine the thrust and RPM dynamic response characteristics which may be exhibited by these vehicles in hover and low speed flight. The RPM governor for a tilt rotor aircraft must accommodate both helicopter and conventional airplane modes of operation. In high speed flight, with the flow directed axially through the rotor disc, the sensitivity of thrust to blade pitch is so high that a helicopter type collective pitch thrust control with power RPM governing is not

practicable. A solution is to employ an airplane propellor speed governing scheme as indicated in Figure 25. This was the approach employed both for the Bell XV-15 and for the X-22A. As part of a study of the suitability of the XV-15 aircraft for flight research applications, Calspan conducted linear analyses of such a governor system (Reference 20). The following data are based on the results of that study. In contrast to the helicopter governor, a propellor speed governor functions by using blade collective pitch modulation to regulate RPM as opposed to engine power. Neglecting, for the moment, the effect of cockpit collective to blade pitch feedforward, the response of thrust to a command is as follows. A cockpit collective input commands engine power output which, in turn, accelerates the rotor speed. The governor senses the speed error and modulates the blade pitch to absorb the change in engine power (torque). If the governor uses integral as well as proportional compensation on RPM error, the blade pitch will change until the error is nulled. Thus, increased power output will be accompanied by increased blade pitch and thrust and vice versa. Dynamically, the thrust will tend to follow the engine power output and will be largely determined by the engine power response and the governor blade pitch loop dynamics. Figure 26 illustrates the thrust, power and RPM response for the situation of a restrained rotor. The thrust response dynamics are similar to those of a jet lift VTOL. While this is a satisfactory solution for cruise flight, in hover and low speed missions such as NOE, the thrust response lag could seriously degrade flying qualities. A remedy for this sluggish thrust response, which is incorporated in the XV-15 governor, is to utilize a collective pitch feedforward path which provides instantaneous blade pitch and thrust response in advance of that commanded through the governor feedback path. With this compensation, the thrust response dynamics are a function of relative magnitude of the power and collective feedforward gains as well as the engine power and governor loop dynamics. The thrust and RPM transients tend to be minimized for relative gains such the power commanded by cockpit collective is equal to the rotor power required increase due to the feedforward of blade collective pitch. Even with this "ideal" gain condition, some excitation of governor activity and thrust and RPM transients takes place because of differences in the dynamics of the collective feedforward and governor feedback paths. These trends are illustrated in Figures 27 to 29. Selection of feedforward gains to minimize thrust transients will require identification of the change in power required with collective pitch together with flight control system gain scheduling since this coefficient will vary significantly with flight condition. Notice also from Figure 27 that for feedforward gains less than the "ideal" gain the maximum RPM transient is opposite in sense to that observed for a helicopter power governing scheme.

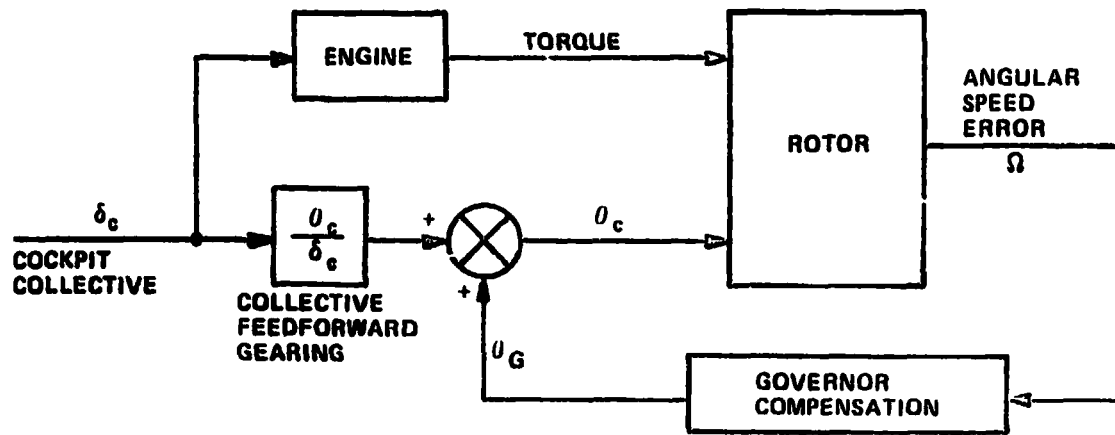

Figure 25 BLOCK DIAGRAM OF ROTOR SPEED GOVERNING SYSTEM USING ROTOR COLLECTIVE PITCH

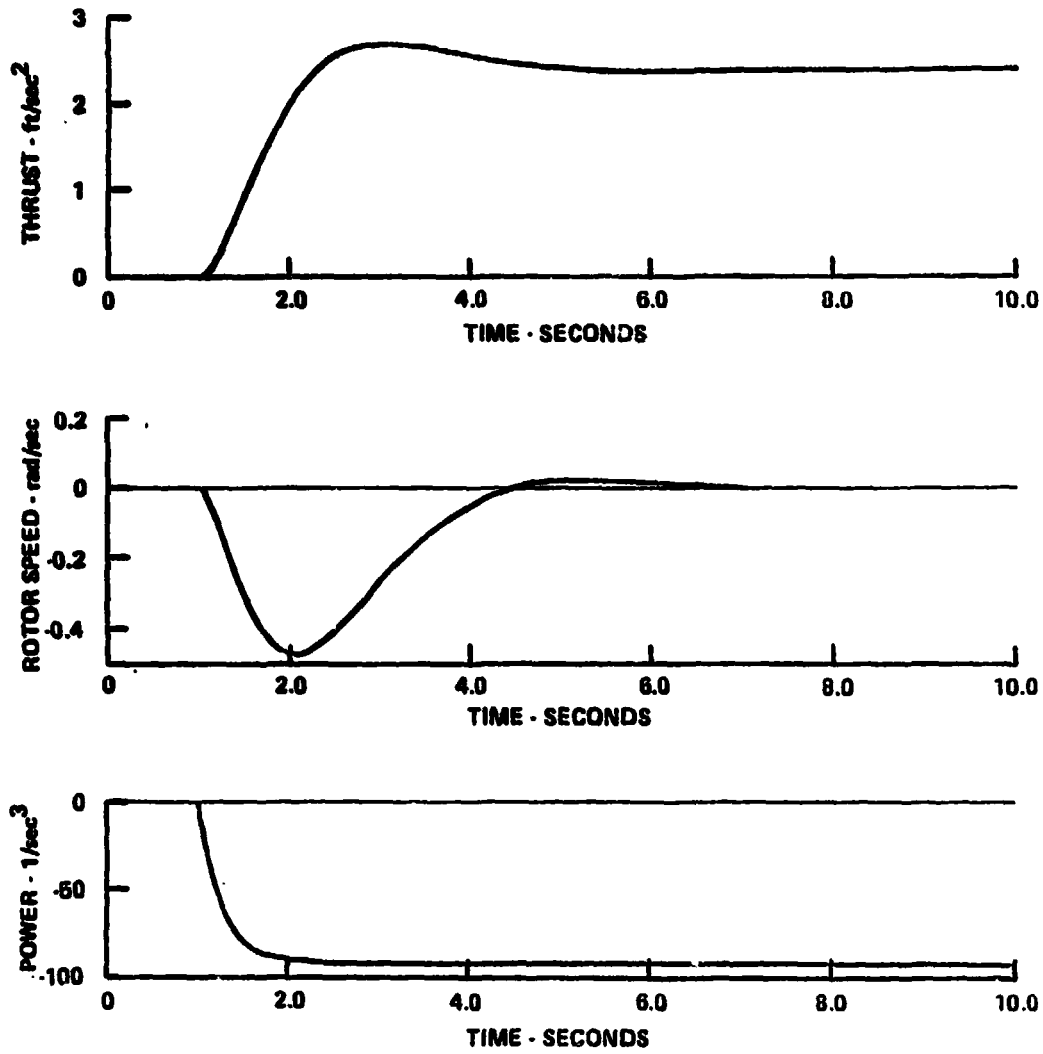

Figure 26 ROTOR THRUST AND SPEED RESPONSE TO COLLECTIVE COMMAND - NO COLLECTIVE PITCH FEEDFORWARD

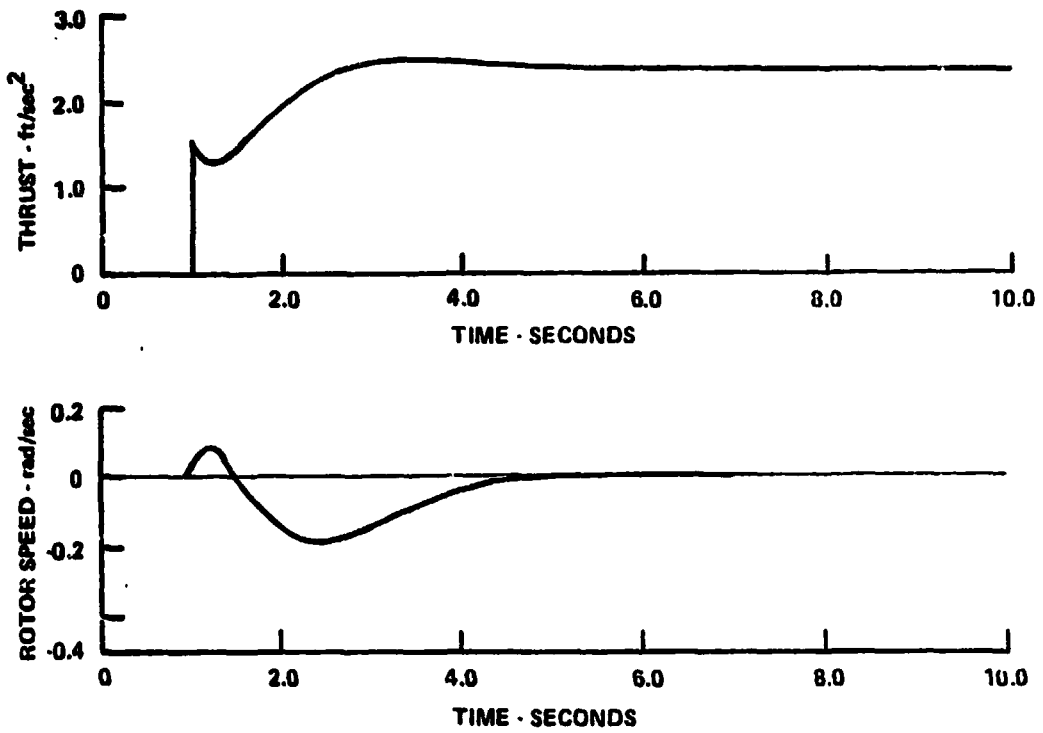

Figure 27 ROTOR THRUST SPEED RESPONSE TO COLLECTIVE COMMAND - COLLECTIVE PITCH FEEDFORWARD COMMAND EQUAL TO 67% OF "IDEAL" GAIN

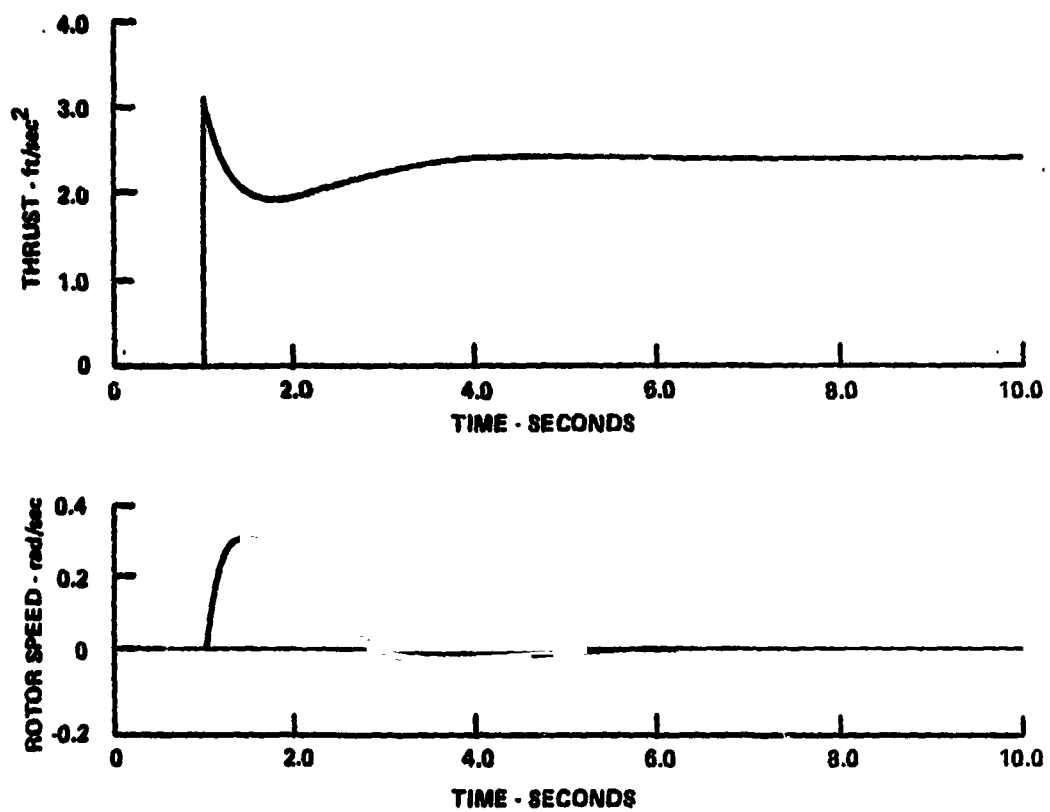

Figure 28 ROTOR THRUST AND SPEED RESPONSE TO COLLECTIVE PITCH COMMAND
COLLECTIVE FEEDFORWARD GAIN EQUAL TO 133% OF "IDEAL" GAIN

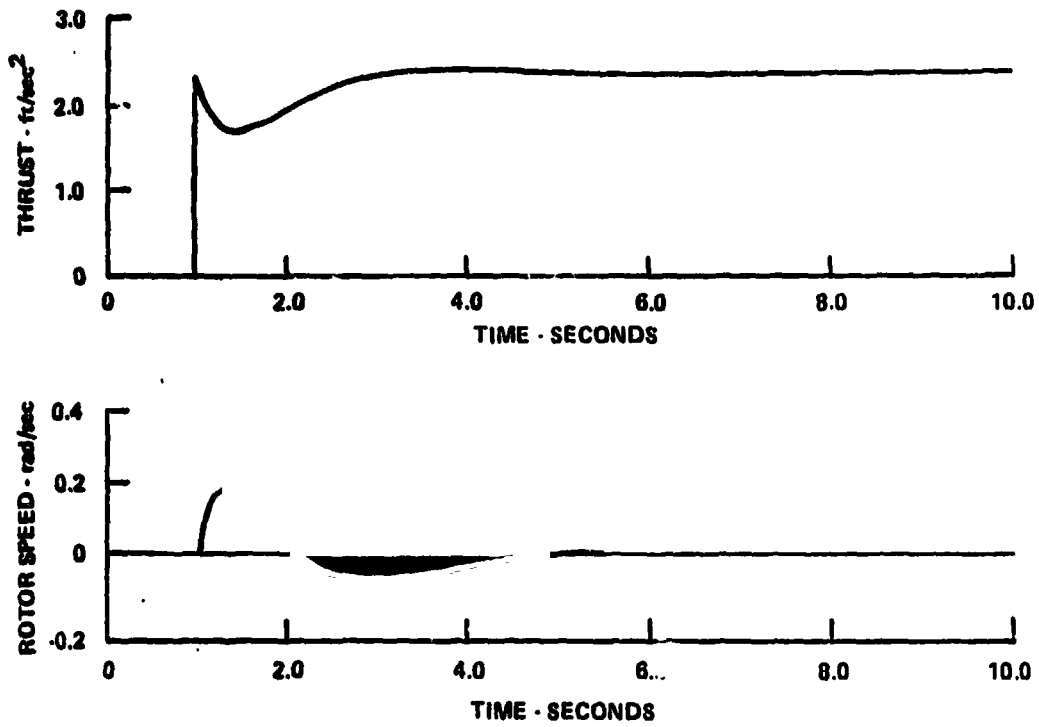

Figure 29 ROTOR THRUST AND SPEED RESPONSE TO COLLECTIVE COMMAND - COLLECTIVE FEEDFORWARD GAIN EQUAL TO "IDEAL" GAIN

That is, increased collective produces overspeed transients and vice versa. However, for feedforward gains greater than "ideal", the opposite is true. Increased collective produces droop transients as with a power governing scheme. This trend suggests that manual recovery from excessive RPM transients may be extremely difficult with this type of governing scheme since the pilot has no precognitive sense of which way to move collective to correct the overspeed or droop in RPM.

The proposed simulation program should have as its goal the generation of data for the development of criteria for height control of rotorcraft with blade collective pitch governing. The simulation tasks should be based on the NOE maneuvering utilized in the previous NASA studies. Parameter variations should include:

1. Engine power response dynamics
2. Governor loop compensation
3. Relative magnitudes of cockpit collective to blade pitch and to power gains

Specification of Dynamic Response Characteristics

The use of powered controls and high authority series servos in flight control systems creates the possibility to augment the stability and control characteristics of the rotorcraft through feedforward, crossfeed and feedback of measured control and response parameters. The available technology permits augmenting or suppressing the normal aerodynamically generated moments and to some extent the aerodynamic forces. This capability permits augmenting and tailoring the natural modes of motion and response to controls so as to improve the flying qualities. Through use of inertial sensors, guidance signals and rotor state measurements it is possible to suppress responses to disturbances and coupling and to create new dynamic modes of response to control. The development of flight control technology in recent years has tended to out pace the development of flying qualities design criteria. Currently, there is a lack of substantiated criteria applicable to design of control systems using inputs such as inertial sensors, guidance signals, logic functions or sensor blending as a function of frequency. Current flight control technology, to a large extent, permits independent design of the response to control and the stabilization i.e. which states tend to be maintained when the control commands are zero and to what extent external disturbances are regulated.

Historically the stability and control and flying qualities disciplines were treated separate from guidance and control or automatic control. The current flight control technology and design practice tends to remove this separation of the technical disciplines and also blurs distinction between piloted control and automatic control since both can be active at the same time. There are many choices available to the flight control system designer and there are many factors such as Level 1 flying qualities, degradation of flying qualities associated with failures, reliability, cost, maintainability etc. which must be considered in selecting a design concept. When control laws are implemented which use non aerodynamic sensors there is the risk of exceeding aerodynamic and structural limits of the rotorcraft during operation. To prevent dangerous conditions, it may be necessary to incorporate aerodynamic or air data sensors and logic or limiters in the control system. There is a gap in the flying qualities data base which inhibits formulation of design criteria for highly augmented rotorcraft. Generation of data for this technical area should be given high priority.

Inner Loop and Higher Derivative Limits

When signals such as space position, inertial velocity, orientation angles, guidance errors etc. are used in control laws it is often necessary to incorporate limits or to choose system gains so as to limit inner loop parameters or higher derivative responses at particular locations in the vehicle. The following examples illustrate the need for system limits. If roll damping is made too high, the angular and linear acceleration at the pilot station can cause the pilot to couple with the response and a phenomena referred to as roll ratchet occurs. Pitch and roll attitude excursions of unacceptable abruptness and magnitude can occur during transients following pilot commands to translational rate command systems when loop gains are high. Commands for large position changes, initial conditions at engagement of a position hold mode or failure of position sensors or computers can result in large commands to the flight control system which could result in extreme angular responses unless the design includes some form of signal limiting or logic which gives priority to inner loop responses and higher derivative responses. Some of these inner loop limits can probably be chosen on the basis of engineering judgement but others are more subtle and depend on the pilot's capabilities and tolerance to motions not directly commanded. There is a gap in the data relating to the pilot's sensitivity to acceleration cues at the pilot station and his tolerance for inner loop or higher derivative motions not directly commanded by his control actions. It is thought that valid data in this area can best be derived from

flight test and in-flight simulators. The need for data in this area is primarily to prevent over design of the response dynamics and to prevent omission of needed limits through oversight.

Nonlinear Command Gradients

Past specifications have generally encouraged linearity between rotorcraft response and the command from the cockpit controller. There may be circumstances, however, where a nonlinear command-response gradient with amplitude is more appropriate. Examples are roll rate response to lateral cyclic commands and translational velocity response to cyclic commands. In the U.S. Army Heavy Lift Helicopter program, the load controlling crewman commanded the translational velocity response with a small finger held control stick through a nonlinear command-response gradient. For small inputs the commanded velocity vs controller deflection gradient was low but for large inputs the commanded velocity vs controller deflection gradient was high. This configuration permitted commanding reasonably high velocity for air taxi but also provided a lower gradient for small stick deflections which was necessary for precision control of the external load position relative to the ground. Although there are examples of cases where nonlinear gradients were found beneficial in specific programs, there is no general theory for determining when a nonlinear command-response gradient is appropriate and there are no design guides for establishing the shape of the nonlinearity that would be appropriate for a specific application. This data gap should be addressed at the same time data is developed to define the dynamic criteria for highly augmented rotorcraft.

Environment Models

The draft specification document prepared by Calspan, Appendix A, contains definitions and mathematical models of a number of environmental conditions. These math models are based on available data which in some cases was taken from wind tunnel tests on small scale models of ships or tree configurations. These models should be extended to define the air wake for more classes of ships and for lateral wind variations between trees and buildings together with turbulence magnitudes in these wakes. To the extent feasible, these models should be verified or validated with full scale measured data.

Most experimental turbulence experiments have concentrated on single point measurements of the three orthogonal components of turbulent airspeed in order to quantify the parameters of one-dimensional spectral models such as the Dryden or Von Karman forms. These models are satisfactory at high altitudes where the assumptions of isotropy and homogeneity apply. These spectral models have also been applied to intermediate and low altitudes (i.e. within the surface boundary layer) where the flow is neither homogeneous nor isotropic. Experiments have indicated, however, that the one dimensional spectral density functions are expressed as functions of altitude. If the time of passage of the aircraft through the turbulence field is short, the turbulence can be considered constant and gust spatial gradients can also be determined from time derivatives of the orthogonal gust velocity components. The gust gradients, therefore, are correlated with the gust components at a point and, in general, produce significant forces and moments only at very high speed.

In wake turbulence the flow characteristics are not statistically well behaved and the assumptions of isotropy and homogeneity certainly will not apply. The variations in the orthogonal velocity components as well as the spatial gradients about each point in the wake will be strong functions of the obstacle shapes and spacings. Furthermore, it is unlikely that the first and high order gust gradients will be correlated with the uniform components. Although the Navy has sponsored wind tunnel measurements and wake turbulence model development for the small ship environment, these models are expressed in terms of the statistics for the three components of the mean and random wind components as functions of position in the wake. There is no explicit representation of the gust spatial variations.

To illustrate the significance of gust gradients, Figure 30 compares the frequency response at zero airspeed of lateral tip-path-plane tilt to a unit longitudinal gust and to a lateral gust gradient. The magnitude of the gradient input has been normalized by rotor radius such that the gust velocity at the tip is 1 ft/sec. It can be seen that the steady state and low frequency amplitude response to the gust gradient is 13 db or about 4.5 times higher than the response to the uniform gust. Since the thrust vector tilts with the tip-path-plane, it can be inferred that omission of the aerodynamic forcing due to the time variation of the gradient term would result in significant underestimation of the moment disturbance due to turbulence.

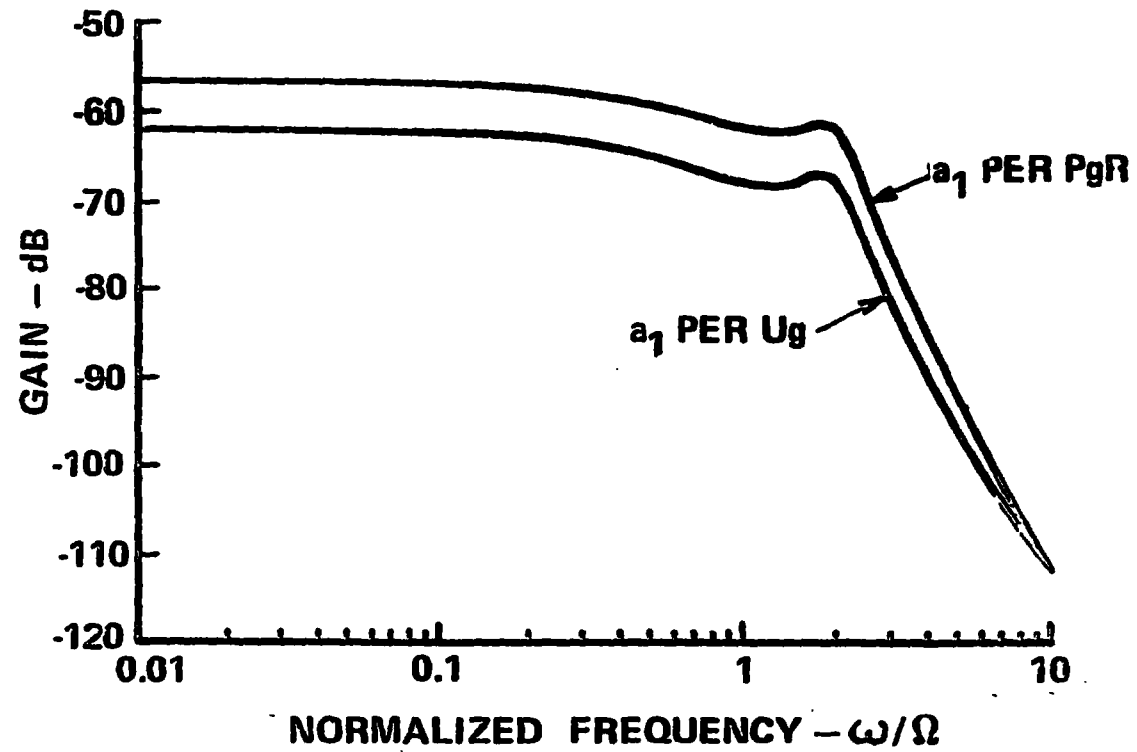

Figure 30 LONGITUDINAL FLAPPING FREQUENCY RESPONSES TO LONGITUDINAL GUST AND LATERAL GRADIENT OF VERTICAL GUST

A proper assessment of the significance of gust gradients requires a comprehensive examination first of the relative magnitudes of the force and moment disturbances due to time varying uniform and first and higher order gusts and the sensitivity of the rotorcraft to these disturbances. The latter question could be addressed analytically using dynamic rotor models such as the tip-path-plane model described in Reference 21. Using the results of these analysis as guidelines, wind tunnel tests could be designed, using multiple multiprobe sensors to measure the time variation of both the three velocity components and the gust gradients as functions of position in the wake of various simulated obstacles.

Although the Operational Capability Classes in the proposed specification treat outside visual cues as either being available or not being available, there is a need to define atmospheric conditions which affect visibility and the operation of vision aid devices. The density of precipitation in the form of rain, snow and fog or the density of particulates such as sea spray, dust, haze and smoke are examples of factors which limit visibility both for human eyes and for vision aid devices. The Operational and Most Severe Environments should be defined for the factors affecting visibility.

The characteristics of terrain contour, vegetation and constructed objects can be of significance to nap of the earth flight, terrain avoidance flight, masking from enemy forces and navigation tasks. Definition or designation of terrain characteristics should be included in the environment descriptions. One approach is to identify actual geographic areas as the terrain model to be used in the design, development and evaluation process.

4.2 REVIEW AND EVALUATION OF FACILITIES

Research facilities identified by Calspan which have potential for rotorcraft flying qualities research or development of related technologies are listed in Table 1. The facilities have been listed in four categories.

- Ground Simulators
- In-Flight Simulators
- Wind Tunnels
- Rotorcraft Mathematical Models

Table 1
FACILITIES FOR DATA GENERATION

GROUND SIMULATORS

1. Vertical Motion Simulator (S.08)
2. Flight Simulator For Advanced Aircraft (S.10)
3. Six DOF Motion Simulator (S.01)
4. Fixed Base Rotorcraft Simulator (S.19)
5. Fixed-Base Chair (CH.06)
6. Martin Marietta Simulator
7. Boeing-Vertol Small Amplitude Simulator
8. Sikorsky Simulation Facility

IN-FLIGHT SIMULATORS

1. NRC Bell 205
2. Ames CH-47
3. X-22A
4. BO 105-S3 Fly by Wire and Variable Stability
5. UH-1 V/Stoland
6. ADOCS UH-60
7. Sikorsky ARTI Test Bed
8. Boeing Vertol ARTI Test Bed
9. Rotor Systems Research Aircraft
10. Navy Test Pilot School CH-46

WIND TUNNELS

1. Boeing-Vertol
2. University of Colorado
3. Calspan

ROTORCRAFT MATHEMATICAL MODELS

1. Airframe Companies
2. Second Generation Helicopter Program
3. ARMCOP

Organizations and individuals responsible for generating flying qualities data for rotorcraft are faced with a dilemma. Simulation of low altitude maneuvering flight taxes the capabilities of ground simulators and questions relating to time delays in both the visual scene and the motion system, limited field of view of visual scenes, fidelity of outside scenes, and limited capacity of motion systems combine to leave a considerable uncertainty concerning the validity of the results of experiments performed on ground simulators. The data presented in Figure 31 from Ref. 10 permit comparison of data from an in-flight experiment (LATHOS) performed in the NT-33A variable stability airplane with data from a replication of that experiment (McLATHOS) performed by McDonnell Aircraft Company in a ground simulator. The two sets of data exhibit gross differences in definition of the combinations of control sensitivity and roll damping which correspond to Level 1 flying qualities. Results of this nature cause doubt concerning the general validity of ground simulator results for flying qualities.

The alternative to the use of ground simulators for flying qualities research is to use in-flight simulators or variable stability aircraft. The dilemma arises because existing in-flight simulators are single string designs and there is a flight safety risk involved in using these flight simulators for aggressive maneuvering at low altitude and near obstacles such as trees or structures. Performing evaluations of new control concepts or failure modes of proposed designs using in-flight simulators carries an element of risk even if the in-flight simulator is assumed to be failure free. This is because the flying qualities of the configuration being evaluated may be Level 3 or worse and there may be a risk that the evaluation pilot will lose control. This situation is normally handled by the safety pilot who disengages the test configuration and assumes active control using an independent control system. This operating procedure has been used successfully in many in-flight simulators and testbeds but when the evaluation task requires aggressive maneuvering in very close proximity to obstacles, the margin of safety is diminished. When using an in-flight simulator, the experimenter has less control over environmental conditions and testing in the more severe environments can raise further concerns for flight safety.

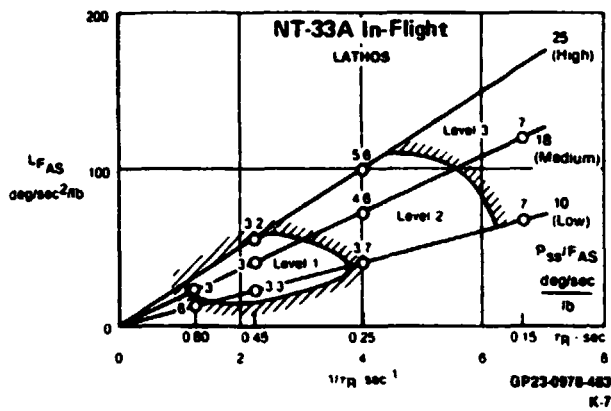
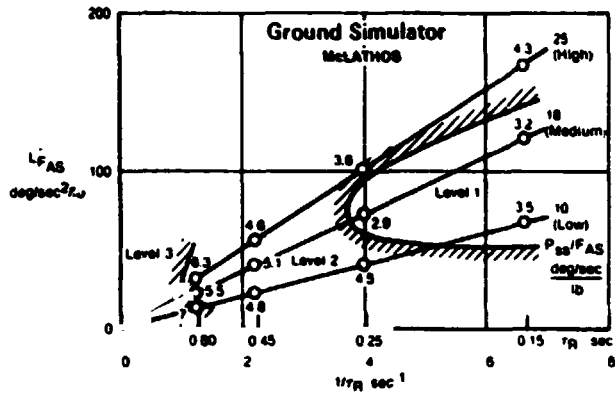

Figure 31 COMPARISON OF McLATHOS AND LATHOS BASELINE CONFIGURATIONS

The challenge to operators of ground simulators is whether or not the experimental results they produce are valid for establishing flying qualities specifications. The data in Figure 31 would indicate that there are cases where the answer is negative. Ground simulator cueing technology is under intensive research and development, however, and there is always anticipation that the next generation of hardware will achieve the elusive goal of providing satisfactory fidelity. There is a continued need for critical examination and validation of ground simulator flying qualities results and it must be recognized that specifications based only on ground simulator data may be misleading.

The major data gaps are in operational capability Classes IV and IVs. Simulation and experimentation for these Operational capability classes requires equipment for navigation, guidance, displays, vision aids, sensors, weapon systems, communications, data management, controllers, pilot-system interfaces, etc. The unavailability of operating hardware suitable for use in flight test or in in-flight simulator experiments can be a problem that inhibits data generation. As was noted above, simulation of flight phases such as nap-of-the-earth maneuvering, air combat, air-ground weapon delivery, ship board landing etc. in ground based facilities requires equipment for motion cueing, visual scene generation-display, and vision-aid image simulation and display. To date, the cueing fidelity obtainable with this equipment has left doubt concerning the validity of flying qualities data generated in experiments performed on ground simulator facilities.

Cockpit procedures, equipment arrangement, design of pilot-equipment interface controls and automation of functions are examples of technical areas that can be developed successfully by using ground based simulators. The acceptability of control laws, primary controllers and information displays for pilot-in-the-loop control during critical Flight Phases should be determined from in-flight simulation and/or flight test. Flight testing may be performed in surrogate aircraft, i.e. test bed or prototype aircraft which are used for concept demonstration. An example is the Boeing Model 347 testbed which was used to develop and demonstrate the general arrangement, flight control system, controller, and the load controlling crewman's crew station planned for the Heavy Lift Helicopter Program.

Ground Simulators

Currently the ground simulator with the highest potential for generating flying qualities data for military rotorcraft is the Vertical Motion Simulator (VMS) S.08 facility located at NASA Ames Research Center. This facility is currently being modified for the U.S. Army to include a special motion generator and advanced cab/visual system. The Army is acquiring a computer generated image system for the VMS for use in NOE simulation. The VMS facility is illustrated in Figure 32.

Boeing Vertol has developed a ground simulator which includes a small amplitude "nudge" motion system and a multi window television display system. The image is derived from a terrain model board through a special optical probe which permits display of the view through multiple windows. Results from this simulator have compared favorably with results from the VMS for simulations performed during the Advanced Digital Optical Control System Program (ADOCS).

In-Flight Simulators

A total of ten flight vehicles are listed in Table 1 which have some capability for flying qualities research. Of this group, the NRC 205 and the X-22A variable stability aircraft are the most mature and readily available for flying qualities research. A detail description of the X-22A facility is contained in Appendix C. The Ames CH-47 is currently being outfitted with a variable feel system and a model following system which will provide in-flight simulation capability. The Federal Republic of Germany is developing a fly by wire B0 105-S3 which will be equipped with a model following system in the near future. The Army VSTOLAND UH-1 helicopter has variable stability and variable display capability but is not equipped with a variable feel system. The U.S. Navy Test Pilot school operates a CH-46 which has limited capability to vary augmentation and control system dynamics.

There are four vehicles included in the list which are not exactly variable stability or in-flight simulators but they will exhibit capability for in-flight testing and research. These are the Army UH-60 ADOCS testbed, the rotor systems research aircraft and two testbeds that are planned by Sikorsky and Boeing Vertol as part of their Research and Development efforts in support of the ARTI and LHX programs. Sikorsky is modifying an S-76 helicopter to include a separate evaluation cockpit built onto the aircraft ahead of the existing cockpits. Boeing Vertol is also planning to develop a

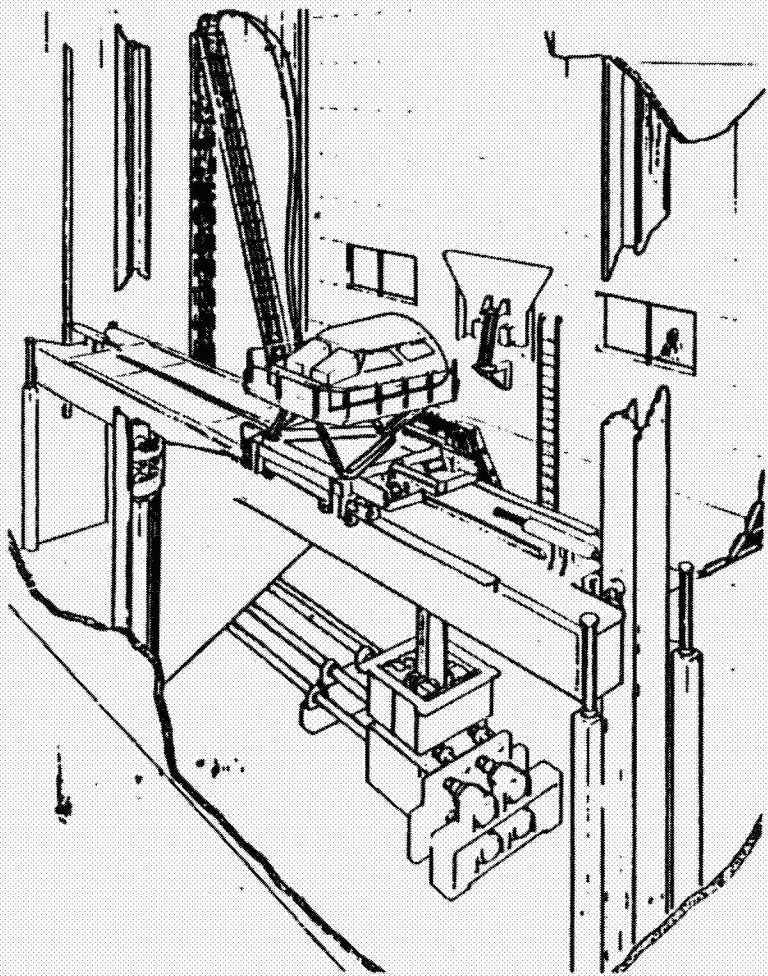

EXISTING VERTICAL MOTION SIMULATOR

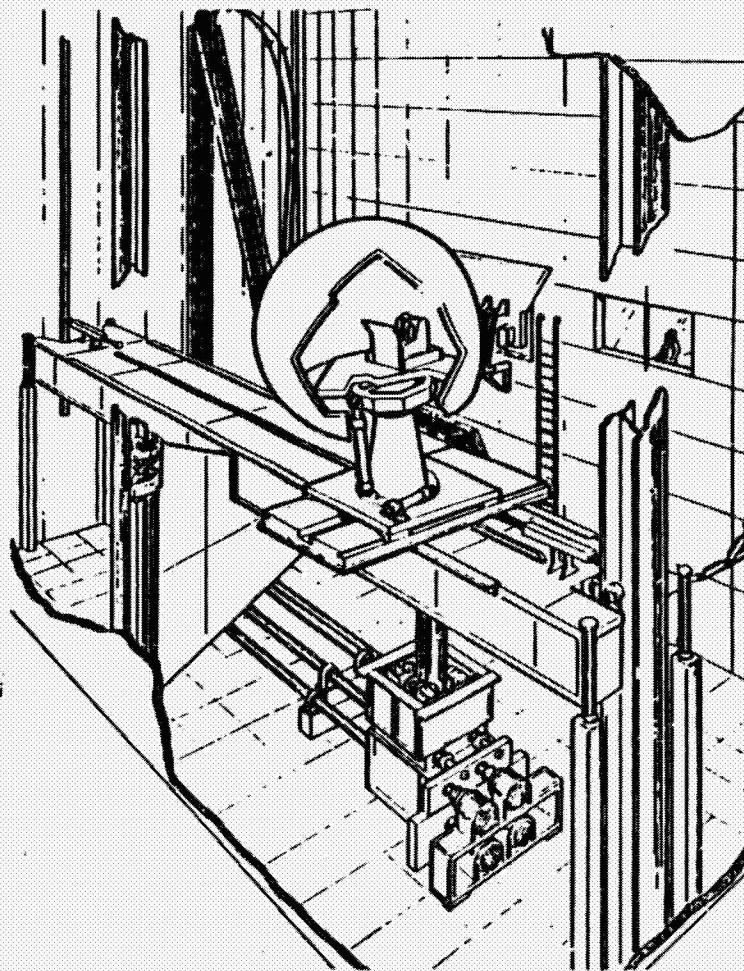

FUTURE VMS WITH INTEGRATED RSMG AND INTERCHANGEABLE ADVANCED ROTORCRAFT CAB/VISUAL SYSTEM

ORIGINAL PAGE IS
OF POOR QUALITY

Figure 32 THE VERTICAL MOTION SIMULATOR (VMS) RSIS PROJECT OVERVIEW

testbed, probably using a BO-105 or an Augusta A-109 helicopter. The Sikorsky and Boeing test beds will likely be used to test and develop ideas and hardware for single pilot LHX missions. This will likely include vision aids, flight control concepts, coupled modes and the cockpit hardware with which the pilot must interface. The objective will be to determine the feasibility of a single pilot design for LHX.

Wind Tunnels

Extension and improvement of models to describe airwakes behind ships, trees, building, etc. may require additional data obtained from tests of models in wind tunnels. The low speed facilities located at Boeing Vertol, University of Colorado and at Calspan Corporation in Buffalo, New York are considered to be well suited for this purpose.

Rotorcraft Mathematical Models

Rotorcraft mathematical models will continue to play an important role in ground simulation, parameter identification of flight test data and stability and control analysis and flight control system design. Since rotorcraft dynamic models tend to be high order and non-linear, it is usually necessary to make many simplifying assumptions in the development of mathematical models, particularly for real time simulation applications. Hansen of NASA Ames (References 22 and 23) has examined this issue from the standpoint of the significance of rotor flapping degrees of freedom to the linearized six degree of freedom to the linearized six degree of freedom rigid body motions of a helicopter. The same rotorcraft models were employed by Calspan in this program to examine the pitch-roll coupling question. These efforts suggest that rotor flap dynamics have a strong influence both on the commanded responses and on the cross-axis coupled responses. For the primary commanded responses, the dominant affect appears to be an effective time delay, which is a function of the natural frequency of the flap regressive mode of the rotor (Figure 33). The effect on the coupled responses is more complex in that the shape of the responses are considerably different for times of the order of one second as indicated in Figure 34.

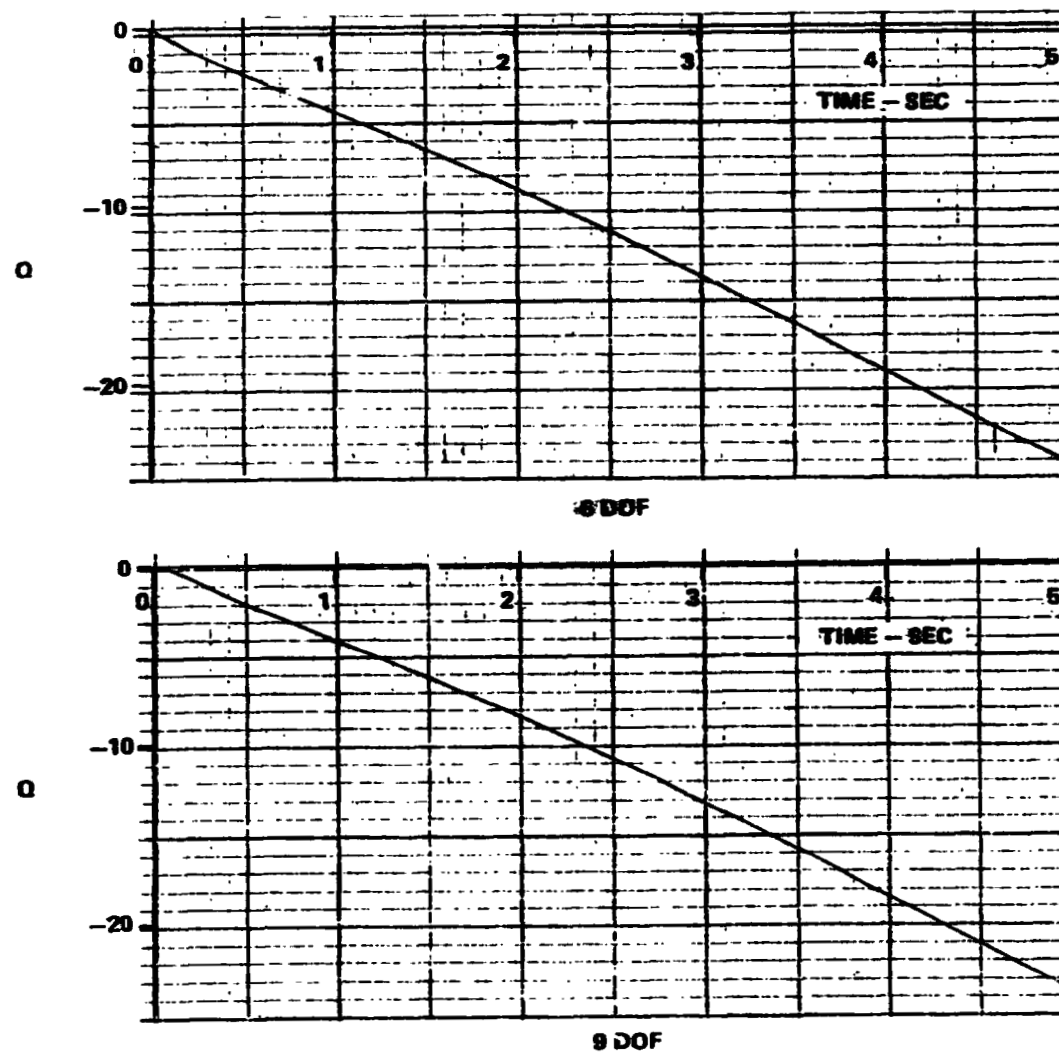

Figure 33 Q RESPONSE TO B_{1S} STEP (CH-53, 100)

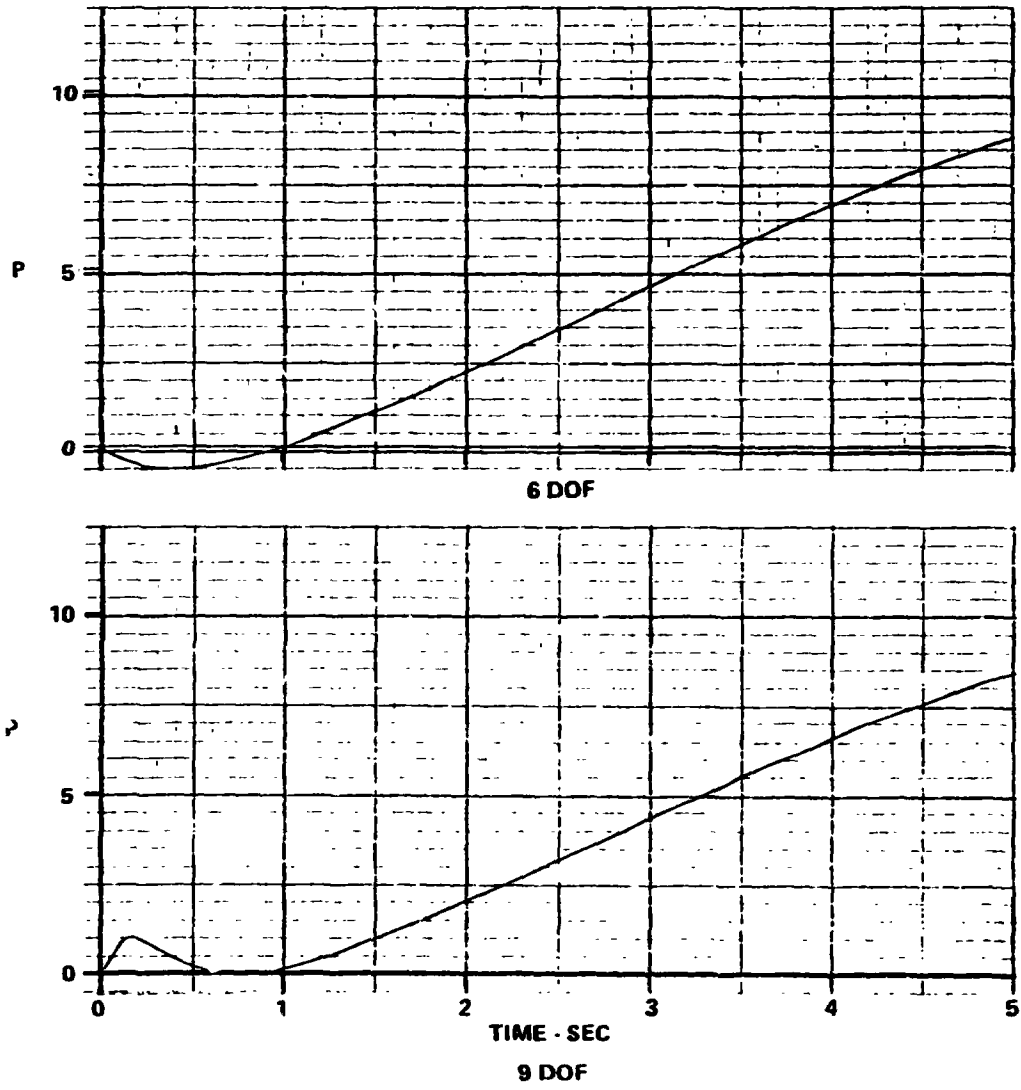

Figure 34 P RESPONSE TO B_{1s} STEP (CH-53, 100 KT)

Other studies (References 18, 19 and 24) have indicated that coupling of rotor angular degrees of freedom with the vertical and lateral-directional degrees of freedom can also modify the dynamics which would be predicted by six degree of freedom models.

There is a need to continue the development validation of lower order rotorcraft mathematical models for simulation and analysis. These efforts will require correlation of airframe company dynamic models such as C-81, Genhel etc., with lower order models (e.g. ARMCOP) and flight test data.

4.3 OUTLINE OF EXPERIMENTS TO GENERATE NEW DATA

4.3.1 AGARD FMP Subcommittee 04

That there are gaps in the knowledge required for the definition of satisfactory flying qualities for future military aircraft has been recognized by the AGARD Flight Mechanics Panel. The panel concluded, in 1982, that the research needed to develop the missing information is extensive and would strain the resources of any one nation. In the fall of 1982, the FMP established Subcommittee 04 for the purpose of accelerating the process of production and dissemination of the required data through a deliberate program of encouraging cooperative research and information sharing among the participating AGARD countries.

Subcommittee 04 prepared questionnaires which were distributed to potential participants to determine information in the following categories.

- Flying qualities research completed but not yet published
- Flying qualities research in progress
- Flying qualities research needs

The responses to these questionnaires were assembled in Reference 11 which was distributed to each participating organization.

4.3.2 Calspan Recommendations

This section contains suggestions for flying qualities experiments, technology developments and facility improvements which Calspan recommends the government consider when planning future research and development activities.

General

Broadly stated, the recommendation is to use the facilities identified in Section 4.2 to attack the critical gaps identified in Section 4.1.

In general, ground simulators are considered most valid for developing cockpit procedures, equipment arrangements, design of pilot-equipment interface controls, for evaluation of and automation of functions including higher level of augmentation such as attitude stabilization and automatic hold modes. In-flight simulators are considered most valid for evaluating the acceptability of control laws, primary controllers, information displays and vision aids for pilot-in-the-loop control during critical Flight Phases. Flight test in testbed or prototype aircraft is appropriate for demonstrating an operational capability. Testbeds are particularly applicable when subsystems are being integrated and performance of the integrated system in the operational environment is of concern.

Existing in-flight simulators were developed with emphasis on variable stability and variable feel capability. The evaluation pilot's station has usually been an adaptation of one station of the existing dual cockpit. The capability for altering the cockpit arrangement is somewhat limited in each vehicle and installation of electronic information displays and vision aids must be done within space and location constraints of the existing cockpit in each case. From certain aspects, in-flight simulators are not simulators but rather they are test vehicles with programmable or variable characteristics. For example, the X-22A has an operational head-up-display, microwave guidance system, prototype precision distance measuring equipment, radar altimeter, low range airspeed system and other sensor hardware. In the ideal application of an

in-flight simulator, the evaluation pilot would perform the operational tasks associated with the Flight Phase under consideration. Practical considerations, however, may prohibit actually performing the operational tasks and it is necessary to base evaluation comments and ratings on surrogate evaluation tasks. For example, a recent program, Ref. 13, used the X-22A to evaluate the suitability of several augmentation concepts for shipboard landing. Because it was not practical to take the X-22A to an actual ship, a surrogate task was devised using the head-up-display. The surrogate task was believed to include the significant or essential elements involved in maneuvering to land on a small landing platform with time limited opportunities for performing the task.

Simulator Validation

Experimental results both from ground simulators and in-flight simulators can be subject to question because of cue fidelity or task fidelity; therefore, there is a continuing need to perform experiments which permit comparison of results. Hopefully, in the long run it will be possible to define when a given simulator can be used with confidence in the validity of the results. The ADOCS program presents an opportunity to make comparisons of results from various ground simulators, in-flight simulators and eventually from the testbed UH-60 helicopter. The ground simulation tests have been performed in both the Boeing nudge simulator and in the large-amplitude-motion NASA VMS simulator. It is recommended that a number of the control system, controller and display configurations from the ADOCS program be included in in-flight simulator programs using one or more in-flight simulator i.e. the NRC 205, NASA CH-47, or Navy X-22A. The in-flight simulators will each require addition of equipment to permit replicating the ADOCS evaluation configurations and/or tasks. For example, the CH-47 and X-22A would require installation of a four axis stick controller. The CH-47 and NRC 205 would require installation of head up displays and all aircraft would require installation of equipment for simulating night vision aids. The X-22A has the capability to measure space position, orientation and the inertial velocity components with high precision which would facilitate display of target location and provide signals for use in control system augmentation and stabilization modes.

Effort should be devoted to the development of detail dynamic models of a number of rotorcraft with different rotor configurations and hub designs. These models should be checked for engineering fidelity through comparison with flight measured responses and then used in real time piloted simulations to compare pilot evaluation results obtained from the simulator with flight test results. In performing such comparisons it will be necessary to tightly define evaluation tasks, performance standards and environmental conditions. Quantitative measures of task performance, pilot control actions and control strategy should be taken in the simulator and in the flight vehicle. Assuming adequate engineering fidelity can be achieved, this type of piloted simulator and flight test comparison would provide a background of data to permit estimation of simulator bias and possibly identify changes in pilot control strategy induced by the simulator cue distortions.

Dynamic Response to Control and Stabilization

This area of research is potentially very large because there are many Flight Phases to consider and many flight control concepts and mechanization choices available to the designer. It is recommended that emphasis be placed on the more demanding Flight Phases associated with the Hover and Low Speed Flight Region and the lower speed portion of the Forward Flight Region. Flight phases associated with the projected LHX mission (Figure 1), air-air combat, shipboard landing, slung load handling, mine countermeasures, etc. should be given priority. High fidelity simulation of some of these Flight phases may be beyond the capabilities of existing simulator facilities and it may be necessary to either extend the capabilities of the facility or to perform evaluations using surrogate tasks that are within the simulator capability.

The general approach used in the ADOCS research program for identifying candidate control/stabilization concepts for each Flight Phase is recommended, however, a range of dynamic parameters for each concept should be evaluated in order to permit writing specification requirements.

It should be noted that several of the Flight Phases identified above involve complex dynamic systems and the piloting task requires simultaneous control of many degrees of freedom within constraints that are system specific. As was noted in Section 3.3, mine sweeping is an example of a complex task which involves many constraints imposed by the slewing dynamic characteristics, boom angle limits and by the task performance standard. It does not appear feasible to derive valid flying quality design

criteria for this Flight Phase through generic control system research. It is likely that a focused design effort would be necessary which accounted for the specific task performance standard and the various operational constraints and performance limits of the sled and the helicopter.

High fidelity simulation, i.e. an in-flight simulator, of the mine counter measures Flight Phase would require a 6 degree-of-freedom model following simulator with capability to trim with a nose down attitude independent of forward speed. Currently there is no rotorcraft in-flight simulator with these capabilities.

Recent interest in using rotorcraft for air combat has presented new challenges to the authors of flying qualities specifications, the simulation community and to the military units responsible for development of tactics and training. Efforts by all of these disciplines should be encouraged to develop and validate math models for maneuvering rotorcraft, to develop simulator technology which will permit air combat simulation between helicopters at low altitude and to develop operational rules of engagement for helicopters. The experience and data being accumulated at NATC through flying combat engagements between various helicopter types should be reviewed and extended if the initial results are encouraging.

Research efforts to improve capability to operate rotorcraft from small non-aviation ships under adverse weather conditions should be continued. The research program planned under the NAVTOLAND project to achieve the interim goal of a capability to operate in sea state 5 with visibility limited to 700 ft and to operate into small advanced bases should be pursued using the VMS and the unique capabilities of the Navy X-22A in-flight simulator.

Single Pilot LHX

Development of the single pilot LHX concept for the Army will be a major focus of the helicopter industry and the supporting avionic and flight control specialists for several years. Of primary concern is the capability of a single pilot to handle the workload associated with the functional requirements listed in Figure 1 of Section 3.3. Cockpit mock ups and ground simulators should be used to develop the equipment

arrangement and interface between the pilot and the controls and displays for the avionic equipment. Ground simulators should be used to explore the pilot's capability to perform the LHX mission scenario. In-flight simulation of high workload mission segments should be performed to introduce the additional stress associated with actual flight situations. The Navy X-22A in-flight simulator has many capabilities well suited for use in this application but would require installation of additional equipment and simulated equipment. Examples are night vision aids and simulated threat warning equipment.

Many subsystems must be integrated to achieve the operational capability being specified for the LHX. It is highly recommended that testbed flight vehicles be utilized to develop this capability and to demonstrate that a viable design has been achieved.

The candidate list of LHX flight control functions contained in Figure 2 indicates that the Army planners are assuming that the rotorcraft will have to be highly augmented including numerous hold modes and modes where the flight control system is coupled to navigation, guidance, target acquisition and weapon subsystems. If the candidate list of functions in Figure 2 is accepted as a valid list of requirements, then there is a need for research and simulation to determine the appropriate dynamic characteristics for each mode and to develop an interface through which the pilot can easily call up and/or recognize a given mode and transfer from one mode to another without worry over initial conditions or transient responses. Because the LHX will be required to operate at low altitude near obstacles it will be necessary to define limits for transient motions (related to mode switching and failures) more in terms of vehicle displacements rather than in terms of accelerations, rates or attitude excursions.

One could challenge the need for the degree of augmentation and automation that the Army has suggested in Figure 2. In this case, there would be a requirement for research and simulation to identify what level of augmentation and automation that the pilot actually requires. It should be noted that many sensors will be required to permit performing the functional requirements of LHX and use of these sensors in the flight control system may not have a large effect on the vehicle total cost. The primary cost increase would probably be in computer capacity and software development although use of sensors in the flight control system may require redundancy in that sensor system over and above what would be acceptable for functional capability. The point is that since the sensors are going to be available anyway, the flight control

designer should make full use of them to achieve the maximum capability and workload relief rather than searching for a trade off between increased workload and decreased augmentation and automation. This argument assumes that the systems management workload does not increase unduly when the numerous hold and coupled modes are introduced.

Methods for evaluating and measuring workload and the susceptibility to error should be developed for application in the systematic design of the single pilot LHX cockpit.

Development of Criteria to Limit Coupling

Calspan has proposed requirements in the Dratt Specification, Paragraph 3.8.9 of Appendix A, which are intended to limit angular rate coupling in response to cyclic commands. The quantitative limits specified in this requirement are based on ground simulator data, from Ref. 14, which exhibits much scatter and lack of agreement between the evaluation pilots involved in the experiment. It is recommended that further experiments be performed using in-flight simulators and evaluation tasks which require both rapid maneuvering and precise flight path control and/or target tracking.

Criteria for Most Severe Environments

The discussion in Section 2.4 of Appendix B recognizes that achieving Level 3 flying qualities (Level 2 for Landing) in the most severe environment may require higher levels of augmentation than is necessary to achieve Level 1 flying qualities in the Operational Environment. Flying qualities research should be performed involving Most Severe Environmental conditions to develop the data needed to support quantitative requirements for Level 3 (Level 2 for Landing). Of primary interest are wind, turbulence, wind shears and air wakes. This is a difficult technical area because simulation requires accurate modelling of the environment, a valid capability to compute rotorcraft responses to the air disturbance and a simulator which provides valid cues to the evaluation pilot. Current capabilities in all of these areas leave some doubt concerning the validity of ground simulator results. In-flight simulators are also limited in their capability to simulate the effects of air disturbances. If a model following method is used in the

in-flight simulator, then the same concerns over modelling the disturbance and the rotorcraft responses will exist as in the case of the ground simulator. Accurate simulation of computed model motions would require a 6 DOF simulation capability which is not currently available in any rotorcraft in-flight simulator. Test of in-flight simulators or other flight vehicles in actual Severe Environments is a possibility, however, there is usually little control over such environments. In addition, the response to the air disturbance may be influenced by the aerodynamic characteristics of the in-flight simulator host-airframe which may bias the results. For example, the X-22A has a fairly large value of sideforce due to side velocity which biases the cross wind behavior of the X-22A.

Improved capability to model air disturbances and their effects on rotorcraft motions and their effects on sensors used in augmentation systems is needed. Improved capability to simulate rotorcraft responses to severe air disturbances is also necessary both for ground simulators and in-flight simulators. In the meantime, tentative results should be generated using existing simulation facilities, flight test and operational experience.

Inner Loop and Higher Derivative Limits

Identification of limits of this type should be part of research efforts to define dynamic response to control. Care should be taken to properly represent the linear acceleration at the crew stations when performing experiments, especially for large vehicles. Proper simulation of the accelerations at the crew station can place high demands on motion systems for ground simulators and require independent force controls for in-flight simulators.

Vision Aids and Information Displays

Research and development of imaging sensors, signal processing and imaging displays should be encouraged and sponsored. Research to determine the content and format of information displays for specific flight phases should be continued using ground simulators, in-flight simulators and test vehicles such as the AHIP prototype.

REFERENCES

1. "Military Specification Helicopter Flying and Ground Handling Qualities; General Requirements For." MIL-H-8501A , 7 September 1961.
2. Green, D. "Military Specification Helicopter Flying and Ground Handling Qualities: General Requirements For" MIL-H-8501B (Proposed) Working Draft, 24 May 1972.
3. Green, D. "First Revision to Background Information and Users Guide for MIL-H-8501B (Proposed) - Military Specification - Helicopter Flying and Ground Handling Qualities; General Requirements For." Pacer Systems Inc., 30 May 1973.
4. Anon. "System Specification for Utility Tactical Transport Aircraft System, Flying and Ground Handling Qualities Specification." Appendix I, AMC-SS-2222-10000B 1 August 1975.
5. Anon. "Flying and Ground Handling Qualities Specification Advanced Attack Helicopter" Appendix I, AMC-SS-AAH-H10000A, 15 October 1976.
6. Anon. "Military Specification, Flying Qualities of Piloted V/STOL Aircraft" MIL-F-83300, 31 December 1970.
7. Anon. "Military Specification, Flying Qualities of Piloted Airplanes" MIL-F-8785B (ASG), 16 Sept. 1974.
8. Anon. "Military Specification, Flying Qualities of Piloted Airplanes" MIL-F-8785C, 5 November 1980.
9. Hoh, R. et al. "Proposed MIL STANDARD and Handbook - Flying Qualities of Air Vehicles" AFWAL-TR-82-3081, Volume 1 Proposed MIL Standard; Volume 2 Proposed MIL Handbook.
10. Wood, J. R. "Comparison of Fixed-Base and In-Flight Simulation Results for Lateral Higher Order Systems", McDonnell Aircraft Co.
11. Anon. "Improved Flying Qualities Through Cooperation"; AGARD FMP Subcommittee 04. 1983.
12. Anon. "Expanded Addendum to Program Plan, Schedules and Work Statements". March 1978. P.E. 63203N Project W0570. NAVTOLAND Project Office.
13. Radford, R.C., D. Andrisani II, J. Beilman "An Experimental Investigation of VTOL Flying Qualities Requirements for Shipboard Landings" NADL-77318-60; August 1981.
14. Chen, R.T.N.; P. Talbot "An Exploratory Investigation of the Effects of Large Variations in Rotor System Dynamics Design Parameters on Helicopter Handling Characteristics in Nap-of-the-Earth Flight", American Helicopter Society Journal Vol. 24, No. 3, July 1978.

15. Neal, T.P. and Smith, R.E., "An In-Flight Investigation to Develop Control System Design Criteria for Fighter Airplanes," AF FDL-TR-70-74, December 1970.
16. Berthe, C.J., "In-Flight Investigation of Pitch Rate Control Systems for the Final Approach and Flared Landing Task". Calspan Report to be published.
17. Landis, K.H., Aiken, E.W., "An Assessment of Various Side Stick Controller/Stability and Control Augmentation Systems for Night Nap-of-Earth Flight Using Piloted Simulation," NASA CP-2219, April 1982.
18. Corliss, L.D., "A Helicopter Handling Qualities Study of the Effects of Engine Response Characteristics, Height-Control Dynamics, and excess Power on Nap-Of-The-Earth Operations', NASA CP-2219, April 1982.
19. Corliss, L.D., Blanken, C.L., Nelson, K., "Effects of Rotor Inertia and RPM Control on Helicopter Handling Qualities", Paper AIAA-83-2070, AIAA Atmospheric Flight Mechanics Conference, August, 1983.
20. Radford, R.C., Schelhorn, A.E. et al, "Evaluation of the XV-15 Tilt Rotor Aircraft for Flying Qualities Research Application", NASA CR 137828, April 1976.
21. Chen, R.T.N., "A Simplified Rotor System Mathematical Model for Piloted Flight Dynamics Simulation", NASA TM-78575, May 1979.
22. Hansen, R.S. (NASA); "On Approximating Higher-Order Rotor Dynamics in Helicopter Stability -Derivative Models"; AIAA-83-2088; August 15-17, 1983.
23. Hansen, R.S. (NASA); "Toward a Better Understanding of Helicopter Stability Derivatives"; U.S. Army Aeromechanics Laboratory, Moffett Field, Calif. 94035; August 31-September 3, 1982.
24. Kuczynski, W.A. et al.; "The Influence of Engine/Fuel Control Design on Helicopter Dynamics and Handling Qualities" paper presented at 35th Annual national Forum of the American Helicopter Society, May 1979.

APPENDIX A

DRAFT SPECIFICATION PROPOSED FOR MIL-H-8501A

MIL-H-8501A
TM No. 19
5 April 1983
Revision #1 - August 1983
Revision #2 - October 1983
Revision #3 - November 1983

**DRAFT SPECIFICATION STRUCTURE
PROPOSED FOR MIL-H-8501A REVISION**

Calspan Contract No. NAS2-11303

Prepared by:

**C.R. Chalk
R.C. Radford**

TABLE OF CONTENTS

<u>Section</u>		<u>Page</u>
1	SCOPE AND CLASSIFICATIONS	A-7
	1.1 APPLICABILITY	A-7
	1.2 OPERATIONAL MISSIONS AND FLIGHT PHASES	A-8
	1.3 FLIGHT REGIONS	A-9
	1.3.1 Hover and Low Speed	A-9
	1.3.2 Forward Flight	A-9
	1.3.3 Accelerating and Decelerating Transition	A-9
	1.3.4 Autorotation	A-9
	1.3.5 Takeoff and Landing	A-9
	1.3.6 Ground Handling	A-9
	1.4 CLASSIFICATION OF REQUIRED OPERATIONAL CAPABILITY	A-10
	1.5 CATEGORIZATION OF FLIGHT PHASES	A-11
	1.6 LEVELS OF FLYING QUALITIES	A-12
2	DEFINITIONS AND APPLICABLE DOCUMENTS	A-13
	2.1 DEFINITION OF THE ROTORCRAFT	A-13
	2.1.1 Loadings	A-13
	2.1.2 Moments of Inertia and Products of Inertia	A-13
	2.1.3 External Stores	A-13
	2.1.4 Configurations	A-14
	2.1.5 State of the Rotorcraft	A-14
	2.1.5.1 Rotorcraft Normal States	A-14
	2.1.5.2 Rotorcraft Failure States	A-15
	2.1.5.3 Rotorcraft Specific Failure States	A-15
	2.1.5.4 Rotorcraft Special Failure States	A-15
	2.2 DEFINITION OF FLIGHT ENVELOPES	A-16
	2.2.1 Operational Flight Envelopes	A-16
	2.2.2 Service Flight Envelopes	A-16
	2.2.3 Operating Limitations	A-16
	2.3 DEFINITION OF THE ENVIRONMENT	A-17
	2.3.1 Operational Environment	A-17
	2.3.2 Most Severe Environment	A-17
	2.4 DEFINITION OF CONDITIONS FOR WHICH DEGRADED FLYING QUALITIES ARE PERMITTED	A-18
	2.4.1 Applications of Levels	A-18
	2.4.2 Requirements for Airplane Normal States	A-18
	2.4.3 Requirements for Airplane Failure States	A-19
	2.4.4 Explanatory Notes Concerning Application of Levels	A-20
	2.4.4.1 Conceptual Diagrams of the Design Evaluation Process	A-20
	2.4.4.2 Theoretical Compliance	A-20
	2.4.4.3 Definitions of Level Regions	A-21
	2.4.4.4 Computational Assumptions	A-24
	2.5 APPLICABLE DOCUMENTS	A-25
3	FLYING QUALITIES REQUIREMENTS FOR CLASS I REQUIRED OPERATIONAL CAPABILITY	A-26
	3.1 HOVER AND LOW SPEED	A-26
	3.1.1 Equilibrium Control Gradients wth Airspeed	A-26
	3.1.2 Dynamic Stability Requirements	A-27

SectionPage

3

3.1.2.1	Effective Time Delay in Angular Rate and Rate of Climb	A-28
3.1.2.2	Angular Rate Response Time	A-29
3.1.2.3	Rate of Climb Response Time	A-30
3.1.2.4	Vertical Oscillations	A-30
3.1.2.5	Rotor RPM Variation	A-30
3.1.3	Precision Load Placement	A-30
3.1.4	Target Tracking	A-31
3.1.5	Control for Trim	A-31
3.1.6	Control Power	A-31
3.1.6.1	Alternate Requirements	A-32
3.1.6.2	Height Control Power	A-32
3.1.7	Control-Response Sensitivity	A-32
3.1.7.1	Collective Control-Response Ratio	A-33
3.1.8	Trim Variation with Power or Collective	A-33
3.1.9	Translational Flight in Ground Effect	A-34
3.1.10	Response to Horizontal Wind Gust	A-34
3.1.11	Longitudinal Control Force in Lateral Translational Flight	A-34
3.2	FORWARD FLIGHT	A-34
3.2.1	Longitudinal Equilibrium Control Gradients with Speed	A-34
3.2.2	Longitudinal Dynamic Requirements	A-35
3.2.2.1	Longitudinal Dynamic Stability	A-35
3.2.2.2	Longitudinal Dynamic Response	A-36
3.2.2.3	Target Tracking	A-37
3.2.3	Longitudinal Control in Unaccelerated Flight	A-38
3.2.4	Longitudinal Control Effectiveness in Maneuvering Flight	A-38
3.2.5	Longitudinal Control Gradients in Maneuvering Flight	A-38
3.2.6	Longitudinal Control Forces in Dives	A-39
3.2.7	Longitudinal Control in Sideslips	A-39
3.2.8	Longitudinal Control Force Variations Due to Gusts and and Collective Inputs	A-40
3.2.9	Lateral-directional Characteristics in Steady Sideslips	A-40
3.2.9.1	Yawing Moments in Steady Sideslips	A-40
3.2.9.2	Bank Angle in Steady Sideslips	A-41
3.2.9.3	Rolling Moments in Steady Sideslips	A-41
3.2.9.4	Lateral Control Required in Steady Sideslips	A-41
3.2.10	Lateral-directional Dynamic Stability	A-41
3.2.10.1	Effective time delay & response time	A-43
3.2.11	Target Tracking	A-43
3.2.12	Lateral-directional Control in Unaccelerated Flight	A-44
3.2.13	Lateral Control Effectiveness in Maneuvering Flight	A-44
3.2.14	Directional Control Effectiveness - Steady Sideslips	A-44
3.2.15	Directional Control Effectiveness-Yaw Attitude Change	A-45
3.2.16	Linearity of Response to Lateral-directional Controllers	A-45
3.2.17	Lateral-directional Control Forces	A-46
3.2.18	Lateral Control Sensitivity	A-46
3.2.19	Lateral-directional Trim Variation with Power or Collective	A-46

<u>Section</u>		<u>Page</u>
3	3.2.20 Directional Control with Asymmetric Loading	A-47
	3.2.21 Control of Sideslip in Rolls	A-47
	3.2.22 Turn Coordination	A-47
	3.2.23 Rudder Pedal Induced Roll	A-47
	3.2.24 Turns Without Use of Rudder Pedal	A-48
	3.2.25 Bank Angle and Roll Rate Oscillations	A-48
	3.2.26 Sideslip Excursions	A-48
3.3	ACCELERATING AND DECELERATING TRANSITIONS	A-48
	3.3.1 Accelerating and Decelerating Capability	A-48
	3.3.2 Operating Restrictions	A-51
	3.3.3 Flexibility of Operation	A-51
	3.3.4 Control Manipulations Required for Accelerations/Decelerations	A-51
	3.3.5 Control Margins	A-51
	3.3.6 Control Displacements and Forces	A-51
	3.3.7 Control Force Variations	A-52
3.4	AUTOROTATION	A-52
	3.4.1 Autorotation Capability	A-52
	3.4.1.1 Multiengine Rotorcraft	A-52
	3.4.1.2 Failure of Engine Developing Highest Power	A-52
	3.4.1.3 Pilot Reaction Delay	A-53
	3.4.1.4 Attitude Change from Initial Conditions	A-53
	3.4.1.5 Altitude Loss	A-53
	3.4.1.6 Rotor RPM Drop	A-53
	3.4.1.7 Control Margins	A-53
	3.4.1.8 Control Force Variations	A-54
	3.4.1.9 Rotor Speed Control in Autorotation	A-54
	3.4.1.10 Dynamic Stability in Steady Autorotation	A-54
3.5	GROUND HANDLING, TAKEOFF & LANDING	A-54
	3.5.1 Starting and Stopping Rotor	A-54
	3.5.2 Holding Ground Position	A-54
	3.5.3 Holding Deck Position on Moving Ship	A-55
	3.5.4 Ground Handling	A-55
	3.5.5 Directional Control on Ground	A-55
	3.5.5.1 Maintain Straight Path	A-55
	3.5.5.2 Turns Through 360°	A-55
	3.5.6 Vertical Takeoff and Landing Capability	A-55
	3.5.7 Running Takeoffs	A-55
	3.5.8 Landing from Autorotation	A-56
	3.5.9 Control Effectiveness in Takeoff	A-56
	3.5.10 Control Effectiveness in Landing	A-56
	3.5.11 Control Force Limits in Takeoff & Landing	A-56
3.6	FLIGHT CONTROL SYSTEM	A-56
	3.6.1 Controller Freeplay and Dead Zone	A-56
	3.6.2 Control Centering and Breakout Forces	A-57
	3.6.3 Controller Force - Displacement Gradients in the Hover and Low Speed Flight Region	A-57
	3.6.4 Adjustment of Controllers	A-58
	3.6.5 Rate of Control Displacement	A-58
	3.6.6 Mechanical Cross-Coupling	A-58
	3.6.7 Dynamic Characteristics	A-58
	3.6.8 Control System Damping	A-59

<u>Section</u>		<u>Page</u>
3	3.6.9 Augmentation Systems	A-59
	3.6.10 Performance of Augmentation Systems	A-59
	3.6.11 Flight Control System Failures	A-59
	3.6.12 Control Force to Suppress Transients	A-60
	3.6.13 Transients and Trim Changes	A-60
	3.6.14 Transfer to Alternate Control Modes	A-60
	3.6.15 Trim System	A-60
	3.6.16 Rate of Trim Operation	A-61
	3.6.17 Trim System Irreversibility	A-61
	3.6.18 Collective Irreversibility	A-61
3.7	SPECIFIC FAILURES	A-61
	3.7.1 General	A-61
	3.7.2 Failure Warnings	A-62
	3.7.3 Loss of Tail Rotor Thrust	A-62
	3.7.4 Engine and Primary Electrical Failure	A-62
3.8	MISCELLANEOUS REQUIREMENTS	A-62
	3.8.1 Approach to Dangerous Flight Conditions	A-62
	3.8.2 Warning and Indication	A-62
	3.8.3 Prevention of Dangerous Conditions	A-62
	3.8.4 Pilot Induced Oscillations	A-63
	3.8.5 Residual Oscillations	A-63
	3.8.6 Buffet	A-63
	3.8.7 Release of Stores	A-63
	3.8.8 Effects of Armament Delivery and Special Equipment	A-64
	3.8.9 Cross-coupled Effects	A-64
	3.8.10 Gyroscopic Effects	A-64
	3.8.11 Inertial and Aerodynamic Cross-Coupling	A-65
	3.8.12 Vibration Characteristics	A-65
3.9	ENVIRONMENTAL CONDITIONS	A-65
	3.9.1 Continuous Turbulent Models	A-65
	3.9.1.1 Scale lengths	A-66
	3.9.1.2 RMS intensities	A-66
	3.9.1.3 Application of the disturbance model in analyses	A-67
	3.9.2 Discrete Gust Model	A-68
	3.9.2.1 Gust lengths	A-69
	3.9.2.2 Gust magnitudes	A-69
	3.9.3 Mean Wind Model	A-69
	3.9.4 Tree-line Wake	A-71
	3.9.5 Ship Airwake Models	A-73
	3.9.6 Rainfall Model	A-73
	3.9.7 Atmospheric temperature, pressure and density	A-73
	3.9.8 Ambient light	A-74
	3.9.9 Surface slope-takeoff/landing	A-74
	3.9.10 Ship motion models	A-74
	3.9.11 Flight deck environment	A-74

I SCOPE AND CLASSIFICATIONS

I.1 APPLICABILITY

This specification contains the requirements for the flying and ground handling qualities of U.S. military rotorcraft.

1.2 OPERATIONAL MISSIONS AND FLIGHT PHASES

The procuring activity will specify the operational missions to be considered by the contractor in designing the rotorcraft to meet the requirements of this specification. The operational missions considered should include the entire spectrum of intended operational usage. The contractor shall divide each operational mission into segments which will be identified as Flight Phases. Each Flight Phase shall be assigned to the appropriate Flight Region of 1.3. Operational Capability Classification of 1.4 and Flight Phase Category of 1.5.

1.3 FLIGHT REGIONS

The flying and ground handling requirements of this specification are separately stated for each of the following Flight Regions.

1.3.1 Hover and Low Speed

Flight in hover or at speeds less than the speed for minimum power required. Includes forward, rearward, and sideward flight relative to the air mass.

1.3.2 Forward Flight

Forward flight at true airspeed greater than the speed for minimum power required.

1.3.3 Accelerating and Decelerating Transition

Accelerating or decelerating transitions between Hover and Low Speed and Forward Flight.

1.3.4 Autorotation

Flight with engine at Flight Idle or failed.

1.3.5 Takeoff and Landing

Takeoff from the landing surface and return to the landing surface.

1.3.6 Ground Handling

Operation of the rotorcraft while on the ground, water or other landing surface.

1.4

CLASSIFICATION OF REQUIRED OPERATIONAL CAPABILITY

The procuring activity will designate the conditions of external visibility in which each Flight Phase defined in 1.2 must be performed. The procuring activity will assign each Flight Phase to one of the four cells of the following matrix based on whether mission requirement is for operation in the Flight Phase only when external visual cues are available to the unaided eye or whether the mission requirement is for operation in the Flight Phase even when external visual cues are not available to the unaided eye.

REQUIRED OPERATIONAL CAPABILITY

External Visual Conditions in Which Operational Capability is Required	Only When Position and Velocity Cues Are Available	Even When Position and Velocity Cues are Not Available
Only when Angular Orientation Cues are Available	Class I	Class II
Even when Angular Orientation Cues are Not Available	Class III	Class IV

Class Is, IIs, IIIs, IVs designates that the rotorcraft must be designed for operation in the Flight Phase by one crewman.

1.5 CATEGORIZATION OF FLIGHT PHASES

The Flight Phases of 1.2 shall be characterized and categorized by the contractor subject to the approval of the procuring activity. The contractor shall characterize each Flight Phase using the following characteristics and characterizations.

CHARACTERISTICS	CHARACTERIZATIONS	
Maneuvering Required M	Rapid 1	Gradual 0
Precise* Flight Path or Space Position Control Required P	Yes 1	No 0
Target Tracking Required T	Yes 1	No 0

Flight Phase Categories are defined as the following combinations of the characterizations of the characteristics.

M	P	T	Examples
1	1	1	Ground Attack
1	1	0	Terrain Avoidance, NOE
1	0	1	Air-Air Combat With Missiles
1	0	0	Missile Avoidance
0	1	1	Hover Bob-Up & Target Acquisition
0	1	0	External Load Placement
0	0	1	Missile Launch
0	0	0	Loiter

*Quantitative definitions of precise flight path or space position control must be made by the procuring activity for certain Flight Phases in specific procurements. Examples are

- External load positioning accuracy required.
- Minimum visual range and minimum descent altitude required for approach to landing operations.

Quantitative definitions of the precision or accuracy required in specific Flight Phases will determine the accuracy of sensors and guidance systems and may influence the need for stabilization and/or gust alleviation.

1.6 LEVELS OF FLYING QUALITIES

Three Levels of flying qualities are defined as follows:

- Level 1: Flying qualities clearly satisfactory for the mission Flight Phase.
- Level 2: Flying qualities adequate to accomplish the mission Flight Phase, but some increase in pilot workload or degradation in mission effectiveness, or both, exists.
- Level 3: Flying qualities such that the rotorcraft can be controlled safely, in the mission Flight Phase, but pilot workload is excessive or mission effectiveness is inadequate, or both.

Where possible, the requirements of Section 3 have been stated in terms of three values of flying qualities parameters. Each value specified is a minimum condition to meet one of the defined levels of flying qualities. Ideally, values of the flying qualities parameters required for each level should be stated for each Flight Phase and Flight Environment for which the rotorcraft is to be designed. Available data does not permit this degree of specification. Some of the requirements, therefore, are qualitative or define a required operational capability. In these requirements, flying qualities parameters are not defined. It must be noted that while any flying qualities requirement or group of requirements may be necessary conditions for good flying qualities, meeting all the specified requirements may not be sufficient to ensure that the desired Level of flying qualities is achieved. The final decision as to whether or not the rotorcraft is approved will therefore depend on assessment of the overall characteristics.

2 DEFINITIONS AND APPLICABLE DOCUMENTS

2.1 DEFINITIONS OF THE ROTORCRAFT

2.1.1 Loadings

The contractor shall define the envelopes of center of gravity and corresponding weights that will exist for each Flight Phase. These envelopes shall include the most forward and aft center-of-gravity positions as defined in MIL-W-25140. In addition, the contractor shall determine the maximum center-of-gravity excursions attainable through failures in systems or components, such as fuel sequencing, hung stores, etc., for each Flight Phase to be considered in the Failure States of 2.1.4.2. Within these envelopes, plus a growth margin to be specified by the procuring activity, and for the excursions cited above, this specification shall apply.

2.1.2 Moments of Inertia and Products of Inertia

The contractor shall define the moments of inertia and products of inertia associated with all loadings of 2.1.1. The requirements of this specification shall apply for all moments of inertia and products of inertia so defined.

2.1.3 External Stores

The requirements of this specification shall apply for all combinations of external stores and all methods of attachment of external stores required by the operational missions. The effects of external stores on the weight, moments of inertia, center-of-gravity position, and aerodynamic characteristics of the combined rotorcraft and external stores shall be considered for each mission Flight Phase. When the stores contain expendable loads, the requirements of this specification apply throughout the range of store loadings. The external stores and store combinations to be considered for flying qualities design will be specified by the procuring activity. In establishing external store combinations to be investigated, consideration shall be given to asymmetric as well as to symmetric combinations, and to variations in mass distribution within external stores.

2.1.4 Configurations

The requirements of this specification shall apply for all configurations required or encountered in the applicable Flight Phases of 1.2. A (crew-) selected configuration is defined by the positions and adjustments of the various selectors and controls available to the crew (except for the primary longitudinal, lateral, yaw, thrust magnitude, and trim controls), for example, flap setting, R.P.M. setting, thrust vector setting, stability-augmentation-system (SAS)-selector setting, etc. The selected configurations to be examined must consist of those required for performance and mission accomplishment. Additional configurations to be investigated may be defined by the procuring activity.

2.1.5 State of the Rotorcraft

The State of the rotorcraft is defined by the selected configuration together with the functional status of each of the aircraft components or systems, thrust magnitude, weight, moments of inertia, center-of-gravity position, and external store complement. The trim setting and the positions of the longitudinal, lateral, and yaw controls are not included in the definition of Rotorcraft State since they are often specified in the requirements. The position of the thrust magnitude control shall not be considered an element of the Rotorcraft State when the thrust magnitude is specified in a requirement.

2.1.5.1 Rotorcraft Normal States

The contractor shall define and tabulate all pertinent items to describe the Aircraft Normal (no component or system failure) State(s) associated with each of the applicable Flight Phases. Certain items, such as weight, moments of inertia, center-of-gravity position, thrust magnitude and thrust angle control settings, may vary continuously over a range of values during a Flight Phase. The contractor shall replace this continuous variation by a limited number of values of the parameter in question which will be treated as specific States, and which include the most critical values and the extremes encountered during the Flight Phase in question.

2.1.5.2 Rotorcraft Failure States

The contractor shall define and tabulate all Rotorcraft Failure States, which consist of Rotorcraft Normal States modified by one or more malfunctions in rotorcraft components or systems; for example, a discrepancy between a selected configuration and an actual configuration. Those malfunctions that result in center-of-gravity positions outside the center-of-gravity envelope defined in 2.1.1 shall be included. Each mode of failure shall be considered. Failures occurring in any Flight Phase shall be considered in all subsequent Flight Phases.

2.1.5.3 Rotorcraft Specific Failure States

Requirements are included which limit the effects of specific failures. These requirements shall be met on the basis that the Specific Failure has occurred, regardless of its probability of occurrence. Consideration of a failure as a Specific Failure does not exempt that same failure from consideration on a probability basis according to 2.3.3.

2.1.5.4 Rotorcraft Special Failure States

Certain components, systems, or combinations thereof may have extremely remote probability of failure during a given flight. These failure probabilities may, in turn, be very difficult to predict with any degree of accuracy. Special Failure States of this type need not be considered in complying with the requirements of Section 3.

2.2 DEFINITION OF FLIGHT ENVELOPES

2.2.1 Operational Flight Envelopes

The Operational Flight Envelopes define the boundaries in terms of speed, altitude, and load factor within which the rotorcraft must be capable of operating in order to accomplish the operational missions for which it is being procured. Additional envelopes in terms of parameters such as rate of descent, flight-path angle, stress in critical components, and side velocity may also be specified. Envelopes for each applicable Flight Phase shall be established with the guidance and approval of the procuring activity.

2.2.2 Service Flight Envelopes

For each Rotorcraft Normal State (but with thrust varying as required), the contractor shall establish, subject to the approval of the procuring activity, Service Flight Envelopes showing combinations of speed, altitude, and load factor derived from rotorcraft limits as distinguished from mission requirements. Additional envelopes in terms of parameters such as rate of descent, flight-path angle, and side velocity may also be specified. A certain set or range of Rotorcraft Normal States generally will be employed in the conduct of a Flight Phase. The Service Flight Envelope for these States, taken together, shall at least cover the Operational Flight Envelope for the pertinent Flight Phase.

2.2.3 Operating Limitations

The Operating Limitations shall encompass all regions in which operation of the rotorcraft is allowable. These are the boundaries of flight conditions which the rotorcraft is capable of safely encountering. Transient load factors, power settings, rotor speed, and emergency thrust settings may be representative of such conditions.

2.3 DEFINITIONS OF THE ENVIRONMENT

The environments in which the mission Flight Phases must be accomplished are defined in paragraphs 2.3.1 and 2.3.2. Detail features and mathematical models of the environment are defined in the paragraphs of 3.9.

2.3.1 Operational Environments

Operational Environments define the sets of environmental conditions (in terms of atmospheric conditions, ambient light and terrain characteristics), in which the rotorcraft must be capable of operating in order to accomplish the operational missions for which it is being procured. Operational Environments for each of the following

Flight Regions: Hover and Low Speed
 Forward Flight
 Takeoff and Landing
 Ground Handling

shall be established by the procuring activity. In the absence of specific guidance, the contractor shall use the representative conditions of paragraph 3.9 for the applicable Flight Regions.

2.3.2 Most Severe Environments

The Most Severe Environmental conditions define the sets of environmental conditions (in terms of atmospheric conditions, ambient light and terrain characteristics) in which the rotorcraft must be capable of safe operation. The Most Severe Environmental Conditions for each of the following Flight Regions:

 Hover and Low Speed
 Forward Flight
 Takeoff and Landing
 Ground Handling

shall be established by the procuring activity. In the absence of specific guidance, the contractor shall use the severe environment conditions of paragraph 3.9 for the applicable Flight Regions.

2.4 DEFINITION OF CONDITIONS FOR WHICH DEGRADED FLYING QUALITIES ARE PERMITTED

2.4.1 Applications of Levels

Levels of flying qualities as indicated in 1.6 are employed in realization of the possibility that the rotorcraft may be required to operate under abnormal conditions. Such abnormalities that may occur as a result of either flight outside the Operational Flight Envelope, the failure of rotorcraft components, or flight in a severe environment are permitted to comply with the degraded Level of flying qualities as specified in 2.4.2 through 2.4.3.

2.4.2 Requirements for Rotorcraft Normal States

The minimum required flying qualities for Rotorcraft Normal States (2.1.5.1) are as shown in Table I.

**Table I
LEVELS FOR ROTORCRAFT NORMAL STATES**

	Within Operational Flight Envelope	Within Service Flight Envelope
Operational Environmental	Level 1	Level 2
Most Severe Environment	Landing Flight Phase Level 2 All Other Flight Phases Level 3	Capability Not Required

2.4.3 Requirements for Rotorcraft Failure States

When Rotorcraft Failure States exist, a degradation in flying qualities is permitted only if the probability of encountering a lower Level than specified in 2.4.2 is sufficiently small. At intervals during the design process, the designer shall determine, based on the most accurate available data, the probability of occurrence of each Rotorcraft Failure State per flight and the effect of that Failure State on the flying qualities within the Operational and Service Flight Envelopes. These determinations shall be made under the following assumptions: (a) all rotorcraft components and systems are assumed to be operating for a time period, per flight, equal to the longest operational mission time to be considered by the designer in designing the rotorcraft, and (b) each specific failure is assumed to be present at whichever point in the Flight Envelope being considered is most critical (in the flying qualities sense). From these Failure State probabilities and effects, the designer shall determine the overall probability, per flight, that one or more flying qualities are degraded to Level 2 because of one or more failures. The designer shall also determine the probability that one or more flying qualities are degraded to Level 3. These probabilities shall be less than the values shown in Table II.

**Table II
LEVELS FOR ROTORCRAFT FAILURE STATES**

Probability of Encountering	Within Operational Flight Envelope	Within Service Flight Envelope
Level 2 after failure	10^{-2} per flight	
Level 3 after failure	10^{-4} per flight	10^{-2} per flight

In no case shall a Failure State (except an approved Special Failure State) degrade any flying quality outside the Level 3 limit.

2.4.4 Explanatory Notes Concerning Application of Levels

2.4.4.1 Conceptual Diagrams of Design Evaluation Process

The design evaluation process is illustrated by the conceptual diagrams shown in Figures 1 and 2.

2.4.4.2 Theoretical Compliance

Part of the intent of 2.4.3 is to ensure that the probability of encountering significantly degraded flying qualities because of component or subsystem failures is small.

To determine theoretical compliance with the requirements of 2.4.3, the following steps must be performed:

- a) Identify those Rotorcraft Failure States which have a significant effect on flying qualities (2.1.5.2).
- b) Define the longest flight duration to be encountered during operational missions.
- c) Determine the probability of encountering various Rotorcraft Failure States, per flight, based on the above flight duration (2.4.3).
- d) Determine the degree of flying qualities degradation associated with each Rotorcraft Failure State in terms of Levels as defined in the specific requirements.
- e) Determine the most critical Rotorcraft Failure States (assuming the failures are present at whichever point in the Flight Envelope being considered is most critical in a flying qualities sense), and compute the total probability of encountering Level 2 flying qualities in the Operational Flight Envelope, etc.

- f) Compare the computed values above with the requirements in 2.4.3. An example which illustrates an approximate estimate of the probabilities of encounter follows: if the failures are all statistically independent, determine the sum of the probabilities of encountering all Rotorcraft Failure States which degrade flying qualities to Level 2 in the Operational Envelope. This sum must be less than 10^{-2} per flight.

If the requirements are not met, the designer must consider alternate courses such as:

- a) Improve the rotorcraft flying qualities associated with the more probable Failure States, or
- b) Reduce the probability of encountering the more probable Failure States through equipment redesign, redundancy, etc.

Regardless of the probability of encountering any given Rotorcraft Failure States (with the exception of Special Failure States) the flying qualities shall not degrade below Level 3.

2.4.4.3 Definitions of Level Regions

To determine the degradation in flying qualities parameters for a given Rotorcraft Failure State the following definitions are provided:

- a) Level 1 region is better than or equal to the Level *i* boundary, or number, given in the design criteria.
- b) Level 2 region is worse than Level 1, but no worse than the Level 2 boundary, or number.
- c) Level 3 region is worse than Level 2, but no worse than the Level 3 boundary, or number.

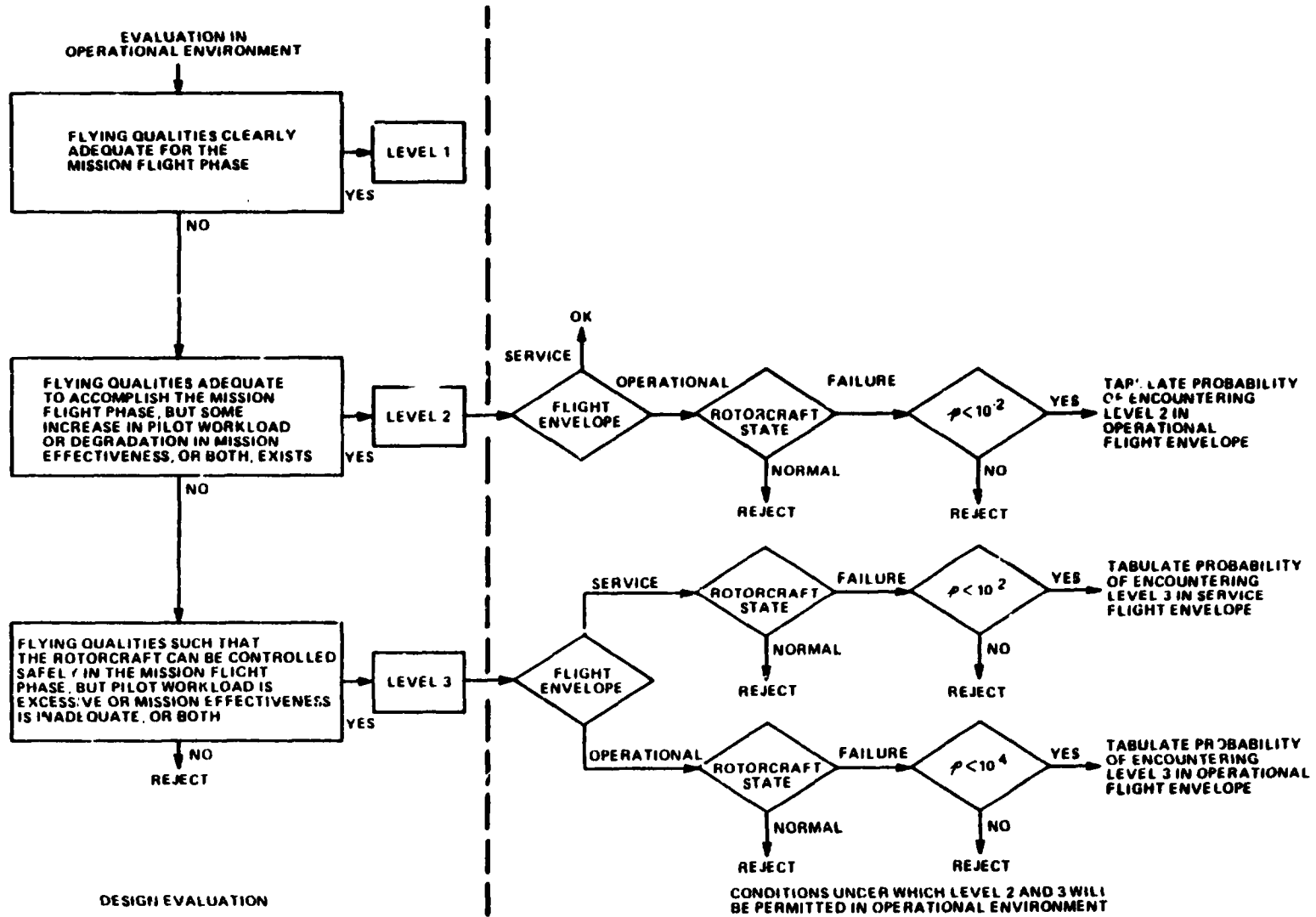

Figure 1 DEFINITION OF CONDITIONS UNDER WHICH LEVEL 2 AND LEVEL 3 FLYING QUALITIES WILL BE PERMITTED IN THE OPERATIONAL ENVIRONMENT

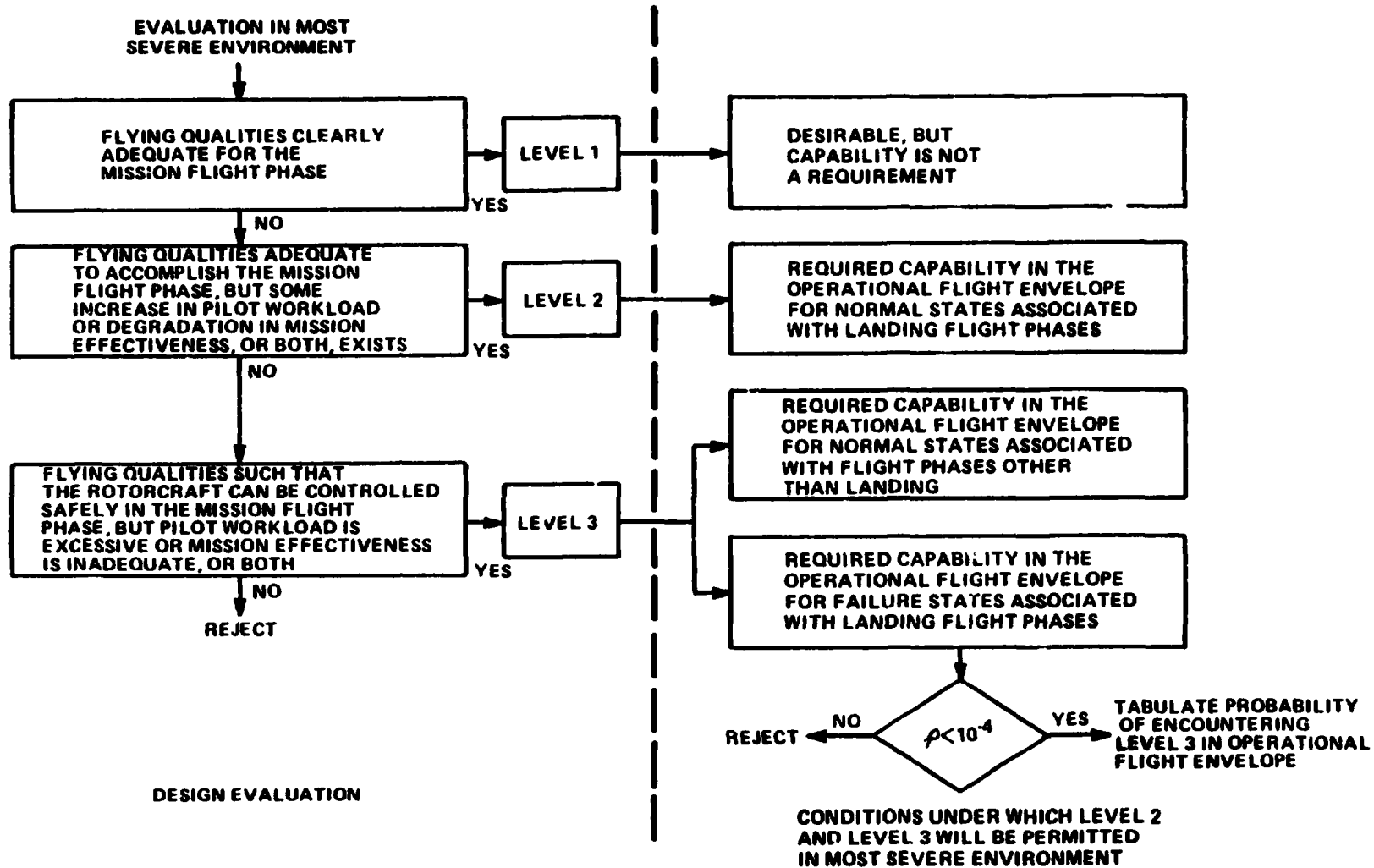

Figure 2 DEFINITION OF CONDITIONS UNDER WHICH LEVEL 2 AND LEVEL 3 FLYING QUALITIES WILL BE PERMITTED IN THE MOST SEVERE ENVIRONMENT

When a given boundary, or number, is identified as Level 1 and Level 2, this means that flying qualities outside the boundary conditions shown, or worse than the number given, are at best Level 3 flying qualities. Also, since Level 1 and Level 2 requirements are the same, flying qualities must be within this common boundary, or number, in both the Operational and Service flight Envelopes for Rotorcraft Normal States (2.4.2). Rotorcraft Failure States that do not degrade flying qualities beyond this common boundary are not considered in meeting the requirements of 2.4.3. Rotorcraft Failure States that represent degradations to Level 3 must, however, be included in the computation of the probability of encountering Level 3 degradations in both the Operational and Service Flight Envelopes. Again degradation beyond the Level 3 boundary is not permitted regardless of component failures.

2.4.4.4 Computational Assumptions

Assumptions a) and b) of 2.4.3 are somewhat conservative, but they simplify the required computations in 2.4.3 and provide a set of workable ground rules for theoretical predictions. The reasons for these assumptions are:

- a) "...components and systems are ... operating for a time period per flight equal to the longest operational mission time ...". Since most component failure data are in terms of failures per flight hour, even though continuous operation may not be typical (e.g., yaw damper ON during hovering flight only), failure probabilities must be predicted on a per flight basis using a "typical" total flight time. The "longest operational mission time" as "typical" is a natural result. If acceptance cycles-to-failure reliability data are available, these data may be used for prediction purposes based on maximum cycles per operational mission. In any event, compliance with the requirements of 2.4.2 is based on the probability of encounter per flight.
- b) "...failure is assumed to be present at whichever point ... is most critical ...". This assumption is in keeping with the requirements of 2.1.5.2 regarding Flight Phases subsequent to the actual failure in question. In cases that are unrealistic from the operational standpoint, the specific Rotorcraft Failure States might fall in the Rotorcraft Special Failure State classification (2.1.5.3).

2.5 APPLICABLE DOCUMENTS

3 FLYING QUALITIES REQUIREMENTS FOR CLASS 1

3.1 HOVER AND LOW SPEED

3.1.1 Equilibrium control gradients with airspeed

The requirements in Table 3.1-1 shall be satisfied at all forward trim speeds, backward trim speeds, and sideward trim speeds both to the left and to the right, up to the limits of the Service Flight Envelope. This requirement shall apply for airspeed perturbations of at least 10 Knots in both directions about the trim airspeed except that the rotorcraft need not exceed the limits of the service flight envelope. The configuration selectors and cockpit trim controller setting may be different at each trim condition, but they must remain fixed while establishing the control gradients.

Table 3.1-1
CONTROL GRADIENTS WITH AIRSPEED

Flight Phase Category	Gradient with Airspeed of:	Level		
		1	2	3
XIX	Force	Stable or Zero	Stable or Zero	$\Delta F < 1.0$ lb.
	Position	Stable or Zero	Stable or Zero	$\Delta \delta < 0.5$ inch
X0X	Force	Stable or Zero	$\Delta F < 1.0$ lb.	$\Delta F < 1.0$ lb.
	Position	Stable or Zero	$\Delta < 0.5$ inch.	$\Delta \delta < 0.5$ inch

Stable longitudinal control gradient means that incremental pull force and aft displacement of the longitudinal cyclic controller are required to maintain slower or more rearward airspeed and the opposite to maintain faster or more forward airspeed.

Stable directional control gradients mean that incremental right force and right displacement of the directional controller are required to maintain left translations or left side slips and the opposite to maintain right translations or right sideslips.

Stable lateral control gradients mean that incremental right force and right displacement of the lateral controller are required to maintain right translations or right sideslips and the opposite to maintain left translations at left sideslips.

The variation of airspeed with control force and control position shall be smooth and essentially linear with no abrupt changes in gradient within the specified speed range. The term gradient does not include that portion of the control force or control position versus airspeed curve within the preloaded breakout force or friction band. A moderately unstable local gradient is permitted for Levels 2 and 3 in Table 3.1-1 but the magnitude of the change in control force (ΔF) or control position ($\Delta\delta$) in the unstable direction, within the specified speed range, is limited as indicated in Table 3.1-1.

3.1.2 Dynamic Stability Requirements

The requirements in Tables 3.1-2, 3.1-3 shall apply to the dynamic responses of the rotorcraft with the cockpit controls free and with them fixed following an external disturbance or an abrupt cyclic, directional or collective doubled, pulse or step control input in either direction. The requirements apply for responses of any magnitude that might be experienced in operational use. If oscillations are nonlinear with amplitude, the oscillatory requirements shall apply to each cycle of the oscillation.

Table 3.1-2
APERIODIC DIVERGENCE

Flight Phase Category	Level		
	1	2	3
XIX	Stable	Stable	$t_2 > 5$ sec
X0X	Stable	$t_2 > 12$ sec	$t_2 > 5$ sec

Table 3.1-3
OSCILLATORY MODES

Flight Phase Category	Level		
	1	2	3
XIX	A	B	D
X0X	B	C	D

A	$P < 1.25 \text{ sec}$	$C_{1/2} < 2$	$\zeta > .055$
	$1.25 \text{ sec} < P < 5.7 \text{ sec}$	$C_{1/2} < .35$	$\zeta > .30$
	$P > 5.7 \text{ sec}$	$C_{1/2} < \infty$	$\zeta > 0$
B	$P < 1.25 \text{ sec}$	$C_{1/2} < 2$	$\zeta > .055$
	$1.25 \text{ sec} < P < 6 \text{ sec}$	$C_{1/2} < .7$	$\zeta > .15$
	$6 \text{ sec} < P < 12 \text{ sec}$	$C_{1/2} < \infty$	$\zeta > 0$
	$P > 12 \text{ sec}$	$C_2 > 1$	$\zeta > -.1$
C	$P < 1.25 \text{ sec}$	$C_{1/2} < 2$	$\zeta > .055$
	$1.25 \text{ sec} < P < 7.5 \text{ sec}$	$C_{1/2} < \infty$	$\zeta > 0$
	$P > 7.5 \text{ sec}$	$t_2 > 12 \text{ sec}$	$\zeta \omega_n > -.058$
D	$P < 1.25 \text{ sec}$	$C_{1/2} < 2$	$\zeta > .055$
	$1.25 \text{ sec} < P < 5 \text{ sec}$	$C_{1/2} < \infty$	$\zeta > 0$
	$P > 5 \text{ sec}$	$t_2 > 5 \text{ sec}$	$\zeta \omega_n > -.14$

3.1.2.1 Effective time delay in angular rate and rate of climb. The effective time delay in the pitch [roll] (yaw) angular rate and {rate of climb} response to a step force command to the pitch [roll] (yaw) {collective} cockpit controller shall be less than the magnitude specified in Table 3.1-4 and 3.1-5. The effective time delay shall be measured by the maximum slope intercept method. Time zero, t_0 , is defined as the time at which the force step passes through 50% of the step magnitude. Time t_1 is the time at which a straight line, drawn tangent to the response rate time history at the maximum slope, intersects the initial magnitude of the rate response, usually zero rate.

Table 3.1-4
EFFECTIVE TIME DELAY IN ANGULAR RATE (SECOND)

Flight Phase Category	Level		
	1	2	3
XIX	0.10	0.15	0.25
XOX	0.15	0.20	0.25

Table 3.1-5
EFFECTIVE TIME DELAY IN RATE OF CLIMB (SECOND)

Flight Phase Category	Level		
	1	2	3
XIX	0.25	0.70	0.70
XOX	0.70	0.70	0.70

3.1.2.2 Angular rate response time. The response time of pitch [roll] (yaw) angular rate to the input of 3.1.2.1 shall be less than the magnitudes specified in Table 3.1-6. Response time is defined as the difference between $t_{63.2}$ and t_1 . Rotorcraft demonstrated to be non responsive directionally to side gusts and ground effects, may, at the discretion of the procuring activity, be granted a deviation from the yaw rate damping requirement.

Table 3.1-6
ANGULAR RATE RESPONSE TIME (SECONDS)

$$t_R = t_{63.2} - t_1$$

Flight Phase Category	Level		
	1	2	3
XIX	0.5	1.0	-
XOX	1.0	1.5	-

3.1.2.3 Rate of climb response time. The response time of rate of climb or rate of descent to the input of 3.1.2.1 shall be less than the magnitudes specified in Table 3.1-7. Response time is defined as in 3.1.2.2.

Table 3.1-7
RATE OF CLIMB/DESCENT RESPONSE TIME (SECONDS)

Flight Phase Category	Level		
	1	2	3
XIX	2	4	-
X0X	4	6	-

3.1.2.4 Vertical oscillations. There shall be no objectionable vertical oscillations resulting from lag in governor response, collective control dynamics, load suspension dynamics and pilot effort to control altitude and vertical velocity.

3.1.2.5 Rotor RPM Variation. The engine, transmission, drive shafts, rotor and engine governor shall be designed such that rotor RPM remains within allowable limits relative to the RPM selected by the pilot, during all transient and steady state maneuvers required by the operational mission Flight Phases. Rotor RPM oscillations that are large enough in amplitude and low enough in frequency to cause noticeable variations in rotor thrust and rotorcraft rate of climb following abrupt collective commands are unacceptable.

3.1.3 Precision Load Placement

When precision load placement is a mission requirement, Flight Phase Category XIX, the dynamics of the rotorcraft and the load handling system must be integrated to achieve the mission objectives. Load placement tolerance and mean time for load transport and placement may be suitable for specifying system performance.

3.1.4 Target Tracking

When target tracking is a mission requirement, Flight Phase Categories XXI, the dynamics of the rotorcraft, the target tracking system and the weapon system must be integrated to achieve the mission objectives. Appropriate considerations must be given to target acquisition and target tracking.

3.1.5 Control for Trim

The capability to obtain steady flight throughout the Service Flight Envelope associated with each Flight Phase in the Hover and Low Speed Flight Region shall not be limited by the pitch [roll] (yaw) control power available.

3.1.6 Control Power

There shall be sufficient control power available, over that required for trim, to counter variations in winds and turbulence and to perform the maneuvers associated with each Flight Phase in the Hover and Low Speed Flight Region. The control power margin available to the pilot shall be such that when the available pitch [roll] (yaw) control is rapidly applied, the change in pitch [roll] (yaw) attitude within one second shall be equal to or greater than the magnitudes specified in Table 3.1-8.

Table 3.1-8
ATTITUDE CHANGE WITHIN ONE SECOND (DEGREES)

Flight Phase Category	Level								
	1			2			3		
	Pitch	Roll	Yaw	Pitch	Roll	Yaw	Pitch	Roll	Yaw
IXX	+4.5	+6	+9	+3	+3.5	+4.5	+2	+2	+2
OXX	+3	+4	+6	+2	+2.5	+3	+2	+2	+2

3.1.6.1 Alternate Requirements. In the conditions defined in 3.1.6, the control power margin available to the pilot shall be such that when the available pitch [roll] (yaw) control is rapidly applied, the change in pitch [roll] (yaw) angular rate occurring within 1.5 seconds shall be equal to or greater than the magnitudes specified in Table 3.1-9.

Table 3.1-9
ANGULAR RATE CHANGE WITHIN 1.5 SECONDS

Flight Phase Category	Level		
	1	2	3
1XX	$\pm 15^\circ/\text{sec}$	$\pm 10^\circ/\text{sec}$	$\pm 7^\circ/\text{sec}$
0XX	$\pm 10^\circ/\text{sec}$	$\pm 10^\circ/\text{sec}$	$\pm 7^\circ/\text{sec}$

3.1.6.2 Height Control Power. The steady state thrust-weight ratio in zero airspeed hover free of ground effect shall be equal to or greater than the magnitude specified in Table 3.1-10.

Table 3.1-10
THRUST TO WEIGHT RATIO IN HOVER

Flight Phase Category	Level		
	1	2	3
1XX	1.05	1.025	1.0
0XX	1.025	1.01	1.0

3.1.7 Control-Response Sensitivity

The ratio of the maximum pitch [roll] (yaw) attitude change, occurring within the first second following an abrupt command from the pitch [roll] (yaw) cockpit controller, to the magnitude of the controller command shall lie within the bounds of Table 3.1-11. There shall be no objectionable nonlinearities in the response of the rotorcraft to control commands by the pilot. This requirement applies to conventional floor-mounted center sticks and rudder pedals.

Table 3.1-11
RESPONSE-INPUT RATIOS
(DEGREES WITHIN ONE SECOND PER INCH)

Level	Pitch		Roll		Yaw	
	Min.	Max.	Min.	Max.	Min.	Max.
1	3	20	4	20	6	23
2	2	30	2.5	30	3	45
3	1	40	1	40	1	50

3.1.7.1 Collective Control-response ratio. The ratio of the maximum rate of climb, occurring within the first second following an abrupt command from the collective controller, to the magnitude of the collective controller command shall lie within the bounds of Table 3.1-12. This requirement applies to conventional collective lever designs.

Table 3.1-12
RESPONSE-INPUT RATIOS - COLLECTIVE
(FEET PER MINUTE PER INCH)

Level	Collective	
	Min.	Max
1	100	750
2	50	1200
3	-	2000

3.1.8 Trim Variation with Power or Collective

The rotorcraft shall not exhibit excessive trim changes when engine power or collective pitch, or both, are varied. Specifically, when starting from trim at any combination of power and airspeed within the Service Flight Envelopes associated with the Hover and Low Speed Flight Region, it shall be possible to maintain pitch, roll and yaw equilibrium using control displacements and forces smaller than the magnitudes specified in Table 3.1-13 as the engine power or collective-pitch, or both, are varied slowly or rapidly in either direction throughout the available range.

Table 3.1-13
TRIM VARIATIONS WITH POWER OR COLLECTIVE

Level	Controller					
	Pitch		Roll		Yaw	
	Force	Displacement	Force	Displacement	Force	Displacement
1	+5 lb.	+1.0 inch	+2 lb.	+0.7 inch	+7 lb.	+0.7 inch
2	+7.5 lb.	+1.5 inch	+3 lb.	+1 inch	+10 lb.	+1 inch
3	+15 lb.	+3 inch	+6 lb.	+2 inch	+20 lb.	+2 inch

3.1.9 Translational Flight in Ground Effect

From hover, at a minimum rotor height corresponding to h/d ratio (main rotor height above ground/main rotor diameter) of 0.4, it shall be possible to stabilize at any airspeed up to 35 KTAS in any direction relative to the nose of the aircraft without requiring excessive flight, power or thrust control manipulation.

3.1.10 Response to horizontal wind gust. It shall be possible to maintain heading and position relative to the ground within desired tolerance, when hovering at a minimum rotor height corresponding to an h/d ratio of 0.4, during horizontal wind gusts of 50 percent of the maximum translational flight airspeed (applied from any azimuth relative to the nose of the rotorcraft as a 0.5 second ramp input, a 0.5 second duration at peak velocity, and 0.5 second ramp decrease) without any control contacting the control stop.

3.1.11 Longitudinal Control force in lateral translational flight. The longitudinal trim force change associated with accelerating or decelerating sideward flight shall not exceed 5 pounds in the pull direction or 2.5 pounds in the push direction.

3.2 FORWARD FLIGHT

3.2.1 Longitudinal equilibrium control gradients with speed. The requirements in Table 3.2-1 shall be satisfied at all forward trim airspeeds from the speed for minimum power required to the maximum forward speed limit of the service flight envelope. This requirement shall apply for airspeed perturbations of +15 knots from the trim airspeed except where limited by the boundaries of the Service Flight Envelope.

The configuration selectors and cockpit trim controller setting may be different at each trim condition but they must remain fixed while establishing the control gradients.

Table 3.2-1

LONGITUDINAL CONTROL GRADIENTS WITH AIRSPEED

Flight Category	Gradient with Airspeed of:	Level		
		1	2	3
XIX	Force	Stable or Zero	Stable or Zero	$\Delta F < 1.0$ lb.
	Position	Stable or Zero	Stable or Zero	$\Delta \delta < 0.5$ inch
X0X	Force	Stable or Zero	$\Delta F < 1.0$ lb.	$\Delta F < 1.0$ lb.
	Position	Stable or Zero	$\Delta \delta < 0.5$ inch	$\Delta \delta < 0.5$ inch

Stable longitudinal control gradient means that incremental pull force and aft displacement of the longitudinal cyclic controller are required to maintain slower airspeed and the opposite to maintain faster airspeed.

The variation of control force and control position with airspeed shall be smooth and essentially linear with no abrupt changes in gradient within the specified speed range. The term gradient does not include that portion of the control force or control position versus airspeed curve within the preloaded breakout force or friction band. A moderately unstable local gradient is permitted for Levels 2 and 3 in Table 3.2-1 but the magnitude of the change in control force (ΔF) or control position ($\Delta \delta$) in the unstable direction, within the specified airspeed range, is limited as indicated in Table 3.2-1.

3.2.2 Longitudinal Dynamic Requirements

3.2.2.1 Longitudinal Dynamic Stability. The requirements in tables 3.2-2, 3.2-3 shall apply to the dynamic response of the rotorcraft with the longitudinal cyclic controller free and with it held fixed. These requirements apply to the dynamic responses following a disturbance in smooth air, and following abrupt doublet, pulse or step cyclic inputs in each direction, for responses of any magnitude that might be experienced in operational use. If resulting oscillations are nonlinear with amplitude, the requirements shall apply to each cycle of the oscillations.

Table 3.2-2
APERIODIC DIVERGENCE

Flight Phase Category	Level		
	1	2	3
XIX	Stable	Stable	$t_2 > 6$ sec.
X0X	Stable	$t_2 > 12$ sec.	$t_2 > 6$ sec.

Table 3.2-3
LONGITUDINAL OSCILLATORY MODES

Flight Phase Category	Level		
	1	2	3
XIX	A	B	C
X0X	B	B	C

A	$P < 1$ sec $1 \leq P \leq 10$ sec. $P > 10$ sec.	$C_{1/2} \leq 2$ or $\zeta > .055$ $C_{1/2} \leq .3$ or $\zeta > .35$ $T_{1/2} \leq .69$ or $\zeta \omega_n \geq 1.0$ $C_{1/2} \leq \infty$ or $\zeta \geq 0$
---	---	--

B	$P < 1$ sec. $1 \leq P \leq 10$ sec. $P > 10$ sec	$C_{1/2} \leq 2$ or $\zeta \geq .055$ $C_{1/2} \leq .54$ or $\zeta \geq .20$ $T_{1/2} \leq 1.39$ or $\zeta \omega_n \geq .5$ $C_{1/2} \leq \infty$ or $\zeta \geq 0$
---	---	---

C	$P < 10$ sec $P \geq 10$ sec	$C_{1/2} \leq 2$ $\zeta \geq .055$ $C_2 > 1$ $\zeta \geq -.1$
---	---------------------------------	--

3.2.2.2 Longitudinal dynamic response. The pitch rate and angle of attack responses of the rotorcraft shall satisfy the requirements specified in Tables 3.2-4, 3.2-5, and 3.2-6. The parameters specified in these tables are measured from time histories

of pitch rate and angle of attack in response to a step force command to the longitudinal cyclic controller which is applied for three seconds and then removed (decreasing step) and maintained at zero for an additional three seconds. The rotorcraft shall be in steady trimmed flight prior to application of the controller command.

Table 3.2-4
PITCH RATE RISE TIME (SECONDS)

$$\Delta t = \Delta q_{ss} / \dot{q}_{Max.}$$

Flight Phase Category	Level		
	1	2	3
XIX	$\Delta t \leq 115/V_T$	$\Delta t \leq 201/V_T$	-
X0X	$\Delta t \leq 201/V_T$	$\Delta t \leq 503/V_T$	-

where V_T is in ft/sec

Table 3.2-5
PITCH RATE EFFECTIVE TIME DELAY t_l (SECONDS)

Flight Phase Category	Level		
	1	2	3
XIX	.1	.15	.25
X0X	.15	.2	.25

Table 3.2-6
 $\Delta \alpha_t = 6 / \Delta \alpha_t = 3$ RATIO

Flight Phase Category	Level		
	1	2	3
XIX			-
X0X	-	-	-

3.2.2.3 Target tracking. When target tracking is a mission requirement, Flight Phase Categories XXI, the dynamics of the rotorcraft, the target tracking system and the weapon system must be integrated to achieve the mission objectives. Appropriate

consideration must be given to target acquisition and target tracking. Generalizations of the performance measures proposed in Ref. (Onstott) may be suitable for specifying system performance.

3.2.3 Longitudinal Control in unaccelerated flight.

The capability to obtain steady flight throughout the Service Flight Envelope associated with each Flight Phase in the Forward Flight Region shall not be limited by the effectiveness of the longitudinal control or controls.

3.2.4 Longitudinal control effectiveness in maneuvering flight

When the rotorcraft is trimmed in unaccelerated flight at any speed and altitude in the Operational Flight Envelope, it shall be possible by use of the longitudinal cyclic and collective pitch controls to develop, at the trim speed, the limiting angle of attack or load factor of the Operational Flight Envelope.

3.2.5 Longitudinal control gradients in maneuvering flight

In steady turning flight, in pullups and in pushovers, at constant speed, the variation in longitudinal cyclic control force and controller position with steady-state normal acceleration shall be approximately linear with increasing pull force and aft displacement required to increase normal acceleration. A departure from linearity resulting in a local gradient which differs from the average gradient for the maneuver by more than 50 percent is considered excessive. The local gradients of control force with load factor shall be within the limits specified in Table 3.2-7.

Table 3.2-7
STICK FORCE PER g (POUNDS/g)

Level	Min	Max
1	6	20
2	4	20
3	2	30

The term gradient does not include that portion of the force versus normal-acceleration curve within the preloaded breakout force or friction band.

3.2.6 Longitudinal control forces in dives

With the rotorcraft trimmed for level flight at V_H , the longitudinal force required for dives to all attainable airspeeds within the Service Flight Envelope shall not exceed the limits specified in Table 3.2-8.

Table 3.2-8
CONTROL FORCES IN DIVES (POUNDS)

Level	Push	Pull
1	30	0
2	30	5
3	30	10

3.2.7 Longitudinal control in sideslips

With the rotorcraft trimmed for straight flight with zero bank angle at any point in the Operational Flight Envelope, the longitudinal control force required to maintain constant speed in the sideslips of paragraph 3.2.9 shall not exceed the limits specified in Table 3.2-9. The gradient of longitudinal control force with sideslip shall be essentially symmetrical about the zero sideslip condition.

Table 3.2-9
LONGITUDINAL CONTROL FORCE IN SIDESLIPS (POUNDS)

Level	Push	Pull
1	2	5
2	3	10
3	10	10

3.2.8 Longitudinal control force variations due to gusts and collective inputs

There shall be no objectional longitudinal cyclic control force variations resulting from gust encounters or pilot inputs to the collective controller.

3.2.9 Lateral-directional characteristics in steady sideslips

The requirements for 3.2.9.1 through 3.2.9.4 are expressed in terms of characteristics in rudder pedal induced, steady, zero-yaw-rate sideslips with the rotocraft trimmed for zero-bank-angle straight flight. Sideslip angles to be demonstrated shall be the lesser of the sideslip limit of the Service Flight Envelope, full rudder pedal displacement or a rudder pedal force of 125 pounds.

3.2.9.1 Yawing moments in steady sideslips. The variation of rudder pedal displacement and rudder pedal force with sideslip angle shall be stable and essentially linear for sideslip angles between +15 and -15 degrees. For larger sideslip angles, the variation of rudder pedal displacement with sideslip angle shall be stable and, although a reduction in the slope of the variation of rudder pedal force with sideslip angle is acceptable outside this range, the following requirements shall apply:

Level 1: The slope of the variation of rudder pedal force with sideslip angle shall be stable or zero.

Level 2: The slope of the variation of rudder pedal force with sideslip angle is permitted to become unstable but the rudder pedal force shall not decrease below that required for 10° of sideslip in the same direction.

Level 3: The slope of the variation of rudder pedal force with sideslip angle is permitted to become unstable but the rudder pedal force shall not decrease to zero.

Stable variation of rudder pedal displacement and rudder pedal force with sideslip means increasing left rudder pedal displacement and force for increasing right sideslip and the opposite for left sideslip.

3.2.9.2 Bank angle in steady sideslips. For the sideslips specified in 3.2.9, an increase in right bank angle shall accompany an increase in right sideslip, and an increase in left bank angle shall accompany an increase in left sideslip.

3.2.9.3 Rolling moments in steady sideslips. For the sideslips specified in 3.2.9, left lateral controller displacement and force shall be required in left sideslips, and right lateral controller displacement and force shall be required in right sideslips. The variation of lateral controller displacement and force with sideslip angle shall be essentially linear.

3.2.9.4 Lateral control required in steady sideslips. The lateral control required to maintain equilibrium in the sideslips specified in 3.2.9 shall not exceed the percentages, of total lateral control authority available, that are listed in Table 3.2-10.

Table 3.2-10
LATERAL CONTROL LIMITS IN STEADY SIDESLIP (PERCENT)

Flight Phase Category	Level		
	1	2	3
IXX	25%	50%	75%
OXX	50%	50%	75%

3.2.10 Lateral-directional dynamic stability

The requirements in Tables 3.2-11 and 3.2-12 shall apply to the dynamic response of the rotorcraft with the lateral cyclic controller and rudder pedal controller free and with them held fixed. These requirements apply to the dynamic responses

following a disturbance in smooth air, and following abrupt doublet, pulse or step cyclic or pedal inputs in each direction, for responses of any magnitude that might be experienced in operational use. If resulting oscillations are nonlinear with amplitude, the requirements shall apply to each cycle of the oscillation.

Table 3.2-11
APERIODIC DIVERGENCE

Flight Phase Category	Level		
	1	2	3
XIX	Stable	$t_2 > 20 \text{ sec}$	$t_2 > 6 \text{ sec}$
X0X	Stable	$t_2 > 12 \text{ sec}$	$t_2 > 6 \text{ sec}$

Table 3.2-12
OSCILLATORY MODES

Flight Phase Category	Level		
	1	2	3
XIX	A	B	C
X0X	B	B	C

A	$P < 1 \text{ sec}$	$C_{1/2} \leq 2 \text{ or } \zeta > .055$
	$P > 1 \text{ sec}$	$C_{1/2} \leq .6 \text{ or } \zeta > .18$
B	$P < 1 \text{ sec}$	$C_{1/2} \leq 2 \text{ or } \zeta > .055$
	$1 \text{ sec} \leq P \leq 10 \text{ sec}$	$C_{1/2} \leq 1.37 \text{ or } \zeta > .08$
	$P > 10 \text{ sec}$	$C_{1/2} \leq \infty \text{ or } \zeta > 0$
C	$P < 1 \text{ sec}$	$C_{1/2} \leq 2 \text{ or } \zeta \geq .055$
	$1 \text{ sec} \leq P \leq 8 \text{ sec}$	$C_{1/2} \leq \infty \text{ or } \zeta \geq 0$
	$P > 8 \text{ sec}$	$T_2 \geq 5 \text{ sec or } \zeta \omega_n \geq .35$
		$C_2 > .35 \text{ or } \zeta \geq -.3$

3.2.10.1 Effective time delay and response time. The roll (yaw) angular rate response of the rotorcraft shall satisfy the requirements specified in tables 3.2-13 and 3.2-14. The parameters specified in Tables 3.2-13 and 3.2-14 are measured from time histories of roll (yaw) rate in response to a step force command to the lateral cyclic (rudder pedal) controller. The parameters are define in 3.1.2.1. The effective time delay and response time shall be less than the magnitudes specified in the tables, however, the roll rate response time should not be less than 0.20 sec for Level 1.

Table 3.2-13
EFFECTIVE TIME DELAY IN ANGULAR RATE (SECONDS)

Flight Phase Category	Level					
	1		2		3	
	Roll	Yaw	Roll	Yaw	Roll	Yaw
XIX	.10	.15	.15	.20	.25	.30
X0X	.15	.20	.20	.25	.25	.30

Table 3.2.14
ROLL RATE RESPONSE TIME (SECONDS)

Flight Phase Category	Level		
	1	2	3
XIX	.8	1.0	-
X0X	1.0	1.5	-

3.2.11 Target tracking

When target tracking and weapon delivery is a mission requirement, Flight Phase Category XXI, the dynamics of the rotorcraft, the target tracking system and the weapon systems must be integrated to achieve the mission objectives. Appropriate consideration must be given to target acquisition and target tracking.

3.2.12 Lateral-directional control in unaccelerated flight

The capability to obtain steady flight throughout the Service Flight Envelope associated with each Flight Phase in the Forward Flight Region shall not be limited by the effectiveness of the lateral or the directional control or controls.

3.2.13 Lateral control effectiveness in maneuvering flight

The time to change bank angle by 30 degrees (t_{30}) to the right or left from a trimmed zero-roll-rate condition shall not exceed the value specified in Table 3.2-15. The time shall be measured from the initiation of roll control force application. Yaw control may be used to reduce sideslip that retards roll rate (not to produce sideslip that augments roll rate), provided that yaw control inputs are simple, easily coordinated with roll control inputs, and are consistent with piloting techniques for the aircraft in its mission. Roll control shall be sufficiently effective, in combination with other normal means of control, to balance the rotorcraft laterally throughout the Service Flight Envelope in the atmospheric environments of 3.9.

Table 3.2-15
LATERAL CONTROL EFFECTIVENESS
TIME TO CHANGE BANK ANGLE BY 30 DEGREES (SECONDS)

Flight Phase Category	t_{30}		
	Level 1	Level 2	Level 3
IXX	1.0	1.3	2.0
OXX	2.5	3.2	4.0

3.2.14 Directional control effectiveness-steady sideslips

The directional control shall be capable of establishing steady sideslip angles equal to or greater than the magnitudes specified in Table 3.2-16 unless structural loads require limiting sideslip to lesser magnitudes.

Table 3.2-16
DIRECTIONAL CONTROL EFFECTIVENESS - SIDESLIP

Flight Phase Category	Steady Sideslip (Degrees)		
	Level 1	Level 2	Level 3
IXX	$\sin^{-1} 35/V_T$	$\sin^{-1} 15/V_T$	$\sin^{-1} 10/V_T$
OXX	$\sin^{-1} 15/V_T$	$\sin^{-1} 15/V_T$	$\sin^{-1} 10/V_T$

where V_T is forward true airspeed in knots

3.2.15 Directional control effectiveness - yaw attitude change

The yaw attitude change within the first second following a step command from the rudder pedals shall not be less than the magnitudes specified in Table 3.2-17. This requirement applies with all other controllers fixed.

Table 3.2-17
DIRECTIONAL CONTROL EFFECTIVENESS - YAW ATTITUDE

Flight Phase Category	Yaw Attitude within one Second (degrees)		
	Level 1	Level 2	Level 3
IXX	6	3	1
OXX	3	3	1

3.2.16 Linearity of response to lateral-directional controllers

There shall be no objectionable nonlinearities in the variation of bank angle (yaw angle) change in a given time with lateral (directional) controller displacement or force. The magnitudes of the responses to the left and to the right shall be nearly equal for controller commands of the same magnitude in either direction from trim.

3.2.17 Lateral-directional control forces

The lateral cyclic control force required to obtain the rolling performance specified in table 3.2-15 and the rudder pedal force required to obtain the steady side slip response specified in Table 3.2-15 and the yaw attitude change specified in Table 3.2-16 shall lie between the maximums and minimums specified in Table 3.2-18.

Table 3.2.18
LATERAL-DIRECTIONAL CONTROL FORCES (POUNDS)

	Level 1		Level 2		Level 3	
	Lateral	Directional	Lateral	Directional	Lateral	Directional
Maximum	15	70	20	90	25	115
Minimum	3.3	20	3.0	18	0.5	3

3.2.18 Lateral control sensitivity

The response of the rotorcraft to commands from the lateral controller shall not be so high that the roll accelerations and lateral accelerations at the cockpit are objectionable or cause a tendency for the pilot to over control or inadvertently couple with the rotorcraft response.

3.2.19 Lateral-directional trim variation with power or collective

The rotorcraft shall not exhibit excessive lateral or directional trim changes when engine power or collective pitch, or both, are varied. Specifically, when starting from trim at any combination of power and airspeed within the operational flight envelope of the rotorcraft, it shall be possible to maintain lateral and directional trim with control displacements from the initial trim positions of no more than 2.0 inches as the engine power or collective-pitch, or both, are varied either slowly or rapidly in either direction throughout the available range.

3.2.20 Directional control with asymmetric loading

With the aircraft initially trimmed directionally with any asymmetric loading specified in the contract at any speed in the Operational Flight Envelope, it shall be possible to maintain a straight path throughout the Operational Flight Envelope with rudder pedal control forces not exceeding the maximums specified in Table 3.2-17 without retrimming.

3.2.21 Control of sideslip in rolls

In the rolling maneuvers described in 3.2.13, directional control effectiveness shall be adequate to maintain the initial trim value of sideslip with rudder pedal forces not exceeding the maximums in Table 3.2-17. This requirement applies to rolling maneuvers of magnitude up to the required roll performance of 3.2.13. For inputs smaller than those required to meet the roll performance requirements of 3.2.13, the resultant forces shall be divided by the ratio of the bank angle obtained at the time specified in 3.2.13 to the bank angle required, and the results compared with the limits of Table 3.2.17 for compliance.

3.2.22 Turn coordination

With the rotorcraft trimmed for zero bank angle straight flight, it shall be possible to maintain steady coordinated turns in either direction using the bank angle required for a standard rate (3 deg/sec) turn with rudder pedal forces not exceeding 15 pounds and with lateral cyclic control force not exceeding 2 pounds. These requirements shall apply for Level 1 and Level 2.

3.2.23 Rudder pedal induced roll

For Levels 1 and 2 the application of right rudder pedal displacement and force shall not result in left rolls and the application of left rudder pedal displacement and force shall not result in right rolls.

3.2.24 Turns without use of rudder pedal

When trimmed at any speed in the Operational Flight Envelope, it shall be possible to make sustained turns through 360 degree both to the left and to the right by use of the cyclic controller alone. These turns shall be possible with the rudder pedals held fixed and with the rudder pedals free.

3.2.25 Bank angle and roll rate oscillations

The values of the parameter sets $[\phi_{OSC}/\phi_1, \psi_{\phi IMPULSE}]$ and $(P_{OSC}/P_1, \psi_{PSTEP})$ following a [lateral cyclic impulse with rudder pedal free] (lateral cyclic step with rudder pedal fixed) shall be within the limits in Figure 3.2-1 for Level 1 and Level 2. For all levels, the change in bank angle shall always be in the direction of the lateral cyclic command. The lateral cyclic impulse shall be as abrupt as practical. The roll rate oscillation requirement shall apply for lateral cyclic step inputs up to the magnitude which causes a 40 degree bank angle change in $1.7 T_D$ seconds. These requirements shall apply to any trim condition within the Service Flight Envelope.

3.2.26 Sideslip excursions. The amount of sideslip (rate of change of sideslip) following a lateral cyclic [impulse] (step) command with rudder pedal [free] (fixed) shall be within the limits on Figure 3.2-2 for Level 1 and Level 2. The lateral cyclic impulse shall be as abrupt as practical. The requirement shall apply for step lateral cyclic commands up to the magnitude which causes a 40 degree bank angle change in T_D seconds. These requirements shall apply to any trim condition within the Service Flight Envelope.

3.3 ACCELERATING AND DECELERATING TRANSITIONS

3.3.1 Accelerating and decelerating capability

With the rotorcraft trimmed for steady flight in ground effect at any point in any Operational Flight Envelope associated with the Hover and Low Speed Flight Region it shall be possible to accelerate rapidly and safely using maximum continuous power to any point in any Operational Flight Envelope associated with the Forward Flight Region. With the rotorcraft trimmed for steady flight at any point in

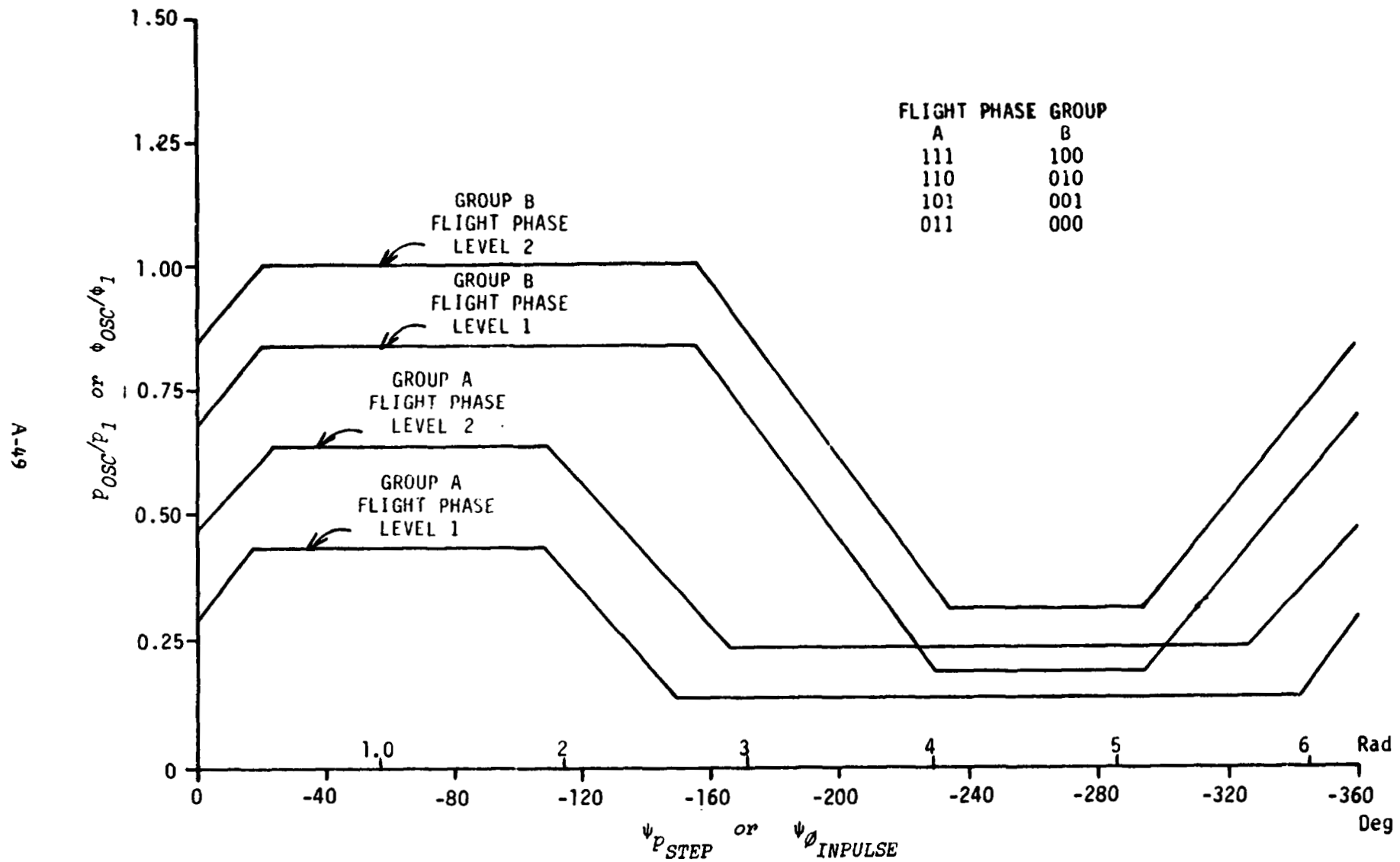

Figure 3.2-1. ROLL RATE AND BANK ANGLE OSCILLATION LIMITATIONS

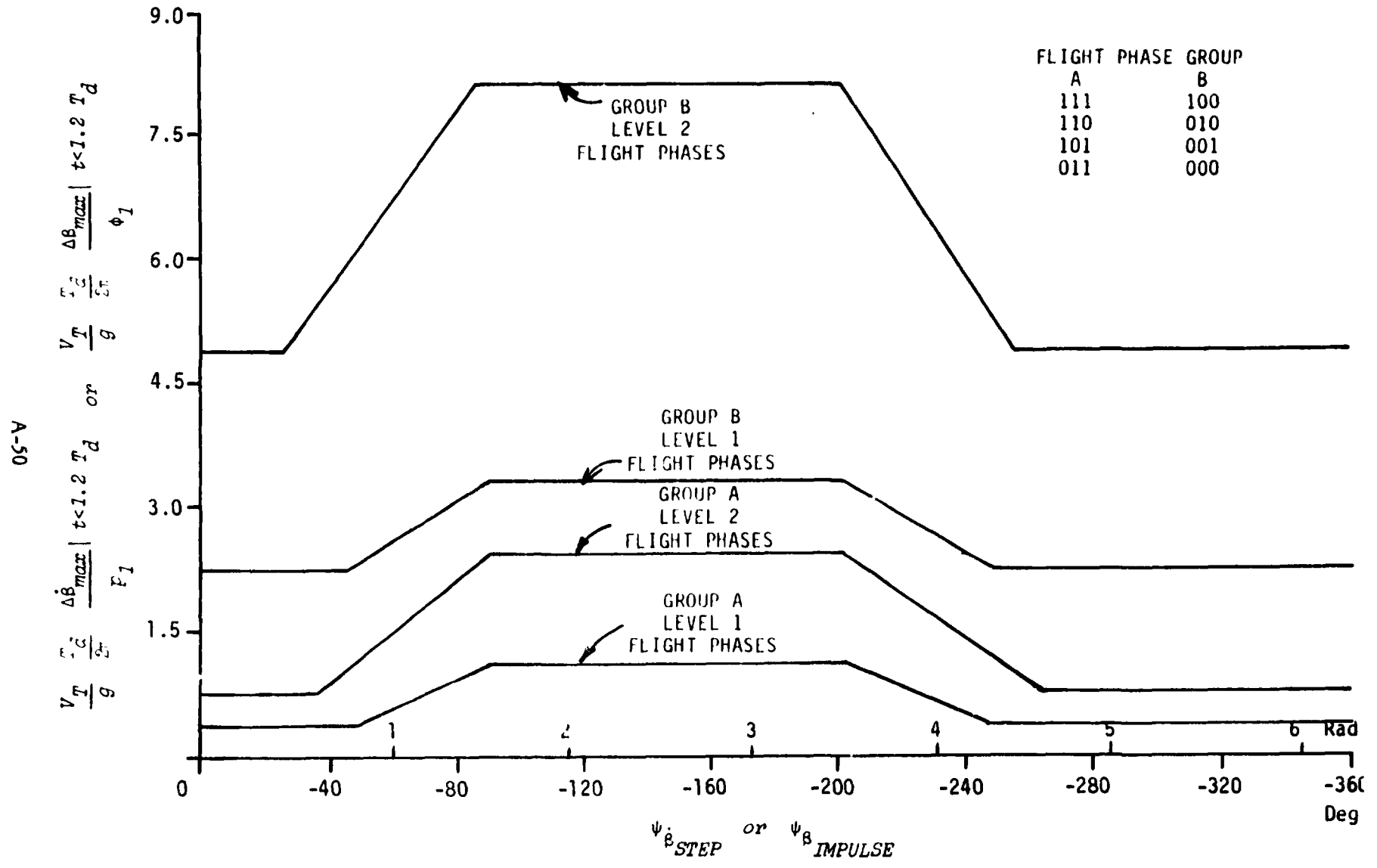

Figure 3.2-2. SIDESLIP EXCURSION LIMITATIONS

any Operational Flight Envelope associated with the Forward Flight Region it shall be possible to decelerate rapidly and safely to any point in ground effect in any Operational Flight Envelope associated with the Hover and Low Speed Flight Region.

3.3.2 Operating restrictions

It shall be possible to execute the maneuvers of 3.3.1 without restriction from factors such as longitudinal, lateral or directional control power, operation of trimming devices or surfaces, shaking, vibration, rotor rpm variations, thrust response, torque limits, control law variations, control system gain schedules etc. All controls required to perform the maneuvers shall be easily operated by one pilot.

3.3.3 Flexibility of operation

At any time during the maneuvers of 3.3.1, it shall be possible for the pilot to quickly and safely stop the acceleration and to reverse its direction.

3.3.4 Control manipulations required for accelerations/decelerations

The variations in lateral cyclic and rudder pedal control shall be minimal during the maneuvers of 3.3.1. Collective, power, and thrust control manipulations shall not result in an objectionable pilot workload.

3.3.5 Control margins

The margin of control power remaining at any stage in the accelerating/decelerating maneuvers of 3.3.1 shall not be less than that specified in Table 3.1-8 for speeds within the Hover and Low Speed Flight Region and shall not be less than that specified in Tables 3.2-14 and 3.2-16 for speeds within the Forward Flight Region.

3.3.6 Control displacements and forces

It shall be possible to perform the acceleration/deceleration maneuvers of 3.3.1 with control displacements and control forces not exceeding those specified in Table 3.1-13. Use of trim controllers is permitted.

3.3.7 Control force variations

Control force variations occurring in any five second period during the accelerating/decelerating maneuvers of 3.3.1 during which the trim controllers are not used shall not exceed the limits specified in Table 3.3-1.

Table 3.3-1
CONTROL FORCE VARIATIONS (POUNDS)

Controller	Level 1	Level 2	Level 3
Longitudinal cyclic	10	20	30
Lateral cyclic	5	10	15
Rudder Pedal	25	50	75
Collective	10	20	30
Power	2	5	7

3.4 AUTOROTATION

3.4.1 Autorotation Capability

The rotorcraft shall be capable of safely entering into partial power and power OFF autorotation at any point in the Service Flight Envelopes associated with the Hover and Low Speed Region and the Forward Flight Region at all power settings and normal states required by the operational missions and all failure states. It shall be possible to make the transition from powered flight to autorotation under the following conditions.

3.4.1.1 Multiengine rotorcraft. Multiengine rotorcraft shall be capable of entering into power OFF autorotation following simultaneous failure of all engines in climbing flight at the airspeed for best rate of climb at all power settings and any loading required by the operational missions or resulting from failure states.

3.4.1.2 Failure of engine developing highest power. The capability exists for multiengine rotorcraft to conduct flight with the engines mismatched in power output, therefore, the following requirements shall apply following failure of the engine developing the highest power.

3.4.1.3 Pilot reaction delay. For all flight conditions except simultaneous failure of multiple engines during climb, initiation of the necessary manual control motion shall be delayed by either the engine failure warning subsystem reaction time plus 1.0 second for all controls, or shall be delayed by 2.0 seconds for collective pitch control and 1.0 second for all other controls, whichever occurs first. Following simultaneous failure of multiple engines in climb, initiation of the necessary control motions shall be permitted with 0.5 second delay time.

3.4.1.4 Attitude changes from initial conditions. Assuming the pilot reaction delays specified in 3.4.1.3, engine failures and autorotational flight entry shall not result in pitch, roll or yaw attitude changes from the conditions existing at the start of the engine failure that are larger than the limits specified in Table 3.4-1.

Table 3.4-1

ATTITUDE CHANGES FOLLOWING ENGINE FAILURE (DEGREES)

Level	Pitch	Roll	Yaw $V < V_{Min R/D}$	Yaw $V > V_{Min R/D}$
1	5°	5°	10°	5°
2	10°	10°	10°	10°
3	15°	15°	30°	15°

3.4.1.5 Altitude loss. At speeds between 50 KCAS and the limit airspeed, the allowable altitude loss occurring previous to any collective control command by the pilot for recovery shall be no more than 50 feet from the extension of the initial flight path.

3.4.1.6 Rotor RPM drop. At no time during autorotation entry shall the rotor speed fall below a safe minimum transient autorotative value, as distinct from the minimum power OFF autorotative steady-state RPM.

3.4.1.7 Control margins. The margin of control power remaining at any time during autorotation entry and steady state autorotation shall not be less than that

specified in Table 3.1-8 for speeds within the Hover and Low Speed Region and shall not be less than that specified in Tables 3.2-14 and 3.2-16 for speeds within the Forward Flight Region.

3.4.1.8 Control force variations. Control force variations during the transition from powered flight to autorotative flight shall not exceed the maximums specified in Table 3.3-1.

3.4.1.9 Rotor speed control in autorotation. During unaccelerated autorotational flight, the pilot shall be able to maintain rotor speed between the upper and lower power OFF autorotational limits. This requirement must be met within the operational envelope and loading envelope without special rigging modifications in the collective control and main rotor blade angle relationship.

3.4.1.10 Dynamic Stability in steady autorotation. The longitudinal, lateral and directional dynamic stability requirements of either 3.1 or 3.2 shall apply in autorotation depending on the airspeed.

3.5 GROUND HANDLING, TAKEOFF AND LANDING

3.5.1 Starting and stopping rotor

It shall be possible while on the ground or other landing surface to start and stop the rotor blades in the environment specified in 3.9 with the wind from the most critical azimuth relative to the nose of the rotorcraft.

3.5.2 Holding ground position

It shall be possible without wheel chocks to maintain a fixed position on a level paved surface with normal rotor speed, prior to lift-off. This requirement applies for all normal states and those failure states for which take-off capability is required. The requirement applies throughout the ranges of altitude and temperature for which operation is required and in the environmental conditions specified in Section 3.9.

3.5.3 Holding deck position on moving ship. It shall be possible, with the aid of hold-down devices, to maintain a fixed position on the deck of a ship at sea in the sea state and wind environment specified in 3.9 with normal rotor speed, prior to lift-off.

3.5.4 Ground handling. It shall be possible to perform all required maneuvers including, taxiing and pivoting, without damage to rotor stops and without contact between the main rotor or tail rotor blades and any part of the helicopter structure.

3.5.5 Directional Control on the ground. Directional control shall be sufficiently powerful that its use in conjunction with other controls will permit rotorcraft equipped with wheel landing gear to perform required taxiing maneuvers at all allowable rotor speeds. The following ground handling conditions shall be met with the cyclic controller in the position required for maintaining the desired taxi speed.

3.5.5.1 Maintain straight path. It shall be possible, without the use of brakes, to maintain a straight taxi path in the ground operating environment specified in 3.9 with the wind from any direction relative to the nose of the rotorcraft.

3.5.5.2 Turns through 360°. It shall be possible to make 360 degree turns in either direction by pivoting on either main landing gear in the winds specified in 3.9.

3.5.6 Vertical Takeoff and Landing Capability

The rotorcraft shall be capable of making satisfactory vertical takeoffs and vertical landings in the environments defined in 3.9.

3.5.7 Running Takeoffs

From a level paved surface, it shall be possible to make satisfactory, safe running takeoffs up to ground speeds of at least 45 KT.

3.5.8 Landing from autorotation

It shall be possible to repeatedly make safe, power OFF, autorotational landings at speeds of 15 KTAS, or less. This capability is required in calm air at design gross weight (less jettisonable stores) at 4000 feet in 35°C air temperature at the end of a stabilized autorotational descent.

3.5.9 Control effectiveness in takeoff

The effectiveness of the longitudinal, lateral and directional controls shall not restrict the takeoff performance of the rotorcraft and shall be sufficient to prevent over-rotation to undesirable attitudes following lift-off or while in ground effect over uneven surfaces.

3.5.10 Control effectiveness in landing

The effectiveness of the longitudinal, lateral and directional controls shall not restrict the landing performance of the rotorcraft and shall be sufficient to perform flare maneuvers, required for autorotational or running landings, and to control the rotorcraft when in flight over uneven surfaces.

3.5.11 Control force limits in takeoff and landing

With the trim setting optional but fixed, the control forces required for takeoff or for landing shall not exceed one half the limits specified in Table 3.3-1.

3.6 FLIGHT CONTROL SYSTEM

3.6.1 Controller freeplay and dead zone

The free play and dead zone associated with each controller shall not result in objectionable flight characteristics. Free play is defined as controller displacement that is not resisted by control system inertia, damping, friction or spring forces. Dead zone is defined as controller displacement that does not cause displacement of the control surface in flight.

3.6.2 Control centering and breakout forces

The longitudinal and lateral cyclic controller should exhibit positive centering in flight at any normal trim setting. The rudder pedal controller should exhibit positive centering in the Forward Flight Region. Although absolute centering is not required, the combined effects of centering, breakout force, stability and force gradient shall not produce objectionable flight characteristics, such as poor tracking or permit large departures from trim conditions with controllers free. Breakout forces, including friction, preload, etc., shall be within the limits specified in Table 3.6-1. The limit values refer to controller force required to start movement of the control surface in flight.

Table 3.6-1
LIMIT CONTROL FORCES FOR BREAKOUT
INCLUDING FRICTION (POUNDS)

Controller	Level 1		Level 2		Level 3
	Min.	Max.	Min.	Max.	Max.
Longitudinal cyclic	0.5	1.5	0.5	3	5
Lateral cyclic	0.5	1.5	0.5	3	4
Rudder Pedals	*3.0	7.0	*3.0	14	20
Collective	*1.0	3.0	*1.0	6	10

*May be measured with adjustable function set.

3.6.3 Controller force-displacement gradients in the Hover and Low Speed Flight Region

The force-displacement gradients of the cockpit controllers shall be within the range specified in Table 3.6-2 throughout the Service Flight Envelope associated with Flight Phases in the Hover and Low Speed Flight Region. In addition, the gradient near trim shall be such that the total force required to produce one inch of controller displacement shall not be less than twice the breakout force. For the remaining travel, the local gradients shall not change by more than 50 percent in one inch of travel.

Table 3.6-2
CONTROLLER FORCE-DISPLACEMENT GRADIENTS
FOR HOVER AND LOW SPEED (POUNDS PER INCH)

Controller	Level 1		Level 2		Level 3
	Min.	Max.	Min.	Max.	Max.
Longitudinal Cyclic	0.5	3.0	0.5	5	8
Lateral Cyclic	0.5	2.0	0.5	4	6
Rudder Pedals	2.0	7.0	2.0	14	21

3.6.4 Adjustment of controllers

The cyclic and collective cockpit controls need not be adjustable. The pedals shall be adjustable and the control characteristics which are defined in 3.6.1, 3.6.2 and 3.6.3 shall refer to the median adjustment. A force referred to any other adjustment shall not differ by more than 10 percent from the force at the median adjustment.

3.6.5 Rate of control displacement

The ability of the rotorcraft to operate in the turbulence environment specified in 3.9 and to perform the maneuvers required by the operational missions shall not be limited by the rates of control deflection or operation of auxiliary control devices nor shall the rates of operation of either primary controls or auxiliary devices result in objectionable flight characteristics.

3.6.6 Mechanical cross-coupling

Displacement of one cockpit controller shall not produce objectionable forces or displacements at any of the other cockpit controllers.

3.6.7 Dynamic characteristics

The controller deflection shall not lead the applied control force for any frequency or force amplitude. Time delay and lag in the command channels from the

longitudinal cyclic, lateral cyclic, rudder pedal and collective controllers to the rotorcraft control surfaces shall be kept to a minimum to prevent degraded flying qualities and pilot induced oscillations. The requirements in 3.1.2.1, 3.2.2.2 and 3.2.10.1 shall apply.

3.6.8 Control system damping

All control system oscillations shall be well damped, unless they are of such an amplitude, frequency, or phasing that the cockpit-controller or airframe oscillations resulting from abrupt maneuvers or flight in atmospheric disturbances are compatible with the required level of flying qualities as determined in 2.4.

3.6.9 Augmentation systems

Normal operation of stability augmentation and control augmentation systems and devices shall not introduce any objectionable flight or ground handling characteristics.

3.6.10 Performance of augmentation systems

Any degradation of the performance of augmentation systems during flight in a severe atmospheric disturbance environment consistent with the operational mission or because of structural vibrations, shall be taken into account in demonstrating compliance with the required Level of flying qualities. In addition, any limits on the authority of augmentation systems or saturation of equipment shall not produce flying characteristics inconsistent with the required Level of flying qualities.

3.6.11 Flight Control System Failures

Special provisions shall be incorporated to preclude any critical single failure of the flight control system including trim devices or stability augmentation system which may result in flying qualities which are dangerous or intolerable. Failure-induced transient motions and trim changes resulting either immediately after failure or upon subsequent transfer to alternate control modes shall be small and gradual enough that dangerous flying qualities will not result. In addition, the crew member concerned shall be provided with immediate and easily interpreted indications whenever failures occur in the flight control system.

3.6.12 Control force to suppress transients

Without retrimming, the cockpit control forces required to suppress transients following a failure in any part of the flight control system shall not exceed one-half the Level 1 limit control force values in Table 3.3-1.

3.6.13 Transients and trim changes

This requirement applies to all Rotorcraft State changes made under conditions representative of operational procedure by activation of the rotorcraft State selectors and controls available to the pilot. With the rotorcraft initially trimmed at a fixed operating point, the peak pitch, roll, and yaw control forces required to suppress the transient rotorcraft motions resulting from the change and to maintain the desired heading, attitude, altitude, rate of climb or descent, or speed without use of the trimmer control, shall not exceed one-third of the appropriate limit control force in Table 3.3-1. This applies for a time interval of at least 5 seconds following completion of the pilot action initiating the change. The magnitude and rate of trim change after this period shall be such that the forces can be trimmed as required in 3.6.15. There shall be no objectionable buffeting or oscillations of the control device during the change.

3.6.14 Transfer to alternate control modes

The transients and trim changes caused by the intentional engagement or disengagement of any portion of the flight control system consistent with normal service use, such as selection of a particular augmentation mode, shall not exceed the following limits for at least 2 seconds following the transfer. These limits apply for controls free in the Operational Flight Envelope; $\pm 0.1g$ normal or $\pm 0.05g$ lateral acceleration ± 3 degrees per second roll rate.

3.6.15 Trim system

At all steady flight conditions within the Operational Flight Envelope, the trimming devices shall be capable of reducing the pitch, roll, and yaw control forces to zero for Levels 1 and 2. At all steady flight conditions within the Service Flight Envelope, the untrimmable cockpit control forces shall not exceed 10 pounds pitch, 5 pounds roll, and 20 pounds yaw. For Level 3, the untrimmed cockpit control forces

shall not exceed 10 pounds pitch, 5 pounds roll, and 20 pounds yaw. The failures to be considered in applying the Level 2 and 3 requirements shall include trim sticking and runaway in either direction. It is permissible to meet the Level 2 and 3 requirements by providing the pilot with alternate trim mechanisms or override capability.

3.6.16 Rate of trim operation

Trim devices shall operate rapidly enough to enable the pilot to maintain the pitch and roll control forces less than one-third of the appropriate limit forces in Table 3.3-1 during any maneuver consistent with service use, but not ever to operate so rapidly as to cause oversensitivity or trim precision difficulties. There shall be no uncommanded control oscillations or abrupt movements following and during activation or deactivation of the force trim device. Stick "jump" when trim is actuated is unacceptable.

3.6.17 Trim system irreversibility

All trimming devices shall maintain a given setting indefinitely unless changed by the pilot, by a special automatic interconnect, or by the operation of an augmentation device. If an automatic interconnect or augmentation device is used in conjunction with a trim device, provision shall be made to ensure the accurate return of the device to its initial trim position on completion of each interconnect or augmentation operation.

3.6.18 Collective irreversibility

The collective controller shall not tend to vary from its trim position under any operating conditions.

3.7 SPECIFIC FAILURES

3.7.1 General

No single failure of any component or system shall result in dangerous or intolerable flying qualities, Special Failure States 2.1.5.4 are excepted.

3.7.2 Failure Warnings

The crew members concerned shall be provided with immediate and easily interpreted indications whenever failures occur that require or limit any flight-crew action or decision.

3.7.3 Loss of tail rotor thrust

Loss of tail rotor thrust with the rotorcraft operating at the most critical combination of airspeed, gross weight and center of gravity shall not cause the rotorcraft to pitch or roll uncontrollably and it shall be possible to perform a safe power OFF landing at a touchdown speed no greater than 35 KTAS, on a paved surface, without exceeding a sideward drift of 6 KTAS at sea level standard day conditions.

3.7.4 Engine and primary electrical failure. Total engine failure, primary electrical subsystem failure, or both, shall not result in loss of flight control system operation.

3.8 MISCELLANEOUS REQUIREMENTS

3.8.1 Approach to dangerous flight conditions

If dangerous conditions exist where the rotorcraft should not be flown, it shall be possible by clearly discernable means for the pilot to recognize the approach to the impending dangers and to take preventive action. Final determination of the adequacy of all warning of impending dangerous flight conditions will be made by the procuring activity, considering functional effectiveness and reliability. Devices may be used to prevent entry to dangerous conditions only if the criteria for their design, and the specific devices, are approved by the procuring activity.

3.8.2 Warning and indication

Warning or indication of approach to a dangerous condition shall be clear and unambiguous. If a warning or indication device is required, functional failure of the device shall be indicated to the pilot.

3.8.3 Prevention of dangerous conditions

Dangerous-condition-prevention devices shall perform their designated function whenever needed, but shall not limit flight in the Operational Flight Envelope. Hazardous operation of these devices, normal or inadvertent, shall never be possible. For Level 1 and 2, neither hazardous nor nuisance operation shall be possible. For Level 3, hazardous inadvertent operation shall not be possible.

3.8.4 Pilot Induced Oscillations

There shall be no tendency for a sustained or uncontrollable oscillation resulting from efforts of the pilot to maintain steady flight or to perform the maneuvers required by the Flight Phase.

3.8.5 Residual Oscillations

The rotorcraft and control systems shall be free of residual oscillations and limit cycle oscillations for Level 1. Small amplitude residual oscillations and limit cycles are permitted for Level 2 provided the oscillations do not inhibit performing tasks required for the Flight Phase. Residual oscillations and limit cycles are permitted for Level 3 provided flight safety is not affected by the oscillations.

3.8.6 Buffet

Within the boundaries of the Operational Flight Envelope, there shall be no objectionable buffet which might detract from the effectiveness of the rotorcraft in executing its intended missions.

3.8.7 Release of stores

The intentional release of any stores shall not result in objectionable flight characteristics for Levels 1 and 2. Moreover, the intentional release of stores shall never result in dangerous or intolerable flight characteristics. This requirement applies for all flight conditions and store loadings at which normal or emergency store release is structurally permissible.

3.8.8 Effects of armament delivery and special equipment

Operation of movable parts such as bomb bay doors, cargo doors, armament pods, refueling devices, rescue equipment, or firing of weapons, release of bombs, or delivery or pickup of cargo shall not cause buffet, trim changes, or other characteristics which impair the tactical effectiveness of the aircraft under any pertinent flight condition. These requirements shall be met for Levels 1 and 2.

3.8.9 Cross-coupled effects

Control inputs or rotorcraft motions about a given rotorcraft axis shall not induce objectionable control forces or rotorcraft motions about any other axis. The ratio of the maximum amplitude of roll rate (pitch rate) to pitch rate (roll rate) following a rapid longitudinal (lateral) control command shall satisfy the requirements of Table 3.8-1 for at least 3 seconds following initiation of the control input.

Table 3.8-1
PITCH-ROLL ANGULAR RATE COUPLING RATIOS

Flight Phase Category	Maximum ratio less than		
	Level 1	Level 2	Level 3
XIX	0.3	0.5	1.0
X0X	0.5	0.7	1.0

3.8.10 Gyroscopic effects

Gyroscopic moments caused by rotating components shall not result in objectionable flight or ground handling characteristics. In flight, the elimination of the cross-coupled response during the maneuvers required to demonstrate compliance with this specification shall require less than 10 percent of the maximum control moment available about the cross-coupling axis for Level 1, and less than 20 percent for Level 2.

3.8.11 Inertial and aerodynamic cross-coupling

The application of any cockpit control input necessary to meet any pitch, roll or yaw performance requirement of this specification shall not result in any objectionable rotorcraft attitudes or angular rates about the axes not under consideration. In addition, undesired changes shall be minimal.

3.8.12 Vibration characteristics

Throughout the Operational Flight Envelope, the aircraft shall be free of objectionable shake, vibration, or roughness. In addition, throughout the Operational Flight Envelope the aircraft shall not exhibit mechanical or aeroelastic instabilities (i.e., ground resonance, flutter, etc.) that degrade the flying qualities.

3.9 ENVIRONMENTAL CONDITIONS

Unless otherwise specified by the procuring activity for a specific procurement, the environmental conditions defined in this section describe the environments in which the rotorcraft must be designed to operate. These environmental conditions will be used to evaluate the flying qualities through analysis, simulation and flight test.

3.9.1 Continuous turbulence models

Two model forms for describing continuous random turbulence are defined. Either model may be used in the process of designing and evaluating the rotorcraft flying qualities. The von Karman form of the spectra for the turbulence velocities is:

$$\begin{aligned} \phi_{u_f}(\Omega) &= \sigma_u^2 \frac{2L_u}{\pi} \frac{1}{[1 + (1.339 L_u \Omega)^2]^{5/6}} \\ \phi_{v_f}(\Omega) &= \sigma_v^2 \frac{2L_v}{\pi} \frac{1 + 8/3(2.678 L_v \Omega)^2}{[1 + (2.578 L_v \Omega)^2]^{11/6}} \\ \phi_{w_f}(\Omega) &= \sigma_w^2 \frac{2L_w}{\pi} \frac{1 + 3/3(2.678 L_w \Omega)^2}{[1 + (2.578 L_w \Omega)^2]^{11/6}} \end{aligned}$$

The Dryden form of the spectra for the turbulence velocities is:

$$\phi_{u_g}(\Omega) = \sigma_u^2 \frac{2L_u}{\pi} \frac{1}{1 + (L_u \Omega)^2}$$

$$\phi_{v_g}(\Omega) = \sigma_v^2 \frac{2L_v}{\pi} \frac{1 + 12(L_v \Omega)^2}{[1 + 4(L_v \Omega)^2]^2}$$

$$\phi_{w_g}(\Omega) = \sigma_w^2 \frac{2L_w}{\pi} \frac{1 + 12(L_w \Omega)^2}{[1 + 4(L_w \Omega)^2]^2}$$

where: $\Omega = \omega/V_T$ and V_T is True Airspeed but not less than 35 Knots

3.9.1.1 Scale lengths. The scale lengths for use in the continuous random turbulence models of 3.9.1 are defined as functions of altitude.

von Karman Model

Above $h = 2500$ ft $L_u = 2 L_v = 2 L_w = 2500$ feet

Below $h = 2500$ ft $L_u = 2 L_v = 184 h^{1/3}$ feet

$2 L_w = h$ feet

Dryden Model

Above $h = 1750$ ft $L_u = 2 L_v = 2 L_w = 1750$ feet

Below $h = 1750$ ft $L_u = 2 L_v = 145 h^{1/3}$ feet

$2 L_w = h$ feet

3.9.1.2 RMS intensities. The root-mean-square intensities $\sigma_u = \sigma_v$ to be used in the continuous random turbulence models of 3.9.1 are defined in Table 3.9-1.

Table 3.9-1
 σ_u AND σ_v INTENSITIES

Environment	h < 2500/1750 ft	h > 2500/1750 ft
Operational	$\sigma_u = 6$ ft/sec	$\sigma_u = 6$ ft/sec
Most Severe	$\sigma_u = 10$ ft/sec	$\sigma_u = 20$ ft/sec

The magnitude of σ_w is a function of σ_u and the scale length definitions as follows.

von Karman Model

Dryden Model

$$\frac{\sigma_u^2}{L_u^{2\beta}} = \frac{\sigma_v^2}{(2L_v)^{2\beta}} = \frac{\sigma_w^2}{(2L_w)^{2\beta}}$$

$$\frac{\sigma_u^2}{L_u} = \frac{\sigma_v^2}{2L_v} = \frac{\sigma_w^2}{2L_w}$$

Below h = 2500 ft. for the von Karman model and below h = 1750 ft. for the Dryden model, the magnitude of σ_w is a function of altitude.

von Karman Model

Dryden Model

$$\sigma_w = \frac{h^{2\beta}}{\sqrt[3]{184}} \sigma_u$$

$$\sigma_w = \frac{h^{1/3}}{\sqrt{145}} \sigma_u$$

h < 2500 feet

h < 1750 feet

3.9.1.3 Application of the disturbance model in analyses. The gust and turbulence velocities shall be applied to the rotorcraft equations of motion through the aerodynamic terms only, and the direct effect on the aerodynamic sensors shall be included when such sensors are part of the rotorcraft augmentation system. When using the discrete gust model, all significant aspects of the penetration of the gust by the rotorcraft shall be incorporated in the analyses. Application of the disturbance model depends on the range of frequencies of concern in the analyses of the rotorcraft. When structural modes are significant, the exact distribution of turbulence velocities should be considered. For this purpose, it is acceptable to consider u_g and v_g as being one-dimensional functions only of x, but w_g shall be considered two-dimensional, a function of both x and y, for the evaluation of aerodynamic forces and moments.

When structural modes are not significant, rotorcraft rigid-body responses may be evaluated by considering uniform gust or turbulence immersion along with linear gradients of the disturbance velocities. The uniform immersion is accounted for by u_g , v_g , and w_g defined at the rotorcraft center of gravity. The angular velocities due to turbulence are equivalent to the aerodynamic effect of rotorcraft angular velocities. Approximations for these angular velocities are defined (precisely at very low frequencies only) as follows:

$$- \dot{\alpha}_g = q_g = \frac{\partial w_g}{\partial x}, \quad p_g = - \frac{\partial w_g}{\partial y}, \quad r_g = - \frac{\partial v_g}{\partial x}$$

The spectra of the angular velocity disturbances due to turbulence are then given by:

$$\phi_{p_g}(\Omega) = \frac{\sigma_w^2}{L_w} \frac{0.4 \left(\frac{\pi L_w}{2b} \right)^{1/3}}{1 + \left(\frac{4b}{\pi} \Omega \right)^2}, \quad \phi_{q_g}(\Omega) = \frac{\Omega^2}{1 + \left(\frac{4b}{\pi} \Omega \right)^2} \phi_{w_g}(\Omega), \quad \phi_{r_g}(\Omega) = \frac{\Omega^2}{1 + \left(\frac{3b}{\pi} \Omega \right)^2} \phi_{v_g}(\Omega)$$

where b = wing span or the rotor diameter whichever is greater. The turbulence components, u_g , v_g , w_g , and p_g shall be considered mutually independent (uncorrelated) in a statistical sense. However, q_g is correlated with w_g , and r_g is correlated with v_g . For the discrete gusts the linear gradient gives angular velocity perturbations of the form:

$$p_g = p_m \sin \frac{\pi x}{d_m} \quad 0 \leq x \leq d_m$$

For the low-altitude model, the turbulence velocity components, u_g , v_g , and w_g are to be taken along axes with u_g aligned along the relative mean wind vector and w_g vertical.

3.9.2 Discrete gust model.

The discrete gust model may be used for any of the three gust-velocity components and, by derivation, any of the three angular components.

The discrete gust has the "1-cosine" shape given by:

$$v = 0 \quad , \quad x < 0$$

$$v = \frac{v_m}{2} \left(1 - \cos \frac{\pi x}{d_m} \right) \quad , \quad 0 \leq x \leq d_m$$

$$v = v_m \quad , \quad x > d_m$$

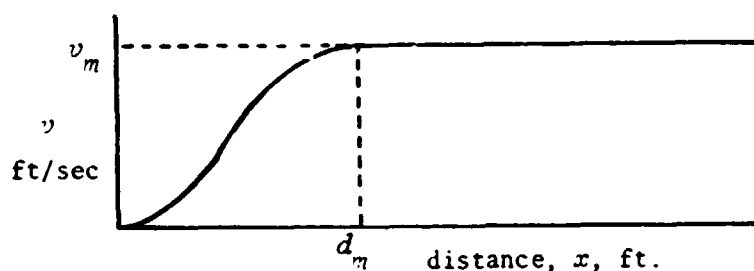

The discrete gust above may be used singly or in multiples in order to assess rotorcraft response to, or pilot control of, large disturbances. Step function or linear ramp gusts may also be used.

3.9.2.1 Gust lengths. Several values of d_m shall be used, each chosen so that the gust is tuned to each of the natural frequencies of the rotorcraft and its flight control system (higher-frequency structural modes may be excepted). For the Severe intensities, modes with wavelengths less than the turbulence scale length may be excepted.

3.9.2.2 Gust magnitudes. The gust magnitudes u_g , v_g , and w_g shall be determined from Figure 3.9-1 using values of d_m from 3.9.2.1 and values of σ_u , σ_v and σ_w from 3.9.1.2. Microbursts or downbursts, i.e. short-lived vertical downdrafts can occur at altitudes below 300 feet. These may be represented by a full (1-cos) function with $V_m = -30$ ft/sec and $d_m = 1800$ ft where d_m is horizontal distance.

3.9.3 Mean wind model

The mean wind speed variation with altitude, above the ground, is defined by the following equation

$$V_w = V_o + G h \quad 0 < h < 300 \text{ feet}$$

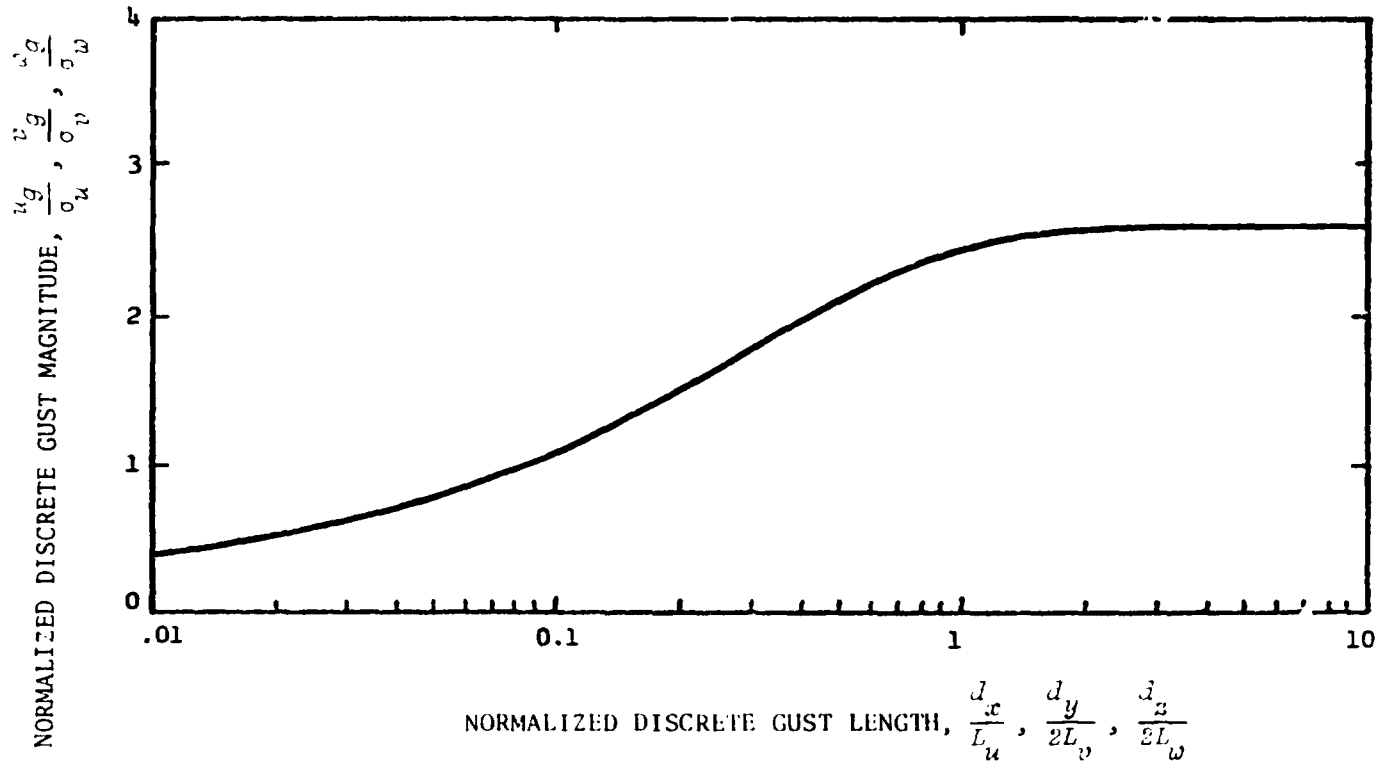

Figure 3.9-1 MAINTENANCE OF DISCRETE GUSTS

The surface wind V_0 is defined in Table 3.9-2.

Table 3.9-2
SURFACE WIND MAGNITUDE

Environment	V_0		
	Headwind	Crosswind	Tailwind
Operational	50 ft/sec	50 ft/sec	0 ft/sec
Most Severe	76 ft/sec	50 ft/sec	0 ft/sec

The wind speed is relative to the ground. The directions headwind, crosswind and tailwind refer to desired ground track. In vertical flight at zero ground speed, the wind directions refer to rotorcraft heading at zero altitude.

The wind gradient with altitude is defined in Table 3.9.2a.

Table 3.9 2a
WIND GRADIENT

Environment:	G ft/sec Per Foot
Operational	.14
Most Severe	.34

3.9.4 Tree-line wake

The mean wind speed variation with altitude in the lee of a line of closely spaced trees is defined in Figure 3.9-2. The wind direction is perpendicular to the tree line. The wind speed at 140 feet altitude is specified in Table 3.9-3.

Table 3.9-3
WIND SPEED AT 140 FT ALTITUDE

Environment	V_w at $h = 140$ ft
Operational	70 ft/sec
Most Severe	124 ft/sec

The surface wind V_0 is defined in Table 3.9-2.

Table 3.9-2
SURFACE WIND MAGNITUDE

Environment	V_0		
	Headwind	Crosswind	Tailwind
Operational	50 ft/sec	50 ft/sec	0 ft/sec
Most Severe	76 ft/sec	50 ft/sec	0 ft/sec

The wind speed is relative to the ground. The directions headwind, crosswind and tailwind refer to desired ground track. In vertical flight at zero ground speed, the wind directions refer to rotorcraft heading at zero altitude.

The wind gradient with altitude is defined in Table 3.9.2a.

Table 3.9.2a
WIND GRADIENT

Environment	G ft/sec Per Foot
Operational	.14
Most Severe	.34

3.9.4 Tree-line wake

The mean wind speed variation with altitude in the lee of a line of closely spaced trees is defined in Figure 3.9-2. The wind direction is perpendicular to the tree line. The wind speed at 140 feet altitude is specified in Table 3.9-3.

Table 3.9-3
WIND SPEED AT 140 FT ALTITUDE

Environment	V_w at $h = 140$ ft
Operational	70 ft/sec
Most Severe	124 ft/sec

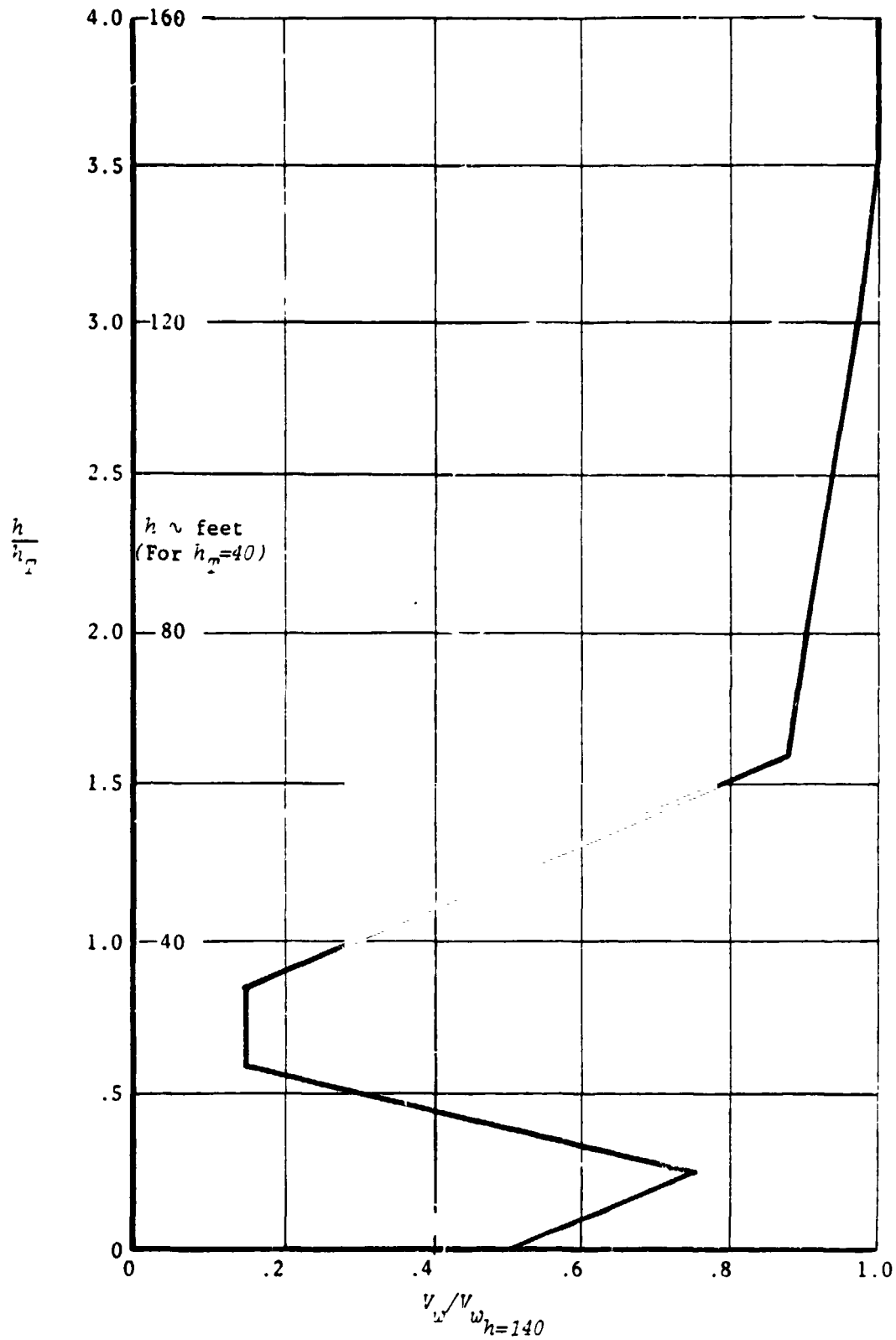

Figure 3.9-2 WIND SPEED BEHIND TREE-LINE

3.9.5 Ship airwake models

Airwake models for DD-963 and DE-1052 class ships have been defined in References 3.9-1 and 3.9-2. These airwake models, or improved versions, shall be used for design and evaluation of the flying qualities of rotorcraft required to takeoff and land on this class ship or to perform other Flight Phases in close proximity to this class ship while under way at sea. The ship airwake environment is specified in Table 3.9-4.

Table 3.9-4
SHIP AIRWAKE AND SHIP MOTION

Environment	Condition*
Operational	7-13
Most Severe	2-6

*The condition numbers refer to Table II of Reference 3.9-1.

3.9.6 Rainfall model

The rainfall rate environment is specified in Table 3.9-5.

Table 3.9-5
RAINFALL RATE ENVIRONMENT

Environment	Rainfall Rate
Operational	50 mm/Hour
Most Severe	83 mm/Hour

3.9.7 Atmospheric temperature, pressure and density

The variation of air temperature, pressure and density with altitude is specified in Table 3.9-6.

Table 3.9-6

Environment	Atmopshere
Operational	Standard
Most Severe	Army Hot Day

3.9.8 Ambient light

Ambient light conditions are defined as follows.

Day-direct bright sunlight	1 x 10 ⁴ foot candles
Night-low light level	2.5 x 10 ⁻⁴ foot candles
Dark	No light

3.9.9 Surface slope-takeoff/landing

The surface slope conditions for which the rotorcraft must be designed to perform takeoff and landing operations are specified in Table 3.9-7.

Table 3.9-7
SURFACE SLOPE-TAKEOFF/LANDING

Environment	Slope
Operational	10° All azimuth angles relative to nose
Most Severe	15° Side-to-side

3.9.10 Ship motion models

Ship motion models for the DD 963 class ship are defined in Ref. 3.9-1. These ship motion models, or improved versions, shall be used for design and evaluation of the flying qualities of rotorcraft required to takeoff and land on this class ship. The ship motion environment is specified in Table 3.9-4.

3.9.11 Flight deck environment

The flight deck configuration, size, visual landing aids and accessories of aviation facility ships defined in References 3.9-6 and 3.9-1 shall be used for design and evaluation of the flying qualities of rotorcraft required to takeoff and land on or otherwise operate in conjunction with aviation facility ships.

- 3.9-1. Fortenbaugh, R.L., "Mathematical Models for the Aircraft Operational Environment of DD-963 Class Ships," Vought Corp. 2-55800/8R-35^0 26 Sept 1978).
- 3.9-2. Fortenbaugh, R.L., "A Math Model For The Airwake of a DE-1052 Class Ship," Vought Report 2-53300/7R-3397, 13 May 1977.
- 3.9-3. St. Denis, M.; W.J. Pierson, "On the Motions of Ships in Confused Seas," Transactions of the Society of Naval Architects and Marine Engineers, Vol. 61, pp. 280-357, 1953.
- 3.9-4. Brown, R.G.; F.A. Camaratta, "NAVAIRENGCEN Ship Motion Computer Program," NAEC Report NAEC MISC-903-3, 1978.
- 3.9-5. Baitis, A.E., W.G. Meyers; T.R. Applebee, "A Non-Aviation Ship Motion Data Base for the DD 963, CG2G, FF 1052, FFG 7, and the FF 1040 Ship Classes." DTNSRDC Report STD-738-01, Dec 1976.
- 3.9-6. Anonymous, "Helicopter Facilities Bulletin No. 1C, NAEC 91122, 31 March 1976.

Appendix B

**BACKGROUND INFORMATION AND USERS GUIDE
FOR DRAFT SPECIFICATION STRUCTURE PROPOSED
FOR MIL-H-8501A REVISION**

MIL-H-8501A
TM No. 22
November 1983

**BACKGROUND INFORMATION AND USERS GUIDE
FOR DRAFT SPECIFICATION STRUCTURE
PROPOSED FOR MIL-H-8501A REVISION**

Calspan Contract No. NAS2-11303

Prepared by:

C.R. Chalk

TABLE OF CONTENTS

<u>Section</u>		<u>Page</u>
1	SPECIFICATION STRUCTURE AND PHILOSOPHY	B-5
	1.0 SCOPE AND CLASSIFICATIONS	B-6
	1.1 APPLICABILITY	B-6
	1.2 OPERATIONAL MISSIONS AND FLIGHT PHASES	B-6
	1.3 FLIGHT REGIONS	B-7
	1.3.1 Hover and Low Speed	B-8
	1.3.2 Forward Flight	B-9
	1.3.3 Accelerating and Decelerating Transition	B-9
	1.3.4 Autorotation	B-10
	1.3.5 Takeoff and Landing	B-10
	1.3.6 Ground Handling	B-10
	1.4 OPERATIONAL CAPABILITY CLASSIFICATION	B-10
	1.5 CATEGORIZATION OF FLIGHT PHASES	B-17
	1.6 LEVELS OF FLYING QUALITIES	B-30
2	DEFINITIONS AND APPLICABLE DOCUMENTS	B-33
	2.1 DEFINITION OF THE ROTORCRAFT	B-33
	2.1.1 Loadings	B-33
	2.1.2 Moments of Inertia and Products of Inertia	B-33
	2.1.3 External Stores	B-33
	2.1.4 Configurations	B-35
	2.1.5 State of the Rotorcraft	B-36
	2.1.5.1 Rotorcraft Normal States	B-36
	2.1.5.2 Rotorcraft Failure States	B-36
	2.1.5.3 Rotorcraft Specific Failure States	B-37
	2.1.5.4 Rotorcraft Special Failure States	B-37
	2.2 DEFINITION OF FLIGHT ENVELOPES	B-40
	2.2.1 Operational Flight Envelopes	B-40
	2.2.2 Service Flight Envelopes	B-40
	2.2.3 Operating Limitations	B-41
	2.3 DEFINITION OF THE ENVIRONMENT	B-47
	2.3.1 Operational Environment	B-47
	2.3.2 Most Severe Environment	B-48
	2.4 DEFINITION OF CONDITIONS FOR WHICH DEGRADED FLYING QUALITIES ARE PERMITTED	B-50
	2.4.1 Applications of Levels	B-50
	2.4.2 Requirements for Airplane Normal States	B-54
	2.4.3 Requirements for Airplane Failure States	B-55
	2.4.4 Explanatory Notes Concerning Application of Levels	B-64
	2.4.4.1 Conceptual Diagrams of the Design Evaluation Process	B-64
	2.4.4.2 Theoretical Compliance	B-64
	2.4.4.3 Definitions of Level Regions	B-65
	2.4.4.4 Computational Assumptions	B-68
	2.5 APPLICABLE DOCUMENTS	B-69

TABLE OF CONTENTS (CONT'D)

<u>Section</u>		<u>Page</u>
3	FLYING QUALITIES REQUIREMENTS FOR CLASS I	B-70
3.9	ENVIRONMENTAL CONDITIONS	B-70
3.9.1	Continuous Turbulence Models	B-71
	3.9.1.1 Scale Lengths	B-73
	3.9.1.2 RMS Intensities	B-74
	3.9.1.3 Application of the Disturbance Model In Analyses	B-82
3.9.2	Discrete Gust Model	B-84
	3.9.2.1 Gust Lengths	B-84
	3.9.2.2 Gust Magnitudes	B-84
3.9.3	Mean Wind Model	B-87
3.9.4	Tree-Line Wake	B-90
3.9.5	Ship Awake Models	B-93
3.9.6	Rainfall Model	B-96
3.9.7	Atmospheric Temperature, Pressure, and Density	B-98
3.9.8	Ambient Light	B-99
3.9.9	Surface Slope-Takeoff/Landing	B-100
3.9.10	Ship Motion Models	B-101
3.9.11	Flight Deck Environment	B-102

Section 1 SPECIFICATION STRUCTURE AND PHILOSOPHY

The structure proposed for the mission-oriented flying qualities specification for military rotorcraft is broadly similar to the structures of MIL-F-8785C and MIL-F-8330, however, there are significant differences in the classifications, categorizations and definitions which will better facilitate achieving the goal of developing mission-oriented flying qualities requirements.

The specification structure requires that the operational missions for which the rotorcraft is to be designed must be divided into segments which are identified as Flight Phases. Each Flight Phase is assigned to one of eight Flight Phase Categories on the basis of required maneuver capability, precision of space position control and whether or not target tracking is required. The Flight phases are also assigned to Operational Capability Classes on the basis of the visual conditions under which the Flight Phase is required to be performed and the number of crew members. In addition, the Flight Phases are assigned to Flight Regions on the basis of speed, acceleration, power and ground contact.

Initially, the flying qualities requirements will be separately stated for each of the four Operational Capability Classes. After the entire specification document has been drafted, the requirements for each Operational Capability Class will be reviewed to determine whether the separate sets of requirements can be combined to reduce the volume of the specification document. Within each Operational Capability Class, the requirements are separately stated for each Flight region. The Levels concept is used in the requirement statements and the individual requirements are applied to Flight Phase Categories or groups of Flight Phase Categories as appropriate for each requirement.

There are no classification categories based on mission, size, weight or configuration factors. It is believed that the flying qualities requirements should be independent of configuration factors and that the adopted structure permits adequate accommodation of size, weight and mission factors.

Definitions of Rotorcraft States are introduced along with definitions of Flight Envelopes and Operating Environments. The combinations of these factors for

which degraded flying qualities will be permitted are defined in the specification structure.

In the following paragraphs, each element of the specification structure is introduced, amplified and discussed.

Requirement

1.0 SCOPE AND CLASSIFICATIONS

DISCUSSION

This section contains the major definitions which establish the framework of the specification. Further discussion follows.

1.1 APPLICABILITY

This specification contains the requirements for the flying and ground handling qualities of U.S. military rotorcraft.

DISCUSSION

This statement identifies the general type of aircraft to which the specification is intended to apply. Rigorous definition of the term rotorcraft is not attempted. Application of the specification in specific procurements is left to the discretion of the procuring activity.

1.2 OPERATIONAL MISSIONS AND FLIGHT PHASES

The procuring activity will specify the operational missions to be considered by the contractor in designing the rotorcraft to meet the requirements of this specification. The operational missions considered should include the entire spectrum of intended operational usage. The contractor shall divide each operational mission into segments which will be identified as Flight Phases. Each Flight Phase shall be assigned to the appropriate Flight Region of 1.3, Operational Capability Classification of 1.4 and Flight Phase Category of 1.5.

DISCUSSION

The procuring activity is charged with responsibility for defining the operational missions that the contractor must consider in designing the rotorcraft. The procuring activity is advised to consider the entire spectrum of intended operational usage. Although it is often argued that it is not possible to foresee how an aircraft will be used by operational units, or, that an aircraft is seldom used for the purpose for which it is procured, these arguments do not negate the need to define the intended application so that the contractor can perform the design effort with defined goals.

The contractor is charged with responsibility for dividing each operational mission into segments that are designated as Flight Phases. The Flight Phases are defined as segments of the operational missions for which the piloting task is fairly specific and for which the rotorcraft state, operating condition and flight environment are relatively constant. The number of segments into which the operational missions should be divided is a compromise between the desire to tailor and optimize the flying qualities throughout each operational mission and the cost required to do so with consideration given to the degree of improvement that results. The intent of the Flight Phase concept is to permit writing flying qualities requirements that are specific to the piloting tasks to be accomplished and which serve to focus the design effort.

1.3 FLIGHT REGIONS

The flying and ground handling requirements of this specification are separately stated for each of the following Flight Regions.

1.3.1 Hover and Low Speed

Flight in hover or at speeds less than the speed for minimum power required. Includes forward, rearward, and sideward flight relative to the air mass.

1.3.2 Forward Flight

Forward flight at true airspeed greater than the speed for minimum power required.

1.3.3 Accelerating and Decelerating Transition

Accelerating or decelerating transitions between Hover and Low Speed and Forward Flight.

1.3.4 Autorotation

Flight with engine at Flight Idle or Failed.

1.3.5 Takeoff and Landing

Takeoff from the landing surface and return to the landing surface.

1.3.6 Ground Handling

Operation of the rotorcraft while on the ground, water or other landing surface.

DISCUSSION

By stating the flying qualities requirements separately for each of the Flight Regions defined in paragraph 1.3 it is possible to tailor the requirements and to focus the design task to consider the following factors in each Flight Region.

1.3.1 Hover and Low Speed

The degrees of freedom and controls are mainly coupled as follows in hover and low speed flight.

	CONTROLS									
	<u>u</u>	<u>w</u>	<u>q</u>	<u>v</u>	<u>p</u>	<u>r</u>	<u>Pitch</u>	<u>Coll</u>	<u>Roll</u>	<u>Yaw</u>
u	x	-	x	-	-	-	x	-	-	-
w	-	x	-	-	-	-	-	x	-	-
q	x	-	x	-	-	-	x	-	-	-
v	-	-	-	x	x	-	-	-	x	-
p	-	-	-	x	x	-	-	-	x	-
r	-	-	-	-	-	x	-	-	-	x

- The aerodynamic characteristics of the fuselage and the rotors are unique in the hover and low speed region
- Piloting tasks and control techniques are unique in the hover and low speed region.

1.3.2 Forward Flight

- In the forward flight region, the primary coupling between the degrees of freedom and controls for rotorcraft is different from hover and more similar to that of fixed wing aircraft.

	CONTROLS									
	<u>u</u>	<u>w</u>	<u>q</u>	<u>v</u>	<u>p</u>	<u>r</u>	<u>Pitch</u>	<u>Coll</u>	<u>Roll</u>	<u>Yaw</u>
u	x	x	x	-	-	-	x	x	-	-
w	x	x	x	-	-	-	x	x	-	-
q	x	x	x	-	-	-	x	x	-	-
v	-	-	-	x	x	x	-	-	x	x
p	-	-	-	x	x	x	-	-	x	x
r	-	-	-	x	x	x	-	-	x	x

- The aerodynamic characteristics of the fuselage and the rotors are different from the characteristics in hover.
- Piloting tasks and control techniques are different from the techniques used in hover.

1.3.3 Accelerating and Decelerating Transition

- The resulting speed changes cause dynamic pressure changes.
- Changes in control laws may be scheduled as speed changes occur.
- Control system gains may be scheduled with speed or dynamic pressure
- Automatic configuration changes may be scheduled to occur such as tail plane incidence changes with speed and collective setting.

1.3.4 Autorotation

- Reduced power or failed engines
- Rotor operating state
- Use of energy stored in rotor rotational state

1.3.5 Takeoff and Landing

- Landing gear loads and dynamic characteristics impose constraints and alter the dynamic system.
- Piloting task and operating constraints are unique.
- Ground effects are of significance to task performance and can be detrimental.
- Hauldown loads alter the dynamic system, impose constraints and impact the pilot control technique.

1.3.6 Ground Handling

- The control tasks and the control techniques required for operation on the ground are different from those used in flight.
- Gear loads and dynamics are involved.
- Surface conditions are of significance.

1.4 OPERATIONAL CAPABILITY CLASSIFICATION

The procuring activity will designate the conditions of external visibility in which each Flight Phase defined in 1.2 must be performed. The procuring activity will assign each Flight phase to one of the four cells of the following matrix based on whether mission requirement is for operation in the Flight Phase only when external visual cues are available to the unaided eye or whether the mission requirement is for

operation in the Flight Phase even when external visual cues are not available to the unaided eye.

External Visual Conditions in Which Operational Capability is Required	Only When Position and Velocity Cues Are Available	Even When Position and Velocity Cues are Not Available
Only when Angular Orientation Cues are Available	Class I	Class II
Even when Angular Orientation Cues are Not Available	Class III	Class IV

Class Is, IIs, IIIs, IVs designates that the rotorcraft must be designed for operation in the Flight Phase by one crewman.

DISCUSSION

Designation by the procuring activity of an Operational Capability Classification other than Class I for a Flight Phase can have a great impact on the sensors, computers, control servos, information displays, vision aids, degree of augmentation and/or automation that must be incorporated in the rotorcraft. In Tables 1.4-1 through 1.4-4, examples are given to illustrate how the Operational Capability Classification impacts the sensor, actuation and display equipment required and the degree to which it must be integrated and automated to provide the desired Operational capability.

Table 1.4-1
IMPLICATIONS OF OPERATIONAL CAPABILITY CLASSIFICATION TO
INFORMATION DISPLAYS AND STABILIZATION REQUIRED

Class I	Flight with Visual References
	Displays Status information (Airspeed, Altitude, Compass, Rotor RPM, Engine, Fuel etc.) is required.
	Guidance, Navigation, Weapon aiming as required by application.
	Stabilization Workload reduction
Class II	Flight over water, above clouds, featureless plane.
	Displays Status Information is Required
	Horizontal Situation information is required
	Accuracy depends on Flight Phase and Mission
	Stabilization Workload reduction
Class III	Flight near obstacles in low visibility
	Displays Status Information required
	Vertical Situation information is required for Task Performance. ADI
	Integrated Electronic Display Workload reduction
	Stabilization Required for some Tasks
	Command-Hold Modes Workload reduction

Table 1.4-1 (Cont.)
IMPLICATIONS OF OPERATIONAL CAPABILITY CLASSIFICATION TO
INFORMATION DISPLAYS AND STABILIZATION REQUIRED

Class IV Flight without visual references (cont.)

Displays	Vertical and Horizontal situation displays required Vision aids required for some Tasks Integrated electronic display workload reduction required for some tasks
Stabilization	Required for performance of most tasks Command-Hold modes Required for some tasks

Maximum use should be made of sensor data for controls and displays.

Table 1.4-2
EXAMPLES OF OPERATIONAL CAPABILITY CLASSIFICATION

Class I	<p>Extreme Example Army Owl Team U.S. Army Aviation Digest V20 #3 Mar. 1974</p> <p>Night NOE at Hunter Liggett Rugged terrain and tall trees Two crew, highly trained Dark adapted, high currency required OH-58 & AH-1G. No displays. No augmentation other than angular rate damper in AH-1G. Low light level 2.5×10^{-4} foot candles</p>
Class II	<p>Examples Mine sweeping, Bomb drop from above clouds, ASW search, Navigation over water or cloud deck. Guidance accuracy and display media is function of task. Augmentation alleviates workload.</p>
Class III	<p>Example Flight near ship in fog or haze and sea state, Flight near hill side in fog, HLH mission. Attitude Gyro and display or stabilization is almost "required" equip.</p>
Class IV	<p>Example Blind flight, very dark night, flash or laser shutters closed. Flight in clouds. NOE operation in dark. Automatic Terrain following. Attitude, Altitude, Speed, Guidance required. Vision Aids required for some tasks Stabilization, automation required</p>

Table 1.4-3
HOW PAST PROGRAMS AND HELICOPTERS RELATE TO THE
OPERATIONAL CAPABILITY CLASSIFICATIONS

Class I	All
Class II	<p>Depends on Flight Phase and Accuracy Required</p> <p>Cross Country above Clouds UH-1, Any helic. equipped with Nav. Aids</p> <p>Mine Sweep H-53</p> <p>ASW Search H-53, SH-2F, SH-60</p> <p>Air Rescue H-50 Nighthawk, H-53, Coast Guard Dauphine</p>
Class III	<p>Shipboard landing ASW Sonar dunk H-53, SH-2F, SH-60, SH-3</p> <p>Assult H-47, H-53</p> <p>Slung load Pickup and Deliver H-47, H-53, H-60</p>
Class IV	<p>Many jobs Assult, Attack, Cargo handling TAGS H-47, Model 347 HLH Demo., AH-64</p>
Class IVs	LHX

ORIGINAL PAGE IS
OF POOR QUALITY

Table 1.4-4
SENSORS USED IN HELICOPTER CONTROL/DISPLAY SYSTEMS

	CH-3E Loar Steg.	CH-3E Collins	CH-46 LRC	CH-46 LRC	CH-46 LRC	CH-46 LRC	SH-3 LRC	CH-47 VALT	CH-46 MIT	CH-46 MIT Digital	CH-47 CAE	347 Vertol	UH-1H Sperry Army	UH-1H Sperry Navy	CH-53 Sikorsky	I-22A
ϕ Gyro	X	?	X	X	X	X	?	X	X		X	X	X	X	X	X
θ Gyro	X	?	X	X	X	X	?	X	X		X	X	X	X	X	X
ψ Gyro	X	X	X	X	X	X	?	X	X	X	X	X	X	X	X	X
ϕ Gyro	X	X	X	X	X	X	X	X				X	X	X	X	X
θ Gyro	X	X	X	X	X	X	X	X				X	X	X	X	X
ψ	X	X	X	X	X	X	X	X				X	X	X	X	X
n_x	X				X	X		X			X			X	X	X
n_y	X			X	X	X	?	X			X			X	X	X
n_z	X			X	X	X		X						X	X	X
Airspeed	X	X	X	X	X	X	X	X	X	X	X	X	X	X	X	X
Baro. Alt.	X	X		X	X	X		X	X	X	X	X	X	X	X	X
Baro. Alt. Rate	X								X						X	
Vert. Speed			X	X	X	X										X
θ									X	X	?	X				
Radar Alt.	X		X	X	X	X	X	?			X	X	X	X	X	X
Doppler X	X	X														
Y	X	X														
Z	X	X														
ω																
Vert. Accel.				Z					X	Z	X	X				
V_H				X					X	X	X	X				
V_E				Y					X	X	X	X				
ϕ									X	X	X					
θ									X	X	X					
ψ									X	X	X					
Range									X	X	X					
DME		X												X		
TACAN	X															
Radar																
Telemeter			X	X	X	X	X	X						X		V_E
Azimuth																
VOR																
TACAN	X															
STATE	X	X														
Localizer	X	X														
MLS																
Y. Az. Telemetr.			Y	Y	Y	Y	Y	Y						X		V_E
Magnetic Elevation																X
Slide Slope MLS		X														
Z. El. Telemetry			Z	Z	Z	Z	Z	Z	Elev					Elev.		Z_E
Pitch Cyclic	X	X	X	X	X	X	X	X	X	X	X	X	X	X	X	X
Roll Cyclic	X	X	X	X	X	X	X	X	X	X	X	X	X	X	X	X
Rudder Pedal	X	X	X	X	X	X	X	X	X	X	X	X	X	X	X	X
Collective	X	X	X	X	X	X	X	X	X	X	X	X	X	X	X	X
Torque									X	X						X
Cable Angle												X				
Cable Tension												X				
Cable Length												X				
Hover Posit.												X				
Hover Vel												X				
LORAS u																X
v																X
w																X

1.5 CATEGORIZATION OF FLIGHT PHASES

The Flight Phases of 1.2 shall be characterized and categorized by the contractor subject to the approval of the procuring activity. The contractor shall characterize each Flight Phase using the following characteristics and characterizations.

CHARACTERISTICS	CHARACTERIZATIONS	
Maneuvering Required M	Rapid 1	Gradual 0
Precise* Flight Path or Space Position Control Required P	Yes 1	No 0
Target Tracking Required T	Yes 1	No 0

Flight Phase Categories are defined as the following combinations of the characterizations of the characteristics.

M	P	T	Examples
1	1	1	Ground Attack
1	1	0	Terrain Avoidance, NOE
1	0	1	Air-Air Combat With Missiles
1	0	0	Missile Avoidance
0	1	1	Hover Bob-Up & Target Acquisition
0	1	0	External Load Placement
0	0	1	Missile Launch
0	0	0	Loiter

*Quantitative definitions of precise flight path or space position control must be made by the procuring activity for certain Flight Phases in specific procurements. Examples are

- External load positioning accuracy required.
- Minimum visual range and minimum descent altitude required for approach to landing operations.

Quantitative definitions of the precision or accuracy required in specific Flight Phases will determine the accuracy of sensors and guidance systems and may influence the need for stabilization and/or gust alleviation.

DISCUSSION

There is potentially a very large number of Flight Phases that could be defined if one considers all possible operational missions. Because this is the case, it is necessary to use a characterization and categorization scheme to reduce the large number of individual Flight Phases to a smaller number of Flight Phase categories for which it may be feasible to state flying qualities requirements.

The contractor is charged with responsibility for characterizing each Flight Phase using two characterizations for each of the three characteristics called out in the table in paragraph 1.3. Eight Flight Phase Categories are defined by the various possible combinations of the two characterizations of the three characteristics.

The Flight Phase Categorization scheme is diagrammed in Figure 1.5-1. Two examples are to be traced through the Flight Phase Categorization decision tree in Fig. 1.5-1.

Example Flight Phases:

1. Terrain Following
 - Maneuvering - Rapid
 - Precise Flight Path or Space Position Control - Yes
 - Target Tracking - No

2. Loiter
 - Maneuvering - Gradual
 - Precise Flight Path or Space Position Control - No
 - Target Tracking - No

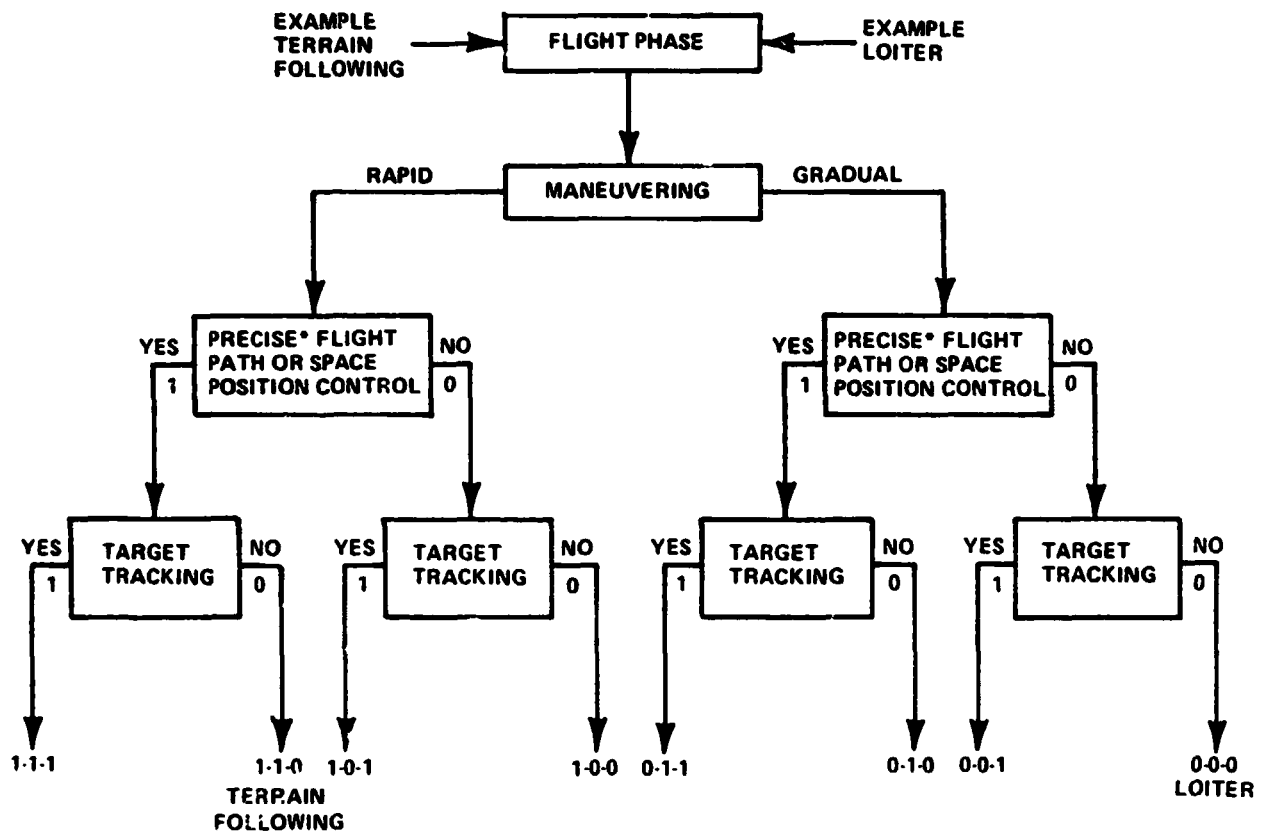

*QUANTITATIVE DEFINITIONS OF PRECISE FLIGHT PATH OR SPACE POSITION CONTROL MUST BE MADE BY THE PROCURING ACTIVITY FOR INDIVIDUAL FLIGHT PHASES.

e.g. 50 ft < TERRAIN CLEARANCE < 200 FT

Figure 1.5-1 FLIGHT PHASE CATEGORIZATION SCHEME

Quantitative definitions of precise flight path or space position control must be made by the procuring activity for individual Flight Phases. For example, mine countermeasures and cruise along an airway at altitude above a cloud layer are both Category 010 Flight Phases but differ substantially in the precision of velocity and flight path control required. These differences should be recognized in the statement of precision required and could lead to totally different complements of navigation/guidance sensors, information displays and augmentation systems for the two Flight Phases. In Paragraph 1.5 the term target tracking is employed as opposed to orientation control because it is intended that this characterization relates to the capability to aim weapons or designators at ground or airborne targets. In general, this capability is determined not only by the angular orientation dynamics but also by the flight path dynamics of the vehicle.

As can be seen from the tabulations in Paragraph 1.5, with two choices for each of the control task attributes, it is possible that eight separate parameter values may be required for each requirement. For this situation to be true, however, implies that the requirements for maneuvering, space positioning and tracking are all dependent which is not necessarily the case. For example, the difference between rapid and gradual maneuvering may be only in the force or moment control power required, independent of the static and dynamic stability. Requirements specifying control power, therefore, need only be directed at Flight Phases on the basis of required maneuvering capability. This can be done by using the designators IXX and OXX in the requirement statement, where the X notations means the requirement applies independent of the precision of flight path control or whether target tracking is involved. A given requirement can be designated to apply to any combination of Flight Phase Categories by simply listing the category designators or by grouping them under a new symbol such as Group A - 111, 110, 101, 011; Group B - 100, 010, 001, 000. In summary, the breakdown of categories for flight Phases is considered to be sufficiently broad to allow tailoring of flying qualities requirements to representative operational requirements but not so "fine-grained" that the derivation of appropriate requirements becomes an unmanageable task.

Application of Paragraphs 1.2 - 1.5

At this point in the discussion of the specification structure it is appropriate to apply the definitions in 1.2 - 1.5 to several specific Flight Phases in order to demonstrate that the structure has been conceived in a format which will be useful,

to both the procuring activity and the contractor, in defining the design problem. The following four Flight Phases are addressed in Tables 1.5-1 through 1.5-4.

1. High speed terrain following
2. Pick-up and precise placement of MILVAN on transporter.
3. Landing approach
4. Air-ground weapon delivery

Paragraphs 1.2 and 1.5 require identifying, characterizing and categorizing the Flight Phases. Included in this process is a requirement to define the meaning of precise flight path or space position control in the context of the Flight Phase. Paragraph 1.3 requires identifying the Flight Region in which the Flight Phase will be performed. Paragraph 1.4 requires specification of the Operational Capability Classification. Each of these steps are illustrated in Tables 1.5-1 through 1.5-4. Also included in the tables are definitions of the operating environment and commentary on the design implication of the assembled information.

The example in Table 1.5-1 is for high speed terrain avoidance. The performance standard specified and the requirement that the Flight Phase must be performed without external visual cues combine to require sensors, stored terrain features, computers, navigation equipment, displays, augmentation and/or automation of the flight control system.

The example in Table 1.5-2 is for pick-up and precise placement of a MILVAN on a transporter. The performance standard and the designation of Operational Capability Class III combine to require special sensors to determine location of the transporter and the MILVAN and to stabilize the rotorcraft. The performance standard and the environment may determine the need for gust rejection stabilization. Information and director displays may be required. The heavy lift helicopter was designed with a special control station and controller installation which permitted the load controlling crewman to keep the MILVAN and transporter in view during operations.

The example in Table 1.5-3 is for landing approach. The requirement is for a capability to make approaches to a landing area at a speed within the Forward Flight Region in bad weather. Operational Capability Class IV is required to within 1/4 mile visual range and 200 ft ceiling conditions. If the data in Figures 1.5-2 and 1.5-3 are valid, the choice of guidance equipment would be limited to either Airborne radar and radar altimeter or a microwave landing system with distance measuring equipment. A 3 cue flight director and stability augmentation may be required for Level 1 flying qualities.

The example in Table 1.5-4 is for air-ground weapon delivery. Designation of Operational Capability Class IVs together with the performance standard specified creates a demanding technological challenge which would require integration of a number of subsystems such as those listed in Table 1.5-4. The weapon delivery system developed under the Integrated Flight and Fire Control System program for the fixed wing F-15 airplane is conceptually described by the illustrations in Figure 1.5-4. Two concepts are outlined in Figure 1.5-4. In one concept, the pilot is a series link in the system and task performance is dependent on the pilot's ability to interface with the displays and the flight control system and to manage the weapon system. In the second concept, a limited authority automatic system is put in parallel with the piloted system and the role of the piloted is changed to be that of target acquisition and tracking within a larger window while the automatic system performs the precision tracking and automatic weapon release.

The example in Table 1.5-4 has been included in this discussion to emphasize that there are multiple design approaches to tasks as complex as air-ground weapon delivery. The flying qualities specification must not inhibit design solutions.

Table 1.5-1
EXAMPLE - HIGH SPEED TERRAIN AVOIDANCE

Flight Phase

- High Speed Terrain Avoidance

Flight Region

1.3.2 Forward Flight

Operational Capability Classification

CLASS IV Outside visual cues unavailable to the unaided eye

Flight Phase Category

I-1-0 Rapid maneuvering

Precise* flight path control

No target tracking

*Precise Maximum altitude 200 ft, Minimum altitude over peaks 50 ft. Speed 130 Kt

Environment Winds 50 kt, turbulence 6 ft/sec RMS

Terrain West Germany, Regensburg Gap or Fulda Gap

Implications

Terrain sensors required, stored map recall with feature correlation, Navigation System, Flight path calculation, command calculation, displays for pilot, automatic control of flight path, flight control augmentation.

Table 1.5-2
EXAMPLE - PICK-UP AND PRECISE PLACEMENT
OF MILVAN ON TRANSPORTER

Flight Phase

Pick-up and Precise Placement of MILVAN on transporter.

Flight Region

1.3.1 Hover and Low Speed

Operational Capability Class

CLASS III Low visibility

Flight Phase Category

0-1-0 Gradual maneuvers, Precise* position control, no target tracking.

*Precise - Place load within ± 1 inch of lock pins. Accomplish with less than 1 minute hover time.

Environment Load placement in wake of tree line with wind velocity of 70 ft/sec at
h = 140 ft. and turbulence of 6 ft/sec rms.

Implications

Position Sensors, Inertial Velocity Sensors
Accelerations, angular rates, attitudes, heading
Altitude. Cable angle, Cable Tension/length
Gust rejection stabilization
Augmentation and stabilization necessary

Table 1.5-3
EXAMPLE - LANDING APPROACH

Flight Phase

Landing Approach

Flight Region

1.3.2 Forward Flight

Operational Capability Classification

CLASS IV

Flight Phase Category

0-1-0 Gradual Maneuvers,
Accurate* Flight Path Control,
No Target Tracking

*Accurate Guidance to minimum breakout conditions of 200 ft altitude and
1/4 mile visual range

Environment Wind 50 ft/sec, cross wind 50 ft/sec, wind shear .14 ft/sec per ft.,
turbulence 6 ft/sec rms, Obstacles 50 ft. tower one quarter mile left of approach
path, Rain 50 mm/Hour.

Implications

Guidance Sensors Airborne radar, radar altimeter or MLS and DME

Flight director Probably 3 Cue for Level 1

Augmentation Rate augmented maybe attitude stabilized.

ORIGINAL PAGE IS
OF POOR QUALITY

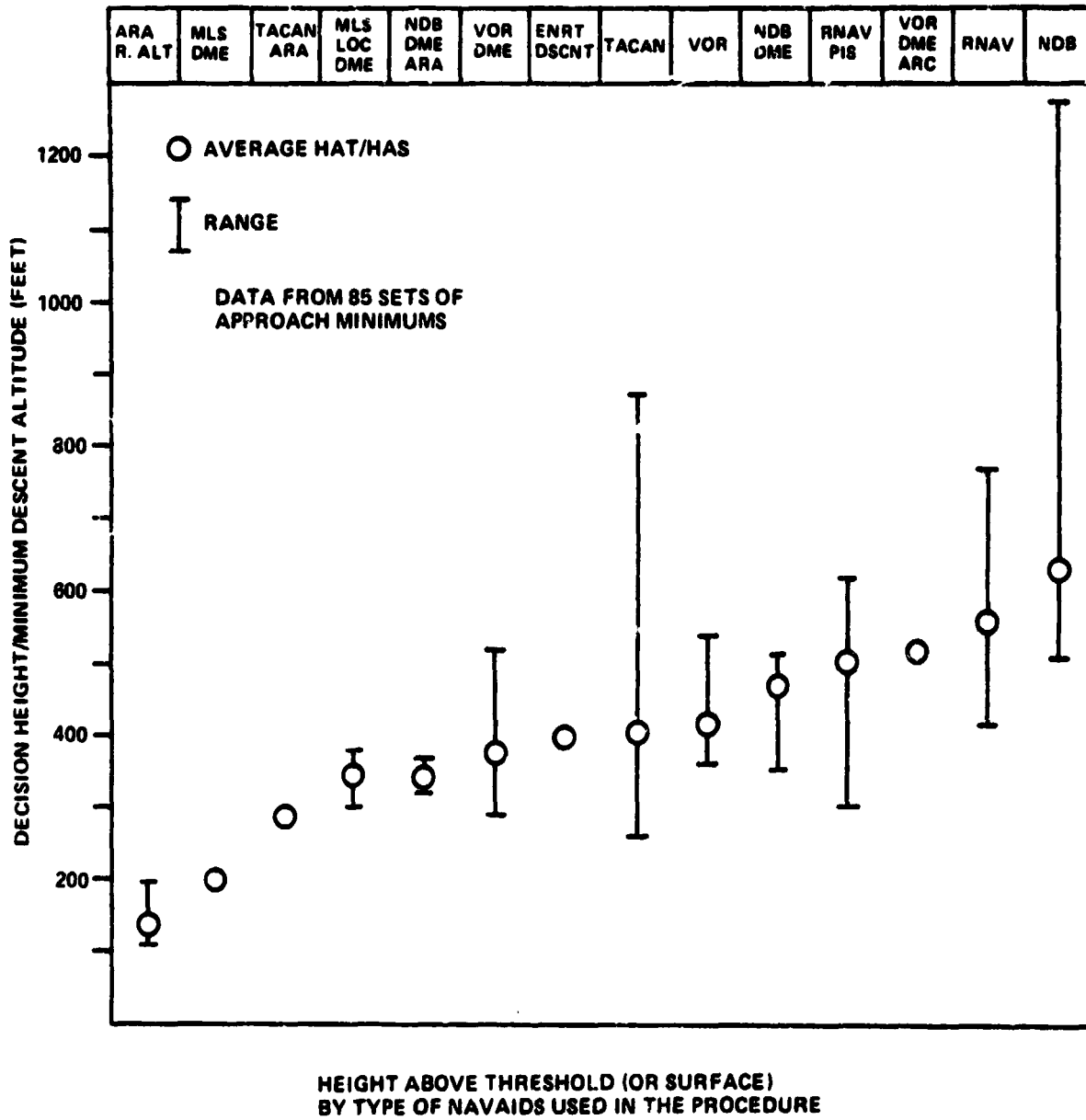

Figure 1.5-2 ALTITUDE MINIMUMS

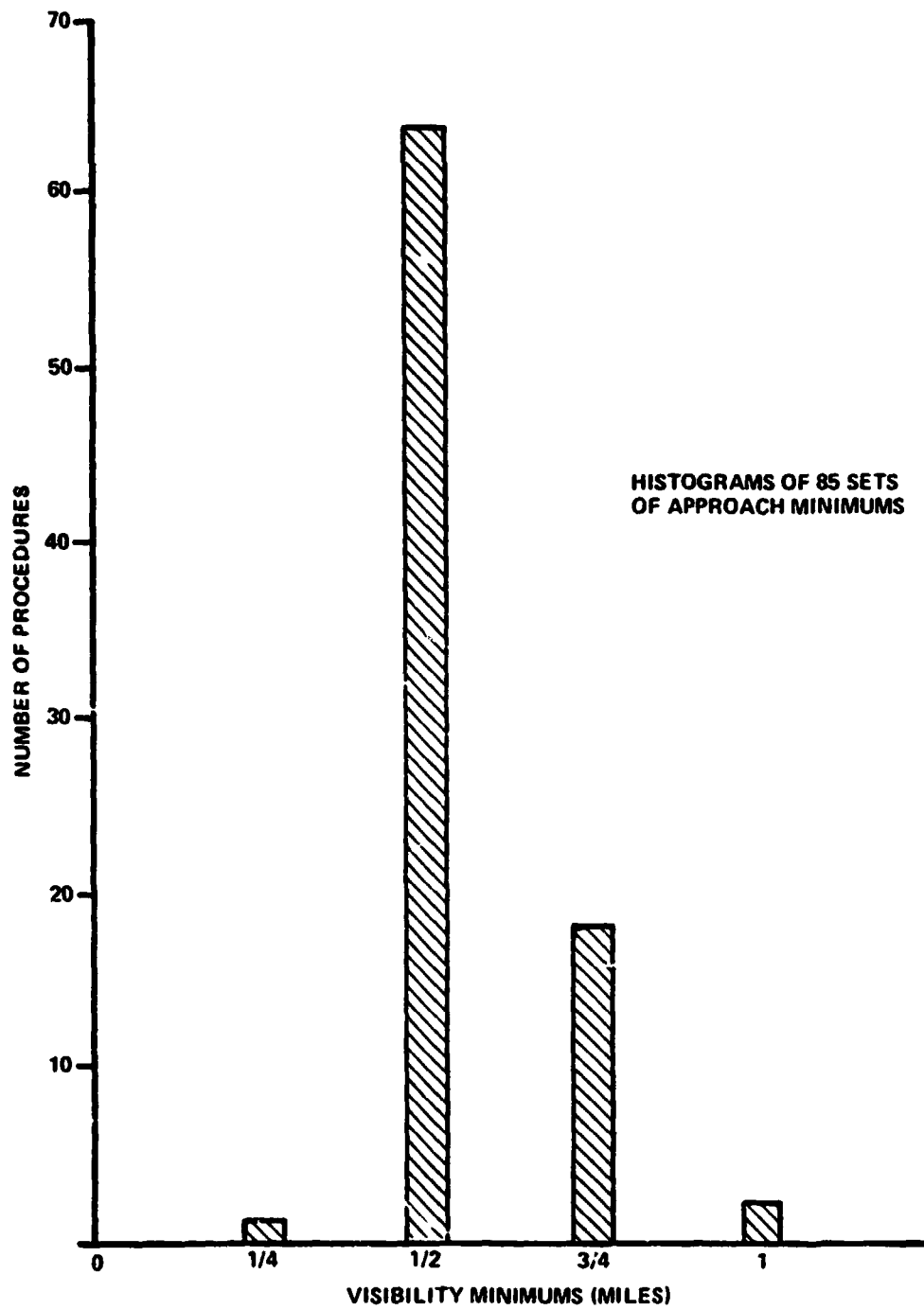

Figure 1.5-3 VISIBILITY MINIMUMS

C-3

Table 1.5-4
EXAMPLE - AIR-GROUND WEAPON DELIVERY

Flight Phase

Air-Ground Weapon Delivery

Flight Region

1.3.2 Forward Flight

Operational Capability Classification

Class IVs Outside visual cues not available to the unaided eye. Single crewman.

Flight Phase Category

1-1-1 Rapid maneuvering
 Precise* flight path and space position
 Target tracking
 *Precise Release Conditions:
 $V = 175 \text{ kt}$, $\gamma = -20^\circ$, Range 3000 ft
 Weapon delivery accuracy:
 $CEP \leq 10 \text{ ft}$

Environment Winds 50 kt, turbulence 6 ft/sec rms, visibility 1/2 mile, ceiling 200 ft

Implications

Fire control radar, sensor/tracker
 Head-up display, Flight/Fire Control Coupler
 Augmented/Automated Flight Control System
 Weapon System/Fire Control System

ORIGINAL PAGE IS
OF POOR QUALITY

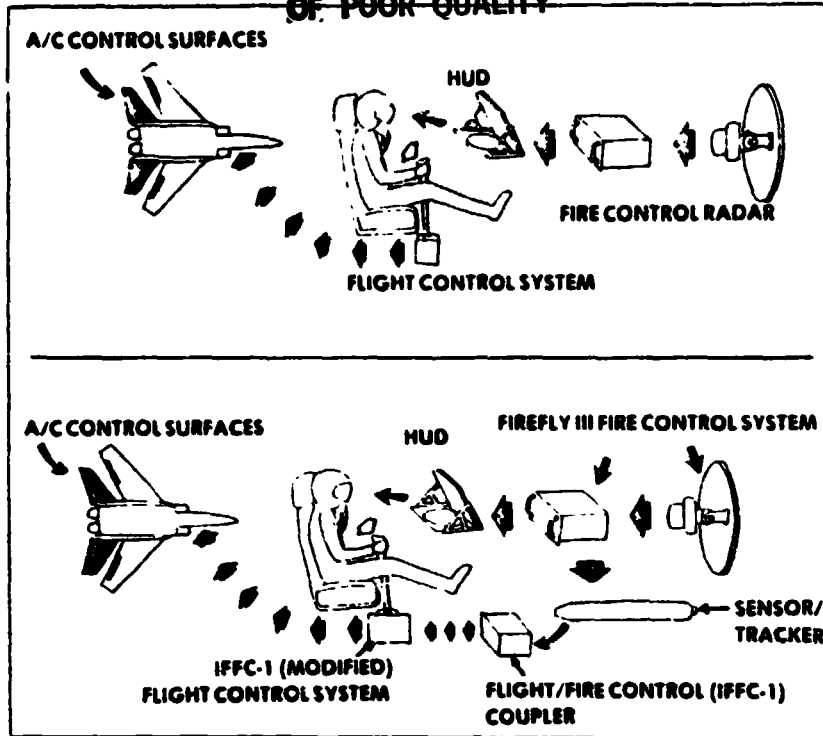

The flow of fire control information and flight control inputs in a conventional aircraft (diagram at top) is compared with the integrated fire control system and pilot inputs to the flight controls of an integrated systems aircraft (diagram at bottom). The integrated system keeps the pilot in the control loop, but flight control inputs are fine-tuned with information that is received directly from the fire control system and supplementary sensor/trackers.

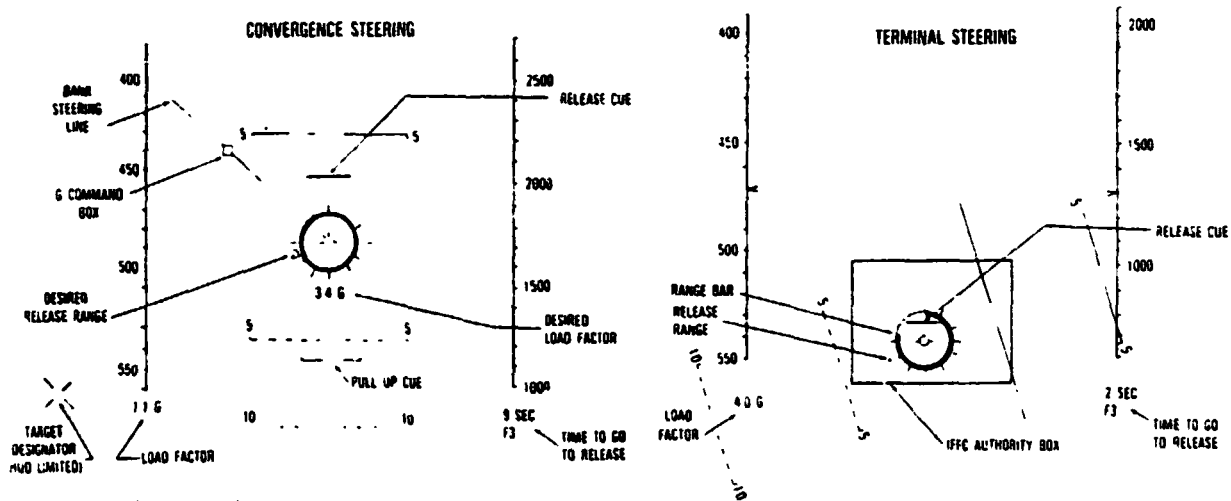

Head-up display symbology associated with the bombing mode of the F-15 integrated flight and fire control system (IFFC) is shown in these two drawings. In the convergence steering phase (left), the symbology provides the pilot with cues on the proper bank angle and load factor

that must be flown to bring the aircraft to the appropriate weapon release point. In the terminal steering phase (right), the pilot has only to fly the aircraft so that the circular aiming reticle is kept within the IFFC authority box until the weapon is released automatically.

Figure 1.5-4 EXAMPLE OF TWO DESIGN APPROACHES FOR AIR-GROUND WEAPON DELIVERY

1.6 LEVELS OF FLYING QUALITIES

Three Levels of flying qualities are defined as follows:

- Level 1: Flying qualities clearly satisfactory for the mission Flight Phase.
- Level 2: Flying qualities adequate to accomplish the mission Flight Phase, but some increase in pilot workload or degradation in mission effectiveness, or both, exists.
- Level 3: Flying qualities such that the rotorcraft can be controlled safely, in the mission Flight Phase, but pilot workload is excessive or mission effectiveness is inadequate, or both.

Where possible, the requirements of Section 3 have been stated in terms of three values of flying qualities parameters. Each value specified is a minimum condition to meet one of the defined levels of flying qualities. Ideally, values of the flying qualities parameters required for each level should be stated for each Flight Phase and Flight Environment for which the rotorcraft is to be designed. Available data does not permit this degree of specification. Some of the requirements, therefore, are qualitative or define a required operational capability. In these requirements, flying qualities parameters are not defined. It must be noted that while any flying qualities requirement or group of requirements may be necessary conditions for good flying qualities, meeting all the specified requirements may not be sufficient to ensure that the desired Level of flying qualities is achieved. The final decision as to whether or not the rotorcraft is approved will therefore depend on assessment of the overall characteristics.

DISCUSSION

The concept of specifying flying qualities in terms of Levels was introduced during the development of MIL-F-8785B (ASG). This concept is included in the rotorcraft flying qualities specification in a slightly modified form. The modification consists of "purifying" the Level definitions by eliminating all reference to application. The conditions for which Level 1 flying qualities are required and the conditions under which Level 2 and Level 3 flying qualities will be permitted are specified in 2.4.

The Level definitions are intended to relate to the Cooper-Harper pilot rating scale (Figure 1.6-1) when this rating scale is used in the context defined in NASA TN D-5153. This context requires that evaluations be based on performing the tasks associated with a Flight Phase in either the Operational Environment specified or the Most Severe Environment specified. Task performance standards must be defined for the Flight Phase and these performance standards must be applied by the pilot during evaluation of the rotocraft for the Flight Phase. Under these conditions, the following association between Levels and pilot ratings is intended.

Level 1	$PR \leq 3.5$
Level 2	$3.5 < PR \leq 6.5$
Level 3	$6.5 < PR \leq 9$

The flying qualities data base existing in the literature, however, does not always satisfy these conditions. In the process of formulating flying qualities requirements, it is necessary to examine the context in which data sets were generated and to exercise judgement in using the available data base to define the Level boundaries for the flying qualities parameters used in the specification.

In the last paragraph of 1.6 it is recognized that the set of flying qualities requirements contained in the specification are probably not sufficient to ensure the desired flying qualities will be attained in a given procurement. It is therefore necessary to base the final acceptance decision on assessment of the overall characteristics.

ORIGINAL PAGE IS
OF POOR QUALITY

HANDLING QUALITIES RATING SCALE

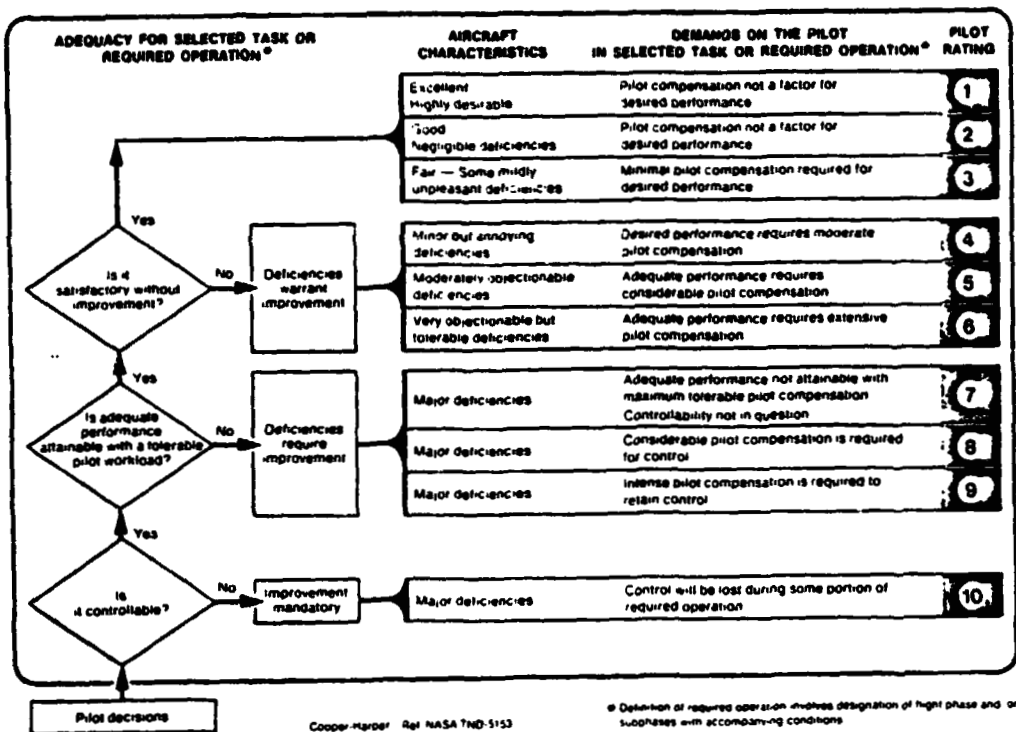

Figure 1.6-1 COOPER-HARPER RATING SCALE (FROM NASA TN D-5153)

2 DEFINITIONS AND APPLICABLE DOCUMENTS

2.1 DEFINITIONS OF THE ROTORCRAFT

2.1.1 Loadings

The contractor shall define the envelopes of center of gravity and corresponding weights that will exist for each Flight Phase. These envelopes shall include the most forward and aft center-of-gravity positions as defined in MIL-W-25140. In addition, the contractor shall determine the maximum center-of-gravity excursions attainable through failures in systems or components, such as fuel sequencing, hung stores, etc., for each Flight Phase to be considered in the Failure States of 2.1.4.2. Within these envelopes, plus a growth margin to be specified by the procuring activity, and for the excursions cited above, this specification shall apply.

2.1.2 Moments of Inertia and Products of Inertia

The contractor shall define the moments of inertia and products of inertia associated with all loadings of 2.1.1. The requirements of this specification shall apply for all moments of inertia and products of inertia so defined.

2.1.3 External Stores

The requirements of this specification shall apply for all combinations of external stores and all methods of attachment of external stores required by the operational missions. The Effects of external stores on the weight, moments of inertia, center-of-gravity position, and aerodynamic characteristics of the combined rotorcraft and external stores shall be considered for each mission Flight Phase. When the stores contain expendable loads, the requirements of this specification apply throughout the range of store loadings. The external stores and store combinations to be considered for flying qualities design will be specified by the procuring activity. In establishing external store combinations to be investigated, consideration shall be given to asymmetric as well as to symmetric combinations, and to variations in mass distribution within external stores.

DISCUSSION

The loading of a rotorcraft is determined by what is in (internal loading), and attached to (external loading) the rotorcraft. The parameters that define different characteristics of the loading are weight, center-of-gravity position, and moments and products of inertia. External stores affect all these parameters and also affect aerodynamic coefficients.

The requirements apply under all loading conditions associated with the operational missions. Since there is an infinite number of possible internal and external loadings, each requirement generally is only examined at the critical loading with respect to the requirement. Only permissible center-of-gravity positions need be considered for Rotorcraft Normal States. But fuel sequencing and transfer failures or malperformance that get the center of gravity outside the established limits are expressly to be considered as Rotorcraft Failure States. The worst possible cases that are not approved Special Failure States (2.1.5.4) must be examined.

Since the requirements apply over the full range of service loadings, effects of fuel slosh and shifting should be taken into account in design. Balance, controllability, and airframe and structural dynamic characteristics may be affected. For example, takeoff acceleration has been known to shift the c.g. embarrassingly far aft. Rotorcraft attitude may also have an effect. Other factors to consider are fuel sequencing, in-flight refueling if applicable, and all arrangements of variable, disposable and removable items required for each operational mission.

The procuring activity may elect to specify a growth margin in c.g. travel to allow for uncertainties in weight distribution, stability level and other design factors, and for possible future variations in operational loading and use.

In determining the range of store loadings to be specified in the contract, the procuring activity should consider such factors as store mixes, possible points of attachment, and asymmetries—initial, after each pass, and the result of failure to release. The contractor may find it necessary to propose limitations on store loading to avoid excessive design penalties.

The designer should attempt to assure that there are no restrictions on store loading, within the range of design stores. However, it is recognized that occasionally this goal will be impracticable on some designs. It may be impossible to avoid exceeding rotorcraft limits, or excessive design penalties may be incurred. Then, insofar as considerations such as standardized stores permit, it should be made physically impossible to violate necessary store loading restrictions. If this too should not be practicable, the contractor should submit both an analysis of the effects on flying qualities of violating the restrictions and an estimate of the likelihood that the restrictions will be exceeded.

2.1.4 Configurations

The requirements of this specification shall apply for all configurations required or encountered in the applicable Flight Phases of 1.2. A (crew-) selected configuration is defined by the positions and adjustments of the various selectors and controls available to the crew (except for the primary longitudinal, lateral, yaw, thrust magnitude, and trim controls), for example, flap setting, R.P.M. setting, thrust vector setting, stability-augmentation-system (SAS)-selector setting, etc. The selected configurations to be examined must consist of those required for performance and mission accomplishment. Additional configurations to be investigated may be defined by the procuring activity.

DISCUSSION

The settings of configuration controls (e.g. pylon tilt angle, tail plane angle, external stores, speed brakes, landing gear) are related uniquely to each rotorcraft design. The specification requires that the configurations to be examined shall be those required for performance and mission accomplishment. The position of roll, pitch, yaw controls, trim controls and the collective or thrust magnitude control are not included in the definition of configuration since the positions of these controls are usually either specified in the individual requirements or determined by the specified flight conditions.

Where a distinction is required, the requirements are stated for Flight Phases, rather than for rotorcraft configurations, since the flying qualities should be a function of the job to be done rather than of the configuration of the rotorcraft.

However, the designer must define the configuration or configurations which his rotorcraft will have during each Flight Phase.

2.1.5 State of the Rotorcraft

The State of the rotorcraft is defined by the selected configuration together with the functional status of each of the aircraft components or systems, thrust magnitude, weight, moments of inertia, center-of-gravity position, and external store complement. The trim setting and the positions of the longitudinal, lateral, and yaw controls are not included in the definition of Rotorcraft State since they are often specified in the requirements. The position of the thrust magnitude control shall not be considered an element of the Rotorcraft State when the thrust magnitude is specified in a requirement.

2.1.5.1 Rotorcraft Normal States

The contractor shall define and tabulate all pertinent items to describe the Rotorcraft Normal (no component or system failure) State(s) associated with each of the applicable Flight Phases. Certain items, such as weight, moments of inertia, center-of-gravity position, thrust magnitude and thrust angle control settings, may vary continuously over a range of values during a Flight Phase. The contractor shall replace this continuous variation by a limited number of values of the parameter in question which will be treated as specific States, and which include the most critical values and the extremes encountered during the Flight Phase in question.

2.1.5.2 Rotorcraft Failure States

The contractor shall define and tabulate all Rotorcraft Failure States, which consist of Rotorcraft Normal States modified by one or more malfunctions in rotorcraft components or systems; for example, a discrepancy between a selected configuration and an actual configuration. Those malfunctions that result in center-of-gravity positions outside the center-of-gravity envelope defined in 2.1.1 shall be included. Each mode of failure shall be considered. Failures occurring in any Flight Phase shall be considered in all subsequent Flight Phases.

2.1.5.3 Rotorcraft Specific Failure States

Requirements are included which limit the effects of specific failures. These requirements shall be met on the basis that the Specific Failure has occurred, regardless of its probability of occurrence. Consideration of a failure as a Specific Failure does not exempt that same failure from consideration on a probability basis according to 2.3.3

2.1.5.4 Rotorcraft Special Failure States

Certain components, systems, or combinations thereof may have extremely remote probability of failure during a given flight. These failure probabilities may, in turn, be very difficult to predict with any degree of accuracy. Special Failure States of this type need not be considered in complying with the requirements of Section 3 if justification for considering the Failure States as Special is submitted by the contractor and approved by the procuring activity.

DISCUSSION

Normal States

These paragraphs introduce the Rotorcraft State terminology for use in the requirements. The contractor is required to define the Rotorcraft Normal States for each applicable Flight Phase. The position or operating condition of any feature which can effect flying qualities should be tabulated. Initially, variable parameters should be presented in discrete steps small enough to allow accurate interpolation to find the most critical values or combinations for each requirement. Then those critical cases should be added. As discussed under 2.1.1 - 2.1.3, center-of-gravity positions that can be attained only when prohibited, failed, or malfunctioning fuel sequencing need not be considered for Rotorcraft Normal States.

Failure States

There is more to determining Failure States than just considering each component failure in turn. Two other types of effects must be considered. First, failure of one component in a certain mode may itself induce other failures in the

system, so failure propagation must be investigated. Second, one event may cause loss of more than one part of the system. Events of "unlikely" origin from recent flight experience are listed as illustrations:

- Failure of one bracket that held lines from both hydraulic systems led to loss of integrity of both systems.
- An extinguishable fire that burned through lines from all hydraulic systems, that were routed through the same compartment.
- Spilled coffee on the pilots' console that shorted out all electrical systems; lightning strikes might do this, too.
- A loose nut (too thick a washer was used, so the self-locking threads were not engaged) which shorted all three stability augmentation channels of a triply redundant system.
- Undetected impurities in a batch of potting compound used in packaging stability augmentation system components; all affected channels shorted out at the high temperatures of supersonic flight, after passing ground checkout.
- Complicated ground checkout equipment and lengthy procedures that were impractical to use very frequently on the flight line, resulting in long flight times between flight control system electronics checks.

The insidious nature of possible troubles emphasizes the need for caution in design application.

In discussing redundant systems, it is axiomatic that the whole system must be redundant. However, a recent design used multiple-redundant SAS, but required environmental control for the electronic components; the environmental control system was not redundant. Thus the complex multiple-redundant SAS could have been put out of action by any failure of the air conditioning equipment.

When considering the necessity of redundancy, attention should not be focused on the control system to the exclusion of all else. For example, it may be necessary to duplicate certain essential instrumentation. The SV-5 had an extremely narrow angle-of-attack corridor during re-entry, but had only one angle-of-attack sensing vane and display. In such a case, where the information is so essential, redundancy may be warranted.

Regardless of the degree of redundancy, there remains a finite probability that all redundant paths will fail. A point of diminishing returns will be reached, beyond which the gains of additional channels are not worth the associated penalties.

Specific Failure States

The format of the specification permits designation of Specific Failure States that must be considered regardless of the probability associated with the occurrence of such a failure. In a particular procurement, the procuring activity may choose to ensure the operating integrity of the rotorcraft by extending and tailoring the list of Specific Failure States that the contractor must consider in designing the rotorcraft.

Special Failure States

Several categories of Special Failure States can be distinguished. Certain items might be approved more or less categorically:

- Control-stick fracture
- Basic airframe or control-surface structural failure
- Dual mechanical failures in general

In most cases, a considerable amount of engineering judgment will influence the procuring activity's decision to allow or disallow a proposed Rotorcraft Special Failure State. Probabilities that are extremely remote are exceptionally difficult to predict accurately. Judgments will weigh consequences against feasibility of improvement or alternatives, and against projected ability to keep high standards throughout design, qualification, production, use and maintenance. Meeting other pertinent requirements: MIL-F-9490, MIL-A-8860, etc., should be considered, as should

experience with similar items. Generally, Special Failure States should be brought to the attention of those concerned with flight safety.

Note that the approval of Rotorcraft Special Failure States is at the discretion of the procuring activity. In conjunction with certain requirements that must be met regardless of component or equipment status, granting or refusing approval can be used as desired to require a level of stability for the basic airframe, to rule out fly-by-wire control systems, to demand consideration of vulnerability, or even to rule out a type of configuration. For example, a rotor pitch link failure will result in loss of control; clearly no requirements can then be met, and the configuration is excluded, unless the pitch link control failure is allowed as a special failure. The procuring activity should state the considerations to be imposed, as completely as possible at the outset; but it is evident that many decisions must be made subjectively and many will be influenced by the specific design.

2.2 DEFINITION OF FLIGHT ENVELOPES

2.2.1 Operational Flight Envelopes

The Operational Flight Envelopes define the boundaries in terms of speed, altitude, and load factor within which the rotorcraft must be capable of operating in order to accomplish the operational missions for which it is being procured. Additional envelopes in terms of parameters such as rate of descent, flight-path angle, stress in critical components, and side velocity may also be specified. Envelopes for each applicable Flight Phase shall be established with the guidance and approval of the procuring activity.

2.2.2 Service Flight Envelopes

For each Rotorcraft Normal State (but with thrust varying as required), the contractor shall establish, subject to the approval of the procuring activity, Service Flight Envelopes showing combinations of speed, altitude, and load factor derived from rotorcraft limits as distinguished from mission requirements. Additional envelopes in terms of parameters such as rate of descent, flight-path angle, and side velocity may also be specified. A certain set or range of Rotorcraft Normal States generally will be employed in the conduct of a Flight Phase. The Service Flight Envelope for these

States, taken together, shall at least cover the Operational Flight Envelope for the pertinent Flight Phase.

2.2.3 Operating Limitations

The Operating Limitations shall encompass all regions in which operation of the rotorcraft is allowable. These are the boundaries of flight conditions which the rotorcraft is capable of safely encountering. Transient load factors, power settings, rotor speed, and emergency thrust settings may be representative of such conditions.

GENERAL DISCUSSION

The definition and use of Flight Envelopes is an attempt to restrict application of the requirements to regions in which compliance is essential. Thus, it is hoped to avoid the performance, cost and complexity penalties that might be associated with overdesign to provide excellent flying qualities at all flight conditions. Just as important, the Flight Envelopes should ensure that flying qualities will be acceptable wherever the rotorcraft is operated. In general, the boundaries of these envelopes should not be set by ability to meet the flying qualities requirements. Other factors will normally determine the boundaries unless specific deviations are granted. The rationale for each type of Envelope is presented later in the discussion of each paragraph; but here it is in order to discuss procedures in constructing and using the Envelopes.

The procuring activity must set down the capability it wants for primary and alternate missions, including maneuverability over the speed-altitude range. These are the minimum requirements on the Operational Flight Envelopes. At this stage the Flight Phases will be known. In response to these and other requirements, a contractor will design the rotorcraft. For that design the contractor can relate the Flight Phases to Rotorcraft Normal States, then:

- Further define the Operational Flight Envelope for each Flight Phase, based on the associated Rotorcraft Normal States,
- Construct the larger Service Flight Envelope for the Rotorcraft Normal State associated with each Flight Phase, and

- Similarly define Operational Limitations or boundaries, beyond which operation is not allowed.

Each Envelope must include the flight conditions related to any pertinent performance guarantees.

Construction of Flight Envelopes for compound rotorcraft and V/STOL aircraft requires that consideration be given to configuration variables. At a particular altitude, a compound rotorcraft will be able to perform the maneuvering requirements corresponding to a given speed and altitude at a range of configurations (wing tilt angle, duct angle, nozzle setting, etc.). Thus an additional dimension which depends on the configuration is introduced into the Flight Envelope. For a rotorcraft with a single configuration variable λ , there would be a range of speeds over which the rotorcraft can be safely flown at the altitude being considered. The extremes of this range define the maximum and minimum service speeds for that configuration. Also at each λ there is a range of speeds over which the operational requirements of a particular Flight Phase can be satisfied at this altitude. The extremes of this range define the maximum and minimum operational speeds for that particular configuration; they are NOT necessarily $V_{O_{max}}$ and $V_{O_{min}}$ for the particular Flight Phase. Conversely, at a given speed there is a range of configurations at which the operational requirements of the Flight Phase can be satisfied.

The requirements of the specification apply at all points within the three-dimensional volume (speed, altitude and normal load factor, and possibly additional parameters such as rate of descent, flight path angle or side velocity) of the Flight Envelope, and also within the range of configurations. Hence, in effect, the requirements apply to a four-dimensional volume (or more if there is more than one independent configuration variable, e.g., wing tilt angle and flap angle would be two variables unless uniquely related). In picking the conditions within this four-dimensional space at which to determine compliance, consideration should be given to the critical flight conditions and how the rotorcraft will be flight tested.

Some Flight Phases will involve the same, or very similar, Rotorcraft Normal States; so one set of Flight Envelopes may represent several Flight Phases.

Each Flight Phase will involve a range of loadings. Generally it will be convenient to represent this variation by superimposing boundaries for discrete loadings, or possibly by bands denoting extremes. If different external store complements affect the Envelope boundaries significantly, it may be necessary to construct several sets of Envelopes for each Flight Phase, each set representing a family of stores. Hopefully a manageably small total number of Envelopes should result. It is apparent that the Flight Envelopes must and can be refined, as the design is further analyzed and defined, by agreement between the contractor and the procuring activity.

Flight tests will be conducted to evaluate the rotorcraft against requirements in known Flight Envelopes. Generally, flight tests will cover the Service Flight Envelope, with specific tests (stalls, dives, etc.) to the Operational limits. The same test procedures usually apply in both Service and Operational envelopes; only the numerical requirements and qualitative levels differ. If, for example, speed and altitude are within the Operational Flight Envelope but normal load factor is between the Operational and Service Flight Envelope boundaries, the requirements for the Service Flight Envelope apply. Ideally, the flight test program should also lead to definition of Flight Envelopes depicting Level 1 and Level 2 boundaries. These Level boundaries should aid the using commands in tactical employment, even long after the procurement contract has been closed out.

Separate Flight Envelopes are not normally allowed for Rotorcraft Failure States. It is rational to consider most failures throughout the Flight Envelopes associated with Rotorcraft Normal States. There may be exceptions (such as a thrust tilt angle failure that necessitates a partially converted landing) that are peculiar to a specific design. In such cases the procuring activity may have to accept some smaller Flight Envelopes for specific Failure States, making sure that these Envelopes are large enough for safe operation.

A sketch in Figure 2.2-1 illustrates the specification nomenclature for the Service and Operational Flight Envelopes.

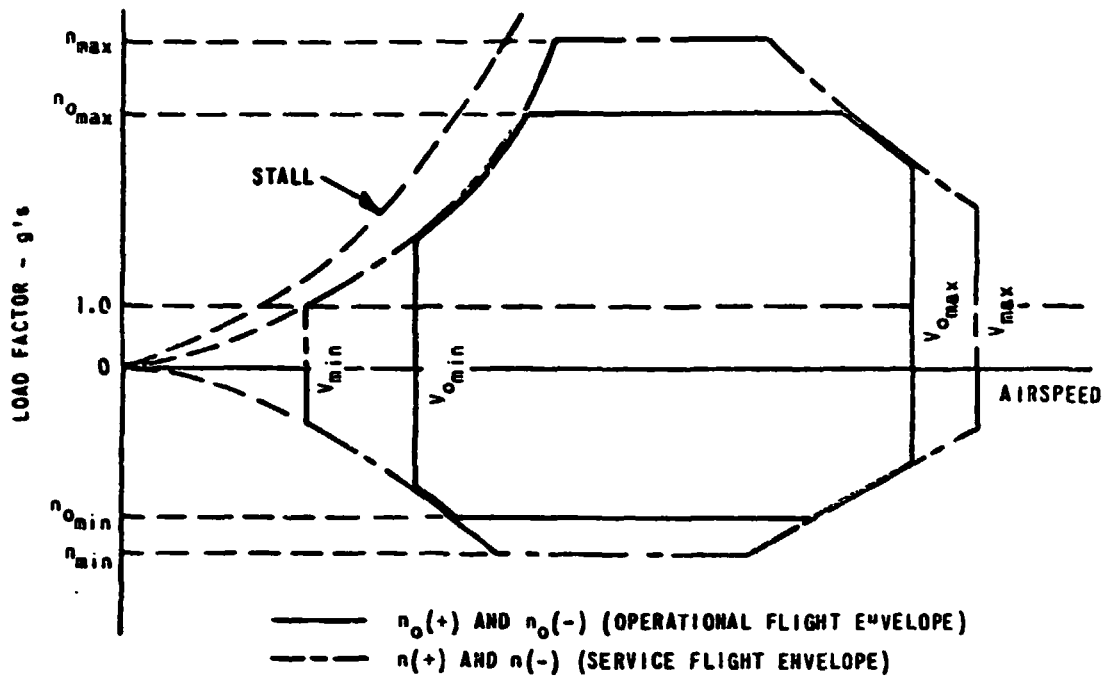

Figure 2.2-1 DEFINITION OF FLIGHT ENVELOPE TERMS

DISCUSSION OF OPERATIONAL FLIGHT ENVELOPES

Operational Flight Envelopes are regions in speed-altitude-load factor space (additional parameters such as rate of descent, flight path angle and side velocity may also be specified) where it is necessary for the rotorcraft, in the configurations and loading associated with a given Flight Phase, to have very good flying qualities, as opposed to regions where it is only necessary to ensure that the aircraft can be controlled without undue concentration. The Operational Flight Envelopes are intended to permit the design task to be more closely defined. As a result, the cost and complexity of the rotorcraft and possibly the cost and time required for flight testing should be appreciably, but logically, reduced. The required size of the Operational Flight Envelopes for a particular rotorcraft should, to the extent possible, be given in the detail specification for the rotorcraft, but some boundaries will only be delineated during design of the weapon system. In defining the speed-altitude-load factor combinations to be encompassed, the following factors should be considered:

- (a) The Operational Flight Envelope for a given Flight Phase should initially be considered to be as large a portion of the associated Service Flight Envelope as possible, to permit the greatest freedom of use of the rotorcraft by the using command.
- (b) If design trade-offs indicate that significant penalties (in terms of performance, cost, system complexity, or reliability) are required to provide Level 1 flying qualities in the large Envelope of (a) above, consideration should be given to restricting the Operational Flight Envelope toward the minimum consistent with the requirements of the Flight Phase of the operational mission under consideration.

Information on the intended use of the rotorcraft (required operational capability) should facilitate stating precise definitions of the various limits. Figure 2.2-2 illustrates possible Operational Flight Envelopes for a Flight Phase in the Hover and Low Speed Flight Region and for a Flight Phase in the Forward Flight Region. Side velocities resulting from the capability of translating at 35 knots in any direction are indicated on the V - n diagram.

For rotorcraft requiring a particular descent capability, additional envelopes of V - γ or V - h should be presented. Such envelopes may in any event be requested by the procuring activity. The procuring activity should also ensure that the Operational Flight Envelopes encompass the flight conditions at which all appropriate performance guarantees will be demonstrated.

DISCUSSION OF SERVICE FLIGHT ENVELOPE

The Service Flight Envelope encompasses the Operational Flight Envelopes for the same Flight Phase and Rotorcraft Normal State. Its larger volume denotes the extent of flight conditions that can be encountered without fear of exceeding rotorcraft limitations (safe margins should be determined by simulation and flight test). At least Level 2 handling qualities are required for normal operation. This allows a pilot to accomplish the mission Flight Phase associated with the Rotorcraft Normal State although mission effectiveness or pilot workload, or both, may suffer somewhat.

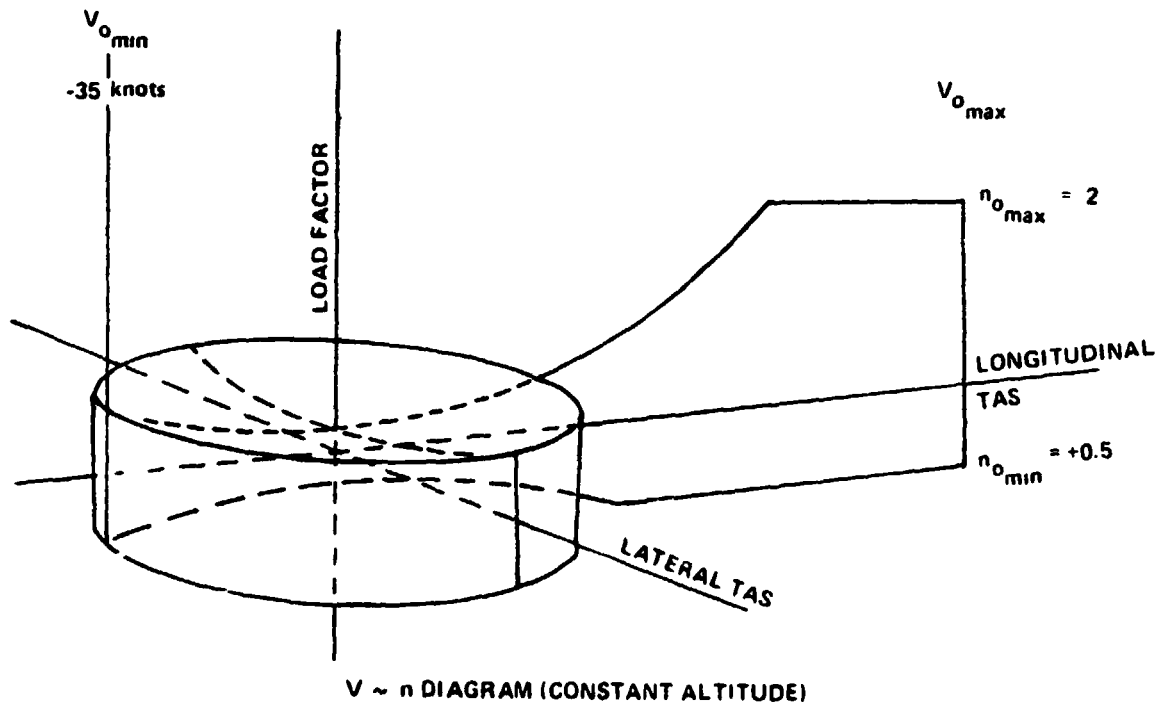
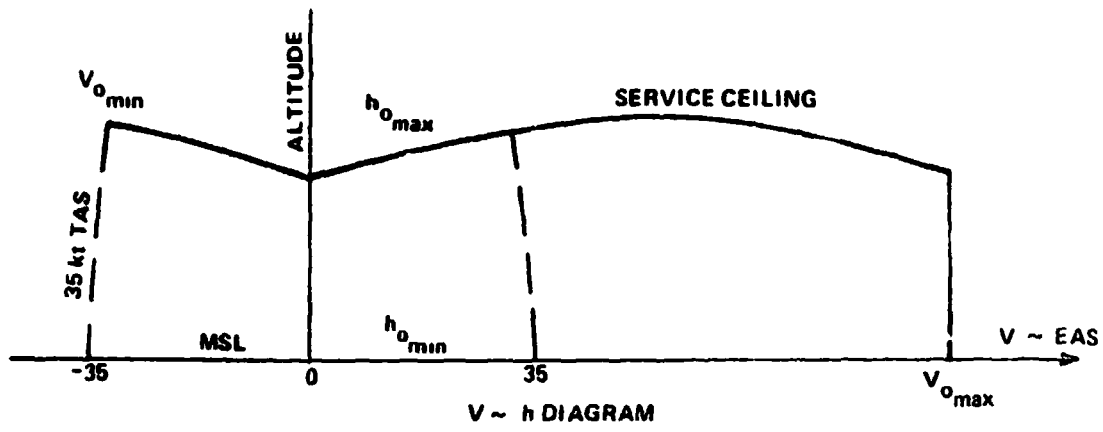

Figure 2.2-2 TYPICAL OPERATIONAL FLIGHT ENVELOPES FOR A FLIGHT PHASE IN THE HOVER AND LOW SPEED FLIGHT REGION AND A FLIGHT PHASE IN THE FORWARD FLIGHT REGION

This Envelope is also intended to insure that any deterioration of handling qualities will be gradual as flight progresses beyond the limits of the Operational Flight Envelope. This serves two purposes. It provides some degree of mission effectiveness for possible unforeseen alternate uses of the rotorcraft, and it also allows for possible inadvertent flight outside the Operational Flight Envelope.

DISCUSSION OF OPERATING LIMITATIONS

For each Rotorcraft State, there will be operating limitations which must be observed for safety of flight. Examples are speed, load factor, sideslip angle, rotor rpm, collective pitch, structural loads, fatigue loads etc. These Operating Limitations must be defined through analysis, simulation and flight test as the rotorcraft design, development and test program progresses. The Operating Limitations defined by this process should be included in the Pilot's Handbook.

2.3 DEFINITIONS OF THE ENVIRONMENT

The environments in which the mission Flight Phases must be accomplished are defined in paragraphs 2.3.1 and 2.3.2. Detail features and mathematical models of the environment are defined in the paragraphs of 3.9.

2.3.1 Operational Environments

Operational Environments define the sets of environmental conditions (in terms of atmospheric conditions, ambient light and terrain characteristics), in which the rotorcraft must be capable of operating in order to accomplish the operational missions for which it is being procured. Operational Environments for each of the following Flight Regions:

- Hover and Low Speed
- Forward Flight
- Takeoff and Landing
- Ground Handling

shall be established by the procuring activity. In the absence of specific guidance, the contractor shall use the representative conditions of paragraph 3.9 for the applicable Flight Regions.

2.3.2 Most Severe Environments

The Most Severe Environmental conditions define the sets of environmental conditions (in terms of atmospheric conditions, ambient light and terrain characteristics) in which the rotorcraft must be capable of safe operation. The Most Severe Environmental Conditions for each of the following Flight Regions:

Hover and Low Speed

Forward Flight

Takeoff and Landing

Ground Handling

shall be established by the procuring activity. In the absence of specific guidance, the contractor shall use the severe environment conditions of paragraph 3.9 for the applicable Flight Regions.

DISCUSSION

These paragraphs require the procuring activity to define sets of environmental conditions for the contractor to use in the design process. The first set defines the environmental conditions in which it must be possible to perform the operational mission Flight Phases with desired or adequate performance. The second set of environmental conditions defines the most severe conditions that the contractor is required to consider in the design process and for which the primary requirement is flight safety in the context of the Flight Phase.

The environment in which a Flight Phase must be performed has a major influence on the stability and control characteristics and information displays that will be required to provide good flying qualities and the capability to perform the Flight Phase. The most benign environment is probably clear, calm, cool air over level but well-textured terrain. A likely degradation in this environment is wind, windshear and turbulence. These air motions cause force and moment disturbances to be applied to the rotorcraft which complicate the pilot's job of stabilizing and guiding the flight of the rotorcraft relative to the ground. Wind also complicates the control problem because the lift performance at low speed is dependent on airspeed, which is difficult to determine, and not ground speed which is more easily observable.

Light conditions are a major factor of the environment that effects the ability to operate rotorcraft. Conditions can vary from bright sunlight to total darkness with varying degrees of light intensity caused by sun and moon locations together with cloud conditions. The availability of artificial light sources such as city lights, fires or light patterns designed to aid flight operations are also a significant factor of the environment. Independent of light conditions, the visibility can be restricted or obscured by haze, rain, fog, snow and dust.

The Flight Phase environment has still more dimensions, for example, the performance capability is influenced by density altitude, humidity and the accumulation of ice. For takeoff, landing and NOE or terrain following operations, the characteristics of the landing area and the terrain have an effect on the characteristics that the rotorcraft must have for successful operation. Landing surfaces may be varied in nature and degree of levelness and firmness. In Navy operations the landing surface may be in constant motion with the amplitude and character of the motion dependent on ship type and sea state. The difficulty involved in performing NOE and terrain following or avoidance operations is related to the terrain contours and presence of obstacles such as trees, towers, cables, structures and enemy defenses. The agility required is related to these features and the speed at which the rotorcraft is operated. Wind, windshear and turbulence are often correlated with terrain features, also, the wind-over-the-deck and the wake turbulence from ship structures can result in severe disturbance environments, for rotorcraft operations from small ships.

The wording of 2.3 is such that the procuring activity is charged with responsibility for defining the environmental conditions in which the rotorcraft is to be design to operate. These conditions are to be defined for each Flight Phase. During the process of defining the environmental conditions, the procuring activity should consider the mission requirements for the particular procurement. Section 3.9 of the specification contains a catalog of models, parameter magnitudes and references which can be used by the procuring activity as background information when developing the Operational and Most Severe Environment definitions for a specific procurement. In the event the procuring activity does not provide specific guidance, the contractor is directed to use the environment definitions of 3.9 to design and evaluate the rotorcraft.

2.4 DEFINITION OF CONDITIONS FOR WHICH DEGRADED FLYING QUALITIES ARE PERMITTED

2.4.1 Applications of Levels

Levels of flying qualities as indicated in 1.6 are employed in realization of the possibility that the rotorcraft may be required to operate under abnormal conditions. Such abnormalities that may occur (as a result of either flight outside the Operational Flight Envelope, the failure of rotorcraft components, or flight in a severe environment) are permitted to comply with the degraded Level of flying qualities as specified in 2.4.2 through 2.4.3.

DISCUSSION

This paragraph identifies the conditions under which degradation of flying qualities will be permitted. The conditions involve

Flight Envelopes - Operational or Service
Rotorcraft States - Normal or Failure
Environments - Operational or Most Severe

The concept of permitting degraded flying qualities for flight outside the Operational Flight Envelope and for Failure States was incorporated into MIL-F-8785B/ASG) and MIL-F-83300. This concept is intuitively and technically consistent in the sense that flight outside the Operational Flight Envelope may result in changes in stability derivatives or dynamic pressure that result in flying qualities parameters that are no longer Level 1. Also, failures may result in changes of the quantitative flying qualities parameters such that they are no longer Level 1. In these situations, changes in the rotorcraft stability and control parameters result in degraded flying qualities parameters which correlate with degraded pilot rating and degraded flying qualities Levels.

Flight in a severe environment, however, presents a significantly different situation because encounter of the more severe environment may have no effect on the rotorcraft stability and control parameters and yet the pilot rating may be degraded because the workload is increased or the pilot's ability to perform the tasks required by the Flight Phase is decreased. This situation is illustrated conceptually in Figure 2.4-1 which shows pilot rating as a function of turbulence rms intensity for two

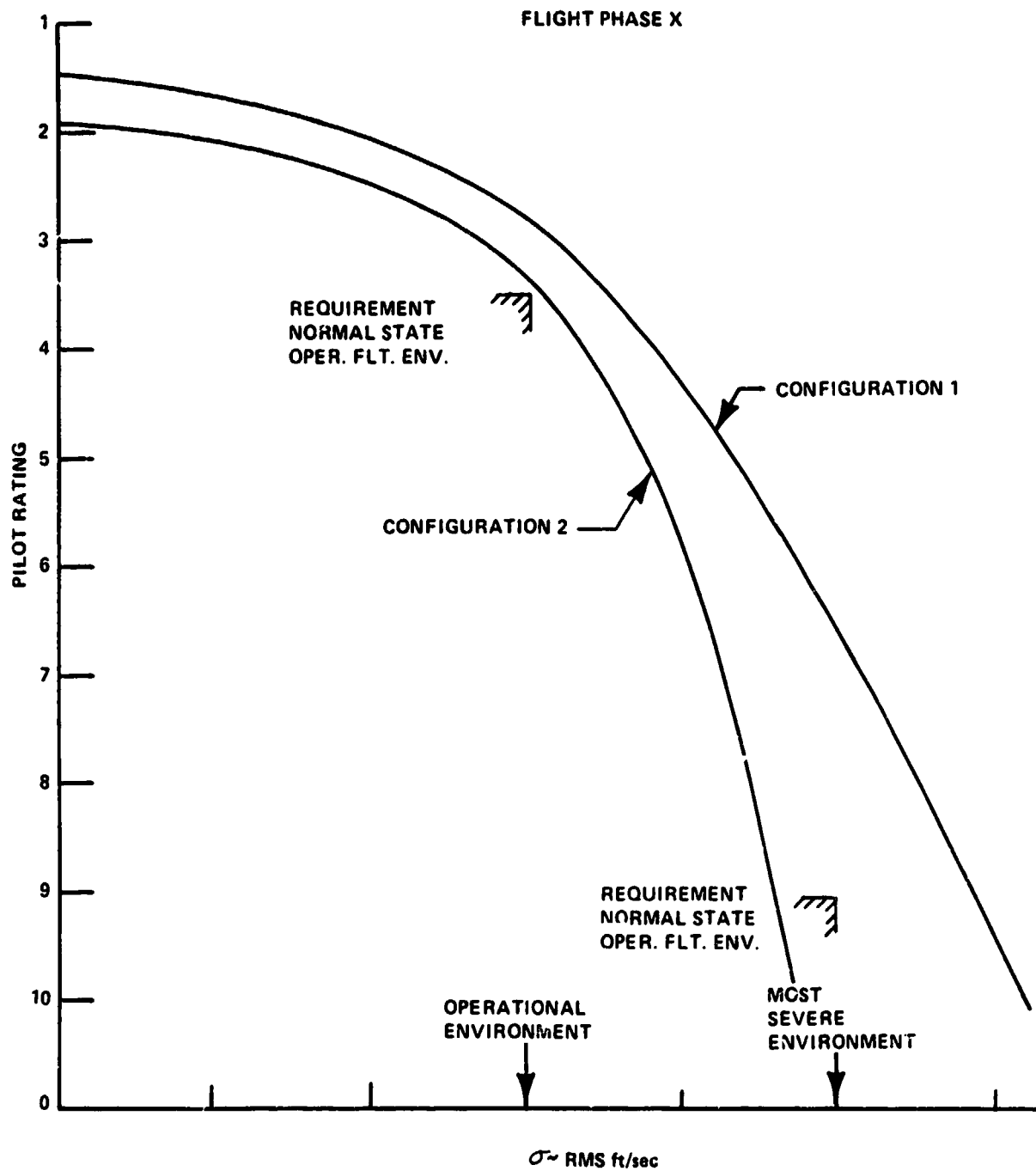

Figure 2.4-1 HYPOTHETICAL VARIATION OF PILOT RATING WITH TURBULENCE INTENSITY

hypothetical configurations evaluated for a given Flight Phase. This example is constructed such that both configurations receive $PR < 3.5$ for the turbulence intensity defined as the Operational Environment. Configuration 2, however is more responsive to turbulence than Configuration 1 and for the turbulence intensity designated as the Most Severe Environment, Configuration 2 has a $PR > 9$ and Configuration 1 has a $PR < 9$.

If we had a thorough data base relating pilot rating to turbulence intensity for all Flight Phases and a range of rotorcraft characteristics, it would be possible to formulate quantitative flying qualities requirements which would limit the responses of the rotorcraft to the more severe turbulence environments. Unfortunately, such a data base does not exist and therefore it is not possible to write substantiated requirements in this area. The desired goals, however, are known and can be stated in terms of pilot ratings or Levels that should be achieved in piloted simulations or through piloted evaluations of the rotorcraft in flight.

The turbulence intensity designated by the procuring activity as the Operational Environment can be a major factor in the design of the rotorcraft and flight control system. This effect is indicated conceptually in Figure 2.4-2 where hypothetical relationships between required augmentation and turbulence rms intensity are suggested for two rotorcraft designs. In Figure 2.4-2 it is hypothesized that as the designated Operational Environment becomes more severe it will be necessary to progressively add rate damping, attitude stabilization, and force alleviation in order to maintain Level 1 flying qualities. This progression occurs at lower turbulence intensities for Configuration 2 than for Configuration 1 because Configuration 2 was assumed to have higher sensitivity to one or more components of the turbulence environment. The specification is deficient in quantitative requirements which would provide guidance to the designer or permit quantitative evaluation of proposed designs to ensure that Level 1 flying qualities are achieved in the designated Operational Environment.

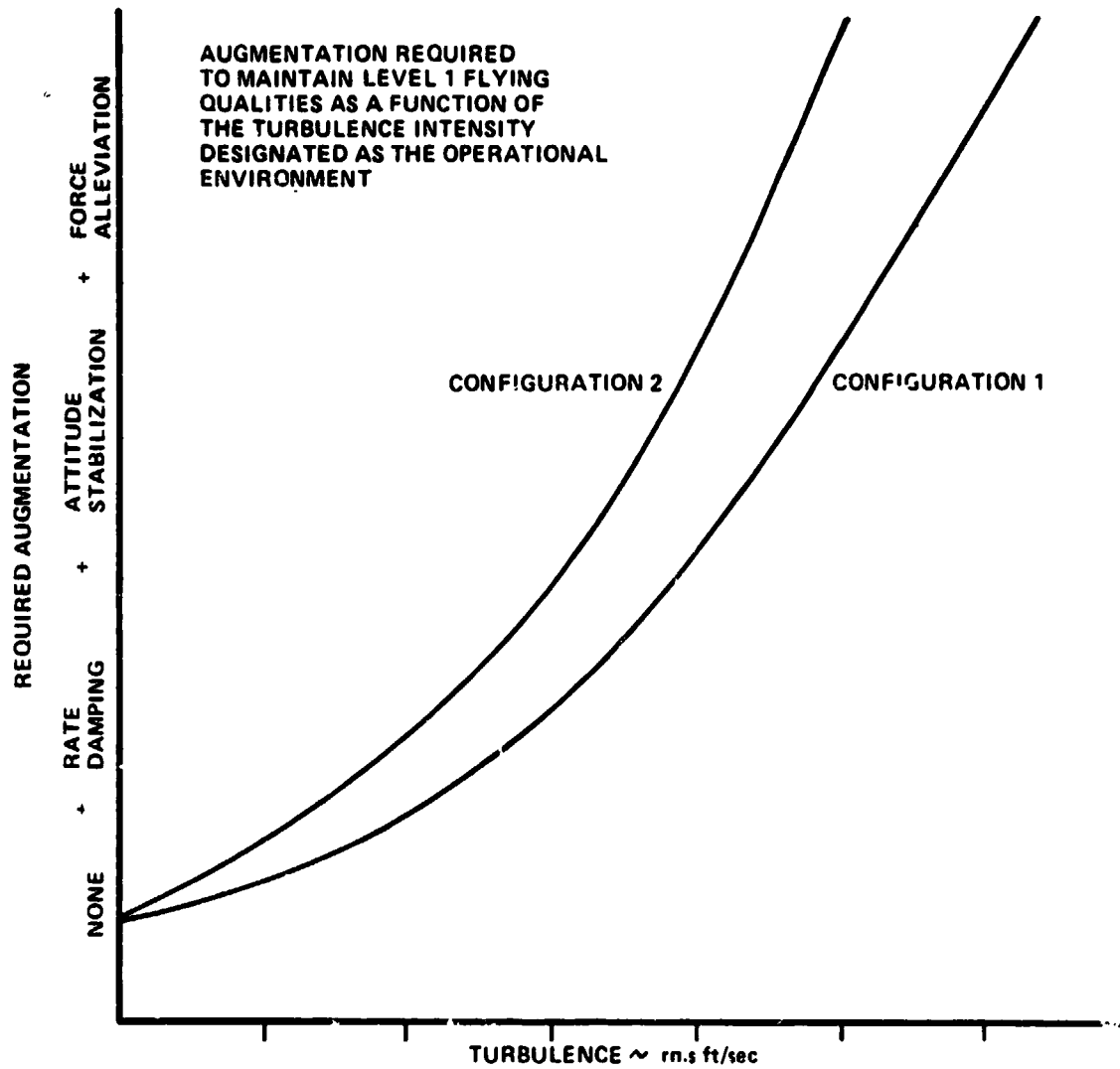

Figure 2.4-2 AUGMENTATION REQUIRED FOR LEVEL 1 AS A FUNCTION OF TURBULENCE INTENSITY

2.4.2 Requirements for Rotorcraft Normal States

The minimum required flying qualities for Rotorcraft Normal States (2.1.5.1) are as shown in Table I.

Table I
LEVELS FOR ROTORCRAFT NORMAL STATES

	Within Operational Flight Envelope	Within Service Flight Envelope
Operational Environment	Level 1	Level 2
Most Severe Environment	Landing Flight Phase Level 2 All Other Flight Phases Level 3	Capability Not Required

DISCUSSION

Table I defines the minimum required flying qualities for Rotorcraft Normal States. The table includes consideration of Flight Envelope, environment and Flight Phase. For Flight in the Operational Environment, Level 1 flying qualities are required in the Operational Envelope and Level 2 flying qualities are required in the Service Flight Envelope. Level 2 flying qualities are required for the Landing Flight Phase for flight in the Most Severe Environment applicable to that Flight Phase. Level 3 flying qualities are required for all other Flight Phases in the Most Severe Environment applicable to each Flight Phase. Because there is not an adequate data base to define quantitative flying qualities parameters for flight in severe environments, the minimum Levels designated in Table I for flight in the Most Severe Environment refer to the basic definitions of 1.6 and not to the Level 2 or Level 3 magnitudes of parameters in the quantitative requirements. As was discussed under 2.4.1 and illustrated in Figure 2.4-2, "increased" values of quantitative parameters such as damping ratio or natural frequency may be required to maintain a Level of acceptability when the severity of the environment is "increased". It is possible, therefore, that providing Level 2 flying qualities for Landing in the Most Severe Environment could require "higher" magnitudes

of quantitative parameters than would be required to provide Level 1 for Landing in the Operational Environment. A hypothetical example has been constructed in Figure 2.4-3 to illustrate this point. In the example, a "higher" parameter value would be required to provide Level 2 in the Most Severe Environment than would be required to provide Level 1 in the specified Operational Environment. It should be noted that pilot ratings and Levels are uniquely tied together by definition, the stability and control parameter values that provide a given Level of flying qualities are Flight Phase and environment dependent. No requirement is specified for flight in the Most Severe Environment while outside the Operational Flight Envelope.

2.4.3 Requirements for Rotorcraft Failure States

When Rotorcraft Failure States exist, a degradation in flying qualities is permitted only if the probability of encountering a lower Level than specified in 2.4.2 is sufficiently small. At intervals during the design process, the designer shall determine, based on the most accurate available data, the probability of occurrence of each Rotorcraft Failure State per flight and the effect of that Failure State on the flying qualities within the Operational and Service Flight Envelopes. These determinations shall be made under the following assumptions: (a) all rotorcraft components and systems are assumed to be operating for a time period, per flight, equal to the longest operational mission time to be considered by the designer in designing the rotorcraft, and (b) each specific failure is assumed to be present at whichever point in the Flight Envelope being considered is most critical (in the flying qualities sense). From these Failure State probabilities and effects, the designer shall determine the overall probability, per flight, that one or more flying qualities are degraded to Level 2 because of one or more failures. The designer shall also determine the probability that one or more flying qualities are degraded to Level 3. These probabilities shall be less than the values shown in Table II.

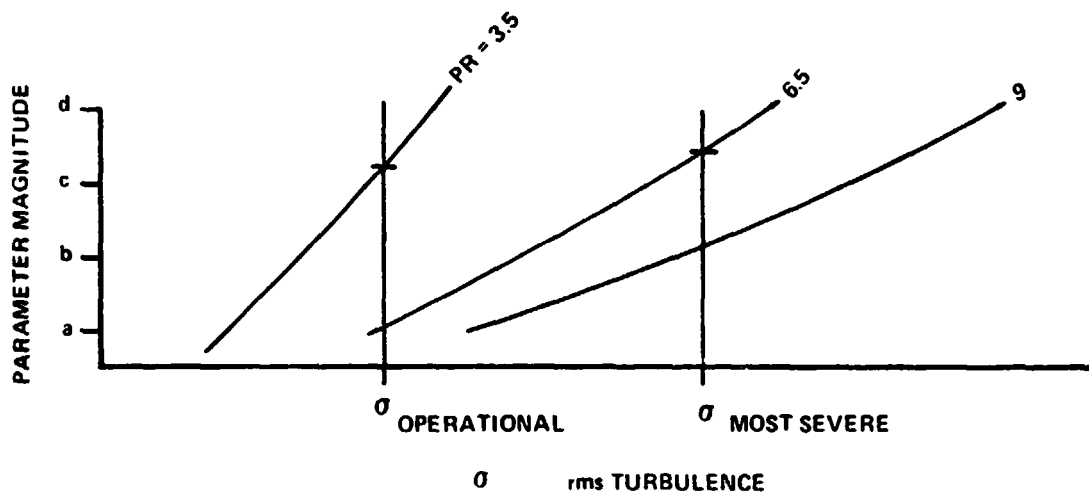
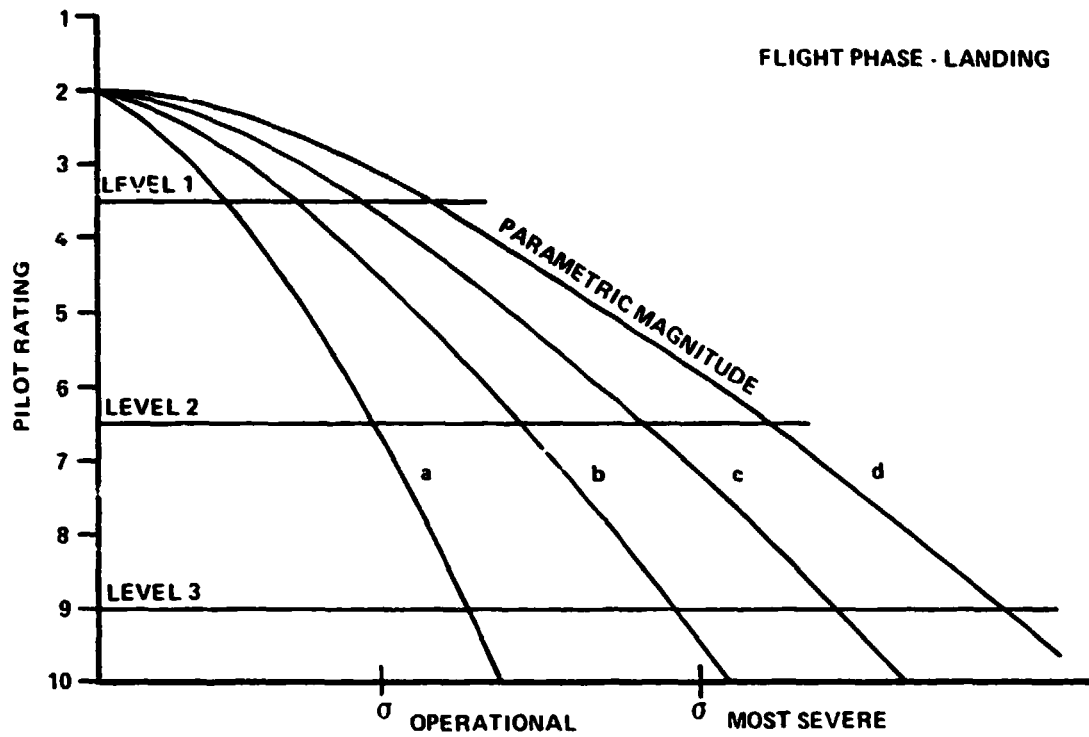

Figure 2.4.3 HYPOTHETICAL EXAMPLE

FLIGHT PHASE - LANDING
NORMAL STATE
OPERATIONAL FLIGHT ENVELOPE

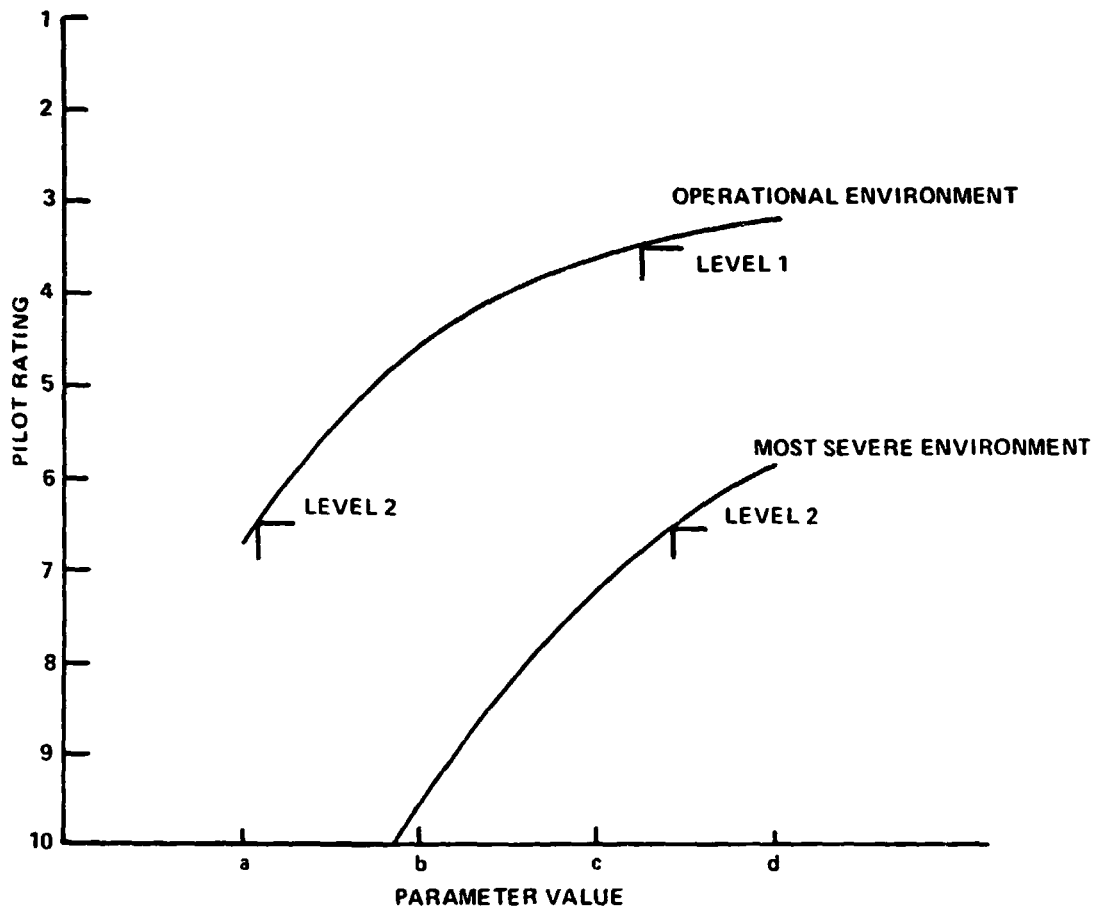

Figure 2.4-3 HYPOTHETICAL EXAMPLE (CONT.)

Table II
LEVELS FOR ROTORCRAFT FAILURE STATES

Probability of Encountering	Within Operational Flight Envelope	Within Service Flight Envelope
Level 2 after failure	10^{-2} per flight	
Level 3 after failure	10^{-4} per flight	10^{-2} per flight

In no case shall a Failure State (except an approved Special Failure State) degrade any flying quality outside the Level 3 limit.

DISCUSSION

The trend in rotorcraft flight control is toward application of sensors, computers, powered controls and electronic or optical signal transmission methods. This trend leads to increased control system complexity, and the necessity to face the problem of equipment failures in a realistic manner. The Level concept is directed at the achievement of adequate flying qualities without imposing undue requirements that could lead to unwarranted system complexity or decreased flight safety. Without actually requiring a good basic airframe, the general specification provides:

- High probability of good flying qualities where the rotorcraft is expected to be used.
- Acceptable flying qualities in reasonably likely, yet infrequently expected, conditions.
- A floor to assure, to the greatest extent possible, at least a flyable rotorcraft no matter what failures occur.
- A process to assure that all the ramifications of reliance on powered controls, stability augmentation, etc., receive proper attention.

In short, a systems approach to the requirement specification is used. The following paragraphs discuss this concept in some detail.

The Level approach is straightforward in concept. The requirements specified for normal operation (no system failures) provide desirable flying qualities. Equipment failures, however, either in the flight control system or other subsystems, can cause a degradation in flying qualities. The emphasis in the specification is on the effects of failures, rather than the failures themselves. Limited degradation of flying qualities (e.g., Level 1 to Level 2) is acceptable if the combined probability of such degradation is small. If the probability is high, then no degradation beyond the Level required for Normal States is acceptable after the failure occurs. Another way of stating this is that in the Operational Envelope the probability of encountering Level 2 any time at all on a given flight must not exceed 10^{-2} , and the probability of encountering Level 3 on any portion of the flight must not exceed 10^{-4} . Somewhat reduced requirements are imposed for flight within the Service Flight Envelope, for both Normal and Failure States. Outside the Service Flight Envelope, most of the requirements of the Specification do not apply.

Numerical Probabilities

The numerical values can, of course, be changed by the procuring agency to reflect specific requirements for a given weapon system. The procuring activity engineer should, as a matter of course, confer with both the using command representative and the reliability engineers to assure that the probabilities associated with the Levels are consistent with the design goals. The values given in Table II were initially proposed in MIL-F-8785B (ASG). Limited substantiation was developed in AFFDL-TR-69-72.

Implementation

Implementation of the Level concept involves both reliability analyses (to predict failure probabilities) and failure effect analyses (to insure compliance with requirements). Both types of analyses are in direct accord with, and in the spirit of, MIL-STD-756A (reliability prediction) and MIL-S-38130A (safety engineering). These related specifications are, in turn, mandatory for use by all Departments and Agencies of the Department of Defense. Implementation of the flying qualities specification is, for the most part, a union of the work required by these related specifications with normal stability and control analysis.

Failure States influence the rotorcraft configurations, and even the mission Flight Phases, to be considered. All failures must be examined which could have occurred previously, as well as all failures which might occur during the Flight Phase being analyzed. For example, failure of tilting rotors to tilt up during descent would require consideration of a rotors-down landing that otherwise would never be encountered. There are failures that would always result in an aborted mission, even in a war emergency. The pertinent Flight phases after such failures would be those required to complete the aborted (rather than the planned) mission. For example, failure of the rotors to tilt down after takeoff might mean a landing with the rotors at the takeoff setting, with certain unexpended external stores; but cruise would be impossible. If the mission might be either continued or aborted, both contingencies need to be examined.

The following general discussion is taken from MIL-F-83300 and MIL-F-8785B (ASG). Although the terminology is for airplanes, the concept is valid for rotorcraft. Additional discussion of failure analysis and implementation of the Levels concept is contained in AFFDL-TR-72-41.

A typical approach (but not the only one) for the system contractor is outlined below:

Initial Design: The basic airframe is designed for a Level 1 "target" in respect to most flying qualities in the Operational Flight Envelope. It may quickly become apparent that some design penalties would be inordinate (perhaps to provide sufficient aerodynamic damping of the short-period and Dutch-roll modes at high altitude); in those cases the basic-airframe "target" would be shifted to Level 2. In other cases it may be relatively painless to extend some Level 1 flying qualities over the wider range of the Service Flight Envelope. Generally the design will result in Level 1 flying qualities in some regions and, perhaps, Level 2 or Level 3 in others. Augmentation of one form or another (aerodynamic configuration changes, response feedback, control feedforward, signal shaping, etc.) would be incorporated to bring flying qualities up to Level 1 in the Operational Flight Envelope and to Level 2 in the Service Flight Envelope.

Initial Evaluation: The reliability and failure mode analyses are next performed to evaluate the nominal system design evolved above. All aircraft subsystem failures that affect flying qualities are considered. Failure rate data for these analyses may be those specified in the related specifications, other data with supporting

substantiation and approval as necessary, or specific values provided by the procuring agency. Prediction methods used will be in accordance with related specifications. The results of this evaluation will provide:

- a) a detailed outline of design points that are critical from a flying qualities/flight safety standpoint,
- b) quantitative predictions of the probability of encountering Level 2 in a single flight within the Operational Envelope, Level 3 in the Operational Envelope, and Level 3 in the Service Envelope, and
- c) recommend airframe/equipment changes to improve flying qualities or increase subsystem reliability to meet the specification requirements.

It should be noted that the flying qualities/flight safety requirements are concerned with failure mode effects, while other specifications provide reliability requirements per se (all failures regardless of failure effects). In the event of a conflict, the most stringent requirement should apply.

Re-Evaluation: As the system design progresses, the initial evaluation is revised at intervals. This process continues throughout the design phase. The results of the analyses of vehicle flying qualities/flight safety may be used to:

- a) establish flight test points that are critical and should be emphasized in the flight test program,
- b) establish pilot training requirements for the most probable, and critical, flight conditions, and
- c) provide guidance and requirements for other subsystem designs.

Proof of compliance is, for the most part, analytical in nature as far as probabilities of failure are concerned. However, some equipment failure rate data may become available during final design phases and during flight test, and any data from these or other test programs should be used to further demonstrate compliance. Stability

and control data of the usual type (e.g., predictions, wind tunnel, flight test) will also be used to demonstrate compliance. Finally, the results of all analyses and tests will be subject to normal procedures of procuring agency approval.

In summary, the Level concept was evolved in recognition of the obvious fact that flying qualities, flight safety, and system reliability are all very much related in the development of current piloted aircraft. This interrelationship is being exploited to improve aircraft in terms of overall effectiveness.

Special Failures

Note that certain Special Failure States (2.1.5.4) may be approved; these Failure States need not be considered in determining the probability of encountering degradation to Level 3. This allows each catastrophic failure possibility to be considered on its own. Requiring approval for each Special Failure State gives the procuring activity an opportunity to examine all the pertinent survivability and vulnerability aspects of each design. Survivability and vulnerability are important considerations, but it has not yet been possible to relate any specific flying qualities requirements to them.

Specific Failures

There are some specific requirements pertaining to failure of the engines and the flight control system (e.g., 3.7). For these requirements the specific failure is assumed to occur (with a probability of 1), with other failures considered at their own probabilities. For all other requirements, the actual probabilities of engine and flight control system failure are to be accounted for in the same manner as for other failures.

Feedback from engineers in the Air Force Aeronautical Systems Division who have experience in using MIL-F-8785B indicates a trend toward satisfying the Level requirements for failure states by specific failure analysis, i.e., assume a failure will happen if it possibly can. Furthermore, failures are assumed to occur at the most critical flight condition, and in the most critical way. Selection of failure states is based on preliminary analyses and the associated design considerations are dictated by the System Program Office. This approach may be extended to attach specific probability limits to Levels 1, 2 and 3, reaching agreement with the reliability and flight safety people along the lines that:

- Satisfactory mission performance demands Level 1 flying qualities in the Operational Flight Envelope. Deterioration to worse than Level 1 flying qualities will be considered to preclude mission accomplishment. (Although some mission capability remains at Level 2, that capability is degraded).
- Flight safety demands Level 3 or better flying qualities. Any deterioration to worse than Level 3 flying qualities will be included as a contributor to flight safety unreliability. (For landing, consider Level 2).
- Effects of failures on flying qualities will be accounted for in this manner for calculation of mission accomplishment reliability and flight safety reliability for comparison to the overall requirements.
- Questions arising with regard to mission capability or flight safety in the event of any particular failure or combination of failures will be referred to the procuring activity's flying quality specialists for resolution.
- Additionally, the flying qualities specification may (will) list specific failure cases for which a specified Level of flying qualities is required.

This alternative relieves the flying qualities people of the chore of reliability calculation. With proper interorganizational liaison, it should work where mission accomplishment and flight safety reliability are separately specified. The probability failure analysis has the appearance of being scientific (even if the numbers used result from art), whereas the specific failure analysis has the appearance of being simple (even if supported by involved analytical efforts). In truth, both approaches require sound engineering judgement backed by whatever data and analysis is available. The critical failure states and flight conditions must be identified, together with their impact on flying qualities. The end product should still be an aircraft in which the effects of failures are consistent with the mission requirements.

2.4.4 Explanatory Notes Concerning Application of Levels

2.4.4.1 Conceptual Diagrams of Design Evaluation Process

The design evaluation process is illustrated by the conceptual diagrams shown in Figures 2.4-4 and 2.4-5.

2.4.4.2 Theoretical Compliance

Part of the intent of 2.4.3 is to ensure that the probability of encountering significantly degraded flying qualities because of component or subsystem failures is small.

To determine theoretical compliance with the requirements of 2.4.3, the following steps must be performed:

- a) Identify those Rotorcraft Failure States which have a significant effect on flying qualities (2.1.5.2).
- b) Define the longest flight duration to be encountered during operational missions.
- c) Determine the probability of encountering various Rotorcraft Failure States, per flight, based on the above flight duration (2.4.3).
- d) Determine the degree of flying qualities degradation associated with each Rotorcraft Failure State in terms of Levels as defined in the specific requirements.
- e) Determine the most critical Rotorcraft Failure States (assuming the failures are present at whichever point in the Flight Envelope being considered is most critical in a flying qualities sense), and compute the total probability of encountering Level 2 flying qualities in the Operational Flight Envelope, etc.

- f) Compare the computed values above with the requirements in 2.4.3. An example which illustrates an approximate estimate of the probabilities of encounter follows: if the failures are all statistically independent, determine the sum of the probabilities of encountering all Rotorcraft Failure States which degrade flying qualities to Level 2 in the Operational Envelope. This sum must be less than 10^{-2} per flight.

If the requirements are not met, the designer must consider alternate courses such as:

- a) Improve the rotorcraft flying qualities associated with the more probable Failure States, or
- b) Reduce the probability of encountering the more probable Failure States through equipment redesign, redundancy, etc.

Regardless of the probability of encountering any given Rotorcraft Failure States (with the exception of Special Failure States) the flying qualities shall not degrade below Level 3.

2.4.4.3 Definitions of Level Regions

To determine the degradation in flying qualities parameters for a given Rotorcraft Failure State the following definitions are provided:

- a) Level 1 region is better than or equal to the Level 1 boundary, or number, given in the design criteria.
- b) Level 2 region is worse than Level 1, but no worse than the Level 2 boundary, or number.
- c) Level 3 region is worse than Level 2, but no worse than the Level 3 boundary, or number.

When a given boundary, or number, is identified as Level 1 and Level 2, this means that flying qualities outside the boundary conditions shown, or worse than

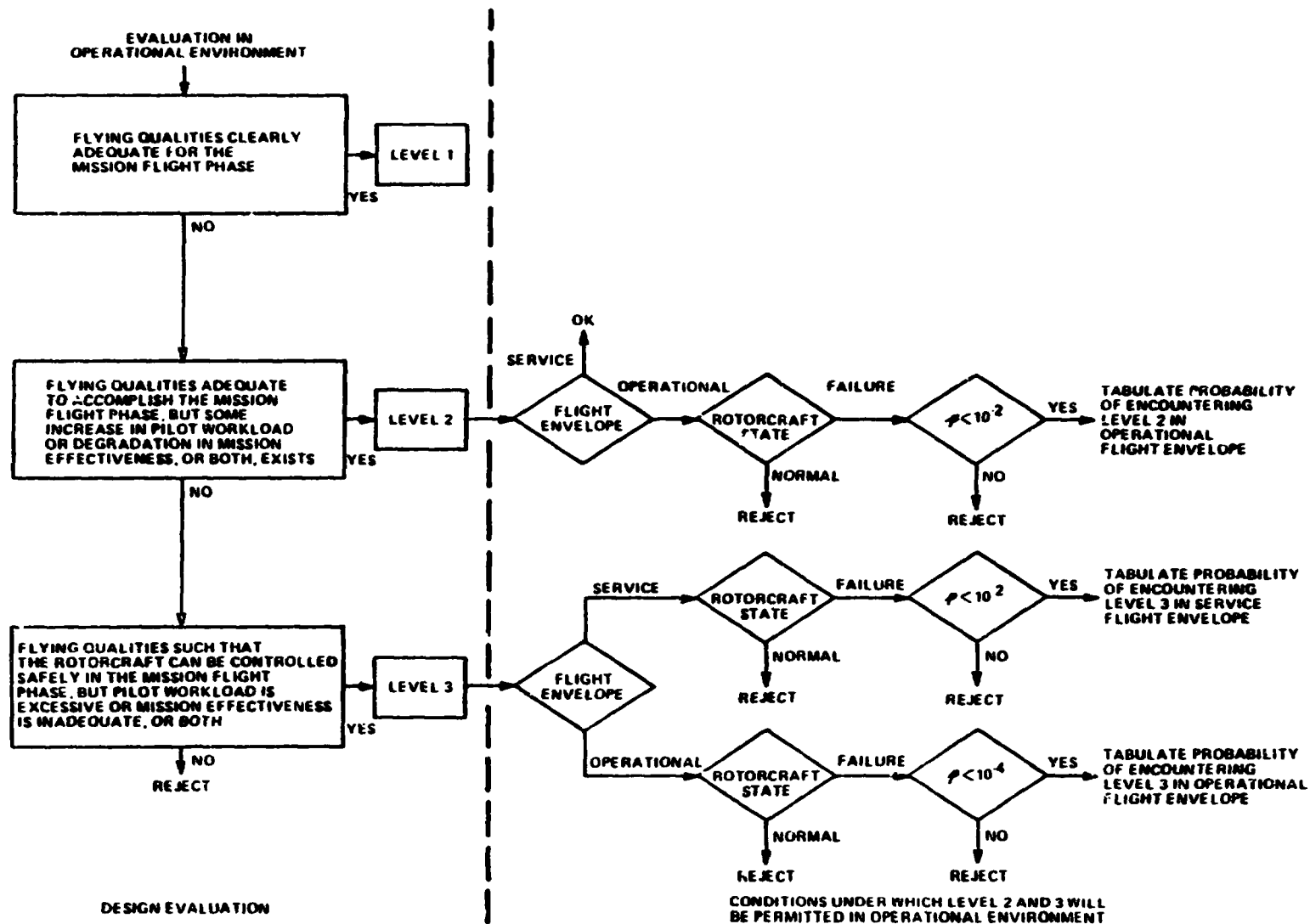

Figure 2.4-4 DEFINITION OF CONDITION UNDER WHICH LEVEL 2 AND 3 FLYING QUALITIES WILL BE PERMITTED IN THE OPERATIONAL ENVIRONMENT

B-67

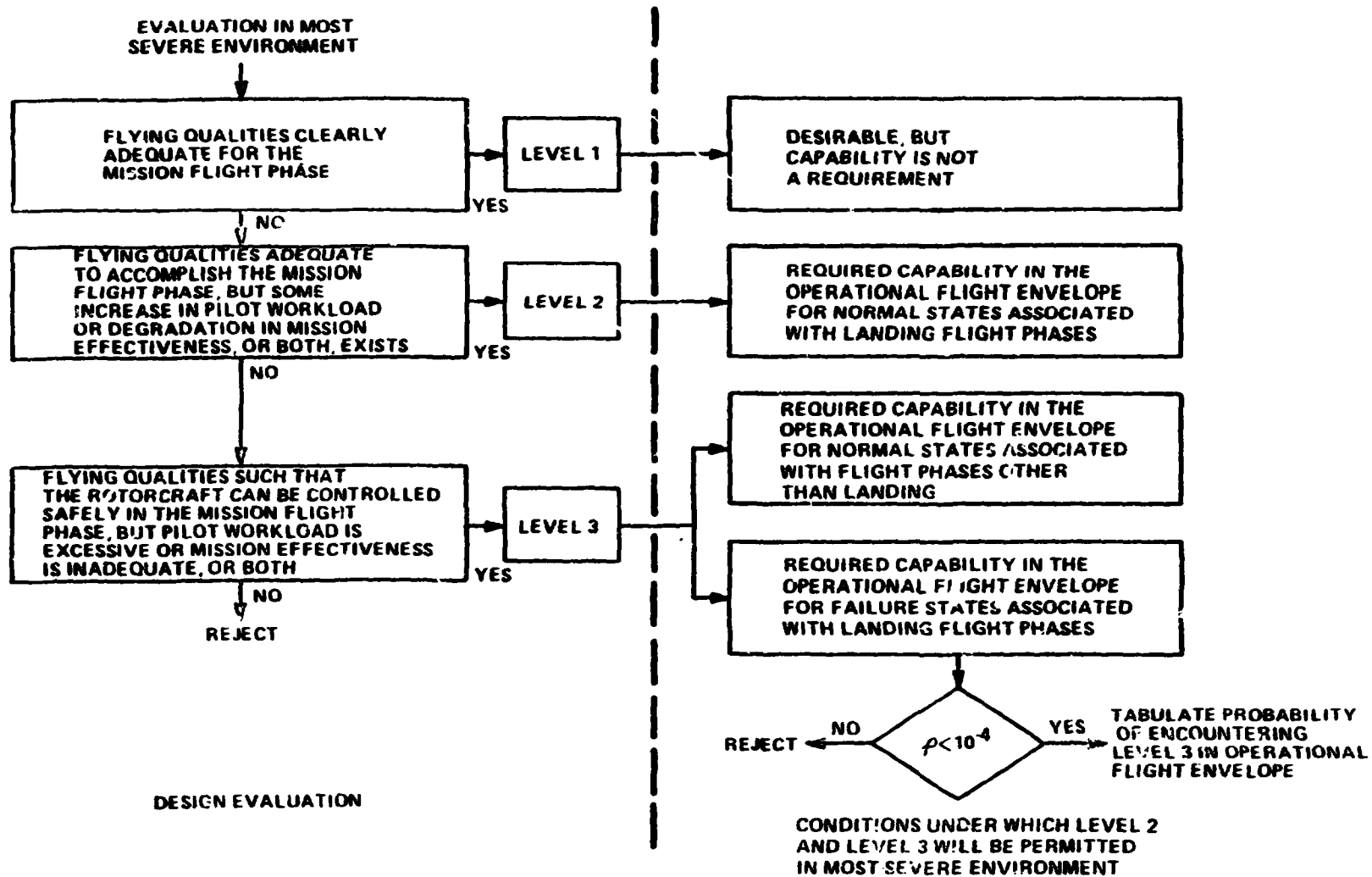

Figure 2.4-5 DEFINITION OF CONDITION UNDER WHICH LEVEL 2 AND LEVEL 3 FLYING QUALITIES WILL BE PERMITTED IN THE MOST SEVERE ENVIRONMENT

the number given, are at best Level 3 flying qualities. Also, since Level 1 and Level 2 requirements are the same, flying qualities must be within this common boundary, or number, in both the Operational and Service flight Envelopes for Rotorcraft Normal States (2.4.2). Rotorcraft Failure States that do not degrade flying qualities beyond this common boundary are not considered in meeting the requirements of 2.4.3. Rotorcraft Failure States that represent degradations to Level 3 must, however, be included in the computation of the probability of encountering Level 3 degradations in both the Operational and Service Flight Envelopes. Again degradation beyond the Level 3 boundary is not permitted regardless of component failures.

2.4.4.4 Computational Assumptions

Assumptions a) and b) of 2.4.3 are somewhat conservative, but they simplify the required computations in 2.4.3 and provide a set of workable ground rules for theoretical predictions. The reasons for these assumptions are:

- a) "...components and systems are ... operating for a time period per flight equal to the longest operational mission time ...". Since most component failure data are in terms of failures per flight hour, even though continuous operation may not be typical (e.g., yaw damper ON during hovering flight only), failure probabilities must be predicted on a per flight basis using a "typical" total flight time. The "longest operational mission time" as "typical" is a natural result. If acceptance cycles-to-failure reliability data are available, these data may be used for prediction purposes based on maximum cycles per operational mission. In any event, compliance with the requirements of 2.4.2 is based on the probability of encounter per flight.
- b) "...failure is assumed to be present at whichever point ... is most critical ...". This assumption is in keeping with the requirements of 2.1.5.2 regarding Flight Phases subsequent to the actual failure in question. In cases that are unrealistic from the operational standpoint, the specific Rotorcraft Failure States might fall in the Rotorcraft Special Failure State classification (2.1.5.3).

2.5 APPLICABLE DOCUMENTS

3 FLYING QUALITIES REQUIREMENTS FOR CLASS I

Requirements for Operational Capability Class I are included in Appendix A, however, Background Information and Users Guide material to support these requirements was not prepared under the Calspan Phase I contract effort.

3.9 ENVIRONMENTAL CONDITIONS

Unless otherwise specified by the procuring activity for a specific procurement, the environmental conditions defined in this section describe the environments in which the rotorcraft must be designed to operate. These environmental conditions will be used to evaluate the flying qualities through analysis, simulation and flight test.

DISCUSSION

The wording of 2.3 is such that the procuring activity is charged with responsibility for defining the environmental conditions in which the rotorcraft is to be designed to operate. These conditions are to be defined for each Flight Phase. During the process of defining the environmental conditions, the procuring activity should consider the mission requirements for the particular procurement. Section 3.9 of the specification contains a catalog of models, parameter magnitudes and references which can be used by the procuring activity as background information when developing the Operational and Most Severe Environment definitions for a specific procurement. In the event the procuring activity does not provide specific guidance, the contractor is directed to use the environment definitions of 3.9 to design and evaluate the rotorcraft.

3.9.1 Continuous turbulence models

Two model forms for describing continuous random turbulence are defined. Either model may be used in the process of designing and evaluating the rotorcraft flying qualities. The von Karman form of the spectra for the turbulence velocities is:

$$\begin{aligned}\phi_{u_g}(\Omega) &= \sigma_u^2 \frac{2L_u}{\pi} \frac{1}{[1 + (1.339 L_u \Omega)^2]^{5/6}} \\ \phi_{v_g}(\Omega) &= \sigma_v^2 \frac{2L_v}{\pi} \frac{1 + 8/3(2.678 L_v \Omega)^2}{[1 + (2.678 L_v \Omega)^2]^{11/6}} \\ \phi_{w_g}(\Omega) &= \sigma_w^2 \frac{2L_w}{\pi} \frac{1 + 8/3(2.578 L_w \Omega)^2}{[1 + (2.678 L_w \Omega)^2]^{11/6}}\end{aligned}$$

The Dryden form of the spectra for the turbulence velocities is:

$$\begin{aligned}\phi_{u_g}(\Omega) &= \sigma_u^2 \frac{2L_u}{\pi} \frac{1}{1 + (L_u \Omega)^2} \\ \phi_{v_g}(\Omega) &= \sigma_v^2 \frac{2L_v}{\pi} \frac{1 + 12(L_v \Omega)^2}{[1 + 4(L_v \Omega)^2]^2} \\ \phi_{w_g}(\Omega) &= \sigma_w^2 \frac{2L_w}{\pi} \frac{1 + 12(L_w \Omega)^2}{[1 + 4(L_w \Omega)^2]^2}\end{aligned}$$

where: $\Omega = \omega/V_T$ and V_T is True Airspeed but not less than 35 Knots

DISCUSSION

Continuous turbulence models of the Von Karman and Dryden form are defined. These models are of the basic form introduced in Ref. B-1 & B-2. The definitions of parameters in the models have been revised as recommended in Ref. B-3. This revision is necessary to make the turbulence models of the one-dimensional spectra satisfy all the mathematical requirements for isotropic atmospheric turbulence.

For isotropic turbulence, the characteristics of the one-dimensional spectra are related by

$$\sigma^2 = \sigma_u^2 = \sigma_v^2 = \sigma_w^2$$

and

$$L = L_u = 2 L_v = 2 L_w$$

In isotropic turbulence, the three longitudinal scales are all equal, the six lateral scales are all equal, and the longitudinal scales equal twice the lateral scales. Longitudinal and lateral here refer to the gust field, not the aircraft. When considering one-dimensional spectra, there is one longitudinal scale in the direction of the spatial frequency (L_u), and the other two scales (L_v and L_w) are lateral scales. This point is frequently confused. The equations defining the Von Karman and Dryden turbulence spectra presented in 3.9.1 are derived from those introduced in Ref. B-1 by substituting $2 L_v$ for L_v and $2 L_w$ for L_w . The numerical values of the terms will remain the same because the definitions of L_v and L_w presented in 3.9.1.1 also involve a factor of two.

3.9.1.1 Scale lengths. The scale lengths for use in the continuous random turbulence models of 3.9.i are defined as functions of altitude.

von Karman Model

$$\text{Above } h = 2500 \text{ ft} \quad L_U = 2 \quad L_V = 2 \quad L_W = 2500 \text{ feet}$$

$$\text{Below } h = 2500 \text{ ft} \quad L_U = 2 \quad L_V = 184 h^{1/3} \text{ feet}$$

$$2 L_W = h \text{ feet}$$

Dryden Model

$$\text{Above } h = 1750 \text{ ft} \quad L_U = 2 \quad L_V = 2 \quad L_W = 1750 \text{ feet}$$

$$\text{Below } h = 1750 \text{ ft} \quad L_U = 2 \quad L_V = 145 h^{1/3} \text{ feet}$$

$$2 L_W = h \text{ feet}$$

DISCUSSION

The scale length definitions are taken from Ref. B-3. The definitions are basically those introduced in Refs. B-1 & B-2 except L_V and L_W are replaced by $2 L_V$ and $2 L_W$.

3.9.1.2 RMS intensities. The root-mean-square intensities $\sigma_u = \sigma_v$ to be used in the continuous random turbulence models of 3.9.1 are defined in Table 3.9-1.

Table 3.9-1
 σ_u AND σ_v INTENSITIES

Environment	$h < 2500/1750$ ft	$h > 2500/1750$ ft
Operational	$\sigma_u = 6$ ft/sec	$\sigma_u = 6$ ft/sec
Most Severe	$\sigma_u = 10$ ft/sec	$\sigma_u = 20$ ft/sec

The magnitude of σ_w is a function of σ_u and the scale length definitions as follows.

von Karman Model

Dryden Model

$$\frac{\sigma_u^2}{L_u^{2/3}} = \frac{\sigma_v^2}{(2L_v)^{2/3}} = \frac{\sigma_w^2}{(2L_w)^{2/3}}$$

$$\frac{\sigma_u^2}{L_u} = \frac{\sigma_v^2}{2L_v} = \frac{\sigma_w^2}{2L_w}$$

Below $h = 2500$ ft. for the von Karman model and below $h = 1750$ ft. for the Dryden model, the magnitude of σ_w is a function of altitude.

von Karman Model

Dryden Model

$$\sigma_w = \frac{h^{2/3}}{\sqrt[3]{184}} \sigma_u$$

$$\sigma_w = \frac{h^{1/3}}{\sqrt{145}} \sigma_u$$

$h < 2500$ feet

$h < 1750$ feet

DISCUSSION

Although the Von Karman and Dryden forms of the spectra for turbulence velocities are used in Ref's B-1 through B-6. The definitions of the RMS turbulence intensities in the various documents are significantly different. The differences in the RMS intensities specified are not only a result of different choices for selecting the magnitude of one of the components (e.g. Ref. B-1 specifies σ_w in a plot as a function of

altitude; Ref. B-4 specifies σ_w to be 10 percent of the mean wind speed at 20 ft altitude but also the intensities are interrelated through the scale length definitions and the equations relating scale length and the RMS intensities. Examples of the definitions of scales and intensities specified in Ref. B-4, B-6 and the Calspan recommendation for MIL-H-8501 are shown in Figures B-1. The comparison shows that there are factors of 2 and $\sqrt{2}$ in the definitions of parameters and that the parameters are different function of altitude in the different references. The variation of the RMS intensities with altitude are illustrated in Figure B-2. MIL-F-8785C has σ_w constant with altitude and $\sigma_u = \sigma_v$ increase as the ground is approached. This seems counter to the boundary constraint that the vertical velocity should decrease to zero at the runway surface. The MIL-STD Draft and the Calspan proposal have σ_u specified independent of altitude and the magnitude of σ_w decreases as a cubic function of altitude. The MIL-STD Draft has $\sigma_v = \sqrt{2} \sigma_u$ rather than $\sigma_v = \sigma_u$ as in the Calspan proposal. The $\sqrt{2}$ factor results from different definitions of the scale lengths in the Calspan Proposal and the MIL-STD Draft. It is believed that the Calspan proposal for MIL-H-8501 has the "correct" definitions of scales.

$$L_u = 2 L_w = 2 L_v$$

and the "correct" relationship between scales and RMS intensities; e.g. for the Dryden model

$$\frac{\sigma_u^2}{L_u} = \frac{\sigma_v^2}{2L_v} = \frac{\sigma_w^2}{2L_w}$$

Thus

$$\begin{aligned} \sigma_u &= \sigma_v \\ \sigma_w &= .083 h^{1/3} \sigma_u \end{aligned}$$

when the definitions of scales

$$\begin{aligned} L_u &= 2 L_v = 145 h^{1/3} \\ 2 L_w &= h \end{aligned}$$

are applied.

SCALES AND RMS INTENSITIES

MIL-F-8785C

$$\begin{aligned} \sigma_w &= 0.1 U_{20} \\ \sigma_u &= \sigma_v = \frac{\sigma_w}{(0.177 + .000823h)^{0.4}} && \text{BELOW 1000 FT} \\ L_u &= L_v = \frac{h}{(0.177 + .000823h)^{1.2}} && 10 < h < 1000 \text{ FT} \\ L_w &= h \end{aligned}$$

MIL-STD

$$\begin{aligned} \sigma_u &= 5 \text{ FT/SEC } \sim \text{MODERATE} \\ \sigma_w &= .117 h^{1/3} \sigma_u && 10 < h < 1750 \text{ FT} \\ \frac{\sigma_u^2}{L_u} &= \frac{\sigma_v^2}{2L_v} \quad \text{THUS } \sigma_v = \sqrt{2} \sigma_u \\ L_u &= L_v = 145 h^{1/3} && 10 < h < 1750 \text{ FT} \\ L_w &= h \end{aligned}$$

CALSPAN

$$\begin{aligned} \sigma_u &= 6 \text{ FT/SEC OPERATIONAL} \\ \sigma_w &= .083 h^{1/3} \sigma_u && h < 1750 \text{ FT} \\ \sigma_v &= \sigma_u \\ L_u &= 2L_v = 145 h^{1/3} && h < 1750 \text{ FT} \\ 2L_w &= h \end{aligned}$$

Figure B-1 DRYDEN MODEL

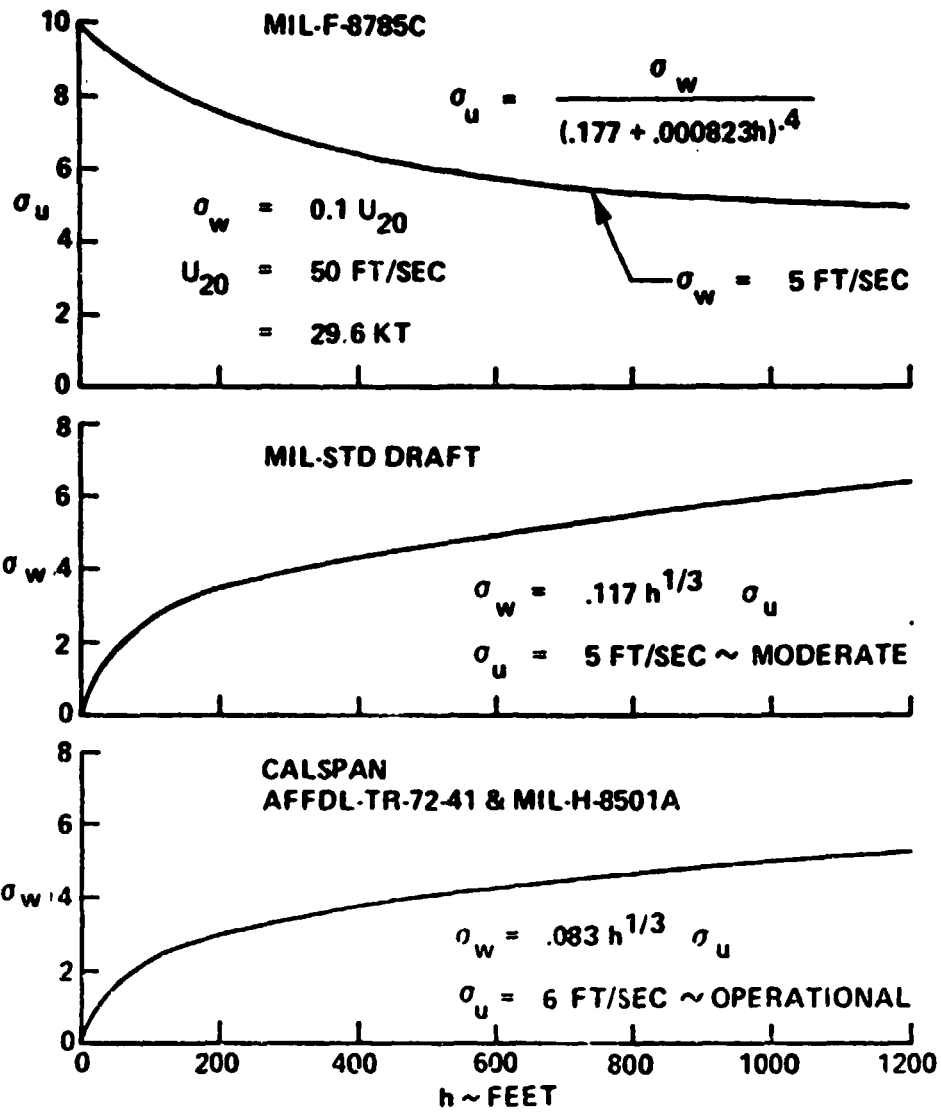

Figure B-2 DRYDEN MODEL RMS INTENSITIES

In the Calspan proposal, the $\sigma_u = \sigma_v$ RMS is specified for the Operational Environment and for the Most Severe Environment. A larger value of σ_u is specified for the Most Severe Environment when altitude is greater than 2500 feet for the Von Karman model and greater than 1750 feet for the Dryden Model. The higher RMS is specified for the Most Severe Environment at the higher altitude because it was considered that the probability of encountering thunderstorm activity is higher above 2500 or 1750 feet altitude.

The choice of magnitude of one of the RMS velocity components to use in the specification should be a function of the intended operational use of the rotorcraft for each procurement. This choice will be based on statistical data developed to describe the characteristics of the atmosphere during different seasons, weather conditions, terrain features etc. Terminology and magnitudes of RMS velocities used to characterize turbulence in previous specification documents are presented in Figure B-3. The values of σ_u selected by Calspan for the Operational and Most Severe Environments are related to data defining the relative frequency distribution of RMS gust velocities in Figure B-4 and to exceedance probabilities in Figure B-5. Figures B-4 & B-5 are taken from Ref. B-2.

MIL-F-8785B	LOW ALTITUDE	
CLEAR AIR	$\sigma_w = 6.7$ FT/SEC	
THUNDERSTORM	= 21 FT/SEC	
MIL-F-8735C	LOW ALTITUDE	MEDIUM/HIGH ALTITUDE
$\sigma_w = .1 U_{20}$	σ_w	σ_w h = 10 KFT
LIGHT (WIND)	2.53 FT/SEC	5 FT/SEC
MODERATE	5.07	10
SEVERE	7.61	21
BRITISH AvP970		MIL-STD DRAFT
LIGHT	$\sigma_w = 3$ FT/SEC	LIGHT $\sigma_u = 3$ FT/SEC
MODERATE	5	MODERATE 5
HEAVY	10	SEVERE 10
EXTREME	20	EXTREME 24
CALSPAN	h < 1750 FT	h > 1750 FT
ENVIRONMENTS	σ_u	σ_u
OPERATIONAL	6 FT/SEC	6 FT/SEC
MOST SEVERE	10	20

Figure B-3 RMS TURBULENCE CHARACTERIZATIONS

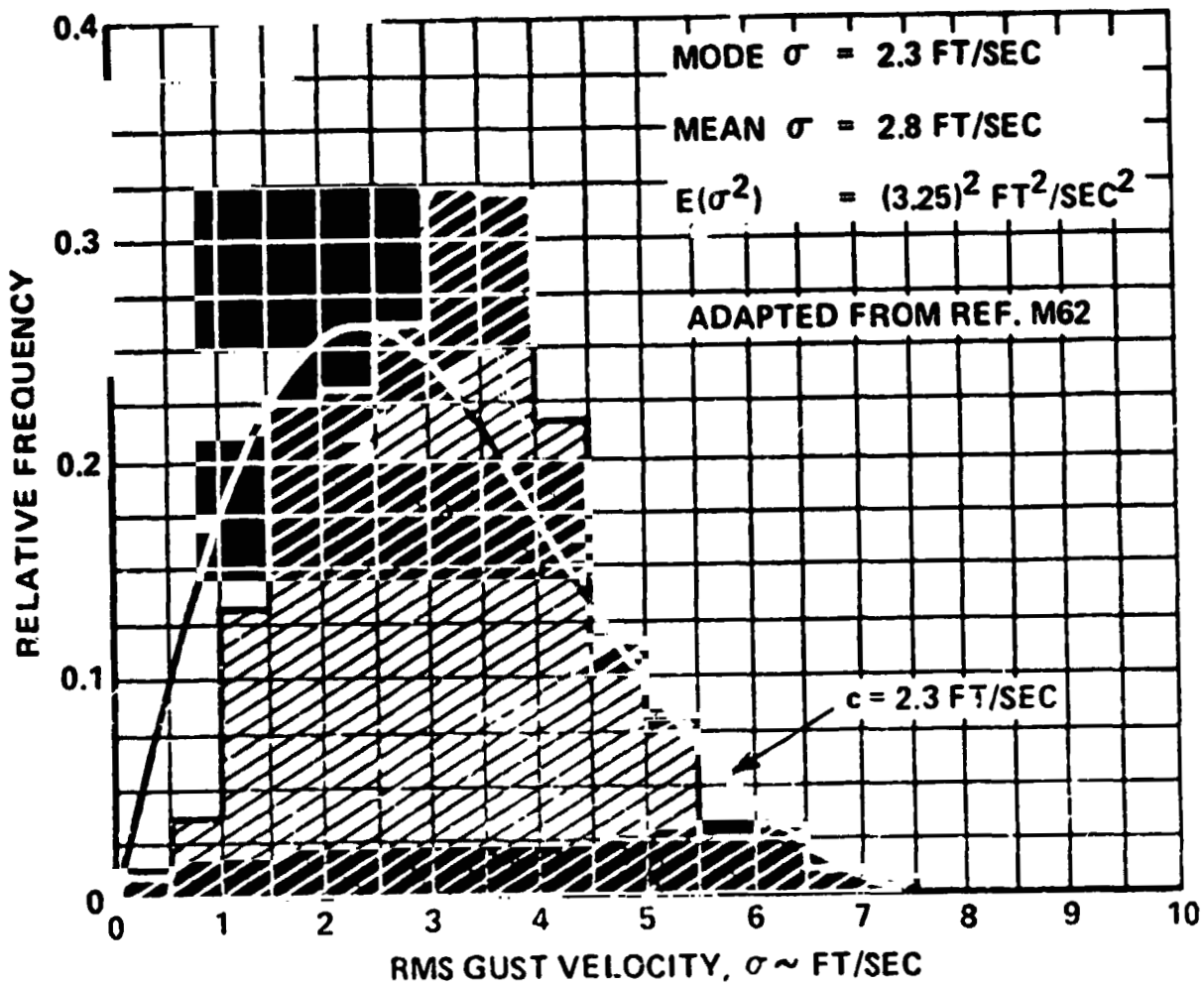

Figure B-4 RELATIVE FREQUENCY DISTRIBUTIONS OF RMS GUST VELOCITY FROM B-66 LOW-LEVEL LEVEL PROGRAM

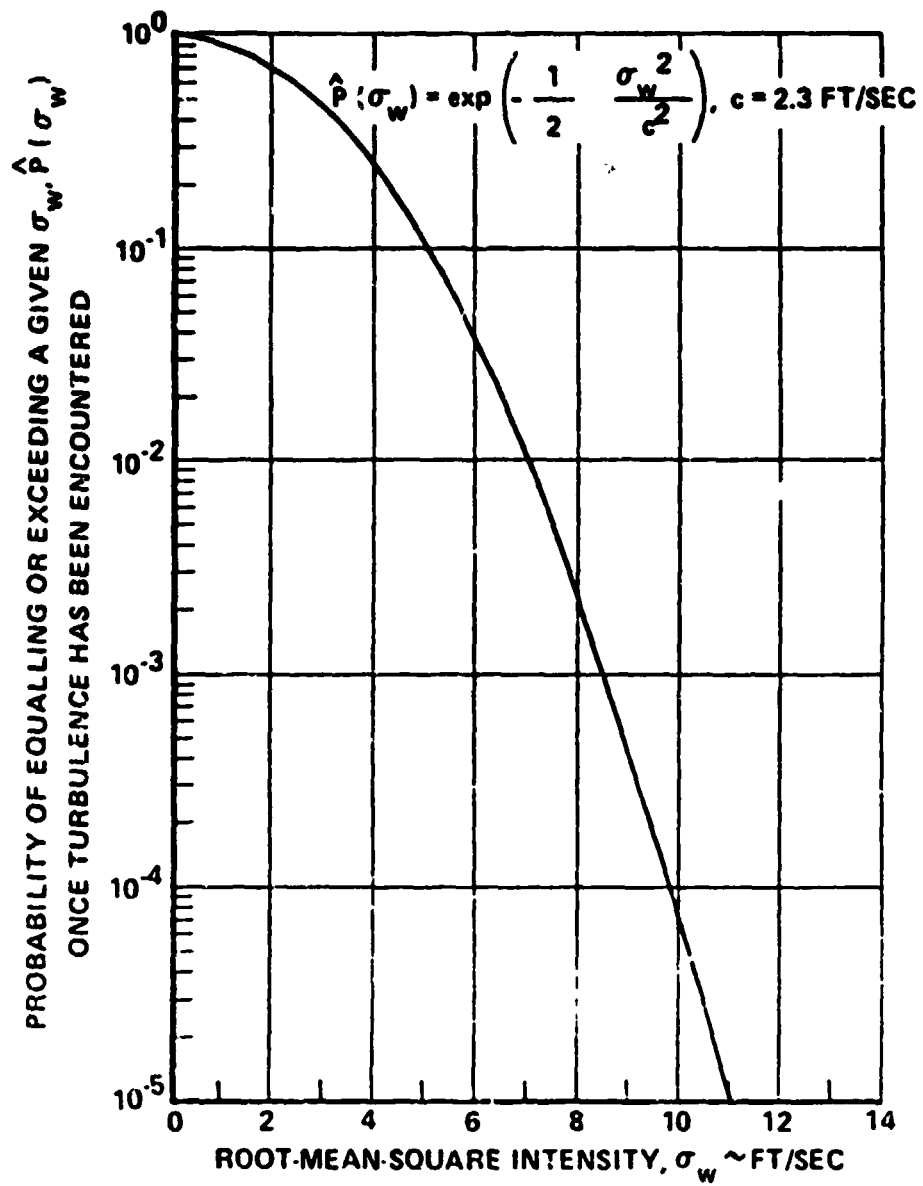

Figure B-5 EXCEEDANCE PROBABILITY

3.9.1.3 Application of the disturbance model in analyses. The gust and turbulence velocities shall be applied to the rotorcraft equations of motion through the aerodynamic terms only, and the direct effect on the aerodynamic sensors shall be included when such sensors are part of the rotorcraft augmentation system. When using the discrete gust model, all significant aspects of the penetration of the gust by the rotorcraft shall be incorporated in the analyses. Application of the disturbance model depends on the range of frequencies of concern in the analyses of the rotorcraft. When structural modes are significant, the exact distribution of turbulence velocities should be considered. For this purpose, it is acceptable to consider u_g and v_g as being one-dimensional functions only of x , but w_g shall be considered two-dimensional, a function of both x and y , for the evaluation of aerodynamic forces and moments.

When structural modes are not significant, rotorcraft rigid-body responses may be evaluated by considering uniform gust or turbulence immersion along with linear gradients of the disturbance velocities. The uniform immersion is accounted for by u_g , v_g , and w_g defined at the rotorcraft center of gravity. The angular velocities due to turbulence are equivalent to the aerodynamic effect of rotorcraft angular velocities. Approximations for these angular velocities are defined (precisely at very low frequencies only) as follows:

$$- \dot{\alpha}_g = q_g = \frac{\partial w_g}{\partial x}, \quad p_g = - \frac{\partial w_g}{\partial y}, \quad r_g = - \frac{\partial v_g}{\partial x}$$

The spectra of the angular velocity disturbances due to turbulence are then given by:

$$\phi_{p_g}(\Omega) = \frac{J_w^2}{L_w} \frac{0.4 \left(\frac{\pi L_w}{4b} \right)^{1/3}}{1 + \left(\frac{4b}{\pi} \Omega \right)^2}, \quad \phi_{q_g}(\Omega) = \frac{\Omega^2}{1 + \left(\frac{4b}{\pi} \Omega \right)^2} \phi_{w_g}(\Omega), \quad \phi_{r_g}(\Omega) = \frac{\Omega^2}{1 + \left(\frac{3b}{\pi} \Omega \right)^2} \phi_{v_g}(\Omega)$$

where b = wing span or the rotor diameter whichever is greater. The turbulence components, u_g , v_g , w_g , and p_g shall be considered mutually independent (uncorrelated) in a statistical sense. However, q_g is correlated with w_g , and r_g is correlated with v_g . For the discrete gusts the linear gradient gives angular velocity perturbations of the form:

$$p_g = p_m \sin \frac{\pi x}{d_m} \quad 0 \leq x \leq d_m$$

For the low-altitude model, the turbulence velocity components, u_g , v_g , and w_g are to be taken along axes with u_g aligned along the relative mean wind vector and w_g vertical.

DISCUSSION

This requirement is essentially the same as that in Ref. B-2 with notation correction in the expression for ϕ_{pg} . Discussions of factors to consider during application of the disturbance models in analysis and simulation are contained in Reference: B-2, B-3, B-5 and B-6. Also see the discussion of Environment Models in Section 4.1 of this report.

3.9.2 Discrete gust model

The discrete gust model may be used for any of the three gust-velocity components and, by derivation, any of the three angular components.

The discrete gust has the "1-cosine" shape given by:

$$v = 0 \quad , \quad x < 0$$

$$v = \frac{v_m}{2} \left(1 - \cos \frac{\pi x}{d_m} \right) \quad , \quad 0 \leq x \leq d_m$$

$$v = v_m \quad , \quad x > d_m$$

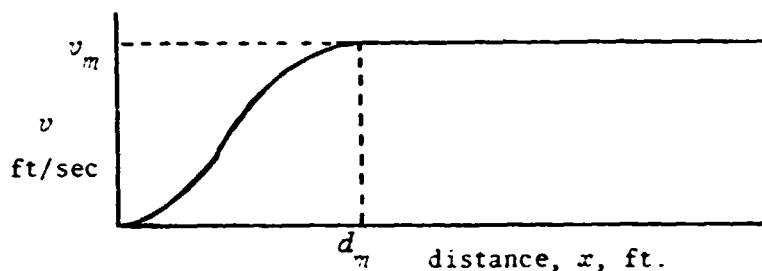

The discrete gust above may be used singly or in multiples in order to assess rotorcraft response to, or pilot control of, large disturbances. Step function or linear ramp gusts may also be used.

3.9.2.1 Gust lengths. Several values of d_m shall be used, each chosen so that the gust is tuned to each of the natural frequencies of the rotorcraft and its flight control system (higher-frequency structural modes may be excepted). For the Severe intensities, modes with wavelengths less than the turbulence scale length may be excepted.

3.9.2.2 Gust magnitudes. The gust magnitudes u_g , v_g , and w_g shall be determined from Figure 3.9-1 using values of d_m from 3.9.2.1 and values of σ_u , σ_v and σ_w from 3.9.1.2. Microbursts or downbursts, i.e. short-lived vertical downdrafts can occur at altitudes below 300 feet. These may be represented by a full (1-cos) function with $V_m = -30$ ft/sec and $d_m = 1800$ ft where d_m is horizontal distance.

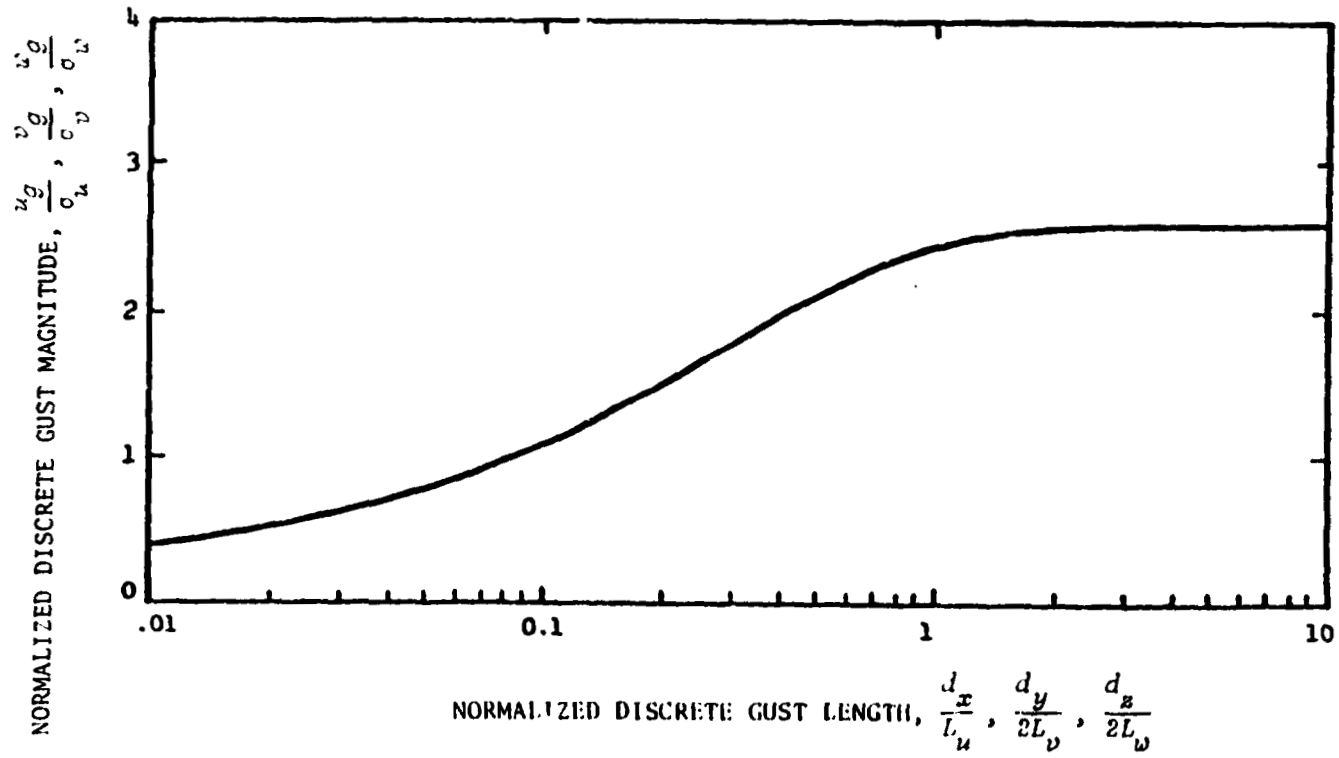

Figure 3.9-1 MAINTENANCE OF DISCRETE GUSTS

DISCUSSION

The (1-cosine) discrete gust model was introduced in Refs. B-1 and B-2. The form was changed in Reference B-4 and B-5 to permit approximations to "step" gusts as well as "pulse" gusts. The Reference B-4 form of the discrete gust model is adopted by Calspan for the rotorcraft specification. Notation changes resulting from the scale definitions have been incorporated in Figure 3.9-1. The discussions relating to this requirement in Ref's B-2 and B-5 are appropriate background information.

Paragraph 3.9.2.2 contains a definition of a microburst or downdraft typical of vertical wind profiles under thunderstorms. The magnitude of the peak downdraft velocity and the horizontal dimension of the downdraft is based on data contained in Ref. B-7. In reality, the air motions associated with microbursts and thunder storm downbursts are more complex and involve air velocities along the three coordinate axes. Further description of air velocities measured in the Joint Airport Weather Studies (JAWS) project are contained in Ref. B-8.

3.9.3 Mean wind model

The mean wind speed variation with altitude, above the ground, is defined by the following equation

$$V_w = V_o + G h \quad 0 < h < 300 \text{ feet}$$

The surface wind V_o is defined in Table 3.9-2.

Table 3.9-2
SURFACE WIND MAGNITUDE

Environment	V_o		
	Headwind	Crosswind	Tailwind
Operational	50 ft/sec	50 ft/sec	0 ft/sec
Most Severe	76 ft/sec	50 ft/sec	0 ft/sec

The wind speed is relative to the ground. The directions headwind, crosswind and tailwind refer to desired ground track. In vertical flight at zero ground speed, the wind directions refer to rotorcraft heading at zero altitude.

The wind gradient with altitude is defined in Table 3.9.2a.

Table 3.9-2a
WIND GRADIENT

Environment	G ft/sec Per Foot
Operational	.14
Most Severe	.34

DISCUSSION

Rotorcraft are frequently operated at low altitude with the flight path referenced to the ground and obstacles fixed to the ground. The motion of the air mass relative to the ground is of importance to the performance and flying qualities of the rotorcraft. Paragraph 3.9.3 contains a definition of the mean wind and wind gradient at altitude less than $h \leq 300$ ft for the Operational and Most Severe Environments. The mean wind magnitudes in Table 3.9-2 are consistent with the probability of exceedance data for mean wind speed at 20 ft. altitude contained in Figure 3.6 of Reference B-3. The wind gradient magnitudes in Table 3.9-2a are based on wind shear measurements or estimates which were extracted from the following periodicals.

<u>Source</u>	<u>Description</u>
"Wind Shear: The Mystery of the Vanishing Airspeed" The AOPA Pilot, November 1975	Wind Shear studies in Texas and Florida indicate: 4 kt/100 ft average gradients Low-level shear 10-15 kt/100 ft are not unusual. 35 kt/100 ft have been observed.
"Wind Shear Detection" Flight Operations, February 1976	Measured wind shear which occurred at JFK on 4 January 1971 and caused nine aircraft to execute missed approaches. Tail wind of 70 kt at 3000 ft. Cross wind of 25 kt at 1000 ft. Head wind of 10 kt at surface.
Accident Investigation Aviation Week, 14 April 1975	Iberian DC-10 Flt. 933 crash at Logan International on 17 December 1973. 18 kt tail wind changed to 3 kt headwind 23 kt cross wind decreased to 3 kt. Occurred between 500-300 ft in time interval of 20 sec. 7.1 kt/100 ft longitudinal, 6.3 kt/100 ft lateral.

"Wind Shear, The Super Hazard"
Business and Commercial Aviation
August 1976

Iberian DC-10 Flt. 933, wind at 1000 ft was 35 kt from 191°. It rotated clockwise 8 kt from 315° at the surface. Between 500-200 ft the headwind component increased 21 kt or an average shear of 7 kt/100 ft.

Wind shears average 3-5 kt/100 ft with extremes of 30 kt/100 ft.

"Wind Shear on Approach"
Shell Aviation News, 1971

Low altitude wind shears appear to have a variety of characteristics. Some representative examples (Figure 1) and their general characteristics are as follows:

- (a) Large magnitude shears up to 40 kt or more occurring over an altitude range from ground level to several hundred feet above the ground. Maximum rates of shear are on the order of 12 kt per 100 feet, and are highest near the ground. Many shears of lesser magnitudes will also have these general characteristics.

3.9.4 Tree-line wake

The mean wind speed variation with altitude in the lee of a line of closely spaced trees is defined in Figure 3.9-2. The wind direction is perpendicular to the tree line. The wind speed at 140 feet altitude is specified in Table 3.9-3.

Table 3.9-3
WIND SPEED AT 140 FT ALTITUDE

Environment	V_w at h = 140 ft
Operational	70 ft/sec
Most Severe	124 ft/sec

DISCUSSION

Wind tunnel tests have been performed to determine air velocity profiles near the edge of a forest. These tests have been performed as part of studies to determine how smoke and bacterial agents would be carried into a wooded area by the ambient wind. Tests have been performed on model boards with scaled trees. Figure B-6 is based on data in Ref. B-9. The tests have shown that the tree canopies cause a reduction in the horizontal wind velocity and that a jetting action occurs in the region of the tree trunks. This phenomena may cause difficulty for rotorcraft operations such as vertical takeoffs and descents or pick-up and placement of slung loads. The wind speed profile with altitude illustrated in Figure 3.9-2 is based on data in Ref. B-9 for a distance 1.7 times the tree height down stream of the tree line. The wind speeds at 140 ft altitude are consistent with the mean head wind magnitudes defined in paragraph 3.9.3 for the Operational and Most Severe Environments.

$$\begin{aligned} \text{Operational } V_w &= 50 + .14 (140) \\ &= 70 \text{ ft/sec} \end{aligned}$$

$$\begin{aligned} \text{Most Severe } V_w &= 76 + .34 (140) \\ &= 124 \text{ ft/sec} \end{aligned}$$

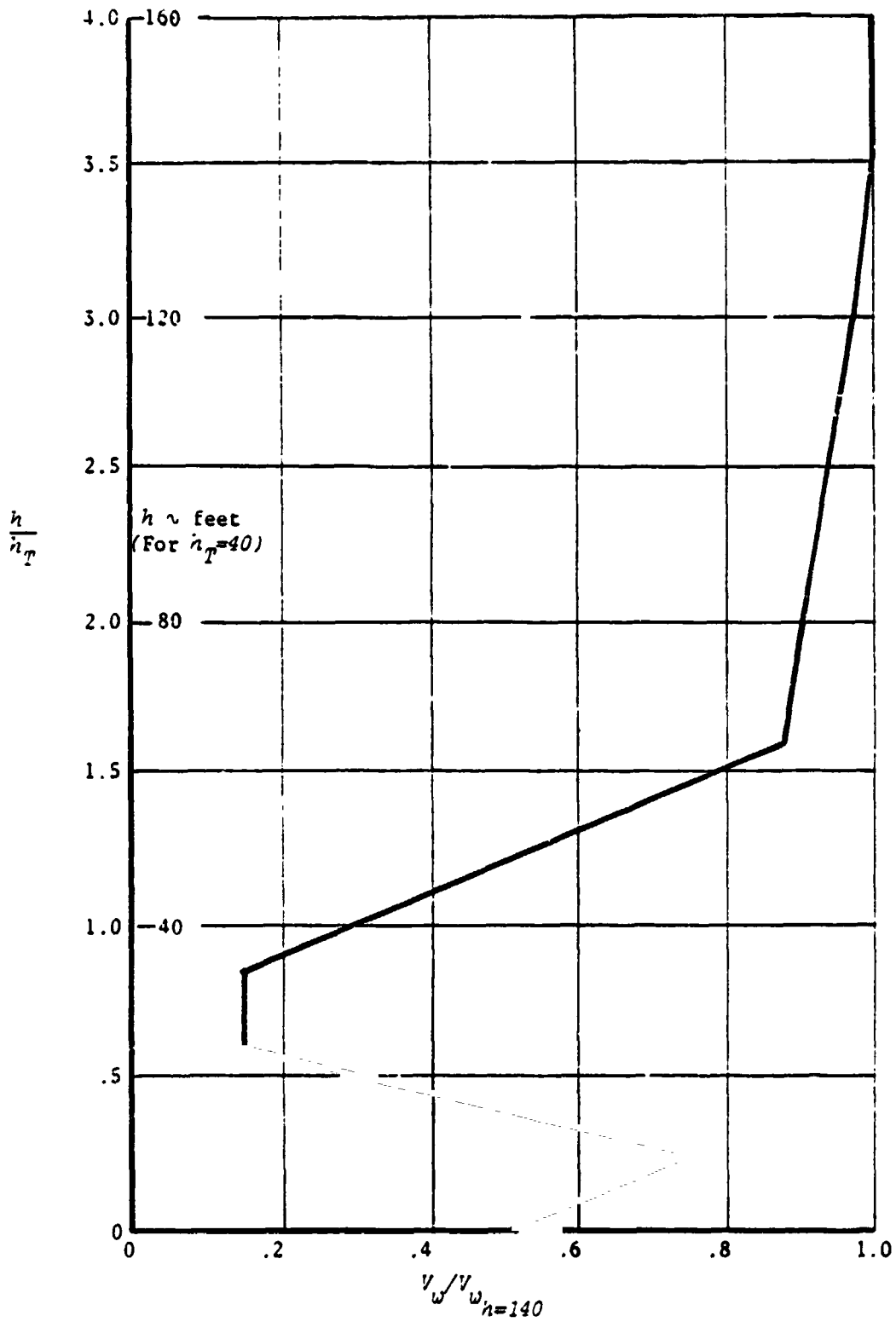

Figure 3.9-2 WIND SPEED BEHIND TREE-LINE

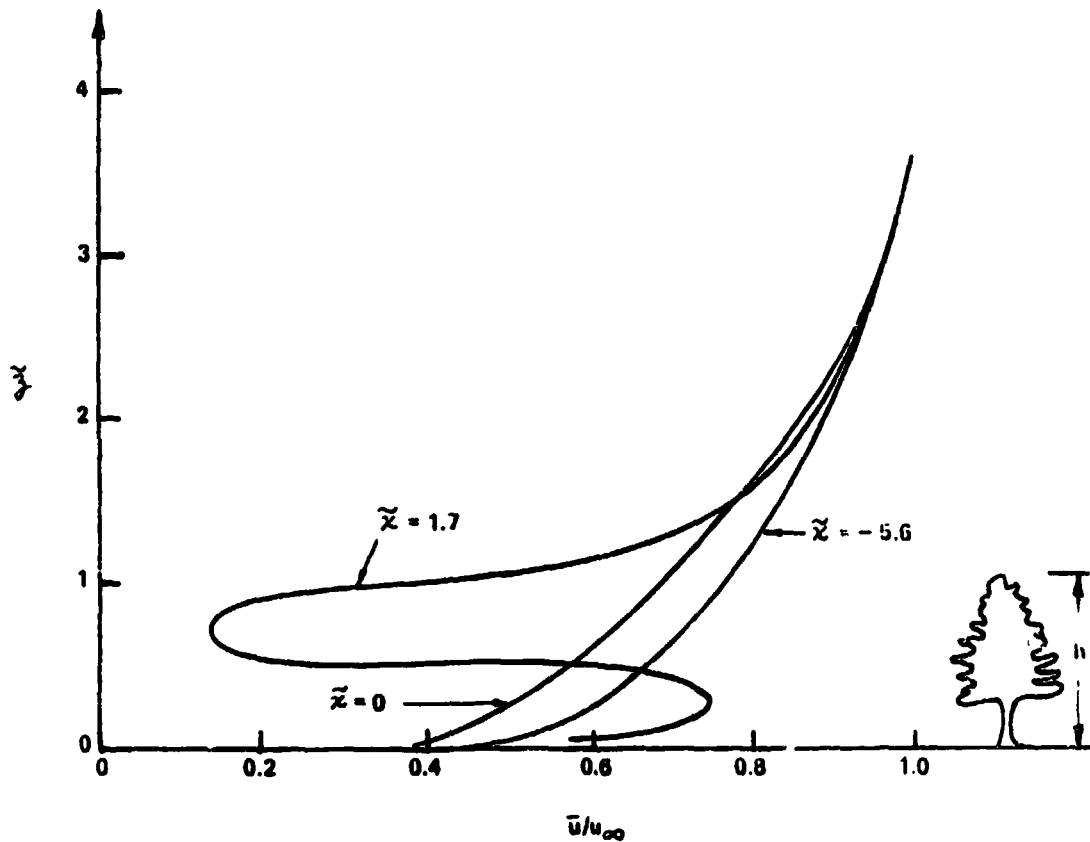

Figure B-6 NORMALIZED VELOCITY PROFILES NEAR THE EDGE OF A FOREST SHOWING THE JETTING ACTION IN THE REGION OF THE TRUNKS TREE SPACING $\approx h$

- h = HEIGHT OF TREES
- x = HORIZONTAL DISTANCE DOWNWIND OF EDGE OF FOREST
- $\tilde{x} = x/h$
- z = HEIGHT ABOVE FLOOR OF FOREST
- $\tilde{z} = z/h$
- \bar{u} = LOCAL MEAN VELOCITY
- u_{∞} = REFERENCE VELOCITY AT REFERENCE HEIGHT WELL ABOVE FOREST CANOPY

3.9.5 Ship awake models

Airwake models for DD-963 and DE-1052 class ships have been defined in References 3.9-1 and 3.9-2. These airwake models, or improved versions, shall be used for design and evaluation of the flying qualities of rotorcraft required to takeoff and land on this class ship or to perform other Flight Phases in close proximity to this class ship while under way at sea. The ship airwake environment is specified in Table 3.9-4.

Table 3.9-4
SHIP AIRWAKE AND SHIP MOTION

Environment	Condition*
Operational	7-13
Most Severe	2-6

*The condition numbers refer to Table II of Reference 3.9-1.

DISCUSSION

The air wake behind aviation ships at sea can cause a demanding environment for operation of rotorcraft. Wind tunnel tests of models of the DD-963 and DE-1052 class ships have been performed by Boeing Vertol and ship air wake models have been developed in References 3.9-1 and 3.9-2. These models are defined for combinations of ship speed wind speed, ship direction and wind direction. Table II from Ref. 3.9-1 lists thirteen compatible environmental parameter conditions for combined sea state and wind conditions. The conditions listed in Table II have been divided into two groups and used to define the Operational and the Most Severe Environments for the rotorcraft flying qualities specification. Table II from Ref. 3.9-1 is included here as Figure B-7.

The airwake models defined in Ref. 3.9-1 have been programmed and stored on disk files at NASA Ames for use in ground simulation experiments and considerable experience has been gained in the use of these models for investigation of helicopter and VTOL type aircraft operations near small ships.

Ongoing efforts by the Navy are aimed at extending the data base and techniques for modelling the ship airwake environment and revised airwake models may be available in the future.

TABLE II - SELECTED COMPATIBLE ENVIRONMENTAL PARAMETER CONDITIONS

CONDI- TION	SEA STATE	V _S (kt)	μ _S (deg)	ψ _{WIND} (deg)	ψ _{WOD} (deg)	V _{WIND} (kt)	V _{WOD} (kt)	H _S (ft)	T _O (sec)
1	6	25	120	-60	-30	25.00	43.30	18	15.13
2	5	25	120	-60	-30	25.00	43.30	12	13.50
3	5	20	120	-60	-30	20.00	34.64	12	13.50
4	5	10	135	-45	-30	19.32	27.32	12	13.07
5	5	25	180	0	0	20→24	45→49	12	12.07
6	5	5	180	0	0	20→24	25→29	12	11.51
7	4	25	105	-75	-30	17.68	34.15	6.9	10.6
8	3	25	105	-75	-30	17.68	34.15	4.6	8.8
9	3	20	105	-75	-30	14.14	27.32	4.6	8.8
10	3	25	90	-90	-30	14.43	28.87	4.6	8.8
11	3	15	120	-60	-30	15.00	25.98	4.6	8.8
12	3	25	180	0	0	14→18	39→43	4.6	8.8
13	3	5	180	0	0	14→18	19→23	4.6	8.8

Figure B-7 TABLE II FROM REFERENCE 3.9-1

LIST OF SYMBOLS AND ACRONYMS FOR TABLE II

I. Symbols

Symbols used repeatedly in the text are defined below; symbols used infrequently are defined in the text where used.

H_s	Significant Wave Height (ft)
T_0	Modal Wave Period (sec)
V_s	Ship speed (kt)
V_{WIND}	Ambient Wind Speed (kt or ft/sec)
V_{WOD}	Wind Over Deck Speed (kt or ft/sec)
α_s	Ship Direction with Respect to Predominant Wave Direction (deg)
ψ_{S_0}	Ship Initial Heading with Respect to North (deg)
ψ_{WIND}	Ambient Wind Direction with Respect to Ship Heading (deg)
ψ_{WOD}	Wind Over Deck Direction with Respect to Ship Heading (deg)

3.9.6 Rainfall model

The rainfall rate environment is specified in Table 3.9-5.

Table 3.9-5
RAINFALL RATE ENVIRONMENT

Environment	Rainfall Rate
Operational	50 mm/Hour
Most Severe	83 mm/Hour

DISCUSSION

Rainfall can be a significant environmental factor effecting rotorcraft operations and pilot workload. Rainfall effects the pilot's visual range, canopy transparency, windshield wiper rates and the performance of electro-optical and infra-red sensors. The rainfall models listed in Figure B-8 were collected and presented in Ref. B-5. The rainfall rates identified in Table 3.9-5 for the Operational and Most Severe Environments are based on the rainfall rates listed in Figure B-8 for "Heaviest Mile - 1% worst world wide" and the "Recommended Model Heaviest Mile".

Rain Model	Rain Rate, mm/hr.				
	Heaviest Mile	Next 3 Mi	First 10 Mi Average	10-20 Mi Average	0-20 Mi Average
ETAC General Model	1.72R*	0.76R	0.72R	0.53 R	0.62R
Recommended Model	82.6	36.5	34.6	25.4	29.7
RTCA's SC-117 Landing System Model					
1% worst U.S.	19.8	6.86	7.11		5.08
0.1% worst U.S.	104.6	46.2	40.5		29.9
1% worst worldwide	49.3	20.3	20.0		17.4
0.1% worst worldwide	166.1	73.4	69.1		60.4
AN/TPN-19 Instrument Landing System Model	50	50	50		
Worldwide Extreme Rainfall-Point Rate	1872				

* R = measured ten minute point rainfall
in the locale under consideration

Figure B-8 COMPARISON OF RAIN MODELS

3.9.7 Atmospheric temperature, pressure and density

The variation of air temperature, pressure and density with altitude is specified in Table 3.9-6.

Table 3.9-6

Environment	Atmopshere
Operational	Standard
Most Severe	Army Hot Day

DISCUSSION

Air temperature and density are significant factors influencing the performance of engines and rotor systems. It is, therefore, necessary to specify the characteristics of the atmosphere which must be used in the design and evaluation process. The Standard Day and the Army Hot Day are specified as the Operational and Most Severe Environments. It is not intended that these designations should preclude incorporation of design requirements for specific combinations of atmospheric parameters other than those implied by the designated atmospheric models.

3.9.8 Ambient light

Ambient light conditions are defined as follows.

Day-direct bright sunlight	1×10^4 foot candles
Night-low light level	2.5×10^{-4} foot candles
Dark	No light

DISCUSSION

Ambient light conditions are important to rotorcraft operations because they effect the pilot's capability to see terrain features and obstacles and the ability to read instruments and displays. Both high and low light intensities are of concern. The Day-direct bright sunlight condition of 1×10^4 foot candles is an accepted design standard for readability of electronic displays. The Night-low light level of 2.5×10^{-4} foot candles is taken from Ref. B-10 and represents the conditions used by the Army Owl Team to designate low light level. It corresponds to a moonless night.

3.9.9 Surface slope-takeoff/landing

The surface slope conditions for which the rotorcraft must be designed to perform takeoff and landing operations are specified in Table 3.9-7.

Table 3.9-7
SURFACE SLOPE-TAKEOFF/LANDING

Environment	Slope
Operational	10° All azimuth angles relative to nose
Most Severe	15° Side-to-side

DISCUSSION

Military rotorcraft must have a capability to land and take off from uneven terrain. The surface slope conditions specified in AMC-SS-AAH-H10000A for the advanced attack helicopter were 12 degrees with any aircraft orientation relative to the slope and 15 degrees with the aircraft longitudinal axis oriented 90 degrees (sideways) to the slope. Test data for the AH-64 indicated the 12 degree requirement to be severe for nose up or nose down the slope. The Operational requirement recommended is 10 degrees.

3.9.10 Ship motion models

Ship motion models for the DD 963 class ship are defined in Ref. 3.9-1. These ship motion models, or improved versions, shall be used for design and evaluation of the flying qualities of rotorcraft required to takeoff and land on this class ship. The ship motion environment is specified in Table 3.9-4.

DISCUSSION

The landing deck motions of DD 963 class ships at sea can cause a demanding environment for operation of rotorcraft. Data taken aboard ships in rough seas has been used to develop mathematical models for computing deck motions. See References 3.9-3 - 3.9-5 in Section 3. Table II from Reference 3.9-1 lists thirteen compatible environmental parameter combinations for combined sea state and wind conditions. The conditions listed in Table II have been divided into two groups and used to define the Operational and the Most Severe Environments for the rotorcraft flying qualities specification. Table II from Ref. 3.9-1 is included here as Figure B-7. See also the discussion of paragraph 3.9.5.

3.9.11 Flight deck environment

The flight deck configuration, size, visual landing aids and accessories of aviation facility ships defined in References 3.9-6 and 3.9-1 shall be used for design and evaluation of the flying qualities of rotorcraft required to takeoff and land on or otherwise operate in conjunction with aviation facility ships.

DISCUSSION

The flight deck environment is defined to facilitate design of the rotorcraft and to establish a reference environment for use in evaluation of rotorcraft flying qualities.

REFERENCES FOR APPENDIX B

- B-1 Anon. "Military Specification Flying Qualities of Piloted Airplanes" MIL-F-8785B (ASG), 7 August 1969.
- B-2 Chalk, C.R. et al "Background Information and Users Guide for MIL-F-8785B (ASG) Military Specification-Flying Qualities of Piloted Airplanes" AFFDL-TR-69-72, August 1969.
- B-3 Chalk, C.R. et al "Revisions to MIL-F-8785B (ASG) Proposed by Cornell Aeronautical Laboratory Under Contract F33615-71-C-1254" AFFDL-TR-72-41, April 1973.
- B-4 Anon "Military Specification Flying Qualities of Piloted Airplanes" MIL-F-8785C, Nov. 1980.
- B-5 Moorhouse, D.J.; R.J. Woodcock "Background Information and Users Guide for MIL-F-8785C, Military Specification - Flying Qualities of Piloted Airplanes" AFWAL-TR-81-3109, July 1982.
- B-6 Hoh, R.H., et al "Proposed MIL STANDARD and Handbook - Flying Qualities of Air Vehicles" Vol I. Proposed MIL Standard, Vol. II Proposed MIL Handbook, AFWAL-TR-82-3081, Nov. 1982.
- B-7 Frost, W. "Flight in Low-Level Wind Shear" NASA CR Report 3678. FWG Associates Inc. Tullahoma, Tennessee 1983.
- B-8 Frost, W.; et al. "Simulated Flight Through JAWS Wind Shear" Vol. 21 No. 10, Oct. 1984. Journal of Aircraft.
- B-9 Kawatani, T.; W.Z. Sadeh "An Investigation of Flow Over High Roughness" R&D TR-ECOM-C-0423-10 U.S. Army Electronics Command and Office of Naval Research, Aug. 1971.
- B-10 Park, R.S. (CW2) "NOE At Night-Getting Started" U.S. Army Aviation V. 20 #3 March 1974.

Appendix C
BIBLIOGRAPHY

1. NAVTOLAND Project Office NAVAIR-03PA4: "Expanded Addendum to Program Plan - Schedules and Work Statements", March 1978, P.E. 63203N Project W0570.
2. Chalk, C. R. "Two Combinations of Control Systems and Information Display Systems Recommended for Application to Lift/Cruise Fan VTOL Aircraft", Calspan Corporation FRM No. 532, July 1978.
3. Ringland, R. F. and Clement, W. F.: "Potential Control/Display Configurations for V/STOL Terminal Operations", Vol. I, II, III, November 1978, NADC 77030-30.
4. Lebacqz, J. V.: "Survey of Helicopter Control/Display Investigations for Instrument Decelerating Approach", NASA TM 78565, March 1979.
5. Walters, D. J. and Beyer, R.: "V/STOL Displays for Approach and Landing in Guidance and Control Displays", AGARD CP-96, February 1972.
6. "V/STOL Displays for Approach and Landing", AGARD-R-594, July 1972.
7. Lebacqz, J. V. and Aiken, E. W.: "A Flight Investigation of Control, Display, and Guidance Requirements for Decelerating Descending VTOL Instrument Transitions Using the X-22A Variable Stability Aircraft", Calspan Corporation Report AK-5336-F-1, September 1975.
8. Niessen, F. R.; Kelly, J. R.; Garren, J. F., Jr.; Yenni, K. R.; Person, L. H.: "The Effect of Variations in Controls and Displays on Helicopter Instrument Approach Capability", NASA TND-8385, February 1977.
9. CAE Electronics Ltd.: "Tactical Aircraft Guidance System Advanced Development Program Flight Test Report", Vol. I USAAMRDL-TR-73-89A, April 1974, Vol II USAAMRDL-TR-73-89B, April 1974.
10. Boeing Vertol: "Heavy Lift Helicopter Flight Control System, Vol. II Primary Flight Control System Development and Feasibility Demonstration", USAAMRDL-TR-77-40B, Vol. III "Automatic Flight Control System Development and Feasibility Demonstration", USAAMRDL-TR-77-40C, September 1977.
11. Waugh, J. D. and Stephens, J. A.: "Helicopter Integrated Control (GAT-2H)", Human Engineering Lab., Aberdeen Proving Ground, December 1976, HEL-TM-39-76, AD-A036 204.
12. Thomas, C. L.; Mathews, M. S. and Arnold, J. R.: "Integrated Controller Evaluation", Army Aviation Engineering Flight Activity, September 1976, USAAEFA-75-24, AD-A035-064.
13. Gilson, R. D.; Dunn, R. S. and Sun, P.: "A Kinesthetic-Tactual Display Concept for Helicopter-Pilot Workload Reduction", 33rd Annual National Forum of the American Helicopter Society, May 1977, Preprint No. 77.33-22.
14. Gilson, R. D.; Dunn, R. S. and Sun, P.: "Helicopter Commands at the Touch of a Hand", 35th Annual National Forum of the American Helicopter Society", May 1979, Preprint No. 79-13.
15. Bryant, W. B.; Cattel, J. J.; Russell, W. A. and Trueblood, R. B.: "VTOL Advanced Flight Control System Studies for All-Weather Flight", Vol. I - Task I Final Report, USAAMRDL-TR-75-13A, Charles Stark Draper Laboratory, Inc., July 1975.

16. Bryant, W. B.; Cattel, J. J.; Russell, W. A. and Trueblood, R. B.: "VTOL Advanced Flight Control System Studies for All-Weather Flight", Vol. II - Task III Report, USAAMRDL-TR-75-13A, Charles Stark Draper Laboratory, Inc., July 1975.
17. McGee, L. A.; Schmidt, S. F. and Miyashio, S. K.: "Navigation Performance of the TRISCAN Concept for Shipboard VTOL Aircraft Operations", AIAA Guidance and Control Conference, Palo Alto, California, 1978, AIAA No. 78-1293.
18. Miyashiro, S. E. and Morris, F. E.: "VTOL/Helicopter Approach and Landing Guidance Sensors for Navy Ship Applications", Paper delivered April 1977 at Navy/NASA VSTOL Flying Qualities Workshop, Navy Postgraduate School, Monterey, California.
19. Miller, R. J. and Tribken, E. R.: "An Automatic Flight Control System for a Helicopter Night Landing System", Sperry Flight Systems, Paper published in AGARD-CP-148, May 1974.
20. Collins Avionics: "Collins IFR Technology Program for CH-3E Helicopter VTOL", Technical Report 523-0765447-00111L, April 1974.
21. McElreath, N. W., Capt.; Klein, J. A. and Thomas, R. C.: "V/STOL Aircraft Control/Display Concept for Maximum Operational Effectiveness", AFFDL and Collins Radio, published in AGARD-CP-137, May 1974.
22. Tsoubanos, C. M.: "An Investigation of Displayed Ground-Referenced Position, Velocity and Acceleration for Precision Hover", U.S. Army Electronics Command ECOM-4334, July 1975.
23. Mabli, R. A.: "Final Report on the Development and Evaluation of Flight Control-Display Concepts in the CH-3 Helicopter", Lear Siegler, Inc. Report No. ADR-741/1, 1 July 1971.
24. Garren, J. F., Jr.; Kelly, J. R.; Sommer, R. W. and DiCarlo, D. J.: "Flight Investigation of VTOL Control and Display Concept for Performing Decelerating Approaches to an Instrument Hover", NASA TN D-6108, February 1971.
25. Kelly, J. R.; Niessen, F. R.; Thibodeaux, J. J.; Yenni, K. R. and Garren, J. F., Jr.: "Flight Investigation of Manual and Automatic VTOL Decelerating Instrument Approaches and Landings", NASA TN D-7524, July 1974.
26. Kelly, J. R.; Niessen, F. R. and Garren, J. F., Jr.: "A Manual-Control Approach to Development of VTOL Automatic Landing Technology", paper presented at the 29th Annual National Forum of the American Helicopter Society, Washington, D. C., May 1973, Preprint No. 742.
27. Kelly, J. R.; Niessen, F. R.; Yenni, K. R. and Person, L. H., Jr.: "Flight Investigation of a Vertical-Velocity Command System for VTOL Aircraft", NASA TN D-8480, July 1977.
28. Moen, G. C. and Yenni, K. R.: "Simulation and Flight Studies of an Approach Profile Indicator for VTOL Aircraft", NASA TN D-8051, November 1975.
29. NASA/LRC VALT CH-47 Flight Test Program, (Report in preparation).

30. "Advanced Flight Control System Concepts for VTOL Aircraft (U)", USAAVLABS Technical Report 66-74, May 1967.
31. "Advanced Flight Control System Concepts for VTOL Aircraft (U)", Phase III Technical Report, USAAVLABS Technical Report 69-95.
32. Huff, R. W.; Russell, R. A. and Zalesak, T. W.: "National Microwave Landing System (MLS) Supporting Development", Final Report, NATC Technical Report No. RW-48R-76, 9 December 1976.
33. Momiya, T. S.: "Project NAVTOLAND", paper 1979, Advanced Aircraft Development and Systems Objectives Office, Naval Air Systems Command.
34. Kizer, C. R., Lt.; Kolwey, H. G. and DeProspero, F. J.: "Flight Evaluation of the Hover Augmentation System (HAS) in the RH-3A Helicopter", Naval Air Test Center Report No. FT-1R-69, January 1969.
35. Buffum, R. S. and Tribken, E. R.: "A Path-Damping System for VTOL Aircraft".
36. Picasso, B. D., et al.: "Airworthiness and Flight Characteristics Test Part 2 YAH-64 Advanced Atta.; Army Aviation Engineering Flight Activity, Edwards AFB, CA.; USAAEFA-80-17-2, February 1982.
37. Bender, G. L., Higgins, L. B., Savase, "Airworthiness and Flight Characteristics Test. Part I. YAH-64 A--ETC(U), Army Aviation Engineering Flight Activity, Edwards AFB, CA., USAAEFA-80-17-1, September 1981.
38. Picasso, B. D. et al., "Airworthiness and Flight Characteristics (A&FC) Test of YAH-64 Advanced A..", Army Aviation Engineering Flight Activity, Edwards AFB, CA., USAAEFA-80-17-3, October 1982.
39. Webre, J. L., et al., "Airworthiness and Flight Characteristics (A&FC) of AH-1S with Aircraft", Army Aviation Engineering Flight Activity, Edwards AFB, CA, USAAEFA-82-01, August 1982.
40. Abbott, W. Y., et al., "Validation Flight Test of UH-60A for Rotorcraft Systems Integration Simul., Army Aviation Engineering Flight Activity, Edwards AFB, CA, USAAEFA-79-24, September 1982.
41. Ruddell, A. J., "United Technologies Corp., Stratford, Ct., Sikorsky Aircraft--etc. XH-59A ABC Technology Demonstrator Altitude Expansion and Opera--Etc.", DAAK51-80-C-0021, December 1981.
42. Savage, R. T., et al., "AH-1 Air Ground Engagement Simulation/Air Defense (AGES/ADES) Pod Jettiso.; Army Aviation Engineering Flight Activity, Edwards AFB, CA., USAAEFA-82-06, September 1982.
43. Ward, L. R., "Evaluation of Iroquois UH-1B Stability and Control"; Aircraft Research and Development Unit Edinburgh (Australia), ARDU-TI-783, September 1982.
44. "NASA HAA Advanced Rotorcraft Technology and Tilt Rotor Workshop, Vol. 7; Tilt Rotor Session (NASA), (NASA-TM-847050; 1980, 37 p.

45. Gilbert, N. E., "Aeronautical Research Labs, Melbourne (Australia)"; Data Reduction Procedures for Sea King Helicopter Flight Trials--etc.; ARL/AERO-TM-338; May 1982.
46. "U. S. Army Aviation Digest", v. 20, #3, March 1974.
47. Pausder, H., et al. (NASA); "The Effects of Pilot Stress Factors on Handling Quality Assessments During US German Helicopter Agility Flight Tests"; (NASA-TM-84194), October 1982, 20 p.
48. Landis, K. H. et al., "A Piloted Simulator Investigation of Side-Stick Controller/Stability and . . ."; Boeing Vertol Co., Philadelphia, PA; NAS2-10880; May 1983.
49. Helicopter Handling Qualities (NASA); (NASA CP 2219); April 1982, 243 p.
50. Helicopter Night Vision System Simulation Evaluation, Martin Marietta Aerospace, Orlando, FL; N62269-80-C-0346; December 1981.
51. Corliss, L. D., "A Helicopter Handling-Qualities Study of the Effects of Engine--etc., National Aeronautics and Space Administration Moffett--etc.; April 1982.
52. Tole, J. R. et al., "Quantification of Pilot Workload via Instrument Scan", (Air Force Flight Test Center); (NASA-CR-169238); 21 January 1982, 17 p.
53. Lebacqz, J. V. et al. (NASA); "A Ground Simulator Investigation of Helicopter Longitudinal Flying Qualities for Instrument Approach," (NASA TM 84225); September 1982; 91 p.
54. Lebacqz, J. V. et al. (NASA); "A Piloted Simulator Investigation of Stability and Control Display and Crew Loading Requirements for Helicopter Instrument Approach. Part I Technical Discussion and Results"; (NASA TM-84258-Pt-1); September 1982; 84 p.
55. Lebacqz, J. V. et al. (NASA); "A Piloted Simulator Investigation of Stability and Control Display and Crew-Loading Requirements for Helicopter Instrument Approach. Part 2 Supporting Data"; (NASA-TM-84258-Pt-2); September 1982, 120 p.
56. Lewandowski, F. P. (Singer Co., Sunnyvale, Calif); "VTOL STOL Visual Study Final Report"; (NASA CR 166292); June 1980, 38 p.
57. Parrish, R. V. et al. (NASA); "Comparison of Simulator Fidelity Model Predictions with In-Simulator Evaluation Data"; (NASA TP-2106); Feb. 1983; 39 p.
58. Parrish, R. V. et al. (NASA); "Application of Nonlinear Adaptive Motion Washout to Transport Ground Handling Simulation"; (NASA TM 84508); February 1983, 41 p.
59. "Advanced Aircrew Display Symposium Proceedings (5th) Held at Patuxent Maryland"; Naval Air Test Center, Patuxent River, MD; 15-16 September 1981.
60. McConkey, E. D. et al.; "Instrument Approach Aids for Helicopters"; Systems Control Technology Inc., West Palm Beach, FL; DOT/FAA/RD-82/6; July 1982.

61. "Helicopter Night Vision System Simulation Evaluation", Martin Marietta Aerospace, Orlando, FL; December 1981.
62. Adams, J. J. (NASA); "Flight Test Verification of a Pictorial Display for General Aviation Instrument Approach"; (NASA TM 83305); June 1982; 25 p.
63. Bar-Gill, A. et al. (Princeton Univ., N. J.); "Development of Flying Qualities for Single Pilot Instrument Flight Operations"; Interim Report, Sept.1979 - May 1981; June 1982, 167 p.
64. Richards, W., Dismukes, K.; "National Research Council, Washington, DC Assembly of - etc. Vision Research for Flight Simulation"; F33615-80-C-0009; July 1982.
65. Kopala, C. J., et al.; "Symbology Verification Study;" Bunker-Ramo Corp., Westlake Village of Electronic Systems Division; AFWAL-TR-82-3080; January 1983.
66. Fisher, R. W. (McDonnell Aircraft Co.); "Variable Acuity Remote Viewing System Flight Demonstration"; (NASA-CR-170404; July 1983; 67 p.
67. Phillips, J. D. (NASA); "Mathematical Model of the SH-3G Helicopter"; (NASA-TM-84316); December 1982; 56 p.
68. O'Neill, H. J., "Calculation of the Longitudinal Stability Derivatives and Modes of Motion for Helicopter Aircraft"; Naval Postgraduate School, Monterey, CA; October 1982.
69. Rue, R. J. et al. (Boeing Military Airplane Development); "Conceptual Design Study for an Advanced CAB and VISUAL System. Volume 1 Final Report"; July 1980; 116 p.
70. Rue, R. J. et al. (Boeing Military Airplane Development); "Conceptual Design Study for an Advanced CAB and VISUAL System. Volume 2 Final Report"; (NASA-CRj-166236); July 1980; 171 p.
71. Gajkowski, B. J.; "User's Guide for the Rotorcraft Flight Simulation Computer Prog--etc."; Naval Air Development Center, Warminster, PA Aircraft--etc.; March 1982.
72. Sheridan, P. F. et al.; (Boeing Vertol Co., Philadelphia, PA); "Math Modeling for Helicopter Simulator of Low Speed, Low Altitude and Steeply Descending Flight Final Report", June 1981 - June 1982"; July 1982, 70 p.
73. Hansen, R.S. (NASA); "Toward a Better Understanding of Helicopter Stability Derivatives"; (NASA TM 84277); August 1982, 26 p.
74. Hull, R. (Systems control, Inc., Palo Alto, Calif.); "Development of a Rotorcraft. Propulsion Dynamics Interface Analysis, Volume 1 Final Report"; (NASA-CR-166380); August 1982; 147 p.
75. Hull, R. (Systems Control, Inc., Palo Alto, Calif.); "Development of a Rotorcraft. Propulsion Dynamics Interface Analysis, Volume 2 Final Report"; (NASA-CR-166381); August 1982; 56 p.

76. Talbot, P. D. et al. (NASA); "A Mathematical Model of a Single Main Rotor Helicopter for Piloted Simulation"; (NASA TM 84281); September 1982; 52 p.
77. Key, kD. L. et al. (NASA); "Helicopter Simulation Validation Using Flight Data"; (NASA-TM-84291); November 1982; 16 p.
78. Key, D. L. et al.; " Helicopter Simulation Validation using Flight Data"; National Aeronautics and Space Administration, Moffett Field; CA; Ames Research Center; November 1982.
79. Kobus, D. et al.; "Helicopter Performance Computer Programs"; Naval Air Development Center, Warminster, PA, Aircraft and Crew Systems Technology Directorate; 30 October 1982.
80. Weller, W. H. (Textron Bell Helicopter); "Correlation and Evaluation of Inplane Stability Characteristics for an Advanced Bearingless Main Rotor Final Report"; (NASA-CR-166448); May 1983; 85 p.
81. Thesis, M. S.; Bodson, M. (Massachusetts Inst. of Tech); "Lateral Control System Design for VTOL Landing on a DD963 in High Sea States"; (NASA-CR-169074); May 1982; 22 p.
82. Karmali, et al. (Analytical Mechanics Associates, Inc.); "Sensitivity Analysis of Helicopter IMC Decelerating Steep Approach and Landing Performance to Navigation System Parameters"; (NASA-CR-166412); April 1982; 81 p.
83. Meyer, G. et al. (NASA); "Design of a Helicopte. Autopilot By Means of Linearizing Transformations"; (NASA TM 84295); October 1982; 14 p.
84. Murphy, M. R. et al.; "A Parallel Fly-by-Wire Helicopter Cotnrol System"; Bell Helicopter Textron, Fort Worth, TX; NADC-80132-60, N62269-80-C-0128; March 1982.
85. Hampton, B. J. (Textron Bell Helicopter); "Benefits Assessment of Active Control Technology and Related Cockpit Technology for Rotorcraft"; (NASA-CR-166406); 23 August 1982, 141 p.
86. Goldstein, K.; "A Preliminary Assessment of Helicopter/VSTOL Handling Qualities Specifications"; Naval Air Development Center, Warminster, PA Aircraft and Crew S.; NADC-81023-60; 4 November 1982.
87. Boulet, J. (Snias, Marignane, France); "Point of View of a Helicopter Manufacturer on Airworthiness Regulations"; (SNIAS-821-210-103); 1981; p. 4.
88. Rowley, D. J.; "U.S. Navy Helicopters in Combat Search and Rescue"; Naval Postgraduate School, Monterey, CA; June 1982.
89. Henke, W. P.; "A Statistical Validation Report of Marine Operational V/STOL Environment Simulation (Moves)"; Naval Weapons Engineering Support Activity, Washington, DC; NAVWESA-TM-81-1; June 1981.
90. Magrath, H. A.; "Technical Evaluation Report on the Specialists' Meeting on Dynamic Enviro. "; Advisory Group for Aerospace Research and Development Neuilly.; AGARD-AE-183; July 1982.

91. Markov, A. B. (Toronto Univer. Downsview (Ontario)); "The Landing Approach in Variable Winds Curved Glidepath Geometries and Worst Case Wind Modeling"; (UTIAS 254); December 1981; 376 p.
92. Dunham, R. E., Jr. (NASA); "Low-Altitude Wind Measurements from Wide Body Jet Transports"; (NASA-TM-84538); October 1982; 45 p.
93. Rutkowski, M. J.; "The Vibration Characteristics of a Coupled Helicopter Rotor-Fuselage by A."; National Aeronautics and Space Administration, Moffett Field, CA.; NASA-A-9053 NASA-TP-2118; January 1983.
94. Sopher, R. et al.; "Coupled Rotor/Airframe Vibration Analysis"; United Technologies Corp., Stratford, CT. Sikorsky Aircraft Div.; NASA-CR-3582, NAS1-16058; November 1982.
95. Molusis, J. A. (Molusis (John A.)); "Rotorcraft Blade Mode Damping Identification from Random Responses Using a Recursive Maximum Likelihood Algorithm Final Report"; September 1982; 49 p.
96. Schomer, P. D., Averbuch, A., Raspet, R.; "Construction Engineering Research Lab (Army), Champaign, IL, Operational Noise Data for UH0-60A and CH-47C Army Helicopters"; CERL-TR-N-131; June 1982.
97. Hammond, C. E., et al. (NASA); "An Evaluation of Helicopter Noise and Vibration Ride Qualities Criteria"; (NASA TM 83251); December 1981; 14 p.
98. Weller, W. H. (Textron Bell Helicopter); "Correlating Measured and Predicted Inplane Stability Characteristics for an Advanced Bearingless Rotor Final Report"; (NASA-CR-166280); January 1982; 72 p.
99. Berman, A. "Dynamic System Coupling (DYSCO) Program. Volume II. Theoretical-etc."; Kaman Aerospace Corp., Bloomfield, CT; DAAK 51-79-C-0046; April 1982.
100. Berman, A.; "Dynamic System Coupling (DYSCO) Program. Volume I. User's Manual-etc."; Kaman Aerospace Corp., Bloomfield, CT; DAAK 51-79-C-0046; April 1982.
101. Quackenbush, T. R. (Massachusetts Inst. of Tech.); "Testing and Evaluation of a Stall Flutter Suppression System for Helicopter Rotors Using Individual Blade Control"; (NASA-CR-166233); August 1981; 82 p.
102. Johnson, J. C., Priser, D. B.; "Vibration Levels in Army Helicopter—Measurement and Recommendations—etc."; Army Aeromedical Research Lab, Fort Rucker, AL; USAARL-81-5; September 1981.
103. Hollenbaugh, D. D.; "Quantification of Helicopter Vibration Ride Quality Using Absor—etc."; Army Research and Technology Labs, Fort Eustis, VA Appl.—etc.; AD-A117 290; June 1982.
104. J.F. Needham, Banerjee, D.; "Engine/Airframe/Drive Train Dynamic Interface Documentation, Summa Corp, Culver City, California Hughes Helicopter Div., DAAJ02-77-C-0035, May 1978.
105. Bowes, M. et al. "Engine/Airframe/Drive Train Dynamic Interface Documentation", Kaman Aerospace Corp., Bloomfield, Conn., DAAJ02-77-C-0039, June 1978.

106. Rotorcraft Dynamics (NASA), NASA-SP-352); 1974, 370 p.
107. Richardson, D. A., Alwang, J. R., "Engine/Airframe/Drive Train Dynamic Interface Documentation"; Boeing Vertol Co, Philadelphia, PA, DAAJ02-77-C-0040; April 1978.
108. Hanson, H. W., Balke, R. W., Edwards, B. D., "Engine/Airframe/Drive Train Dynamic Interface Documentation", Bell Helicopter Textron, Fort worth, TX, DAAJ02-77-C-0045, October 1978.
109. Twomey, W. J., Ham, E. H., "Review of Engine/Airframe/Drive Train Dynamic Interface Develop--etc.", United Technologies Corp., Stratford, CT, Sikorsky Aircraft-etc., DAAJ02-77-C-0037; June 1978.
110. Heffley, R. K. et al, (Systems Technology Inc., Mountain View, Calif); "An Analysis of Airline Landing Flare Data Based on Flight and Training Simulator Measurements Final Report, (NASA-CR-166404), August 1992, 117 p.
111. Key, D.L.; "A Critique of Handling Qualities Specifications for U.S. Militia-etc."; Army Research and Technology Labs, Moffett Field, CA; 1980.
112. Turner, E. W., Sims, J. C., White, A. "Categorization fo Atmospheric Turbulence in Terms of Aircraft R--etc."; Air Force Wright Aeronautical Labs Wright-Patterson AFB, OH; November 1981.
113. Campbell, J. B.; "Family of Observation, Scout, and Attack Helicopters, Phase II--Etc."; General Research Corp., McLean, VA Operations Analysis Division; DAHC19-69-C-0017; December 1973.
114. Hamilton, J. W., Bloom, R. F., Bishop, E. W.; "Nap-of-the-Earth FLight: Intra-Cockpit Communications Terms and--Etc."; Dunlap and Associates, Inc., Darien, CT; MDA903-79-C-0586.
115. Bynum, J. A., Holman, G. L.; "Tactical Night Terrain Flight Navigation"; Army Research Inst. for the Behavioral and Social Scie--Etc."; September 1979.
116. Shallcross, G., Rundgren, I. W, Neuwien, R.; "Advanced Scout Helicopter Special Study Group (Ash SSG.) Volume--Etc."; Army Aviation Agency (Center), Fort Rucker, AL.; January 1980.
117. "Advanced Scout Helicopter Special Study Group (Ash SSG). Volume-Etc."; Army Aviation Agency (Center), Fort Rucker, AL; January 1980.
118. Ross, G. A.; "Is a Change in the Tactical Training of Marine Corps Attack Hel--Etc."; Army Command and General Staff, Coll. Fort Leavenworth, Kansas; June 1977.
119. Erdmann, F. et al.; "Equipment for Testing and Measuring a Helmut Mounted Sight and Display" System . . .; (ESA-TT-675)," (ESA, Paris); November 1981, pp. 70.

120. Dasaro, J.A., Elliott, C. T.; "Integration of Controls and Displays in U.S. Army Helicopter Co.--Etc."; Army Aviation Research and Development Command, St. LO--Etc.; USAAVRADCOM-TR-81-E-4; November 1981.
121. "VTOL Advanced Flight Control System studies for all - Volume 2, Task 3", U.S. Army Air Mobility Res. & Dev. Lab., TR-75-13B, July 1975, Final Report.
122. Baumen, W. J.; "Analysis of Delivery Accuracy for AH-1G (COBRA) Launched 2.75-I--Etc."; Army Armament Command, Rock Island, ILL Systems Analys--Etc.; May 1974.
123. Bender, G. L., Arnaiz, H., Ottomeyer, D.; "Preliminary Airworthiness Evaluation AH-1S Helicopter with Ogee--Etc."; Army Aviation Engineering Flight Activity, Edwards AFB, CA; USAAEFA-77-25; May 1980.
124. Wilcock, T. (Rae, Bedford, Engl.); "(ARC-CP-1343) A Piloted Flight Simulation of the Westland Lynx.; 1976; pp. 93.
125. Talbot, P. D. et al. (NASA); "Effects of Rotor Parameter Variations on Handling Qualities of Unaugmented Helicopters in Simulated Terrain Flight"; (NASA TM 81190); August 1980; 88 p.
126. Chen, R.T.N. et al. (NASA); "A Piloted Simulator Study of Augmentation Systems to Improve Helicopter Flying Qualities in Terrain Flight"; (NASA TM 78571); March 1979, 57 p.
127. Parrish, R.V. (NASA); "Preliminary Investigation of Motion Requirements for the Simulation of Helicopter Hover Tasks"; (NASA TM 81801); April 1980; 31 p.
128. Sinclair, S. R., Kereliuk, S.; "Evaluations of Helicopter Instrument-Flight Handling Qualities--Etc.", National Research Council of Canada, Ottawa (Ontario); January 1982.
129. Marshall, A. R., Woratschek, R., Ward, R. N.; "Airworthiness and Flight Characteristics Test of an OH-58C Conf--Etc."; Army Aviation Engineering Flight Activity, Edwards, AFB, CA; October 1981.
130. Staley, J.A.; "Validation of Rotorcraft Flight Simulation Program Through Corr--Etc."; Boeing Vertol Co., Philadelphia, PA; DAJ02-74-C-0051; January 1976.
131. Ricard, G. L., Parrish, R.V., Ashworth, B. R.; "The Effects of Various Fidelity Factors on Simulated Helicopter--Etc."; Naval Training Equipment Center, Orlando, FL;NAVTRAEQUIPC-IH-321; January 1981.
132. Nagata, J.I., Skinner, G.L., Kolwey, S.; "Government Competitive Test Utility Tactical Transport Aircraft--Etc."; Army Aviation Engineering Flight Activity, Edwards AFB, CA.; USAAEFA-74-06-1; November 1976.
133. "Piloted Aircraft Environment Simulation Techniques"; Advisory Group for Aerospace Research and Development--Etc.; April 1978.
134. Statler, I.C., Deel, A.; "The Role Search Simulator in the Systems Development of Rotor--Etc."; Army Aviation Research and Development Command, St. Lo.-Etc.; USAAVRADCOM-TR-81-A-7; 1981.

135. Chen, R.T.N. (NASA), "A Simplified Rotor System Mathematical Model for Piloted Flight Dynamics Simulation"; (NASA TM 78575); May 1979; 28 p.
136. Heffley, R. K. et al. (Systems Technology, Inc., Mountain View, Calif); "A Compilation and Analysis of Helicopter Handling Qualities Data Volume I Data Compilation Report, September 1976, February 1978"; (NASA Cr 3144); August 1979; 387 p.
137. Born, G. J., Carico, D., Durbin, E.J.; "A Dynamic Helicopter Performance and Control Model"; Princeton University, NJ; DA-28-043-AMC-02412; August 1972.
138. Curtiss, H.C. Jr. (Princeton University, NJ); "Sensitivity of Hingeless Rotor Blade Flap Lag Stability in Hover to Analytic Modelling Assumptions"; January 1975, 99 p.
139. Sutton, L. R. (Rochester Applied Science Associates, Inc.); "Development of an Analysis for the Determination of Coupled Helicopter Rotor Control System Dynamic Response. Part 2: Program Listing Final Report"; (NASA-CR-2453); January 1975; 94 p.
140. Hodges, D.H. (NASA); "Aeromechanical Stability of Helicopters with a Bearingless Main Rotor. Part 1: Equations of Motion"; (NASA-TM-78459); February 1978; 102 p.
141. Aiken, E.A.; "A Mathematical Representation of an Advanced Helicopter for PIL-ETC"; National Aeronautics and Space Administration, Moffett-Etc.; July 1980.
142. Warmbrodt, W. (NASA); "Coupled Rotor and Fuselage Equations of Motion"; (NASA TM 81153); October 1979, 82 p.
143. Sturgeon, W.R. et al. NASA; "A Mathematical Model of the CH-53 Helicopter; NASA-TM-81238; November 1980; 60 p.
144. Mackie, D.B. et al. (NASA); "A Real-Time, Dual Processor Simulation of the Rotor System Research Aircraft"; (NASA-TN-D-83280; January 1977; 73 p.
145. Lytwyn, R.T., White, F.; "Ground Based Simulator Input Data for Advanced Tandem-Rotor Hel-Etc."; Boeing Vertol Col, Philadelphia, PA; DAAJ02-72-C-0095; January 1974.
146. Ostroff, A.J. et al. (NASA); "A Technique using a Nonlinear Helicopter Model for Determining Trims and Derivatives"; (NASA TN-D-8159); May 1976; 96 p.
147. Talbot, P.D. et al. (NASA); "A Mathematical Force and Moment Model of a UH-1H Helicopter for Flight Dynamics Simulations"; (NASA-TM-73254); June 1977; 45 p.
148. Aiken, E.A., "A Mathematical Representation of an Advanced Helicopter for Pil-Etc."; National Aeronautics and Space Administration, Moffett-Etc."; NASA-TM-81203; July 1980.
149. Hodge, W.F. (NASA); "Comparison of Analytical and Flight Test Identified Aerodynamic Derivatives for a Tandem Rotor Transport Helicopter"; (NASA TP 1581); February 1980, 56 p.

150. Howe, R.M. (Michigan Univ.); Math Modeling and Computer Mechanization for Real Time Simulation of Rotary Wing Aircraft Final Report, 1 June 1977, 31 March 1979"; (NASA CR-162400); March 1979, 21 p.
151. "NASA HAA Advanced Rotorcraft Technology and Tilt Rotor Workshops, Volume 2 Operators' Views", National Aeronautics and Space Administration); (NASA-TM-84148); 5 December 1980; 111 p.
152. "Advisory Group for Aerospace Research and Development--Etc. Rotorcraft Design"; AGARD-CP-233"; January 1978.
153. "The Impact of Military Applications on Rotorcraft and V/STOL Aircraft--Etc."; Advisory Group for Aerospace Research and Development--Etc.; AGARD-CP-313; June 1981.
154. Hohenemser, K.H. et al. (Washington Univ.); "Computer Experiments in Preparation of System Identification from Transient Rotor Model Tests, Part 2, First Yearly Report"; (NASA-CR-137571); June 1974; 60 p.
155. Brinzinski, S.J. (Sikorsky Aircraft, Stratford, Conn.); "Analytical Investigation of Gust Suppression Techniques for the CH-53 Helicopter Final Report"; (NASA-CR-145013); 1976, 48 p.
156. Johnson, W. (NASA); "Elementary Applications of a Rotorcraft Dynamic Stability Analysis; (NASA-TM-X-73161); June 1976; 24 p.
157. Briczinski, S.J., et al. (United Aircraft Corp.); "Flight Investigation of Rotor Vehicle State Feedback"; (NASA-CR-132546); 1975; 173 p.
158. Reichert, G. et al. (Royal Aircraft Establishment); "Investigations for an Active Vibration Isolation System for Helicopters"; (RAE Lib. Trans. 1993); November 1979; 58 p.
159. Warmbrodt, W. (NASA); "Coupled Rotor and Fuselage Equations of Motion; (NASA TM-81153); October 1979; 82 p.
160. Cunningham, T.B. et al. Honeywell Systems and Research; "Helicopter High Gain Control Final Report"; NASA CR-159052; July 1979; 171 p.
161. Anderson, W.D., Conner, F., Kerr, A.W.; "Application of an Interdisciplinary Rotary-Wing Aircraft Analysis--Etc.; Lockheed-California Co., Burbank; DAAJ02-72-C-0100; December 1973.
162. Staley, J.A.; "Validation of Rotorcraft Flight Simulation Program Through Correlation--Etc."; Boeing Vertol Co., Philadelphia, PA; DAAJ02-74-C-0051; January 1976.
163. Briczinski, S.J.; "Validation of the Rotorcraft Flight Simulation Program (C81) FO--Etc."; United Technologies Corp., Stratford, Conn. Sikorsky Aircraft--Etc.; DAAJ02-74-C-0046; May 1976.

164. Hansen, R.S. (NASA); "On Approximating Higher-Order Rotor Dynamics in Helicopter Stability-Derivative Models"; AIAA-83-2088; August 15-17, 1983.
165. Hansen, R.S. (NASA); "Toward a Better Understanding of Helicopter Stability Derivatives"; U.S. Army Aeromechanics Laboratory, Moffett Field, Calif. 94035; August 31-September 3, 1982.
166. Tomlinson, B.N., Padfield, G.D., Royal Aircraft Establishment, Bedford, England; "Piloted Simulation Studies of Helicopter Agility"; A81-10767.
167. Landis, Kenneth H., Aiken, Edwin W.; "An Assessment of Various Side-Stick Controller/Stability and Control Augmentation Systems for Night Nap-of-the-Earth Flight Using Piloted Simulation"; NASA CP-2214; April 1982.
168. Landis, K.H., Dunford, P.J.; Aiken, E.W.; Hilbert, K.B.; "A Piloted Simulator Investigation of Side-Stick Controller/Stability and Control Augmentation System Requirements for Helicopter Visual Flight Tasks"; May 1983.
169. Aiken, Edwin W. (NASA); "Simulator Investigations of Various Side-Stick Controller/Stability and Control Augmentation Systems for Helicopter Terrain Flight"; 82-1522.
170. Schrage, Daniel P. Capt., Peskar, Robert E.; "Helicopter Vibration Requirements"; Presented at the 33rd Annual National Forum of the American Helicopter Society, Washington, D.C.; May 1977.
171. Schrage, Daniel P., Wolfe, Robert A.; "Dynamics Requirements for an Advanced Scout Helicopter (ASH)"; Presented at the 35th Annual National Forum of the American Helicopter Society, Washington, DC; May 1979.
172. White, F., Blake, B.B.; "Improved Method of Predicting Helicopter Control Response and Gust Sensitivity"; Presented at the 35th Annual National Forum of the American Helicopter Society, Washington, DC; May 1979.
173. Szustak, L.S., Jenney, D.S. (Sikorsky Aircraft); "Control of Large Crane Helicopters"; Presented at the 26th Annual National Forum of the American Helicopter Society, Washington, DC, June 1970.
174. Pausder, Heinz-Jurgen, Hummes, Dieter; "Flight Tests for the Assessment of Task Performance and Control Activity".
175. Pausder, Heinz-Jurgen, Gmelin, Bernd L., "Flight Test Results for Task Oriented Flying Qualities Evaluation"; Presented at the 36th Annual Forum of the American Helicopter Society, Washington, DC, May 1980.
176. White, R.G. (Royal Aircraft Establishment); "Automatic Speech Recognition as a Cockpit Interface".
177. Dukes, T.A. (Princeton Univer.), Keane, W.P., Tsubanos, C.M. (Avionics Laboratory); "Image and Superimposed Symbolology - An Integrated Display for Helicopters"; Presented at the 29th Annual National Forum of the American Helicopter Society, Washington, DC; May 1973.
178. Tsubanos, C.M. (US Army Avionics Research and Development Activity), Kelley, M.B. (US Army Night Vision and Electro-Optical Lab.); Presented at the 34th Annual National Forum of the American Helicopter Society, Washington, DC, May 1978.

179. Harper, H.P., Sardanowsky, Scharpf, R. (Sikorsky Aircraft); "Development of VTOL Flying and Handling Qualities Requirements Using the Mission Task Performance Oriented Approach"; 25th Annual National Forum Proceedings, Sheraton-Park Hotel, Washington, DC, May 14,15,16, 1969.
180. Morris, J.J., Alexander, H.R. (Boeing Vertol Co.); "Definition and Analytical Evaluation of a Power Management System for Tilt-Rotor Aircraft"; Presented at the 34th Annual National Forum of the American Helicopter Society, May 1978; NAS2-6505 and NAS2-6598.
181. Warwick, T.R. (United Aircraft Corp.); "Helicopter Engine Dynamic Analysis"; 25th Annual National Forum Proceedings, Sheraton-Park Hotel, Washington, DC, May 14,15,16, 1969.
182. Kuczynski, W.A., Twomey, W.J., Howlett, J.J. (United Technologies Corp.); "The Influence of Engine/Fuel Control Design on Helicopter Dynamics and Handling Qualities"; Presented at the 35th Annual National Forum of the American Helicopter Society, Washington, DC, May 1979.
183. Fredrickson, C., Rumford, K., Stephenson, C.; "Factors Affecting Fuel Control Stability of a Turbine Engine/Helicopter Rotor Drive System"; Presented at the 27th Annual Forum of the American Helicopter Society, Washington, DC, May 1974.
184. Corless, L.D., Blanken, C.L., Nelson, K. (NASA); "Effects of Rotor Inertia and RPM Control on Helicopter Handling Qualities"; AIAA-83-2070; August 15-17, 1983.
185. Corliss, L.D. (NASA); "A Helicopter Handling-Qualities Study of the Effects of Engine Response Characteristics, Height-Control Dynamics, and Excess Power on Nap-of-the-Earth Operations".
186. Tischler, M.B., Hoh, R.H. (Systems Technology, Inc.); "Handling Qualities Criterion for Flight Path Control of V/STOL Aircraft"; AIAA-82-1292; August 9-11, 1982.
187. Chen, R.T.N. (NASA); "Selection of Some Rotor Parameters to Reduce Pitch-Roll Coupling of Helicopter Flight Dynamics"; American Helicopter Society Mideast Region, National Specialists' Meeting "Rotor System Design", Holiday Inn, 22,23,24 October 1980; Philadelphia, Pa. 19105.
188. Corliss, L.D., Carico, G. D. (NASA); "A Preliminary Flight Investigation of Cross-Coupling and Lateral Damping for Nap-of-the-Earth Helicopter Operations".
189. Chen, R.T.N., Talbot, P.D. (USAAMRDL, Ames Directorate); "An Exploratory Investigation of the Effects of Large Variations in Rotor System Dynamics Design Parameters on Helicopter Handling Characteristics in Nap-of-the-Earth Flight; Presented at the 33rd Annual National Forum of the American Helicopter Society, Washington, DC, May 1977.
190. Onstott, E.; W.H. Faulkner "Definition and Interpretation of Flying Qualities" Mar. 1979. Northrop Report.

1. Report No. CR - 177371 USAAVSCOM TR-85-A-7		2. Government Accession No.		3. Recipient's Catalog No.	
4. Title and Subtitle Mission-Oriented Requirements for Updating MIL-H-8501, Calspan Proposed Structure and Rationale				5. Report Date September 1985	
7. Author(s) Charles R. Chalk and Robert C. Radford				6. Performing Organization Code	
9. Performing Organization Name and Address ARVIN/CALSPAN Advanced Technology Center P. O. Box 400 Buffalo, New York 14225				8. Performing Organization Report No. Calspan Report 7097-F-1	
12. Sponsoring Agency Name and Address U.S. ARMY AEROFLIGHTDYNAMICS DIRECTORATE NASA Ames Research Center Moffett Field, California 94035-1099				10. Work Unit No.	
15. Supplementary Notes POINT OF CONTACT: DAVID L. KEY, Aeroflightdynamics Directorate, M.S. 210-7 Moffett Field, CA 94035-1099 (415) 694-5839 FTS 464-5839				11. Contract or Grant No. NAS2-11303	
16. Abstract <p>This report documents the effort by Arvin/Calspan Corporation to formulate a revision of MIL-H-8501A in terms of Mission-Oriented Flying Qualities Requirements for Military Rotorcraft. Emphasis is placed on development of a specification structure which will permit addressing Operational Missions and Flight Phases, Flight Regions, Classification of Required Operational Capability, Categorization of Flight Phases, and Levels of Flying Qualities. A number of definitions are established to permit addressing the rotorcraft state, flight envelopes, environments, and the conditions under which degraded flying qualities are permitted. Tentative requirements are drafted for Required Operational Capability Class I. Also included is a Background Information and Users Guide for the draft specification structure proposed for the MIL-H-8501A revision. The report also contains a discussion of critical data gaps and attempts to prioritize these data gaps and to suggest experiments that should be performed to generate data needed to support formulation of quantitative design criteria for the additional Operational capability Classes II, III, and IV.</p>				13. Type of Report and Period Covered Phase I Final Report	
17. Key Words (Suggested by Author(s)) Helicopter Design Criteria Rotorcraft Stability and Control MIL-H-8501A Flying Qualities Military Specification				14. Sponsoring Agency Code 1L162209AH76A	
18. Distribution Statement UNLIMITED SUBJECT CATEGORY 08					
19. Security Classif. (of this report) UNCLASSIFIED		20. Security Classif. (of this page) UNCLASSIFIED		21. No. of Pages 285	
				22. Price*	