

**NASA
Technical
Paper
2513**

October 1985

Surface Fatigue Life and
Failure Characteristics
of EX-53, CBS 1000M, and
AISI 9310 Gear Materials

Dennis P. Townsend

NASA



**NASA
Technical
Paper
2513**

1985

Surface Fatigue Life and
Failure Characteristics
of EX-53, CBS 1000M, and
AISI 9310 Gear Materials

Dennis P. Townsend

*Lewis Research Center
Cleveland, Ohio*



National Aeronautics
and Space Administration

Scientific and Technical
Information Branch

Summary

Spur gear endurance tests and rolling-element surface fatigue tests were conducted to investigate EX-53 and CBS 1000M steels for use as advanced application gear materials, to determine their endurance characteristics, and to compare the results with the standard AISI 9310 gear material. The gear pitch diameter was 8.89 cm (3.5 in). Test conditions were an oil inlet temperature of 320 K (116 °F), an oil outlet temperature of 350 K (170 °F), a maximum Hertz stress of 1.71 GPa (248 ksi), and a speed of 10 000 rpm. Bench-type rolling-element fatigue tests were conducted at ambient temperature with a bar specimen speed of 12 500 rpm and a maximum Hertz stress of 4.83 GPa (700 ksi).

The EX-53 test gears had a gear surface fatigue life of twice that of the AISI 9310 spur gears. The CBS 1000M test gears had a surface fatigue life of more than twice that of the AISI 9310 spur gears. However, the CBS 1000M gears experienced a 30-percent tooth fracture failure which limits its use as a gear material. The rolling-contact fatigue lives of RC bar specimens of EX-53 and AISI 9310 were approximately equal. However, the CBS 1000M RC specimens had a surface fatigue life about 50 percent of that of the EX-53 and AISI 9310.

Introduction

In recent years several steels have been developed for gear and bearing applications that have improved strength and improved hot hardness capabilities (refs. 1 and 2). Along with the materials development there has been an increasing demand by aircraft manufacturers and others for gear and bearing steels that will give improved life at normal operating temperatures and allow operation of geared systems and jet engines at higher operating temperatures. With improved hot hardness in a gear material, the gears can operate at higher loads with less scoring and can operate at higher temperatures without reduction in surface fatigue life or spalling failures.

It is normally considered that a bearing or gear material must have a hardness of at least 58 Rockwell C to have a good surface fatigue life. The standard gear material AISI 9310 now used in the aircraft industry

begins to lose its hardness above 394 K (250 °F) (refs. 3 and 4). Therefore, a better hot hardness material is necessary for operation above this temperature. A good gear material should have a hard case for resistance to surface fatigue and a tough core for resistance to bending fatigue and impact loading. For this reason, most gear steels are case hardened and have a medium hard core for improved fracture toughness and resistance to bending failures.

Two recently developed carburizing grade steels that have shown good possibilities for gears and bearings are the EX-53 and the CBS 1000M (refs. 3 and 4). The EX-53 steel has good hot hardness to 505 K (450 °F) and has good fracture toughness (ref. 4). The CBS 1000M has good hot hardness to 589 K (600 °F) and medium fracture toughness (refs. 3 to 5). Because of this good hot hardness plus good machinability and ease of carburizing, the EX-53 and CBS 1000M show promise for use as gear materials in advanced aircraft applications such as turbo-prop and helicopter main-drive gearboxes.

The objectives of the research reported herein were (1) to investigate EX-53 and CBS 1000M for use as gear materials, (2) to determine the surface endurance characteristics of EX-53 and CBS 1000M, and (3) to compare the results with the standard AISI 9310 gear material. To accomplish these objectives, tests were conducted with one lot each of spur gears made from a single heat each of EX-53 and CBS 1000M. For comparison purposes, one lot of spur gears manufactured from a single heat of AISI 9310 was also tested. The gear pitch diameter was 8.89 cm (3.50 in). Test conditions included an oil inlet temperature of 320 K (116 °F) that resulted in an oil outlet temperature of 350 K (170 °F), a maximum Hertz stress of 1.71 GPa (248 ksi), and a shaft speed of 10 000 rpm. Also, bench-type rolling-element fatigue tests were conducted with one lot each of EX-53 and AISI 9310 and three lots of CBS 1000M test bars (ref. 6). These tests were run at ambient temperatures with a bar specimen speed of 12 500 rpm and a maximum Hertz stress of 4.38 GPa (700 ksi).

The RC bar rolling-element fatigue tests were conducted as a quick and inexpensive method of generating rolling-contact (RC) surface fatigue data which could be compared to the gear surface fatigue data for possible correlation. The surface fatigue test results are plotted on Weibull graphs for comparison of the 10-

and 50-percent life of the gears or RC bars. A test was considered complete when a fatigue spall occurs which was equal to or greater than one-half the width of the running surface.

Apparatus and Procedures

Gear Test Apparatus

The gear fatigue tests were performed in the NASA Lewis Research Center's gear fatigue test apparatus (fig.

1). This test rig uses the four-square principle of applying the test gear load so that the input drive only needs to overcome the frictional losses in the system.

A schematic of the test rig is shown in figure 1(b). Oil pressure and leakage flow are supplied to the load vanes through a shaft seal. As the oil pressure is increased on the load vanes inside the slave gear, torque is applied to the shaft. This torque is transmitted through the test gears back to the slave gear where an equal but opposite torque is maintained by the oil pressure. This torque on the test gears, which depends on the hydraulic pressure

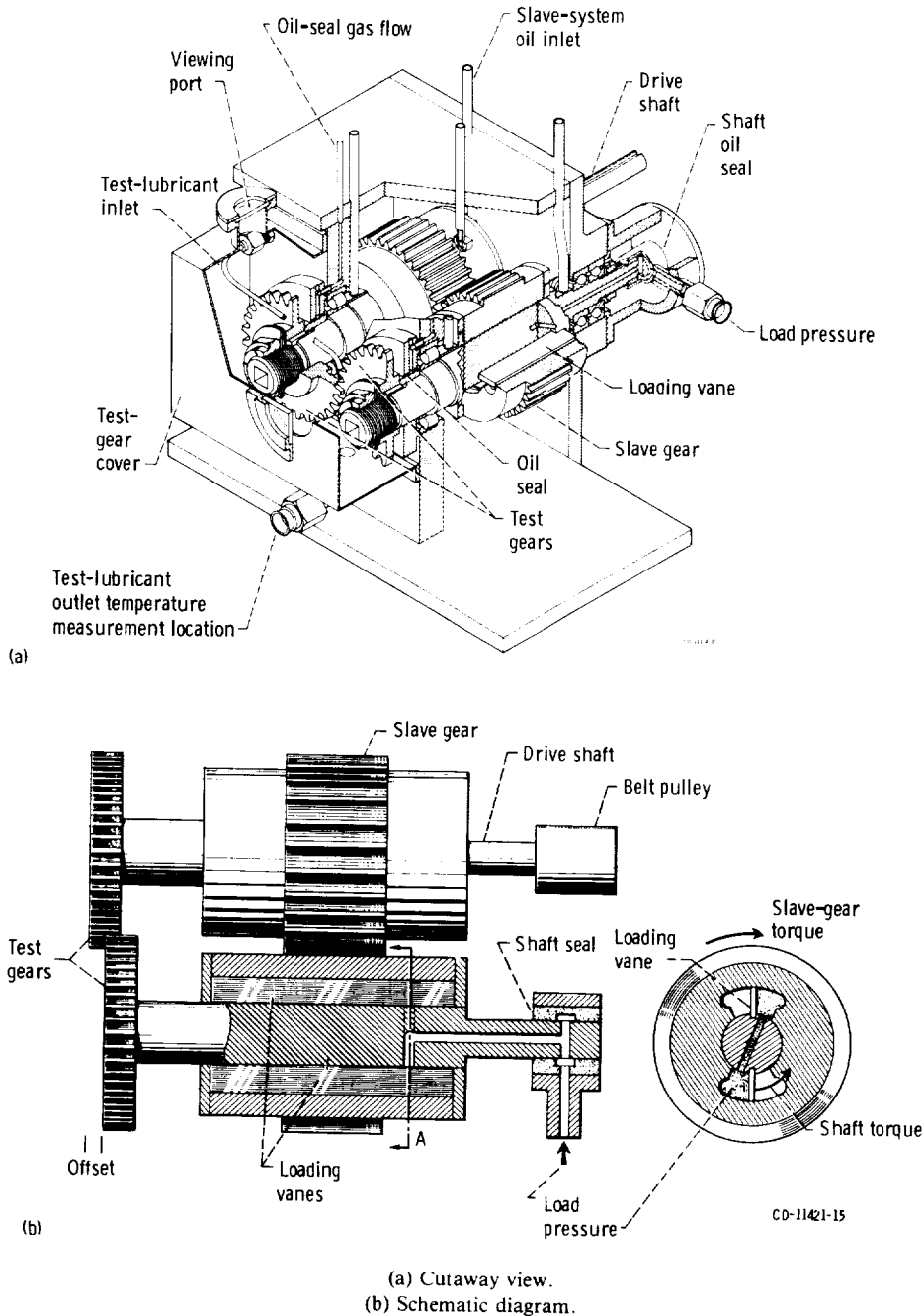

Figure 1.—NASA Lewis Research Center's gear fatigue test apparatus.

applied to the load vanes, loads the gear teeth to the desired stress level. The two identical test gears can be started under no load, and the load can be applied gradually without changing the running track on the gear teeth.

Separate lubrication systems are provided for the test gears and the main gearbox. The two lubricant systems are separated at the gearbox shafts by pressurized labyrinth seals. Nitrogen is the seal gas. The test gear lubricant is filtered through a 5- μm nominal fiberglass filter. The test lubricant can be heated electrically with an immersion heater. The skin temperature of the heater is controlled to prevent overheating the test lubricant.

A vibration transducer mounted on the gearbox is used to automatically shut off the test rig when a gear surface fatigue occurs. The gearbox is also automatically shut off if there is a loss of oil flow to either the main gearbox or the test gears, if the test gear oil overheats, or if there is a loss of seal gas pressurization.

The belt-driven test rig can be operated at several fixed speeds by changing pulleys. The operating speed for the tests reported herein was 10 000 rpm.

Rolling-Contact (RC) Fatigue Tester

The rolling-contact (RC) fatigue tester is shown in figure 2. A cylindrical test bar is mounted in the precision chuck. The drive motor attached to the chuck drives the

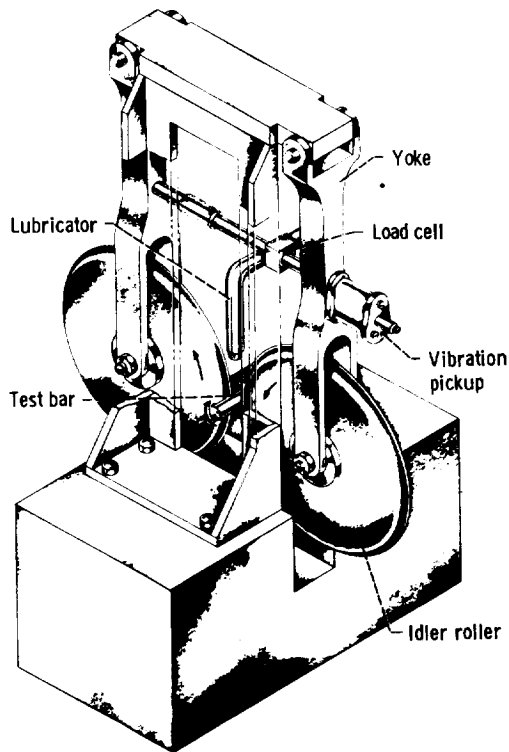

CD-8840

Figure 2.—Rolling-contact fatigue tester.

bar which in turn drives two idler disks. Load is applied by closing the disks against the test bar using a micrometer-threaded turnbuckle and a calibrated load cell. Lubrication is supplied by a drop feed system using a needle valve to control the flow rate. Several test runs can be made on one test bar by moving the bar position in the axial direction relative to disk contacts. The test bar is rotated at 12 500 rpm and receives 25 000 stress cycles per minute. The maximum Hertz stress was 4.83 GPa (700 ksi).

Test Gears

A photograph of the test gears is shown in figure 3. The dimensions of the gears are given in table I. All gears have a nominal surface finish on the tooth face of 0.41 μm (16 μin) rms. All the gears have a standard 20° involute profile with tip relief. The tip relief was 0.0013 cm (0.0005 in) starting at the highest point of single tooth contact.

Rolling-Contact (RC) Test Bar Specimens

The test specimens for the RC fatigue tester were cylindrical bars 7.6 cm (3.0 in) long with a 0.952-cm (0.375-in) diameter. The surface finish was 0.13 to 0.2 μm (5 to 8 μin) rms.

The large mating disks had a diameter of 19 cm (7.5 in) and a crown radius of 0.635 cm (0.250 in). The surface finish of the disks was the same as the test bars.

Test Materials

AISI 9310 baseline gears and RC bars were manufactured from consumable-electrode vacuum-melted (CVM) or vacuum-arc-remelted (VAR) AISI 9310.

The CBS 1000M test gears and RC bars were manufactured from three lots of VAR CBS 1000M. The nominal chemical composition of the material for the gears and bars is given in table II. The heat treatment for the gears and bars material is given in table III. The case and core properties of the materials are given in table IV.

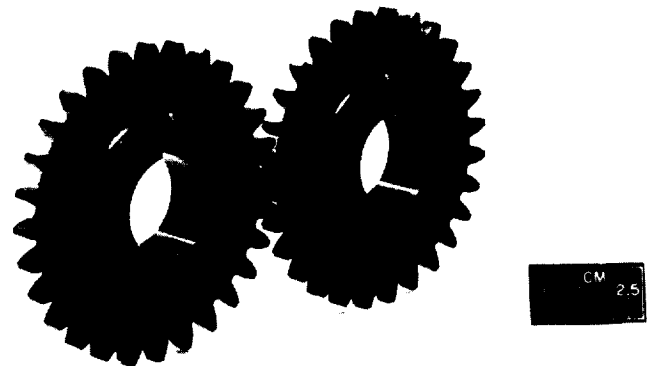

Figure 3.—Test-gear configuration.

TABLE I.—GEAR DATA

[Gear tolerance per AGMA class 12.]

Number of teeth.....	28
Diametral pitch.....	8
Circular pitch, cm (in).....	0.9975 (0.3927)
Whole depth, cm (in).....	0.762 (0.300)
Addendum, cm (in).....	0.318 (0.125)
Chordal tooth thickness reference, cm (in).....	0.485 (0.191)
Pressure angle, deg.....	20
Pitch diameter, cm (in).....	8.890 (3.500)
Outside diameter, cm (in).....	9.525 (3.750)
Root fillet, cm (in).....	0.10 to 0.15 (0.04 to 0.06)
Measurement over pins, cm (in).....	9.603 to 9.630 (3.7807 to 3.7915)
Pin diameter, cm (in).....	0.549 (0.216)
Backlash reference, cm (in).....	0.025 (0.010)
Tip relief, cm (in).....	0.0013 (0.0005)
Tooth width, cm (in).....	0.64 (0.25)

TABLE II.—CHEMICAL COMPOSITION OF TEST MATERIALS BY PERCENT WEIGHT

Element	AISI 9310 RC bars	AISI 9310 gears	EX-53 gears and bars	CBS 1000M		
				Gears	Bars	
					A and B	C
Carbon (core)	0.11	0.11	0.10	0.14	0.135	0.14
Manganese	.69	.58	.37	.48	.48	.48
Phosphorus	.005	.003	.009	.018	.018	.018
Sulfur	.002	.004	.006	.019	.019	.019
Silicon	.30	.26	.98	.43	.43	.43
Copper	.07	.21	2.07	-----	.15	-----
Chromium	1.24	1.38	1.05	1.12	1.12	1.12
Molybdenum	.11	.13	3.30	4.77	4.77	4.77
Vanadium	-----	-----	.12	.1	.33	-----
Nickel	3.19	3.2	2.13	2.94	2.94	2.94
Iron	Balance	Balance	Balance	Balance	Balance	Balance

TABLE III.—HEAT TREATMENT PROCEDURE FOR MATERIAL TESTED

Step	Process	AISI 9310	EX-53	CBS 1000M			
				Gears	Bars		
					A	B	C
1	Preheat	-----	870 K (1100 °F)	1228 K (1750 °F) in air for 0.5 hr	1228 K (1750 °F) in air for 1 hr	1241 K (1775 °F) in vacuum for 1 hr	866 K (1100 °F) in air for 2 hr
2	Carburize	1172 K (1650 °F) for 8 hr	1172 K (1650 °F) for 5 hr	1228 K (1750 °F) for 8 hr	1227 K (1750 °F) for 11 hr	1214 K (1725 °F) for 10 hr	1200 K (1700 °F) for 2 hr
3	Temper	922 K (1200 °F) for 10 hr	894 K (1150 °F) for 2 hr	755 K (900 °F) for 1.5 hr	-----	1089 K (1500 °F)	1089 K (1500 °F) in vacuum for 0.25 hr
4	Austenize or harden	1088 K (1500 °F) for 2.5 hr	1180 K (1675 °F) for 0.5 hr	Preheat at 1090 K (1500 °F) then equalize at 1366 K (2000 °F) for 10 min	1366 K (2000 °F)	1366 K (2000 °F)	1380 K (2025 °F)
5	Temper	-----	-----	644 K (700 °F) for 1 hr	-----	644 K (700 °F) for 1 hr	-----
6	Deep freeze	190 K (-120 °F) for 3.5 hr	200 K (-100 °F) for 1 hr	200 K (-100 °F) for 1 hr	-----	200 K (-100 °F) for 1 hr	200 K (-100 °F) for 1 hr
7	Temper	450 K (350 °F) for 2 hr	505 K (450 °F) for 2+2+2 hr	811 K (1000 °F) for 2+2+2 hr	811 K (1000 °F) for 2+2+2 hr	811 K (1000 °F) for 2+2+2 hr	811 K (1000 °F) for 2+2+2 hr

TABLE IV.—CASE AND CORE CHARACTERISTICS

Material	Effective case depth to RC 5, mm (in)	Case hardness, RC	Core hardness, RC	Case retained austenite, percent
EX-53 gears and bars	1.02 (0.040)	61	40	21
9310 gears	.81 (.032)	61	38	10
Bars	.84 (.033)	61.4	38	11.2
CBS 1000M gears	1.52 (.060)	62	51	—
Bars A	1.09 (.043)	61.6	47	1.7
Bars B	.76 (.030)	60.9	47	.4
Bars C	.76 (.030)	60.5	41	0

Photomicrographs of the case and core of the gear and RC bar materials are shown in figures 4(a) to (c).

The EX-53 test gears and RC test bars were manufactured from a single heat of vacuum-induction-melted, vacuum-arc-remelted (VIM-VAR) EX-53.

Lubricant

All the gears were lubricated with a single batch of synthetic paraffinic oil, which was the standard test lubricant for the gear tests. The physical properties of this lubricant are summarized in table V. Five percent of an extreme pressure additive, designated Lubrizol 5002 (partial chemical analysis given in table V) was added to the lubricant.

The RC test specimens were lubricated with a standard diester-type test lubricant, meeting the MIL-L-7808 specification. The fluid comprised a mixture of two base stocks, a diester plus a (trimethylol propane) polyester. The additives in this fluid included antioxidants, load-carrying additives, metal passivators, a hydrolytic stability additive, and a silicone antifoam additive. The

TABLE V.—LUBRICANT PROPERTIES

Property	Synthetic paraffinic oil plus additives ^b	Diester plus TMP ^a polyester plus additives ^c
Kinematic viscosity, cm ² /sec (cs) at:		
244 K (-20 °F)	2500 × 10 ⁻² (2500)	580 × 10 ⁻² (580)
311 K (100 °F)	31.6 × 10 ⁻² (31.6)	14.8 × 10 ⁻² (14.8)
372 K (210 °F)	5.5 × 10 ⁻² (5.5)	3.7 × 10 ⁻² (3.7)
477 K (400 °F)	2.0 × 10 ⁻² (2.0)	1.2 × 10 ⁻² (1.2)
Flash point, K (°F)	508 (455)	491 (425)
Fire point, K (°F)	533 (500)	527 (490)
Pour point, K (°F)	219 (-65)	213 (-75)
Specific gravity	0.8285	0.950
Vapor pressure at 311 K (100 °F), mm Hg (or torr)	0.1	10 ⁻⁵
Specific heat at 311 K (100 °F), J/(kg)(K)(Btu/(lb)(°F))	2190 (0.523)	1968 (0.470)

^a Trimethylol propane.

^b Additive, Lubrizol 5002 (5 vol %), phosphorus, 0.03 vol %, sulfur, 0.93 vol %.

^c Additive content is proprietary to the manufacturer.

types and levels of the additives are proprietary. The lubricant properties are given in table V.

Test Procedure

Gears.—After the test gears were cleaned to remove their protective coating, they were assembled on the test rig. The test gears ran in an offset condition with a 0.30-cm (0.120-in) tooth-surface overlap to give a load surface on the gear face of 0.28 cm (0.110 in), thereby allowing for an edge radius of gear teeth. If both faces of the gears were tested, four fatigue tests could be run for each set of gears. All tests were run-in at a load per unit length of 1230 N/cm (700 lb/in) for 1 hr. The load was then increased to 5800 N/cm (3300 lb/in), which resulted in a 1.71-GPa (248-ksi) pitch-line maximum Hertz stress.

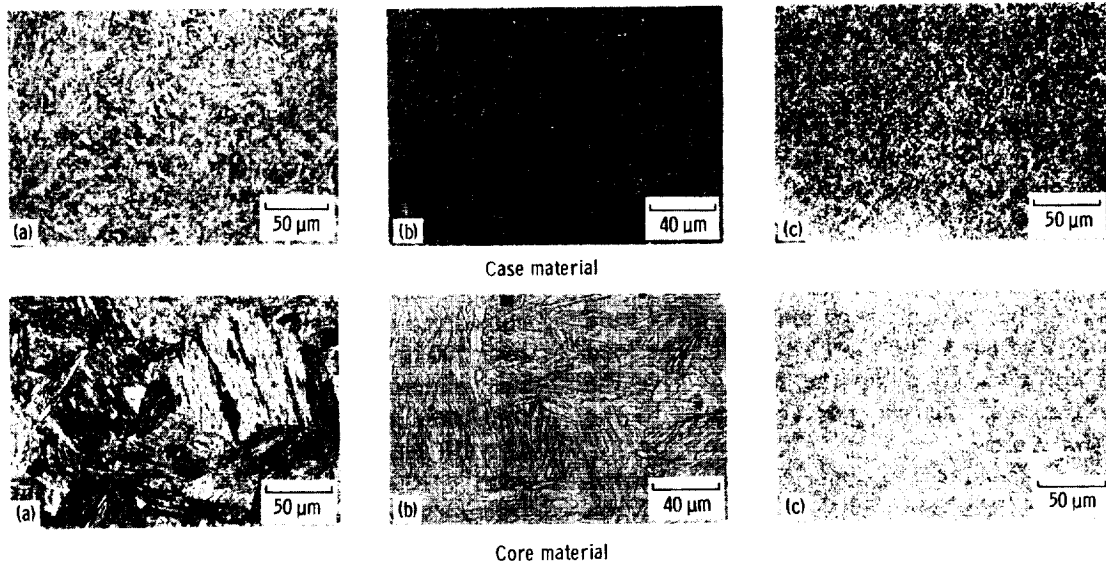

- (a) Optical microstructure of AISI 9310, Nital Etch.
 (b) Optical microstructure of CBS 1000M, Nital Etch.
 (c) Optical microstructure of EX-53, Nital Etch.

Figure 4.—Photomicrographs of the case and core material for the test gears and RC bars.

At the pitchline load the tooth bending stress was 0.21 GPa (30 ksi) if plain bending was assumed. However, because there was an offset load, there was an additional stress imposed on the tooth bending stress. Combining the bending and torsional moments gave a maximum stress of 0.26 GPa (37 ksi). This bending stress did not include the effects of tip relief which would also increase the bending stress.

Operating the test gears at 10 000 rpm gave a pitchline velocity of 46.55 m/sec (9163 ft/min). Lubricant was supplied to the inlet mesh at 800 cm³/min (49 in³/min) and 320 ± 6 K (116 ± 10 °F). The lubricant outlet temperature was nearly constant at 350 ± 3 K (170 ± 5 °F). The tests ran continuously (24 hr/day) until the rig was automatically shut down by the vibration detection transducer (located on the gearbox adjacent to the test gears) or until 500 hr of operation without failure were completed. The lubricant circulated through a 5-μm fiberglass filter to remove wear particles. For each test, 3.8 liters (1 gal) of lubricant were used. At the end of each test, the lubricant and filter element were discarded. Inlet and outlet oil temperatures were continuously recorded on a strip-chart recorder.

The pitchline elastohydrodynamic (EHD) film thickness was calculated by the method of reference 7. It was assumed, for this film thickness calculation, that the gear temperature at the pitchline was equal to the outlet oil temperature and that the inlet oil temperature to the contact zone was equal to the gear temperature, even though the oil inlet temperature was considerably lower. It is possible that the gear surface temperature was even higher than the oil temperature, especially at the end points of sliding contact. The EHD film thickness for these conditions was computed to be 0.33 μm (13 μin), which gave an initial ratio of film thickness to composite surface roughness (h/σ) of 0.55 at the 1.71-GPa (248-ksi) pitchline maximum Hertz stress.

Each pair of gears was considered as a system and, hence, a single test. Test results were evaluated using Weibull plots calculated by the method of Johnson (ref. 8). (A Weibull plot is the number of stress cycles versus the statistical percent of gear systems failed.)

RC tests.—Fatigue testing was also performed in the RC rig. The test bar was installed and the disks were brought against the bar using the turnbuckle. The load applied was sufficient to allow the bar to drive the contacting disks, and the bar was accelerated to the 12 500 rpm test speed.

When the disks and test bar were in thermal equilibrium at a bar temperature of ~305 K (90 °F), the full load of 1250 N (281 lb) was applied to give the test bar a maximum Hertz stress of 4.83 GPa (700 ksi). When a fatigue failure occurred, the rig and related instrumentation were automatically shut down by a vibration detection system. The axial position of the test

bar in the drive chuck was changed to use a new running track before testing was resumed. Test results were also evaluated according to the methods of reference 8.

Results and Discussion

Gear Life Results

One lot each of VAR CBS 1000M, VIM-VAR EX-53, and CVM AISI 9310 spur gears was endurance tested. Test conditions were a tangential tooth load of 5800 N/cm (3300 lb/in), which produced a maximum Hertz stress of 1.71 GPa (248 ksi), and a speed of 10 000 rpm. The gears failed either by classical subsurface pitting fatigue or tooth bending fracture. The pitting fatigue life results of these tests are shown in the Weibull plots of figure 5 and are summarized in table VI.

Pitting fatigue life results for the gears made from the CVM AISI 9310 material are shown in figure 5(a). The 10- and 50-percent lives were 18.8×10^6 and 46×10^6 stress cycles (31 and 77 hr), respectively. The failure index (i.e., the number of fatigue failures out of the number of sets tested) was 18 out of 19. A typical fatigue spall that occurs near the pitchline is shown in figure 6. This spall is similar to those observed in the rolling-element fatigue tests. The pitchline pitting is the result of a high subsurface shearing stress which develops subsurface cracks. The subsurface cracks propagate into a crack network which results in a fatigue spall that is slightly below the pitchline where the sliding condition is more severe.

Pitting fatigue life results for the gear systems made from VAR CBS 1000M material are shown in figure 5(b). The 10- and 50-percent lives were 44.4×10^6 and 116×10^6 stress cycles (74 and 193 hr), respectively. The failure index was 17 out of 21. There were 7 tooth fracture failures out of the 21 tests, 2 of which were fractures without prior fatigue spalls. Four of the tooth fractures were initiated by a fatigue spall—i.e., the tooth fracture originated at a fatigue spall. Figure 7 shows a typical fatigue spall and tooth fractures for the VAR CBS 1000M. The two fractures without fatigue spalls were considered suspensions as were two tests that completed over 500 hr without failure. The six tooth fractures with this material are an indication of its low fracture toughness and would, therefore, limit its use as an aircraft gear material. In contrast, none of the CVM AISI 9310 or VIM-VAR EX-53 gears failed by tooth fracture. The 10-percent surface fatigue life of the VAR CBS 1000M gears was approximately twice that of the standard CVM AISI 9310 gears. The confidence number was 91 percent, which indicates that the difference is statistically significant. (The confidence number indicates the percentage of time the relative lives of the material

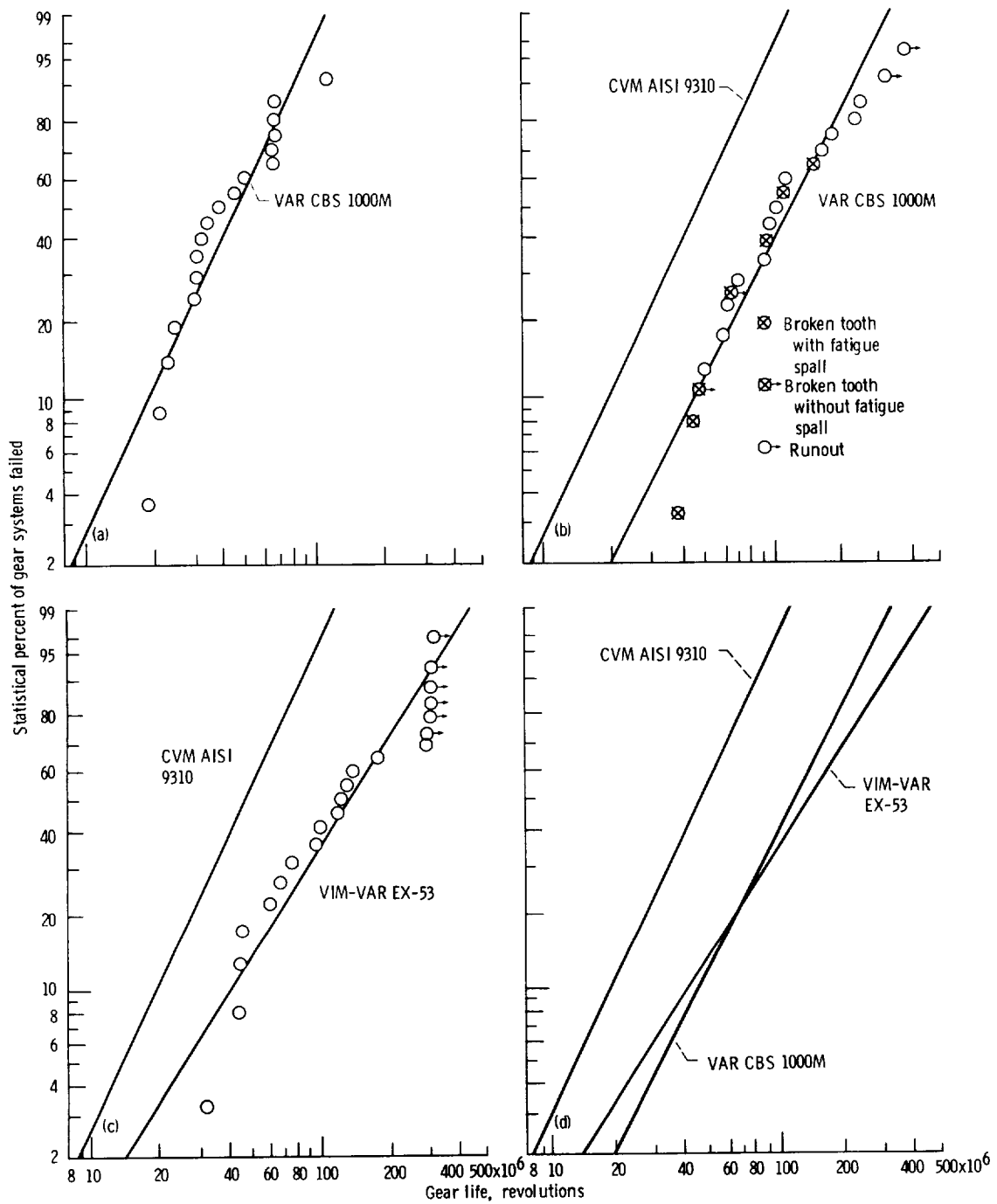

(a) CVM AISI 9310.
 (b) VAR CBS 1000M.
 (c) VIM-VAR EX-53.
 (d) Summary.

Figure 5.—Surface fatigue lives of carburized and hardened CVM AISI 9310, VIM-VAR EX-53, and VAR CBS 1000M test gears. Speed, 10 000 rpm; maximum Hertz stress, 1.71 GPa (250 ksi); temperature, 350 K (170 °F); lubricant, synthetic paraffinic with 5-percent EP additive.

TABLE VI.—SPUR GEAR FATIGUE LIFE RESULTS

[Pitch diameter, 8.89 cm (3.50 in); maximum Hertz stress, 1.71 GPa (248 ksi); speed, 10 000 rpm; lubricant, synthetic paraffinic oil; gear temperature, 350 K (170 °F).]

Material	Gear system life, revolutions		Weibull slope	Failure index (a)	Confidence number at 10-percent level ^b
	10-percent life	50-percent life			
AISI 9310	18.8×10^6	46×10^6	2.1	18 out of 19	---
EX-53	40×10^6	134×10^6	1.5	15 out of 21	87
CBS 1000M	44.4×10^6	116×10^6	1.97	17 out of 21	91

^aNumber of surface fatigue failures out of number of gears tested

^bPercentage of time that 10-percent life obtained with AISI 9310 gears will have the same relation to the 10-percent life obtained with EX-53 gears or CBS 1000M.

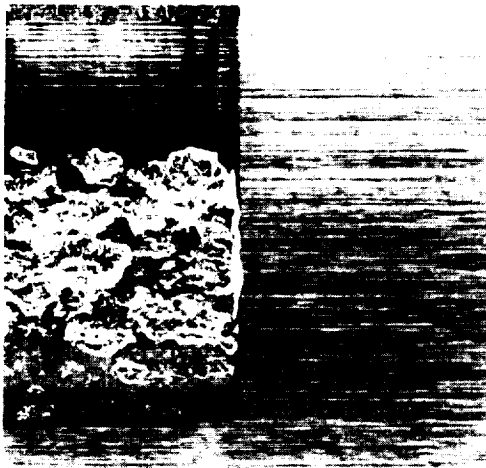
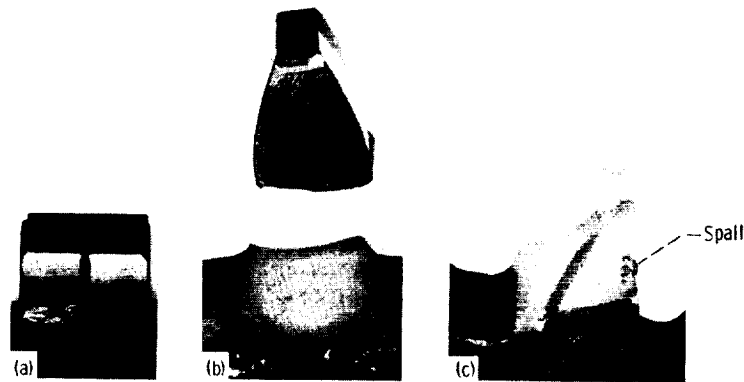

Figure 6.—Typical fatigue spall for AISI 9310 gears.

will occur in the same order.) Since the material has a high temperature hardness above RC 58 to about 533 K (500 °F) (ref. 3), it would be an excellent gear material if the fracture toughness could be improved.

The pitting fatigue life results for the gear systems manufactured from VIM-VAR EX-53 material are shown in figure 5(c). The 10- and 50-percent fatigue lives were 40×10^6 and 134×10^6 stress cycles (67 and 223 hr), respectively. The failure index was 15 out of 21. Figure 8 is a typical fatigue spall for the EX-53 gear material. Six of the 21 tests were suspensions after completing over 300×10^6 stress cycles (500 hr) without failure. There were no tooth fractures with this material even though several tests were run for several hours after a fatigue spall. This is a good indication of the good fracture toughness of the VIM-VAR EX-53 gear material as reported in reference 4. The surface fatigue life of the VIM-VAR EX-53 was approximately twice that of the CVM AISI 9310 standard gear material with a confidence number of 87 percent, which is considered statistically significant. The gear life data are summarized in figure 5(d).



(a) Fatigue spall.

(b) Tooth fracture at root.

(c) Tooth fracture through fatigue spall.

Figure 7.—Gear tooth failures for CBS 1000M.

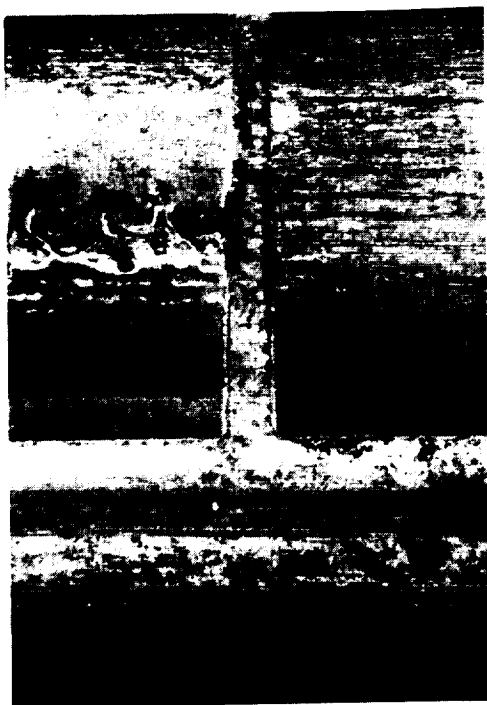

Figure 8.—Typical fatigue spall for VIM-VAR EX-53 gears.

Rolling-Element Life Results

Test bars of VIM-VAR EX-53, VAR CBS 1000M, and VAR AISI 9310 were tested in the RC fatigue tester. There were three lots with three different heat treatments tested for the VAR CBS 1000M material, and one lot and one heat treatment each for the VAR AISI 9310 and VIM-VAR EX-53 materials. The RC bars were tested at a maximum Hertz stress of 4.83 GPa (700 ksi) and a bar speed of 12 500 rpm. The RC tests were run at ambient temperatures (no external heat source) with a MIL-L-7808 G lubricant. The results of these tests are shown in the Weibull plots of figure 9 and are summarized in table VII. These data were analyzed using Weibull plot calculated by the methods of Johnson (ref.

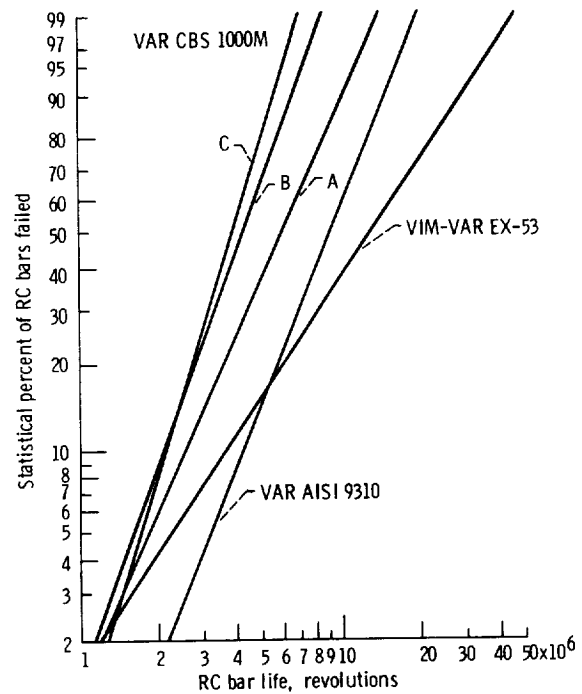

Figure 9.—Rolling-element fatigue life of VIM-VAR EX-53, VAR AISI 9310, and VAR CBS 1000M in rolling-contact fatigue tester. Maximum stress, 4.83 GPa (700 ksi); bar speed, 12 500 rpm; temperature, ambient; lubricant, MIL-L-7808 G.

8). A typical spalling fatigue failure for an RC test specimen is shown in figure 10.

One group (lot A) of the VAR CBS 1000M RC bars had a 10-percent life, 64 percent of that of the baseline VAR AISI 9310 test bar. The confidence number for this difference was 72 percent, which is still considered statistically significant. The other two groups (lots B and C) of the VAR CBS 1000M bars had a 10-percent life, 50 percent of that of the baseline VAR AISI 9310. The confidence number for this difference was 90 percent, which is considered statistically significant. The material composition for three lots of VAR CBS 1000M was not very different, as shown in table II with lot C being

TABLE VII.—FATIGUE-LIFE RESULTS IN ROLLING-CONTACT (RC) TESTER

[Speed, 25 000 stress cycles per min; maximum Hertz stress, 4.83 GPa (700 ksi); lubricant, MIL-L-7808; temperature, ambient.]

Material	Life, millions of stress cycles		Weibull slope	Failure index (a)	Confidence number at 10-percent life level ^b , percent
	10-percent life	50-percent life			
EX-53	3.7	12.9	1.51	9 out of 10	52
CBS 1000M lot —					
A	2.7	6.2	2.3	10 out of 10	72
B	2.1	4.1	2.9		91
C	2.1	4.4	2.6		90
AISI 9310	4.2	9.4	2.3		---

^aNumber of failures out of number of tests.

^bPercentage of time that 10-percent life obtained with AISI 9310 bars will have the same relation to the 10-percent life obtained with EX-53 or CBS 1000M bars.

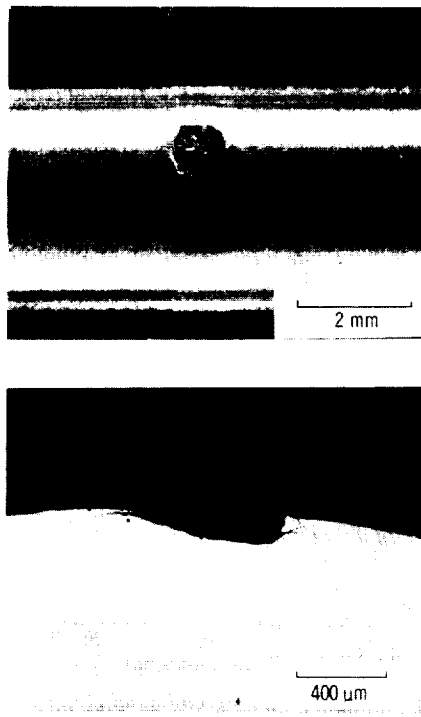

Figure 10.—Typical rolling-element fatigue failure.

slightly different from lots A and B. Therefore, the material differences would not seem to account for the difference in the fatigue life. The heat treatment for lot A had several differences from lots B and C which were fairly close to each other as shown in table III. This difference in heat treatment could account for the life difference between lot A and lots B and C. From this data the VAR CBS 1000M is considered inferior to the VAR AISI 9310. This is not supported by the gear test data which show that the VAR CBS 1000M gears had a little more than twice the fatigue life of the CVM AISI 9310. This difference may be the result of the different types of contact conditions existing in the two types of tests.

The VAR EX-53 RC test bars had a rolling-contact fatigue life that was ~90 percent that of the baseline VAR AISI 9310 test bars. The confidence number for this difference was only 52 percent, which indicates that the difference is not statistically significant. In other words, the lives of the RC bars of EX-53 and 9310 are considered equal. Again this conclusion is not supported by the gear fatigue tests which say that the EX-53 has a fatigue life twice that of the 9310. Again it is evident that the different contact conditions for the RC test and gear test produce different results. In the RC rig test, pure rolling conditions exist with a Hertz stress of 4.83 GPa (700 ksi), while in the gear test, rolling and sliding conditions exist with a Hertz stress of 1.7 GPa (250 ksi). Another difference between the two test methods is the RC bar operating temperature, which is 305 K (90 °F), and the test gear oil outlet temperature, which is 350 K (170 °F).

In addition, the surface temperature is even higher in the gears because of the sliding conditions at the contact zone.

From the previous gear test data it is concluded that the VIM-VAR EX-53 and VAR CBS 1000M materials have a gear surface fatigue life approximately twice that of the CVM AISI 9310. However, the rolling-contact data show that the VIM-VAR EX-53 and VAR AISI 9310 surface fatigue life are approximately equal, while the VAR CBS 1000M has a surface fatigue life approximately one-half that of VAR AISI 9310.

Summary of Results

Spur gear endurance tests and rolling-element surface-fatigue tests were conducted to investigate VIM-VAR EX-53 and VAR CBS 1000M steels for use as advanced application gear materials, to determine their endurance characteristics, and to compare the results with the standard AISI 9310 gear material. Tests were conducted with gears and RC bars manufactured from AISI 9310, VIM-VAR EX-53, and VAR CBS 1000M. The gear pitch diameter was 8.89 cm (3.50 in). Test conditions were an inlet oil gear temperature of 320 K (116 °F), an oil outlet temperature of 350 K (170 °F), a maximum Hertz stress of 1.71 GPa (248 ksi), and a speed of 10 000 rpm. Bench-type rolling-element fatigue tests were conducted at ambient temperature with a bar specimen speed of 12 500 rpm and a maximum Hertz stress of 4.83 GPa (700 ksi). The following results were obtained:

1. The VIM-VAR EX-53 test gears had a gear surface fatigue life of approximately twice that of the CVM AISI 9310 spur gears.
2. The VAR CBS 1000M test gears had a surface fatigue life of approximately twice that of the CVM AISI 9310 spur gears. However, 30 percent of the VAR CBS 1000M gears experienced tooth fracture failure, which limits the use of VAR CBS 1000M as a gear material.
3. The RC fatigue lives of RC bar specimens of VIM-VAR EX-53 and VAR AISI 9310 were approximately equal.
4. In the RC tests the CBS 1000M had a surface fatigue life about 50 percent that of the VAR AISI 9310.

Lewis Research Center
National Aeronautics and Space Administration
Cleveland, Ohio, July 16, 1985

References

1. Townsend, D.P.; and Zaretsky, E.V.: Endurance and Failure Characteristics of Modified VASCO X-2, CBS 600 and AISI 9310 Spur Gears. *J. Mech. Des.*, vol. 103, no. 2, Apr. 1981, pp. 506-515.

2. Townsend, D.P.; Bamberger, E.N.; and Zaretsky, E.V.: A Life Study of Ausforged, Standard Forged and Standard Machined AISI M-50 Spur Gears. *J. Lubr. Technol.*, vol. 98, no. 3, July 1976, pp. 418-425.
3. Jaczak, Chester F.: Specialty Carburizing Steels for Elevated Temperature Service. *Met. Prog.*, vol. 113, no. 4, Apr. 1978, pp. 70-78.
4. Cutler, R.A.; et al.: Elevated Temperature Fracture Toughness and Fatigue Testing of Steels for Geothermal Application. Terratek Report TR-81-97, Oct. 1981.
5. Anderson, Neil E.; and Zaretsky, Erwin V.: Short-Term Hot-Hardness Characteristics of Five Case Hardened Steels. NASA TND-8031, 1975.
6. Nahm, A.G.: Rolling Element Fatigue Testing of Gear Materials. R78AEG476, General Electric; NASA Contract NAS 3-14302) NASA CR-135450, 1978.
7. Dowson, D.; and Higginson, G.R.: *Elasto-Hydrodynamic Lubrication*. Pergamon Press, 1966.
8. Johnson, Leonard G.: *The Statistical Treatment of Fatigue Experiments*. Elsevier Publishing Co., 1964.



1. Report No. NASA TP-2513		2. Government Accession No.		3. Recipient's Catalog No.	
4. Title and Subtitle Surface Fatigue Life and Failure Characteristics of EX-53, CBS 1000M, and AISI 9310 Gear Materials				5. Report Date October 1985	
				6. Performing Organization Code 505-42-94	
7. Author(s) Dennis P. Townsend				8. Performing Organization Report No. E-2578	
				10. Work Unit No.	
9. Performing Organization Name and Address National Aeronautics and Space Administration Lewis Research Center Cleveland, Ohio 44135				11. Contract or Grant No.	
				13. Type of Report and Period Covered Technical Paper	
12. Sponsoring Agency Name and Address National Aeronautics and Space Administration Washington, D.C. 20546				14. Sponsoring Agency Code	
15. Supplementary Notes					
16. Abstract Spur gear endurance tests and rolling-element surface fatigue tests were conducted to investigate EX-53 and CBS 1000M steels for use as advanced application gear materials, to determine their endurance characteristics, and to compare the results with the standard AISI 9310 gear material. The gear pitch diameter was 8.89 cm (3.50 in). Gear test conditions were an oil inlet temperature of 320 K (116 °F), an oil outlet temperature of 350 K (170 °F), a maximum Hertz stress of 1.71 GPa (248 ksi), and a speed of 10 000 rpm. Bench-type rolling-element fatigue tests were conducted at ambient temperature with a bar specimen speed of 12 500 rpm and a maximum Hertz stress of 4.83 GPa (700 ksi). The EX-53 test gears had a surface fatigue life of twice that of the AISI 9310 spur gears. The CBS 1000M test gears had a surface fatigue life of more than twice that of the AISI 9310 spur gears. However, the CBS 1000M gears experienced a 30-percent tooth fracture failure which limits its use as a gear material. The rolling-contact fatigue lines of RC bar specimens of EX-53 and AISI 9310 were approximately equal. However, the CBS 1000M RC specimens had a surface fatigue life of about 50 percent of that of the AISI 9310.					
17. Key Words (Suggested by Author(s)) Rolling-contact fatigue; Spur gears fatigue; Materials: VIM-VAR EX-53; VAR CBS 1000M; CVM AISI 9310			18. Distribution Statement Unclassified - unlimited STAR Category 37		
19. Security Classif. (of this report) Unclassified		20. Security Classif. (of this page) Unclassified		21. No. of pages 14	22. Price A02