

N O T I C E

THIS DOCUMENT HAS BEEN REPRODUCED FROM
MICROFICHE. ALTHOUGH IT IS RECOGNIZED THAT
CERTAIN PORTIONS ARE ILLEGIBLE, IT IS BEING RELEASED
IN THE INTEREST OF MAKING AVAILABLE AS MUCH
INFORMATION AS POSSIBLE

REVIEW OF THE DEVELOPMENT OF SMALL- AND MEDIUM-CAPACITY
GAS TURBINES AT THE MOTOREN- UND TURBINEN UNION

Wolfgang Heilmann



Translation of "Ubersicht uber die Entwicklung von Gasturbinen kleiner und mittlerer Leistung in der MTU", Deutsche Gesellschaft fur Luft- und Raumfahrt, Symposium uber Kleingasturbinen, (German Aerospace Society, Symposium on Small Gas Turbines), Stuttgart West Germany, October 11-12, 1977, DGLR Paper 77-061, pp. 1-30

(NASA-TM-77942) REVIEW OF THE DEVELOPMENT
OF SMALL- AND MEDIUM-CAPACITY GAS TURBINES
AT THE MOTOREN- UND TURBINEN UNION (National
Aeronautics and Space Administration) 31 p
HC A03/HF A01

N86-15314

CSCL 21E G3/07

Unclas
05069

ORIGINAL PAGE IS
OF POOR QUALITY

STANDARD TITLE PAGE

1. Report No. NASA TM-77942	2. Government Accession No.	3. Recipient's Catalog No.	
4. Title and Subtitle REVIEW OF THE DEVELOPMENT OF SMALL- AND MEDIUM-CAPACITY GAS TURBINES AT THE MOTOREN- UND TURBINEN UNION		5. Report Date NOVEMBER, 1985	6. Performing Organization Code
7. Author(s) Wolfgang Heilmann		8. Performing Organization Report No.	10. Work Unit No.
9. Performing Organization Name and Address SCITRAN Box 5456 Santa Barbara, CA 93108		11. Contract or Grant No. NASw- 4004	12. Type of Report and Period Covered Translation
12. Sponsoring Agency Name and Address National Aeronautics and Space Administration Washington, D.C. 20546		14. Sponsoring Agency Code	
13. Supplementary Notes Translation of "Übersicht über die Entwicklung von Gasturbinen kleiner und mittlerer Leistung in der MTU", Deutsche Gesellschaft für Luft- und Raumfahrt, Symposium über Kleingasturbinen, (German Aerospace Society, Symposium on Small Gas Turbines), Stuttgart West Germany, October 11-12, 1977, DGLR Paper 77-061, pp. 1-30 (A78-18702)			
16. Abstract Small- and medium-capacity gas turbines under development for turboprop aircraft and helicopter, as well as for armored and commercial vehicle propulsion, are discussed. Design problems related to axial turbines, ceramic components, regenerative gas turbines, and the optimal expansion ratios for turbines with capacities from 250 to greater than 800 kW are considered; in addition, combustion chamber technology is mentioned. Prototype gas turbines with capacities of 500 to 600 kW or 800 to 1800 kW are described.			
17. Key Words (Selected by Author(s))		18. Distribution Statement Unlimited - Unclassified	
19. Security Classif. (of this report) Unclassified	20. Security Classif. (of this page) Unclassified	21. No. of Pages 29	22. Price

DGLR 77-061

REVIEW OF THE DEVELOPMENT OF SMALL- AND MEDIUM-CAPACITY
GAS TURBINES AT THE MOTOREN- UND TURBINEN UNION

Wolfgang Heilmann
Motoren- und Turbinen Union Munich GmbH

Presentation at the DGLR (German Aerospace Society) Symposium on Small
Gas Turbines, October 11-12, 1977, Stuttgart West Germany.

SUMMARY

As introduction the engineering requirements made of gas turbines of small and medium capacity are defined with respect to their areas of application and from that areas are derived, in which the main design parameters of present and future gas turbines can be found.

In these main design areas we defined, designed and in part already tested "test vehicles", that is gas generators for the particular engines, in order to provide the technological base for future developments. A review is presented of the results obtained, which will be presented in greater detail in additional presentations of this same symposium.

TABLE OF CONTENTS

Organization

1. Introduction	1
2. Application areas and Engineering Requirement	3
3. Design Areas	4
4. Optimum Engine Configurations	5
5. Component- and Test Vehicle Development	6
5.1 Procedure	6
5.2 Key Points of Technological Development	8
5.3 Test Vehicle Testing	9
5.3.1 Test Vehicle MTU 7042	10
5.3.2 Test Vehicle IA	11
5.3.3. Test Vehicle IB	11
5.3.4 Test Vehicle (Ceramic Components)	12
6. Outlook	14
7. References	14

1. Introduction

Since a few years ago MTU has conducted, in the area of small and medium capacity gas turbines in addition to the development of the MTU 7042, a turbine with a power of 350 hp and regenerative heat exchanger, an extensive program with the goal of creating the technological base for future development projects of this power class. /1*

Here a guide line in the conduct of this program is the requirement that the results obtained can find application in a number as high as possible of conceivable or probable future projects since no defined engineering requests from potential customers existed. Another basic requirement is that analytically and above all design-wise developed solutions must be confirmed not only in component tests under ideal conditions, but also experimentally under actual conditions close to operating conditions. Such results are not only the criterion for the recognition of a team as competent partner in a joint development - which are the rule today because of the high costs of major engine developments - but they are also the prerequisite for a realistic estimate of development costs and risks.

In the following we shall now discuss the procedure during the conduct of this program and give a review of the results obtained therein. During the further course of this conference coworkers from the MTU will report some of these results in still greater detail. Here in particular such development problems will be treated which have not already been reported elsewhere.

*Numbers in margin indicate foreign pagination

2. Application areas and engineering demands

As shown in figure 1 the applications can basically be divided into two groups,

- a) into aviation applications, i.e., turbine engines as power plants for single- or multiple engine helicopters as well as turboprop engines for airplanes. In order to keep development costs low, newly developed turboprop engines and turbine engines have the same basic engine and differ only with respect to reduction gears.
- b) into vehicle applications for trucks, for which a relatively small power range is of interest, and for armored vehicles, for which engines in various power ranges up to 1800 kW and beyond are considered. It must be mentioned that until now there has been no mass production for any vehicle engines.

For aviation applications, in addition to low operating costs (fuel, maintenance costs, procurement costs), low weight and high emergency power, especially for turbine engines, are the essential requirements.

In applications for road vehicles the engineering demands are derived directly from the values achieved by today's Diesel engines and those to be achieved in the foreseeable future through further improvements of the Diesel engine. Here fuel consumption comparable to that of the Diesel engine is the controlling parameter for design and chances of achievement. This is true particularly for truck engines. In order to be able to satisfy the demand for low fuel consumption, the utilization of the heat in the exhaust gas by the use of a heat exchanger integrated into the gas turbine is essential.

3. Design areas

Figure 2 shows in a plot of specific fuel consumption against specific power, the characteristic pressure ratios of gas turbines, which were designed for the applications and demands shown in figure 1 for two different turbine inlet temperatures. They are the results of cyclic-process calculations on the basis of component efficiencies achievable today taking into consideration bleed-air removal for component cooling. From the figure one can derive the following:

- a) With gas turbines without heat exchangers one can attain no specific fuel consumptions which would be comparable to those of the Diesel engine with ca. 210-220 g/kWh at a power of 250 kW. Such values can be attained, e.g., with regenerative gas turbines of 250 kW power only by the application of ceramic materials and at turbine inlet temperatures of 1550 K.
- b) The specific power increases and the specific fuel consumption decreases substantially with design power because secondary flows and boundary flows have greater relative expansions as the result of decreasing stream channels, because the Reynolds numbers become smaller and clearances and tolerances become relatively greater. The optimum pressure ratio also increases simultaneously with increasing engine power and temperature.
- c) Optimum pressure ratios for engines without heat exchangers lie at 500 kW near 7 - 12, whereby it must be noted that out of consideration for price and maintenance costs one hardly chooses pressure ratios above 9, since then a two-stage gas generator turbine and a multi-stage compressor would be required. In general turbine cooling is also prohibitive so that T_{t3} would be limited to about 1300 K.

For 1100 kW design power the optimum pressure ratios lie between 12 and 14 and one tries for high temperatures up to $T_{t3} = 1550$ K because the thus possible increase of the specific power generally justifies the expenditures for turbine cooling.

- d) For engines with heat exchanger the optimum pressure ratios lie at 250 kW design power, which is chosen for truck gas turbines, between 4 and 6 if a regenerator with about 90% efficiency is used.

For a design power of 1100 kW the values lie between 8 and 12, if a recuperator - the only construction type for heat exchangers to be considered in this power range - with an efficiency of 80% is used.

4. Optimum engine configurations

However, the final definition of the main parameters pressure ratio and turbine inlet temperature governing the design does not result from cyclic-process calculations, but in an iteration process which is affected to a special degree by the design. It makes visual the design limits set by strength and dynamics as well as by justifiable fabrication costs and is also affected by available development time and financial means.

Figure 3 shows configurations of engines to be possibly developed in the future. Their main data lie within the optimum design ranges and were established in the described iteration processes.

This is a shaft turbine, designed for pressure ratios of 7- 9 and $T_{t3} \sim 1300-1400$ K, which can be used, depending on the engine configuration chosen, at the output shaft directed toward the front as turbine engine or turboprop engine. With a single-stage centrifugal compressor, annular combustor, single-stage gas generator

turbine and single-stage output turbine, the engine is built up with the lowest possible number of stages.

The engine shown on the right of the picture, designed for pressure ratios of 4-5 and $T_{t3} \sim 1300$ K for road vehicle applications, has the same minimum number of flow-machine components. However, it has a regenerative heat exchanger, a tubular combustor instead of an annular combustor and an adjustable power turbine, which in regenerative engines brings about more favorable part-load consumptions and also shorter acceleration times.

The engine shown in the lower part of the figure was designed for the higher power range $P \sim 800$ kW. Because of the higher pressure ratio of 12 - 14 this engine, compared to the single stage engine shown in the upper left, has in addition to the centrifugal compressor an upstream axial compressor and one each additional gas generator- and power turbine stage. In addition cooling is required for the gas generator turbine at the temperatures selected.

For the case where the engine is equipped with heat exchanger, which is necessary not only for road vehicle applications, but also can be attractive for the achievement of particularly low fuel consumptions for aircraft applications, a recuperator and power turbine guide vane adjustment are added. In that case, because of the then lower optimum pressure ratio of 8 - 10 a few axial compressor stages can be eliminated.

5. Component- and test carrier development

/6

5.1 Procedure

Since because of its size and financial potentials the MTU cannot make preliminary developments for all configurations described in the preceding section, we proceeded as follows:

- a) The technology necessary for a successful development was defined and key points were placed wherever we saw a chance to reach and maintain a maximum technological position.
- b) In key point areas, in which the technology considered to be necessary could not be worked out within contract developments, we attacked the development problems with our own means.
- c) New, in part also current contracts for the conduct of component- and technology tasks could be tuned extensively to the total concept because the particular sponsoring agencies could also avail themselves by this tuning of information obtained from tasks financed in other ways.
- d) The cooperation with research was expanded for the benefit of both.
- e) By the working out of basic information from the physical processes, by thorough design and theoretical working up of newly to be developed components and by experimental testing to be conducted only after this and by intensive analysis of the results obtained with the most modern measurement procedures, we succeeded in keeping the expenditures substantially smaller than by employing an accentuated empirical-experimental procedure.
- f) Through design, fabrication and buildup of test carriers, the opportunity is provided to test results from technology investigations under realistic conditions close to actual operating conditions. In this way the development of the fabrication processes is advanced at the same time and a first estimate of the production costs becomes possible.

/7

5.2 Key points of the technological development

Figures 4 and 5 give a review of the key point areas, in which special efforts are made to work out the technology considered to be necessary for potential applications. They are:

- a) Centrifugal compressor with backward bent blades from investment castings made of aluminum, titanium and constructed for pressure ratios up to 7.
- b) Gas generator turbines with cooled inlet vanes and cooled turbine wheel made as investment casting and in finished construction with the use of powder-metallurgy produced plates and new vane materials in conjunction with progressive joining methods.
- c) Adjustable power turbine, and in particular the mechanical development of the inlet guide vanes.
- d) Combustion chambers as tubular- and reverse-flow annular combustors. Essential goals of the development are high useful life, i.e., low wall temperatures even for high combustor inlet-air temperatures as are encountered with upstream heat exchanger and the reduction of the emission of harmful exhaust gases.
- e) Heat exchangers *), and namely ceramic regenerators for inlet temperatures up to 1300 K as well as metallic and ceramic recuperators.

*) Work on heat exchanger seal systems for regenerators and recuperators is being conducted by the Daimler-Benz AG.

Until now engine data were specified in many places on the basis of results determined under ideal conditions in rig tests, i.e., with compressors in thick housings, with ideal onflow conditions, at low mechanical stresses and with turbines, which were tested in a cold atmosphere and with combustion chambers, which were tested under atmospheric conditions. It was found that results thus obtained are not sufficient as base for a prediction of the operating properties as well as for a realistic estimate of the development risks and the development costs.

For design pressures and temperatures, deviations from the theoretical assumptions are obtained under operating conditions especially for the following items:

- Plays and clearances of compressor- and turbine guide vanes and wheels as well as at labyrinth seals and seals which occur primarily because of the high heat expansions of the components.
- Temperature- and pressure gradients in radial and circumferential direction which cannot be determined in advance.
- Leaks in seals, plug connectors and labyrinths as well as in the heat exchanger.
- Nonsteady-state effects.

These factors are responsible for the fact that

- the calculated power- and consumption values are not attained (design operating point is not reached if the components are not tuned to one another and if the air bleeds are too high),

- if the handling of the engine is insufficient,
- if unexpected mechanical problems develop.

/9

5.3.1 Test vehicle MTU 7042

The low-power industrial gas turbine MTU 7042 developed by MTU, whose development as of status of 1976 was described by Heilmann and Hagemeister [1], is the test vehicle used for the development of component technology for turbines with heat exchangers of 250 - 350 kW.

This turbine is shown in figure 6 as a perspective drawing. It attains the design power of 350 hp = 258 kW and is at present undergoing an extensive running test.

Schmidt-Eisenlohr [2] are reporting in detail concerning the development of the new centrifugal compressor with a pressure ratio of 4 installed in this test vehicle, which for a design rpm attains efficiencies of 83% and which exhibits a very broad performance field. Here they discuss primarily the effect of engine conditions on the properties of the centrifugal compressor.

The combustor has an especially low exhaust gas emission. With $H_c + N_o$ -emissions of 4.18 g/hph it is below the limiting values announced by the lawmakers for the next few years. At present it is still made of metal, but is to be replaced soon by an already being tested version made of ceramics, as described by Trappmann in [3].

The mechanical development and testing of the adjustable guide vanes of the power turbine and the elimination of the vibration dangers at the shroud-free power turbine were discussed by Hourmouziadis et al. in [4].

The test vehicle MTU 7042 serves at the same time also for the testing of new ceramic regenerator plates and of the particularly critical seal systems developed by the Daimler-Benz AG and discussed by Heuer and Wiegard in [5].

/10

5.3.2 Test vehicle IA

Figure 7 shows a cross-sectional view of the test vehicle IA, which corresponds to the gas generator of a 500-kW engine. It consists of a centrifugal compressor machined from titanium with a pressure ratio of 7, whose design efficiency is $\eta_{is} = 79\%$ and whose specified performance map was confirmed in the component test stand, a highly loaded reverse-flow annular combustor and a single-stage transonic gas generator turbine with cooled guide wheel, which is cast integrally just as the turbine wheel.

The auxiliary systems, pumps, controllers are driven by a standard auxiliary engine. The test vehicle, which is shown in figure 8, is instrumented very extensively and flanged to a large-volume air-inlet housing. It is being used at present for a major test program.

From these investigations Dietrichs, Hourmouziadis and Rademacher [6] are giving detailed reports of the results of aerodynamic investigations with transonic gas generator turbines taking into account the effect of guide wheel cooling.

As the next tasks we are planning consumption optimizations and the testing of the modules and construction elements which are of essential importance for the test vehicle IB.

5.3.3 Test vehicle IB

/11

The test vehicle IB shown in figure 9 is built up on the information obtained with test vehicle IA, especially in the area of the combustor, the turbine-inlet guide wheel as well as the centrifugal compressor. It is used for the testing of the technology of aircraft gas turbines in the range from 800 - 1800 kW and can also be used for the development of gas turbines with recuperative heat

exchangers. Here the primary goal is the achievement of specific fuel consumptions in the range from 270 - 280 g/kWh as well as lower maintenance costs.

In the development of the axial-centrifugal compressor planned for this test vehicle, the information gained from the centrifugal compressor development is combined with the results of the axial compressor development worked out in extensive thrust engine programs.

Figure 10 shows a high-pressure axial compressor 180 mm long developed at MTU, which produces a pressure ratio of 3.5, which has been optimized with respect to maintaining clearances and which exhibits excellent efficiencies of 85 % as well as a pump limit reserve SM of 40 %.

The information necessary to achieve gas generator turbine cooling was obtained in several programs financed by the public sponsor. Koehler et al. are reporting about this in [7].

Figure 11 shows test- and calculation results from an investigation for optimizing the cooling of a gas generator turbine for a thrust engine designed for $T_{t3} > 1600$ K, which has about the same dimensions as the one installed in this test vehicle.

The report by Adam [8] discusses in detail joining methods, which were used to produce the test vehicle. In addition components made of new materials, such as from powder metallurgy, are to be tested. /12

5.3.4 Test vehicle ceramic structural parts

High turbine-inlet temperatures lead to favorable fuel consumptions and specific powers, i.e., to low weight and structural

volume. However, they require at the same time high expenditures for component cooling and for cooling-air inlets and force one to use exotic, expensive alloy parts, becoming ever more scarce, in the heat-resistant materials. It would constitute a big jump in the improvement of all properties of today's gas turbines if one could substitute for these materials and do without component cooling.

Therefore we undertook in 1974 with the support of the BMFT together with other companies and institutes a program, scheduled for three years, for the development of ceramic combustion chambers, turbines and gas passages as shown in figure 12.

Trappmann [3] is presenting a detailed report about the results obtained by MTU in this program which at present is very promising. The goal of the second three-year program, started in this year, is to test these components under engine-specific operating conditions.

For this we used the ceramic test vehicle shown in figure 13, which is built up in addition to the ceramic components to be tested, of established components of the MTU 7042 and the Allison C 20 engine built by MTU under license agreement as well as some new components designed especially for this test vehicle.

In parallel with the above described tasks we are conducting /13 projects which lie especially in the design area and which are significant for all test vehicles. Let us list here the testing of air-cushioned bearings made of metal or ceramics as well as experimental investigations with belt drives as replacement for conventional wheel drives. Results of these investigations are discussed by Hagemeister in [9].

6. Outlook

An engine with fiber-reinforced compressor-inlet stages, with compressor-outlet stages made by powder metallurgy, with ceramic hot parts, with air-cushion bearings, with dry belt drives without oil and running without complicated cooling systems - this may sound at the moment like a vision by an unrealistic engineer not confronted with the daily problems of a development. However, the subject initial results absolutely arouse the hope that at least a part of the above addressed technologies can be realized. This will then contribute to a substantial degree to make the gas turbine still more economical in its present application areas and to open up new application areas for it.

7. References

/14

- [1] Heilmann W.
Hagemeister K. Design and Development of Small
Regenerative Gas Turbines at MTU
ASME 77-GT-103
- The Development of Low-Capacity
Gas Turbines with Regenerative
Heat Exchangers at MTU
MTZ 1977, volume 5 and 7/8
- [2] Schmidt-Eisenlohr U.
Schuster P. New Results from the Centrifugal
Compressor Development
DGLR-Report 77-065
- [3] Trappmann K, Status of the Development of
Ceramic Components
DGLR-Report 77-072

- [4] Hourmouziadis J. et al. Experience with a One Stage Variable Geometry Axial Turbine Meeting: Variable Geometrie and Variable Cycle Engines. Paris Sept.76
- [5] Heuer j.
Wiegard K. More Recent Developments on Heat Exchangers for Road Vehicle Gas Turbines
DGLR-Report 77-075
- [6] Dietrichs H.-J.
Hourmouziadis J.
Rademacher O. Findings in the Area of Turbine Aerodynamics from the Analysis of the Component- and Test Vehicle Testing
DGLR-Report 77-065
- [7] Koehler H. et al. Hot Cascade Test Results of /15 Cooled Turbine Blades and Their Application to Actual Engine Conditions
Paper presented to AGARD-PEP Symposium Ankara , Sept. 11
- [8] Adam P. Application of New Joining Techniques in Smaller Gas Turbines
- [9] Hagemeister K. Development of Progressive Components as Basis for Future Small-Capacity Gas Turbine Designs
DGLR-Report 77-069

Luftfahrt - Anwendungen:

Fahrzeug - Anwendungen:

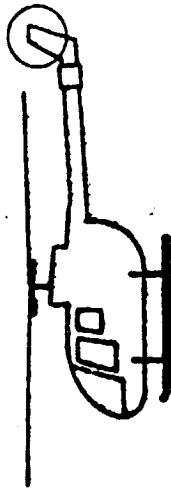

300 - 1800 kW

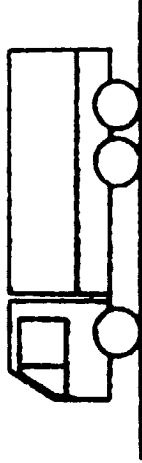

250 - 450 kW



300 - 700 kW

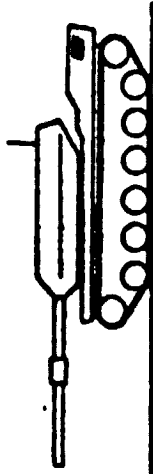

250 - 1800 kW

1. aviation applications

2. road vehicle applications

Hauptforderungen:

3. requirements

- 4 ● niedrige Betriebskosten (Brennstoff, Wartungskosten, Preis)
- 5 ● geringes Gewicht (Bauvolumen)
- 6 ● hohe Notleistung
- 7 ● Brennstoffverbrauch $\hat{=}$ Diesel
- 8 ● Betriebskosten
- 9 Preis $\hat{=}$ Dieselmotor (für LKW)
- 10 Lebensdauer
- 11. shaft engines
- 10. life expectancy

Wellentriebwerke

11. shaft engines

Figure 1

(Anwendungen - Forderungen) (applications - demands)

11

1

4. low operating costs (fuel, maintenance costs, price) 7. fuel consumption = Diesel

5. low weight (structural volume)

8. operating costs

9. cost = Diesel engine (for trucks)

/16

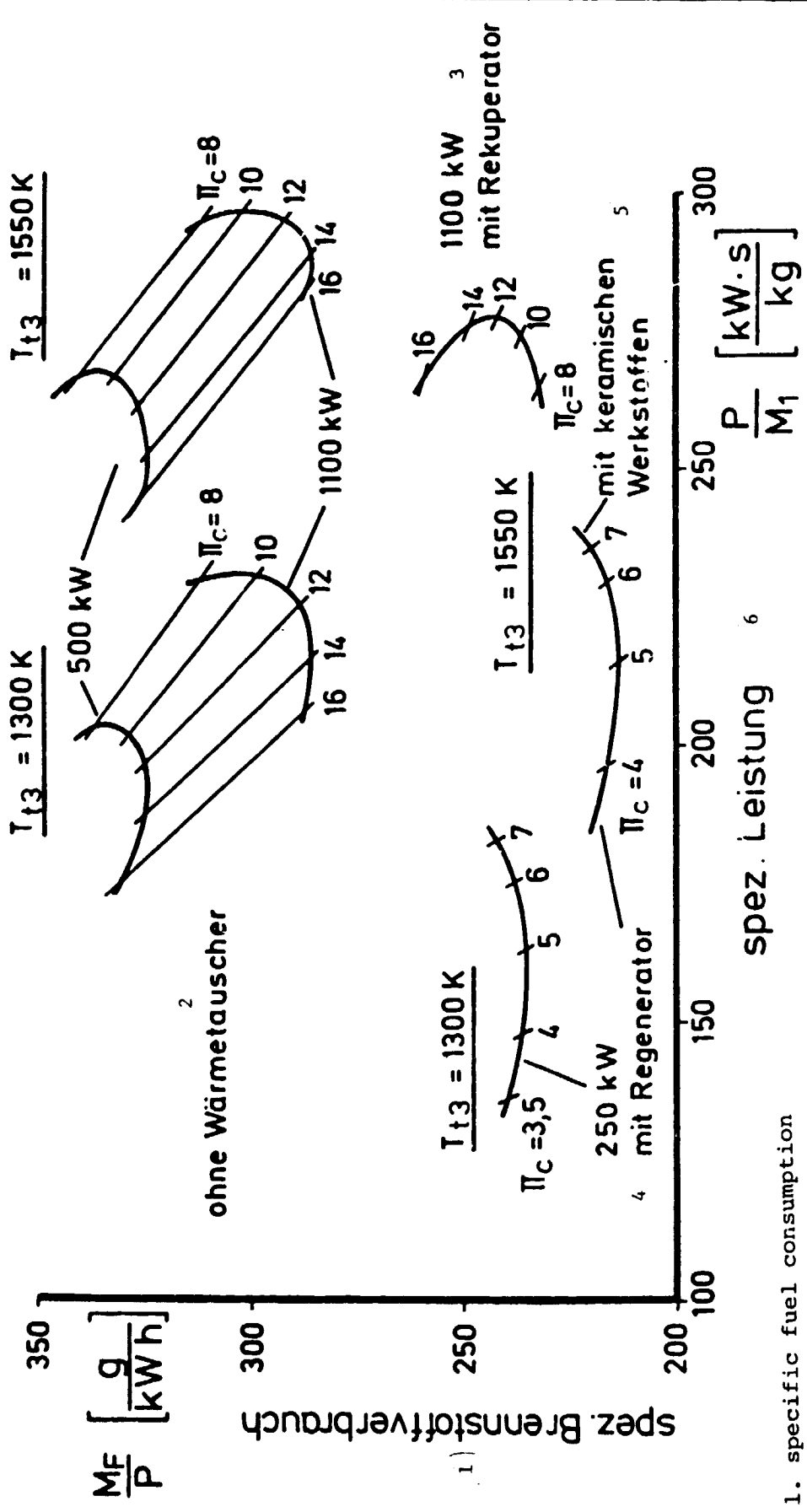

Figure 2
2

Wellenturbinen
(Auslegungsbereiche)

- 2. without heat exchanger
- 3. with recuperator
- 4. with regenerator
- 5. with ceramic materials
- 6. specific power
- 7. shaft turbines (design areas)

(1)

Wellenturbine : 500 kW
 $\Pi = 7-9 ; T_{t3} = 1300 - 1400 \text{ K}$

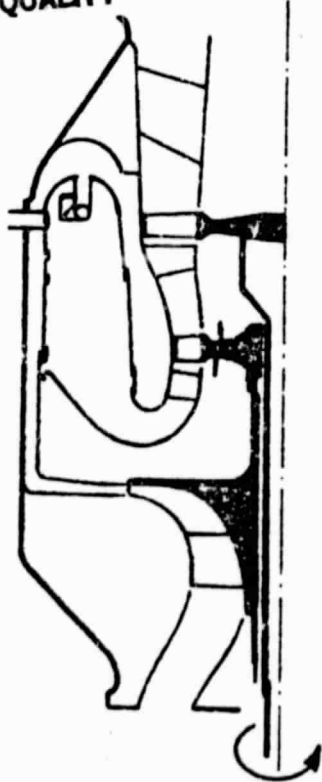

1. shaft turbine

ORIGINAL PAGE IS
OF POOR QUALITY

LKW - Turbine : 250 kW mit Regenerator 2.
 $\Pi = 4-5 ; T_{t3} > 1300 \text{ K}$

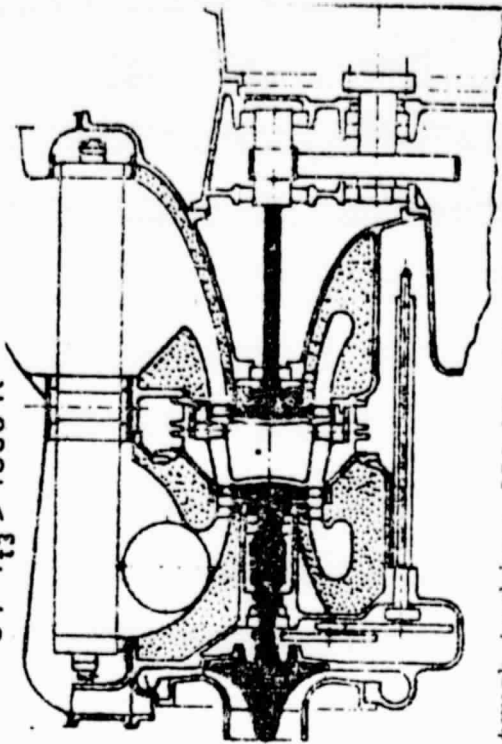

2. truck turbine: 250 kW with regenerator

Wellenturbine : > 800 kW 3 3. shaft turbine
 $\Pi = 10-14 ; T_{t3} = 1450 - 1550 \text{ K}$

mit Rekuperator u. verstellb. Arbeitsturbine

$\Pi = 8-9 ; T_{t3} = 1450 - 1550 \text{ K}$

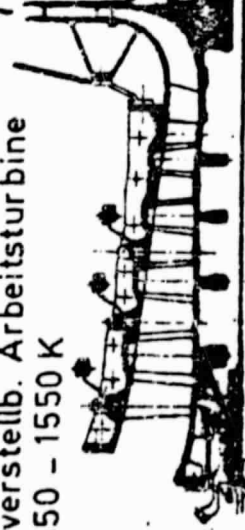

with recuperator and adjustable power turbine

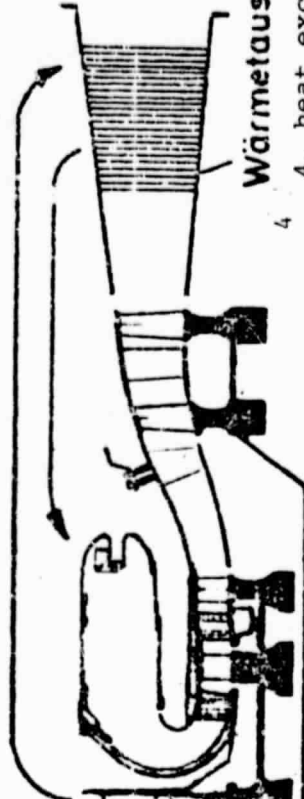

Wärmetauscher

4 4. heat exchanger

Wellenturbinen

(Konfigurationen) 5. shaft turbines (configurations)

Figure 3

3

ORIGINAL PAGE IS
OF POOR QUALITY

Verdichter

1. compressor
2. Axialteil
3. Radialteil
3. centrifugal part

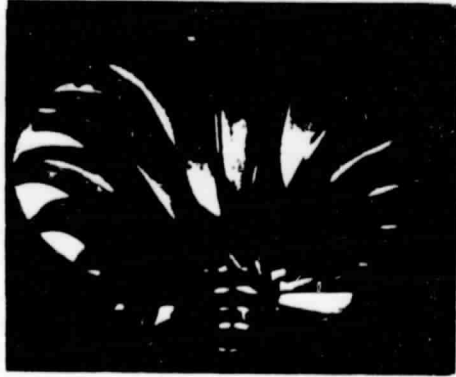

- Verständnis der physik. Vorgänge im Laufrad und Diffusor 7
- Technologie zur Herstellung kostengünstiger, leichter Laufräder 8

Turbinen

4. turbines
5. GG-Turbine
6. Arbeitsturbine
6. power turbine

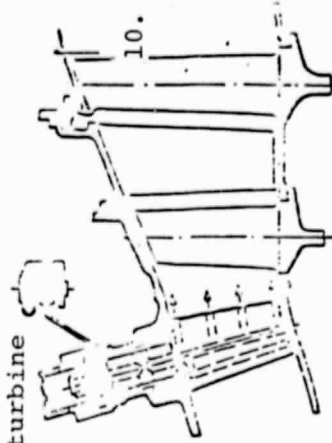
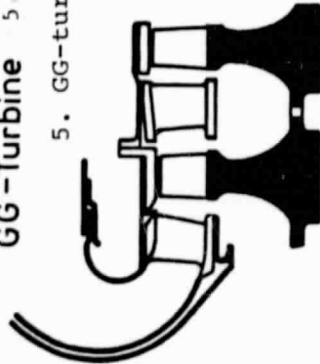

- Gute Wirkungsgrade bei hohen Belastungen 9
- Hohe „Low Cycle Fatigue“ Festigkeit der Scheiben strength of disks 10
- Zuverlässige Verstellung ohne Wirkungsgradverluste (Arbeitsturbine) 11

11. reliable adjustment without loss of efficiency (power turbine)

12. component technology

Komponententechnologie

compressor - turbine

Verdichter - Turbine

Figure 4

12

4

7. understanding of the physical processes in turbine wheel and diffuser

8. technology for production of cost-effective light weight turbine wheels

Brennkammer

1, 1. combustion chamber

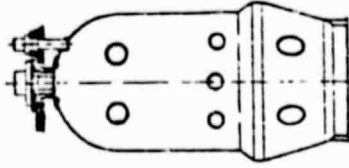
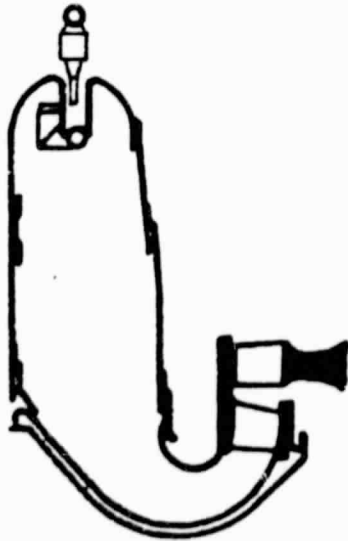

- Lebensdauer bei hohen Brennkammerluft-Eintrittstemperaturen (optimale Wandkühlung)

- Niedrige Emission (LKW)

4. low emission (trucks)

Wärmetauscher

2 2. heat exchanger

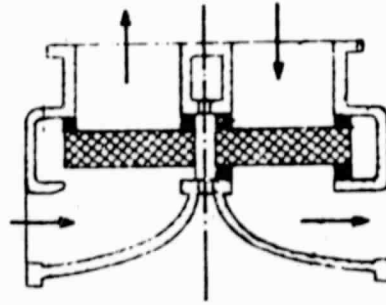

- Regenerator für Eintrittstemperaturen von 1280 °C, minimaler Dichteverlust, lange Lebensdauer

- Metallischer Rekuperator

- Keramischer Rekuperator

7. ceramic recuperator

Komponententechnologie

Figure 5

8

5

8. component technology
combustion chamber - heat exchanger

Brennkammer - Wärmetauscher

3. life expectancy at high combustor-inlet air temperatures (optimum wall cooling)
5. regenerator for inlet temperatures of 1280°C, minimum compression loss, long life expectancy

ORIGINAL PAGE IS
OF POOR QUALITY

Gasturbine MTU 7042

Gas turbine MTU 7042

Figure 6
6

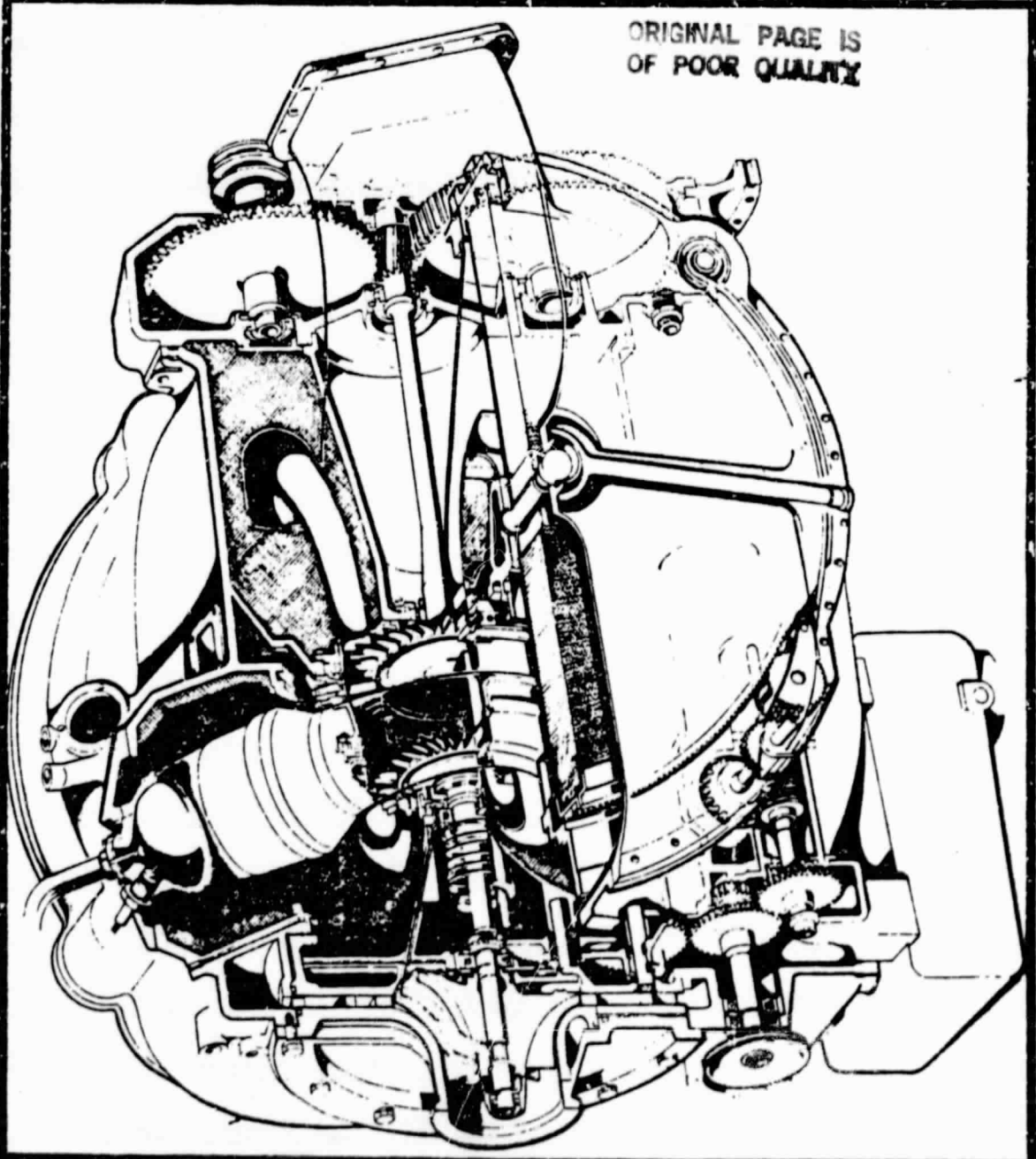

ORIGINAL PAGE IS
OF POOR QUALITY

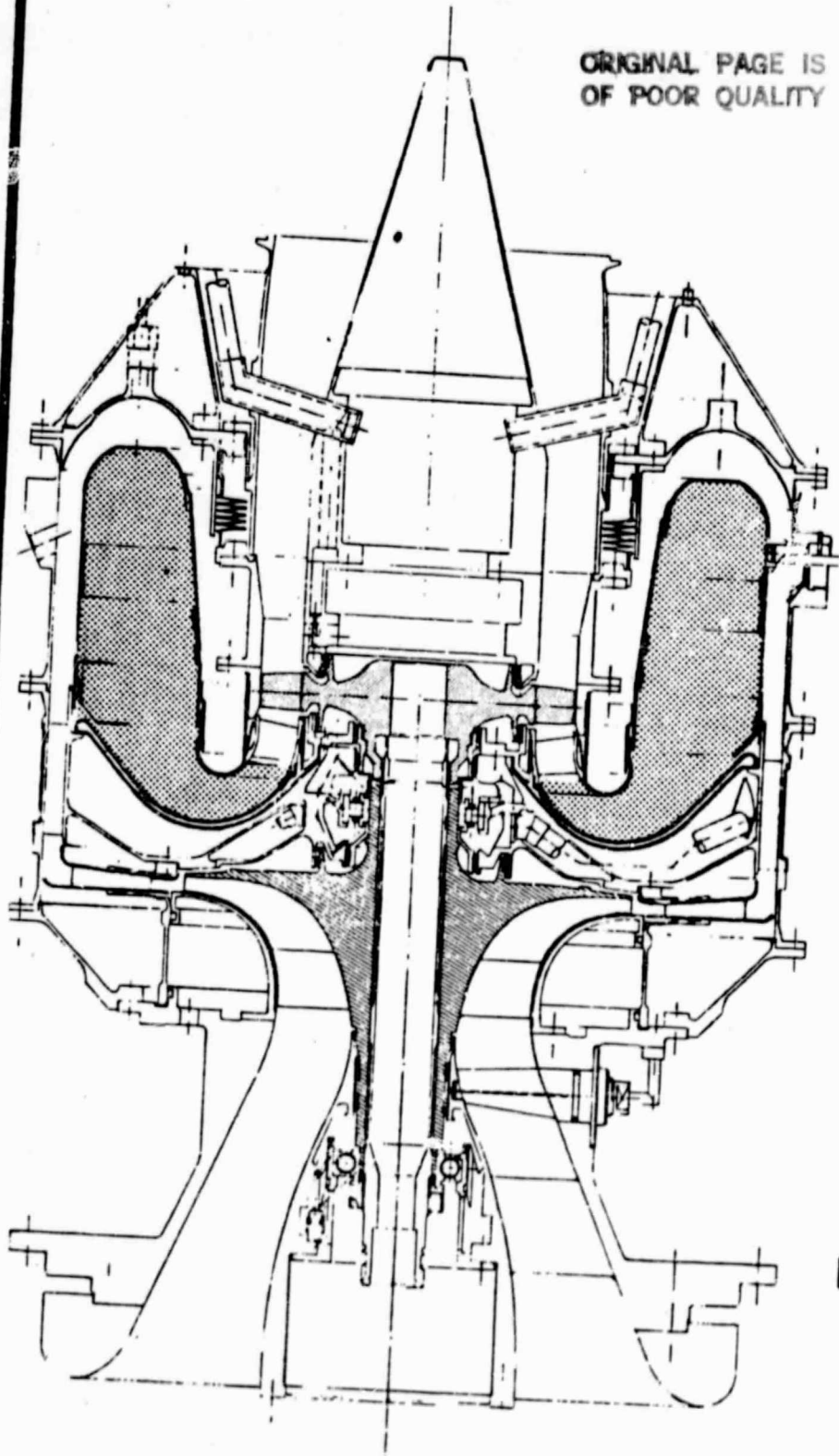

$\Pi \sim 7$ $T_3 = 1320 \text{ K}$ $P \approx 500 - 600 \text{ [kW]}$

Versuchsträger Ia
Test vehicle Ia

Figure 7
7

Versuchsträger

I a

Test vehicle Ia

ORIGINAL PAGE IS
OF POOR QUALITY

8

/23

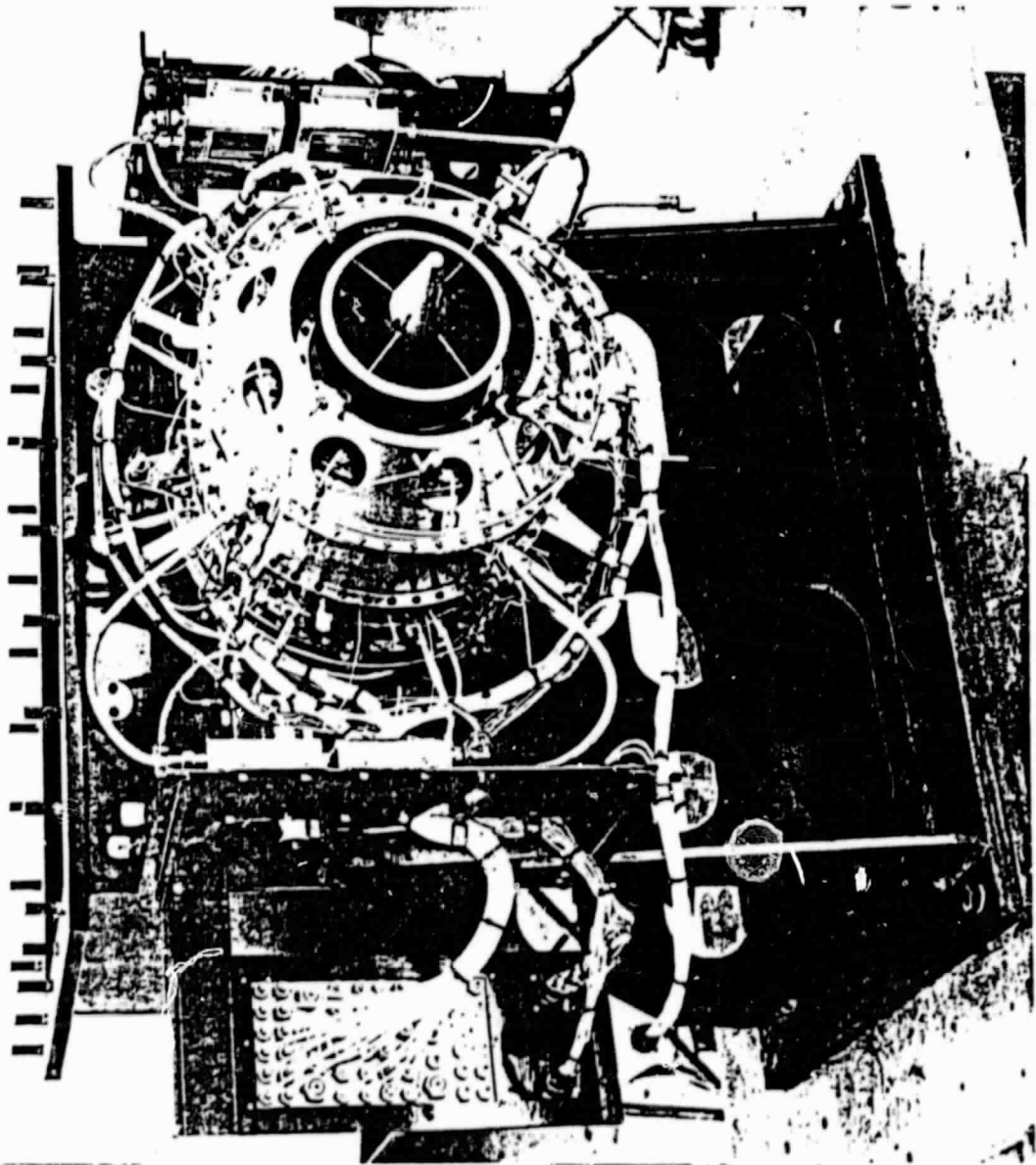

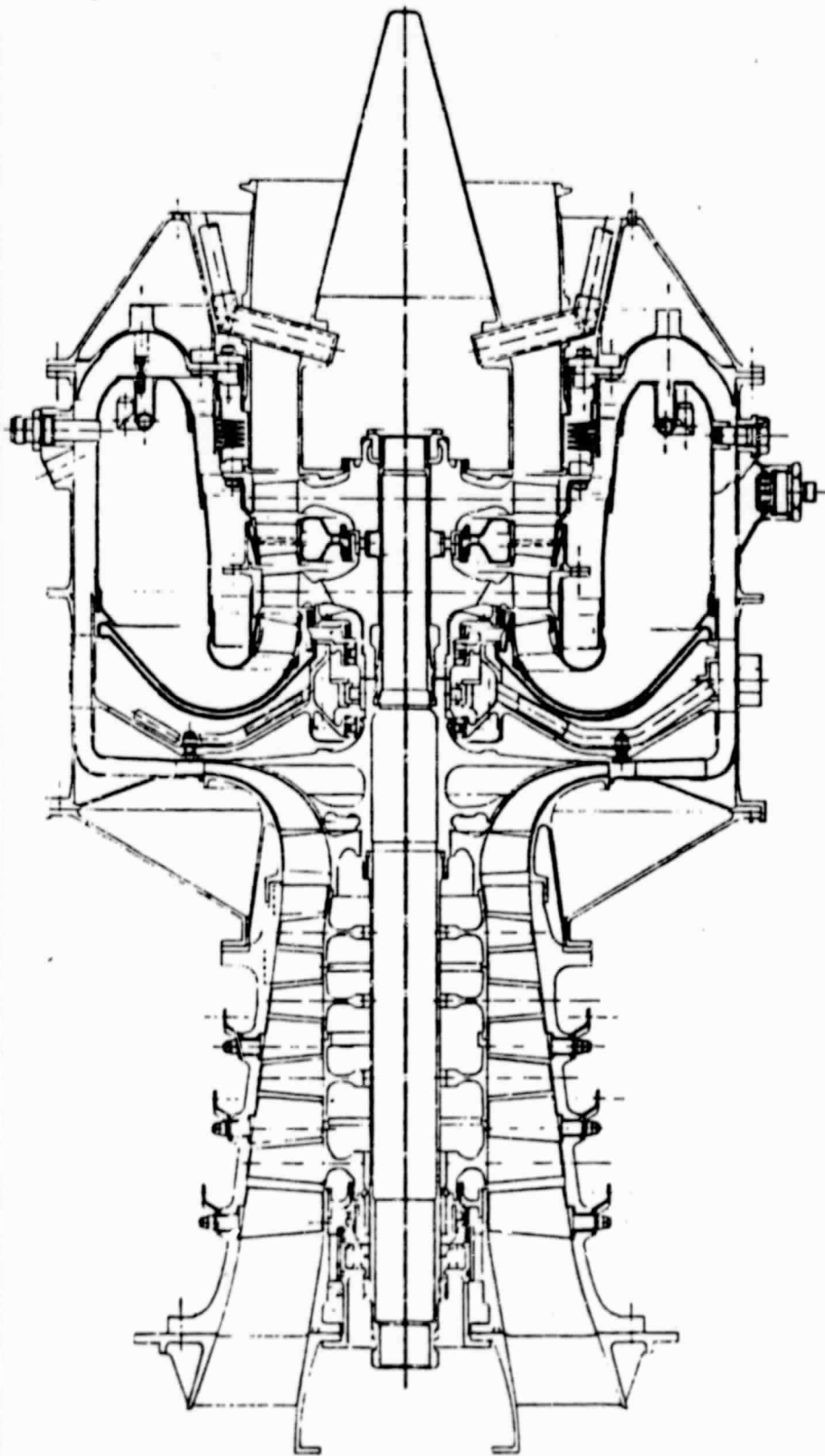

$\Pi = 12 - 14$ $T_3 < 1650 \text{ K}$ $P = 800 - 1800 \text{ [kW]}$

Versuchsträger Ib
Test vehicle Ib

Figure 9
9

2. shrinking during deceleration

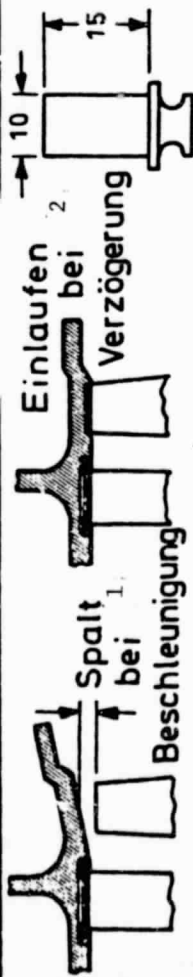

1. slot at acceleration

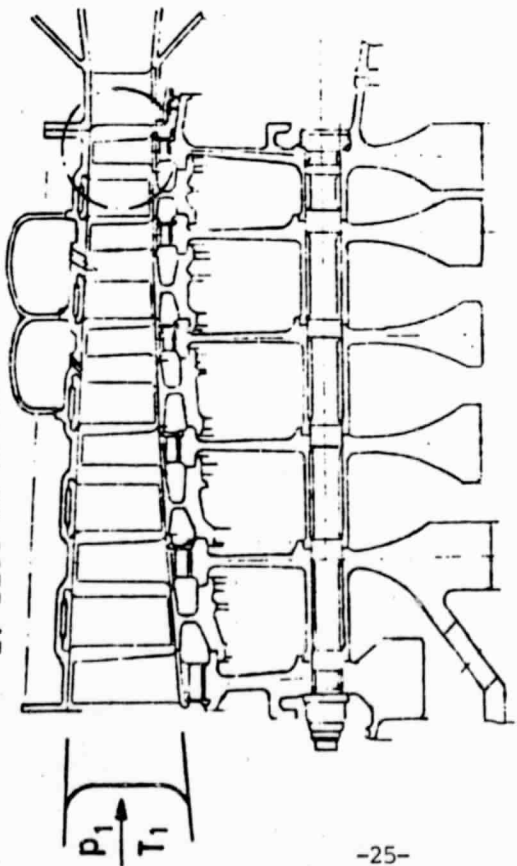

4. pressure ratio ~ 180

Druckverhältnis : $\sim 3,6$

Durchsatz 5 : $\frac{m\sqrt{T}}{P} \sim 1,2 \left[\frac{\text{kg } \sqrt{\text{K}}}{\text{s kPa}} \right]$

5. throughput

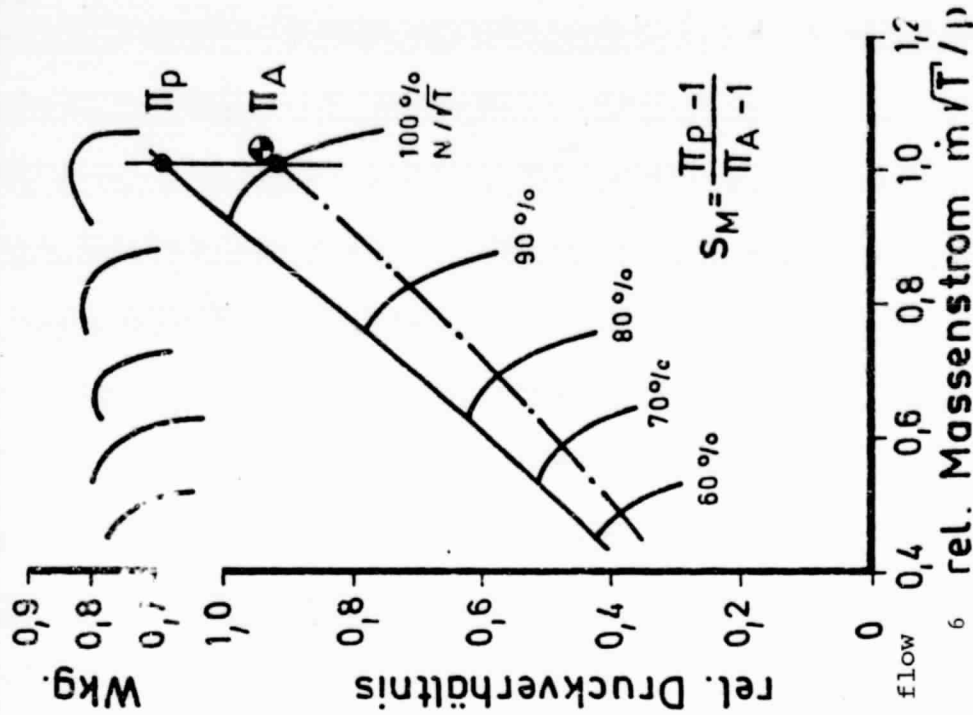

3. rel. pressure ratio

6. rel. mass flow

6 rel. Massenstrom in \sqrt{T}/P

Figure 10

Axialverdichtertechnologie

(aus Entwicklungsprogrammen für Schubtriebwerke)

7. axial compressor technology (from development programs for thrust engines)

1. cooling configuration optimization with thermal paints
Kühlkonfigurationsoptimierung mit Thermofarben

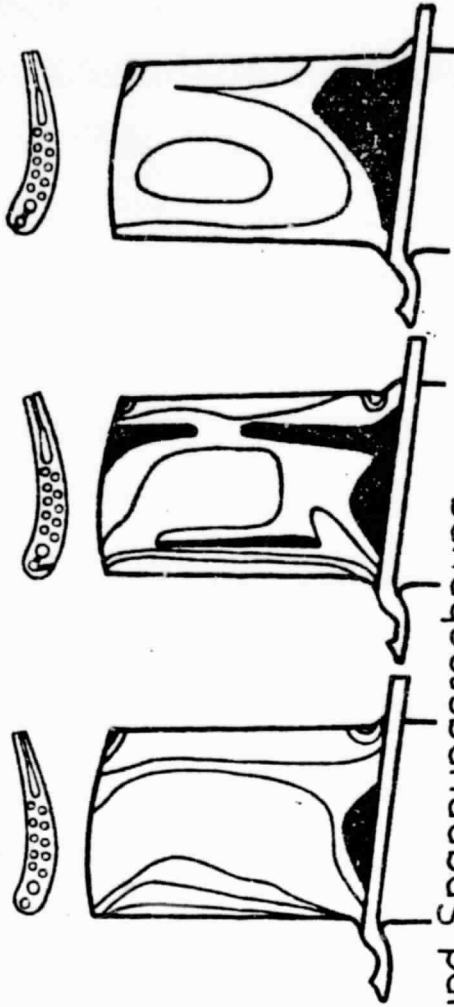
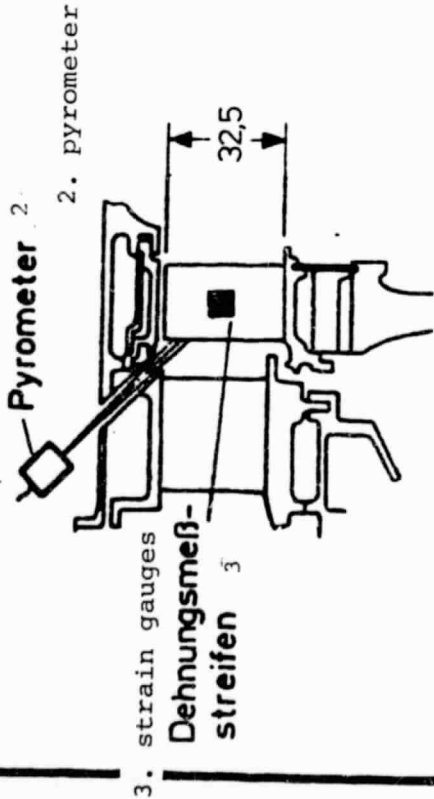

4. Temperatur- und Spannungsrechnung

4. temperature- and stress calculation 0,9

ORIGINAL PAGE IS OF POOR QUALITY

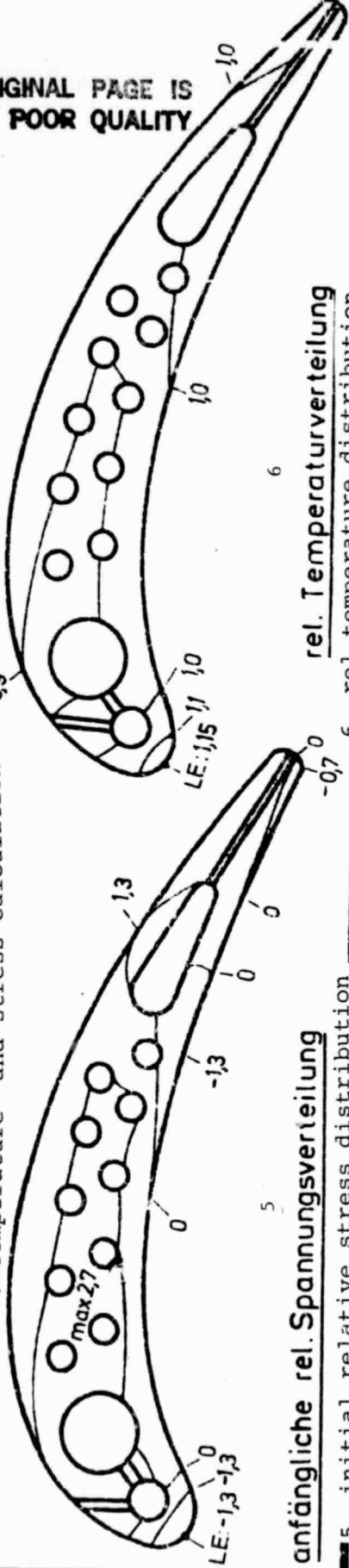

Figure 11
 11

Bauteilkühlungstechnologie
 (aus Entwicklungsprogrammen für Schubtriebwerke)

7. component cooling technology (from development programs for thrust engines)

ORIGINAL PAGE IS
OF POOR QUALITY



Figure 12
12

Keramikbauteile
ceramic components

/27

1. Allison C20 at MTU
license fabrication:
compressor

Allison C20 in MTU
Lizenzfertigung : 1
- Verdichter

2. MTU 7042
-rotor bearing
-spur gear drive
-controller, starter

MTU 7042 : 2
-Rotorlagerung
-Stirradgetriebe
-Regler, Starter

3. heat exchanger

Wärmetauscher 3

ORIGINAL PAGE IS
OF POOR QUALITY

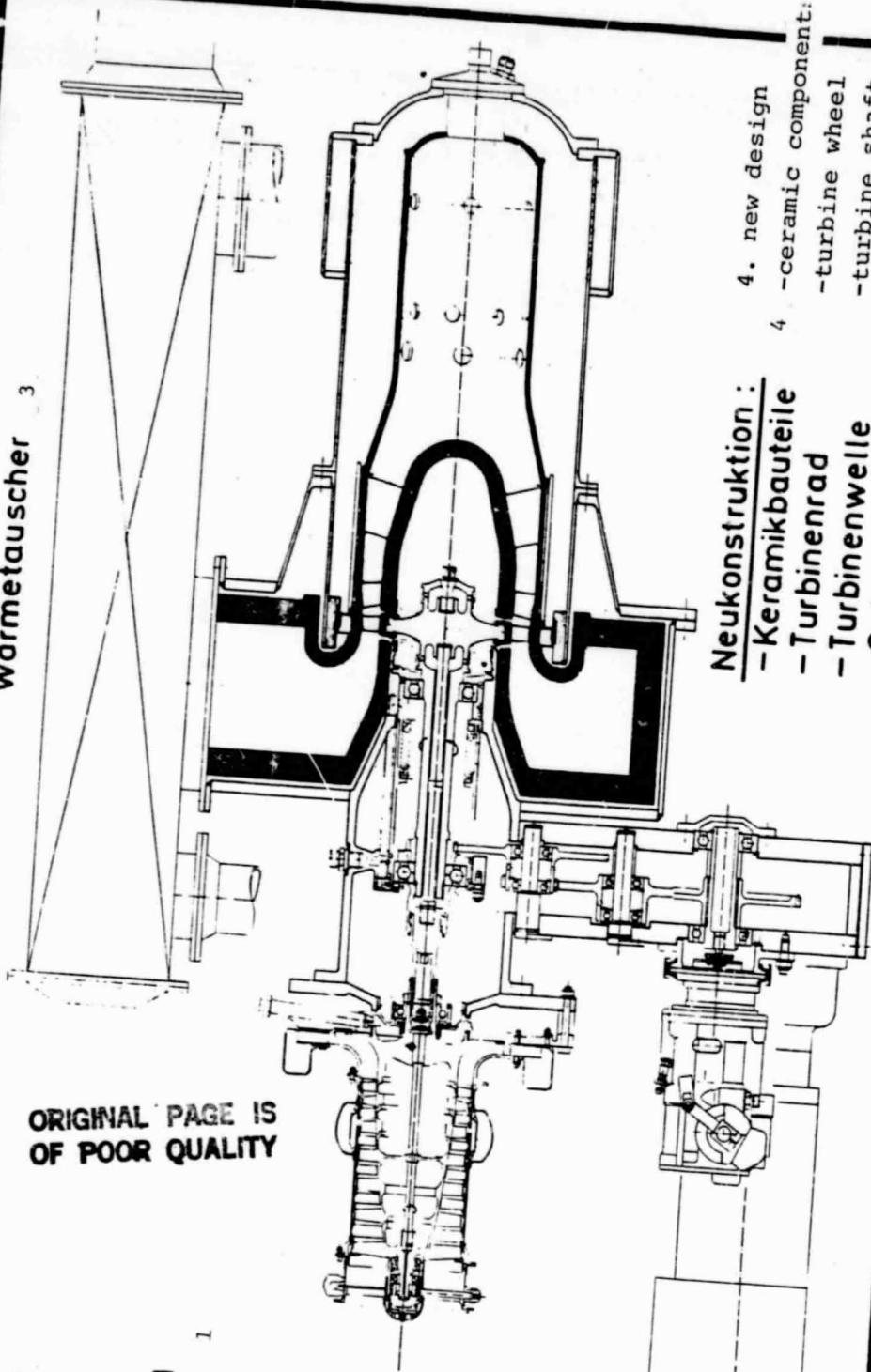

Neukonstruktion :
- Keramikbauteile
- Turbinenrad
- Turbinenwelle
- Gehäuse

4. new design
-ceramic component:
-turbine wheel
-turbine shaft
-housing

Versuchsträger

(Keramikbauteilerprobung)

5. test vehicle
(ceramic component testing)

Figure 13

13