

NASA Technical Memorandum 87636

(NASA-TM-87636) EARTH RADIATION BUDGET
EXPERIMENT (ERBE) SCANNER INSTRUMENT ANOMALY
INVESTIGATION (NASA) 87 P HC A05/MF A01
CSCL 131

N86-16592

Unclas
G3/35 05152

EARTH RADIATION BUDGET EXPERIMENT (ERBE)
SCANNER INSTRUMENT ANOMALY INVESTIGATION

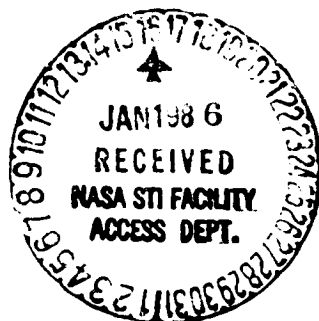

N. D. WATSON, J. B. MILLER, L. V. TAYLOR,
J. B. LOVELL, J. W. COX, J. C. FEDORS, L. P. KOPIA,
R. M. HOLLOWAY, AND O. H. BRADLEY

OCTOBER 1985

NASA

National Aeronautics and
Space Administration

Langley Research Center

Hampton, Virginia 22061

Table of Contents

	<u>PAGE</u>
o Executive Summary.....	1
o Introduction.....	3
o Description of Anomalies of ERBE Scanner..... Instruments on ERBS AND NOAA 9 Spacecraft	3
o Investigation Committee, Membership, and Charter.....	13
o Description and Operation of the ERBE Scanner Servo.....	13
o Investigation Approach.....	36
o Areas Investigated.....	36
- Test Data.....	36
Life Test Model (LTM)	
Engineering Model (EM)	
Flight Model (FM)	
- Procedures and Processes.....	37
ERBE Scanner Assembly	
Bearing Processing	
- Simulation, Analyses, and Systems Design Reviews.....	37
Simulation of the ERBE Scanner Anomaly.....	37
Thermal Analysis.....	42
ERBE Scanner Anomaly Electrical Design Review.....	42
Mechanical Design Review.....	43
o Analysis of ERBE Scanner LTM Ball Bearings Assembly by LeRC	65
Tribology Group	
o Conclusions.....	67
o Recommendations.....	68
o Appendix	
- "Analysis of Spacecraft Instrument Ball Bearings," by Wilfredo Morales, Williams R. Jones, Jr., and Donald H. Buckley of the NASA LeRC	

ERBE SCANNER ANOMALY INVESTIGATION

Executive Summary

The ERBE Scanner instruments were placed in Earth orbit on the ERBS S/C Bus on October 5, 1984, and on the NOAA-9 S/C Bus on December 12, 1984. On December 22, 1984, an anomaly was observed in the ERBS Scanner characterized by a sudden increase in several instrument temperatures and a sluggish operation of the elevation scan system. The anomaly persisted for a few days, disappeared and then reappeared with the cycle repeating. Initial studies by project personnel offered no single explanation for the anomaly. On March 18, 1985, the NOAA-9 Scanner developed a similar anomaly. A multi-disciplinary committee of LaRC personnel was formed in March 1985 to further investigate the anomalies. The results of the review indicate that the most probable cause of the anomalies is improper lubrication of the bearings. Science data has been relatively unaffected by the anomalies and continued operation of the instruments is recommended with no substantial operational changes. A similar lubrication problem exists with the unlaunched NOAA-G. However, the committee recommends proceeding with launch due to the risk, high cost and schedule impact of replacing the bearings. This memorandum summarizes the results of the investigation and recommendations. A more detailed analysis of the investigation is attached.

Anomaly Description

On December 22, 1984, as the ERBS Scanner was coming out of a full Sun orbit and all housekeeping temperatures were decreasing, the temperature of the scan drive electronics increased by 4 degrees centigrade over a period of 10 hours. The temperature increase coincided with a decrease in the average value of the angular position of the first Earth scan position and an increase in the standard deviation of the first position. The average value continued to degrade, with the standard deviation value increasing, until January 4, 1985, when the lowest average position value was reached. Scan performance then started to improve and by January 15, 1985, was back to near normal operation. The anomaly continued to appear and disappear in a random mode.

On March 18, 1985, the temperature of the NOAA-9 Scanner scan drive electronics rose from 42 to 47 degrees centigrade during an 8 hour period and resulted in the instrument being commanded off due to preset "red" limit procedure. As with ERBS, an analysis revealed that the value of the first Earth scan position had degraded in average value and standard deviation. The NOAA-9 Scanner was commanded back on and operation continued with that anomaly appearing and disappearing.

On May 1 and 2, 1985, the scan system on the ERBS Scanner became very erratic and would stick and then move slightly ahead and stick again. This operation lasted in both instances for several hours. Afterwards the operation returned to the, by now, "normal sluggish" operation. This "sticking" phenomenon re-occurred on July 3, 1985, but has not been observed since.

The erratic operation in May and July of the ERBS and the commanding off of the NOAA-9 due to "red" temperature limits resulted in a science data loss of less than 3 percent. The other instances of the ERBE and NOAA-9 sluggish scan operations have not caused any loss of science data and the "red" limits on NOAA-9 have been raised.

SUMMARY OF FINDINGS

The most probable cause of the observed anomalies in both Scanner instruments is the bearing lubrication system. It is the only mechanism that has been demonstrated through simulations and tests to be consistent with all observed anomalies and operations.

The probability is high that the scan drive electronics temperature rise associated with the anomaly is the result of continuously operating in the high power mode.

Testing and analysis has shown that the instruments can be operated in this high power mode without the temperatures increasing above the limits already observed and without overstressing the electronics or motor components.

Based on the limited experience with the current instruments, there is a good probability of a full mission success time of 1 year overlap of the ERBE and NOAA-9 data being achieved, since 7 months of data overlap already exist.

The same anomaly can reasonably be expected to occur on the NOAA-G Scanner when launched.

RECOMMENDATIONS

Continue with plans to launch the NOAA-G Scanner. It is not possible, within the schedule constraints to change the bearings. The risk, cost and time to changeout the bearings are major. The ERBS Scanner has already achieved nearly a years operation and the same could reasonably be expected for NOAA-G.

There is strong evidence that several other space programs have experienced anomalies from bearing lubrication problems. There is a relatively large data base on space lubrication and techniques which exists within NASA and industry. Unfortunately, there is no publication which combines this experience and knowledge for ready reference by system design engineers. It is recommended that the Agency generate a reference document for space bearing lubrication on flight programs.

o INTRODUCTION

o DESCRIPTION OF Anomalies of ERBE Scanner
Instruments on ERBS and NOAA-9 Spacecraft

Introduction

As a result of an anomaly that appeared as a sluggish and somewhat erratic operation during the scan of the ERBE Scanner Instrument on the ERBS Spacecraft, about 2 months after uncaging, the ERBE instrument team in December 1984, reviewed the data to identify the cause of the anomaly. Because very little diagnostic data was available, this early investigation on the ERBS anomaly did not positively identify the cause. When an almost identical problem appeared during the scan operation of the Scanner instrument on the NOAA-9 Spacecraft, also approximately 2 months after uncaging, the need for a better understanding of the cause and the potential implications became more critical, not only for the operations of the two scanners already in orbit but, also, for the NOAA-G ERBE instrument which is still in ground acceptance testing on the S/C Bus. In addition, it was thought that more information may be available as a result of this second anomaly in an almost identical instrument with a similar test history. As a result, a multidisciplinary team of LaRC personnel was formed in March 1985 to perform an in-depth investigation of all possible causes. This covered the scanner instrument operations, the mechanical, electrical, and electronics systems, and any possible related thermal effects. Since the initiation of this investigation, two additional reoccurrences of the anomaly, one on May 2 and one on July 3, 1985, have been experienced on the ERBS scanner and some variation in counts continue to be present in the NOAA-9 Scanner.

The body of this report will describe, in some detail, the basic approach and major details of the investigation and the basic conclusions and recommendations of the committee. For those interested in only an executive summary this is provided at the front of this report. The committee would like to extend a note of appreciation to other contributors to this effort from GSFC, Ball Aerospace Division, Barnes Engineering Company, and in particular the Tribology Group at LeRC who performed the disassembly and testing of the bearing assembly from the Life Test Model (LTM) of the Scanner.

Description of Anomalies of ERBE Scanner Instruments on ERBS AND NOAA-9 Spacecraft

The ERBE Scanner instrument is shown in figure 1 and an exploded view showing the major subsystems is shown in figure 2. Figure 3 gives a more detailed breakdown of the Scanner head assembly. A working drawing of the scanner head assembly is shown in figure 4.

The ERBE Scanner instruments are designed to collect Earth radiance data from Earth orbit using a programmed Earth scan profile illustrated in figure 5.

A space reference value is obtained at an elevation angle of 14° (encoder output of 1000 counts). A command to accelerate to a specified scan velocity ($66.7^\circ/\text{sec}$) is then given and velocity lock occurs at or near the elevation angle of 23° (encoder output of 1360 counts). Because of control circuit timing variability on the capture of velocity lock, the first Earth data sample nominally occurs as early as 22.5° (1340 counts) or as late as 23.5° (1380 counts). Radiometric samples are taken every $1/30$ second interval (elevation encoder intervals of 88-89 counts). The scan motor then accelerates to the internal calibration position after the scan across the Earth. The motor stops at 190° elevation (3944 counts) to obtain 4 data samples at the calibration position. Retrace to the space position occurs afterwards. The scan cycle then repeats continuously with a period of 4 seconds.

Control for the motor circuit issues from the slice 3 electronic boards, figure 6, housed in the scanner pedestal. The temperature of this assembly is monitored by a thermistor and nominally reads 38°C .

Variation in temperature of slice 3 is driven by the day/night variation of the satellite orbit and, in the case of ERBS orbit, precession affecting solar incidence angle on the instrument.

A total of four preprogrammed scan profiles may be selected by realtime or stored command. Selecting a specific scan profile (one of the four) requires a 16 second initialization period and directs the scan motor to drive clockwise and counterclockwise for specified times to achieve elevation information for the start of a new scan.

The ERBS was launched on October 5, 1984. The scan head was uncaged on October 23, 1984, and since that time has been collecting scan data. The contamination covers were opened on November 5, 1984, and Earth data collection began at that time. The normal Earth scan cycle has been interrupted on occasion to allow for solar calibrations, periodic spacecraft yaw maneuvers and full Sun orbit conditions which cause high heat input on the Scanner instrument.

On December 22, 1984, as the ERBS satellite was coming out of a period of a full/Sun orbital condition and all housekeeping temperatures were decreasing, the mean temperature of the slice 3 electronics suddenly rose from 40°C to 44°C over a 10 hour period. Data analysis revealed that the temperature rise coincided with a decrease in the angular position of the first Earth scan data point and an increase in the standard deviation of this first position. (This will be referred to as the "sluggish start" operation.) The value continued to degrade until January 4, 1985, when it reached a low of 1200 counts (19°). All sample intervals remained at 88-89 counts/interval during the linear portion of the scan but the samples at the internal calibration position exhibited overshoot and lack of position lock. The scan position gradually returned to near nominal operation by January 15, 1985, but the "sluggish start" anomaly has reoccurred intermittently.

Slice 3 temperature now varies as a function of day/night, orbit precession and motor drive requirements.

The NOAA-9 ERBE Scanner was launched on December 12, 1984. The uncaging of the scan head occurred on January 15, 1985, and it was placed in a normal Earth scan mode at that time. The contamination covers were deployed on January 31, 1985, for the collection of Earth data. Since NOAA-9 is in a Sun synchronous orbit all solar heating inputs to the instrument are very benign compared to ERBS. Scan operation changes only once every two weeks to complete a solar calibration.

On March 18, 1985, the temperature of the slice 3 electronics on the scanner on the NOAA-9 spacecraft rose from 42°C to 47°C during an 8 hour period. When the temperature of slice 3 reached 46°C, a red limit at that time, the scanner was placed in a standby mode per the NOAA Satellite Operations Control Center (SOCC) contingency plan. The temperature of slice 3 immediately decreased and continued to drop at a lesser rate until the instrument was turned back on. As with ERBS, data analysis revealed the scan position during the time before stow decreased in the count value of the first Earth scan data point.

The NOAA-9 scanner was powered up on March 19, 1985, with new limits on slice 3 temperatures resulting from an in-depth analysis of the ERBS experience.

The scan position continued to show the "sluggish start" syndrome driving the temperature of slice 3 to a level of 49°C.

Just after this second anomaly on the ERBE scanner on NOAA-9 the LaRC investigation team was formed. During the course of the investigation, other disruptions in the scans have been observed. They are described here for completeness of the data base at the time of this report.

On May 1, 1985, during the Solar Calibration sequence on the ERBS, it was observed that a problem developed during the scan mode change to a short scan. The encoder position showed no change in output value for nearly 7 minutes. In trying to initialize, the scan head evidently stuck in one position on its way toward a mechanical stop at the 0° position. Reversal of direction would have occurred automatically after reaching the mechanical stop but, since it never did, the head continued trying to drive to 0° while being stuck fast. Only when the next scan mode command was given, 7 minutes later, did the scan head break loose and drive in the opposite direction during scan initialization. All subsequent scans operated properly.

On May 2, 1985, a significant disruption of the scan occurred on ERBS. The scan became very erratic in its starting position and periodically would stick near the internal calibration position. The scan head would continue to move slightly and stick again. This situation resulted in an inability of the scan head to retrace properly, the loss of control sync, and consequently "walking" itself into a mechanical stop. Within 3 to 4 scan periods, however, the head would break loose and resynchronize and would operate in the "sluggish start" mode for approximately 10-20 scan periods.

The scanner operated in this mode of alternately skipping scans and proper operation for several hours. Afterwards the scan settled into an oscillation between the "sluggish start" mode and nominal scan mode without any obvious periodicity. The larger percentage of time was spent in the "sluggish start" mode. Slice 3 temperature stayed in the 45°C to 48°C region during this time.

On July 3, 1985, a repeat of the anomaly of May 2 occurred again on ERBS. The scan sticking/"sluggish start" scan oscillation described before was observed for approximately 13 hours. Afterwards the scan returned to its nominal pre-December 22, 1984, operation and has largely been that way to date. Occasionally the scan head fails to achieve full position lock at the internal calibration position (190° elevation) but that is only a small percentage of the total time. Slice 3 temperatures are near the 42°C to 45°C region.

On NOAA-9 the first Earth scan position varies between values of 1200 to 1320 counts, without any periodic behavior, with a rather stable slice 3 temperature of 49°C. The scan head continues to overshoot the internal calibration position and only occasionally achieves lock at 190°.

Other Observations

1. The time between uncage (scan initiation) and the 1st observation of the anomalous scan activity was 60 days for ERBS and 62 days for NOAA-9. The first significant scan problem occurred 191 days after uncage for ERBS and had not occurred for NOAA-9 (190 days since uncage, as of July 24, 1985).
2. Even though the ERBS Scanner suffered significant scan disruption on two occasions, the scan operation has recovered and is operating without significant deterioration. In every case the interval between data samples has continued to be between 88 and 89 counts consistently, verifying a linear scan, once moving, independent of starting point (except during severe sticking periods on May 1-2, and July 3).

ORIGINAL PAGE IS
OF POOR QUALITY

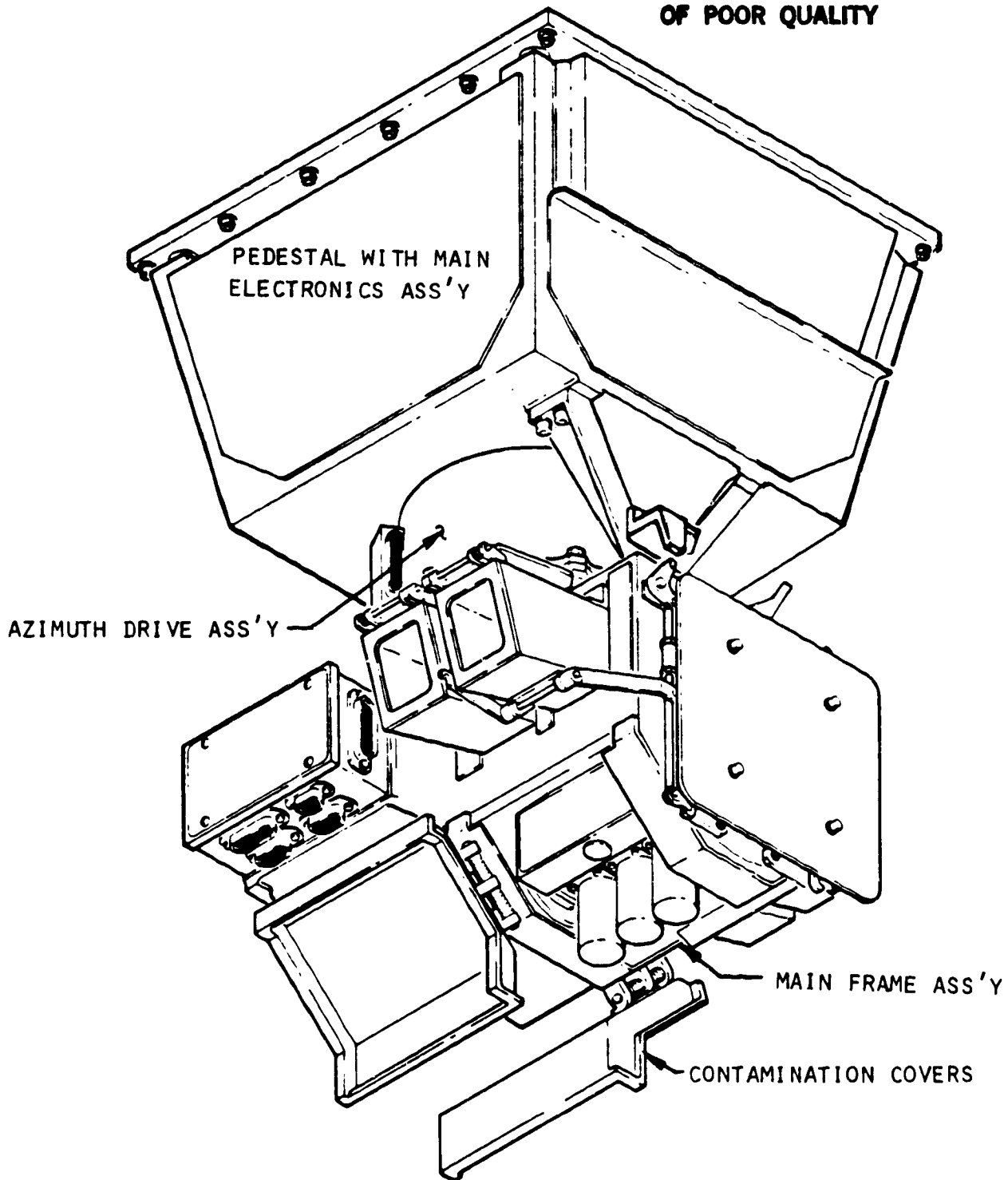

ERBE SCANNER INSTRUMENT

(SHOWN WITH CONTAMINATION COVERS DEPLOYED
AND THERMAL BLANKETS REMOVED)

Figure 1

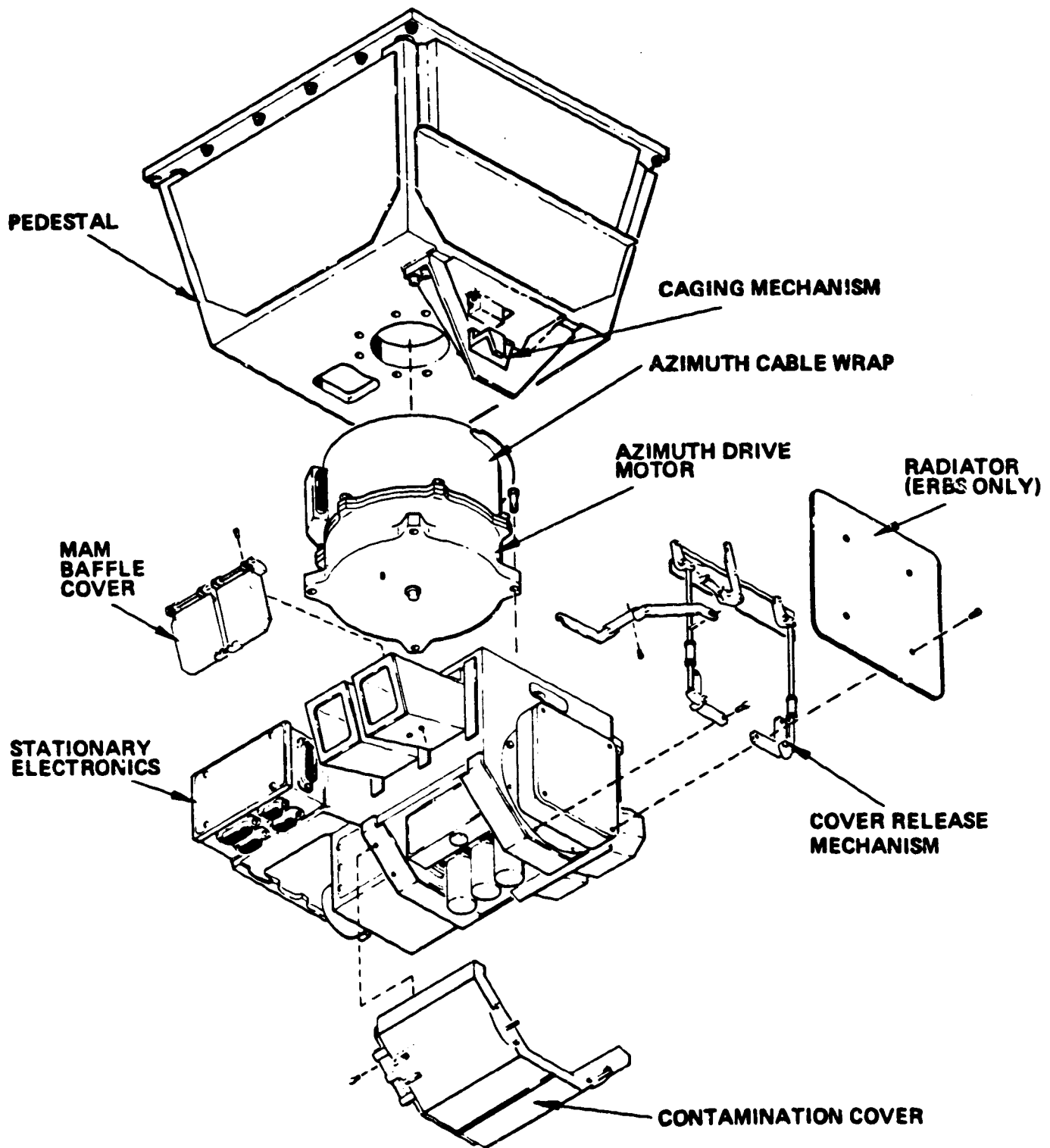

Scanner Exploded View

Figure 2

ORIGINAL PAGE IS
OF POOR QUALITY

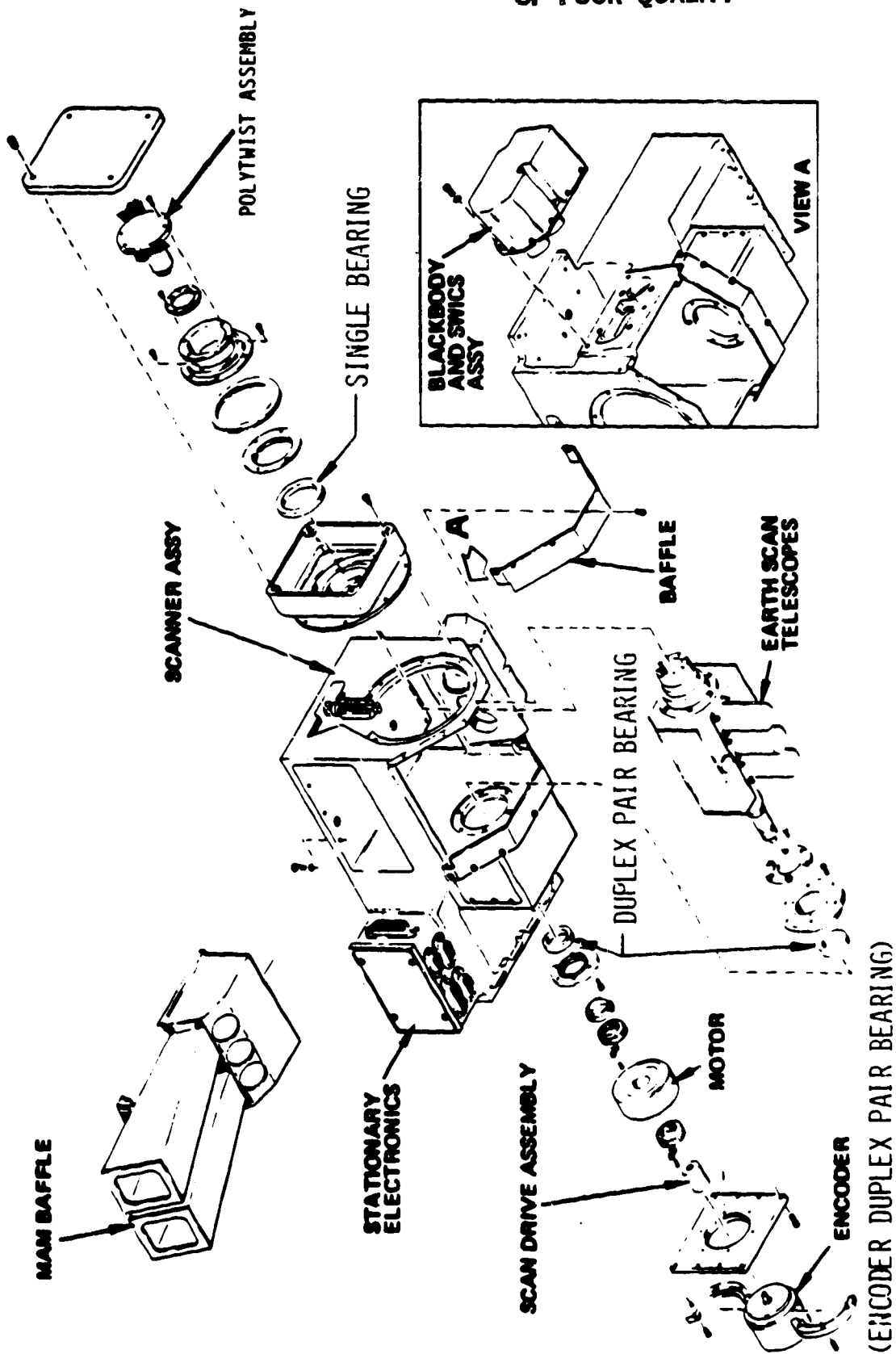

Scanner Head Assembly - Exploded View

Figure 3

ORIGINAL PAGE IS
OF POOR QUALITY

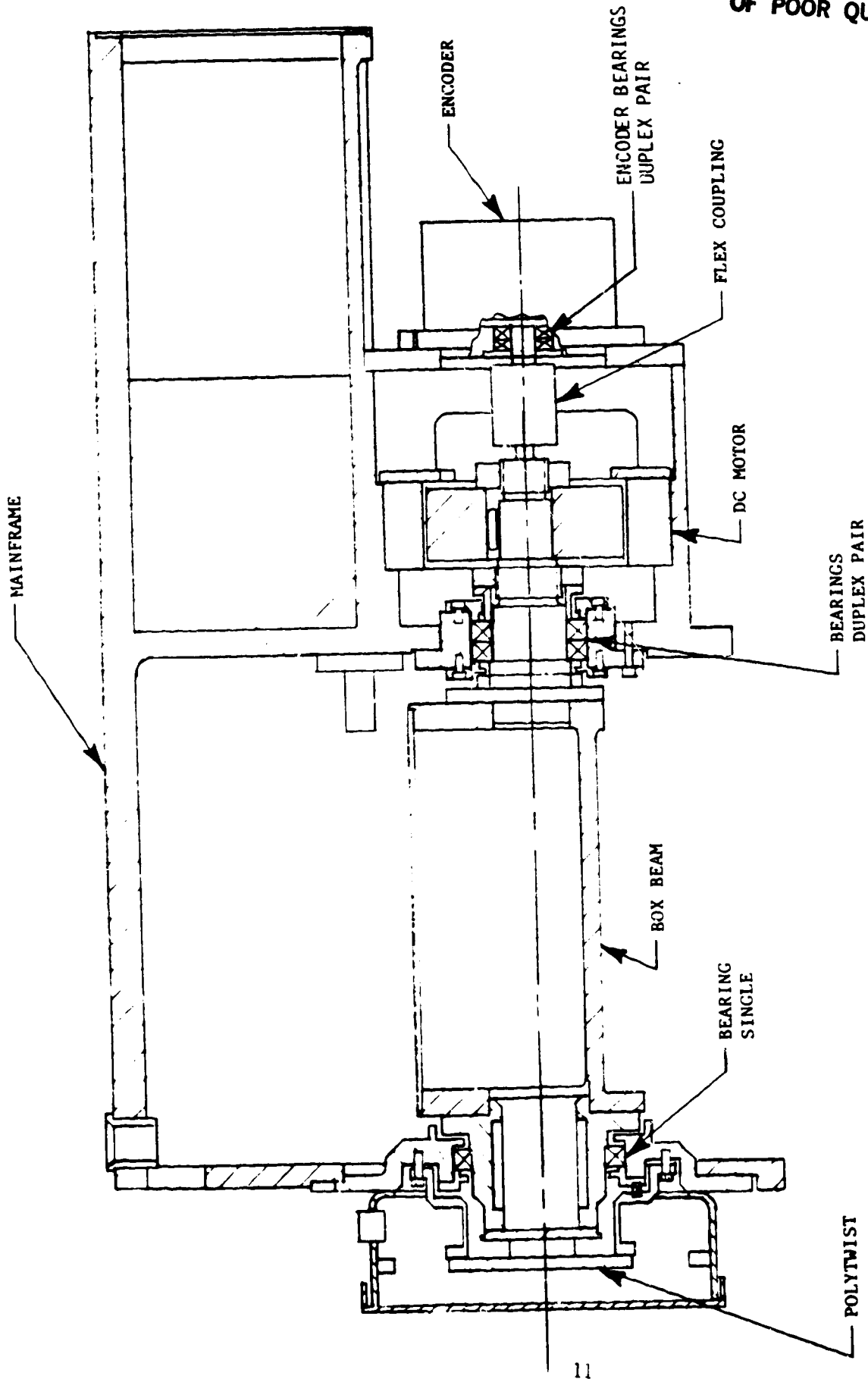

SCANNER HEAD ASSEMBLY

Figure 4

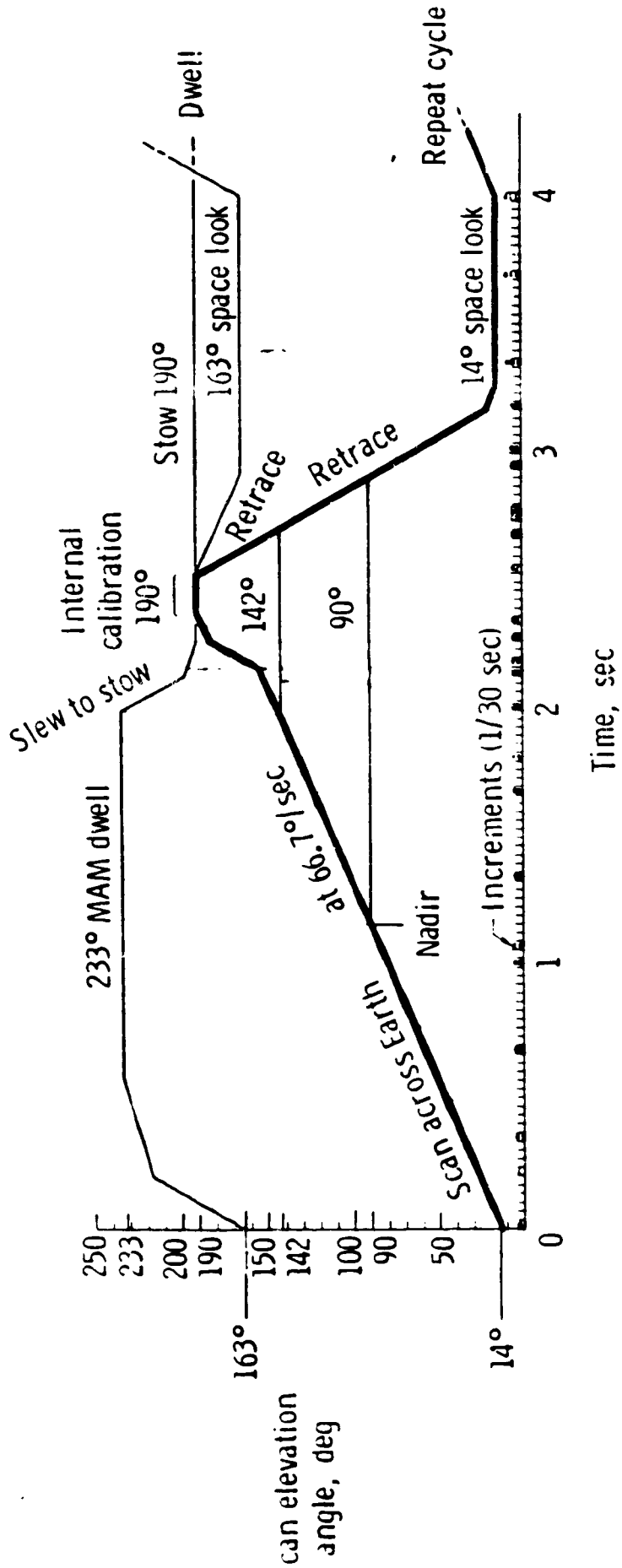

— NORMAL EARTH SCAN

FIGURE 5

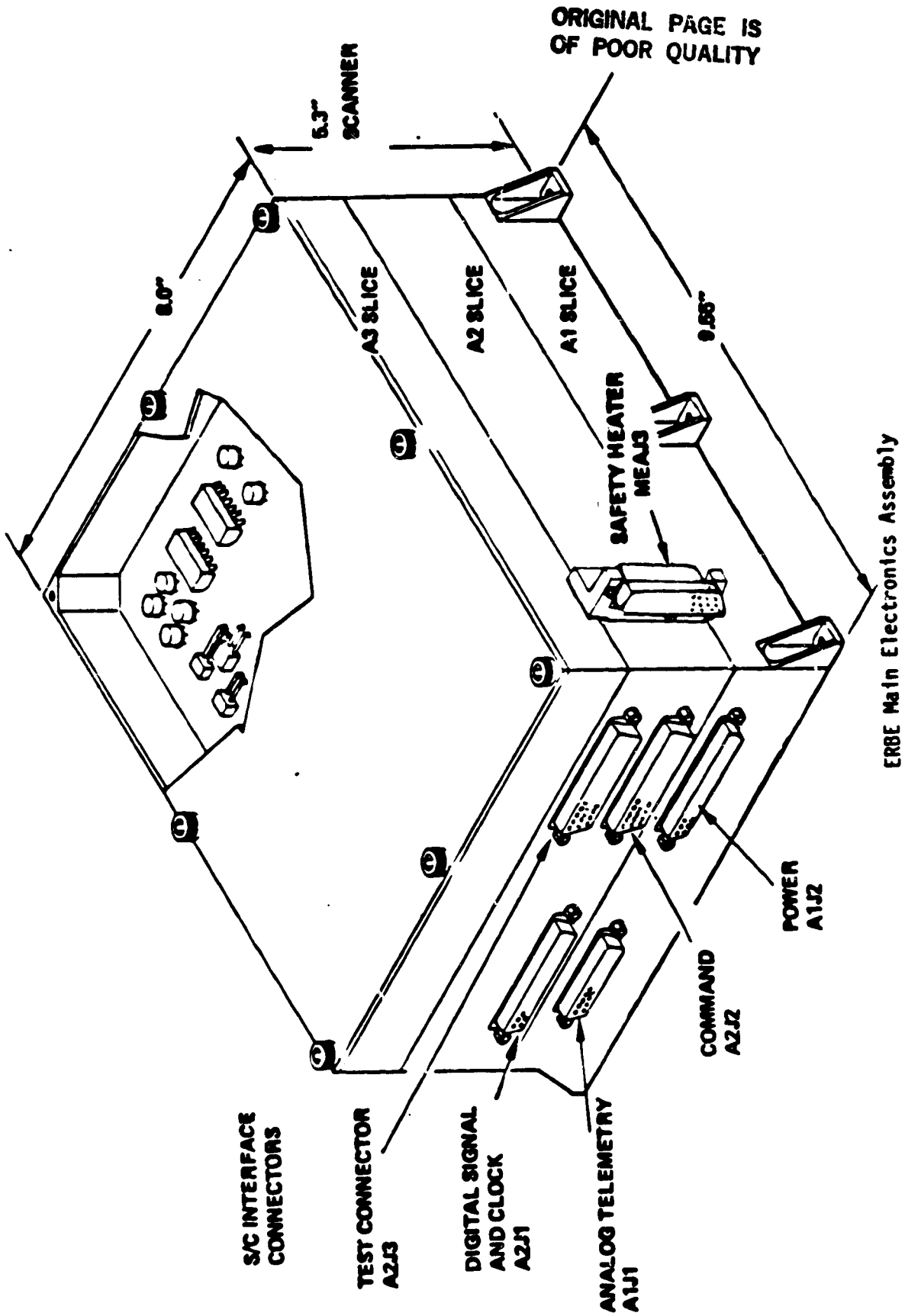

Figure 6

- o INVESTIGATION COMMITTEE, MEMBERSHIP, AND CHARTER

- o DESCRIPTION AND OPERATION OF THE ERBE SCANNER SERVO

Investigation Committee Membership and Charter

The ERBE Scanner Anomalies Investigation Committee membership is:

N. D. Watson	-	SED, Chairman
R. M. Holloway	-	FED
J. B. Miller	-	SED
L. V. Taylor	-	FED
J. B. Lovell	-	SED
J. W. Cox	-	SED
J. C. Fedors	-	FED
L. P. Kopia	-	FED

Also, Mr. Obie Bradley, SED, performed the thermal analysis on the NOAA-9 Scanner instrument in support of the investigation.

The committee had as its' charter to conduct an indepth investigation into the cause of the ERBE Scanner anomalies. It was further requested that the committee should call on whatever additional resources if felt would be beneficial to the investigation, including those within the Agency and industry. The findings of the committee were to be documented in a written report and a final oral presentation was also requested.

Description and Operation of the ERBE Scanner Servo

Description of the Scanner Servo

The ERBE Scanner Servo consists of a single axis rotating detector assembly driven by a brushless dc torque motor with position sensing provided by an incremental encoder. There are two basic functional modes, Position and Velocity, into which the scanner servo can be commanded, and a third transient Boost Mode which is initiated by each mode command. A simplified block diagram of the system is given in figure 1.

The output of the encoder provides feedback for both the position and velocity control loops, and provides a separate set of signals to the driver for motor commutation. In Velocity Mode a phase lock loop compares the output from one quadrature output of the encoder (3600 counts/revolution) with the selected reference square wave. The phase lock loop output is used to determine the end of Boost Mode, and is filtered to produce the velocity error voltage. In Position Mode the two outputs of the encoder are combined to produce a "times 4" output which is accumulated in the 14 bit position counter. The output of the position counter is algebraically summed with the selected position set-point value to generate the position error which is applied to the digital to analog converter to produce the position error voltage. Mode selection is accomplished by connecting the appropriate error signal to the drive electronics via a series of analog switches. The remaining servo electronics are common to both modes, and consist of a second order low pass filter, a switched integrator, a lead-lag compensator and a motor current driver.

Boost Mode is a temporary open loop condition which is invoked for at least 2.5 ms after the microprocessor issues a Velocity Mode command. In Boost Mode the input to the normal control circuits is grounded and the full drive current (200 ma) of the desired polarity is applied to the motor. Boost is terminated when the 2.5 ms delay has elapsed and the phase lock loop output has switched polarity (i.e., $| \text{actual velocity} | > | \text{desired velocity} |$ for acceleration, and $| \text{actual velocity} | < | \text{desired velocity} |$ for deceleration). The actual switching point varies as a function of the random initial phase relationship between the reference and encoder waveforms as well as all other parameters which affect servo dynamics. Figure 2 illustrates that during acceleration the phase lock loop requires the frequency of ENC (scanner velocity) to exceed the reference frequency (REF) before it switches polarity and terminates Boost Mode. During Boost, the integrator in the compensation circuit is also shorted by an analog switch.

The two torque motor windings are driven by a dual "H" bridge Pulse Width Modulated (PWM) driver operating at approximately 1 KHz. The driver operates at two regulated current levels as selected by the control electronics. These currents are 200 ma. and 66.7 ma. per winding, and are referred to as the high and low current levels respectively. When high current is selected the error voltage to the driver is divided by 3 to maintain a constant system gain. The driver is locked into high current mode during Boost Mode operations and whenever the servo error signal is greater than approximately 1.8 volts.

Scanner Servo Commands

Commands are issued to the scanner servo by the Scanner Microprocessor in the Main Electronics Assembly pedestal. Commands are issued in a time sequence as a function of the desired operation and the master clock. Because they are issued as a time sequence, they are related to the expected state, not the actual state, of the instrument. A Velocity Mode command consists of loading the rate generator register with the bits which determine the desired reference frequency, setting the direction and boost bits, and selecting the velocity error signal.

Position Mode commands consist of loading the desired position register and issuing a velocity command at 66.7 °/S with the Position Mode enable bit set. The direction of the velocity command is preprogrammed based on the desired position and the expected scanner position at the time it is issued. When the position of the head is within +0.06 deg. of the desired position the scanner switches to Position Mode and selects the position error signal.

Scan Sequences

A normal scan consists of a timed sequence of Position and Velocity Mode commands issued by the instrument microprocessor (Table 1). Plots of the nominal position, velocity, and torque profiles for a normal scan are given in figures 3 thru 5.

There are four additional scan command sequences which can be issued to the scanner servo. These are used during solar calibration and for periods of high beta angle. These sequences are Short Scan, Nadir Scan, MAM Scan, and Scan to Stow. Command sequences to produce these scans and plots of the resulting position, velocity and torque profiles are given in Tables 2 thru 5 and figures 6 thru 17 respectively.

Beside these scan profiles, there are two initialization sequences which are executed following instrument turn-on and each time the scan profile is changed. Initialization is required for two reasons: (1) the encoder is an incremental device which must be scanned through a "Zero" pulse position (90°) to initialize the position counters to the correct position count and (2) each of the scan sequences assumes that the scan head is located at the appropriate space look position at the start of a scan. During initialization, the scan head alternately drives clockwise (increasing angle) and counter-clockwise from stop to stop in 4 second intervals lasting 16 seconds. The last step in the initialization sequences is to command the scan head to the appropriate space position (14° or 163°).

COMMAND	TIME	TYPE	VEL deg/sec	DIR	POS deg
Acceleration to Scan	0.000	velocity	66.7	+	*
Acceleration to Patch	2.167	velocity	266.7	+	*
Patch Position	2.267	position	66.7	+	190
Accelerate to Retrace	2.533	velocity	266.7	-	*
Space Position	3.167	position	66.7	-	14

ERBE Scanner Normal Scan Command Sequence

Table 1.

COMMAND	TIME	TYPE	VEL deg/sec	DIR	POS deg
Acceleration to Scan	0.000	velocity	66.7	+	*
142o Position	1.800	position	66.7	+	142
Acceleration to Retrace	2.733	velocity	266.7	-	*
Space Position	3.167	position	66.7	-	14

ERBE Scanner Short Scan Command Sequence

Table 2.

COMMAND	TIME	TYPE	VEL deg/sec	DIR	POS deg
Acceleration to Scan	0.000	velocity	66.7	+	*
Nadir Position	1.067	position	66.7	+	90
Accelerate to Retrace	2.933	velocity	266.7	-	*
Space Position	3.167	position	66.7	-	14

ERBE Scanner Nadir Scan Command Sequence

Table 3.

COMMAND	TIME	TYPE	VEL deg/sec	DIR	POS deg
Acceleration to MAM	0.000	velocity	266.7	+	*
MAM Position	0.233	position	66.7	+	233
Acceleration to Patch	2.000	velocity	266.7	-	*
Patch Position	2.133	position	66.7	-	190
Acceleration to Alt. Space	2.533	velocity	66.7	-	*
Alt. Space Position	2.767	position	66.7	-	163

ERBE Scanner MAM Scan Command Sequence

Table 4.

COMMAND	TIME	TYPE	VEL deg/sec	DIR	POS deg
Acceleration to Scan	0.000	velocity	66.7	+	*
Acceleration to Patch	2.067	velocity	266.7	+	*
Patch Position	2.267	position	66.7	+	190

ERBE Scanner Scan to Stow Command Sequence

Table 5.

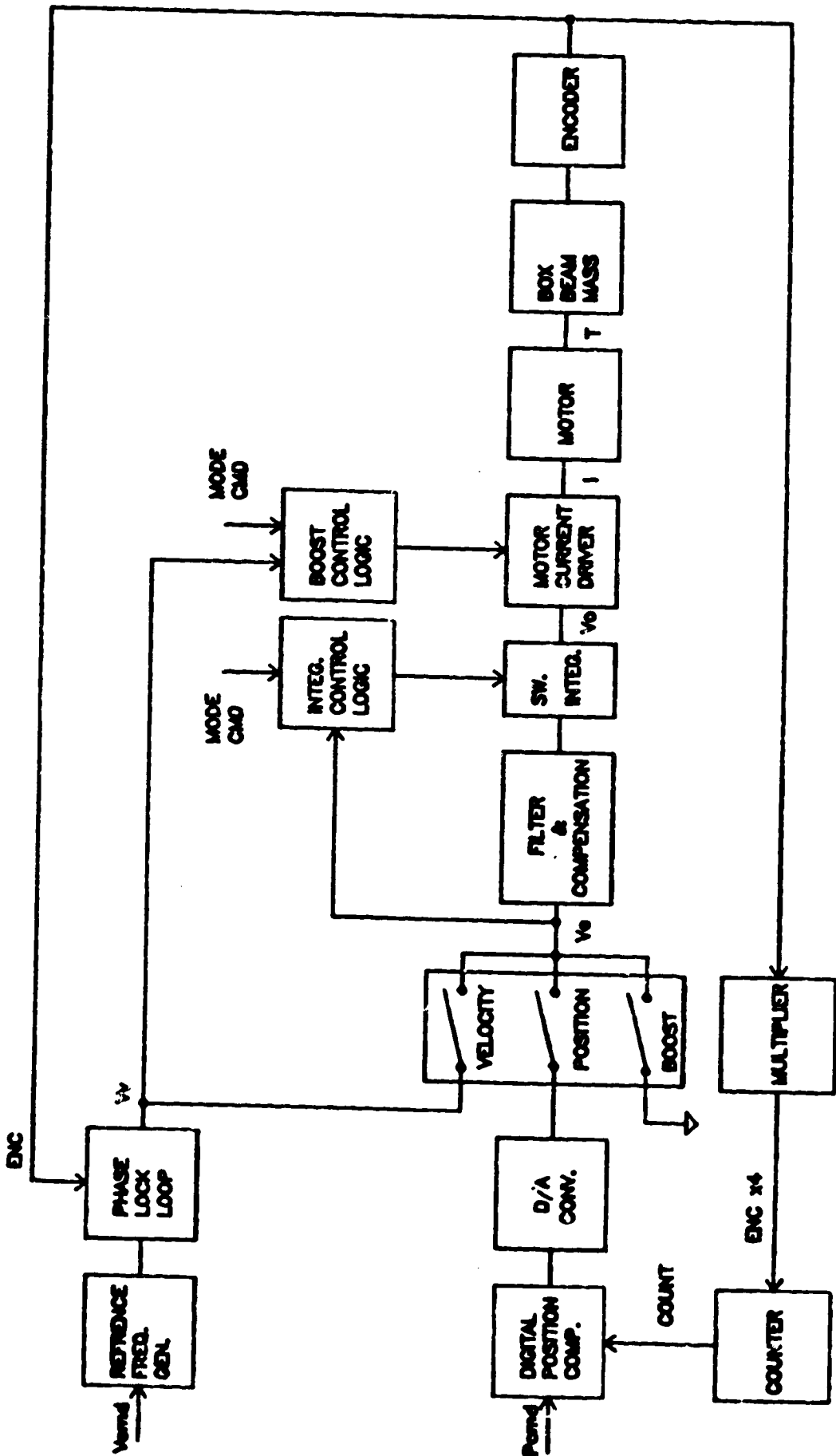
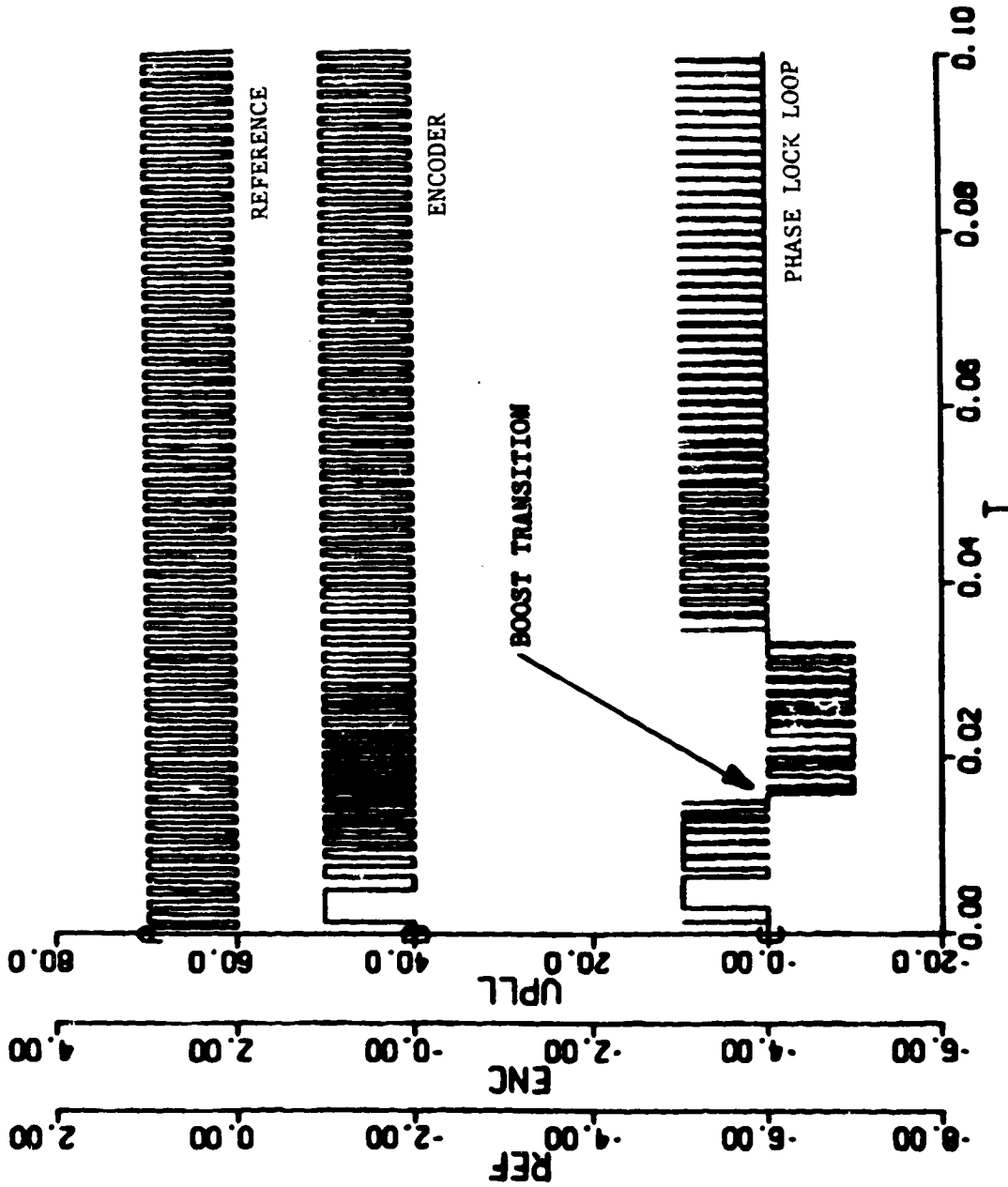

FIGURE 1.
ERBE Scanner Servo Simplified Block Diagram

ORIGINAL PAGE IS
OF POOR QUALITY



KRM Scanner Acceleration to Scan

Figure 2

ERBE SCANNER (Model 3.2)

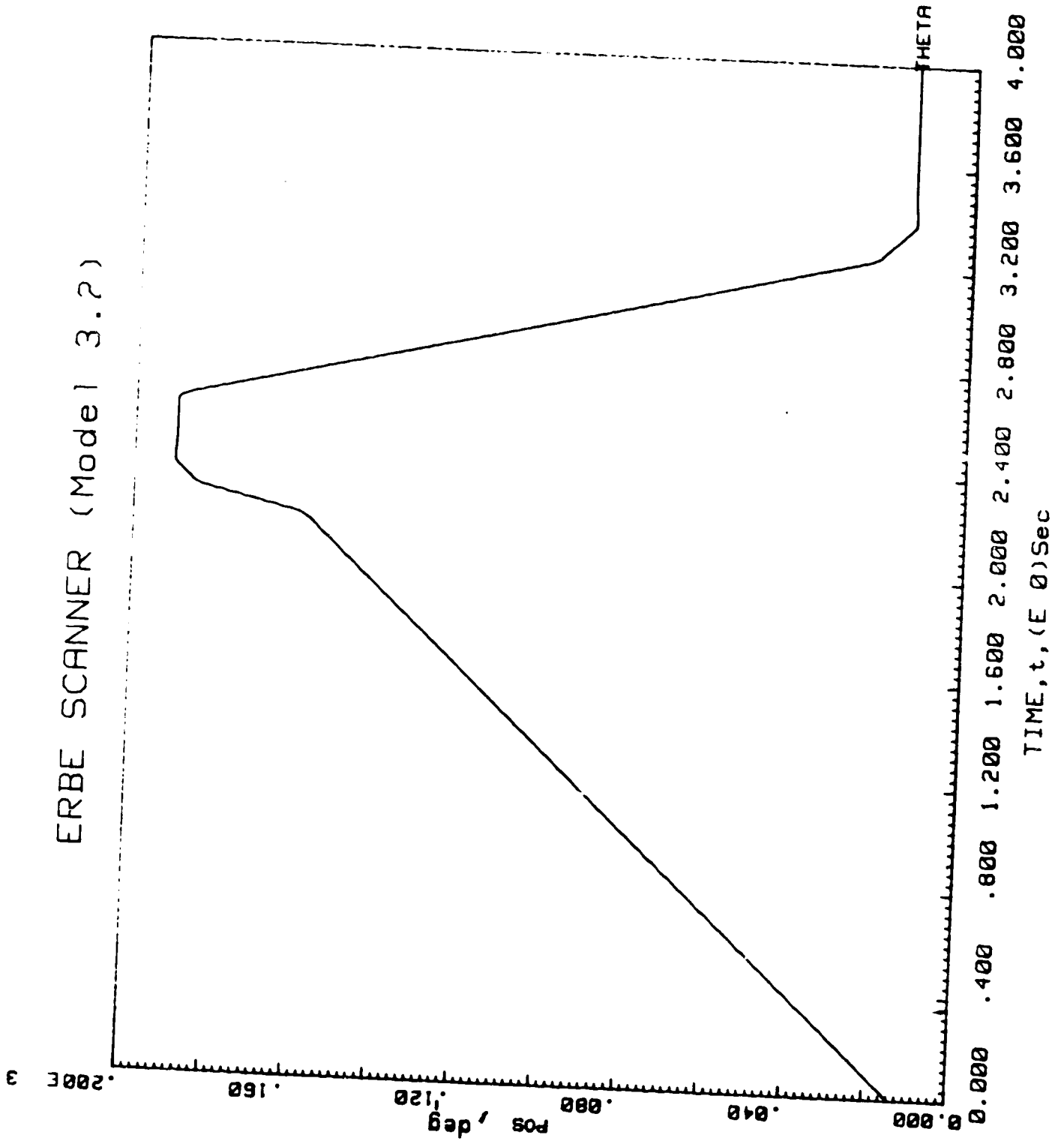

ERBE Scanner Normal Scan (Position) Figure 3

ERBE SCANNER (Mode 1 3.2)

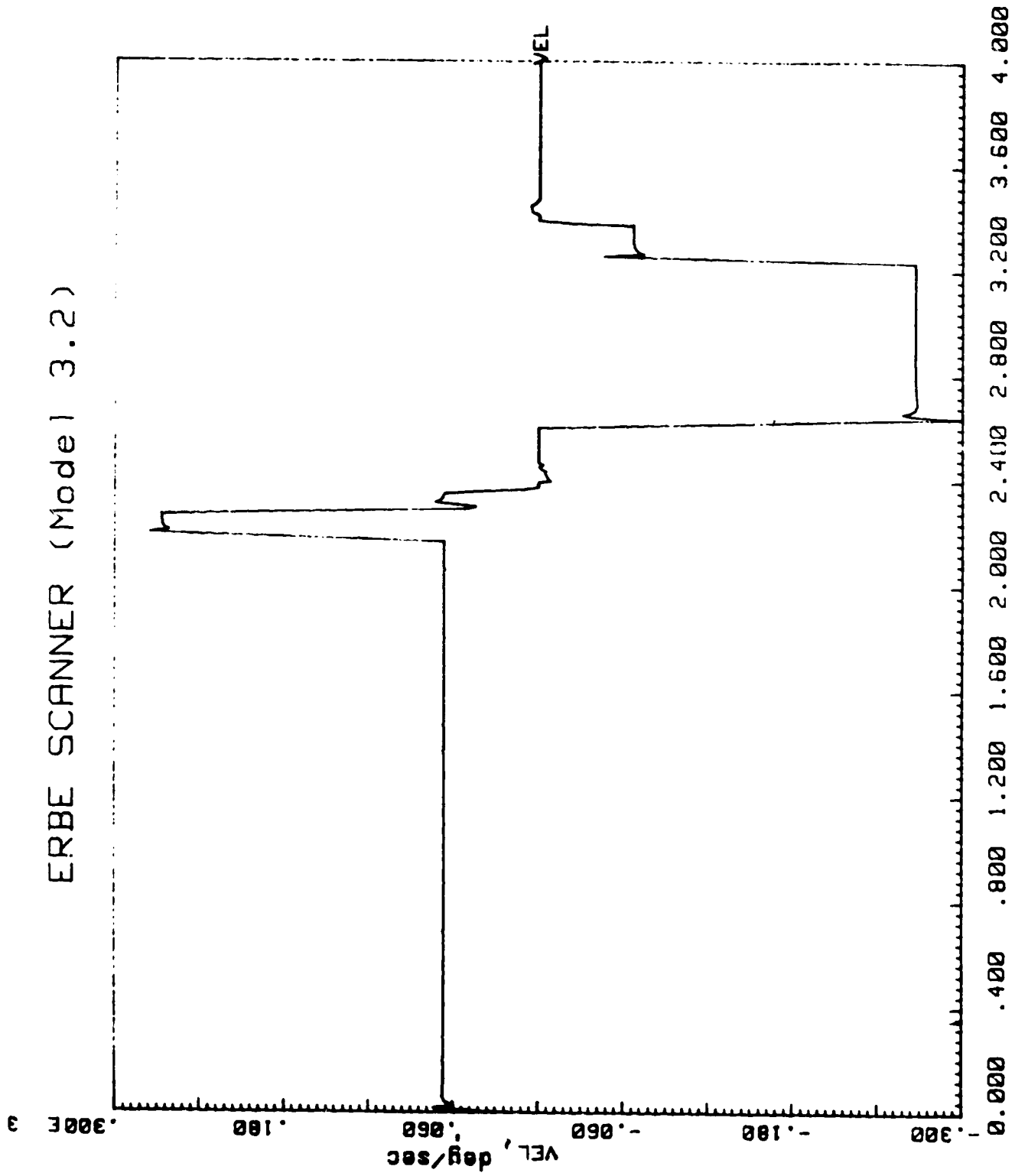

TIME, t, (E 0)Sec

ERBE Scanner Normal Scan (Velocity) Figure 4

ERBE SCANNER (Model 3.2)

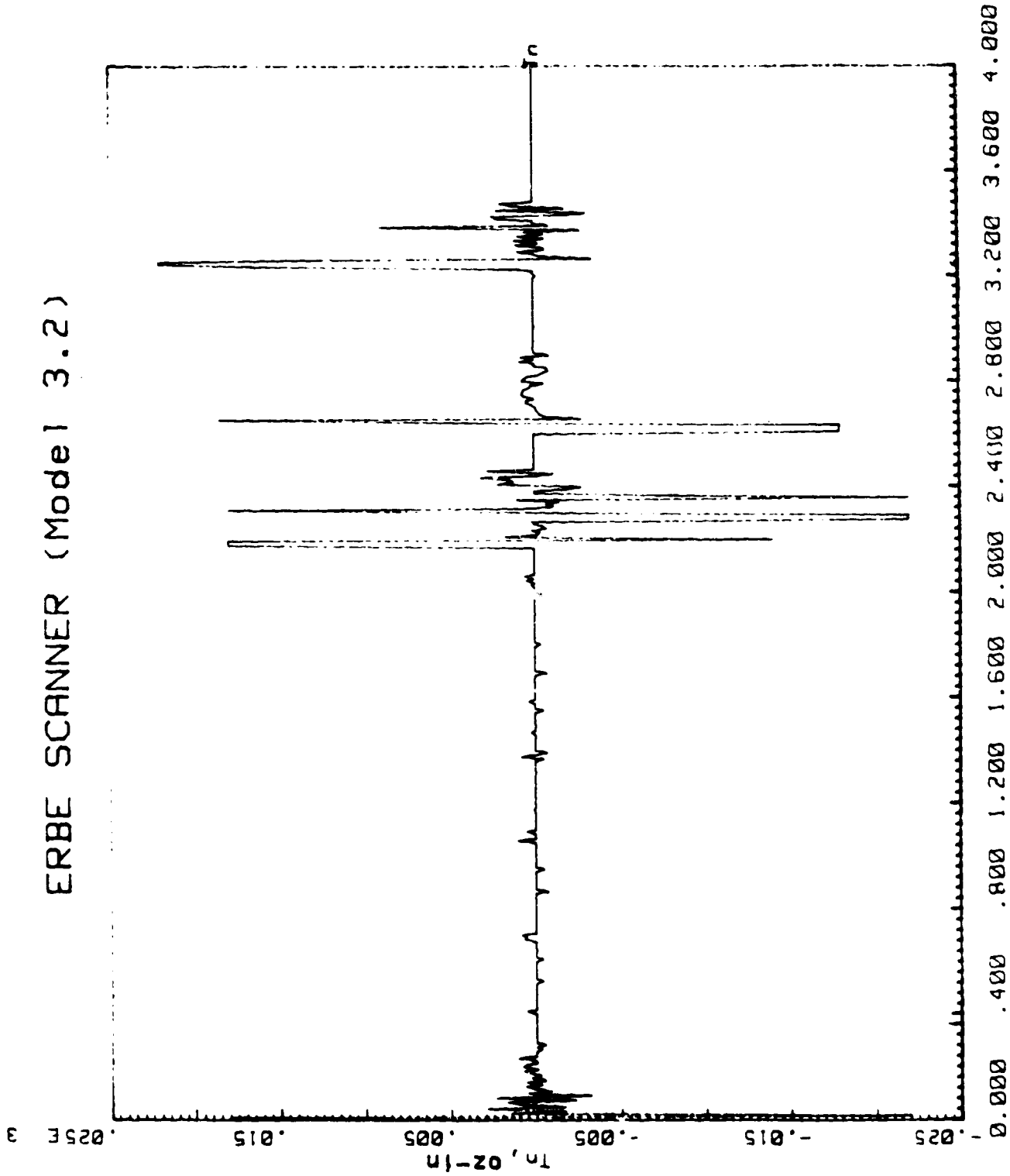

TIME, t, (E 0)Sec

ERBE Scanner Normal Scan (Net Torque) Figure 5

ERBE EM SCANNER
SHORT SCAN

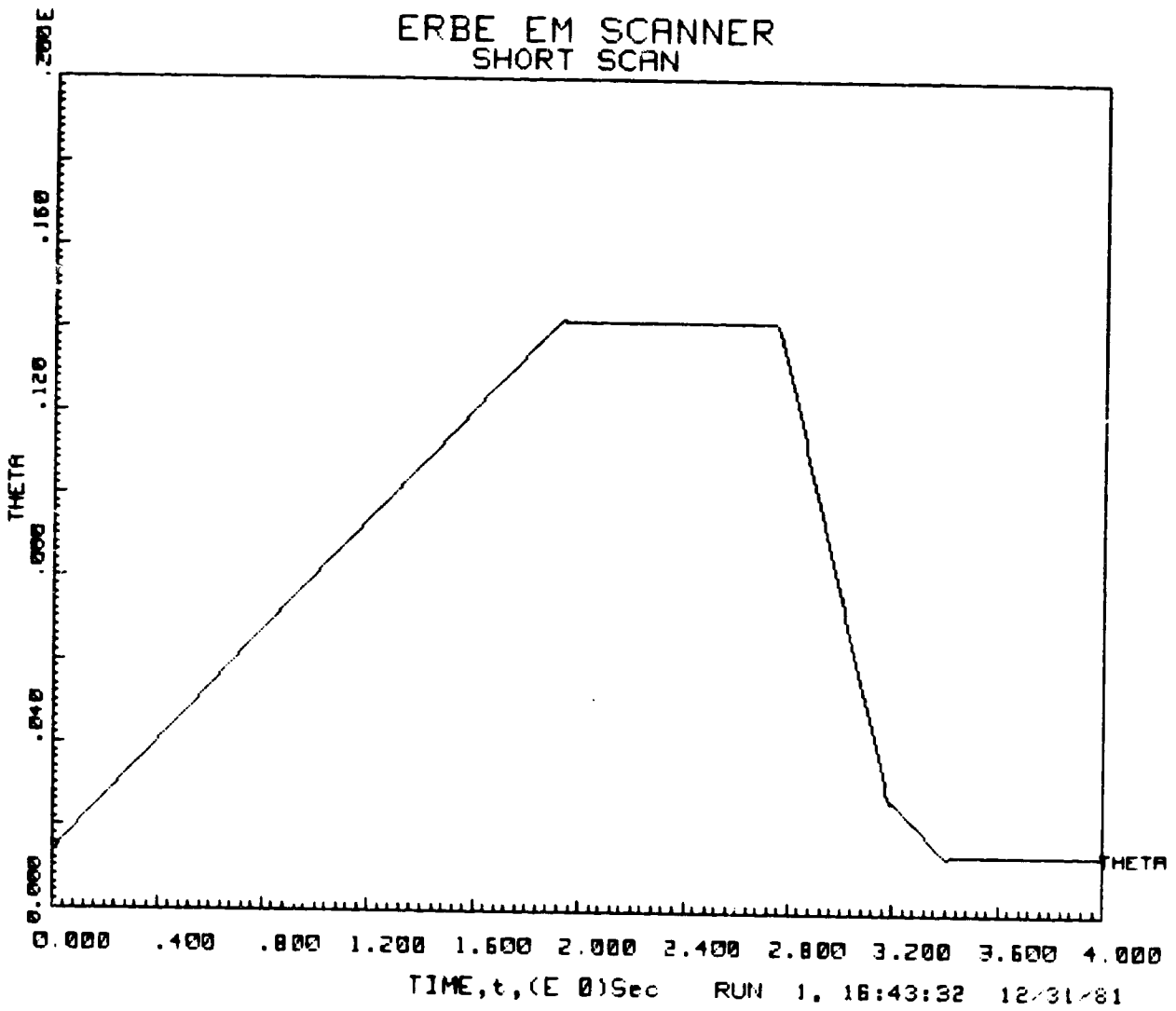

SHORT SCAN POSITION FIGURE 6

ERBE EM SCANNER
SHORT SCAN

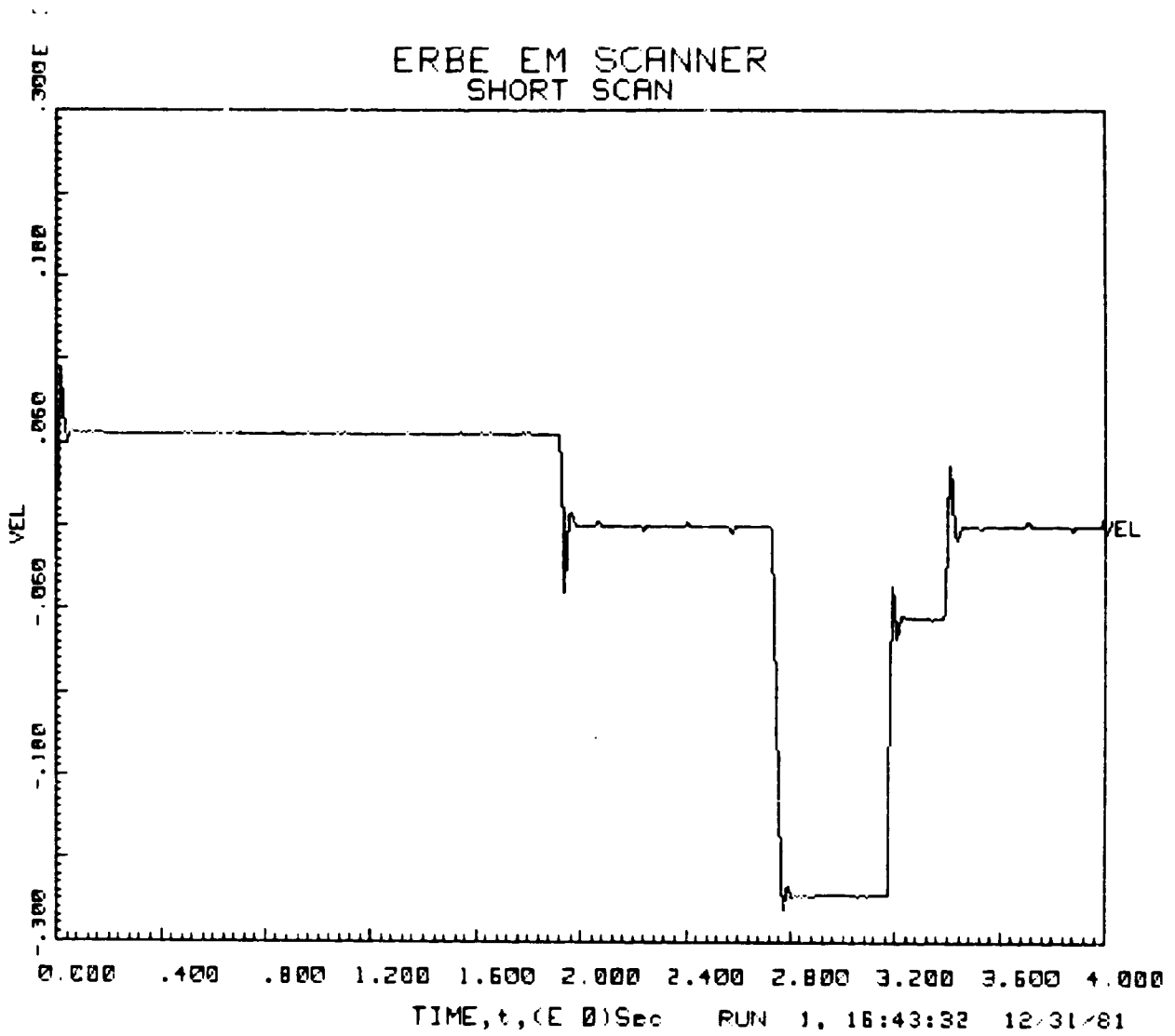

SHORT SCAN VELOCITY FIGURE 7

ERBE EM SCANNER
SHORT SCAN

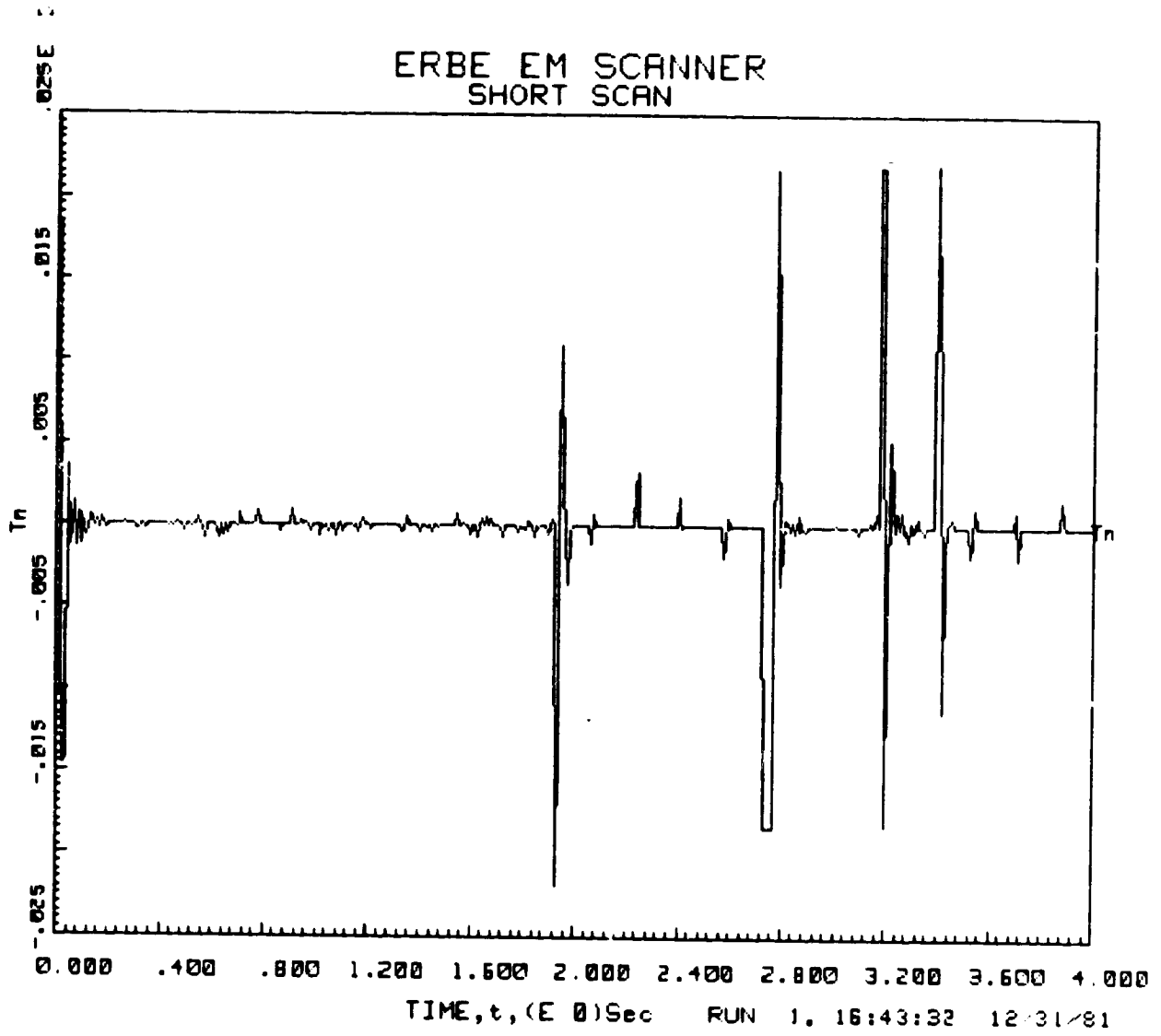

SHORT SCAN NET TORQUE FIGURE 8

ERBE EM SCANNER
NADIR SCAN

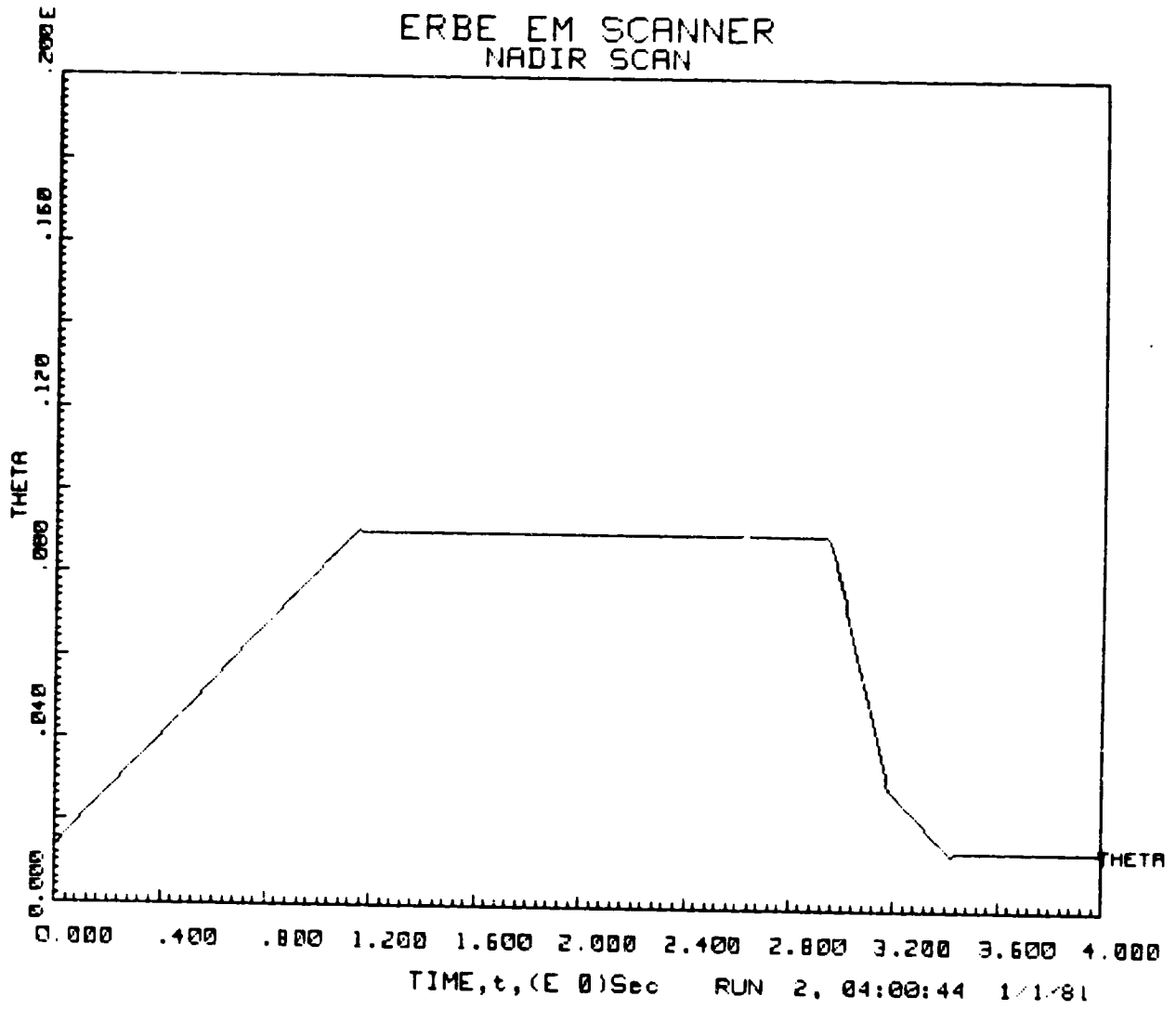

NADIR SCAN POSITION FIGURE 9

ERBE EM SCANNER
NADIR SCAN

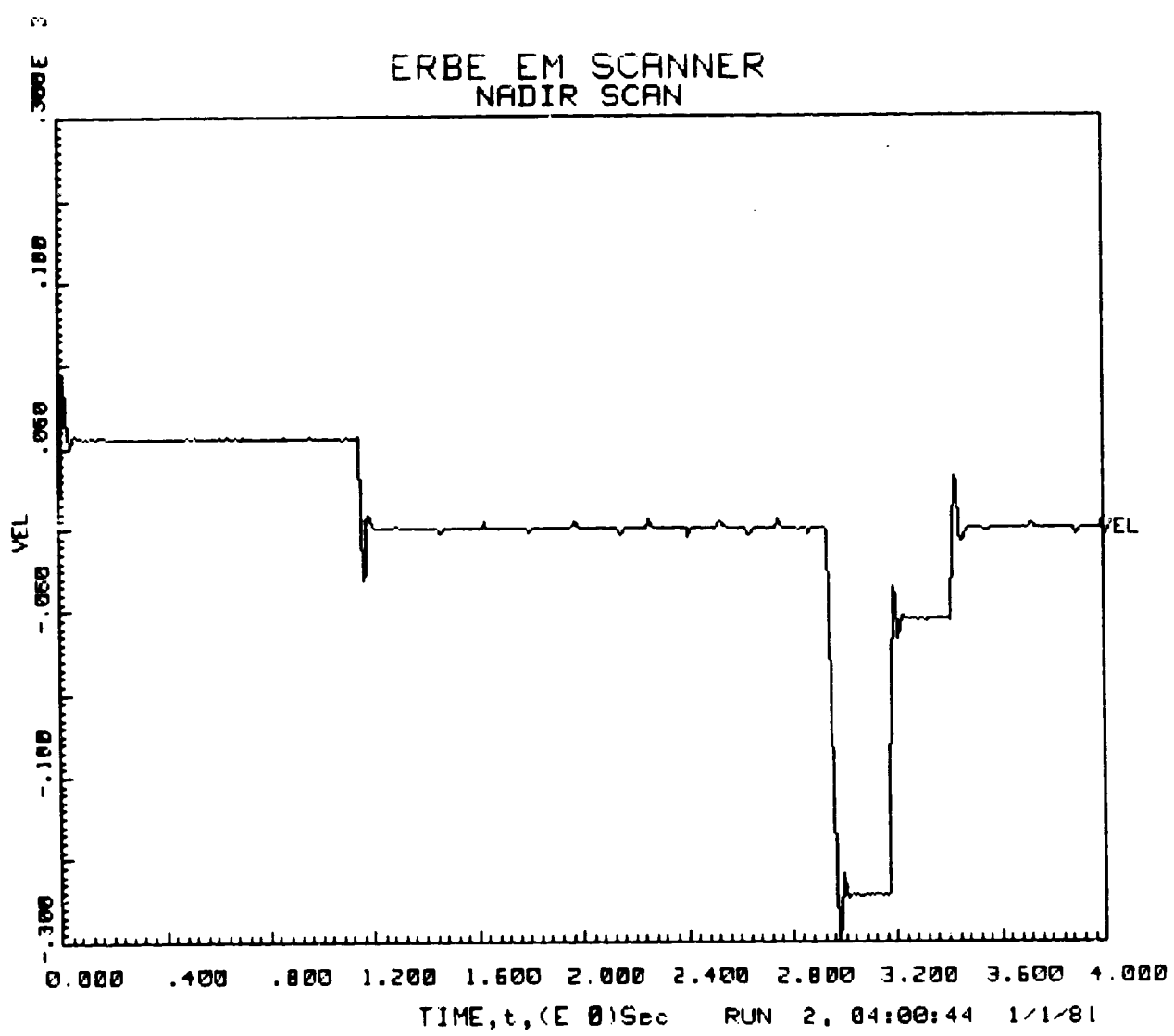

NADIR SCAN VELOCITY FIGURE 10

ERBE EM SCANNER
NADIR SCAN

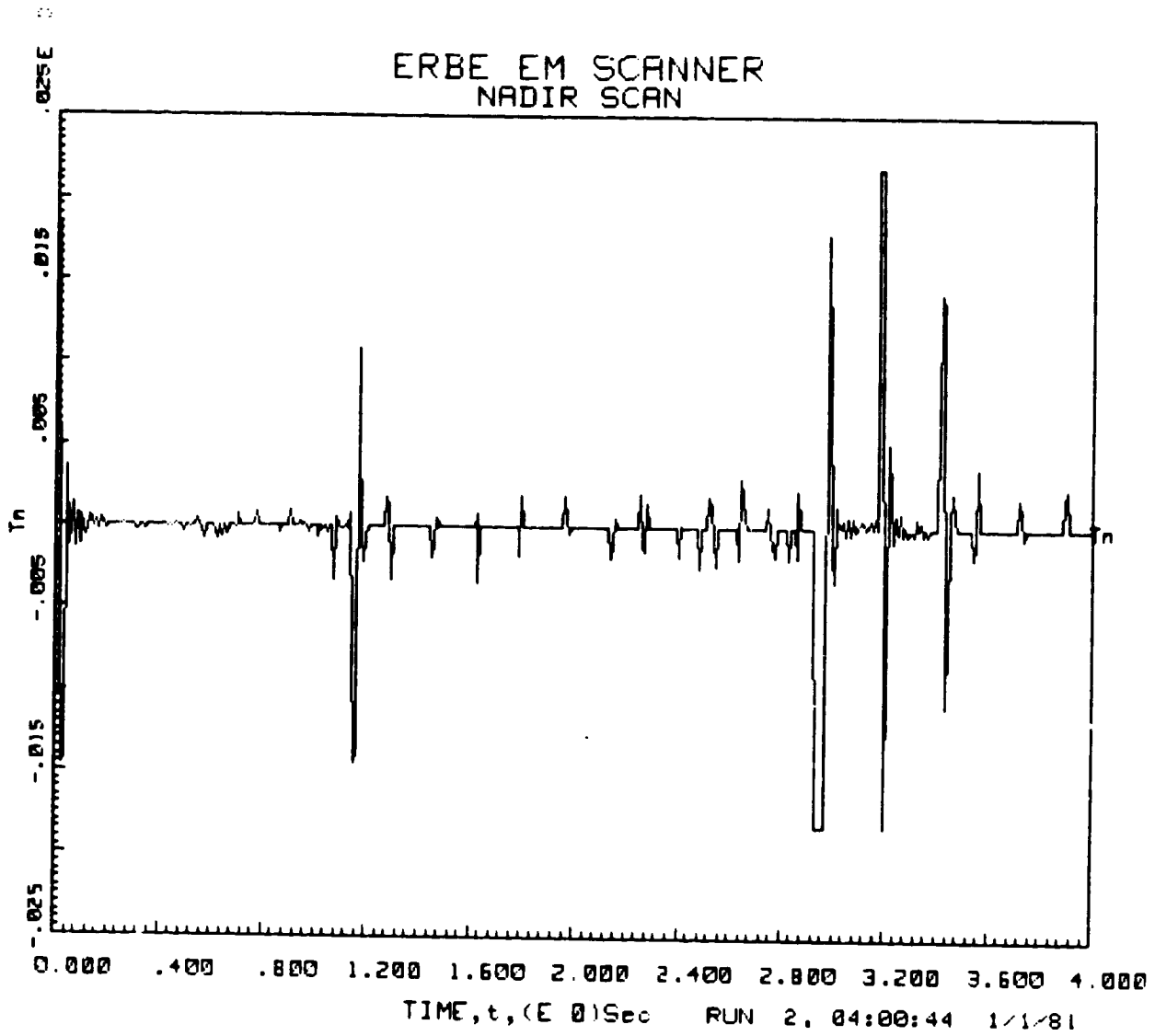

NADIR SCAN NET TORQUE FIGURE 11

ERBE EM SCANNER
MAM TO SPACE

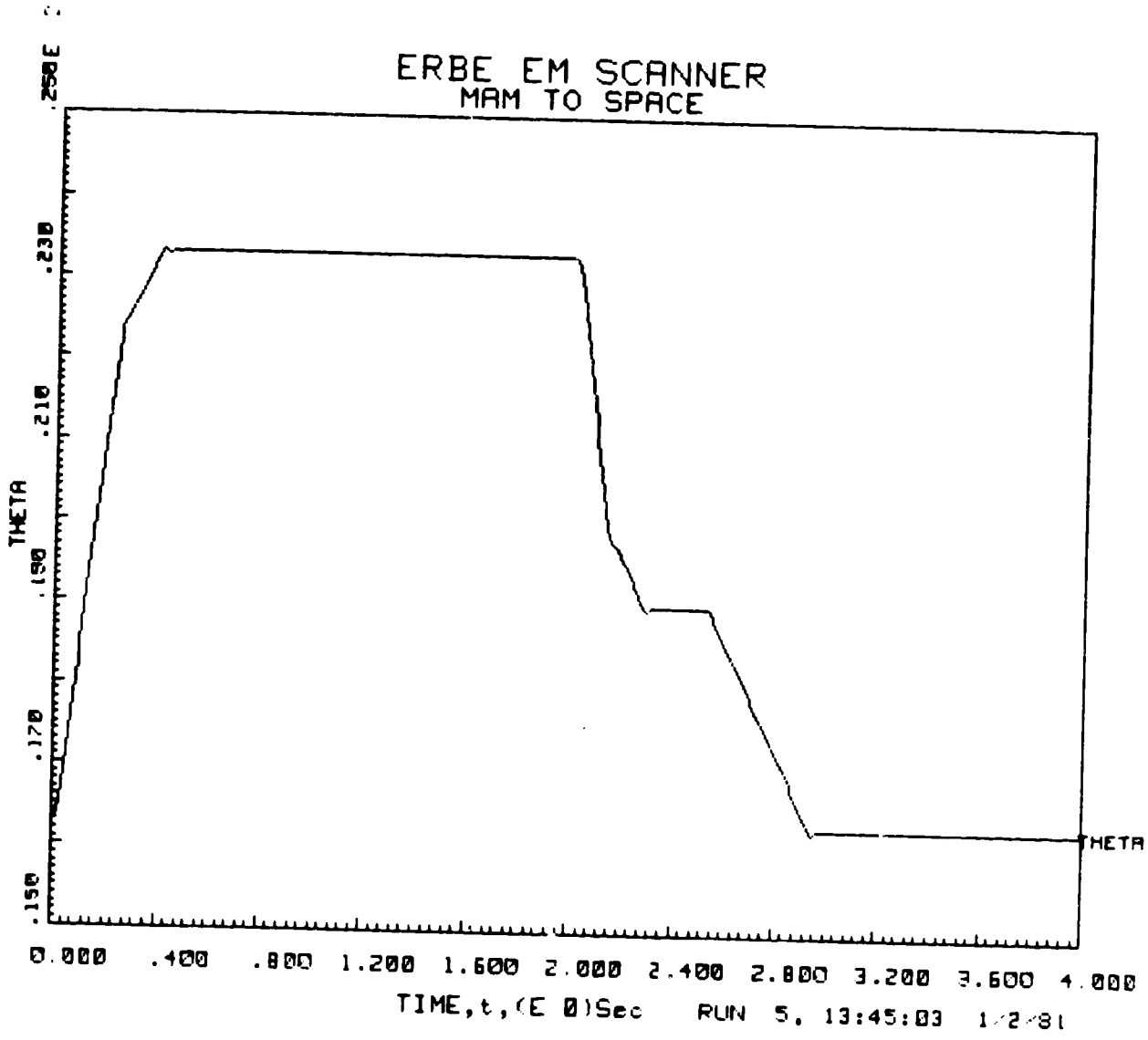

MAM SCAN POSITION FIGURE 12

ERBE EM SCANNER
MAM TO SPACE

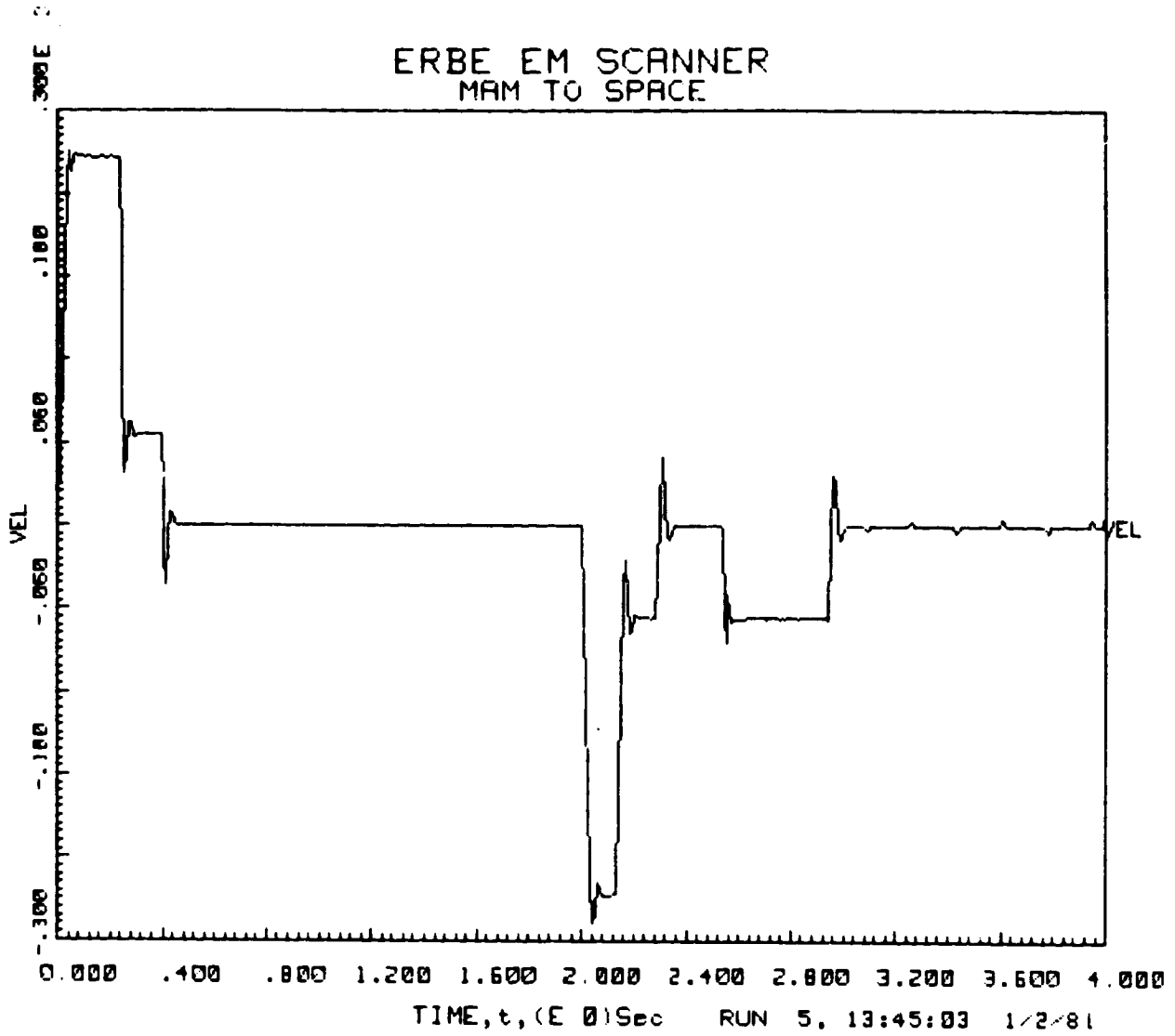

MAM SCAN VELOCITY FIGURE 13

ERBE EM SCANNER
MAM TO SPACE

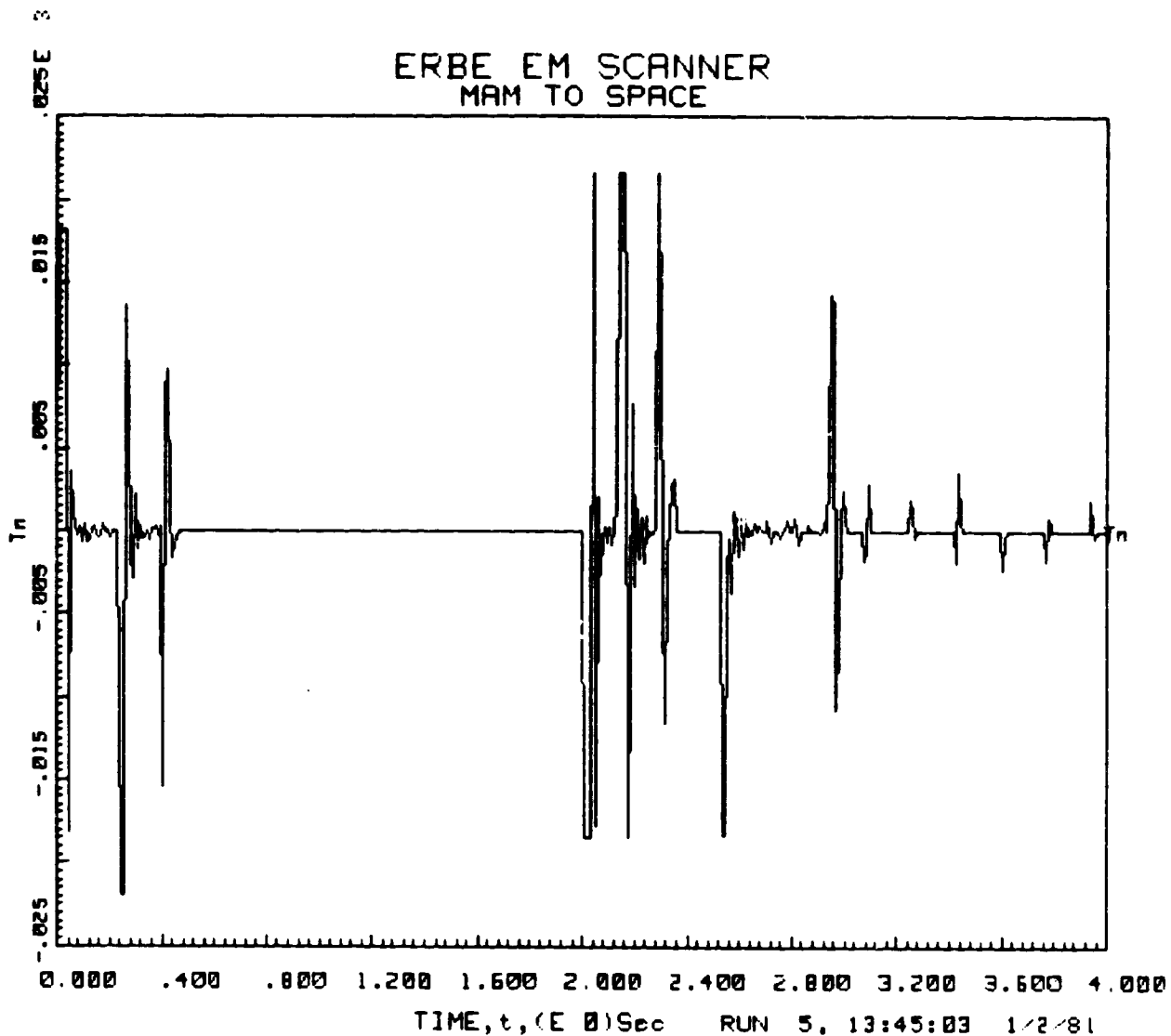

MAM SCAN NET TORQUE FIGURE 14

ERBE EM SCANNER
SCAN TO STOW

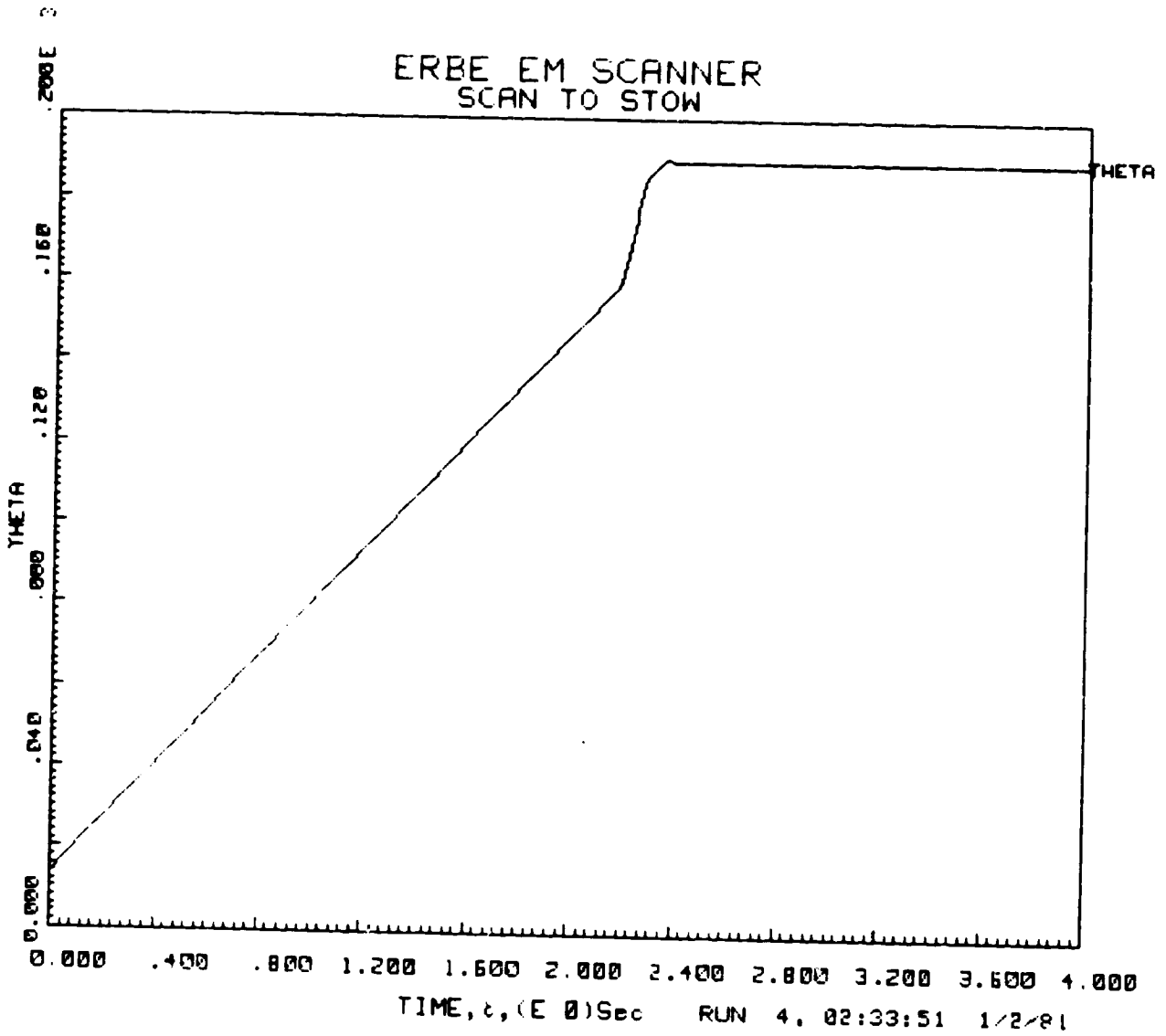

SCAN TO STOW POSITION FIGURE 15

ERBE EM SCANNER
SCAN TO STOW

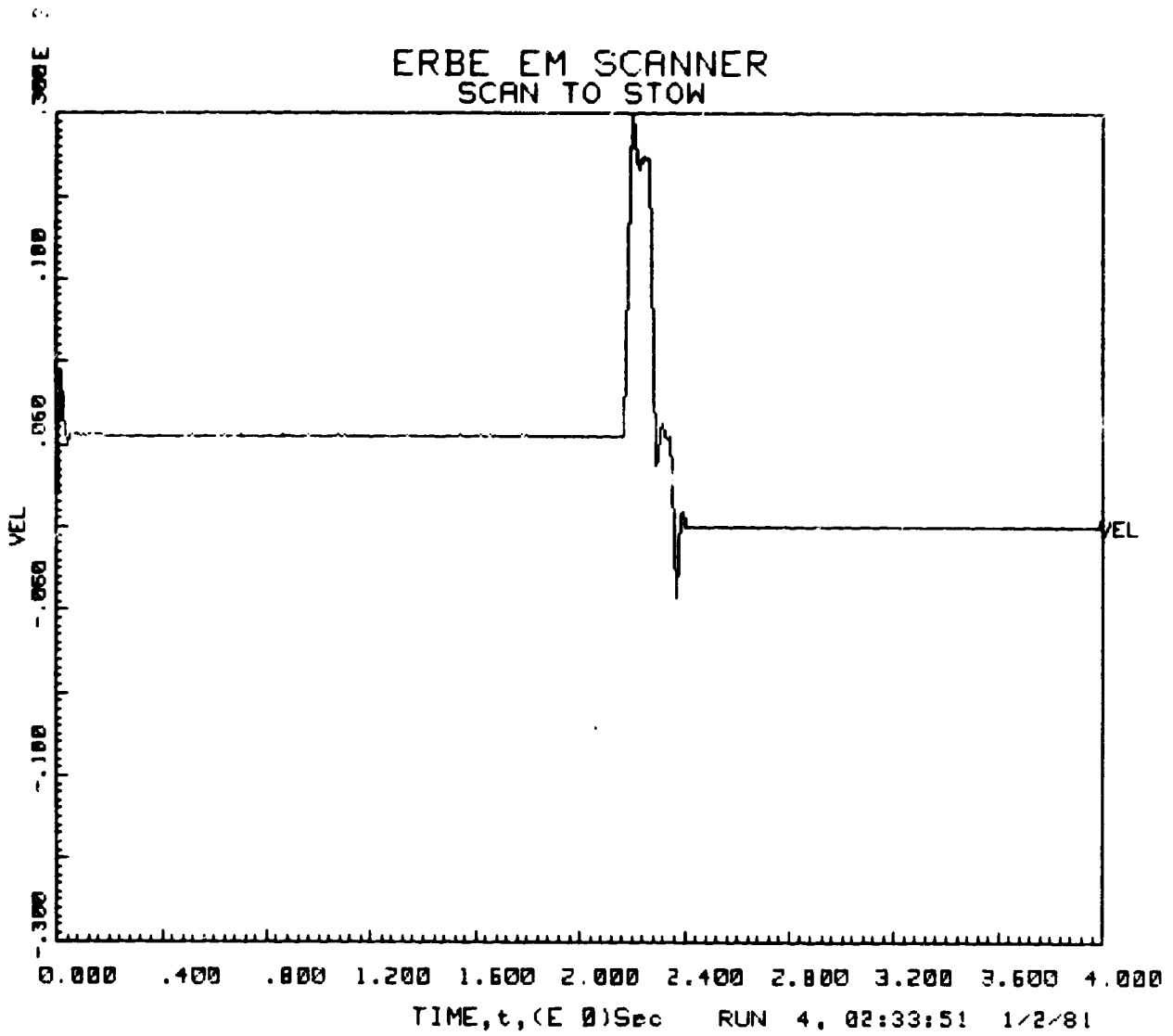

SCAN TO STOW VELOCITY FIGURE 16

ERBE EM SCANNER
SCAN TO STOW

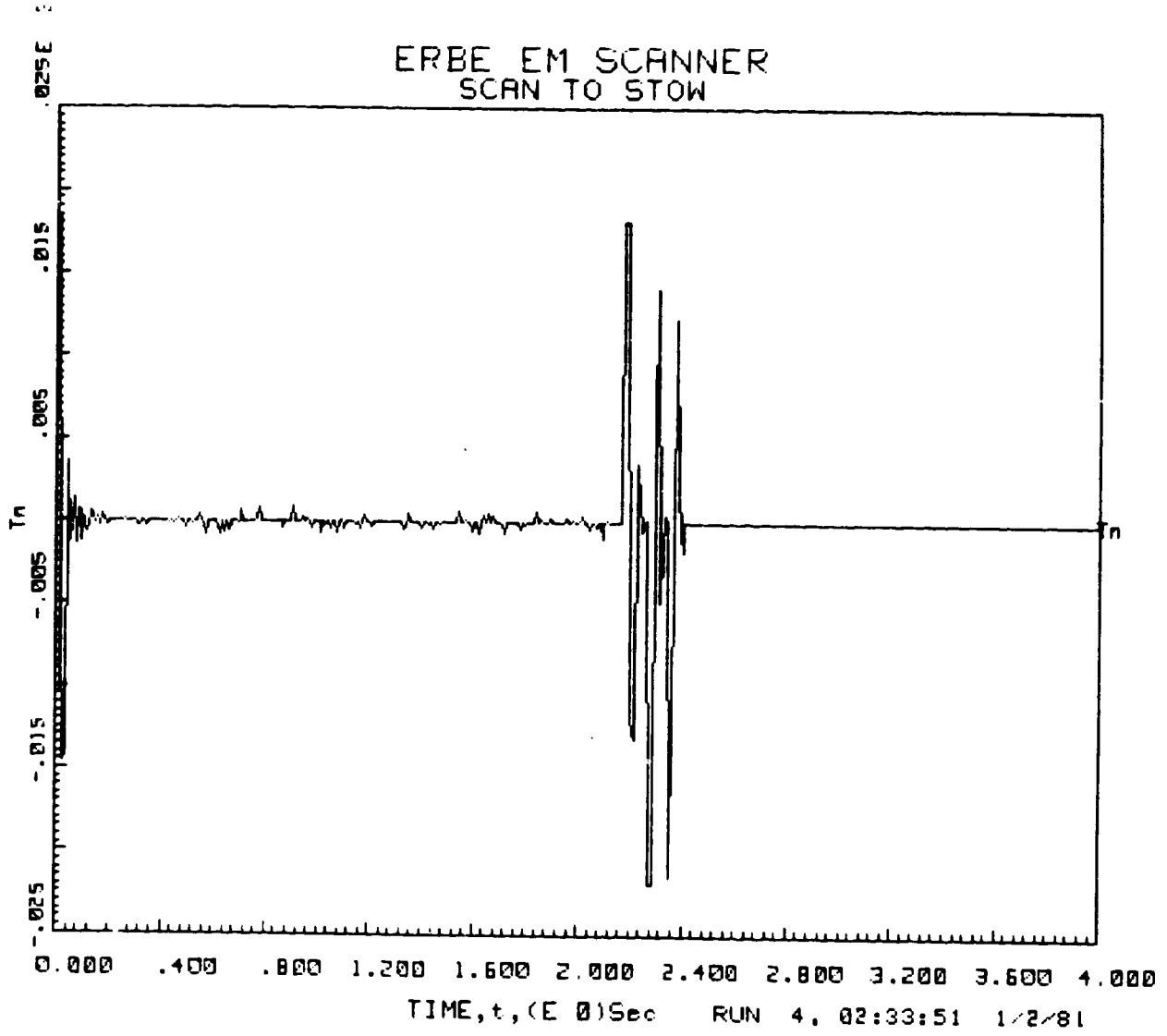

SCAN TO STOW NET TORQUE FIGURE 17

o INVESTIGATION APPROACH

o AREAS INVESTIGATED

Investigation Approach

The most important aspect of the approach was that no predetermined conclusions were to be entertained by the committee. All available clues given by the anomalies were to be analyzed in depth, all previous test data was to be reviewed, and all systems on the Scanner were to be looked at in detail for any identifiable faults which could explain the observed anomalies. This included the electrical, electronic, and mechanical systems, procedures and processes, flight data, analyses (thermal, mechanical, electrical, electronic) and any other tests or simulations which would provide some intelligence to help explain the problem. Also, any other identifiable sources of information in the Agency and industry which had expertise in any of the areas of the investigation would be consulted.

As noted in the introduction, a relatively complete account of the investigations in each of the previously identified areas will be given in the body of this report followed by the conclusions and recommendations. For those who are interested only in the executive summary, this is provided as a preface to this report.

The investigation team looked at the electrical, electronics, control system, and the mechanical scan system in detail. All of the possible anomalies which could occur in each system that could possibly explain the observed anomaly were listed. Each possibility was pursued to the point that it could be reasonably eliminated as a cause for the problem. Some of these were eliminated through logic, others required computer simulations, and in some cases tests and analyses were performed. The Life Test Model (LTM) was actually mechanically disassembled and inspected, and an in-depth look at the bearing assembly and lubrication design was conducted.

Areas Investigated

Test Data

Life Test Model (LTM), Engineering Model (EM), and Flight Model (FM)

A review of the ERBE Scanner LTM life cycle test data revealed no evidence of any sluggish scans such as was observed in flight. Because the LTM life cycle test was run to measure the parameters involved in assessing the operation of the polytwist, test data on the operation of the bearings and the scan motor instrumentation was lacking in sufficient detail to observe small changes in motor torque, motor speed, or bearing temperature. Post test results, however, showed no measurable changes in torque values on either the polytwist or the motor/bearing assembly. Records from all of the ground simulation, environmental, and calibration tests on both the Scanner EM and the three Scanner FM instruments failed to give any clues as to what would generate the observed anomaly.

Procedures and Processes

ERBE Scanner Assembly and Bearing Processing

The assembly procedures for the Scanner and the process specifications for all of the bearings were reviewed, and again no discrepancies which would help explain the observed scanner orbital problems could be identified. The bearings supporting the box beam in the main frame were lubricated and installed by Barnes Engineering Company (BEC). The encoder bearings were installed by the encoder manufacturer. The bearing parts were fabricated and material processes were done by the bearing manufacturer to specifications written by BEC. Although one of the final conclusions is the probability that the TCP treatment process contributed to the scanner anomaly, no evidence could be found that any procedure or process specification had been violated as it was written.

Simulation, Analysis, and Systems Design Reviews

Simulation of the ERBE Scanner Anomaly

The simulation program and model which were used to simulate possible causes of the ERBE Scanner anomaly were originally developed at Langley Research Center to evaluate the Scanner Servo Design and simulate its performance over the expected range of component/parameter variation. The overall performance of the model and the performance of the model during the critical transients were validated by comparison of simulated response with data from the Proto-flight unit (NOAA 9). The system elements which were represented in the original model include the encoder, encoder counter, velocity circuits, position circuits, servo compensation circuits, motor driver (linear approximation), motor, box beam mass, bearing friction, and polyflex capsule torque. All operational amplifiers were modeled as voltage limited linear devices.

The possible causes of the anomaly which were simulated fall into three categories: (1) single point logical/electronic failures which caused an improper functional mode to be enabled or disabled continuously (i.e. stuck in Boost Mode), (2) variations in gain or efficiency of electronic/electromechanical devices which causes an effective increase or decrease in gain at various points in the system, and (3) mechanical or electrical changes/failures which appear as an effective drag on the system (i.e. high friction).

Many of the the test cases were run by varying the values of parameters in the existing model. The only major change to the scanner model was the addition of a detailed representation of the high/low current switch circuits. Minor modifications were made as necessary to simulate various conditions which were considered possible causes of the observed anomaly. In all cases, when modifications were made the proper operation of the model was validated by setting the appropriate fault parameters to the non-fault condition and comparing the system response against baseline data, and by checking in detail the operation of the fault mechanism with the fault parameters in the fault condition.

The simulated response of the system was compared to the observed instrument data for the three conditions which are characteristic of the scanner anomaly: (1) did the first earth scan data point (actually the 9th data sample) shift negatively by 20 to 180 counts, (2) was the Earth scan uniformly linear (velocity = $66.7^\circ/\text{S}$) from the 9th data sample and, (3) what change occurred in the distribution of high and low power operation of the driver?

A summary of the cases which were run and the results of the runs are given in Table 1. None of the logical failures produced shifts of the first earth scan point anywhere near the magnitude observed in the flight units, and only those logical conditions in which the failure directly forced continuous high power mode was the average power usage significantly changed. Of the variations in gain and/or efficiency of components, only a 70 percent decrease in motor efficiency produced shifts in the first Earth scan point which were even close to those observed in the flight instruments. In that case the power usage remained essentially nominal, and linearity of the Earth scan began to show signs of deterioration.

There were two cases which produced the proper direction and magnitude of shift in the first Earth scan point, essentially continuous high power consumption and a nominal $66.67^\circ/\text{sec}$ Earth scan velocity. These two cases were: (1) an increase in mechanical friction and (2) an offset in motor driver current output. These conditions are analogous in nature and produce very similar response in the instrument simulations. The nature of the response is not a simple retardation of the instrument during Boost Mode but is a significant change in the nature of the transition from Boost Mode to closed loop velocity control as shown in figure 1. In addition to the fact that increased friction or electrical offset simulations match the three observed conditions on the flight units, a plot of change of the first earth scan data point versus friction, figure 2, may partially explain the 60 day period of nominal operation and the sudden occurrence and disappearance of the anomalous conditions. There is little change in the first earth scan count and the unit maintains essentially nominal power usage as the friction increases from the nominal value (0.5 in-oz) to approximately 5.5 in-oz. At approximately 5.5 in-oz. of frictional torque the unit abruptly shifts into high power usage with little or no transition region. At approximately the same point there is a sharp knee in the curve and the first earth scan count changes very rapidly for small variations in friction. This suggests that friction could have been increasing over the the 60 day period without causing any detectable change in performance, and that when the threshold level was reached the anomaly became apparent. This also suggests that it is not necessary for the scanner to "restore" itself to a like new condition for the anomaly to apparently disappear. The disappearance may represent only a small drop in friction below the threshold value.

Condition Simulated	First Count Shift	Power Level	Velocity Stability	Comments
No Boost Mode	-20	Nominal	Nominal	
Stuck in Boost Mode	-16	High	Poor	Probably will not complete scan.
Driver Stuck in High Current	-4	High	Nominal	
X 3 Gain in High Current	-4	Nominal	Nominal	
X 1/3 Gain in Low Current	-1	Nominal	Nominal	
Increased Controller Gain	-4	High	Nominal	20db Sweep. High Current above 12 db.
Decreased Controller Gain	+19b	Nominal	Poor	Velocity stability deteriorates below -8 db.
Loss of Motor Torque	-38	Nominal	Nominal	30% to 100% Sweep.
Increased Friction	-24	High	Nominal	1 to 10 in-oz Sweep. High Power above 0.5 in-oz. Sharp knee in curve.
Current Offset in Driver	-16b	High	Nominal	65% to 40% sweep. Similar to friction.

Summary of Results of EPAC Anomaly Simulations
Table 1



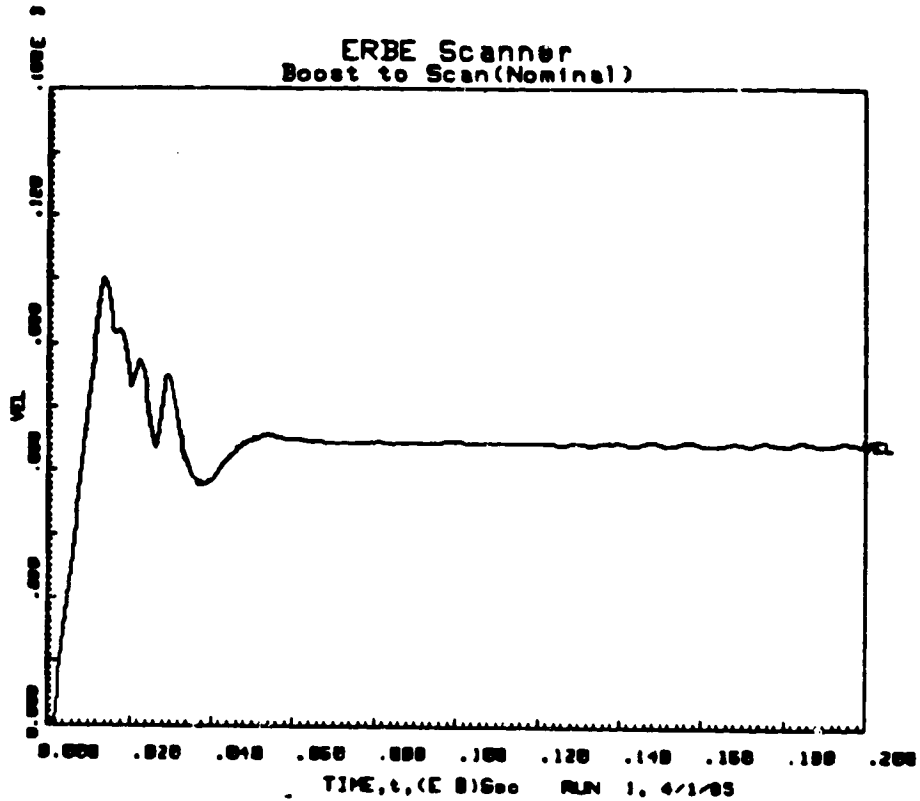

SIMULATION WITH NOMINAL FRICTION
FIGURE 1a

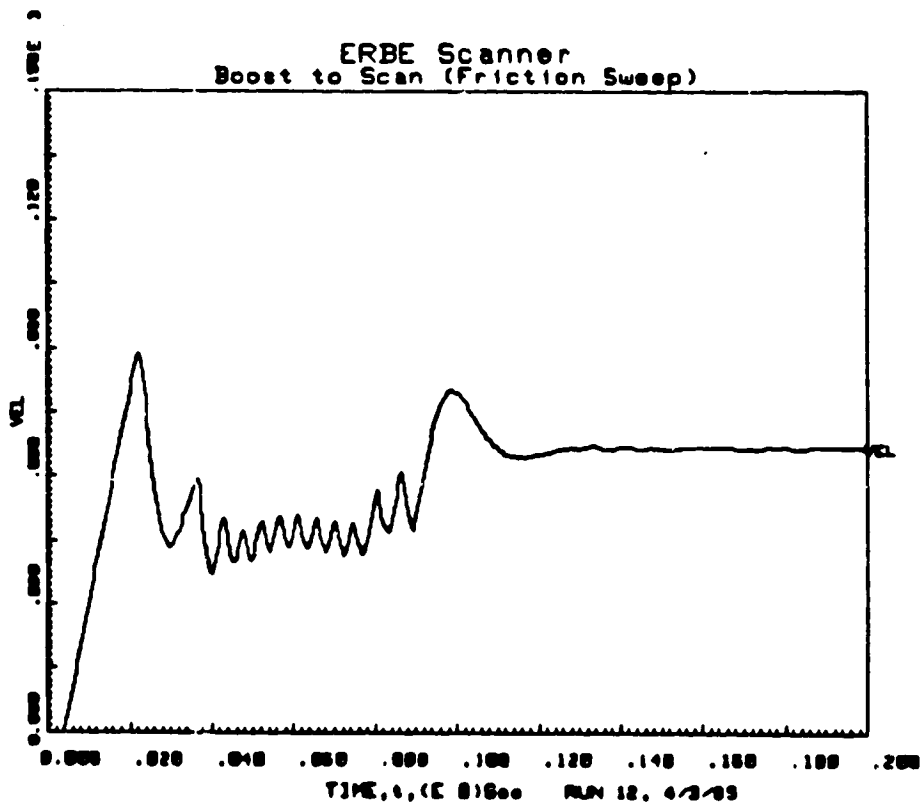

SIMULATION WITH 10 IN-OZ FRICTION
FIGURE 1b

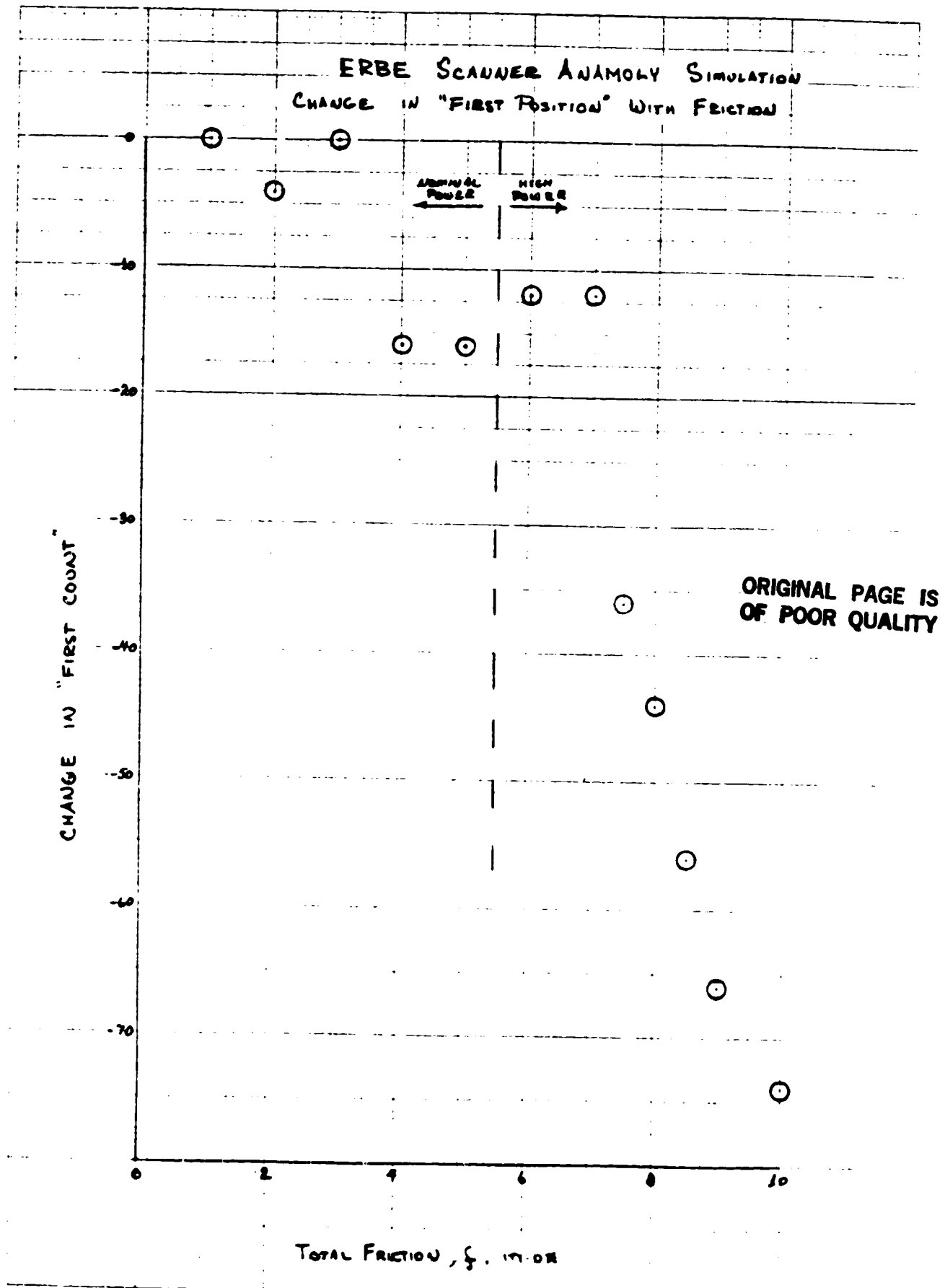

FIGURE 2

Thermal Analysis

As explained earlier, one other symptom associated with the sluggish scan anomaly was a rise in temperature. The Scanner instrument switches between two power levels during a scan in order to maintain the desired scan profile. These two drive levels are 200 ma and 66.7 ma per winding. The drive current level is selected by the control electronics. During the sluggish scans, every case was accompanied by a temperature rise of 7 to 8°C over a period of 8 to 10 hours. This temperature increase could be explained if the scan current level remained in the high current mode continuously. A simulation was ran of this condition of a continuous high current mode and a prediction of the power dissipated in the slice 3 cover and the motor was made. This was 2.9 watts and 5.6 watts respectively.

Using the fluxes for the NOAA 9, since the orbit plane-to-Sun angle for this spacecraft (approximately 35 degrees) does not vary significantly and the instrument temperature rises for the ERBS and NOAA-9 were similar in magnitude, the instrument temperatures were calculated on the NOAA-9 since they were predictable to a closer tolerance. These orbital fluxes were imposed on a reduced thermal mathematical model of the ERBE Scanner.

This model was expanded to include a more detailed description of the main electronics assembly (MEA). The previous model treated the MEA as a single node. The expanded model treated the MEA as six nodes including one internal node for each of the three electronics slices and a cover temperature node for each slice. This model was corrected to actual on orbit nominal measured data to within an accuracy of 1.4°C or less.

The MITAS-II computer program was then used to calculate the power required to generate the measured temperatures. The predicted power was the same as from the simulation and was 2.9 watts in the slice 3 cover and 5.6 watts in the motor stator in the instrument head. The largest variation between the analytical temperature predictions and the orbital measured data is about 1.5°C. From this analysis and simulation it could be reasonably concluded that the motor driver circuit stayed in the high power mode for 100 percent of the time during the sluggish scan modes. Also from that it was concluded that the temperatures resulting from this anomaly had peaked and that no higher temperatures were expected if the Scanner instrument was left continuously in the high power scan mode.

ERBE Scanner Anomaly Electrical Design Review

The electrical and electronic systems of the Scanner were studied through schematics, test documentation, and residual hardware, i.e. the Life Test Model and the Engineering Model. Circuits and devices were analyzed as applicable for stability, systematic or random logic failure, gain variation, and mechanical failures such as shorts or open circuits. Particular attention was given to the scan motor including detailed analysis of its construction, driver circuits, and the encoder and counter circuits.

Simulations were then performed to determine whether any of the above investigated potential failure mechanisms were capable of producing the anomalous performance observed on the flight units. (See the section on simulations for a description of the potential failure modes which were simulated and specific results of the simulations.) In addition tests were conducted on the Life Test Model to verify that the servo control electronics, driver electronics and the torque motor were still within specifications, and that the gains used in the simulation were valid. These tests involved driver and motor gain, driver linearity and offset, motor winding integrity and high/low current switching.

Based on the results of these analyzes, and simulations and tests, it was concluded that the probable cause of the Scanner anomaly is not degradation, or failure in, the ERBE Scanner Electronics.

Attention was then focused on the additional stress imposed on the electronics by operating continuously in high current mode. The affected components and circuits were analyzed, test results reviewed, and the thermal resistance of the driver power transistor heatsink configuration was verified by a test of the Life Test Model. Based on the results and tests it was concluded that the Scanner Electronics are not being over-stressed as a result of the anomaly.

Mechanical Design Review

A complete review of the ERBE Scanner mechanical design was conducted. This included a review of the design drawings and all the mechanisms associated with the instrument scan.

The ERBE Scanner head assembly has a rotating system that scans back and forth to obtain science data. The rotating system (figure 1) consists of six major mechanical parts: (1) polytwist, (2) scan motor, (3) encoder, (4) flex coupling, (5) bearings, and (6) box beam. The box beam holds the three detectors and their associated electronics. The beam is supported by a single bearing on one end and a duplex pair bearing set on the opposite end. A polytwist cable assembly (figure 2) is located at the single bearing end of the box beam. The polytwist provides a means to bring the detector electronic signals across a rotating system via wires. The bearings are preloaded by a set of 12 springs at the polytwist end of the box beam (figure 3). The preload is 20 lbs. along the axis rotation of the box beam. The box beam is rotated by a brushless d.c. torque motor consisting of two parts: the rotor and stator. The stator is securely clamped to the main frame of the Scanner head. The rotor is attached to the box beam shaft with a key and jam nut. A .020 inch gap is maintained between the rotor and stator. Further information on the motor is shown in figure 4.

The encoder (figure 5) is a rotary incremental counter used to determine box beam position. The encoder mechanically consists of an optical wheel attached to a rotating shaft that is supported by a duplex pair of ball bearings. The rotating shaft of the encoder is attached to the box beam through a flex coupling.

(+)

The flex coupling (figure 6) is a bellows type construction made of 300 series stainless steel. The bearings, both the single and duplex pair, are standard ball angular contact bearings with a phenolic retainer.

An indepth examination was made of each of the mechanical components listed above to determine the potential failure in each component, the effect that failure would have on the scan system, and the probability of the failure occurring. The failure modes examined were based on the potential effect the failure would have on the Scanner and that would agree with the observed anomaly condition. The results of this examination are summarized in Table 1. A detailed discussion of each component's effect in relation to the Scanner anomaly follows:

Polytwist

The most likely failure in the polytwist would be one that would cause the cable wrap to rub on either the polytwist housing, box beam housing, or the cable itself. This rubbing would increase the torque in the rotating system thus causing higher motor current to be used. If rubbing was occurring, eventually the insulation surrounding individual wires would be worn through and shorting of the wires to each other or to the housings would occur. This shorting would lead to a loss of signal. Since Scanner FMI on the ERBS spacecraft, has experienced the anomaly for more than six months with no loss of any signal from the Scanner head, the probability of this being the generator for the anomaly is small. In addition a life test was performed on a flight type polytwist that simulated a one year mission. The analysis of that test unit indicated no significant wear of the cable wrap.

Motor

The most probable mechanical failure mode in the motor is foreign particles lodging in the gap between the rotor and stator. In order for these particles to migrate into the gap, they would have to be magnetic and pulled into the gap by the permanent magnet in the rotor. Lodging of metallic particles in the gap would cause increased torque in the drive system.

Investigation of all materials contained in the Scanner head indicate no magnetic metals had been used. A secondary failure of the motor is the possible slipping of the stator in the main frame housing. This failure would only cause an increase in motor power, not the change in the scan profile. Both scan motors failing in this manner have a small probability of being the cause of the anomaly.

Flex Coupling

There are two types of possible mechanical failures in the flex coupling: (1) flex coupling is loose on the encoder/box beam shafts and (2) the flex coupling is flexing in torsion. If the coupling was loose on either shaft, the result would only be an incorrect position indication and not high motor

current or increased torque. The same result would occur if the coupling was flexing in torsion. However, the coupling has flats on both ends that mate with flats on both shafts thus precluding looseness between the coupling and the encoder. Also, the flex coupling has 700 in-oz torsion capability without deforming. This capability is 35 times greater than the 20 in-oz capacity of the motor. The probability of the flex coupling being a contributor to the Scanner anomaly is small.

Encoder

The encoder has two major mechanical parts that could be a factor in the behavior of the scan system. The duplex pair bearing supporting the encoder shaft is one part. The discussion of the potential bearing failure mode will be discussed in detail in a later section of this report under bearings in general. The other major part is the optical wheel. There are two failure modes involving the optical wheel: (1) the wheel is rubbing on internal parts of the encoder and (2) the wheel is loose on the encoder shaft. The first failure of the wheel would cause an increase in the scan system torque. However, because of the design of the wheel, this rubbing would cause a loss of position signal. This type anomaly has not occurred. The second failure of the optical wheel would only give incorrect box beam position indications and not the anomaly that has occurred. The optical wheel has a small probability of being the cause of the anomaly.

Bearings

The three bearings in the scan system and encoder have a similar design in that they are spherical balls retained in a phenolic retainer. The ball/retainer is positioned between unshielded inner and outer races. The phenolic retainer is saturated with a liquid lubricant. The two main bearings supporting the box beam are the angular contact type and the bearing in the encoder is a deep groove type. The physical configurations are shown in figures 7-12. There are six major malfunctions in the bearings that could have an effect on the scan profile:

- (1) Loss of lubricant would increase the torque of the scan system. The vapor pressure of the lubrication oil-Braycote 815Z is advertised as $>1 \times 10^{-9}$ torr at 38°C (figure 13). The vacuum state at the satellites' orbits (ERBS-600km, TIROS- 850km) is approximately 1×10^{-12} torr. Considering the labyrinth design of the bearing retainers and the vapor pressure of the oil, it is unlikely that a significant amount of the oil has outgassed.
- (2) Foreign particles in the ball-race interface will cause higher torques to be developed in the system. Contamination control of the bearing assembly and lubrication processes was maintained at a class 100 condition. The probability of foreign matter getting into the bearings on two different instruments is very small.

- (3) Imperfections of sufficient size on a ball or race would contribute to higher torques on the scan system. Again the probability of having imperfections in bearing parts in two different instruments is very small considering the inspection and testing of each bearing as shown in the bearing specifications.
- (4) A change in the bearing preload may affect the scan system's torque. The actual effect of either an increase or decrease in the preload is not completely known, however, it is assumed that a large change in preload would have to occur in order to significantly increase the torque of the system to the level necessary to cause the scan anomaly. The spring system used to induce the preload would compensate for any structural movement in the main frame that might tend to change the bearing preload. The probability of a preload change being the cause of the anomaly is small.
- (5) The bearings could have been installed improperly in the main frame housing. If the single bearing was installed in a reversed position, the bearing retainers would have pressed on the wrong bearing races. This would have increased the torque of the scan system to a level beyond the capability of the scan motor. This condition would have been discovered early in the assembly process of the scanner head. If the duplex pair in either the main frame or the encoder was installed in a reverse position, there would be no change in the torque of the system due to the configuration of a duplex pair. The probability of improper installation of the bearings being the anomaly condition is small.
- (6) The last possible failure mode is an improper lubrication technique used in the design of the bearings. Due to the slow speed of the scan profile (maximum of $26^\circ/\text{sec}$ or 45 rpm) the lubrication oil may not develop sufficient boundary layer conditions to flow between the balls and the races since this is a reversible motion which occurs every four seconds. This condition would lead to metal on metal contact and eventual wear and pitting of the races and balls. The wear on the races and balls that were not being lubricated would cause an increase in friction and torque of the scan system. The probability of this being the cause of the scanner anomaly is very high.

Life Test Unit

A life test unit was fabricated and tested at Barnes Engineering Company in 1962. The major purpose of the life test was to determine the life expectancy of the polytwist. The physical configuration of the life test unit scanner assemble is shown in figure 14. The unit was cycled approximately 11×10^6 times in a 10^{-3} torr vacuum at room temperature. The rate of cycling was four times the normal scan speed. The scan angle was 176° . The bearings used in the life test unit were flight type bearings. These bearings were inspected and lubricated identical to the flight bearings except that they were not subjected to all of the tests as specified in BEC50-126 and BEC 50-127. The box beam was simulated by a cylindrical mass so that the radial load on the bearings was similar to the flight instrument while on the ground. The axial preload was identical to the flight load of 20 lbs.

The single bearing was removed from the life test unit in June 1985, and taken to the NASA Lewis Research Center for analysis. The results of that analysis will be covered in the next section.

Break Torques

Prior to removal of any hardware from the life test unit, break torque measurements were taken of the complete scan system. The life test unit was supported so that the scan rotation axis was perpendicular to the floor to eliminate any radial loading on the bearings. The break torques were measured at specific locations both in a clockwise (cw) or counter clockwise (ccw) direction. Specific parts were removed after each set of measurements to determine if any one part was the major contributor to the break torque value. The results of the break torque measurements are shown in Table II.

A similar set of measurements were made on the ERBE Scanner Engineering Model. The results of these measurements are given in Table III.

The conclusion drawn from the break torque measurements is that the break torque values did not change as major parts were removed. The break torque of the system with only the bearings present indicated an increase in friction from previous torque values taken during bearing assembly and test at the bearing manufacturer. However, this apparent increase in torque was not sufficient to indicate a problem with the bearings.

Bearings

The bearings used in the ERBE scanner instruments were manufactured by MPB Corporation, Split Ballbearing Division. The main frame bearings were lubricated and installed by Barnes Engineering Company (BEC). The encoder bearings were lubricated and installed by the encoder manufacturer to BEC specifications. The main frame bearings are angular contact, non-shielded designs and the encoder bearing is a deepgroove non-shielded design. The balls and inner and outer races are made of 440C stainless steel with a Rockwell hardness of C60 to C65. The ball and races have been passivated according to Federal Specification QQ-P-35 and have been treated with Tricresyl Phosphate for antiwear according to specification BEC PM-87. The retainer ring is a cotton based phenolic. The configuration with dimensions of the bearings are given in figures 7-12. The bearings are lubricated with Brayco Micronic 815z oil per the specification BEC PM-75.

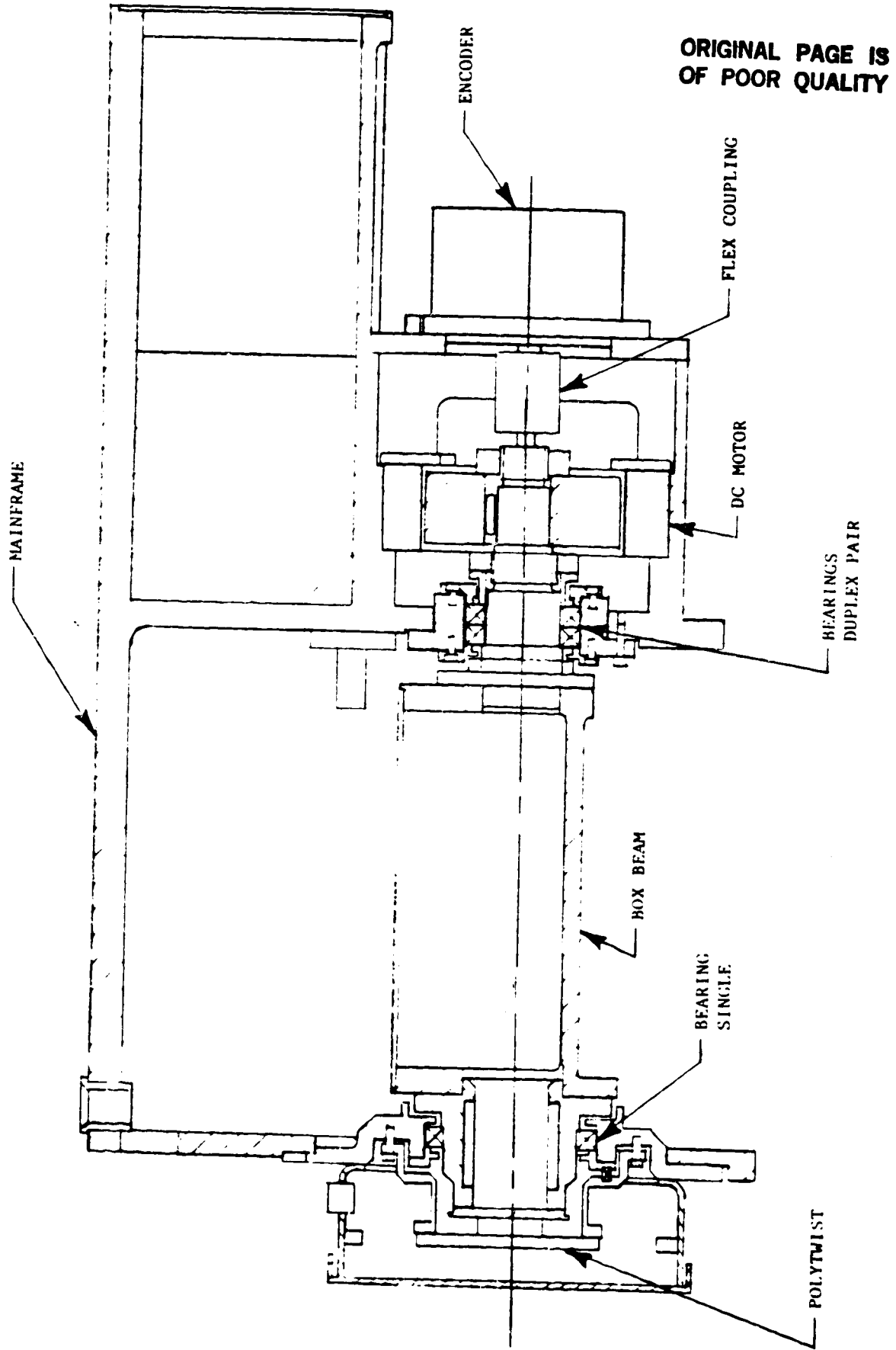

Figure 1 SCANNER HEAD ASSEMBLY

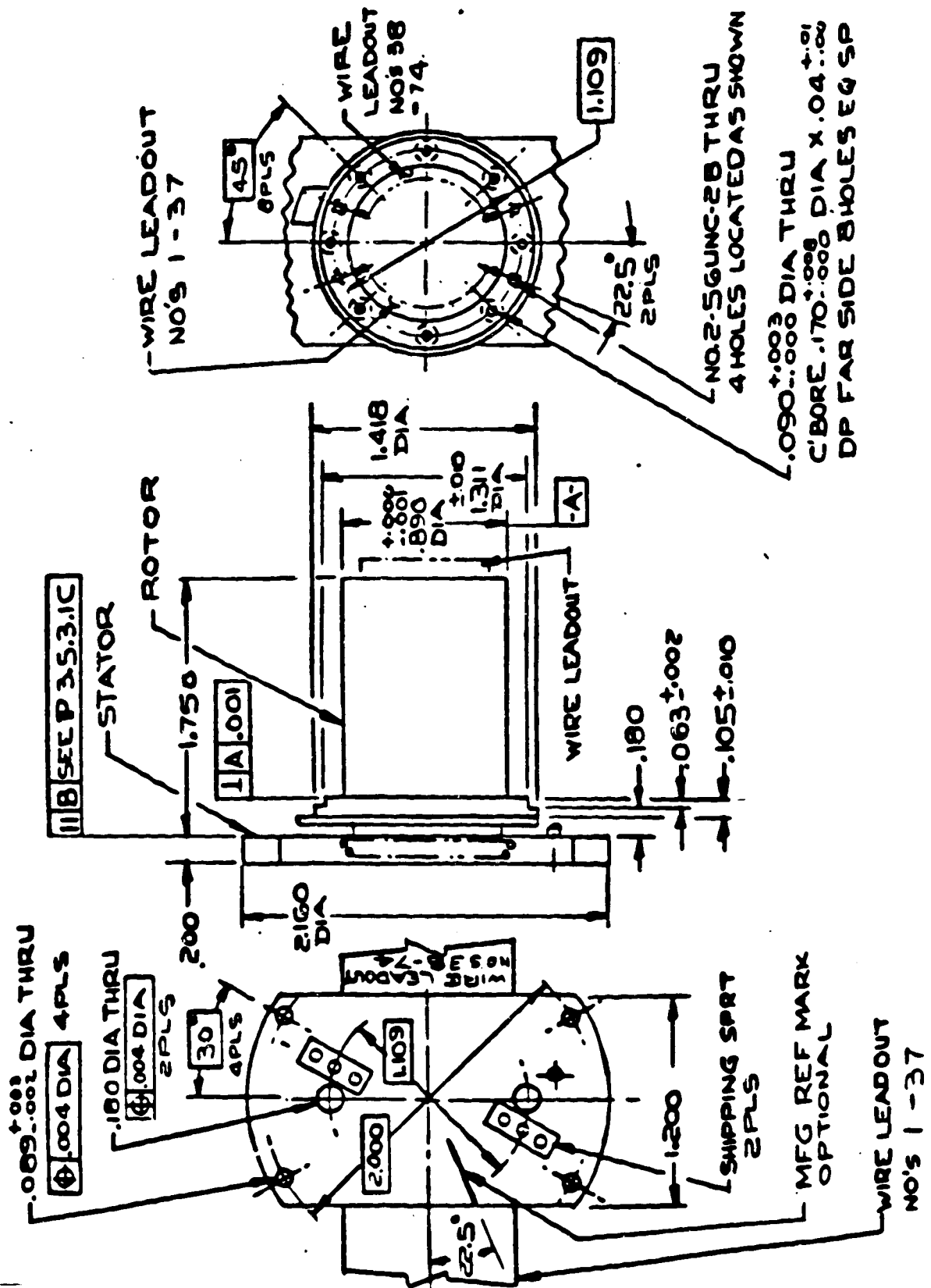

Figure 2 ERBE SCANNER POLYTWIST

ORIGINAL PAGE IS
OF POOR QUALITY

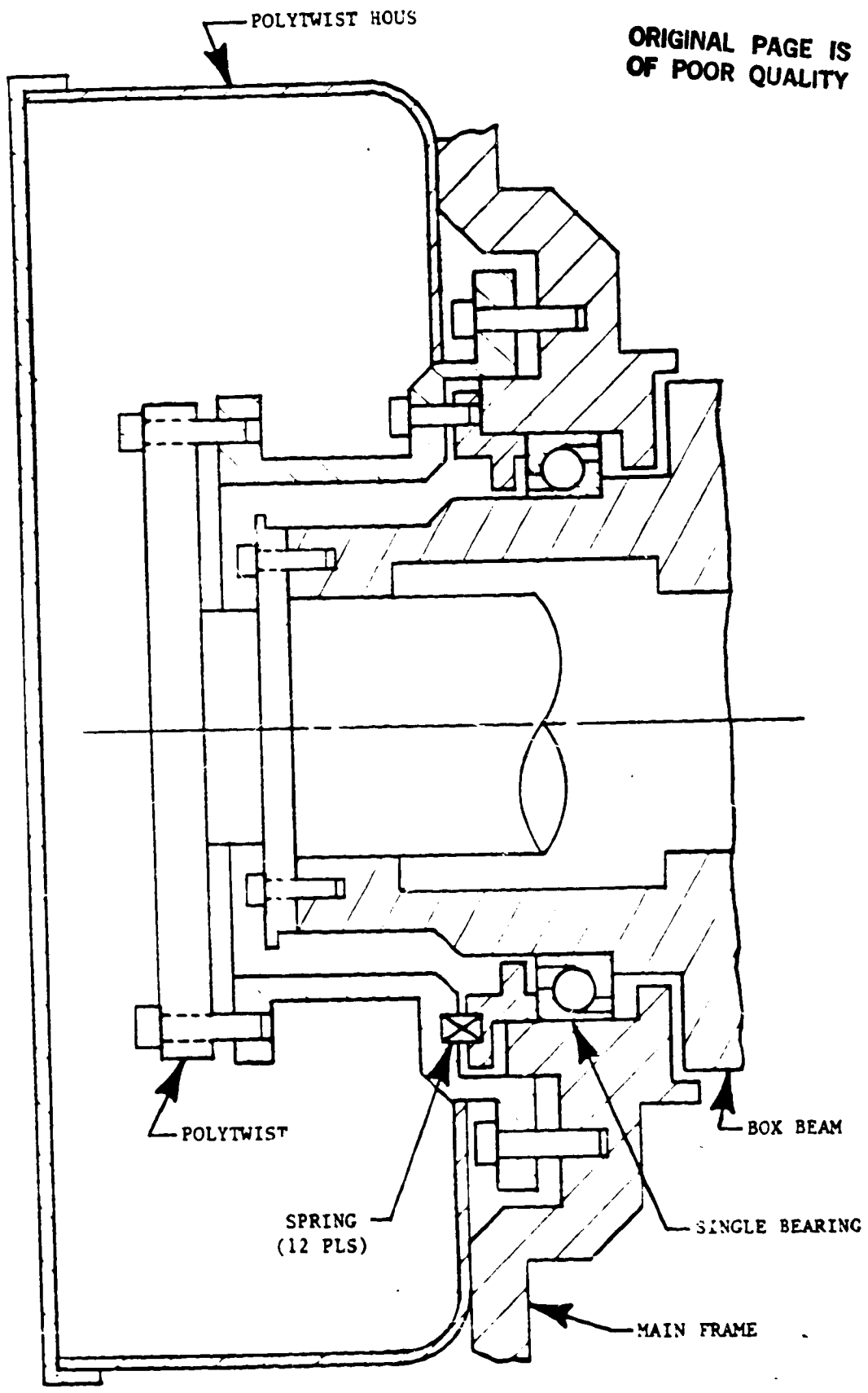
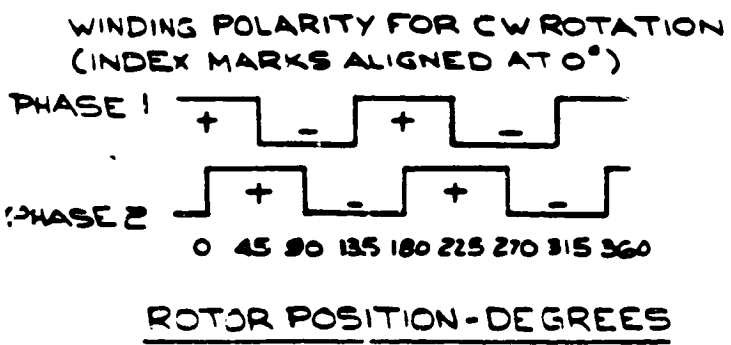
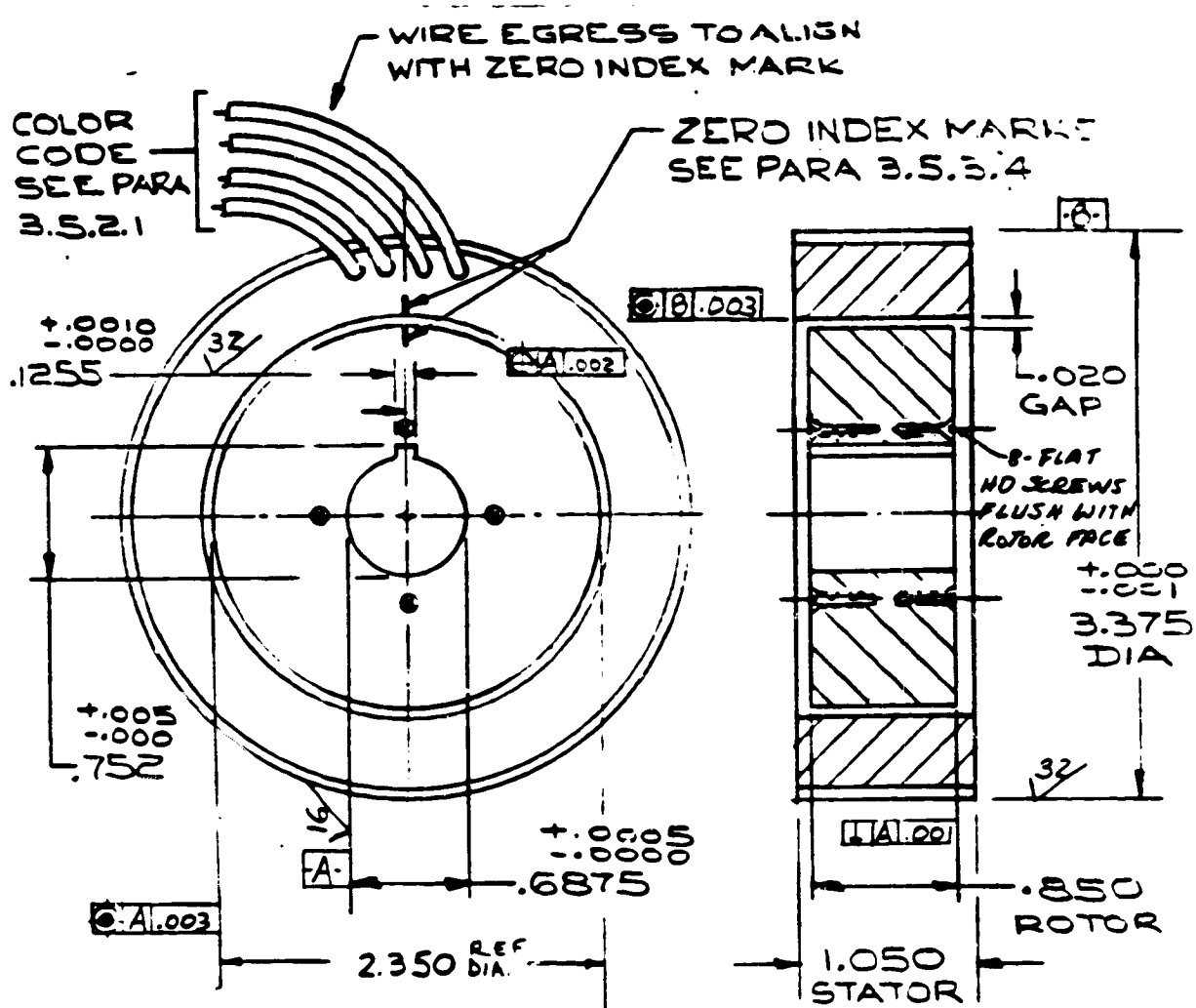
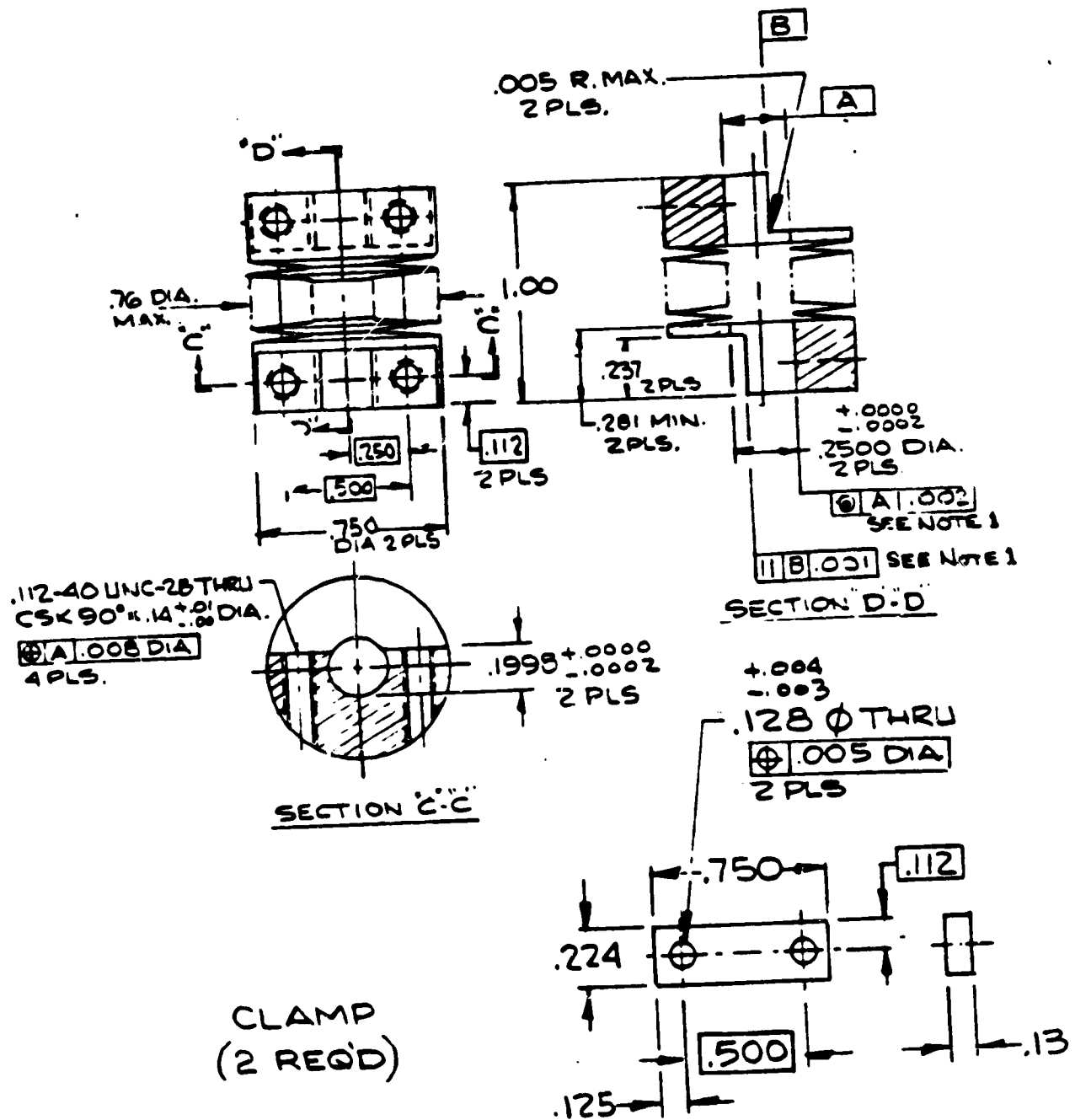

Figure 3 POLYTWIST/BEARING ASSEMBLY



- NOTES**
- ① POLARITY IS SHOWN FOR ϕ_{1A} WITH RESPECT TO ϕ_{1B} AND FOR ϕ_{2A} WITH RESPECT TO ϕ_{2B}
 - ② BREAK EDGES OF KEYWAY & ROTOR BORE .005 MAX
- SEE PARA 3.5.2.1

Figure 4 ERBE SCANNER DC BRUSHLESS MOTOR



NOTE 1 DIMENSIONS APPLY WITH HUBS CONSTRAINED

CLAMP
(2 REQ'D)

FIGURE 6 ERBE SCANNER FLEX COUPLING

TABLE I-ERBE SCANNER ANOMALY-MECHANICAL FAILURE SUMMARY

<u>ITEM</u>	<u>OCCURANCE</u>	<u>EFFECT</u>	<u>PROBABILITY</u>
1. Polytwist	A. Cable Wrap Rubbing	Increase in Torque	Wearing Through Insulation-Short in Leads-Loss of Signal
2. Bearings	A. Loss of Lubricant	Increase in Torque	Low Vapor Pressure < 1×10^9 Torre
	B. Foreign Particles in Races	Increase in Torque	Possible on One Instrument, but Not on Two.
	C. Bad Place on Ball/Rack	Increase in Torque	Possible on One Instrument But Not Two.
	D. Increase/Decrease in Preload	Unknown	Assume It Would Take Large Change to Have Effect.
	E. Improperly Installed	Increase in Torque on Single Bearing.No Effect on Duplex Pair	Torque Increase Beyond Motor Capability.
	F. Improper Lubrication Technique	Increase in Torque	Slow Speed Application of Oil-High Probability
3. Motor	A. Foreign Magnetic Particles in Motor	Increase in Motor Torque	No Magnetic Materials in Motor Cavity
	B. Stator Slipping in Housing	Increased Motor Power	Shorting of Windings to Main Frame

ERBE SCANNER ANOMALY

-MECHANICAL SYSTEMS-

-CON'T-

<u>ITEM</u>	<u>OCCURANCE</u>	<u>EFFECT</u>	<u>PROBABILITY</u>
4. Flex Coupling	A. Loose on Shafts	Incorrect Position Indication	Flats on Shafts
	B. Flexing in Torsion	Incorrect Position Indication	700 oz-in Capability Without Deforming
5. Encoder	A. Bearings-Same as 2.	Same as 2.	Same as 2.
	B. Wheel Rubbing on Internal Parts	Increased Torque	Loss of Position Signal
	C. Wheel Loose on Shaft	Incorrect Position Indication	Scan Profile Would Deteriorate until Scan Stopped.

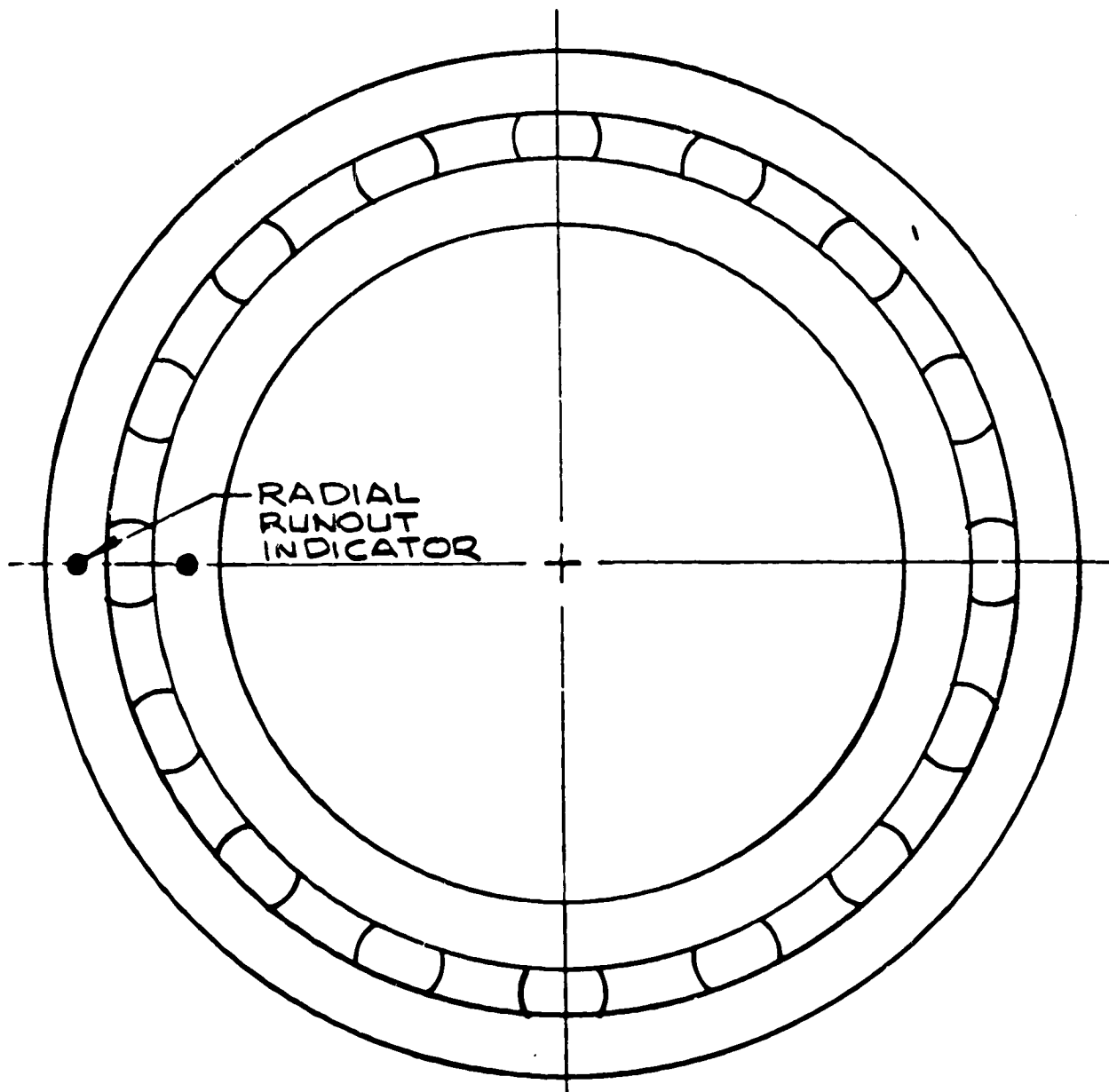
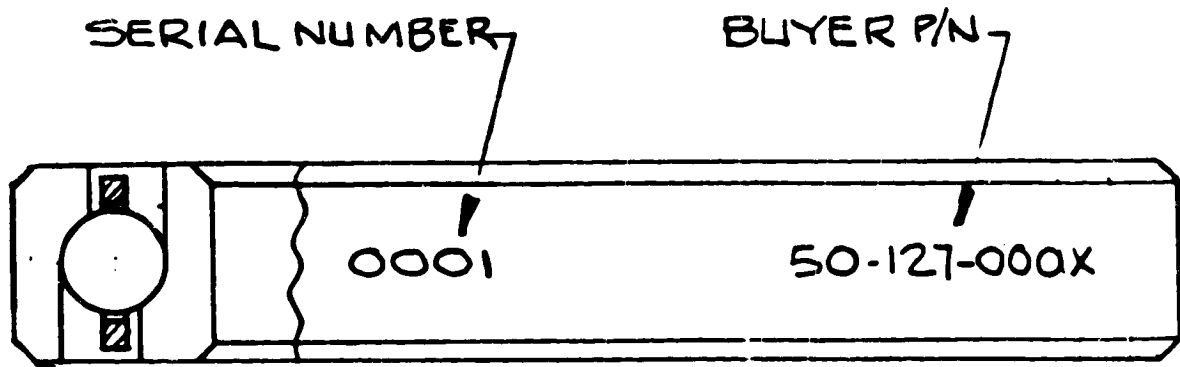

FIGURE 7 ERBE SCANNER MAIN FRAME SINGLE BEARING CONFIGURATION

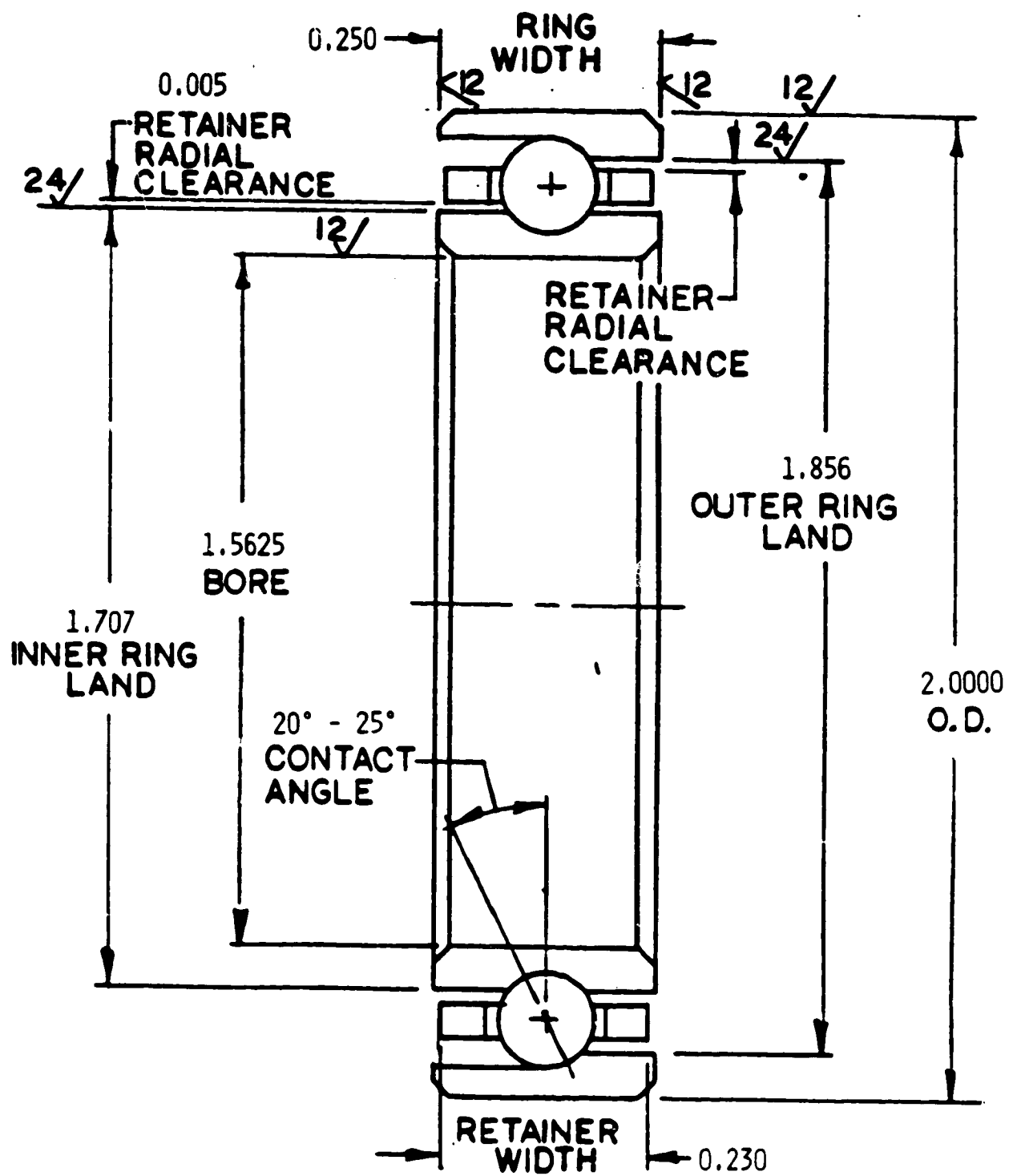

FIGURE 8 ERBE SCANNER MAIN FRAME SINGLE BEARING DIMENSIONS

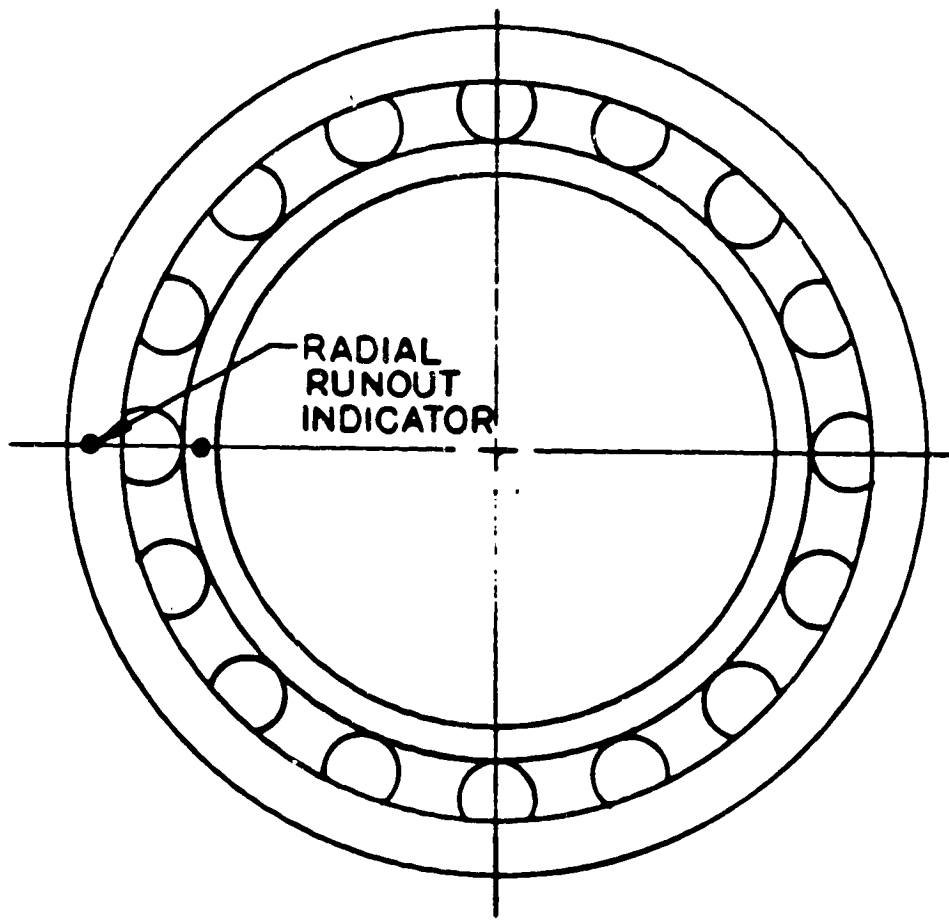
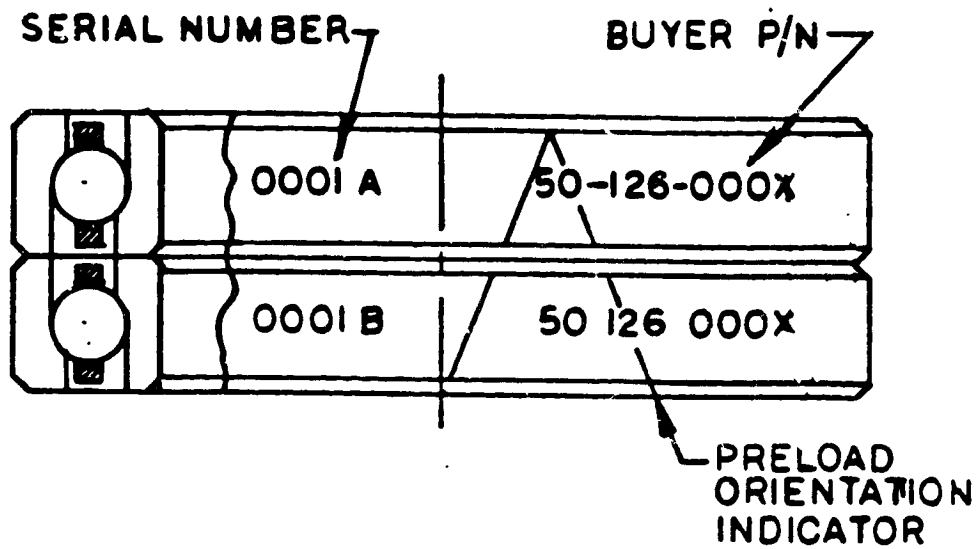

FIGURE 9 ERBE SCANNER MAIN FRAME DUPLEX PAIR BEARING CONFIGURATION

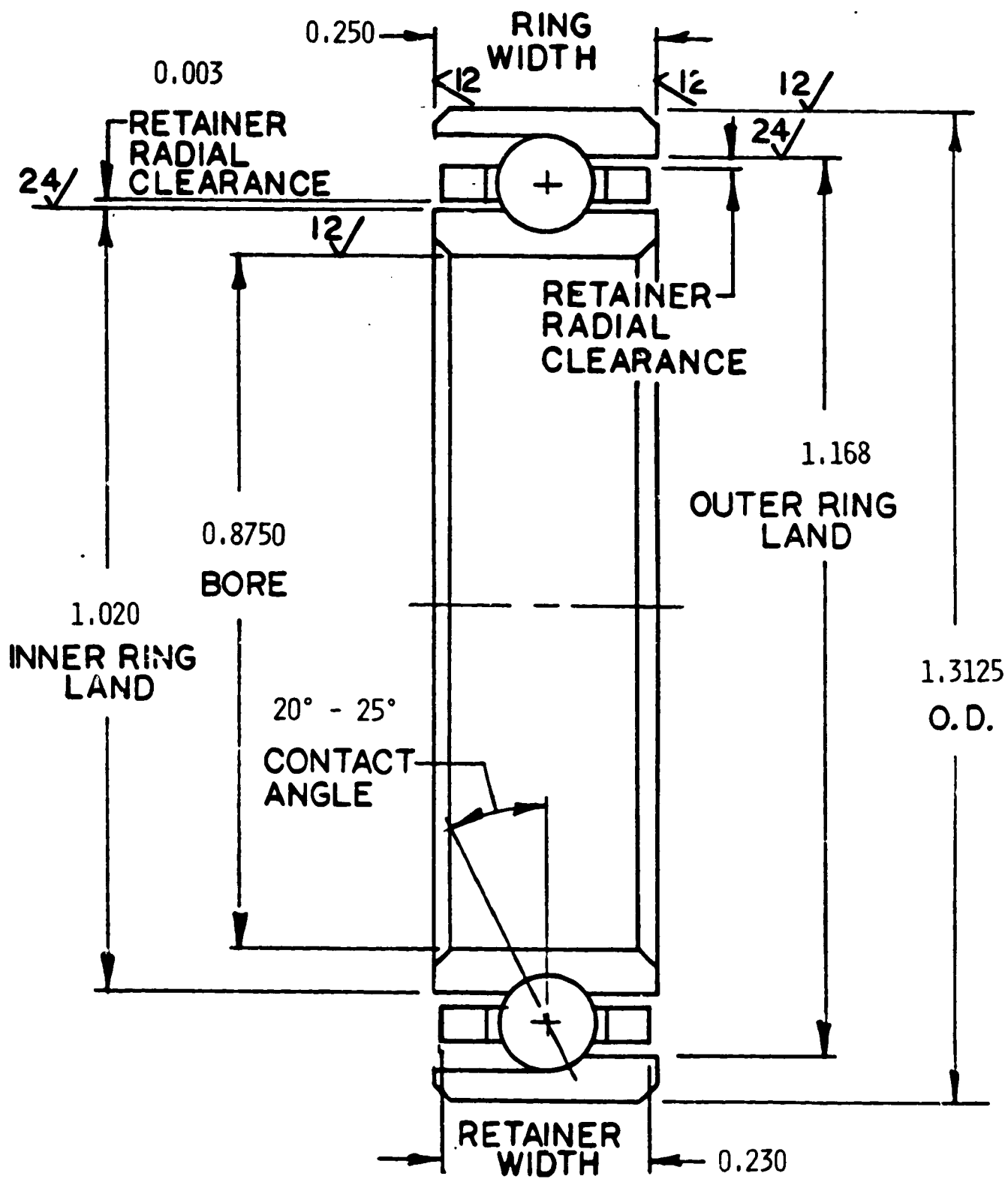
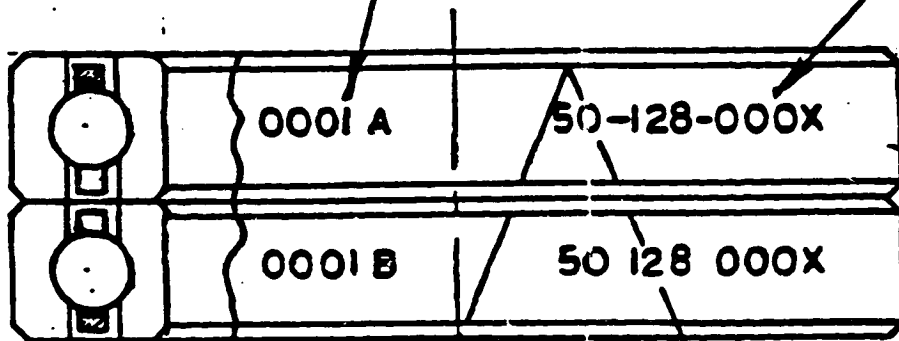

FIGURE 10 ERBE SCANNER MAIN FRAME DUPLEX PAIR BEARING DIMENSIONS

ORIGINAL PAGE IS
OF POOR QUALITY

SERIAL NUMBER

BUYER P/N



PRELOAD
ORIENTATION
INDICATOR

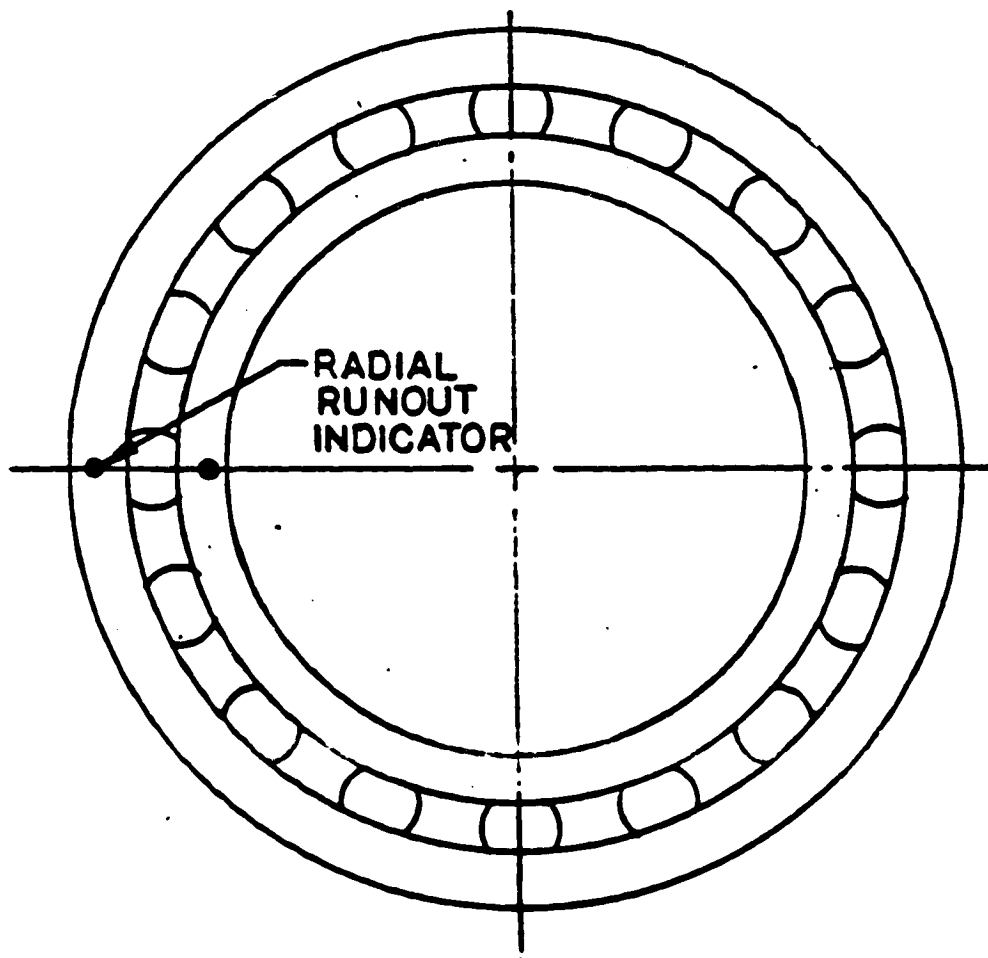

FIGURE 11 ERBE SCANNER ENCODER DUPLEX PAIR BEARING CONFIGURATION

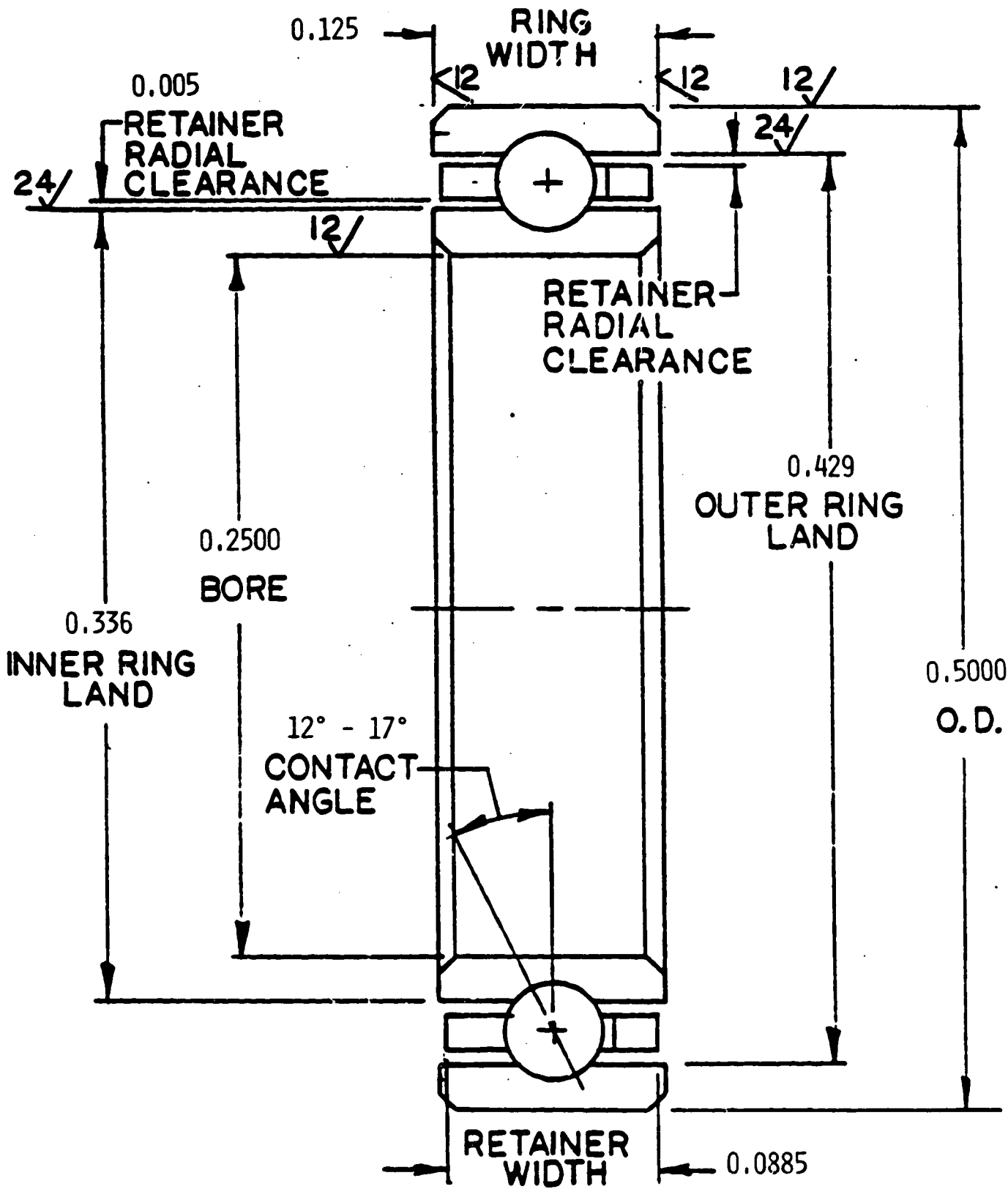

FIGURE 12 ERBE SCANNER ENCODER DUPLEX PAIR BEARING DIMENSIONS



ORIGINAL PAGE IS
OF POOR QUALITY

BRAYCO OIL COMPANY

Hughes
HMS 20-1830

BRAYCO® MICRONIC 815Z HYDRAULIC FLUID AND LUBRICATING OIL, SYNTHETIC, ROCKET PROPELLENT COMPATIBLE, HIGH TEMPERATURE

DESCRIPTION: BRAYCO® 815Z is a clear water white fluid. The fluid's base is a perfluorinated poly-ether. The fluid is practically chemically inert, compatible with rocket propellents and oxidizers, is unaffected by ultra violet, cosmic radiation, or high vacuums. It has an exceptionally high viscosity index and low volatility, and has little tendency to form deposits. It exhibits excellent lubricating properties, good dielectric properties, excellent shear stability and low toxicity.

USES: BRAYCO® 815Z is practically insoluble in current fuels and oxidizers, as well as in most organic solvents. BRAYCO® 815Z is intended for aerospace use, and has been used successfully in many space missions: It is particularly suited for deep space missions where extreme vacuums and wide temperature variations, -84.4°C to 260°C (-120°F to 500°F) are routine.

LIMITATIONS: BRAYCO® 815Z may be adversely affected by Lewis Acids catalysts such as ALCL₃ at elevated temperatures. Newly exposed rubbing surfaces of aluminum or magnesium at temperatures of 205°C (400°F) and above should be evaluated for corrosiveness.

PACKAGING: BRAYCO® 815Z is packaged in one pound containers. Other containers are available on special request.

PROPERTIES

Method (ASTM)	Test	Typical
D-287	Gravity, Specific 15.5°C/15.5°C (60°F/60°F)	1.866
Table 8	Pounds/gallon	15.4
D 445	Viscosity @ 205°C (400°F), cs	11
D.445	Viscosity @ 98.9°C (210°F), cs	40
D 445	Viscosity @ 37.8°C (100°F), cs	129
D 445	Viscosity @ -17.8°C (0°F), cs	450
D.445	Viscosity @ -40°C (-40°F), cs	2600
D.445	Viscosity @ -53.9°C (-65°F), cs	6700
D-2270	Viscosity Index	350
D 92	Flash (Halogen Halo)	259°C (570°F)
D 97 Mod	Pour Point	< -73°C (-100°F)
HMS 20-1830	Vapor Pressure, Torr	
	38.8°C (100°F)	< 1 x 10 ⁻⁹
	205°C (400°F)	< 1 x 10 ⁻⁴
NASA SPR 0022	Vacuum Weight Loss, %	0.8
NASA SP R 0022	Volatile Condensable Material, %	.05
FTM-3009	Solid Particle Contamination, Number of Particles per 100 ml	
	5-15 microns	150
	16-25 microns	45
	26-50 microns	23
	51-100 microns	3
	+100 microns	Nil

ALTI

Figure 13

ERBE SCANNER BEARING LUBRICATION OIL SPECIFICATIONS

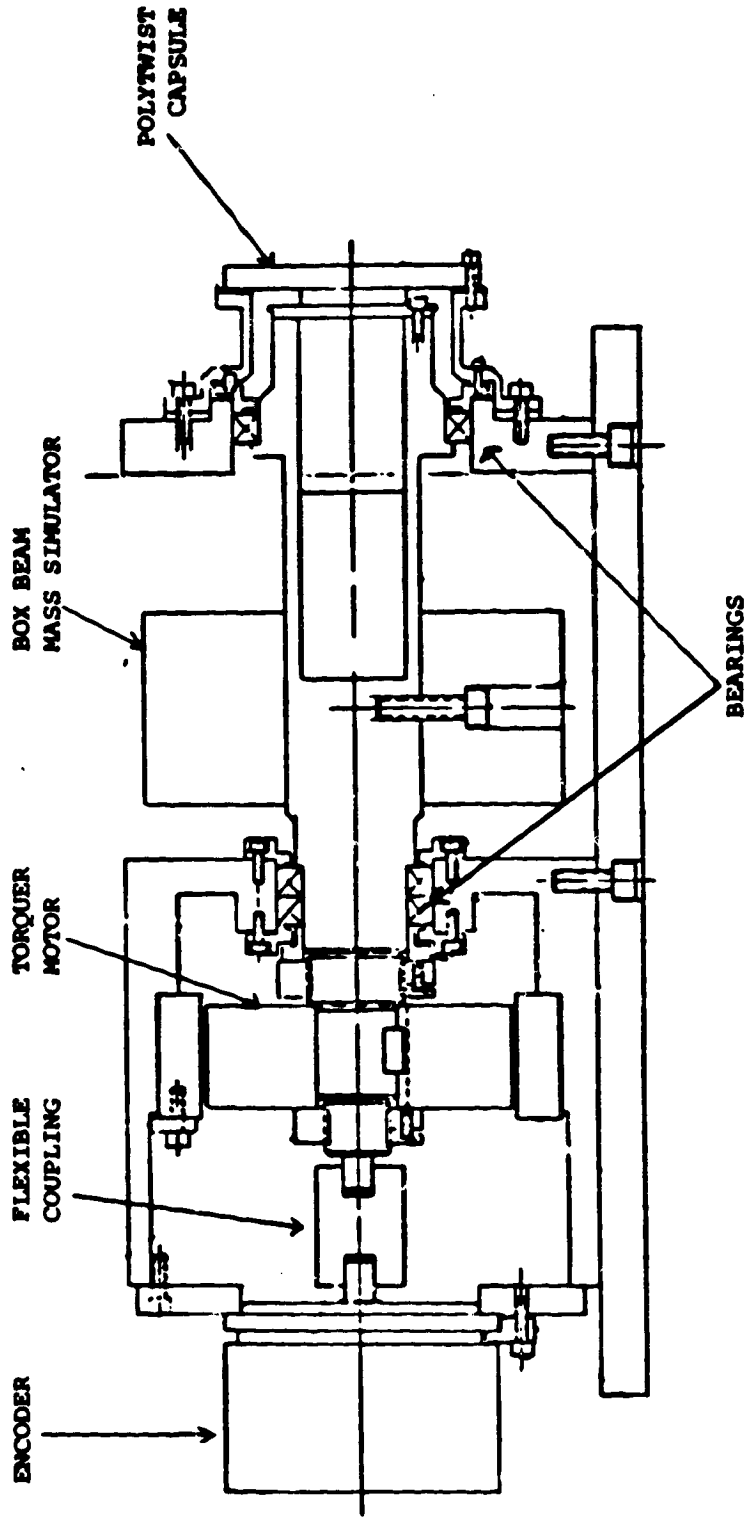

**ERBE — SCANNER ASSEMBLY
LIFE TEST MODEL**

Figure 14

o ANALYSIS OF ERBE SCANNER LTM BALL BEARINGS
ASSEMBLY BY LeRC TRIBOLOGY GROUP

Analysis of ERBE Scanner Ball Bearing Assembly by LeRC Tribology Group

The ERBE Scanner LTM mainframe single bearing was sent to the LeRC for a complete tear-down and analysis by the Tribology group. This group wrote a report documenting the results of this effort. The report is paraphrased here for completeness. The complete report, with data is in the Appendix.

A two part analysis was performed; compound identification of the material on the phenolic retainer and the balls, and a surface elemental analysis of the outer race. A schematic of the Scanner assembly of the life test model is shown in figure 1.

The compound identification analysis was accomplished by first obtaining a high pressure liquid chromatography (HPLC) chromatogram of the unused fluorinated polyether liquid lubricant. This was done by dissolving 30 μ l of the lubricant in 4 ml of 1, 1, 2 trichlorotrifluoroethane (a "Freon" solvent) and injecting 30 μ l into the HPLC unit. All HPLC separations were conducted in the size exclusion mode using an E-125 μ -Bondagel column and a 50A μ -Porasil column. The mobile phase (the 1, 1, 2 trichlorotrifluoroethane solvent) flow rate was maintained at 0.5 ml/min and compound detection made by a refractive index detector.

The phenolic retainer was then soaked, for 15 minutes, in 4 ml of the freon solvent, and 30 μ l of the solution was then analyzed by HPLC. The same procedure was repeated for the ball bearings.

A Fourier transform infrared (FTIR) analysis of the ball bearing extract was also performed.

An analysis of the outer race surface was performed using a scanning electron microscope with an energy dispersive x-ray attachment (EDX). The outer race had small amounts of deposit that seemed to be concentrated in one area of the race. An EDX analysis was performed on an area of the outer race devoid of the deposit, and on the deposit itself.

The HPLC analysis revealed that the freon solvent was able to extract the fluorinated polyester lubricant from the phenolic retainer and that no "detectable" amount of the lubricant was found on the ball bearings. The word "detectable" is used because if the lubricant was present on the ball bearings the amount extracted was too small to be detected by the refractive index detector. Comparison of the FTIR spectra (both identical) also showed no detectable amount of the lubricant was extracted.

The EDX analysis of the outer race revealed nothing unusual. It did indicate chromium, a small amount of carbon and a balance of iron.

The EDX analysis of the deposit, however, revealed small amounts of carbon and oxygen.

The evidence indicates ineffective transfer of the liquid lubricant from the phenolic retainer to the ball bearings. This lack of lubrication between the ball bearings and the races may be due to the TCP treatment. In the high vacuum conditions of outer space, once the metal oxide or phosphate film wears away, there is no oxygen or water vapor to react with the nascent metal surfaces to reform a protective film.

In light of the low vacuum (10^{-3} Torr) used in the scanner life tests, it is possible that the deposit found on the outer race could have resulted from an oxygen reaction at the wearing surfaces.

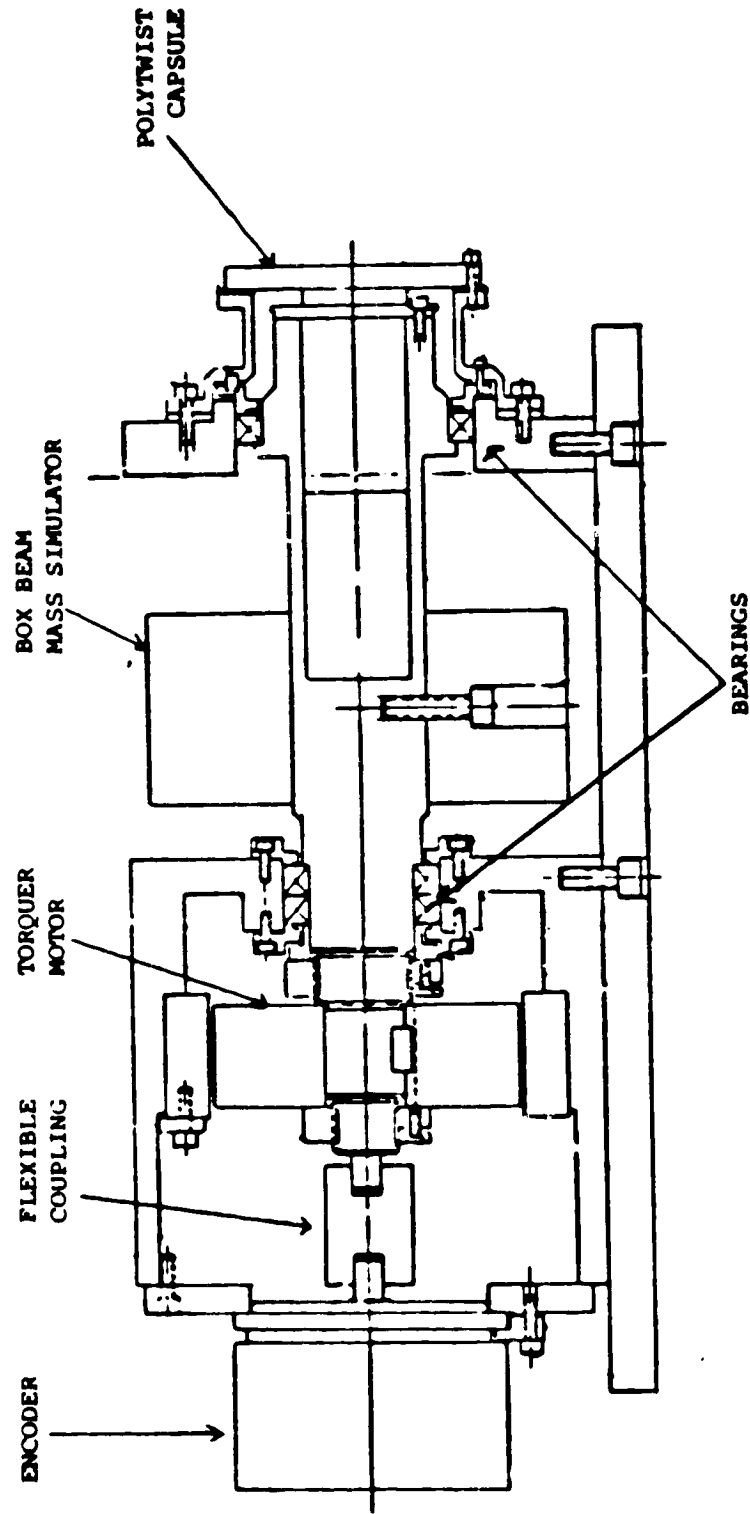

**ERBE -- SCANNER ASSEMBLY
LIFE TEST MODEL**

Figure 1

Conclusions

Although the investigation went into great detail in every area of the instrument's design and operation, the basic conclusions which could be drawn were rather simple. They are:

- (1) In all of the indepth simulations and investigations into the electrical and electronic systems and in the operations of the scanner instruments, the most likely cause of the observed anomalies in both Scanner instruments is the bearing lubrication system. It is also the most plausible possibility which could explain the repeated appearance and disappearance of the sluggish scans based on available data.
- (2) This same anomaly can reasonably be expected to be experienced by the TIROS-G Scanner instrument.
- (3) There is a high probability that the lubrication techniques used on the ERBE Scanner of a saturated phenolic retainer wicking oil onto the balls is improper for the speed (40 rpm maximum) and oscillatory type motion of the bearings. Analysis of the oil film thickness developed through hydrodynamic lubrication by the bearing at its maximum speed and preload indicates the the thickness of the oil does not exceed the bearing race roughness specification. Thus there probably would be a marginal amount of lubrication transferred to the ball/race interface even without the TCP treatment.
- (4) The use of the tricresyl phosphate [TCP] treatment on the bearings, which in itself is somewhat of a lubricant, made the bearings unwettable by the Brayco 815 Z oil. Since TCP is insoluble in the perfluorinated polyether oils, one of which is Brayco 815 Z, it should not be used as an additive to or a surface treatment for bearings to be lubricated with this oil.
- (5) The probability that the temperature rise associated with this anomaly, which was observed in both instruments, resulted from increased bearing friction, and caused the drive motor to operate continuously in the high current mode, is very high.
- (6) The instrument can be operated continuously in this high current mode without the temperatures increasing above the limits already observed or without overstressing the driver or motor components.
- (7) No definite guarantee can be given to the obviously important question of how much life can be expected from these instruments. However, based on the limited operational data base on the anomaly with the current instruments there is a good probability of a full mission success time of 1 year overlap of ERBS and NOAA-9 data being achieved since approximately 7 months of data overlap have already been completed.
- (8) The compromises made during the design, which resulted in very fewer diagnostic data measurements, is a serious impairment to any investigation of this type.

Recommendations

The recommendations deals with the operations of the current ERBE Scanner instruments and also of a more general nature relate to current on-going and future space flight programs which have lubricated systems. The question of what to do with the NOAA-G Scanner, which has not yet been launched, was discussed at length. The final recommendation is to launch NOAA-G with no changes. This recommendation is based on several overriding constraints:

- (1) Based on the current data base of the ERBS and NOAA-9 Scanner instruments and the observed operation of the NOAA-G during testing, a very good probability exists for a full mission success.
- (2) Due to cost and schedule constraints, the choice is to either fly on the NOAA-G as-is, or remove, completely disassemble, correct the lubrication problem and look for a later flight opportunity. Money is not available for this option.

One recommendation of a more general nature is offered for consideration. There is strong evidence that several other space flight programs have experienced anomalies resulting from bearing lubrication problems. There is a relatively large data base on space lubrication which exist in the literature, within industry such as BASD, and within NASA at GSFC and LeRC. Unfortunately there apparently is no publication which combines this data base into a more concise publication for ready reference by system design engineers. Therefore, it is suggested that the Agency generate a reference document for space bearing lubrication on flight programs. This would be analogous to several existing documents such as the pressure vessel design criteria document and the MSFC 522 materials selection document.

The following specific recommendations are offered to correct the type of lubrication problem associated with the ERBE instruments that has been discussed in this report.

- (1) Do not treat the bearings with the tricresyl phosphate (TCP) where a perfluorinated polyether lubricant is to be used, such as Brayco 815Z, since this makes the surface unwettable by this class of lubricants.
- (2) Coat the bearing races with either gold or silver.
- (3) Pack the bearings in a mixture of the Braco 815Z oil and Molybdenum disulfide which has the texture of light grease. The tribology group at LeRC held the opinion that the gold or silver coating alone was sufficient without the grease. However, no one disagreed that adding the grease could only enhance the bearing lubrication. This is a commercially available mixture and meets the outgassing specifications for optical cleanliness.

o APPENDIX

ANALYSIS OF SPACECRAFT INSTRUMENT BALL BEARINGS

FOR

NASA LANGLEY RESEARCH CENTER
HAMPTON, VIRGINIA

BY

WILFREDO MORALES
WILLIAM R. JONES, JR., AND
DONALD H. BUCKLEY

OF

NASA LEWIS RESEARCH CENTER
CLEVELAND, OHIO

INTRODUCTION

The Surface Science Branch (formerly Tribology) of the Lewis Research Center was consulted by Mr. John Cox of the NASA Langley Research Center concerning recent problems involving scanning instruments aboard several satellites.

The instruments, mounted on a ball bearing unit, are rotated by a motor such that the instruments slowly scan back and forth. Apparently, after several months in orbit, a motor torque increase can be detected suggesting an impediment to the free rotation of the instrument. On one occasion the rotation of an instrument stopped completely and a signal had to be sent to the satellite commanding the motor to rotate in the opposite direction thus freeing the instrument.

A scanning life test was conducted in order to determine the probable cause of the motor torque increase. The ball bearing unit used aboard the satellites and in the scanner life test consisted of an inner and outer race, and 34 balls made from 440C stainless steel. A porous phenolic retainer, situated between the races and accommodating the ball bearings was saturated with a fluorinated polyether liquid lubricant; the phenolic retainer was designed as the source of liquid lubricant for the bearings. Both the races and the balls were passivated (by Federal Specification QQ-P-35B) and chemically treated with tricresylphosphate (TCP).

The scanner life test was conducted at room temperature under a vacuum of 10^{-3} Torr. The ball bearing unit had an axial preload of 20 pounds and rotated at 1 revolution per second. Duration of the test was 8.5 million

cycles. At the conclusion of the life test, the ball bearing unit was disassembled and brought to the Surface Science Branch of the NASA Lewis Research Center for analysis.

ANALYSIS

A two part analysis was performed; compound identification of the material on the phenolic retainer and the balls, and a surface elemental analysis of the outer race.

The compound identification analysis was accomplished by first obtaining a high pressure liquid chromatography (HPLC) chromatogram of the unused fluorinated polyether liquid lubricant. This was done by dissolving 30 ul of the lubricant in 4 ml of 1,1,2 trichlorotrifluoroethane (a "Freon" solvent) and injecting 30 ul into the HPLC unit. Figure 1 is the HPLC chromatogram of the unused lubricant. All HPLC separations were conducted in the size exclusion mode using an E-125 μ -Bondagel column and a 60Å μ -Porasil column. The mobile phase (the 1,1,2 trichlorotrifluoroethane solvent) flow rate was maintained at 0.5 ml/min and compound detection made by a refractive index detector.

The phenolic retainer was then soaked, for 15 minutes, in 4 ml of the freon solvent, and 30 ul of the solution was then analyzed by HPLC. Figure 2 represents the HPLC separation of the phenolic retainer extract. The same procedure was repeated for the ball bearings and figure 3 represents the freon extraction from the ball bearings.

Fourier transform infra-red (FTIR) analysis of the ball bearing extract was also performed. Figure 4 is the FTIR spectrum of the pure 1,1,2 trichlorotrifluoroethane solvent and Figure 5 is the FTIR spectrum of the ball bearing extract.

An analysis of the outer race surface was performed using a scanning electron microscope with an energy dispersive x-ray attachment (EDX). The outer race had small amounts of a deposit that seemed to be concentrated in one area of the race. An EDX analysis was performed on an area of the outer race devoid of the deposit, and on the deposit itself.

Figures 6 and 7 are the EDX analysis of the outer race and of the deposit, respectively.

COMMENTS ON THE ANALYSIS

The HPLC analysis revealed that the freon solvent was able to extract the fluorinated polyether lubricant from the phenolic retainer, figure, 3 and that no "detectable" amount of the lubricant was found on the ball bearings, figure 4. The word "detectable" is used because if the lubricant was present on the ball bearings the amount extracted was too small to be detected by the refractive index detector. Comparison of the FTIR spectra (both identical) also showed no detectable amount of the lubricant was extracted.

The EDX analysis of the outer race, figure 5, revealed nothing unusual. It did indicate chromium, a small amount of carbon and a balance of iron.

The EDX analysis of the deposit, figure 6, however, revealed amounts of carbon and oxygen.

CONCLUSIONS

The evidence indicates ineffective transfer of the liquid lubricant from the phenolic retainer to the ball bearings. Any lubrication between the ball bearings and the races may be due to the TCP treatment. In the high vacuum conditions of outer space, once the metal oxide or phosphate film wear away there is no oxygen or water vapor to react with the nascent metal surfaces to reform a protective film.

In light of the low vacuum (10^{-3} Torr) used in the scanner life test, it is possible that the deposit found on the outer race could have resulted from a oxygen reaction at the wearing surfaces.

EDX Analysis was performed by Stephen V. Pepper and Frank Honeycy
of the Surface Science Branch, Materials Division

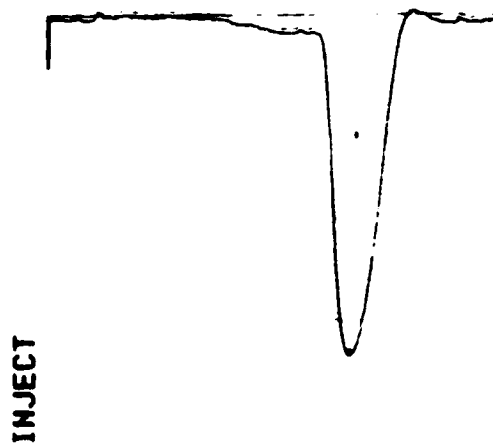

Fig. 1- HPLC chromatogram of the unused fluorocarbon liquid lubricant

INJECT



Fig. 2- HPLC chromatogram of the phenolic retainer extract

INJECT



Fig. 3- HPLC chromatogram of the ball bearing extract

Fig. 4- FTIR spectrum of 1,1,1,2 trichlorotrifluoroethane

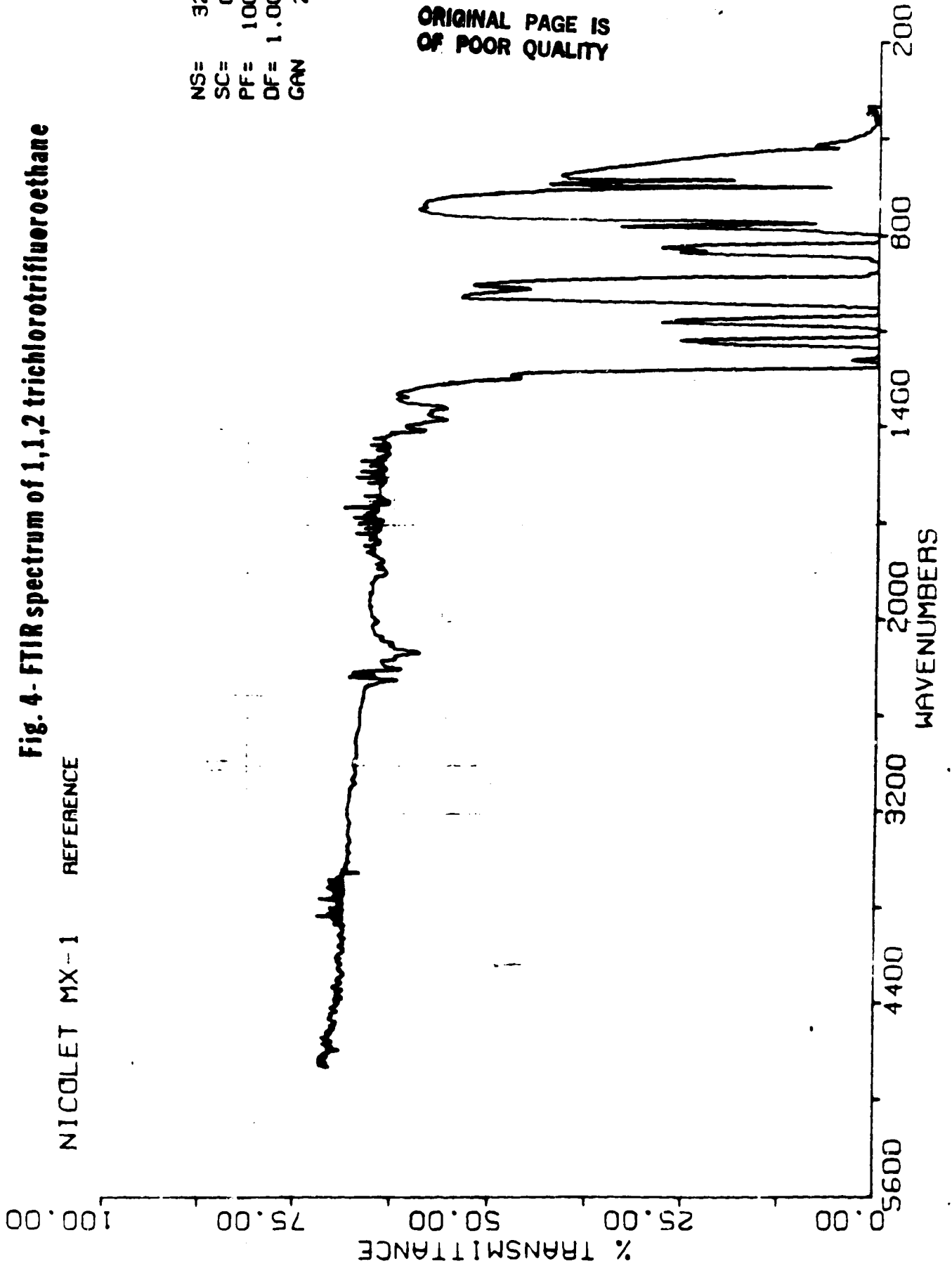
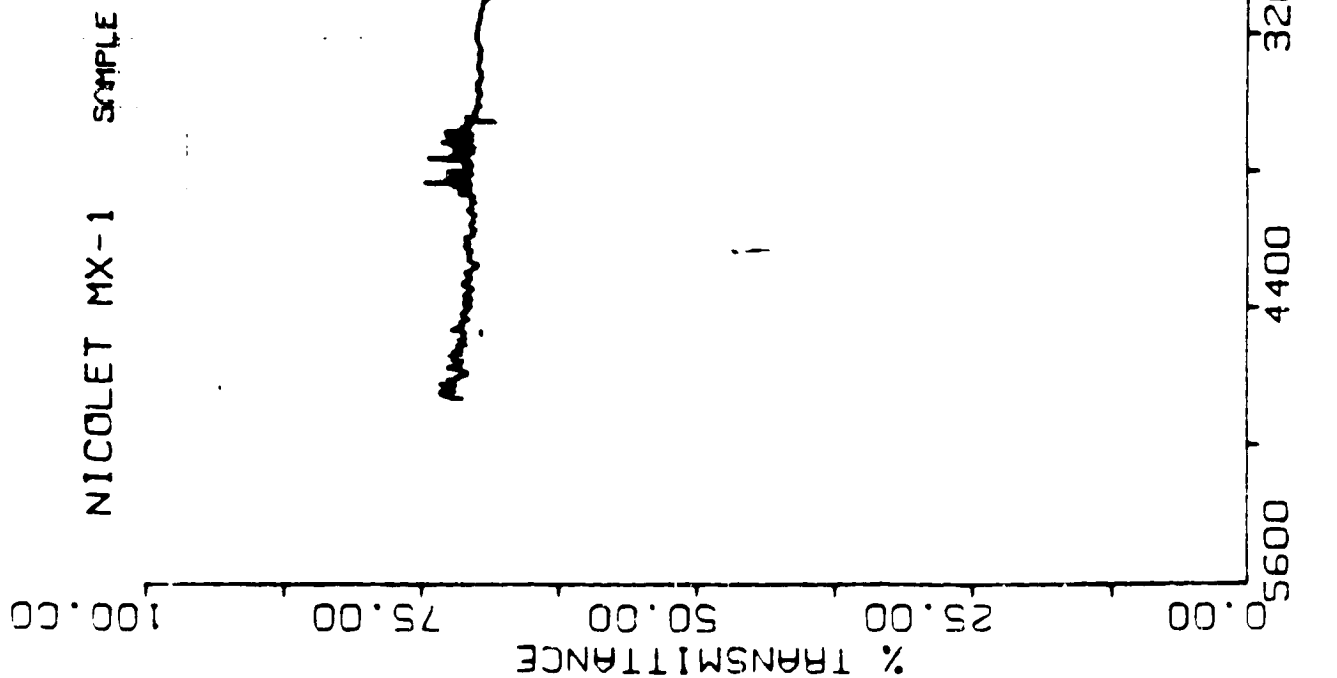

Fig. 5- FTIR spectrum of ball bearing extract



NS= 32
SC= 0
PF= 100
DF= 1.00
GAN 2

ORIGINAL PAGE IS
OF POOR QUALITY

ORIGINAL PAGE IS
OF POOR QUALITY

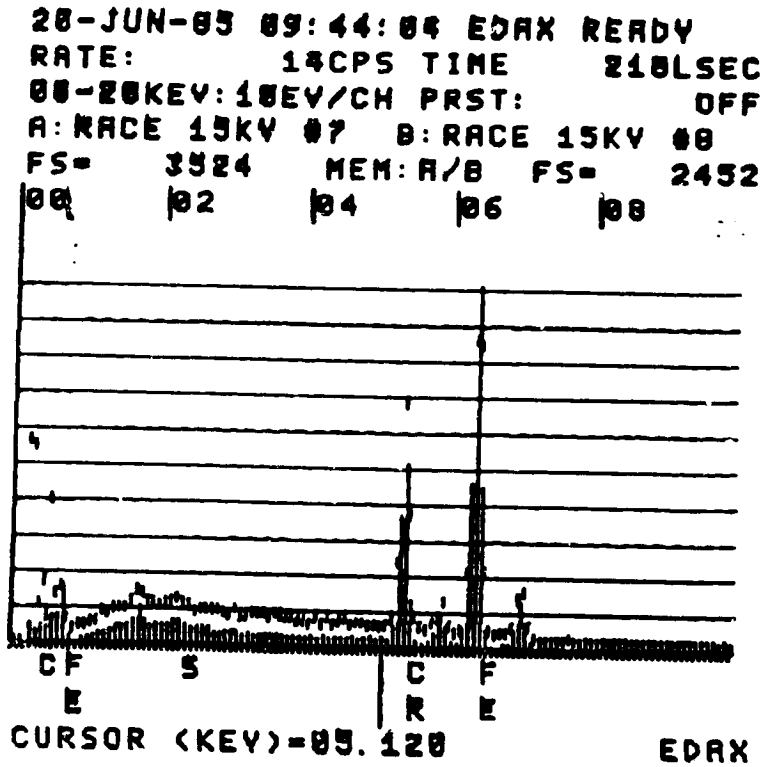

Fig. 6- EDX analysis of outer race

20-JUN-85 09:44:44 EDAX READY
RATE: 12CPS TIME 210LSEC
00-20KEY: 10EV/CH PRST: OFF
A: RACE 15KV 07 B: RACE 15KV 08
FS= 3924 MEM: A/B FS= 2452
01 02

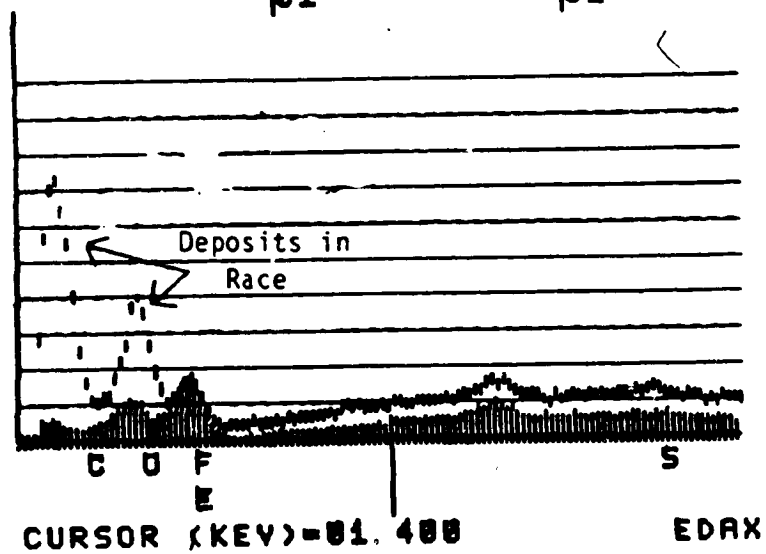

Fig. 7- EDX analysis of deposit

Standard Bibliographic Page

1. Report No. NASA TM-87636		2. Government Accession No.		3. Recipient's Catalog No.	
4. Title and Subtitle Earth Radiation Budget Experiment (ERBE) Scanner Instrument Anomaly Investigation				5. Report Date October 1985	
				6. Performing Organization Code 619-12-01-01	
7. Author(s) N. D. Watson, J. B. Miller, L. V. Taylor, J. B. Lovell, J. W. Cox, J. C. Fedors, L. P. Kopia, R. M. Holloway, and O. H. Bradley				8. Performing Organization Report No.	
				10. Work Unit No.	
9. Performing Organization Name and Address NASA Langley Research Center Hampton, VA 23665-5225				11. Contract or Grant No.	
				13. Type of Report and Period Covered Technical Memorandum	
12. Sponsoring Agency Name and Address National Aeronautics and Space Administration Washington, DC 20546				14. Sponsoring Agency Code	
				15. Supplementary Notes	
16. Abstract The results of an ad-hoc committee investigation of in-Earth orbit operational anomalies noted on two identical Earth Radiation Budget Experiment (ERBE) Scanner instruments on two different spacecraft busses, is presented. The anomalies are attributed to the bearings and the lubrication scheme for the bearings. A detailed discussion of the pertinent instrument operations, the approach of the investigation team and the current status of the instruments now in Earth orbit is included. The team considered operational changes for these instruments, rework possibilities for the one instrument which is waiting to be launched, and preferable lubrication considerations for specific space operational requirements similar to those for the ERBE scanner bearings.					
17. Key Words (Suggested by Author(s)) Space Bearings Lubrication			18. Distribution Statement Unclassified - Unlimited Subject Category 35		
19. Security Classif (of this report) Unclassified		20. Security Classif (of this page) Unclassified		21. No. of Pages 86	22. Price A05

For sale by the National Technical Information Service, Springfield, Virginia 22161

END

DATE

FILMED

MAR 13 1986