

NASA Technical Memorandum 87214

Simplified Cyclic Structural Analyses of SSME Turbine Blades

(NASA-TN-87214) SIMPLIFIED CYCLIC
STRUCTURAL ANALYSES OF SSME TURBINE BLADES
(NASA) 17 p HC A02/MF A01 CSCL 20K

N86-16615

G3/39 Unclas
05290

A. Kaufman and J.M. Manderscheid
Lewis Research Center
Cleveland, Ohio

Prepared for the
Conference on Advanced High Pressure Oxygen/Hydrogen
Propulsion Technology
sponsored by NASA Marshall Space Flight Center
Huntsville, Alabama, May 14-16, 1986

NASA



SIMPLIFIED CYCLIC STRUCTURAL ANALYSES OF SSME TURBINE BLADES

A. Kaufman and J.M. Manderscheid
National Aeronautics and Space Administration
Lewis Research Center
Cleveland, Ohio 44135

SUMMARY

Anisotropic high-temperature alloys are used to meet the safety and durability requirements of turbine blades for high-pressure turbopumps in reusable space propulsion systems. This study assesses the applicability to anisotropic components of a simplified inelastic structural analysis procedure developed at the NASA Lewis Research Center. The procedure uses as input the history of the total strain at the critical crack initiation location computed from elastic finite-element analyses. Cyclic heat transfer and structural analyses were performed for the first stage high-pressure fuel turbopump blade of the space shuttle main engine. The blade alloy is directionally solidified MAR-M 246 (nickel base). The analyses were based on a typical test stand engine cycle. Stress-strain histories for the airfoil critical location were computed using both the MARC nonlinear finite-element computer code and the simplified procedure. Additional cases were analyzed in which the material yield strength was arbitrarily reduced to increase the plastic strains and, therefore, the severity of the problem. Good agreement was shown between the predicted stress-strain solutions from the two methods. The simplified analysis used about 0.02 percent (5 percent with the required elastic finite-element analyses) of the CPU time used by the nonlinear finite element analysis.

INTRODUCTION

Hot gas-path components of advanced aircraft gas turbine engines and rocket engines for reusable space propulsion systems operate under extreme gas pressure and temperature environments. These operating conditions subject the high-pressure stage turbine nozzles and blades to severe thermal transients that can result in large inelastic strains and rapid crack initiation. To attain the safety and durability requirements for these components frequently necessitates the use of advanced turbine blading alloys. These alloys exhibit mechanical property anisotropy. Assessing or improving the durability of hot section components is contingent on accurate knowledge of the stress-strain history at the critical location for crack initiation.

Nonlinear finite-element analysis techniques have become available in recent years for calculating inelastic structural response under cyclic loading. These methods are based on classical incremental plasticity theory with uncoupled creep constitutive models. Many of the nonlinear finite-element computer codes such as MARC (ref. 1) have the capability of handling materials with anisotropic properties. However, these codes are usually too costly and time consuming to use in the early design stages for aerospace applications. Costs are further increased by the geometrical complexity of high-pressure turbine blades which require three-dimensional analyses and sometimes substructuring to obtain accurate solutions. To improve the design of engine hot path

components such as turbine blades, simplified and more economical procedures for representing structural response under cyclic loading have been under development (refs. 2 to 4).

The objective of this study was to evaluate the utility of a simplified cyclic structural analysis method in calculating the local stress-strain response of an anisotropic turbine blade airfoil at the critical location for crack initiation. The first high-pressure stage fuel turbine blade (HPFTB) in the liquid hydrogen turbopump of the space shuttle main engine (SSME) was selected for this study. In the past these blades have undergone cracking in the blade shank region and at the airfoil leading edge adjacent to the platform. To achieve the necessary durability, these blades are currently being cast using directional solidification. Single crystal alloys are also under investigation for future SSME applications. MARC elastic and elastic-plastic finite-element analyses were performed for the blade airfoil. Because of the extensive computation time required for the nonlinear finite-element analyses, neither the blade platform nor shank regions were modeled. The history of the total strain calculated at the critical location from the elastic finite-element analysis was used as input for the simplified procedure. Solutions from the simplified inelastic analyses of these problems for the critical airfoil location were compared to those from the MARC nonlinear analyses.

PROBLEM DESCRIPTION

The airfoil of the high pressure stage turbine blade of the SSME fuel turbopump was analyzed because of its history of early crack initiation. This blade is illustrated in figure 1. The uncooled airfoils have a span length of 2.2 cm and a span-to-chord width aspect ratio of approximately unity. The blades are directionally cast from MAR-M 246+Hf alloy. Temperature-dependent properties for this alloy were mainly provided by the Rocketdyne Division of Rockwell International Corporation. Material elastic properties are summarized in table I. Mean thermal coefficient of expansion data were converted to instantaneous values for MARC input. Longitudinal stress-strain properties, summarized in table II, were used for the elastic-plastic region; transverse stress-strain properties were not available at the time of this study. A single crystal alloy is also being considered for turbine blades in future SSME applications.

Cracking has occurred during service at the airfoil base near the leading edge and in the blade root shank area. These cracks were apparently initiated during the first few mission cycles due to the severe thermal transients and were propagated by vibratory excitation. Since the primary purpose of this study was to compare nonlinear finite-element and simplified analytical methods, the blade root and platform were excluded from the analysis to limit the size of the problem and, therefore, reduce the computing time.

The mission used for the analysis is shown in figure 2 in terms of turbine inlet temperature, gas pressure and RPM. This cycle is applicable to a factory test of the engine; it is also reasonably representative of a flight mission except for the foreshortened steady-state operating time. The major factor inducing fatigue cracking is the transient thermal stresses caused by the sharp ignition and shutoff transients.

Transient and steady-state three dimensional heat transfer analyses have been conducted using the MARC code. Film coefficients were obtained from preliminary information supplied by Rocketdyne. The gas temperature was assumed constant around the airfoil surface for each time step. Colder boundary conditions were assumed at the airfoil base to simulate the effects of the cooling of the blade-to-disk attachment region by the liquid hydrogen fuel.

ANALYTICAL PROCEDURE

Elastic-plastic analyses have been conducted for the HPFTB airfoil with both a simplified analytical procedure developed at the NASA Lewis Research Center and with the MARC code. The severity of the problem was progressively increased by analyzing a series of cases in which the material yield strength was arbitrarily reduced until plastic strain reversal was obtained in the cycle. Separate MARC analyses were conducted for one case using both orthotropic elastic constants and the Young's modulus and Poisson's coefficient with respect to the longitudinal (spanwise) direction; this was to determine if the longitudinal properties would give a sufficiently accurate elastic-plastic finite-element solution to be used for the simplified analysis. However, the best results were obtained with the simplified procedure by the use of effective elastic moduli based on MARC elastic finite-element analyses with orthotropic material properties. Creep analyses were not conducted because the combination of airfoil temperatures and mission dwell times were not severe enough to induce a significant creep problem. Also, there was inadequate knowledge of the creep characteristics of the anisotropic material to perform such analyses even if desired.

Simplified Analysis

The simplified analytical procedure was developed to economically calculate the stress-strain history at the critical fatigue location of a structure subjected to cyclic thermomechanical loading. This procedure has been exercised on a wide variety of problems including multiaxial loading, nonisothermal conditions, different materials and constitutive models, and dwell times at various points in the cycles. Comparisons of the results of the simplified analyses with MARC inelastic solutions for these problems have shown reasonably good agreement (refs. 2 to 4).

The basic assumption is that the total strain ranges calculated from linear elastic and nonlinear inelastic analyses are approximately equal and, therefore, the material cyclic response can be calculated using as input the total strain history obtained from an elastic analysis. This assumption is essentially true for thermally dominated loading. There is a version of the procedure that uses Neuber-type corrections to account for strain redistribution due to mechanical loading; however, this version was not utilized for this study because of the dominance of the thermal loading during the peak strain parts of the cycle. Classical incremental plasticity methods are used to characterize the yield surface by a yield condition to describe yielding under multiaxial stress states and by a hardening model to establish the location of the yield surface during cycling. This procedure can accommodate itself to any yield criterion or hardening model. The only requirements are that the elastic input data, whether calculated or measured, be in a form

consistent with the yield criterion and that the appropriate material properties be used in conjunction with the hardening model.

In these analyses, a bilinear kinematic hardening model was used to represent the effect of cycling on the yield condition. Since the cyclic stress-strain relation is a function of the plastic strain range, it is necessary to iterate between the initially assumed and the calculated maximum plastic strains. This iterative process is usually accomplished within three iterations. However, each iteration results in some change in the size and shape of the cyclic stress-strain loop. These changes, although generally small, create some difficulty in directly comparing solutions from the simplified procedure against finite-element analysis results because of the differences in the stress-strain curves.

As in most nonlinear computer codes, the von Mises yield criterion has been used in applying stress-strain results from elastic finite-element analyses of multiaxial problems as input for the simplified procedure. To compute cyclic hysteresis loops for life prediction purposes, the input von Mises stresses and strains have to be assigned signs, usually on the basis of the signs of the dominant principal stresses and strains.

The elastic input data are subdivided into a sufficient number of increments to define the stress-strain cycle. As will be discussed later, elastic finite-element solutions for 6 points in the SSME mission cycle proved adequate as the basis to create the total strain history required as input for the simplified analysis of the HPFTB airfoil. These points were at the start and end of the mission and at the maximum and minimum temperature peaks during the preignition and main ignition phases. A total of 120 stress-strain-temperature-time increments were obtained by interpolation from the 6 elastic finite-element solutions for the critical location. These increments are analyzed sequentially to obtain the cumulative plastic and creep strains and to track the yield surface.

An iterative procedure is used to calculate the yield stresses for increments undergoing plastic straining. First, an estimated plastic strain is assumed for calculating an initial yield stress from the stress-strain properties and the simulated hardening model. Then a new plastic strain is calculated as the difference between the total and elastic and creep strain components. The yield stress is then recalculated using the new plastic strain. This iterative procedure is repeated until the new and previous plastic strains agree within a tolerance of 1 percent. Creep computations are performed for increments involving dwell times using the creep characteristics incorporated in the code. Depending on the nature of the problem, the creep effects are determined on the basis of one of three options to be selected; (1) stress relaxation at constant strain, (2) cumulative creep at constant stress, or (3) a combination of (1) and (2).

A FORTRAN IV computer program (ANSYMP) was created to automatically implement the simplified analytical procedure. A detailed description of the calculational scheme is presented in previous papers (refs. 2 to 4) on the development of this procedure.

MARC Finite-Element Analysis

A three-dimensional finite-element model of the airfoil (fig. 3) was constructed of eight-node isoparametric elements. The model consisted of 360 elements with 576 nodes and 1661 unsuppressed degrees of freedom. The blade base and most of the platform were omitted for the MARC nonlinear analysis to reduce the computing time and to run the problem in-core on the CRAY computer system at Lewis. Boundary conditions were applied to constrain all nodes at the base of the model to lie on a platform plane. Additional boundary conditions were imposed to prevent rigid body motion in this plane.

The MARC code has been used extensively at NASA Lewis for inelastic analyses of aircraft turbine blades and combustor liners and of space power components. In conducting a cyclic analysis, the loading history is divided into a series of incremental load steps which are sequentially analyzed. The plasticity algorithm is based on a tangent stiffness approach in which the stiffness matrix is reformulated and reassembled for every plastic load increment. The incremental loads are modified by residual load correction vectors to insure that the solution does not drift from a state of equilibrium. Convergence for the iterative plasticity analysis is indicated when the strain energy used in assembling the stiffness matrix approximately equals the energy change resulting from the incremental solution.

The temperature tolerance controls on the MARC transient heat transfer analysis resulted in the automatic subdivision of the mission cycle into 124 time increments. The same increments were used for the elastic-plastic structural analyses. Incremental loading included centrifugal and gas pressure loads and metal temperature distributions as calculated from the heat transfer analysis. Approximately one million words of core storage on a CRAY-1S computer were needed to run the problem. Each cycle of analysis required about 3 hr of central processor unit (CPU) time on the CRAY system. In terms of calendar time, the situation was even more serious because the system was so heavily loaded that such a large block of computing time normally was only available over weekends.

The directionality of the elastic material properties causes anisotropic constraints. Lekhnitskii (ref. 5) has derived the generalized elastic strain equations for an anisotropic body with a transverse plane of isotropy. Matrix inversion of these equations to solve for the stresses results in the relationship

$$\begin{bmatrix} \sigma_x \\ \sigma_y \\ \sigma_z \\ \tau_{yz} \\ \tau_{xz} \\ \tau_{xy} \end{bmatrix} = a \begin{bmatrix} (1 - \nu\nu'^2) & (\nu + \nu\nu'^2) & \nu'(1 + \nu) & 0 & 0 & 0 \\ (\nu + \nu\nu'^2) & (1 - \nu\nu'^2) & \nu'(1 + \nu) & 0 & 0 & 0 \\ \nu'(1 + \nu) & \nu'(1 + \nu) & (1 - \nu^2)/\nu & 0 & 0 & 0 \\ 0 & 0 & 0 & G'/a & 0 & 0 \\ 0 & 0 & 0 & 0 & G'/a & 0 \\ 0 & 0 & 0 & 0 & 0 & G/a \end{bmatrix} \begin{bmatrix} \epsilon_x \\ \epsilon_y \\ \epsilon_z \\ \gamma_{yz} \\ \gamma_{xz} \\ \gamma_{xy} \end{bmatrix}$$

where $n = E/E'$ and $a = nE'/((1 + \nu)(1 - \nu - 2n\nu'^2))$. Here E' , G' , and ν' denote the Young's modulus, shear modulus and Poisson's ratio, respectively, for the longitudinal or span direction while E , G , and ν denote these constants with respect to any direction in the transverse plane of isotropy. Rocketdyne supplied values of 0.143 and 0.391 were used for ν' and ν , respectively. This anisotropic stress-strain law was incorporated in the MARC user subroutine, HOOKLW.

Plastic strain calculations were based on incremental plasticity theory using the von Mises yield criterion, the normality flow rule and a kinematic hardening model. The material elastic-plastic behavior was specified by the yield strengths and work hardening properties in the longitudinal direction; transverse properties were not available.

DISCUSSION OF RESULTS

Calculated metal temperatures at the leading edge at midspan and at the crack initiation site at the base of the airfoil (critical location) are presented in figure 4 as a function of elapsed time during the cycle. The assumed gas temperature around the airfoil is also indicated. Of particular note is that the leading edge temperature at the airfoil base is cooler than at midspan throughout the cycle. This seems reasonable because of the cooling of the blade-to-disk attachment region by the liquid hydrogen fuel. The colder airfoil base temperatures induce tensile thermal stresses at the critical leading edge location that are additive to the centrifugal stresses.

The entire discussion of the structural analysis results for the HPFTB airfoil presented herein will be based on the critical location at the leading edge adjacent to the platform as indicated in figure 1, unless otherwise indicated. This location was established from the finite element analysis by determining the Gaussian point which exhibited the largest total strain change during a mission cycle. There was some practical difficulty in determining this location because of the large number of elements, Gaussian integration points and load-time increments involved and the consequent need to survey a vast amount of computer output printout.

A number of cases were analyzed in which the material yield strength was progressively and arbitrarily reduced to increase the severity of the plastic strain until reversed plasticity was induced. Comparisons are made between the stress-strain cycles computed from the simplified and MARC finite-element analyses. The comparisons are limited to the first mission cycle because of the exorbitant computing time required for the nonlinear finite-element analysis. As mentioned previously, creep analyses were not performed because the dwell times were too short for the temperatures involved to have significant creep strains and the creep properties of the material were not adequately defined.

Since the simplified procedure is basically uniaxial, it can not directly account for material anisotropy. The most convenient assumption to have made was that the anisotropic effects could be neglected and the stress-strain history approximated by using only the longitudinal properties. However, the questionableness of this assumption is indicated in figure 5 which shows the difference in the computed stress-strain cycles between finite-element analyses using anisotropic and only longitudinal material properties. The results

presented in figure 5 were from MARC elastic-plastic analyses of the HPFTB airfoil in which the material yield strength was deliberately reduced for analytical purposes to increase the severity of the cycle. The stress-strain hysteresis loops in figure 5 were for a different Gaussian integration point than was subsequently determined as being the critical location based on the maximum cyclical total strain range criterion.

The MARC stress-strain cycle calculated from the orthotropic properties of the directionally solidified MAR-M 246 alloy is shown in figure 6. All of the plastic strain occurred during heatup on the preignition part of the mission. The calculated plastic strain was small (under 300 microstrain) and confined to a local region at the leading edge. Initially, MARC elastic analyses were conducted for all 124 cycle load-time increments used in the elastic-plastic analysis. Effective elastic moduli were obtained throughout the cycle from the computed effective elastic stresses and total strains. The simplified procedure was modified to use these effective elastic moduli to simulate the effects of the material anisotropy. Using this approximation, very good agreement was obtained between the MARC and simplified analytical cycles as shown in figure 6(a).

The problem was then rerun using only six elastic finite-element solutions as input for the simplified analysis. These solutions were for the start and end points of the mission cycle and for the minimum and maximum temperature points during preignition and ignition. To establish a more complete history of total strain, another 114 load-time increments were obtained by interpolation from the initial elastic solutions. The computed stress-strain cycle from the simplified analysis using the reduced number of elastic solutions also shows reasonably good agreement with the MARC cycle (fig. 6(b)), although not quite as good as when the larger number of elastic finite-element solutions was used as input. A noticeable discrepancy is seen in the compressive strain region where the reduction in elastic analysis points resulted in failure to capture some of the cycle fluctuation due to transient thermal effects during the rapid engine cooldown. The CPU time for the six elastic finite-element analyses amounted to 5 percent of that required for one cycle of the nonlinear finite-element analysis.

To increase the severity of the problem, a series of analytical cases were run in which the material yield strength was arbitrarily and progressively reduced until the occurrence of plastic strain reversal on the unloading part of the cycle. The maximum plastic strain for this case was over 5000 microstrain. Calculated stress-strain cycles from the two analytical methods are compared in figure 7. The same history of total strain as was created previously from the 6 elastic finite-element solutions was used as input for the simplified analysis for this case. The simplified analysis cycle in figure 7 showed reasonably good agreement with the MARC results. Again the exception was a low stress region during unloading where the severe thermal fluctuations due to cooldown were not fully taken into account with the reduced number of elastic analyses. However, the region of the cycle where this discrepancy occurred was elastic and would not have a significant effect on life prediction based on the calculated stress-strain response. The stress-strain cycle predicted from the simplified method provided the stress/strain ranges and mean stress values normally needed for life prediction purposes to almost the same degree of accuracy as the nonlinear finite-element analysis. The CPU time per cycle for the simplified analysis was less than 0.01 percent of that required for the MARC elastic-plastic analysis.

SUMMARY OF RESULTS

A simplified inelastic procedure for calculating the local stress-strain history in a thermomechanically cycled structure was further developed to handle material anisotropy. This was accomplished by the use of effective elastic moduli that were determined from anisotropic finite-element analyses for a number of points in the mission cycle. The simplified analysis was exercised on airfoil problems for the first-stage high-pressure fuel turbopump blade of the space shuttle main engine. Predicted stress-strain cycles for the critical airfoil location were compared to stress-strain cycles computed from elastic-plastic finite-element analyses using the MARC code. The following general conclusions were drawn from the evaluation of the improved simplified procedure:

1. The stress-strain response predicted from the simplified analysis was generally in very good agreement with the elastic-plastic finite-element solutions. The predicted stress-strain cycles provided the basic information normally needed for life prediction, such as stress and strain ranges and mean stress, to almost the same degree of accuracy as the finite-element analysis.

2. Limiting the elastic finite-element analyses to several key points in the mission cycle and interpolating between these solutions to create a more complete history of total strain, resulted in some inaccuracy in intermediate parts of the cycle due to the neglect of transient thermal fluctuations during the engine cooldown phase. However, the region where this discrepancy occurred was elastic and would not significantly affect the accuracy of life predictions based on the calculated local stress-strain response.

3. The simplified procedure computed the stress-strain history at the critical location of the structure using about 0.01 percent of the CPU time required for MARC elastic-plastic finite-element analyses. There was an overhead computing cost for conducting elastic finite-element analyses of key points in the mission to define the input total strain history. This additional cost amounted to about 5 percent of the CPU time used in just one cycle of the MARC analyses.

REFERENCES

1. MARC General Purpose Finite Element Program. Vol. A: User Information Manual; Vol. B: MARC Element Library. MARC Analysis Research Corporation, 1980.
2. Kaufman, A.: A Simplified Method for Elastic-Plastic-Creep Structural Analysis. J. Eng. Gas Turbines Power, vol. 107, no. 1, Jan. 1985, pp. 231-237.
3. Kaufman, A.: Development of a Simplified Procedure for Cyclic Structural Analysis. NASA TP-2243, 1984.

4. Kaufman, A.; and Hwang, S.Y.: Local Strain Redistribution Corrections for a Simplified Inelastic Analysis Procedure Based on an Elastic Finite-Element Analysis. NASA TP-2421, 1985.
5. Lekhnitskii, S.G., and Brandstatter, J.J., eds.: Theory of Elasticity of an Anisotropic Elastic Body. Holden-Day, Inc., 1963., pp. 24-25.

TABLE I. - DS MAR-M 246 PHYSICAL PROPERTIES

Temperature, C	Modulus of elasticity, GPa		Mean coefficient of Thermal expansion, %/C
	Longitudinal	Transverse	
21	131	183	-----
93	128	179	0.00113
204	125	175	.00130
316	124	173	.00133
427	119	166	.00141
538	114	162	.00148
649	109	156	.00149
760	103	149	.00156
871	97	142	.00160

TABLE II. - DS MAR-M 246 STRESS-STRAIN
PROPERTIES (LONGITUDINAL)

Plastic strain, %	Stress, MPa		
	21 °C	649 °C	816 °C
0.1	800	808	875
.2	830	855	930
.4	850	895	965
.6	855	930	970
.8	865	945	975
1.0	870	960	980

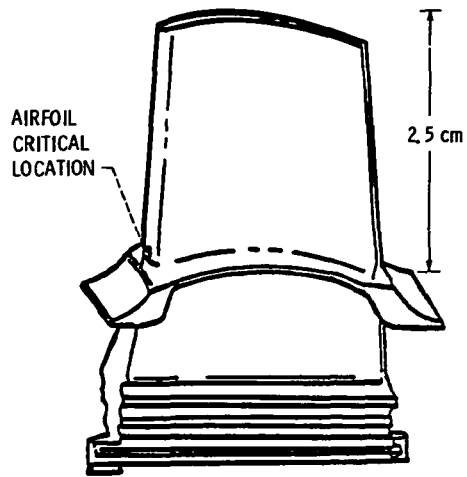
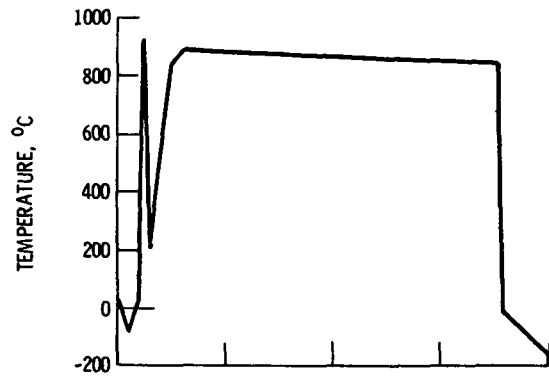
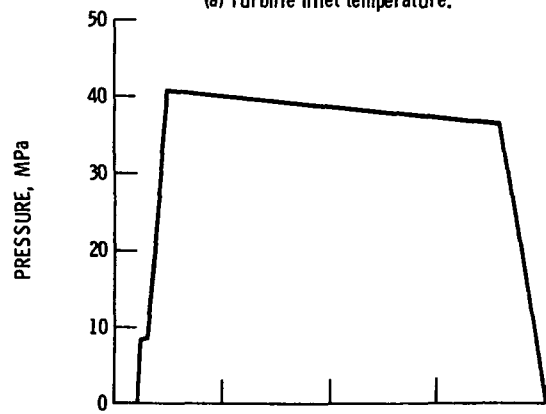

Figure 1. - SSME high-pressure fuel turbo-pump 1st stage turbine blade.



(a) Turbine inlet temperature.



(b) Turbine inlet pressure.

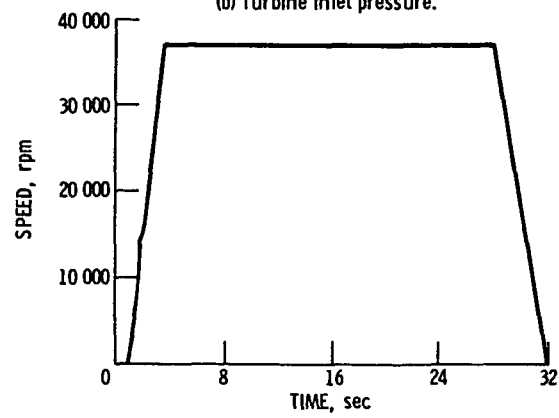

(c) Blade rotational speed.

Figure 2 - Mission cycle used for analysis.

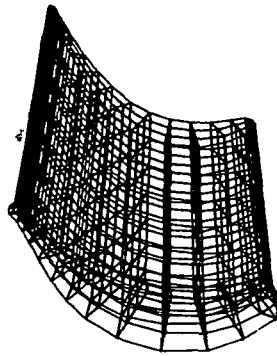

Figure 3 - Airfoil finite element model.

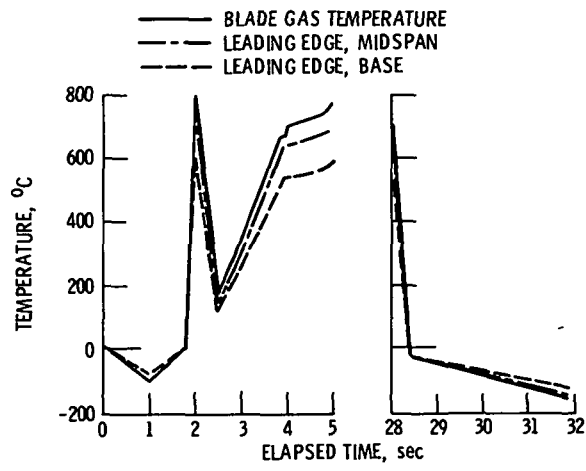

Figure 4 - Airfoil temperature cycle.

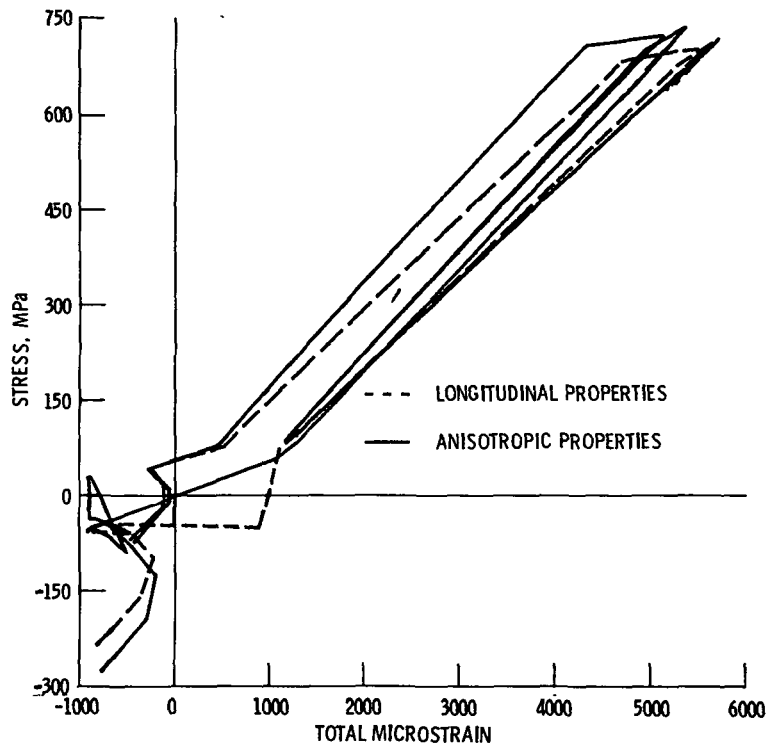
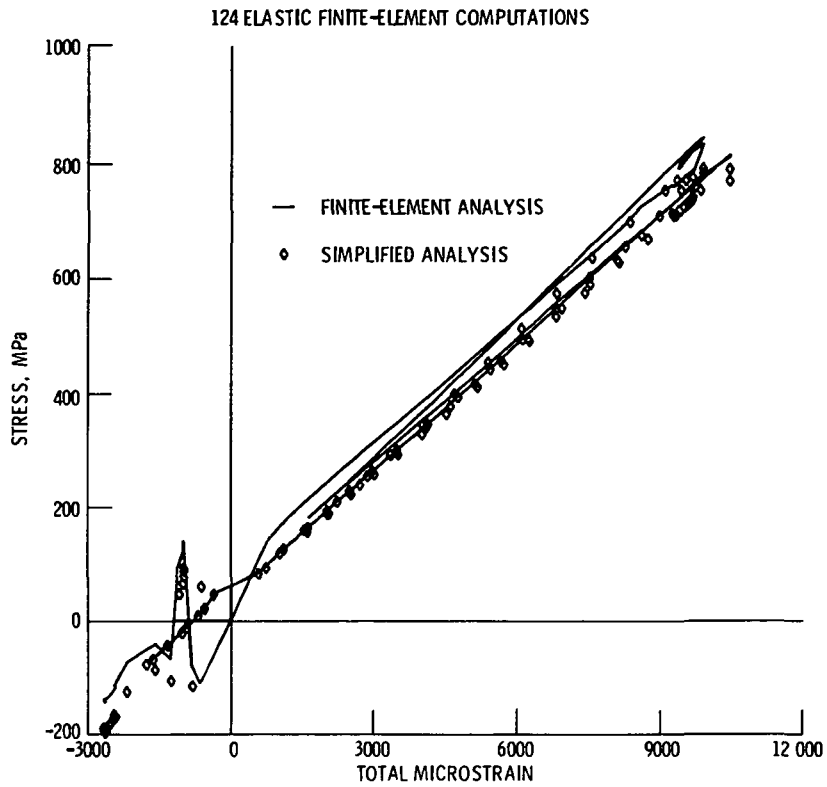
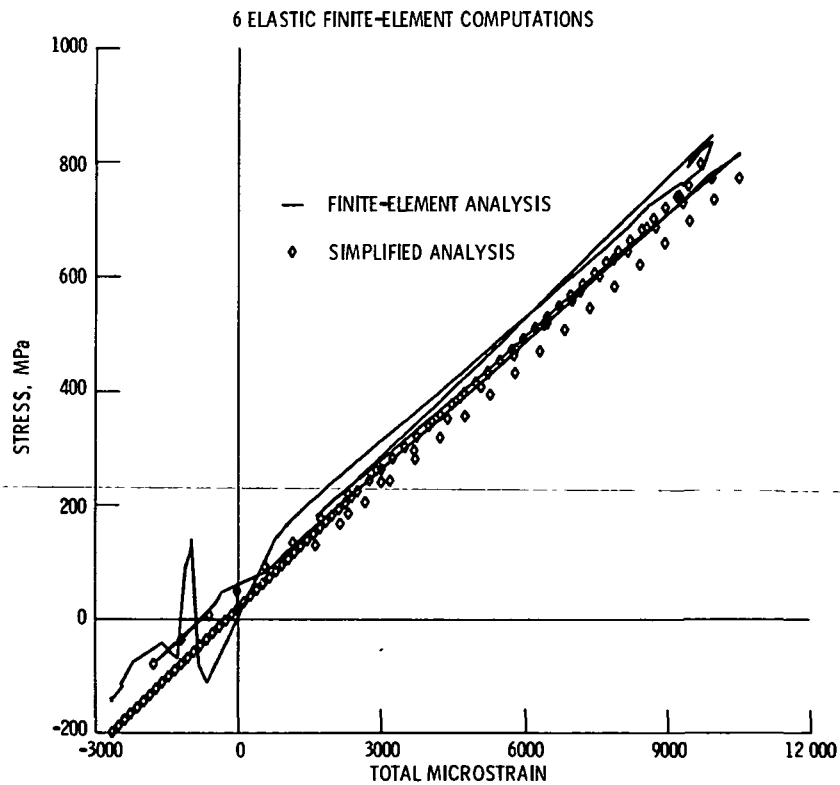

Figure 5. - Comparison of Marc stress-strain cycles for critical location using anisotropic and longitudinal material properties.



(a) 124 Elastic finite-element computations.

Figure 6. - Comparison of simplified and Marc stress-strain cycles at critical location using DS Mar-M246 properties.



(b) 6 Elastic finite-element computations.

Figure 6. - Concluded.

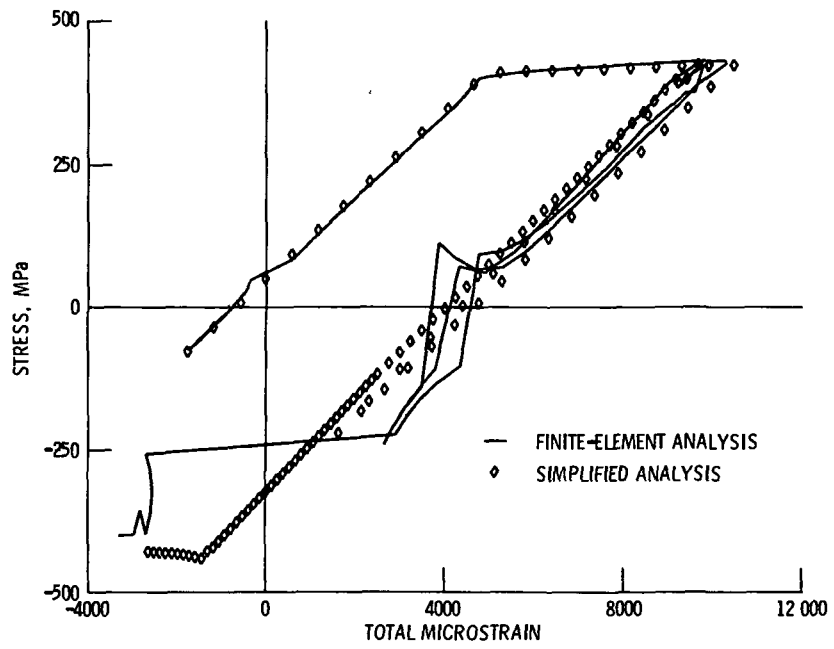

Figure 7. - Comparison of simplified and Marc stress-strain cycles at critical location using reduced yield strength.

1 Report No NASA TM-87214		2 Government Accession No		3 Recipient's Catalog No	
4 Title and Subtitle Simplified Cyclic Structural Analyses of SSME Turbine Blades				5 Report Date	
				6 Performing Organization Code 506-60-12	
7 Author(s) A. Kaufman and J.M. Manderscheid				8 Performing Organization Report No E-2873	
				10 Work Unit No	
9 Performing Organization Name and Address National Aeronautics and Space Administration Lewis Research Center Cleveland, Ohio 44135				11 Contract or Grant No	
				13 Type of Report and Period Covered Technical Memorandum	
12 Sponsoring Agency Name and Address National Aeronautics and Space Administration Washington, D.C. 20546				14 Sponsoring Agency Code	
15 Supplementary Notes Prepared for the Conference on Advanced High Pressure Oxygen/Hydrogen Propulsion Technology, sponsored by NASA Marshall Space Flight Center, Huntsville, Alabama, May 14-16, 1986.					
16 Abstract Anisotropic high-temperature alloys are used to meet the safety and durability requirements of turbine blades for high-pressure turbopumps in reusable space propulsion systems. This study assesses the applicability to anisotropic components of a simplified inelastic structural analysis procedure developed at the NASA Lewis Research Center. The procedure uses as input the history of the total strain at the critical crack initiation location computed from elastic finite-element analyses. Cyclic heat transfer and structural analyses were performed for the first stage high-pressure fuel turbopump blade of the space shuttle main engine. The blade alloy is directionally solidified MAR-M 246 (nickel base). The analyses were based on a typical test stand engine cycle. Stress-strain histories for the airfoil critical location were computed using both the MARC nonlinear finite-element computer code and the simplified procedure. Additional cases were analyzed in which the material yield strength was arbitrarily reduced to increase the plastic strains and, therefore, the severity of the problem. Good agreement was shown between the predicted stress-strain solutions from the two methods. The simplified analysis used about 0.02 percent (5 percent with the required elastic finite-element analyses) of the CPU time used by the nonlinear finite-element analysis.					
17 Key Words (Suggested by Author(s)) Nonlinear structural analysis; Space shuttle; Turbine blades			18 Distribution Statement Unclassified - unlimited STAR Category 39		
19 Security Classif. (of this report) Unclassified		20 Security Classif (of this page) Unclassified		21 No of pages	22. Price*

National Aeronautics and
Space Administration

Lewis Research Center
Cleveland, Ohio 44135

Official Business
Penalty for Private Use \$300

SECOND CLASS MAIL

ADDRESS CORRECTION REQUESTED



Postage and Fees Paid
National Aeronautics and
Space Administration
NASA-451

NASA
