

NASA TECHNICAL MEMORANDUM

NASA TM-77976

NASA-TM-77976 19860007868

AERODYNAMIC DESIGN TRENDS FOR COMMERCIAL AIRCRAFT

LIBRARY COPY

JAN 30 1986

LANGLEY RESEARCH CENTER

LIBRARY, NASA

HAMPDEN, VIRGINIA and H. Koerner

(A85-40302#)
ORIGINAL

Translation of "Aerodynamische Entwicklungsrichtungen fuer Verkehrsflugzeuge", Deutsche Gesellschaft fuer Luft- und Raumfahrt (German Aerospace Society), Annual Convention, October 1-3, 1984, Hamburg, West Germany, DGLR Paper 84-082, pages 1-53.

NATIONAL AERONAUTICS AND SPACE ADMINISTRATION
WASHINGTON D.C. 20546 JANUARY 1986

STANDARD TITLE PAGE

1. Report No. NASA TM-77976	2. Government Accession No.	3. Recipient's Catalog No.	
4. Title and Subtitle AERODYNAMIC DESIGN TRENDS FOR COMMERCIAL AIRCRAFT		5. Report Date January, 1986	
		6. Performing Organization Code	
7. Author(s) R. Hilbig and H. Koerner		8. Performing Organization Report No.	
		10. Work Unit No.	
9. Performing Organization Name and Address SCITRAN Box 5456 Santa Barbara, CA 93108		11. Contract or Grant No. NASW-4004	
		12. Type of Report and Period Covered Translation	
12. Sponsoring Agency Name and Address National Aeronautics and Space Administration Washington, D.C. 20546		13. Type of Report and Period Covered Translation	
		14. Sponsoring Agency Code	
15. Supplementary Notes Translation of "Aerodynamische Entwicklungsrichtungen fuer Verkehrsflugzeuge", Deutsche Gesellschaft fuer Luft- und Raumfahrt (German Aerospace Society), Annual Convention, October 1-3, 1984, Hamburg, West Germany, DGLR Paper 84-082, pages 1-53.			
16. Abstract Recent research on advanced-configuration commercial aircraft at DFVLR is surveyed, with a focus on aerodynamic approaches to improved performance. Topics examined include transonic wings with variable camber or shock/boundary-layer control, wings with reduced friction drag or laminarized flow, prop-fan propulsion, and unusual configurations or wing profiles. Drawings, diagrams, and graphs of predicted performance are provided, and the need for extensive development efforts using powerful computer facilities, high-speed and low-speed wind tunnels, and flight tests of models (mounted on specially designed carrier aircraft) is indicated.			
17. Key Words (Selected by Author(s))		18. Distribution Statement Unclassified and Unlimited	
19. Security Classif. (of this report) Unclassified	20. Security Classif. (of this page) Unclassified	21. No. of Pages 54	22. Price

AERODYNAMIC DESIGN TRENDS FOR COMMERCIAL AIRCRAFT

By: Dipl.-Ing. Reinhard HILBIG
MEB-UT, Bremen

Dr.-Ing. Horst KOERNER
DFVLR, Institute for Aerodynamic Design,
Braunschweig

1984 Annual Conference of the

DEUTSCHEN GESELLSCHAFT FUER LUFT- UND RAUMFAHRT E.V. (D.G.L.R.)

Hamburg, October 1 to 3, 1984

DGLR No. 84-082

Summary

We initially present the starting position, parameters and requirements for the introduction of new passenger plane technologies seen from the industrial aspect. Aerodynamic developments are outlined and their impact on new and further developments are described.

/1*

The following central points of development are investigated more closely:

- New transonic air foil technologies with "variable camber" for drag/lift ratio and buffeting control including "load" control
- Transonic air foil technology with " shock boundary layer control"
- Passive and active laminarization of transonic air foils
- Integration of new propulsion systems including propellor/fan systems
- aspects of over-all configurations.

Based on examples, ideas for potential research programs are presented for the development and application of the aforementioned technologies. It is assumed that an effective cooperation can be achieved between basic research of participating universities, application-orientated research of the DFVLR (German Institute for Air and Space Research) and industry.

* Numbers in margin indicate foreign pagination

1. Introduction

Aerodynamic research and development for civil aircraft is a necessity dictated by international competition.

2

The central point of German activities for civil aircraft construction consists of the cooperative effort for the AIRBUS planes. This is made up of MESSERSCHMITT-BOELKOW-BLOHM (MBB) and AEROSPATIALE (AS) as main partners of the AIRBUS-INDUSTRY(AI). The AI plays a "David-role" opposite the BOEING giant. Creativity and the introduction of new technologies are therefore the prime requirements for the AI's success. This was achieved in the past for the first AIRBUS plane A300 by introducing a two-engine design for wide body aircraft and for the AIRBUS' second family member, the A310, by using transonic air foil technology.

These successes, however, should not ignore the problems and risks associated with the development of large aircraft (development cost of up to two billion dollars). The various nations making up the AI bring with them a positive attitude based on a national desire for prestige in the field of competition and are interested in obtaining, e.g., the "most valuable" construction components. A far more difficult matter is the question of responsibility for research and development of new technologies, the early availability of which during the initial phase of such a new program (like the present TA11/TA9 AIRBUS), defines the technology standards which in turn determines the competitiveness of the product at a later stage.

The German aircraft industry, as the AI's main partner, can only carry out its share if the limited resources of basic application and industrial research are better utilized. This requires well coordinated national and international research programs.

The direction of research must, from the point of view of aerodynamics, be formulated by specialists in industry and research institutes. Aside from aerodynamics all faculties of modern aircraft design must also be involved.

2. Direction of aerodynamic developments

3

2.1 Transonic air foil technology with variable camber

It has been the conventional goal to achieve higher efficiencies by the introduction of new technologies. The aerodynamic engineer tried to achieve this, e.g., by improving the drag/lift ratio and lift limit of an air foil. There are, however, other important motives for research and development. Development costs of modern large-body planes have increased extremely during the last decades, whereas, on the other hand, market requirements create strong, short-term fluctuations. This could put into question whether there will be a sufficient number of planes in order to carry out an economically sound program. We have sought to overcome this problem in recent times by developing new variations of existing designs. However, if the number of modifications required are many then this may not present a cost efficient solution. It therefore seemed practical to look for new technologies which are flexible enough to follow the changing requirements of air lines. The technology presented in the following consists of an air foil with variable camber and offers a contribution to achieving the goal with the motto "higher efficiency with flexible applications".

A thorough investigation of the transonics of technology, e.g. in the advanced development of AIRBUS planes, showed us the great influence which wing camber has on efficiency characteristics and led us to the concept of air foils with variable camber (1), (2), (3), (4) and (5) and (Fig. 1). Existing uplift supports and control surfaces were used to create the necessary camber. Dividing the trailing edge into several segments allowed us to vary the camber along the wing span.

Fig. 2 shows a design principle for the leading edge. It is marked by the introduction of a partly flexible auxiliary flap at the under-side of the profile. Aside from influencing the air flow during cruising, the take-off position of the slat gap has been blocked. This solution can thereby also improve take-off efficiency. The less favorable slat profile, resulting

4

from a decreasing nose profile, can be considerably improved for up-lift, i.e., during landing. This design principle is, unfortunately, a rather costly one.

Fig. 3 shows the principle of camber variations by means of flexible wing segments at the wing's trailing edge. The camber variation is achieved by the combined action of spoiler/air brakes with a one-part trailing edge flap. If, apart from the pure flap rotation, an additional fowler action is permitted (this is a better design for some flap systems), then the application flexibility can still further be enhanced due to the surface enlargement.

As investigations have shown, the combined adjustment of leading and trailing edge represents an optimized solution. A "flexible skin" solution for wings of civil aircraft does not appear to be realizable in the foreseeable future. But even without the costly leading edge adjustment and using the trailing edge flaps only, this offers sufficient aerodynamic advantages and service flexibility to make it seem a feasible solution.

Based on an example we wish to demonstrate the aerodynamic effects on the efficiency of a modern air foil with variable trailing edge camber. The data has been collected during wind tunnel tests with models where the individual camber configurations were prefabricated. Contour interferences, caused by the interaction of spoiler and flap, were taken into account. The sensitivity of wing air flow towards such interferences depends on the initial pressure distribution.

Fig. 4 shows the effects on the polar points. As expected, the "zero" lift increases with increasing camber. However, the occurrence of stronger non-linearities takes place at about similar attack angles, i.e. up-lift limits are expanded considerably. An important indicator for the design load is that the larger camber (Δ -symbol) is only attempted at the upper lift range, i.e. at greater cruising heights. At that up-lift range the resistance gains are significant.

When transferring wind tunnel results to life-size models and incorporating such a concept of variable camber in the trailing edge area, changes in the L/D characteristics are produced as shown in Fig. 5.

The larger service flexibility over the cruising mach number can also be seen in Fig. 6.

These results are confirmed when comparing the lift limits (buffet onset and drag rise) in Figures 7 and 8.

Aside from influencing the efficiency characteristics, a camber control in the direction of the wing span can also influence the load distribution during manoeuvres. Fig. 9 shows an example at the upper lift range whereby the root bending moment can be reduced by 12.8% while maintaining the same lift. The inner wing is more curved than the outer wing offering a better aerodynamic utilization.

The main problem zone for the realization and optimization of such air foil technology (Fig. 10) still lies with the attached profile flow, i.e., the interferences between shock and boundary layers with considerable effects on the trailing edge flow, especially when at the onset of separation. Under 3D-conditions at the air foil, the problem zone of "flow around the nose" developing a boundary layer, has to be added including the question of laminarization. The problems at the shock and trailing edge area become still more complex due to 3D effects (e.g. "twisted" boundary layer profiles near the trailing edge).

Such flow conditions are of fundamental importance for the efficiency and performance of modern air foils. Basic research, experimental and numerical, to describe such conditions accurately, are planned by MBB within the ZKP research program "air foils with controlled flow". Such work is also a focal point of the DFVLR. Universities, amongst them the Institute for Aerodynamic and Aerodynamic Machines (6) at Karlsruhe and Berlin, have also carried out such work which it is hoped will be continued.

2.2 Transonic Air Foil Technology with Shock-Boundary Layer Control

When designing shock-free air foils for passenger planes, shock formation is unavoidable with increasing lift and Mach numbers. This leads to the well-known operational limitation of modern civil aircraft. A study was initiated by VFW (7) in 1978 in cooperation with the DFVLR to determine these adverse interactions of the shock-boundary layer. Results of this study have been reported regularly (8), (9). The investigation has, so far, been limited to a 2D flow shown in Fig. 11. The shock-boundary layer area of a high efficiency transonic profile was influenced by suction (active boundary layer-BL-control) and by using the pressure differential in front and behind the shock, thereby creating a ventilation flow (passive BL control).

The effects on the profile flow under off-design conditions are shown in Fig. 12: the shock-induced separation is delayed and leads to much higher lift limits. This result which was achieved with a passive BL control by ventilation through the double-slot design, has also been obtained for the "perforation" design. The effects on the BL formation between shock and trailing edge are quite significant and may have similar effects on the resistance.

The D/L numbers measured in the wind tunnel with and without BL control as well as the gains in lift are shown in Fig. 13 and 14. 7

A numerical transference of these results onto an air foil with shock-BL control has shown a high potential provided a mostly isobar pressure distribution can be achieved together with a stable shock position under off-design conditions. Such design goals are indeed possible with the above-described variable camber technology.

A realization of such goals requires the availability of high-power computers and test plants in which aerodynamic laws can be simulated with fair accuracy (vector calculators, wind tunnels for high and low velocity ranges). DNW and ETW are valuable aids for the development of modern, large-body planes.

2.3 Reduction of the Friction Resistance/Lamination

A significant portion of a plane's total resistance (about 50%) is caused by the friction resistance. There are two ways of reducing this resistance (10) namely

- by laminarization of the boundary layer (BL)
- and/or by special measures to reduce turbulent shear stresses.

Both ways are dealt with in this chapter with special attention to the laminarization process, since the degree of improvement which can be achieved is quite extraordinary (11).

Fig. 15 shows the resistance reduction obtained by laminarization of a plate laminated on one side. Since the laminar BL at equal pressure is already affected by a Reynolds' number of under 10×10^6 measures must be taken to obtain an artificial BL stabilization. Three methods offer a certain technical interest, namely laminarization through

- shaping
- suction
- cooling

These three methods will be discussed in the following:

2.3.1 Laminarization through shaping

The shaping method has found wide acceptance in air glider construction and is also now being used for sports and business planes (12), (13), (14). The principle is also used for blade arrangement in turbo-machinery. This method utilizes the fact that transition is laminar/turbulent, i.e., the critical Reynolds'

number at which transition occurs can be greatly influenced by the pressure gradient within the flow. (Fig. 16 shows the critical Reynolds' number for the indifference point in relation to the pressure gradient). This fact is utilized at Air glider and blade grids by arranging the pressure distribution at the upper and lower side in such a way so as to obtain as long a contact length as possible. Fig. 17 shows such a design for a camber flap with a minimum resistance of 0.0037.

The actual gains at such low Reynolds numbers can also be achieved at the upper end as long as the pressure distribution follows the stability requirements. Fig. 18 shows pressure distributions as they could look for laminar profiles at higher Re-numbers (16). However, their development will require rather large expenditures.

What is the situation for basic design data for airfoils laminarized by shaping? The design and check calculations of transonic, laminar profiles can be based on existing procedures which, however, require significant improvements (shock-BL problems, trailing edge flow, flow around the nose). There are unanswered questions with regard to predictions of the laminar/turbulent transition. Present theories allow only the calculation of instability points and modes of amplitudes of induced BL vibrations. The correlation towards the transition point must be made experimentally. A further difficulty is that the experimental tool of the aerodynamics engineer, the wind tunnel, must be used with caution, since all wind tunnels show turbulences which are not present in the open atmosphere. Fig. 19 (17) shows the critical Re-number in relation to the degree of turbulence. This means that a correlation factor has to be found for actual flight testing.

During the past years the DFVLR has carried out transition studies, the results of which can be summarized as follows:

- Test evaluations have shown that laminar flow on part of the foil is possible at high Re-numbers (40×10^6). It has been

further established that flow up to a moderate sweep angle ($\varphi = 20 - 30^\circ$) can be kept laminar. However, with increasing Re-numbers and sweep, the lines look like a pair of scissors closing.

- Wing stability calculations can be made for longitudinal and perpendicular flow stability. The amplitude behavior of induced BL vibrations affords a correlation determination of the transition point.
- During the numeric simulation of non-linear 3D instability, horse shoe turbulences are produced during the end phase which characterize a turbulent BL. Linear as well as non-linear stability calculations require the use of a vector computer (e.g., CRAY 1 S).

Summarizing, one can say that the central problem in the development of laminar profiles for higher Re-numbers lies in the accurate predictability of the transition. This will require experimental testing in flight and wind tunnels with low turbulence as well as stability calculations and determination of correlations for establishing transition criteria. A research program has been initiated which is carried out in cooperation between institutes and industry. When the result of this study becomes available it will be necessary to undertake an in-flight test of a laminar profile at higher Re-numbers. A proposal for this is shown in Fig. 20. Pressure distribution and polar points for a laminary foil, designed for the model foil of the VFW-614, have been shown in Fig. 21 (14)

2.3.2 Laminarization by Suction and Cooling

Laminarization by suction has also come to the foreground next to the shaping procedure. In this case, the laminar BL is kept laminar either by slot exhaustion or suction via a porous surface. This type of laminarization affords an application up to high

Re-numbers (100×10^6) and also functions in areas of increasing pressure, i.e., towards the trailing edge. Furthermore, this method can be used for the body and all laminarized parts so that spectacular L/D number gains have been prognosticated. Pfenninger has designed extreme configurations which, as theoretically predicted, have L/D numbers of over 100 representing a six-fold improvement compared to the best of the present subsonic transport planes. The very impressive potential of this method must not hide the fact, however, that there are difficulties and unresolved factors which can only be clarified with considerable expenditure. One of those unresolved problems is the clogging of the porous surface and the stability of the BL during small and minute levels of contamination, e.g. ice crystals at very high Re-numbers. However, the suction technology is of special importance for hybrid solutions, i.e., laminarization through shaping assisted by suction at especially critical areas. The DFVLR is at present preparing tests on a suction profile with Re-numbers of up to 10×10^6 . Fig. 22 shows the model structure which will be tested in transonic tunnels of the DFVLR-Goettingen in 1985 (18). 11

As with suction, cooling the surface also produces a stabilization of the BL. A technical realization would be possible if fuel, e.g. liquid hydrogen, were to be used. Since such a technology is not feasible at present it should be set aside for the time being.

Large sums of money spent by United States universities and industry confirm the importance which that country attaches to the laminarization of flying machines. NASA, for example, has initiated an extensive research program in cooperation with all major aircraft companies. These studies, aside from wind tunnel testing, involve large-scale in-flight tests (19).

In Germany too, activities in this field have increased. They are especially furthered by the DFVLR program ALVAST (aerodynamic efficiency increase for subsonic transport planes).

2.3.3 Reduction of the Turbulent Friction Resistance

Parallel to laminarization there have been frequent investigations during the past years of reducing wall shear stresses at turbulent BLs. This seems highly interesting at very high Re-numbers, e.g., at the fuselage.

At BLs of larger contact lengths the shear stress at the wall can be reduced by tangential exhaustion. Such a method can be technically realized far more easily than laminarization. However, obtained resistance reductions are much lower than with laminarization.

Another very intensively studied method is the influence on the turbulence structure by different surface shapes (10). One method consists of providing the surface with longitudinal grooves (Fig. 23) whereby the riblets must be sufficiently high so that they will penetrate the laminar sub-layer. Another possibility is the provision of so-called LEBUs (Large Eddy Break Unit) which also affect the turbulence structure. Both cases aim at breaking up large turbulence structures, thereby reducing the friction resistance.

12

Both methods have produced friction resistance reductions in the laboratory which are, however, well below the ones of laminarization. In addition, the question comes up as to how to create and operate the necessary surfaces and devices of a life model. It seems likely that after installation the net gain may be marginal.

2.4 Integration of New Propulsion Systems - Prop-Fan

Like laminarization the integration of new propulsion systems will require development expenditure, on the one hand, to create a "validated technology" and which, on the other, will bring significant fuel savings. We will deal here with two subjects, namely, the integration of high by-pass engines into the airframe and the prop-fan.

High by-pass engines are successfully used for subsonic civil aircraft. The close position of the engines at the wings creates interference problems, especially additional resistances, for which design solutions have to be found by extensive model testing. Aside from the effects of the engine pods and pylon as bodies of resistance, the engine exhaust itself is the major cause of resistance. The cold and hot jets produce turbulent propagation and mixing problems in a mobile external field of flow at very high subsonic speeds. Theoretical and experimental investigations of these problems have become one of the major research tasks.

In this connection the use of "turbo-powered simulators (TPS)" 13
in wind tunnels has gained in importance in order to

- guarantee a highly realistic simulation of engine jet exhaust
- optimize the pod geometry with respect to shape and installation at frame or wing.

There has been little systematic investigation into these problems. This may be due to the fact that such studies are rather costly.

While the improved integration of by-pass engines continues to produce better designs, the integration of a prop-fan represents a special challenge on research and development. It has been predicted that such future engines, depending on their complexity, can have up to 30% of fuel savings (20).

The United States is carrying out an extensive development program for such engines which includes design studies, wind tunnel testing and in-flight testing (21). The importance is underlined by the fact that Congress has doubled NASA's allowance for this program.

The European activities so far have been concentrated on improving conventional propellers whereby DORNIER/HOFFMANN/DFVLR have made a significant advance by developing the TNT

propellor (22). European studies on the actual prop-fan are being carried out solely by ONERA (23) if one ignores some preliminary investigations by Germany and England. A larger program has been proposed within the framework of GARTEUR.

Fig. 24 shows a prop-fan and its characteristic data in comparison to a conventional propellor. The prop-fan distinguishes itself from a conventional propellor by

- a smaller diameter
- a larger number of blades and blade depth
- sickle-shaped blades
- high blade tip mach number ($Ma_{TIP} \approx 1.1$).

14

In order to obtain the required thrust for subsonic transport planes the circular area load will have to be considerably higher than for a conventional propellor. As a consequence, there are a large number of blades and greater blade depths. The high circular area loads result in increased losses due to increased swirl and decrease of static pressure at the core of the jet stream. These losses can be avoided if a co-axial prop-fan is used (Fig. 25). While the single prop-fan can bring a fuel saving of about 20%, a co-axial prop-fan can achieve a further saving of 8%. An intermediate solution is the accommodation of a stator behind the prop-fan which eliminates twirl and co-generates pressure (24). From the efficiency standpoint such an arrangement may be placed between the single and co-axial prop-fan.

The problem zones for this mode of propulsion are summarized in Fig. 26. The main points are as follows:

Based on the assumption that civil transportation planes will use, as before, American or "international" engines, and that the USA will supply prop-fan engines, there still remains the central problem of prop-fan integration within the air frame. Two types of installation seem feasible: at the wings or at the rear of the fuselage, arranging the engine for either thrust or pull.

All integration variations have advantages and drawbacks which still have to be worked out using models with prop-fan simulation in wind tunnels.

Theoretical design work is also necessary which requires relatively large expenditures since a practical prop-fan simulation can only be done by using the Euler equations. This in turn requires the use of a vector calculator.

The second main task will be the determination and reduction of noise of the prop-fan. Due to the high blade tip mach numbers ($Ma \approx 1.1$) the prop-fan produces a very high noise level in the immediate vicinity. This level must be reduced by measures at the prop-fan and by noise protection of the cabin walls. Due to the quadruple character of the noise its level diminishes very quickly with distance so that there should not be any problems during take-off, landing and over-flight. Since the noise source is not compact in itself, it creates its own attenuation effect. The focal problem will be noise in the immediate vicinity and in the cabin. This will require model tests in DNW and testing in smaller, acoustically-lined wind tunnels. With respect to theory and design we expect to make progress if suitable aerodynamic procedures are available (see above). These studies should be carried out on single prop-fans as well as on co-axial prop-fans.

15

The DNW is well suited to testing at the low-speed range while for high velocity studies there is at present no German tunnel available so that a European cooperation would be desirable. In-flight testing and the high cost associated with it should be postponed to the development stage.

3. Air Foil Design and Total Configuration Aspects

The aerodynamic efficiency of air foils is largely determined by its lay-out and the shape of the wing tip. In this field, too, improvements are possible especially when using new materials such as GFK and CFK.

An important parameter for the wing design is the wing sweep angle which, for the AIRBUS, lies at 28° ($\frac{1}{4}$ line). De-sweeping the wing (Fig. 27)

- produces a better uplift performance (c_{Amax} , Tip-Stall) and
- allows larger side aspects at identical spar lengths.

16

Since, however, the resistance increase occurs earlier at identical profiles (decrease of sweep effect), the planes must reduce their travelling speed from $Ma = 0.78$, depending on the sweep, to 0.75 ($\psi = \sim 20^\circ$) of 0.73 ($\psi = 0^\circ$). This is not very compatible with economic requirements since the aerodynamic quality is proportional to the Ma-number. It is, therefore, essential to investigate if transonic profiling would allow an almost unswept wing for a cruising speed of $0.76 \div 0.77$. De-sweeping has also a favorable effect on wing laminarization. The DFVLR is presently carrying out a study on unswept wings.

Another very interesting aspect is a forward sweep. A solution to the static divergence problem seems possible by the use of non-isentropic CFK structures which requires in turn a reformulation of the aerodynamic problem.

Tests carried out so far have shown that the wing root design poses extreme difficulties. Even if a design for an acceptable pressure distribution can be found, the off-design has shown great difficulties in the wing root (profile nose, wing buckling) due to the double singularity. This causes strong shock formation and flow separation at the wing root area. All this could nullify the advantages of a forward swept wing:

- lower root bending moment
- better efficiency of the aileron
- favorable canard coupling
- higher suction power at the leading edge.

These problems could partly be overcome by a forward tail (canard) and/or by enlarging the wing at the root (Fig. 27) which gives relief to the inboard wing.

One conventional method for reducing resistance is the increase of the side aspect ratio which is directly related to lift-dependent resistance. Conventional transport planes have a side aspect ratio of 7 to 8, the AIRBUS' one being 9. For aerodynamic reasons a further increase is desirable which, however, is opposed by structural and fluttering problems. Then again, studies have shown that by incorporating canard designs and new structures, side aspect ratios of 14, are possible.

Another possibility of reducing the lift-dependent resistance is the installation of winglets. Both wing span enlargement and winglets have recently been offered as optimized solutions, although one cannot be certain that this is in fact so. One can say generally that winglets can be an optimized solution under certain circumstances (limited turbulence bending moment, wing span cannot be increased) when an existing plane has to be re-equipped. However, when undertaking a completely new design and creating a new lay-out, the planary solution at the tip area may be the most advantageous one.

All presently operating transport planes have rearward tails. This arrangement offers stable flight conditions but suffer from the disadvantage that during fully trimmed flight, the tail induces a downward lift or at best a small up-lift when approaching the stability limit. If the main wing is subject to top-heavy loads, as is the case during high "rear loading", then the down-lift is still more magnified.

If the tail assembly is placed in front of the main wing (canard arrangement), it will then produce up-lift and so relieve the main wing. Fig. 28 shows a sample configuration for cruising speeds and for high up-lift conditions where such relief is quite considerable (around 30% of the shown configuration). Of course, the canard assembly is now under higher stress and which now has to be provided with up-lift supports. As a consequence:

- the main wing can be designed for a smaller c_A during cruising

- the high up-lift system becomes less complicated; a very interesting aspect when designing laminar foils.

Looking at the stability requirement, namely that the center of gravity must be in front of the neutral point, then the canard solution would require a total center of gravity in front of the wing by perhaps accommodating the engines at the canard. Fig. 29 (25) shows how such a configuration could look incorporating such an unconventional tail assembly.

In fairness, the disadvantages of the canard arrangement must also be pointed out and which are as follows:

- The main wing is subjected to an unfavorable, lift-up distribution, i.e., a little stressed inboard wing and highly stressed outer wing. The reason for this is that the inboard wing is in line with canard assembly. However, this problem can be overcome with wings of controlled flow (refer to Chapter 2.1)
- The high roll moment during push-thrust flight.

All these remarks apply to a naturally stable-flying aircraft. If the requirement for a natural, longitudinal stability is dropped then the scales turn in favor of the conventional design. However, in order to obtain the same up-lift efficiency from a conventional tail assembly as for the main wing of the configuration discussed here, one has to apply a negative stability of 50% of the reference wing discussion which is completely unrealistic for controllability reasons. It seems, therefore, reasonable to investigate the canard configuration further.

Concluding Evaluation

19

It can be stated that aerodynamic measures will bring significant improvements for the economic operation of subsonic transport

planes. There is a great attraction in the fact that by merely changing the shape, i.e., without additional cost, such improvements are possible. A pre-condition is, of course, to clarify the flow phenomena and the development of suitable design and optimization criteria. Another sound argument for aerodynamic improvements is the fact that most measures have a direct effect on the thrust-resistance equilibrium and thus have an immediate influence on the efficiency of the device.

Of the potentials discussed, three deserve special attention:

- air foils with controlled flow
- laminar foils
- prop-fan.

The results from the program "air foils with controlled flow" will be of great importance for TA9 and TA11. "Laminar wings" and "prop-fan" are planned for smaller aircraft of 80 to 150 seats in the 1990s. The "laminar wing" might find an intermediate application in the design of business planes.

Successful research and development in these fields will only be possible by concentrating on selected subjects and by cooperation between industry, DFVLR and universities as has been successfully practiced in other areas such as the working group STAB (flow and separation). Such work, however, will only be possible if all the necessary tools are available and usable, such as:

- high performance computers (CRAY 1S and successors)
- suitable low velocity wind tunnels (DNW, KKK) and high velocity tunnels (Cryo-tubular wind tunnel, ETW)
- planes in-flight testing (availability of an aircraft for laminarization tests).

20

With such concentration of men and money it should be possible, within a national framework, to make significant progress for the realization of the discussed technologies. However, consideration should also be given, if not one of more focal points should be tackled on an international basis like the GARTEUR project, a cooperation between France, Great Britain, the Netherlands and Germany. Efforts are under way to conclude a cooperative program for the "prop-fan" subject within the framework of GARTEUR.

Literature

- (1) Krenz, G.
Hilbig, R. Aerodynamic Concepts for Fuel-Efficient Transport Aircraft.
ICAS-82-1.5.2, (1982), pp. 800-810.
- (2) Mantel, Jr. Efficiency-increasing modifications on Transonic Air Foils of transport planes.
- (3) Hilbig, R.
Wagner, H. Variable Wing Camber for Civil Transport Aircraft.
ICAS-84-5.2.1, (1983), pp. 243-248.
- (4) Fischer, F.
Hansen, H. Leading edge and trailing edge modifications made on a transonic air foil.
ZKP-NEW II, Report No. 15 (1984).
- (5) Redeker, G.
Wichmann, G.
Oelker, H.-Chr. Aerodynamic Investigations on an Adaptive Airfoil for a Transonic Transport Aircraft.
ICAS-84-1.8.3, (1984), pp. 868-880.
- (6) Bohning, R.
Zierep, J. Normal Shock-Turbulent Boundary Layer Interaction at a Curved Wall.
AGARD-CP-291, (1980), pp. 17-1 to 17-8.
- (7) Thiede, P.
Dargel, G. Expansion of the Application Range of Transonic Profiles by Local Exhaustion of Boundary Layer.
BMVg-FBWT RUFo IV T/RF41/70021/71420, VFW, (1980).

- (8) Thiede, P.
Krogmann, P.
Stanewsky, E. Active and Passive Shock/Boundary Layer Interaction Control on Supercritical Airfoils.
AGARD-CP-365, (1984).
- (9) Krogmann, P.
Stanewsky, E.
Thiede, P. Transonic Shock-Boundary Layer Interaction Control.
ICAS-84-2.3.2, (1984), pp. 297-307.
- (10) - Improvements of Aerodynamic Performance Through Boundary Layer Control and High Lift Systems.
AGARD-CP-365, (1984).
- (11) Pfenninger, W. Laminar Flow Control, Laminarization.
AGARD-R-654, (1977), pp. 3-1 to 3-75.
- (12) Wortmann, F.X. Progress in the Design of Low Drag Aerofoils.
In Lachmann's book: Boundary Layer and Flow Control, Vol. 2, (1961), pp. 748-770, Pergamon Press, New York/Paris.
- (13) Eppler, R. Results of Combined Application of Boundary Layer and Profile Theory.
Journal Flugwiss. 8, (1960), P. 247-260.
- (14) Koerner, H.
Redeker, G. Recent Airfoil Developments at DFVLR.
ICAS-82-5.6.2, (1982), pp. 1099-1114.
- (15) Schlichting, H. Boundary Layer Theory.
G. Braun, Karlsruhe, 8th Edition: 1982.
- (16) Quast, A. Laminar Profiles for Transport Planes.
DFVLR-Mitt. 80-07 (1980).
- (17) Maddelon, D.V.
ed. Laminar Flow Control.
NASA CP-2218, (1981).
- (18) Thiede, P.
Dargel, G.
Krogmann, P.
Stanewsky, E. Studies of viscous drag reduction on supercritical wings by laminar flow control.
Proc. 6th US/FRG DEA-meeting, April 28.-30., Goettingen, 1981.

- (19) Wagner, R.D.
Fischer, M.C. Fresh attack on laminar flow.
Aerospace America, March 1984, pp. 72-76.
- (20) Godston, J.
Reynolds, C. Propulsion system installation configurations for future prop-fan powered aircraft.
AIAA Paper 83-1157 (1983).
- (21) Arndt, W.E. Propfans go to full scale.
Aerospace America, January 1984,
pp. 100-103.
- (22) Zimmer, H.
Hoffmann, R.
Horstmann, K.H. Investigations of Modern General Aviation Propellers.
AGARD-FDP-Meeting in Toronto, Canada,
(1984).
- (23) Bousquet, J.M. Propellers for High Speed Flight Efficiency.
L'Aeronautique et L'Astronautique
No. 88-1981-3, pp. 37-57, (1981).
- (24) Gearhart, W.S. Proposed arrangement to improve turbo-prop efficiency.
J. Aircraft 21, (1984), pp. 341-344.
- (25) Nangia, R.K.
ed. Proceedings International Conference Forward Swept Wing Aircraft.
University of Bristol, 1982.
- (26) Redeker, G. Aircraft with Canard Assembly.
German Patent Office P 3346 654.8, (1983).

THIS PAGE INTENTIONALLY LEFT BLANK

larger aspect ratio
reduced sweep
greater thickness
smaller surface

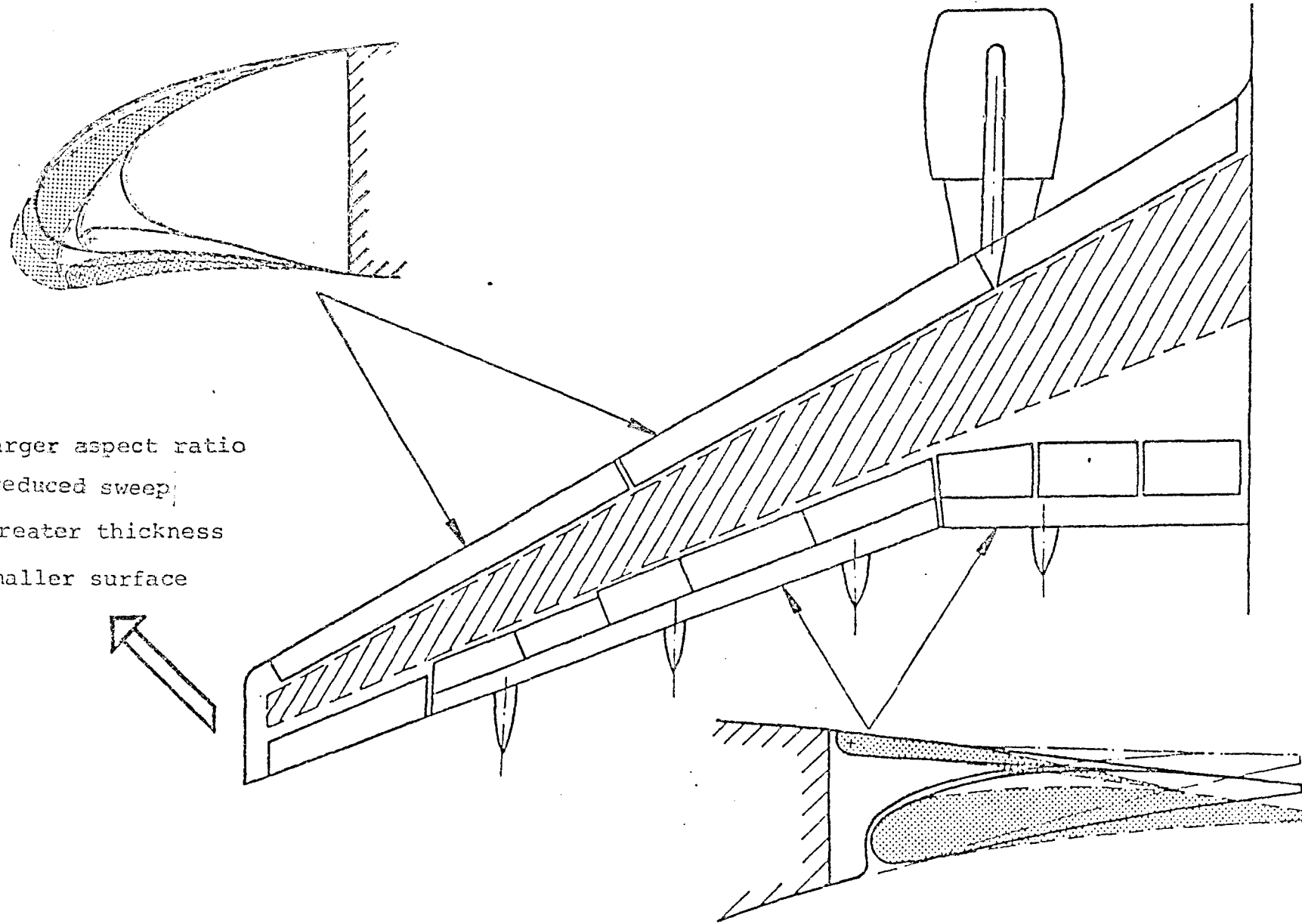

FIG.1 : DESIGN SUGGESTION FOR VARIABLE CAMBER

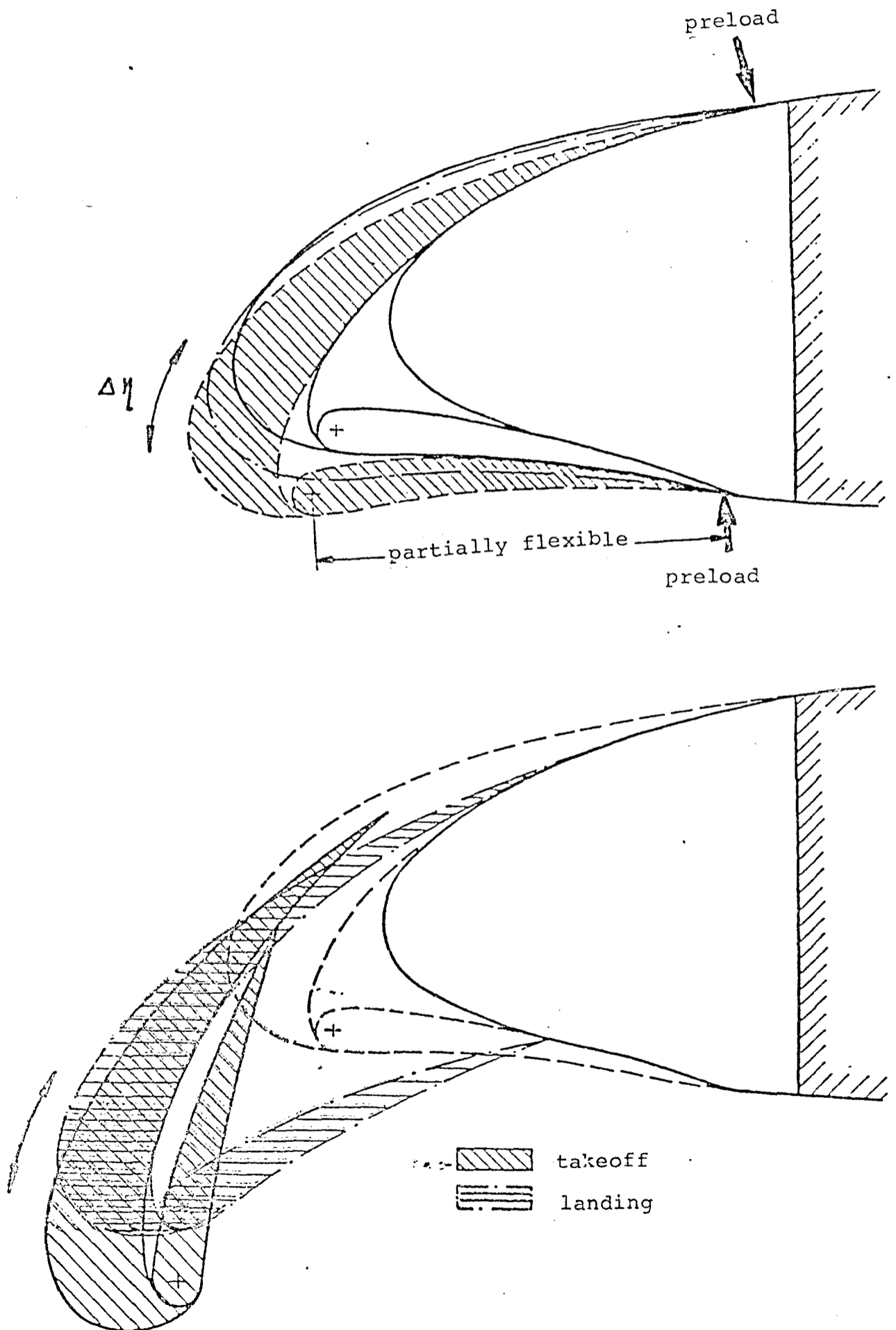
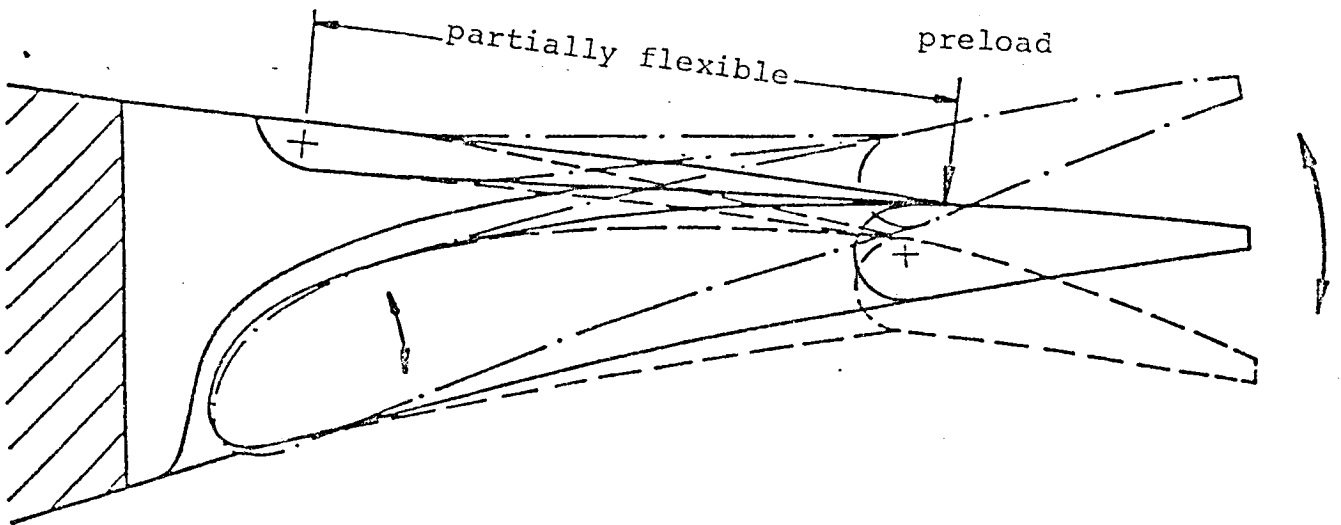
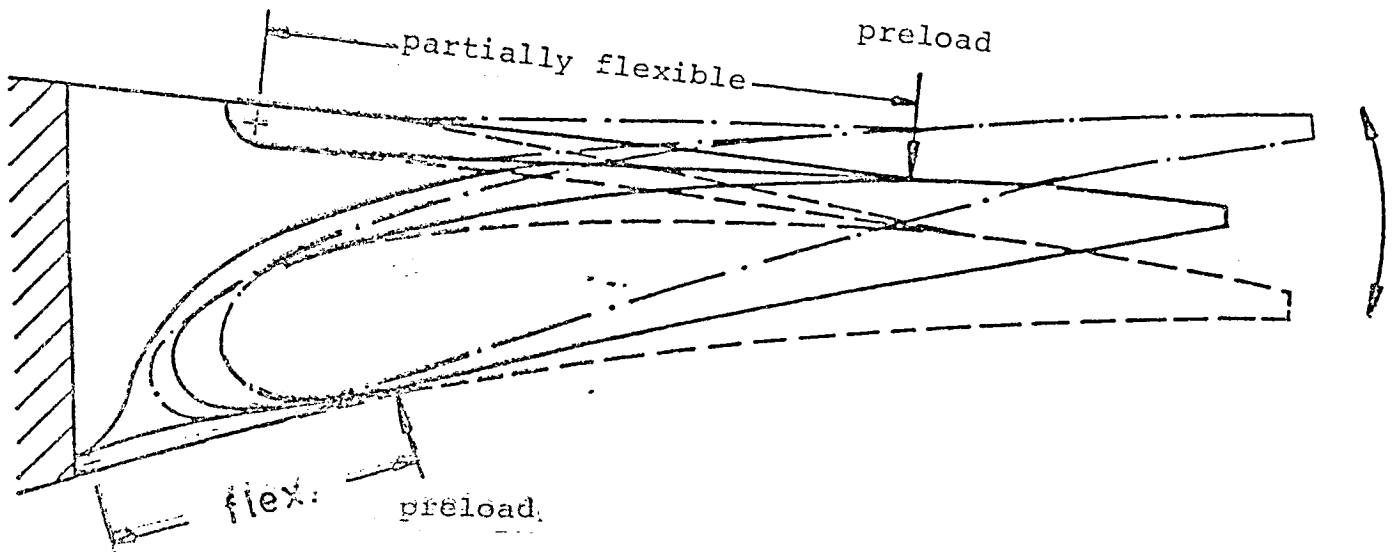

Fig.2 : BASIC DESIGN NEAR THE WING NOSE



variable camber without fowler



variable camber with fowler

Fig.3 : BASIC DESIGN AT THE TRAILING EDGE

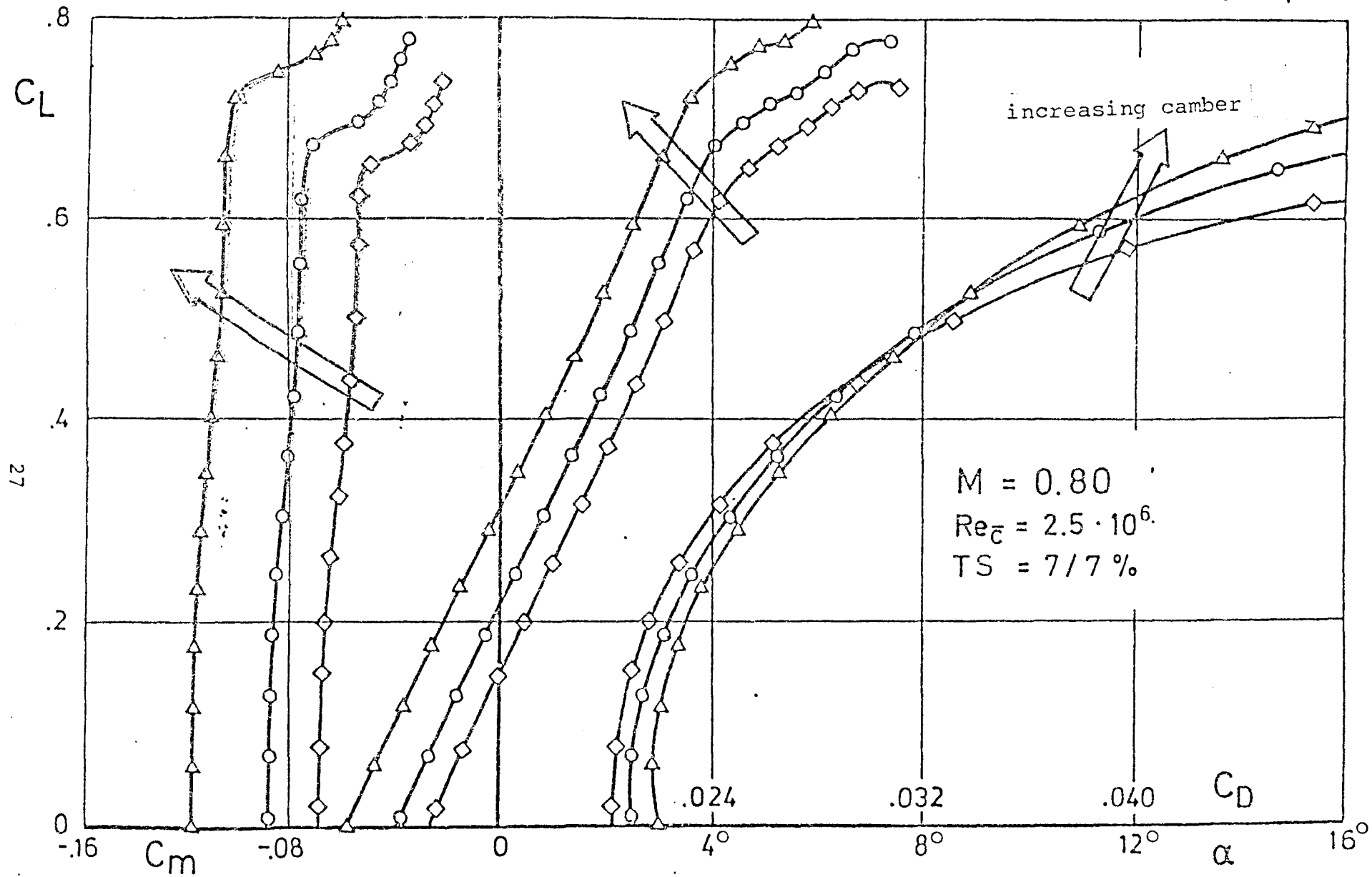

Fig.4 : CAMBER EFFECTS ON POLAR POINTS

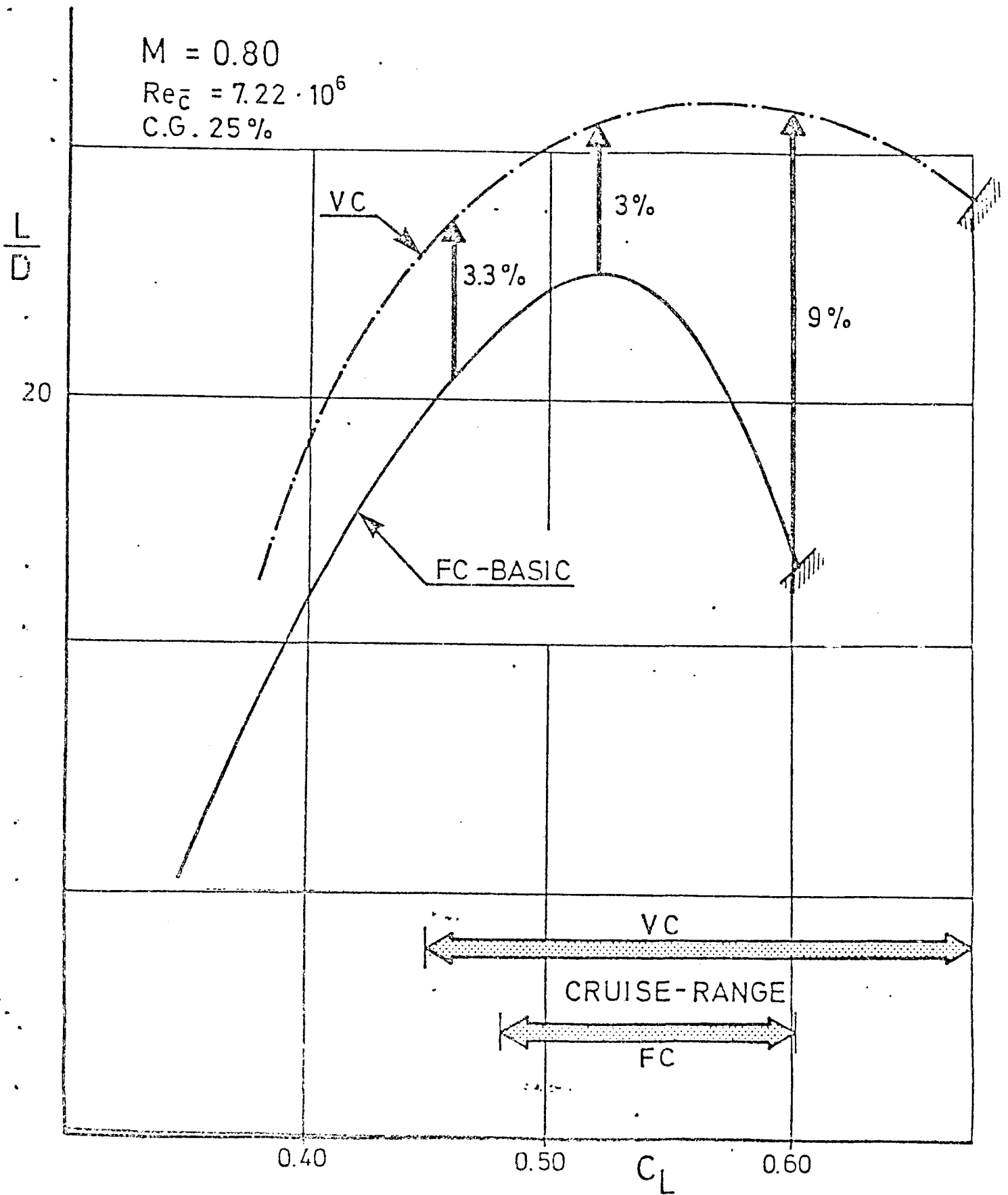

Fig.5 : INFLUENCE OF THE VARIABLE CAMBER ON THE
 LIFT DRAG RATIO

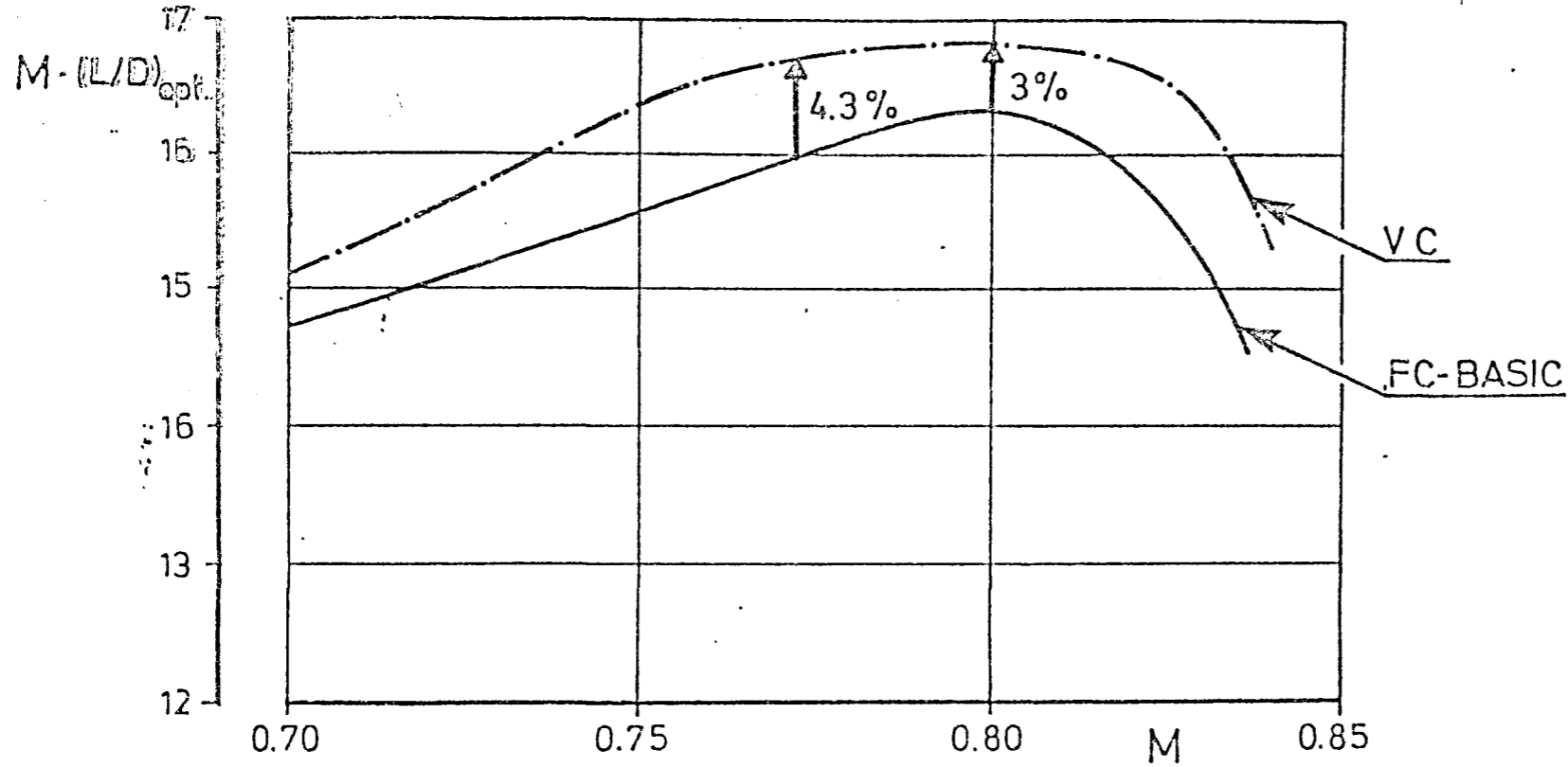

Fig. 6 : INCREASE OF AERODYNAMIC EFFICIENCY THROUGH VARIABLE CAMBER

0.2g PEAK TO PEAK
C.G. 25%

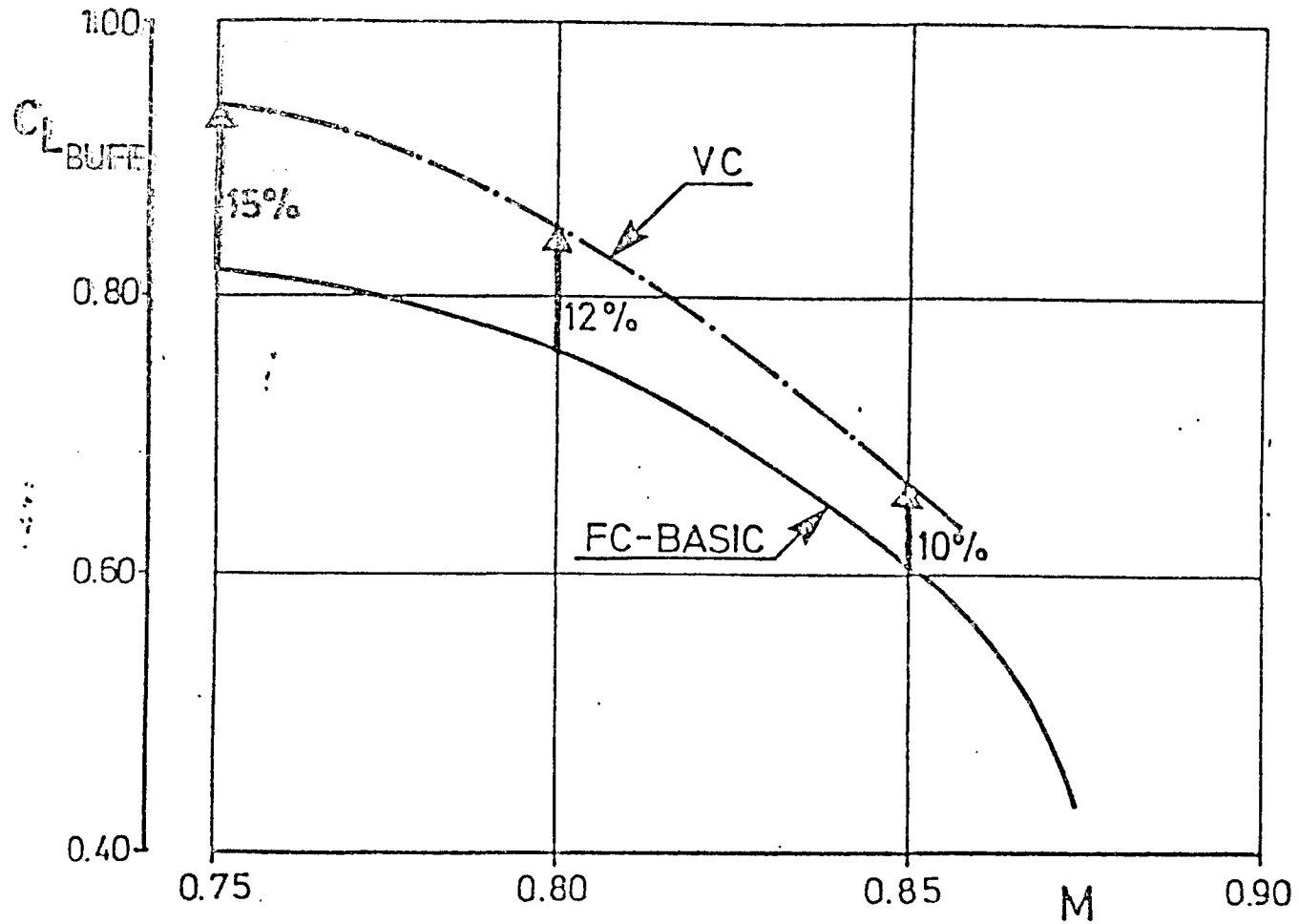

Fig.7 : VARIABLE CAMBER--
INCREASE OF THE BUFFET LIMITS

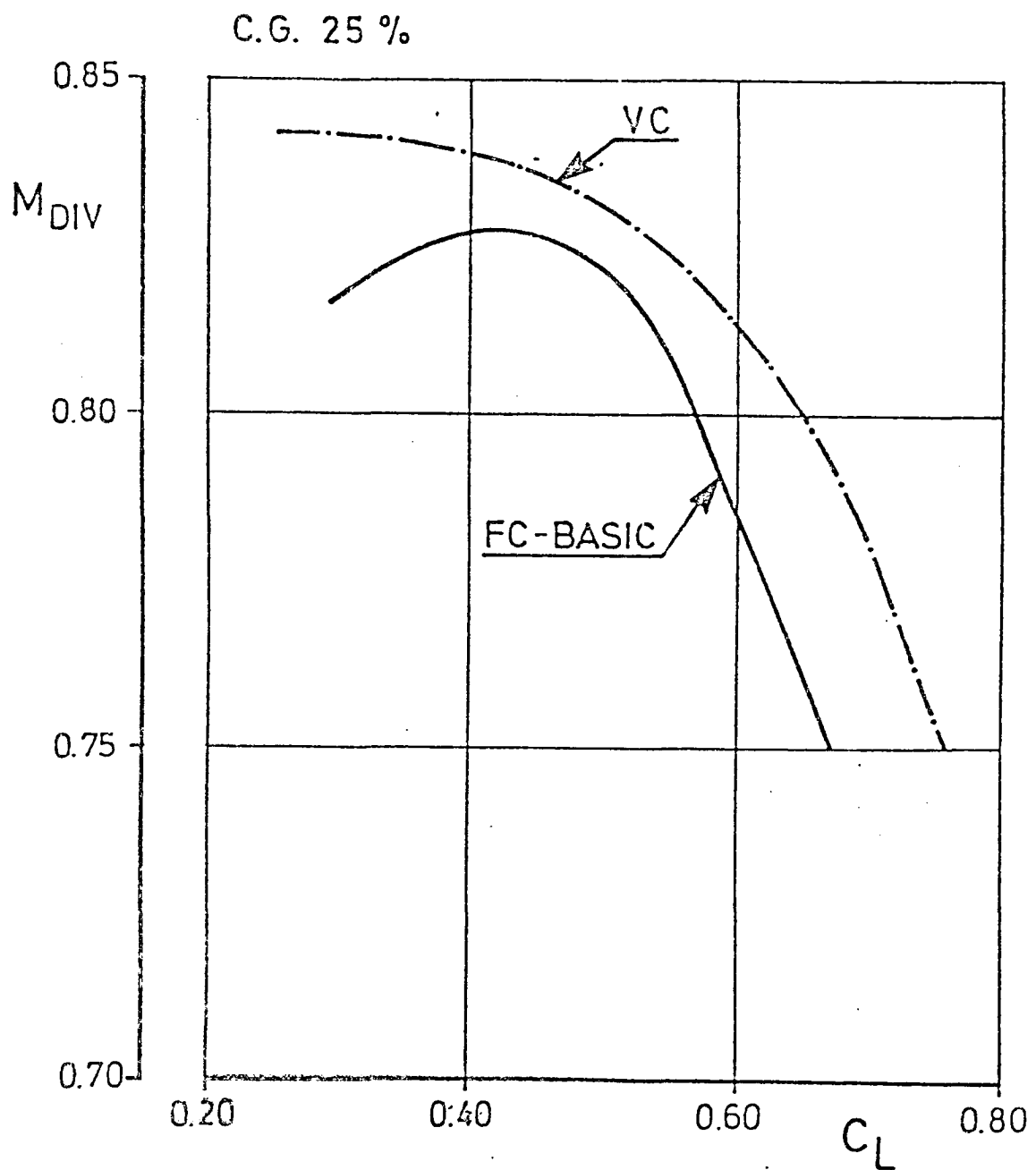

Fig. 8 : VARIABLE CAMBER--
INCREASE OF RESISTANCE-DIVERGENCE MACH NUMBER

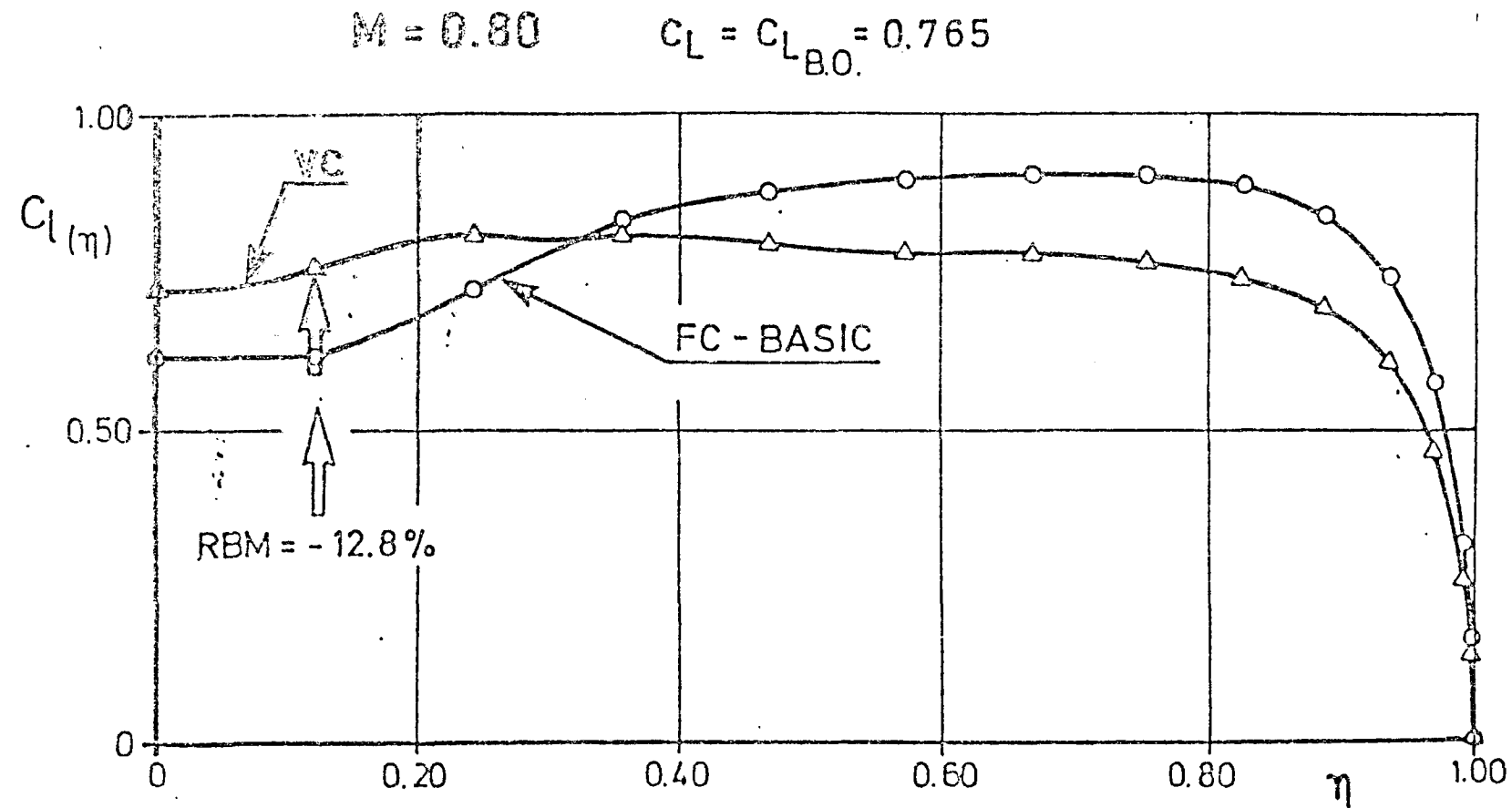

Fig.9 :

VARIABLE CAMBER--

MANOEUVRE--LOAD--CONTROL

MBB

TE 21

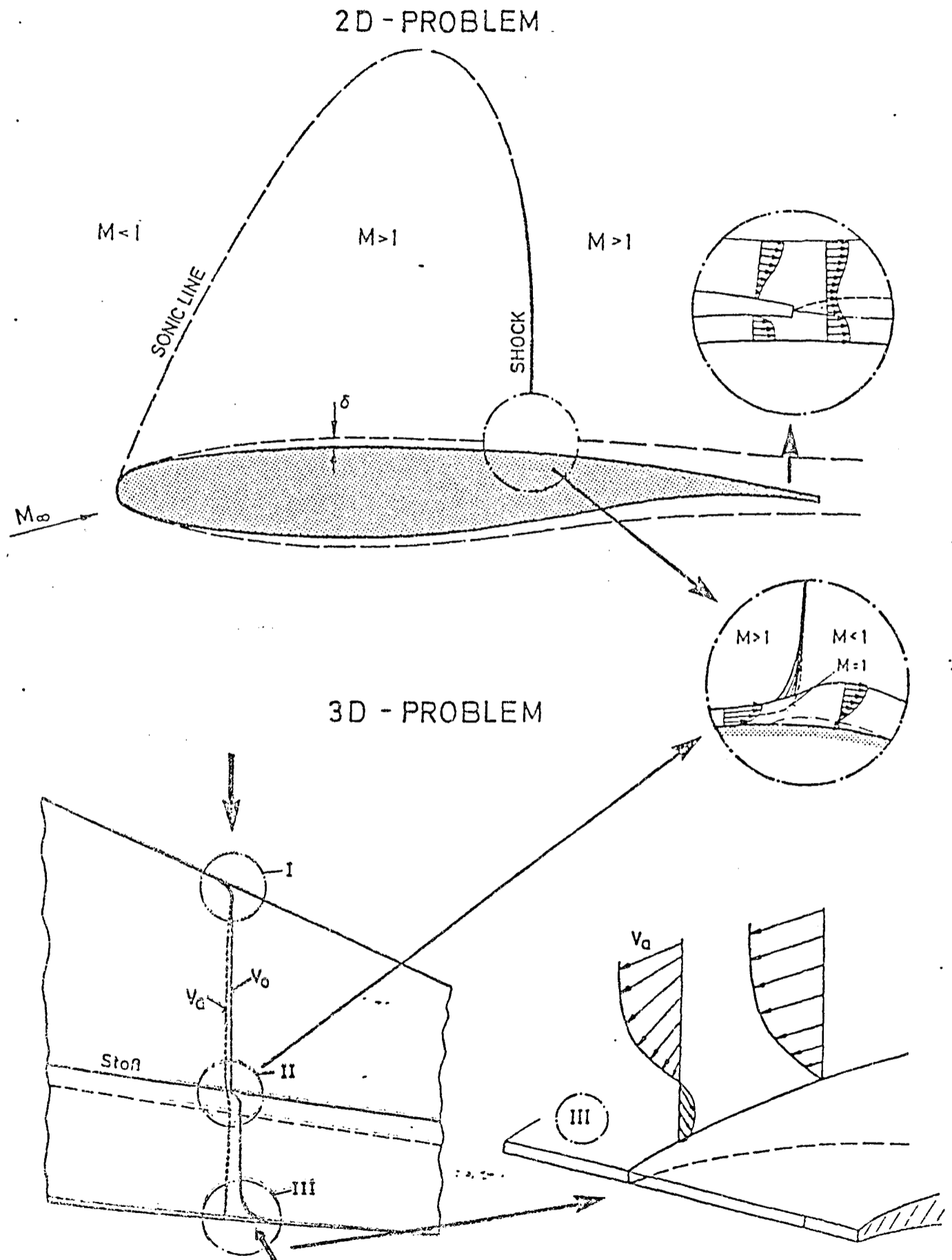
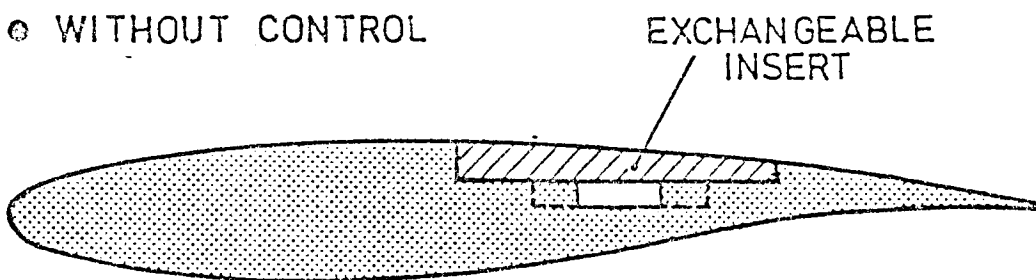

Fig. 10 : PROBLEM ZONES OF TRANSONIC FLOW OF PROFILE/AIR FOIL

AIRFOIL VFW VA-2

⊙ WITHOUT CONTROL



⊙ WITH SINGLE SLOT

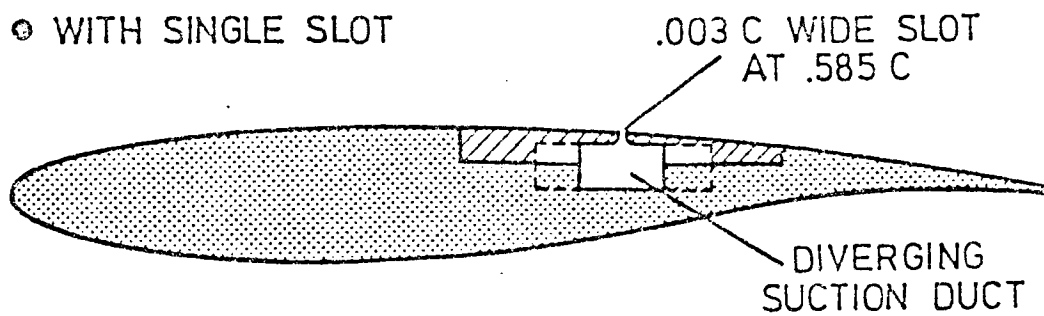

⊙ WITH DOUBLE SLOT

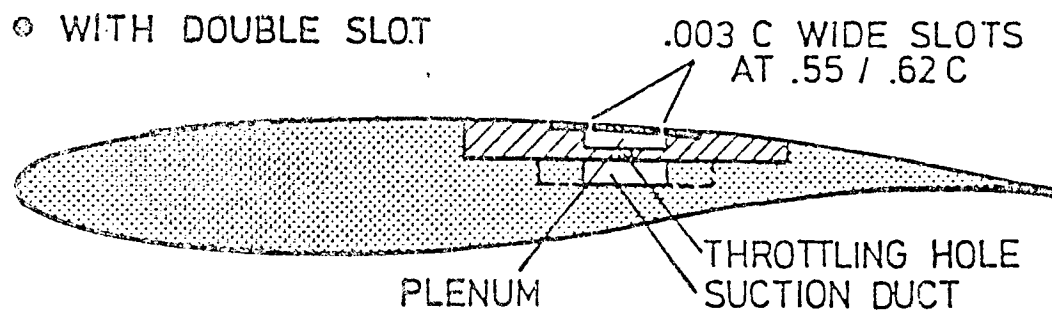

⊙ WITH PERFORATED STRIP

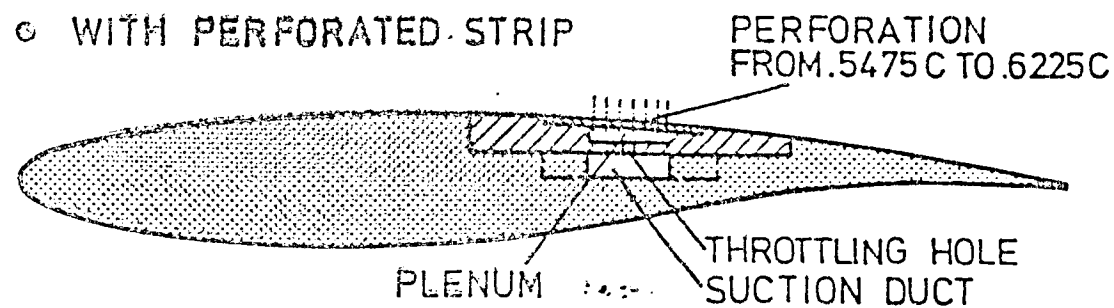

Fig. 11 : MODEL CONFIGURATION WITH ACTIVE/PASSIVE BOUNDARY LAYER CONTROL

AIRFOIL VFW VA-2

WITH DOUBLE SLOT

$M_\infty = 0.78$ $Re_\infty = 2.5 \cdot 10^6$

FIXED TRANSITION
.3 / .25c , 180K

DATA

--○-- WITHOUT CONTROL

—●— WITH VENTILATION

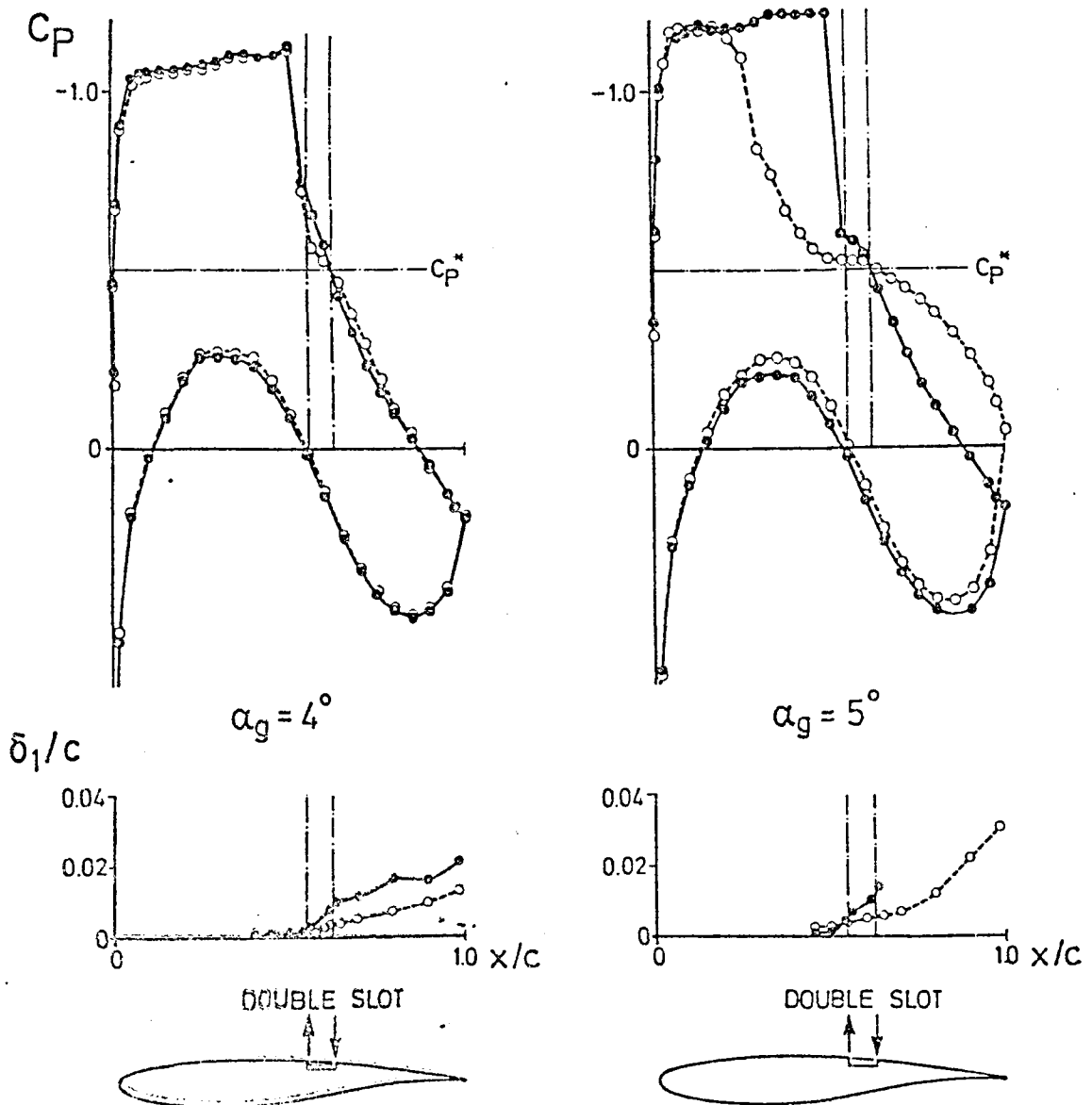

Fig. 12 : PASSIVE BOUNDARY LAYER CONTROL
THROUGH VENTILATION

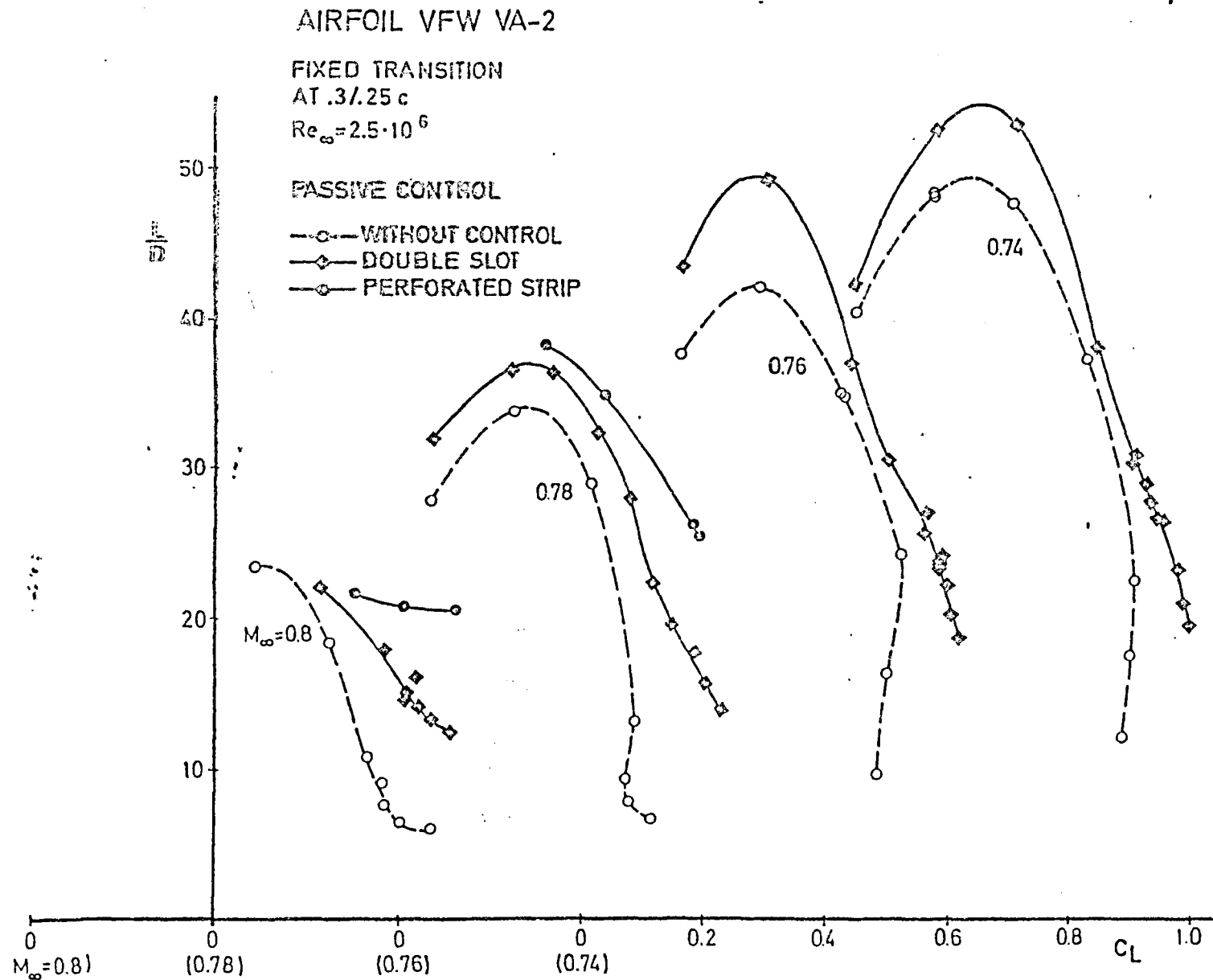

Fig. 13: EFFECTS OF THE PASSIVE BL CONTROL ON L/D NUMBER

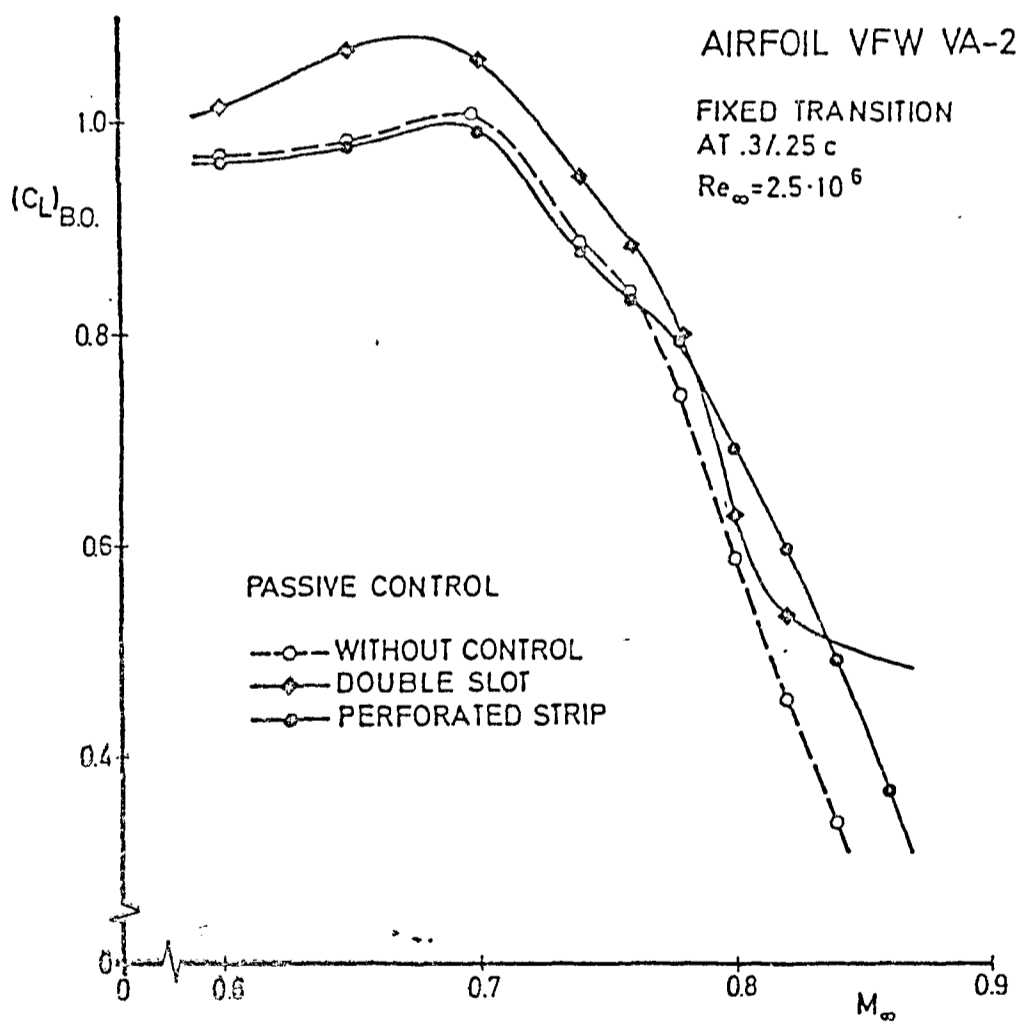

Fig. 14 : EFFECTS OF THE PASSIVE BL CONTROL ON THE BUFFET LIMITS

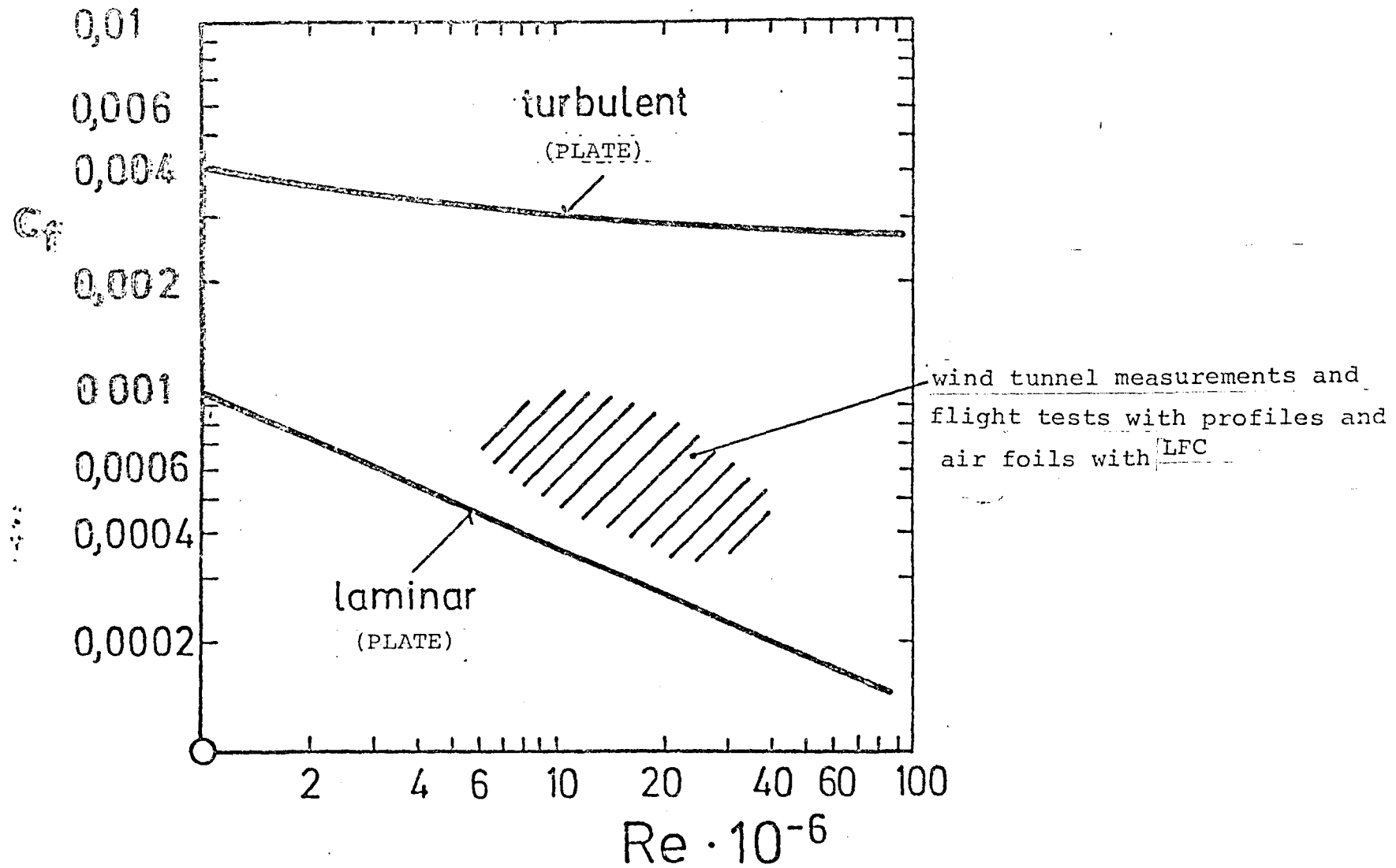

FIG. 15: FRICTION RESISTANCE OF LEVEL PLATE COATED ON ONE SIDE

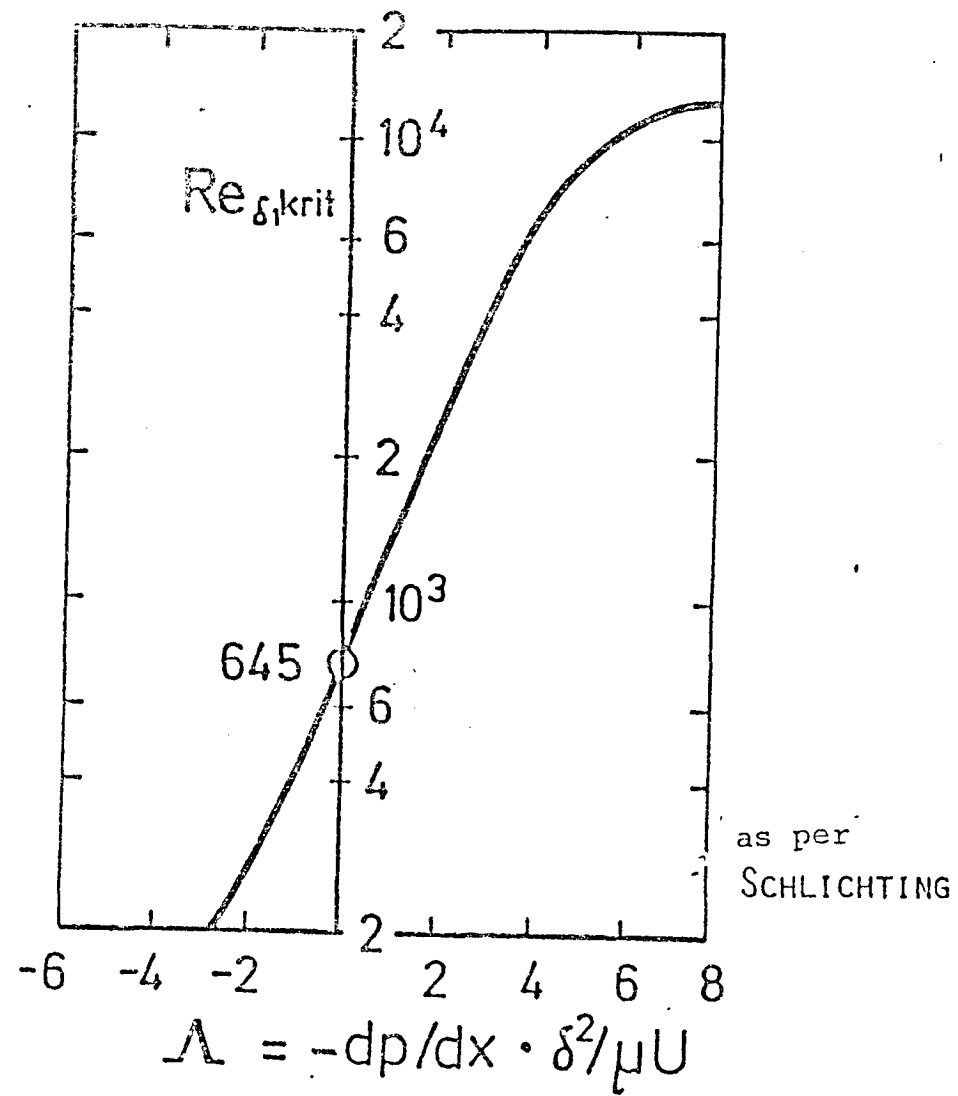
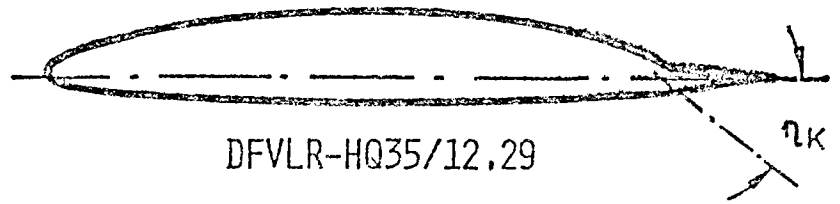
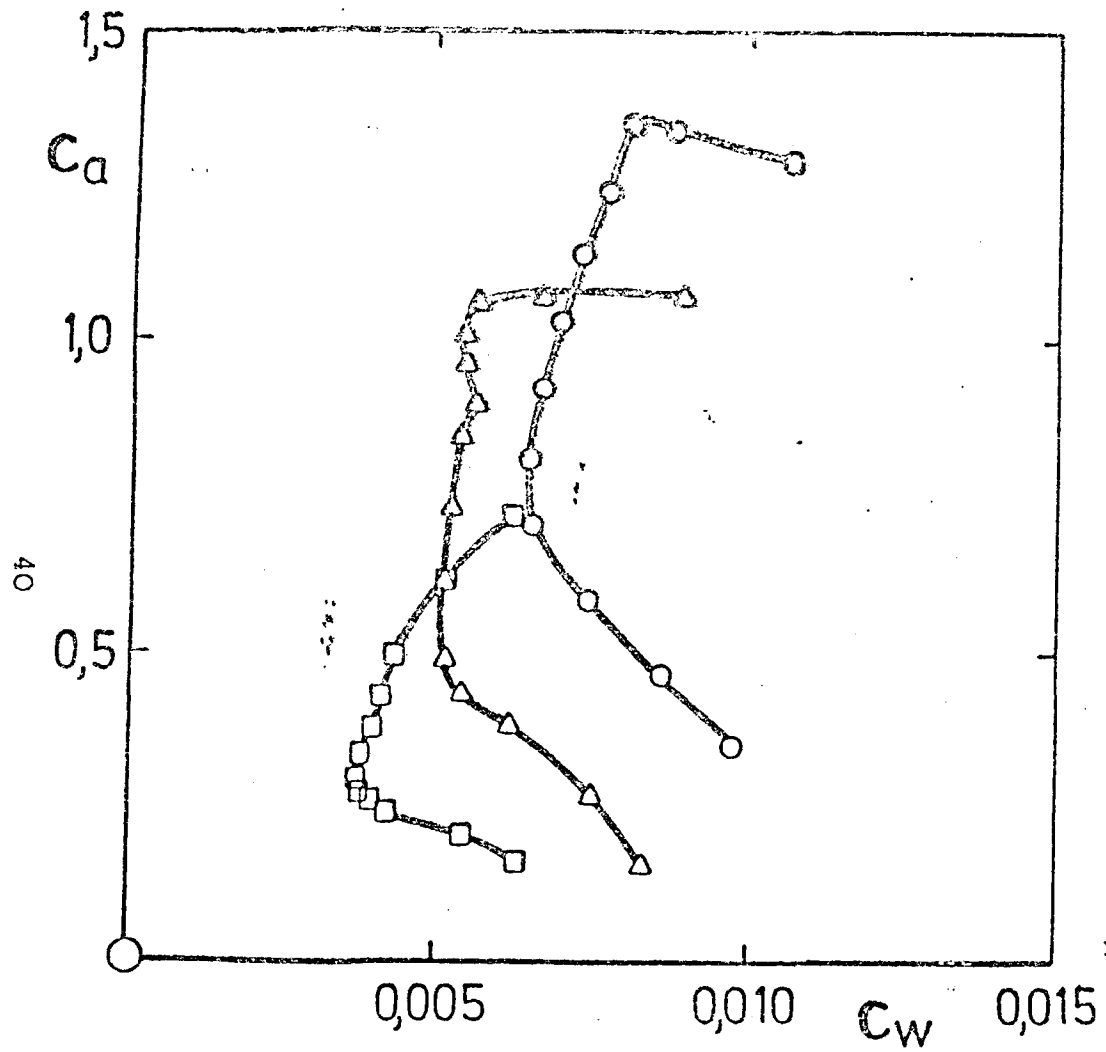

FIG. 16: RELATIONSHIP BETWEEN THE CRITICAL RE-NUMBER AND PRESSURE GRADIENT





SYMBOL	η_k	Re
○	20°	$1,0 \cdot 10^6$
△	10°	$1,5 \cdot 10^6$
□	0°	$3,0 \cdot 10^6$

measured at: laminar wind tunnel of TH Delft

FIG. 17: RESISTANCE PARAMETERS OF THE FLAP PROFILE



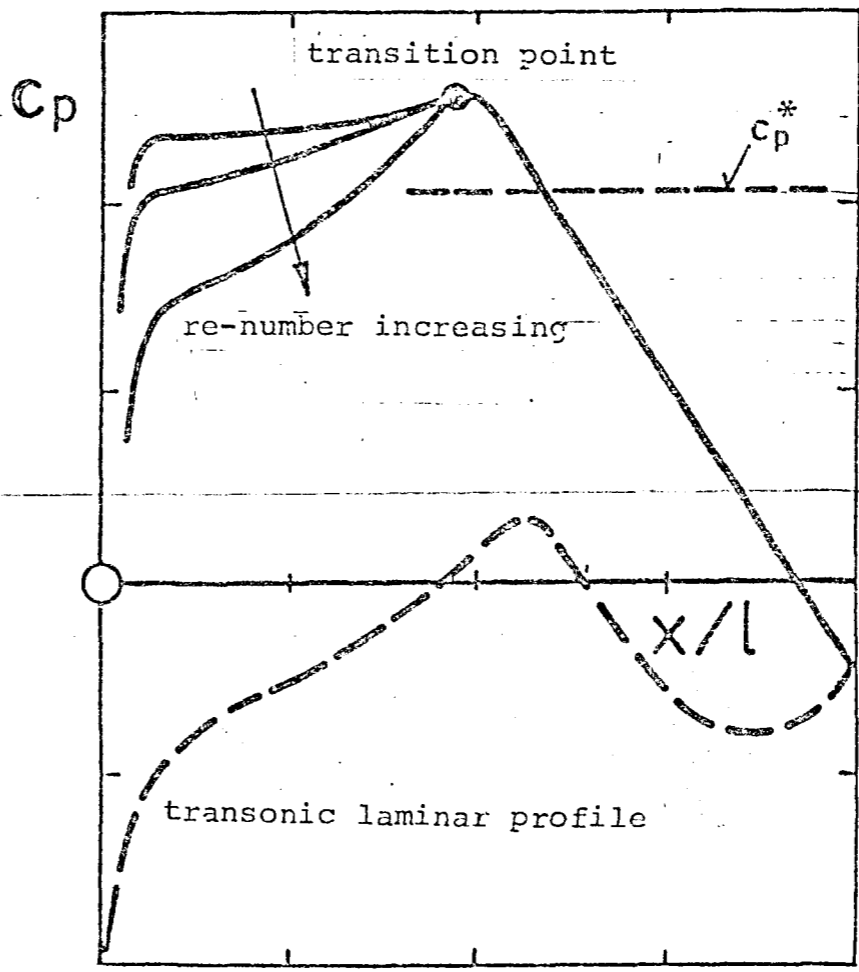
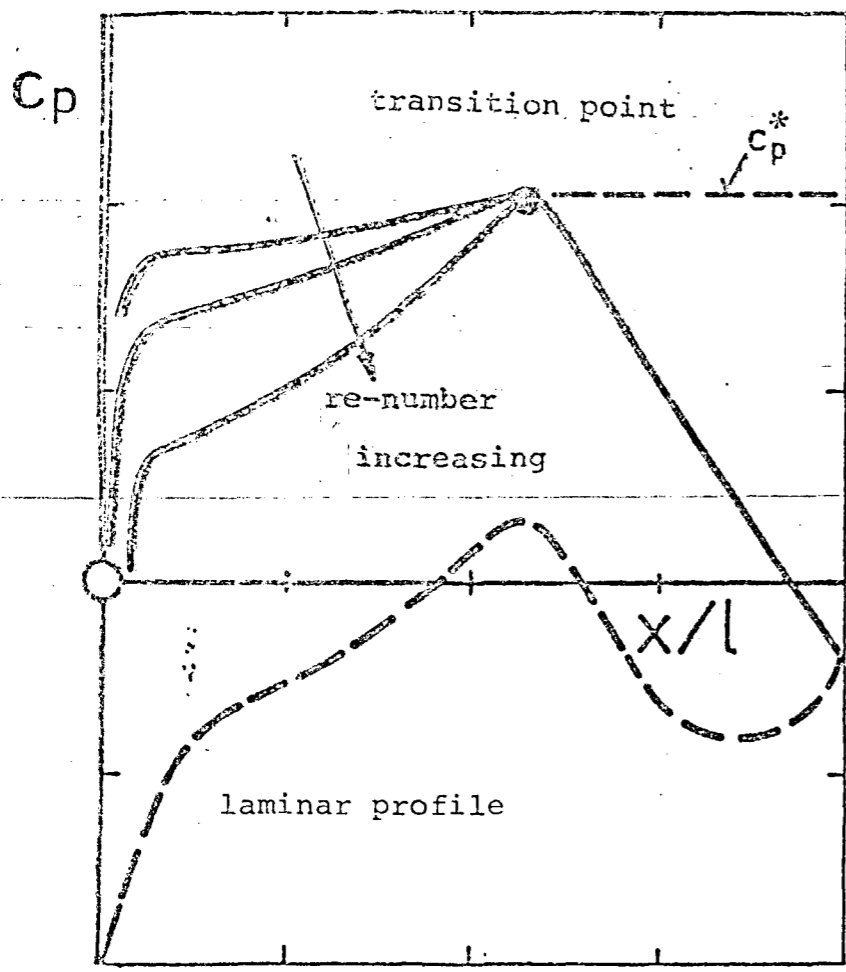

FIG. 18: REQUIRED PRESSURE DISTRIBUTION FOR LAMINAR PROFILES OF TRANSPORT PLANES WITH HIGH RE-NUMBERS



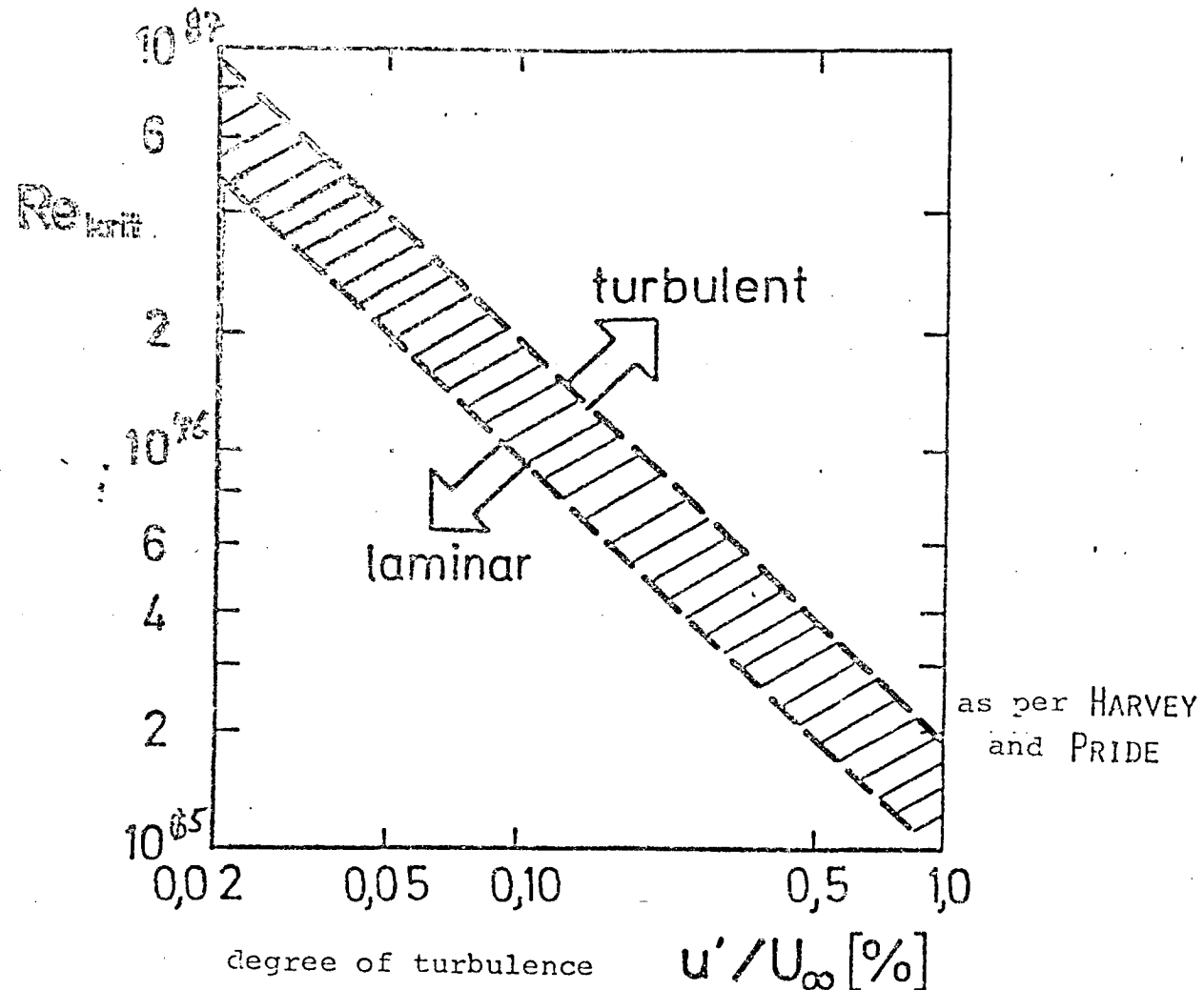

FIG. 19: RELATIONSHIP BETWEEN CRITICAL RE-NUMBER AND DEGREE OF TURBULENCE



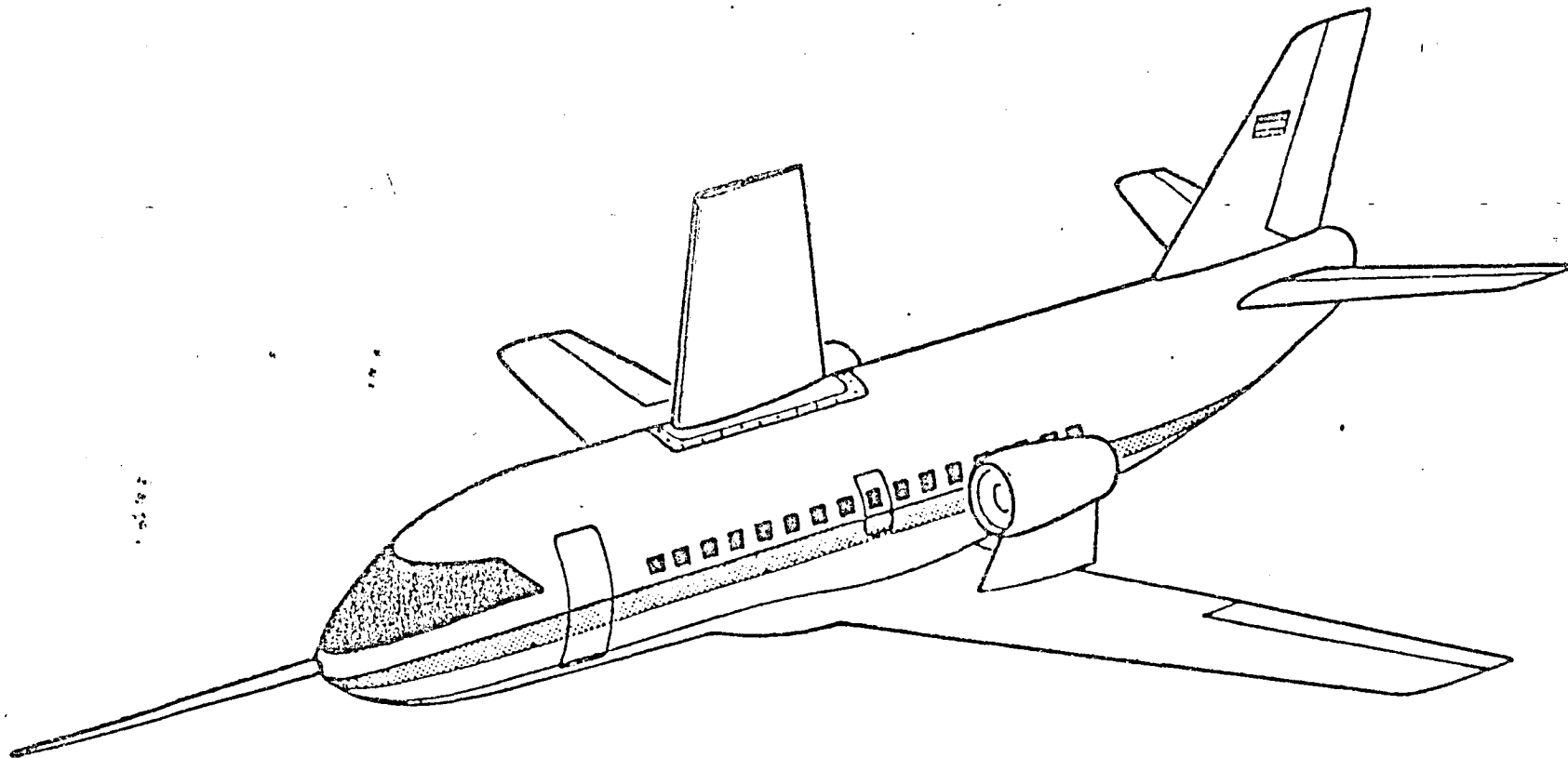

FIG. 20; TEST PLANE WITH MODEL WINGS FOR THE STUDY
OF LAMINAR PROFILES



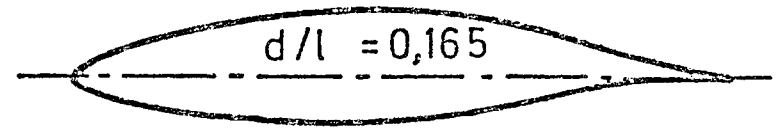
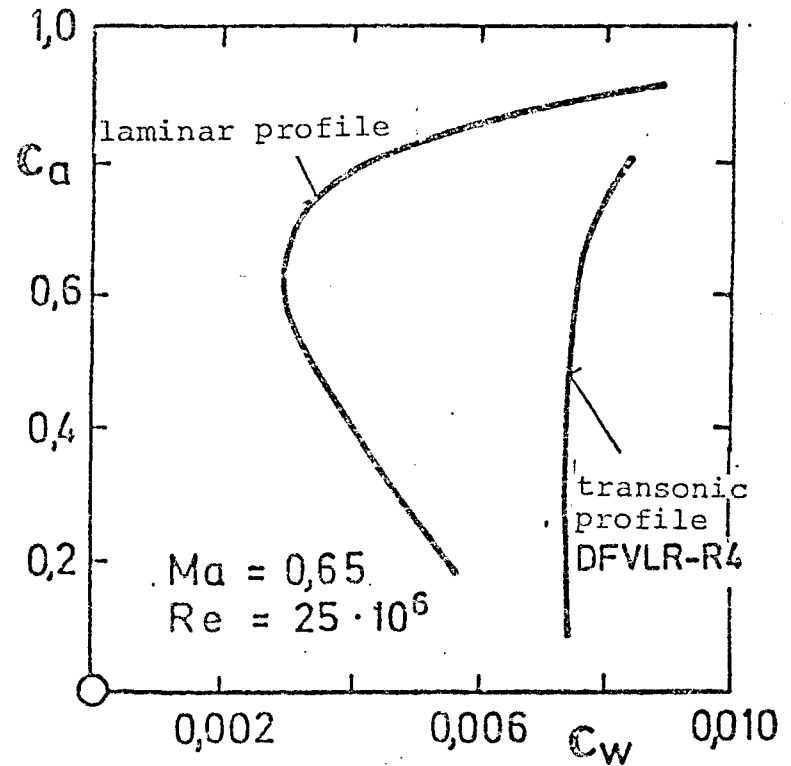
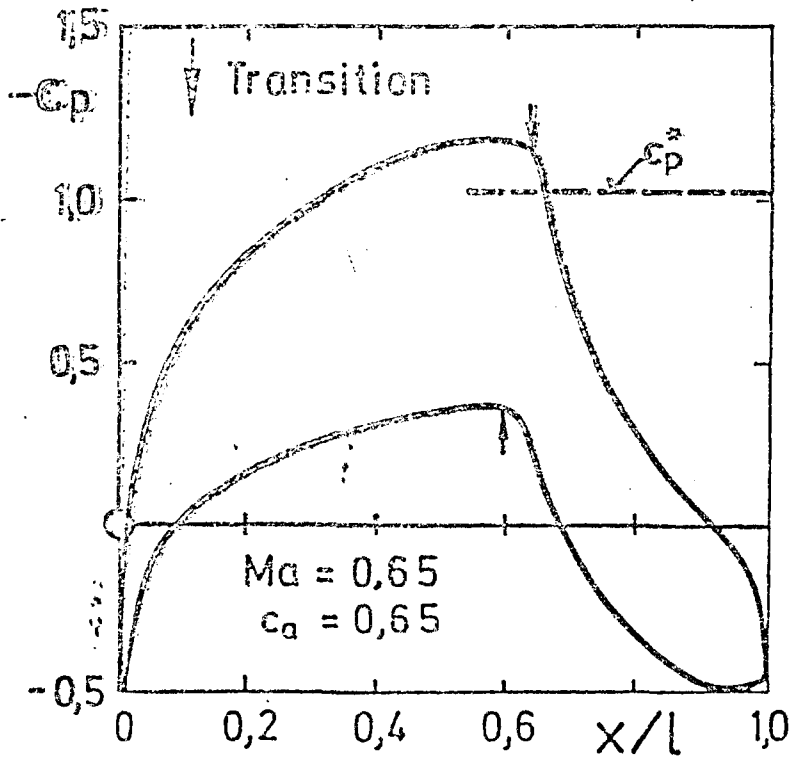

FIG. 21: RESISTANCE PARAMETERS AND PRESSURE DISTRIBUTION OF A LAMINAR PROFILE FOR A SUBSONIC TRANSPORT PLANE



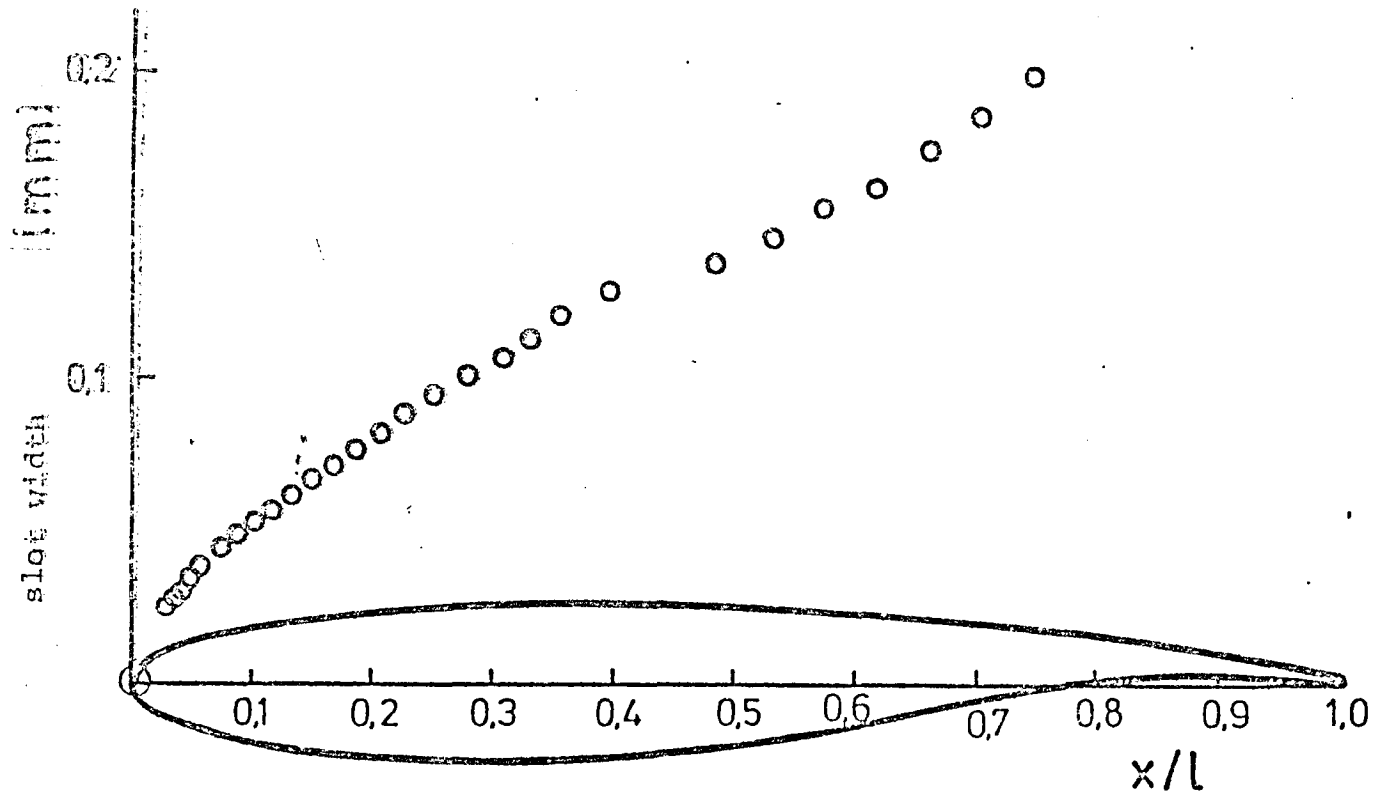
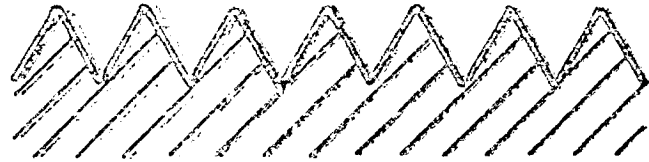

FIG. 22: ARRANGEMENT AND WIDTH OF SLOTS OF THE DFVLR EXPERIMENT



Riblets

$\circ U_{\infty}$



LEBU

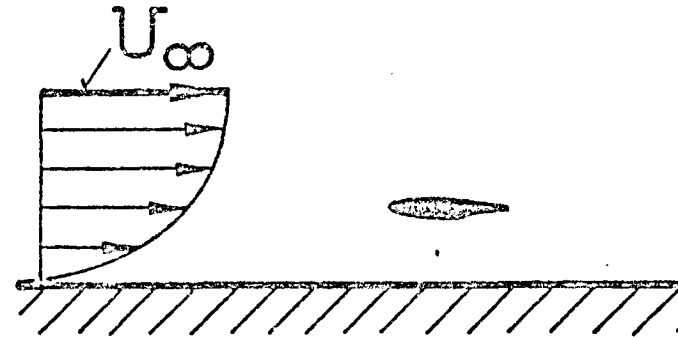

$\circ U_{\infty}$

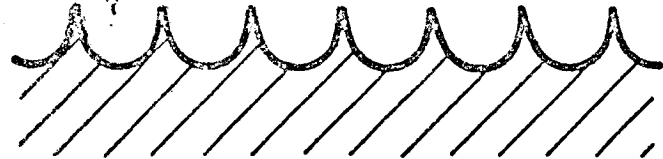

FIG. 23: RIBLETS AND LEBUS FOR THE REDUCTION OF TURBULENCE RESISTANCE



	ELEKTRA PROPELLER	PROP-FAN
number of blades	4	8
relative diameter	1.9	1.0
blade tip speed	220 m/s	245 m/s
⁴⁷ blade thickness(D/L)		
at the blade tip	0,03	0,02
at R/R = 0,25	0,2	0,12
circular disc stress	80 kW/m ²	300 kW/m ²

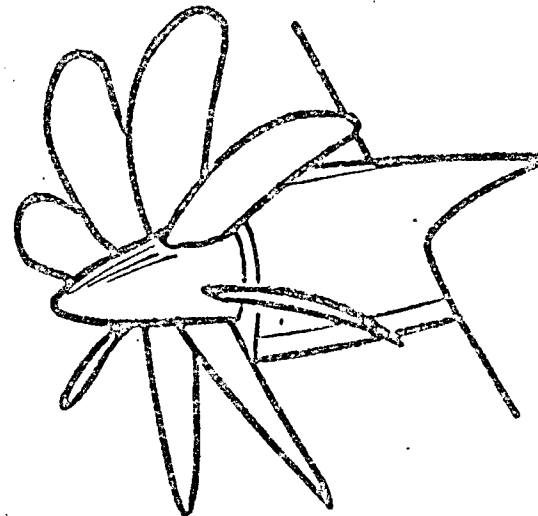
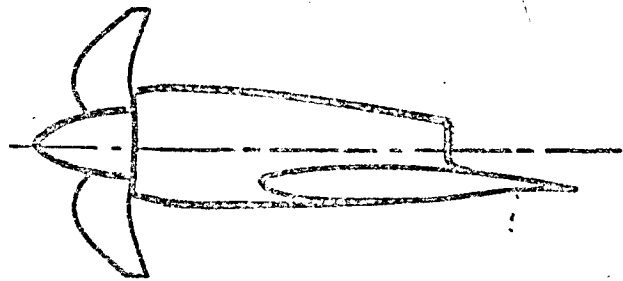
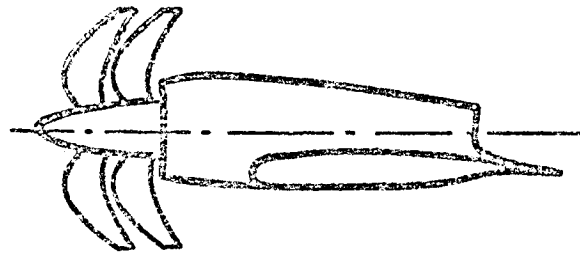

FIG. 24: CHARACTERISTIC DATA OF A PROP FAN





Prop - Fan



coax - Prop-Fan

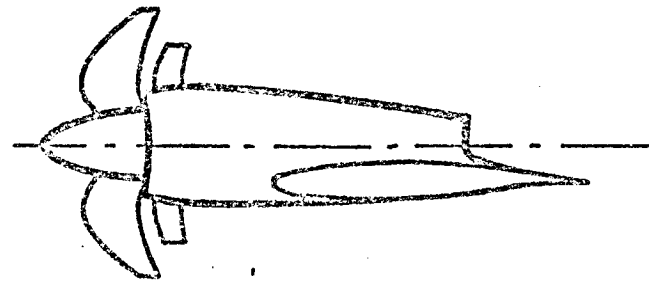

Prop-Fan
with Stator

48

FIG. 25: PROP-FAN VARIETIES



integration of the prop-fan
into the airframe

noise emission

flutter and fatigue
fracture safety

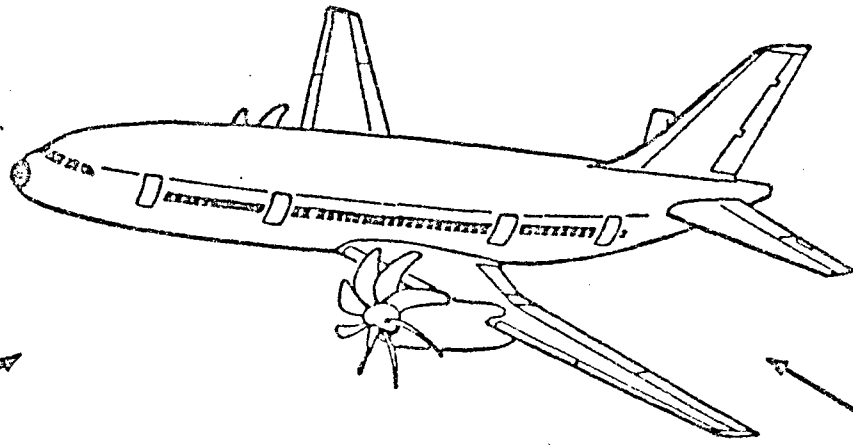

aerodynamic design
of prop-fan

availability of a suitable
propulsion system

FIG. 26: PROBLEM ZONES OF THE PROP-FAN DRIVE



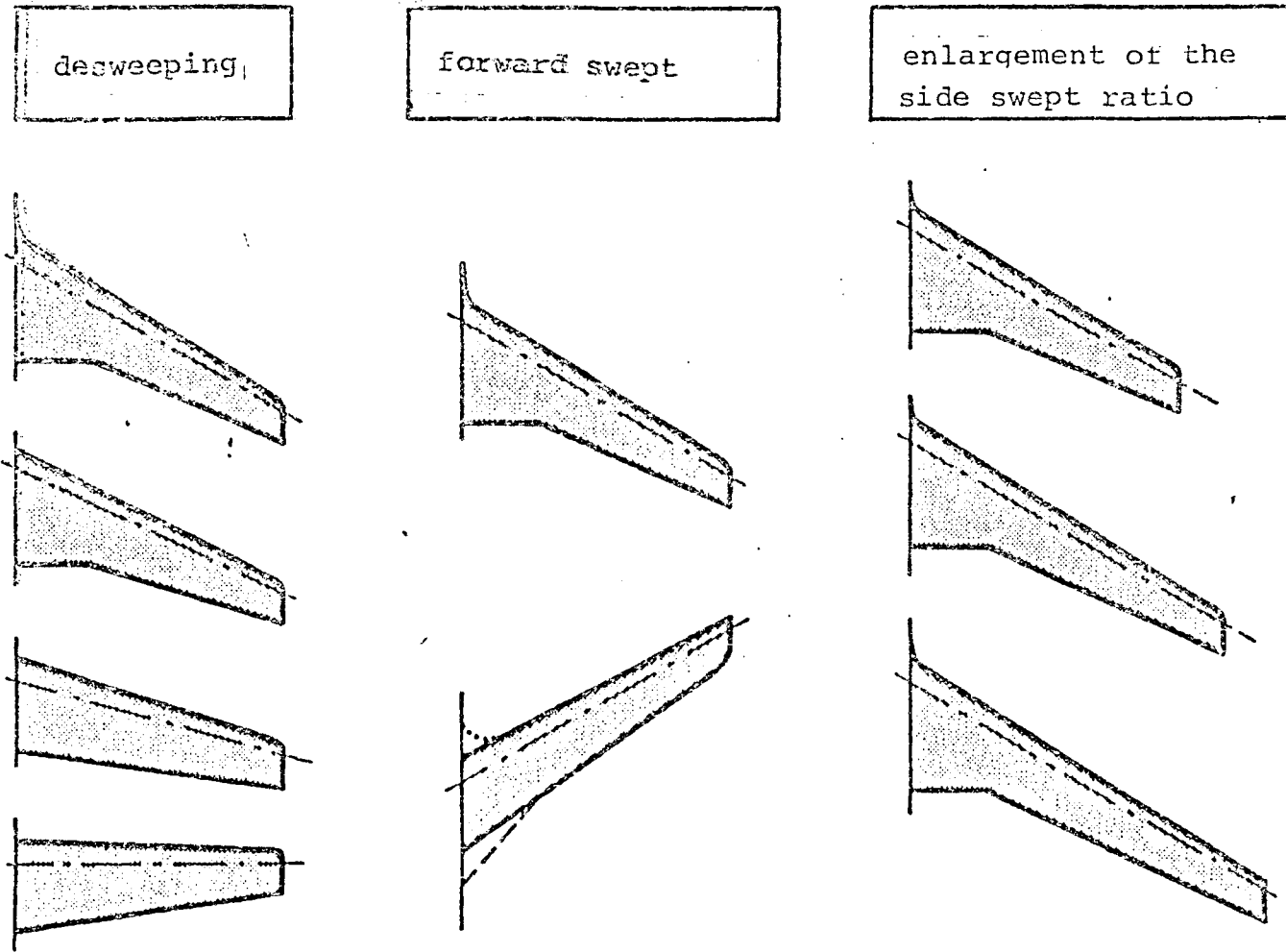

FIG. 27: CHANGES IN THE WING DESIGN



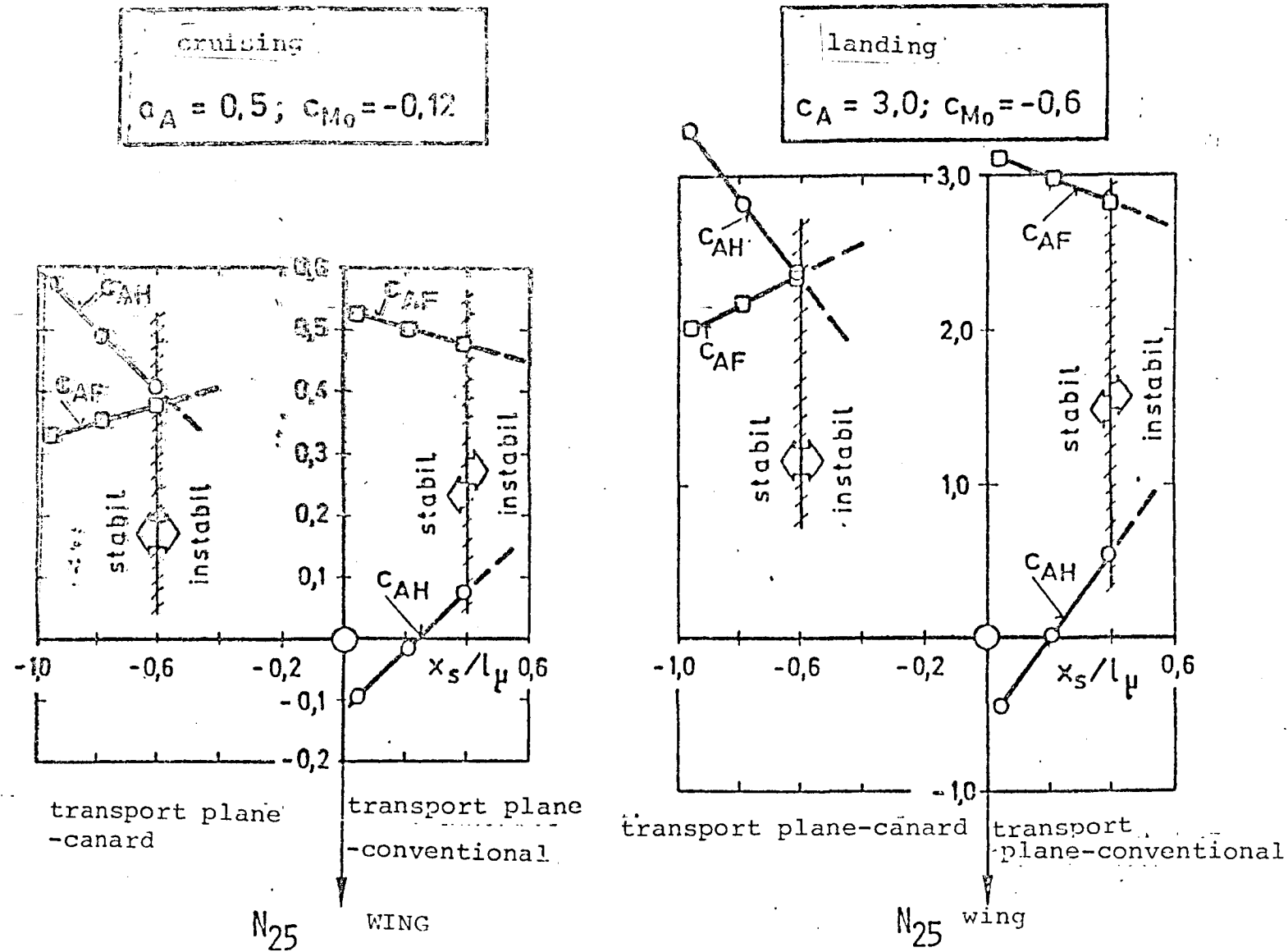

FIG. 28: UPLIFT DISTRIBUTION OF A WINGED TAIL ASSEMBLY WITH CONVENTIONAL AND WITH CANARD ARRANGEMENT



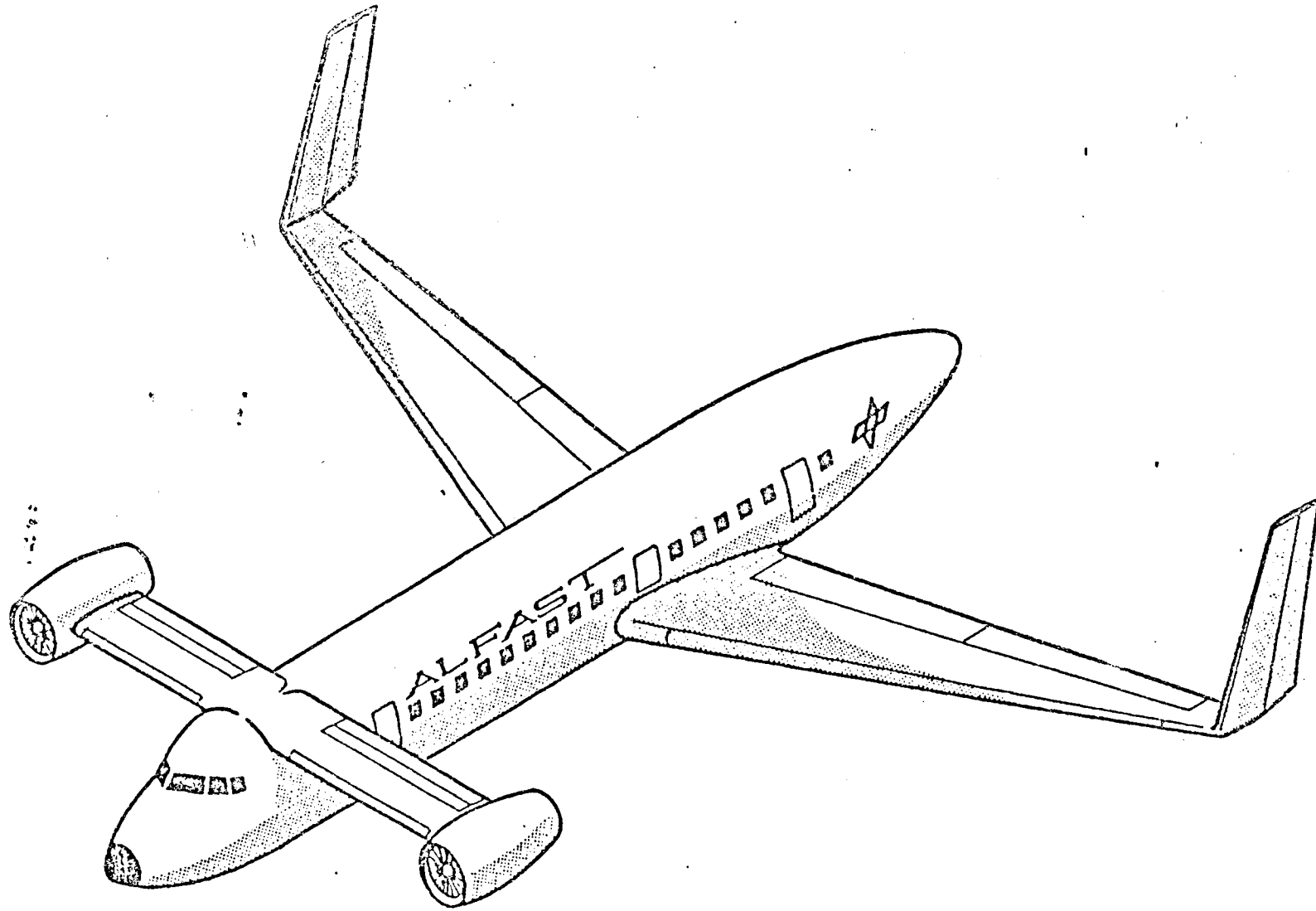
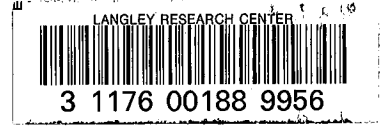

FIG. 29: CANARD CONFIGURATION WITH FORWARD ENGINES





LANGLEY RESEARCH CENTER



3 1176 00188 9956