

NASA Technical Memorandum 87201

Technology Achievements and Projections for Communication Satellites of the Future

James W. Bagwell
Lewis Research Center
Cleveland, Ohio



(NASA-TM-87201) TECHNOLOGY ACHIEVEMENTS AND PROJECTIONS FOR COMMUNICATION SATELLITES OF THE FUTURE (NASA) 13 P HC A02/MF A01

N86-17595

CSC 17B

Unclas

G3/32 05273

Prepared for the
11th Communications Satellite Systems Conference
sponsored by the American Institute of Aeronautics and Astronautics
San Diego, California, March 16-20, 1986



TECHNOLOGY ACHIEVEMENTS AND PROJECTIONS FOR COMMUNICATION SATELLITES OF THE FUTURE

James W. Bagwell
National Aeronautics and Space Administration
Lewis Research Center
Cleveland, Ohio 44135

Abstract

Over the past five years, NASA has conducted an extensive program to advance the state-of-the-art in communication satellite technology. NASA is preparing to conduct a flight experiment in 1989 to verify the performance of this technology. Shortly thereafter, we should see the communications satellite industry begin to use this technology and enter into a new era of satellite communications including services in a new communications band, 30/20 GHz.

What new capabilities and services does this NASA developed technology enable? What does the future hold for even better systems and services and what technology barriers must be overcome to enable these to happen? This paper addresses these questions by describing the accomplishments of the NASA sponsored technology program over the past five years and projecting possible technology advancements over the next 10 yr. A systems scenario for the year 2000 using this technology is described. The projected capabilities and systems described herein are based on technology advancements alone, without consideration for competing terrestrial technologies or market demand. These and other factors may affect the rate of development and characteristics of future satellite communications systems.

Multibeam systems of the future using monolithic microwave integrated circuits to provide phase control and power gain are contrasted with discrete microwave power amplifiers from 10 to 75 W and their associated waveguide feeds, phase shifters and power splitters. Challenging new enabling technology areas include advanced electro-optical control and signal feeds. Large scale MMIC's will be used incorporating on chip control interfaces, latching, and phase and amplitude control with power levels of a few watts each. Beam forming algorithms for 80° to 90° wide angle scanning and precise beam forming under wide ranging environments will be required.

Satellite systems using these dynamically reconfigured multibeam antenna systems will demand greater degrees of beam interconnectivity. Multi-band and multiservice users will be interconnected through the same space platform. Monolithic switching arrays operating over a wide range of RF and IF frequencies are contrasted with current IF switch technology implemented discretely. Size, weight, and performance improvements by an order of magnitude are projected.

On-board message processing will advance to the state where it will be fully autonomous incorporating in-band signaling, very high speed switching and routing, and universal demodulation. These will be contrasted with the current technology to be demonstrated on the Advanced Communications Technology Satellite in 1989, using separate orderwire signaling, single format demodulation and complex high power message storage systems.

Very high speed, low power, radiation tolerant semiconductor technologies will be required for implementing the advanced architectural concepts.

A system scenario of the future may likely include a wide array of user terminal types manufactured for mass market consumer sales plus building block components for existing terminal upgrades. Equal access services will be generally available from customer owned terminal equipment. New satellite and Earth station technologies will be both adaptive and programmable to minimize obsolescence and better assure compatibility of existing and emerging services.

Introduction

NASA's program in communication satellites began early in the nation's space program. Every major advance in satellite operation has been preceded by a significant technology development by NASA. Having had its communications R&D program reduced to a low ebb for approximately five years during the latter part of the 1970's, NASA now finds itself again making major advances in communication satellite technology. The capabilities these advances have enabled to date are impressive, but the prospect for the future is even brighter. The possibilities are just hinted at in NASA's current and planned activities. The future undoubtedly holds many things yet unforeseen and unimagined. The technology advances required are realizable, but attention must be given to identification of the most promising and affordable ideas.

Background History

From its beginning years, NASA was looking toward the exploitation of the unique characteristics of space. It all began with the launching of Echo in in the early 1960's, a large balloon in space from which radio signals could be reflected back to Earth. This led, in 1963, to the launching of the first active transponder satellite, a spinner. This was followed by a series of experimental spinning satellites, Syncoms. These early demonstrations, led to the launch in 1965 of a commercial Syncom look-alike, the Early Bird (or Intelsat I). In 1966 NASA again took the lead in satellite communications technology with the launching of a series of Applications Technology Satellites, ATS. ATS 1 to 5 featured a despun antenna and a C-band transponder in addition to transponders at VHF and L-band. These early ATS satellites triggered the development of the whole series of commercial satellites beginning with the INTELSAT 3 series and including WESTAR, COMSTAR, TELSTAR, SATCOM, and now GALAXY. In 1974, NASA launched the first in a series of 3-axis stabilized satellites in ATS-6. This too fostered a whole series of 3-axis stabilized commercial satellites to follow. These included INSAT, ARABSAT, and TDRSS.

As always, NASA had its eyes on the future and foresaw the need for communication satellites capable of high-radiated-RF-power. To this end the Communications Technology Satellite, CTS, was jointly developed with the Canadian government. This project sought to advance the technology of both space and ground-based components and systems capable of high power in space and lower cost in the ground segment. This satellite, launched in 1975, for the first time, introduced satellite communication in the Ku-band. Again, as predicted, commercial ventures picked up on NASA's lead and began a series of Ku-band satellites in 1980 with the launching of SBS followed, up to the present, with SPACENET and SATCOM with more yet to come. In the meantime, unfortunately, National priorities and a mistaken appraisal of the capabilities of U.S. industry to assume the long range, high risk technology development sponsored by NASA, caused NASA's R&D in communication satellites to be significantly cut back in 1973. With NASA pursuing an aggressive manned space program, the continued development of the advanced technology crucial to the future of the emerging satellite communications industry in the U.S. fell solely to a still maturing industry. However, this was not the case overseas. European and Japanese companies saw the opportunity and began to move out with communications R&D sponsored, in part, by their respective governments.

With the use of satellites for domestic voice, data, and video traffic increasing at a rate likely to exceed the capacity of the C and Ku bands within a decade the attention of the U.S. government was drawn to finding a solution. This prospect, coupled with the emerging problem of international technology and trade disparities was recognized in 1978 and President Carter saw fit to reinstate federal sponsorship of commercial communication satellite technology. This directive (PD-42 in October 1978) was quickly followed by an aggressive new NASA program in advanced R&D in satellite communication with the initiation of a 5 yr technology program aimed at opening the Ka-band to commercial use along with new on-board technologies of multi-beam antennas and satellite switching and processing.

Advanced Technology Program Overview

Over the past six years NASA has been pursuing a comprehensive, coordinated program in multibeam communications satellite technology as described in Ref. 1. Although aimed at enabling use of the Ka band of frequencies, specifically 30/20 GHz, the technology program included numerous elements of multibeam, processing, and switching technologies which are truly frequency independent. The overall goal of the advanced communications satellite technology program is to develop and introduce new technologies to an extent that all excessive risks have been removed or reduced to a sufficiently low level that the commercial satellite industry will not hesitate to use them when the need arises. To date, this technology program has completed development of the wide array of functional components and subsystems shown in Table 1. These developments were conducted by the companies shown under NASA sponsorship and now are being tested³⁻⁵ and integrated into a communication system test bed at NASA. When completed in 1987, this test bed, functionally depicted in Fig. 1 and described in Ref. 2, will be capable of emulating

a satellite based communications network including ground terminals and the intervening RF paths. Ground testing of this sort is believed to be adequate in removing excessive risk to using new technology in many instances. Where this approach is not sufficient, a flight experiment program is conducted to remove or further reduce the remaining risk factors. This is currently the case in the advanced technology program and hence, the initiation of the Advanced Communications Technology Satellite (ACTS) Project. The goal of the ACTS project is to further reduce or remove the risks associated with the use of multiple scanning and fixed beam antenna systems and the many elements of on-board processing and routing needed to interconnect the multiple beams. Performing this flight experiment at Ka-band serves the additional purpose of verifying successful operation in the new band. Following its launching in 1989 and a two year experiment period to follow thereafter, it is expected that development and deployment of commercial Ka band satellites will begin.

In the meantime, the advanced technology development program is continuing to identify new goals and objectives and pursue a course aimed at further accomplishments of significance in the future. In the paragraphs to follow, many of the accomplishments to date will be described along with planned extensions and new technology initiatives.

Low Noise Receivers

The development of 30 GHz, low noise, satellite based receivers was undertaken with dual contract awards. Both pursued an approach using an image enhanced mixer design believing it to be premature to attempt a design using 30 GHz FET LNA's. Both achieved all performance goals except that the noise figures exceeded 5 dB. In this case, available technology has already surpassed this goal. The ACTS flight experiment will employ low noise receivers with a noise figure of 5.0 dB using FET LNA's. Microwave monolithic integrated circuit (MMIC) receivers at 30 GHz are currently under development. The configuration of a typical receive module is shown in Fig. 2. These are targeted for phased array antenna use which will be described later. The anticipated noise figure for these is 5.0 dB.

Recently the development of a 20 GHz low noise receiver for ground station use was undertaken. This is a mostly monolithic receiver with goals of low cost design and a noise figure of 3.5 dB. It is anticipated that the use of monolithic techniques will allow for substantial reduction in the cost of 20 GHz ground terminal receivers when manufactured in quantity. It is likely that monolithic 30 GHz receivers along with emerging phased array antenna technologies will minimize the use of single on-board receiver applications in the future.

High Power Amplifiers

Both tube and solid state amplifiers at various frequencies have been under development for many years. The satellite industry is already employing solid state amplifiers at C-band and may soon do so at Ku-band. Since a characteristic of solid state devices is decreasing output power and efficiency with increasing frequency, the

demonstrated performance to date at 20 GHz has been poor. First attempts at solid state amplifiers resulted in 15.8 W at 13 percent efficiency for an IMPATT amplifier and 8.2 W at 8.5 percent efficiency for a GaAs FET amplifier. Combiner efficiency appears adequate but the combination of large numbers of devices results in a decrease in bandwidth. The bandwidth achieved for the IMPATT amplifier was less than 100 MHz and for the GaAs FET amplifier 1.7 GHz both less than the desired goals of 500 MHz and 2.5 GHz respectively.

Higher power devices would require fewer in combination for the same power output. A follow-on device development program has resulted in IMPATT devices at 4.3 W and 19 percent efficiency and GaAs FETs at 1.0 W and 23 percent efficiency with a 1.5 GHz bandwidth. A further effort to get a 2 W FET led to a device with only 18 percent efficiency and a 1.0 GHz bandwidth.

At the same time, TWT development has been proceeding with continued modest gains in performance which already exceeds solid state performance by nearly a factor of two. Tubes with 50 to 75 W output at 60 percent efficiency with 2 GHz bandwidth are being projected combining the new techniques of diamond supported helices, graphite depressed collectors and variable pitch helices. Reliability, once the great risk of TWT amplifiers, has been greatly improved in recent years with the development of M-type dispenser cathodes and open-to-vacuum construction techniques. The M-type cathode has demonstrated a 10 yr lifetime potential on life test. While high voltages will always pose a reliability threat, open to vacuum construction and fault tolerant design have greatly reduced the potential for failure. While tubes remain the performance choice at higher power levels, the solid state amplifier as a tube replacement at 20 GHz appears probable up to approximately 20 W.

In the future, NASA will continue to improve TWT performance to meet or exceed the projected goals. On the other hand solid state devices appear to be reaching the point where performance gains are diminishing. Thus NASA's development efforts in solid-state in the future will be focussed to a large extent on MMIC power modules for phased array antenna applications. Figure 3 shows a possible configuration for a typical MMIC power module including an integral phase shifter.

In the area of ground station power amplifiers efficiency is not nearly as important a factor as is cost. Current tubes of the coupled cavity or helix design are very costly to fabricate. New design techniques such as the tunnel ladder technique are being pursued as a means of reducing manufacturing costs. Meanwhile, NASA had sponsored a 30 GHz solid state amplifier using silicon technology. The amplifier produced 20 W at 9 percent efficiency and 260 MHz (1 dB) bandwidth. Here again, solid state amplifiers will likely grow to dominate the lower power applications and because of the lesser sensitivity to efficiency, likely be applied at higher power levels than its spaceborne counterpart.

Multibeam Antenna

The primary new technology begun in 1980 was that of the multibeam antenna. Using clusters of waveguide fed horns both fixed and scanning spot

beams were developed. The fixed spot beams were positioned to provide spatial separation between areas of high communications traffic density. To provide coverage over the less-dense areas of CONUS the scanning spot beams were employed, providing time separation between covered areas. Adding polarization to these techniques allowed interference free spots to be even more closely spaced resulting in as much as 12 times frequency reuse across CONUS.

Two parallel contracts were awarded for the development of the first satellite antennas to incorporate a combination of scanning and fixed beams. Both contractors considered it premature to attempt a development using MMIC device technology and thereby constrained their efforts to corporate feeds using waveguide power dividers and phase shifters. The complexity of a typical three-beam horn cluster is shown in Fig. 4. Even though only small subsets of an operational six scanning beam, 18 fixed beam system were built, considerable difficulties were encountered in the fabrication of the complex waveguide structures. It was generally agreed that, although the required performance was obtained, fabrication of an operational sized system was impractical.

As previously stated, solid-state power amplifiers to feed these multibeam antennas have required large numbers of low power, 1 to 2 W, devices to be combined thereby diminishing overall performance and efficiency. A typical power amplifier would then be connected through power dividers and phase shifters to a multi-horn cluster for proper beam forming. Each horn might require only 1 to 2 W for adequate performance in rain-free conditions. If a separate amplifier of this power could be developed to directly feed the radiating horn or alternately perform as a direct radiating element then the complexities and losses of the waveguide beamforming network and the mismatches of the combiners within the power amplifier could be avoided. These losses are broken out in Fig. 5. It was on these premises that research in MMIC power and receive modules was begun. Although multiple contracts were awarded in the early 1980's for both 20 GHz power modules and 30 GHz low noise amplifiers, both incorporating variable phase shifters, it wasn't until 1985 that successful module performance was demonstrated. The concept for using such modules in an antenna is shown in Fig. 6. An experimental array antenna using the 20 GHz power modules is now under construction with construction of 30 GHz receive feed system scheduled to begin in 1986.

Once the ability to exercise virtually infinite control over the formed beam is realized, then additional capabilities accrue to the designer. Most exciting of these is the possibility of correcting beam anomalies created by a mechanically or thermally distorted reflector. The effects of such distortion are graphically shown in Fig. 7. By either measuring the antenna distortion or sensing the beam distortion the on-board antenna controller can be programmed to impose corrections to the phase and amplitude of each radiating element to restore proper beam performance. The use of this technique will enhance the performance of larger, deployable antennas on the spacecraft. These larger antennas could then lead to the use of lower frequencies and/or smaller spot beams.

On-Board Switching

Once having developed the concept of multiple antenna beams for both up and down links it became obvious that new methods had to be devised to interconnect these beams in the proper order. The first of these techniques took the form of dynamic matrix IF switches. Again, two parallel contracts were awarded both pursuing the common approach of coupled, crossbar matrix switching using dual FET switches at each crosspoint. Differences were principally in the areas of packaging and circuit layout. 20 by 20 matrix switches were required for POC demonstration with a growth potential to 100 by 100. Because of cost, the crosspoints were only partially populated with couplers and active switching elements. A picture of one such switch matrix is shown in Fig. 8. The size of such a switch assembly approached 2000 in³ including switch drivers. Though the best design practices were used these discretely implemented switches were bulky and imposed path losses from 13 to 27 dB or varied over a 10 dB range in a single switch matrix. It was therefore concluded that a 100 by 100 matrix was impractical by these or similar techniques using discrete parts.

To solve these problems, NASA is sponsoring a technology development effort to implement a switch matrix in MMIC. The first of these is targeted at producing a 10 by 10 IF switch matrix with 0 dB insertion loss. Fabrication of such a design appears possible on a 1/2 by 1/2 in. MMIC substrate. Additional work has recently begun using the same approach but at 20 GHz. Such a switch would require only a single down conversion from 30 to 20 GHz thereby eliminating the upconverter which would normally follow the matrix switch. With the availability of a basic 10 by 10 building block in MMIC, the expansion to 100 by 100 should easily follow.

On-Board Processing and Routing

The second multibeam interconnection technique to be developed was the baseband processor. This initial development embodied the followed capabilities: demodulation, decoding, store and forward routing, encoding, and modulation. The proof-of-concept system could accommodate burst rates from 27.5 to 550 Mbps. Internal message storage used 120 nsec CMOS memories thereby necessitating the use of 64 bit serial to parallel and parallel to serial converters to accommodate the slow memories. Burst demodulators were developed using a combination of discrete and LSI techniques implementing a minimum shift keying (MSK) concept. Coding was implemented in LSI with a single CMOS decoder chip providing 10.2 dB gain at 13.75 MBPS using a 1/2 rate, constraint length 5 convolutional code.

This first attempt at a full-up baseband processor served to baseline the necessary technologies. As a result, demodulators, decoders, rad hard memories, support circuits, and architecture have been identified as needing further investigation and technology improvement. NASA has undertaken the development of GaAs parallel to serial and serial to parallel converters at rates in excess of 550 Mbps with a required power goal to be 250 mW, one fourth that of the ECL previously used. This development is hoped to be only a stop gap measure until faster memories can be developed. Memory access times of 5 nsec or less would be

highly desirable. Should a memory of this speed become available it makes possible developing a processor architecture without converters previously needed to slow data accesses to the memories.

Another problem arises as more and more message processing, control, and intelligence are placed on-board the satellite. Most of these functions become feasible only if LSI or VLSI techniques are employed. An operational system in present day technology would consume almost 1 kW. Thus, a low power semiconductor technology is also desirable. Both higher speed and lower power can be achieved with smaller feature sizes (0.25 to 0.5 μm) but care must be taken to avoid increasing susceptibility to radiation induced SEU.

An area yet to be seriously penetrated by technology is modulation and coding especially for high rate bursted data. In a typical advanced satellite communications scenario using time division, multiple access (TDMA) techniques network timing and synchronization must be maintained to within a fraction of a microsecond. Bursts of data arriving at the satellite from many different ground terminals are noncoherent, and low overhead data acquisition techniques must be developed. Systems are being conceived for the future where 1 Gbps burst rates may be desired. Given the environmental factors such as rain and its effects at the higher frequency bands being chosen, these requirements pose many problems for the developer of modems and coding. Since one of the reasons for moving to higher frequencies, such as the Ka band, is greater bandwidth to alleviate frequency congestion, higher modulation efficiencies are also desirable.

In an attempt at addressing this problem, NASA has recently begun a series of technology contracts aimed at developing advanced modems. These efforts have been divided into two categories, ground terminal and satellite modems, each with their own distinct requirements. Parallel contracts are being pursued in each area with common goals of 200 Mbps minimum with a minimum efficiency of 2 bps/Hz. Satellite modems are, in addition, to be small and power efficient while the ground terminal modems are to have the potential of low cost implementation. Each contract is to result in demonstrable proof-of-concept hardware. A subsequent effort is planned where one or more of the developed modems will be extended to VLSI implementation. The next stage in developing this technology will be to include techniques for accepting many different modulation formats, the universal modem. This feature will be extremely useful for satellite modems, allowing ground stations using many different types of modulation to access the same satellite.

In consideration of the aforementioned technology plans and needs, it appears appropriate that renewed attention be given also to new architectural concepts which could take advantage of the increased capabilities which will emerge. As new technologies permit higher performance components to be developed less parallelism should be required to handle the anticipated high data rates. In-band signaling should be realized in place of the separate, displaced in time, orderwire method now being employed. Worthy of consideration, also, may be the single string implementation of an independent function, such as an individual

input/output channel interconnected only via the routing switch. This modular approach may permit technology to advance apart from an orderly growth in capacity dictated by traffic demand.

Functions and Service Possibilities of the Future

In the preceding paragraphs some of the future technology trends have been identified. These, in turn, will open the door to functionally improved communication satellites and new services available to the public. These technologies, in combination, will permit the development of a complete space based communications message center. It will be multifrequency and multiservice. It will be able to provide full interconnectivity between conus beams and regional spot beams, large trunking users and small customers premise terminals. It will relay information from other satellites and space based platforms such as space station. Fully adaptable, fault tolerant systems will provide obsolescence free long life. Terminal sizes will range from an affordable 1 to 2 m terminal capable of a T-1 rate at a small business site to a large terminal at a regional trunking hub. Such a communications platform of itself or in conjunction with other platforms will be capable of integrating personal/mobile communications into the network.

The extent to which these and other services yet unforeseen will develop is uncertain. There will be continued competition with existing and emerging terrestrial communications systems such as fiber optics. Each will assume a complimentary role as new information systems and communications needs impose new and expanding service demands on the communications industry. Developing nations with their cultural differences, unique geography, and individual communication needs will contribute to an expanding world market.

Summary of Required Technology

Multibeam antennas and higher frequencies will provide solutions to the problems of frequency and orbit congestion in the future. Beam interconnection technologies of switching, processing, and routing will allow for the interconnection of large quantities of users in geographically diverse areas. All of these features point to a trend of increased on-board functions, a direct and possibly extensive departure from the bent-pipe transponder systems currently being employed. All of these depend on some major technology advancements in

the next five to ten years. VLSI and MMIC circuits will be extensively required. Highly reliable and fault tolerant, these circuits must assume physical and functional sizes larger than those available today.

Just now emerging from the research lab, new optical technologies may eventually solve some of the current problems in semiconductor performance and displace conventional techniques now being worked on. Their immunity to noise and radiation coupled with their wide bandwidth capability make them ideal candidates for the transmission, processing, switching, and routing functions outlined above. Although the possibilities are exciting, much work remains to be done. The technologies to support terrestrial fiber optics and satellite based optical systems may in fact have much in common, advances in one thereby benefiting the other.

With Government funding in key areas, U.S. industry remains in the competition, but has by no means overcome its foreign competitors. The right decisions to pursue selected high risk technologies remains NASA's priority in enabling U.S. industry to contend in the ever expanding domestic and foreign marketplaces.

Reference

1. Santarpia, D.E. and Bagwell, J.W., "Status of NASA's Multibeam Communications Technology Program," EASCON '83; Proceedings of the Sixteenth Annual Electronics and Aerospace Conference and Exhibition, IEEE, New York, 1983, pp. 53-68.
2. Bagwell, J., "A System for the Simulation and Evaluation of Satellite Communication Networks," Communication Satellite Systems Conference, 10th, AIAA, 1984, pp. 172-180.
3. Conroy, M.J., "Test Results for 27.5- to 30-GHz Communications Satellite Receivers," NASA TM-83662, 1984.
4. Shalkhauser, K.A., "Test Results for 20-GHz GaAs FET Spacecraft Power Amplifier," NASA TM-87072, 1985.
5. Sanders, A., "20 x 20 High Speed Microwave Matrix Switches," NASA TM-83775, 1984.

TABLE I. - COMPONENTS DEVELOPED TO POC UNDER NASA
TECHNOLOGY DEVELOPMENT PROGRAM

Technology	Contractors
Low noise 30 GHz receiver	LNR, ITT
IF Switch matrix	Ford Aerospace, GE
20 GHz Impatt transmitter	LNR, TRW
20 GHz GaAs FET transmitter	TRW, TI
20 GHz multimode TWT	Hughes
Power processor for multimode TWT	TRW
Baseband processor	Motorola
30 GHz Solid state transmitter	TRW
Low cost ground terminal antennas	Scientific Atlanta

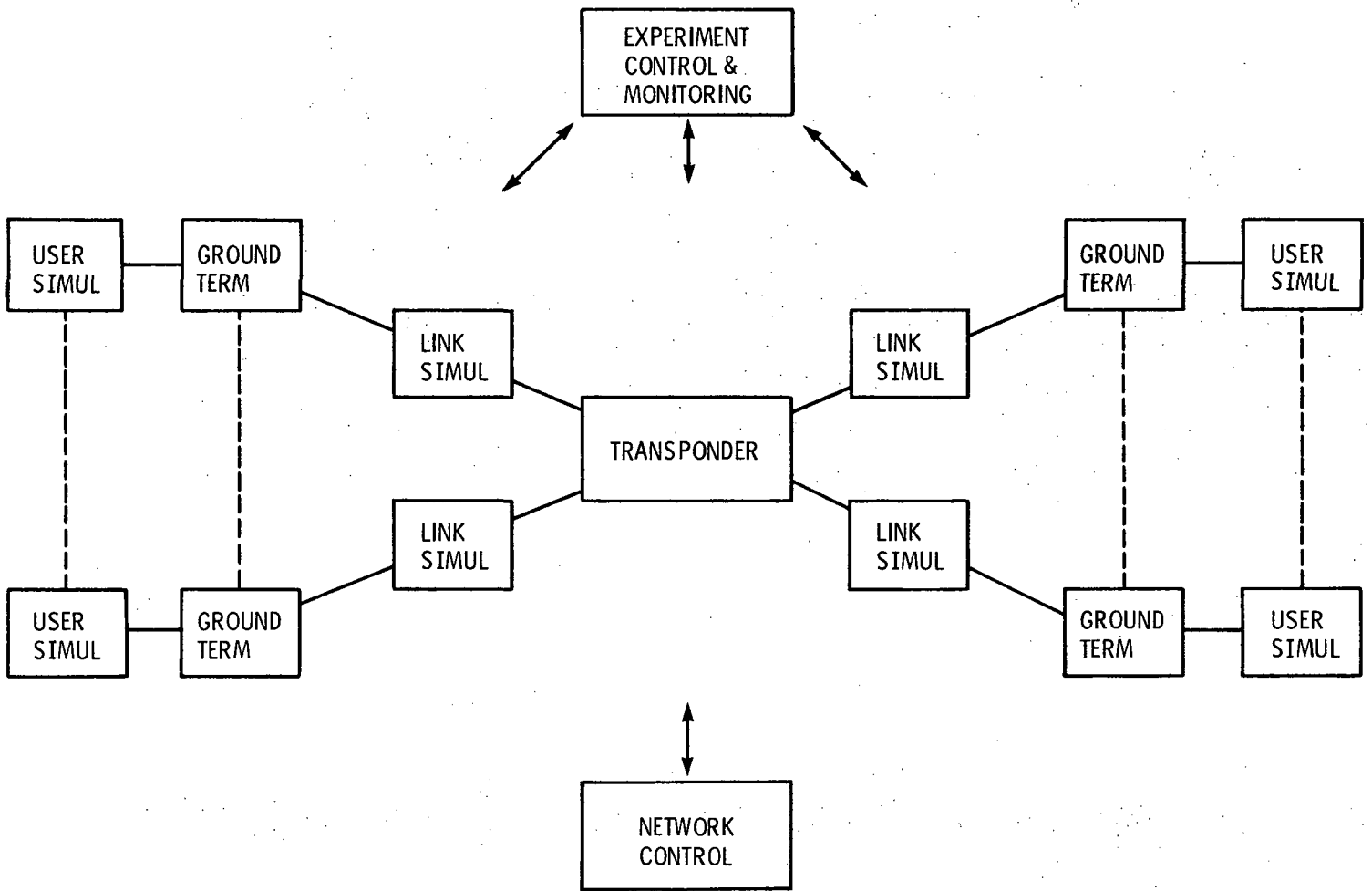

Figure 1. - Hardware simulation of communication network.

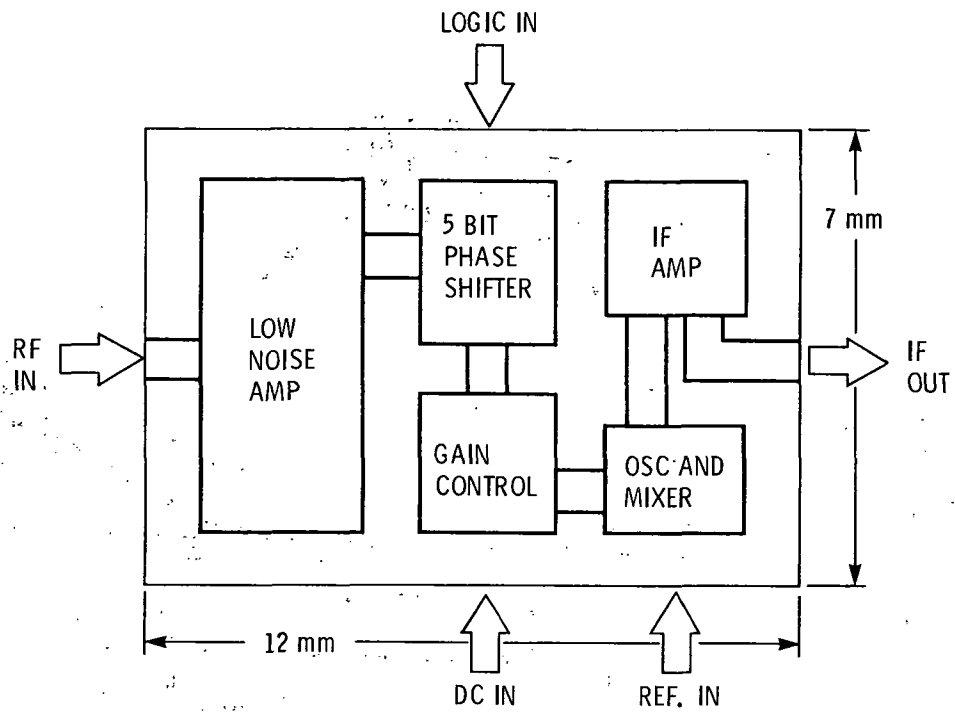

Figure 2. - 30 GHz Monolithic receive module.

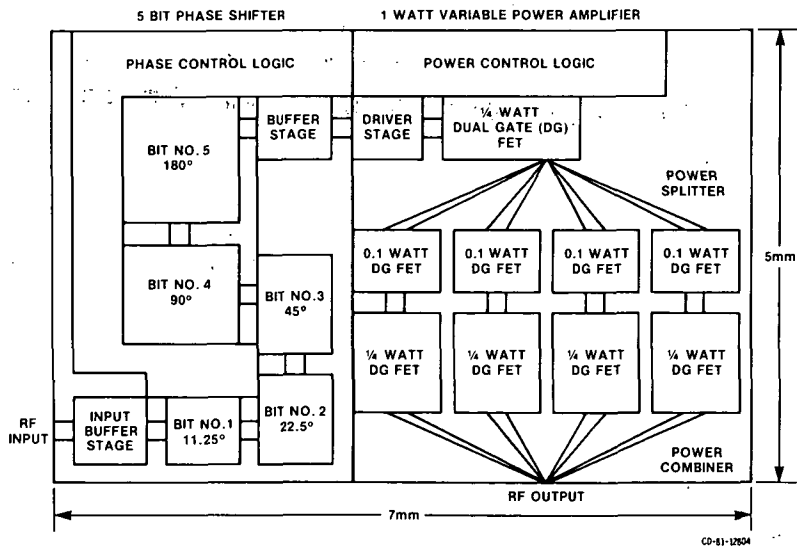

Figure 3. - 20 GHz GaAs Monolithic transmit module.

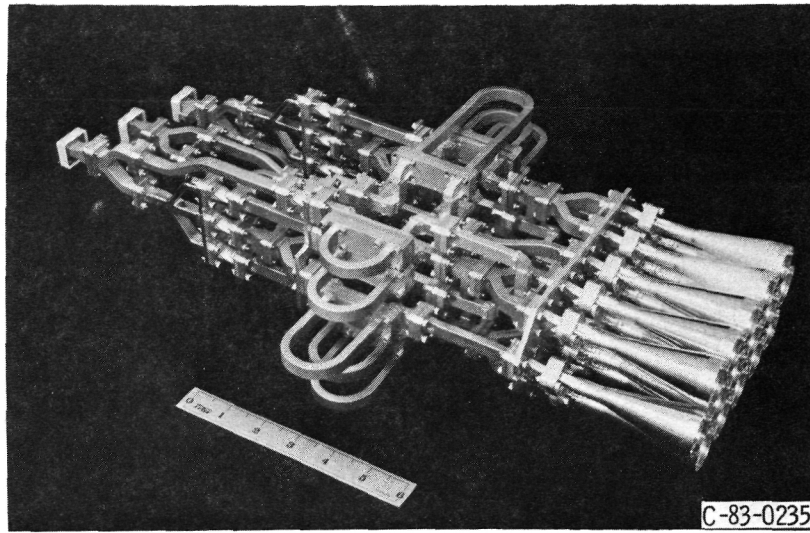

Figure 4. - 30 GHz, 3 beam horn cluster.

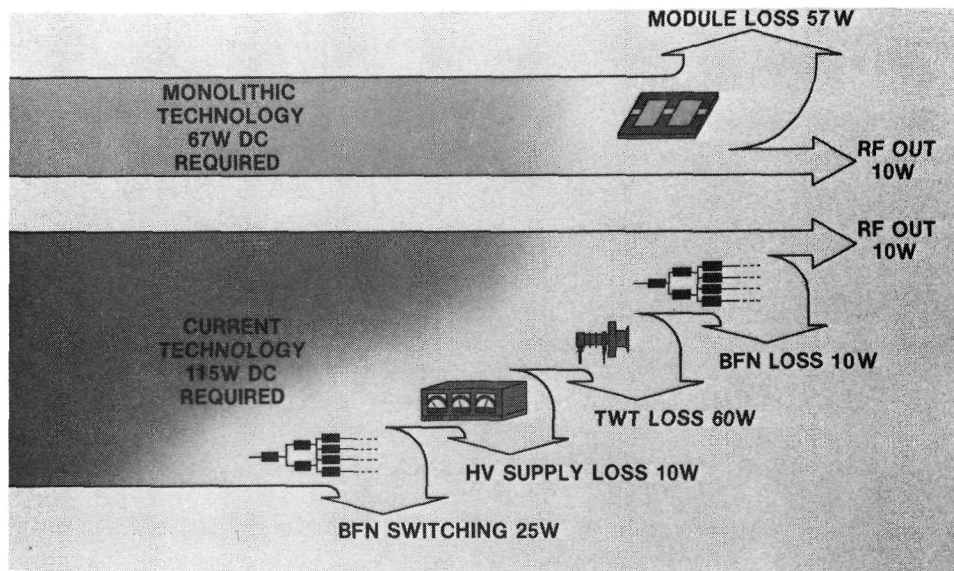
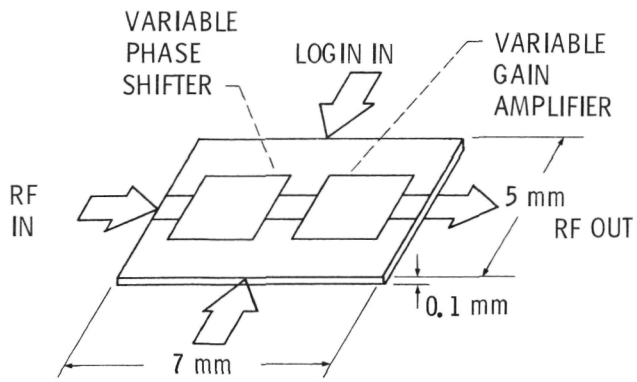

Figure 5. - Comparison of technologies used to produce directed RF power radiation.

20 GHz MONOLITHIC TRANSMIT MODULE



SCANNING SPOT BEAM MMIC FEED SYSTEM

SPACE-FED ACTIVE (LENS) ARRAY

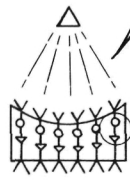

MULTIPLE SCANNING BEAM FEED

PARABOLIC MAIN REFLECTOR

PARABOLIC SUBREFLECTOR

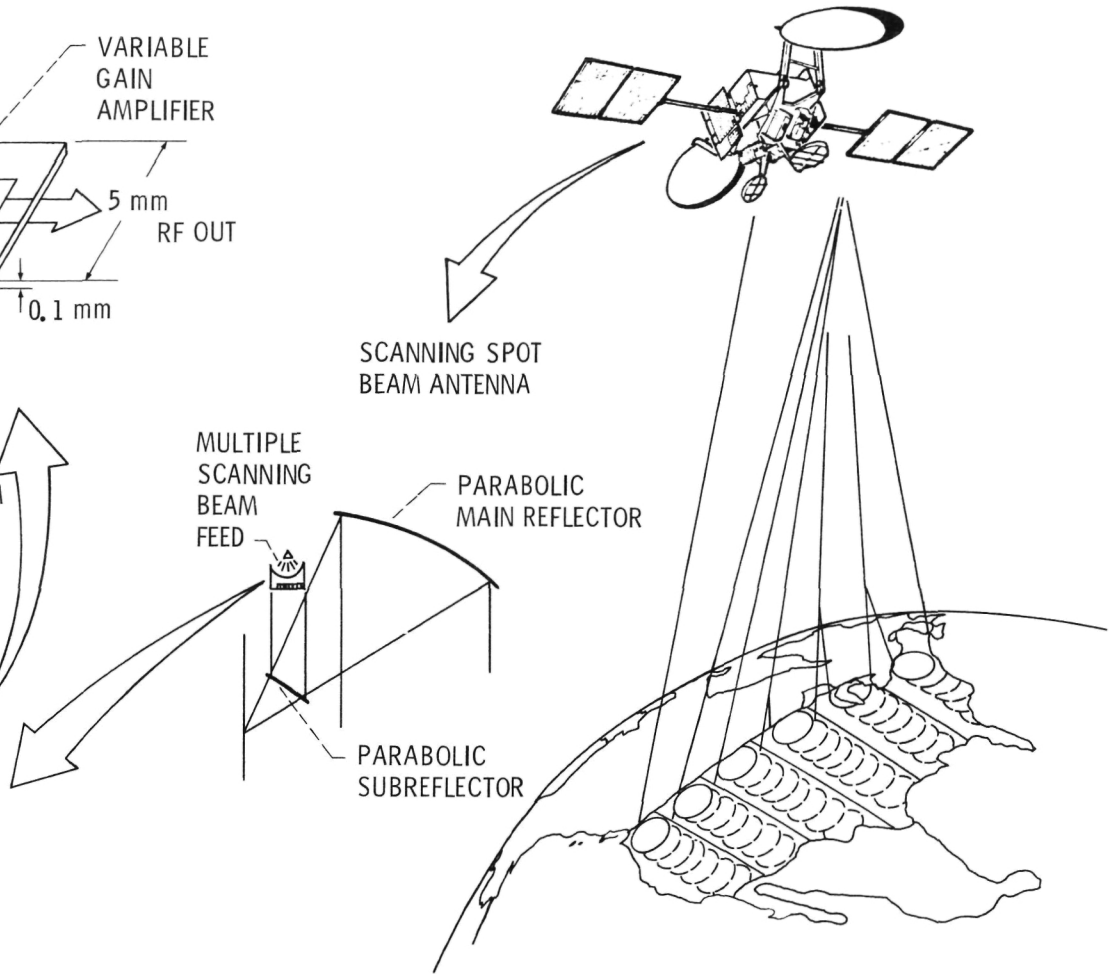

Figure 6. - Multiple Scanning Spot Beam antenna concept.

ORIGINAL PAGE IS
OF POOR QUALITY

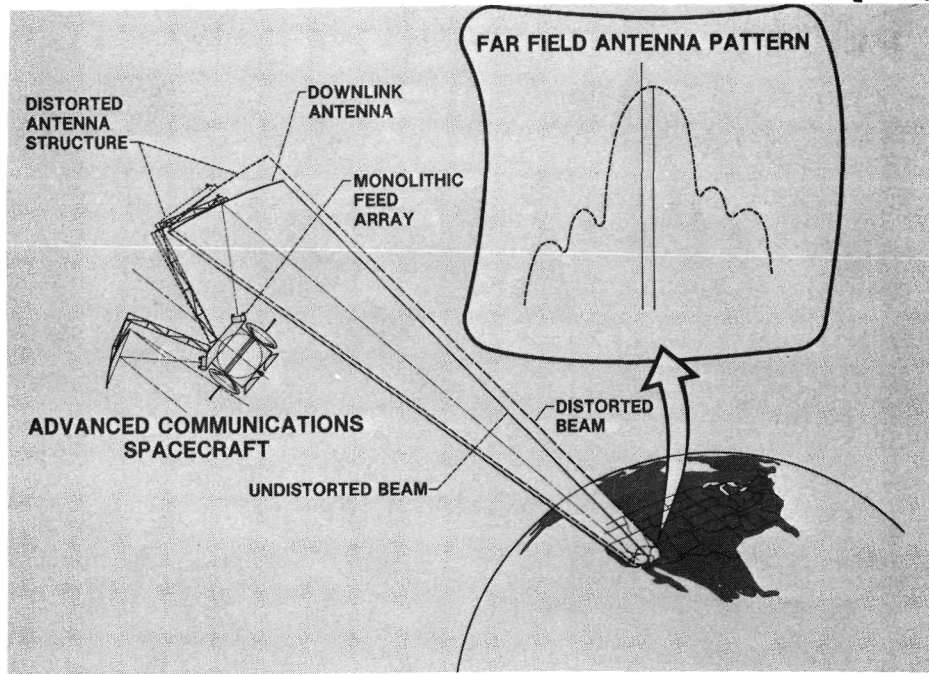
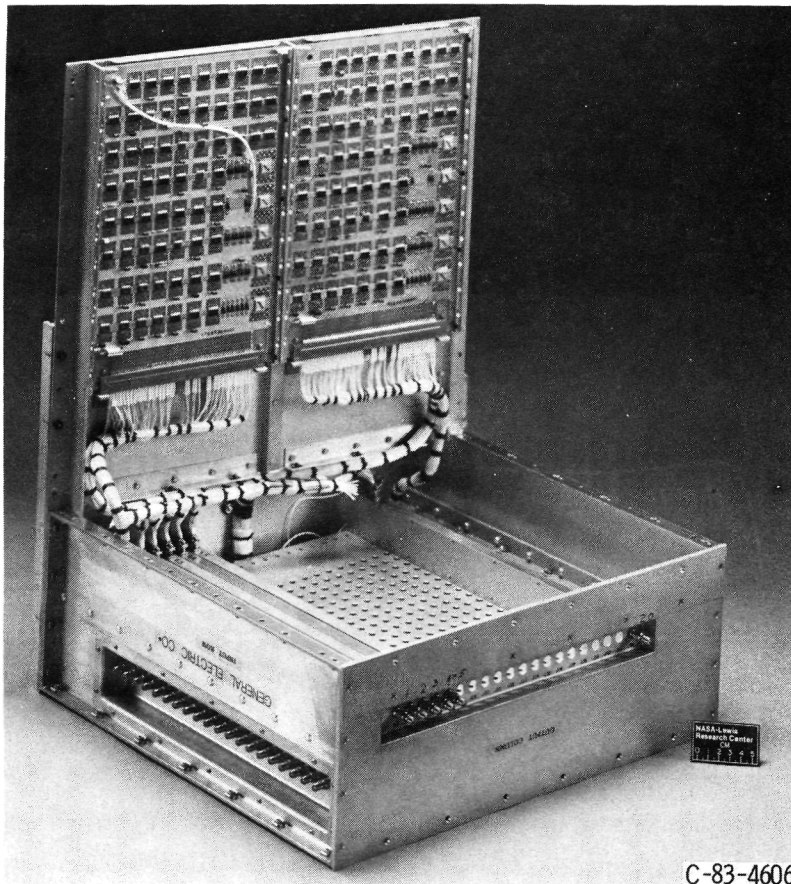

Figure 7. - Effects of reflection distortion on an antenna beam.



C-83-4606

Figure 8. - Proof-of-concept 20x20 matrix switch.

1. Report No. NASA TM-87201	2. Government Accession No.	3. Recipient's Catalog No.	
4. Title and Subtitle Technology Achievements and Projections for Communication Satellites of the Future		5. Report Date	
		6. Performing Organization Code 650-60-20	
7. Author(s) James W. Bagwell		8. Performing Organization Report No. E-2856	
		10. Work Unit No.	
9. Performing Organization Name and Address National Aeronautics and Space Administration Lewis Research Center Cleveland, Ohio 44135		11. Contract or Grant No.	
		13. Type of Report and Period Covered Technical Memorandum	
12. Sponsoring Agency Name and Address National Aeronautics and Space Administration Washington, D.C. 20546		14. Sponsoring Agency Code	
15. Supplementary Notes Prepared for the 11th Communications Satellite Systems Conference, sponsored by the American Institute of Aeronautics and Astronautics, San Diego, California, March 16-20, 1986.			
16. Abstract Over the past five years, NASA has conducted an extensive program to advance the state-of-the-art in communication satellite technology. NASA is preparing to conduct a flight experiment in 1989 to verify the performance of this technology. Shortly thereafter, we should see the communications satellite industry begin to use this technology and enter into a new era of satellite communications includ- ing services in a new communications band, 30/20 GHz. What new capabilities and services does this NASA developed technology enable? What does the future hold for even better systems and services and what technology barriers must be over- come to enable these to happen? This paper addresses these questions by des- cribing the accomplishments of the NASA sponsored technology program over the past five years and projecting possible technology advancements over the next 10 yr. A systems scenario for the year 2000 using this technology is described. The projected capabilities and systems described herein are based on technology advancements alone, without consideration for competing terrestrial technologies or market demand. These and other factors may affect the rate of development and characteristics of future satellite communications systems.			
17. Key Words (Suggested by Author(s)) Antennas; Onboard processing; Transmitters; Receivers		18. Distribution Statement Unclassified - unlimited STAR Category 32	
19. Security Classif. (of this report) Unclassified	20. Security Classif. (of this page) Unclassified	21. No. of pages	22. Price*

National Aeronautics and
Space Administration

Lewis Research Center
Cleveland, Ohio 44135

Official Business
Penalty for Private Use \$300

SECOND CLASS MAIL

ADDRESS CORRECTION REQUESTED



Postage and Fees Paid
National Aeronautics and
Space Administration
NASA-451

NASA
