

N86-19725**THE STATUS OF SILICON RIBBON GROWTH TECHNOLOGY
FOR HIGH-EFFICIENCY SILICON SOLAR CELLS****T.F. Ciszek****Solar Energy Research Institute
Golden, CO 80401**

More than a dozen methods have been applied to the growth of silicon ribbons, beginning as early as 1963. The ribbon geometry has been particularly intriguing for photovoltaic applications, because it might provide large area, damage free, nearly continuous substrates without the material loss or cost of ingot wafering. In general, the efficiency of silicon ribbon solar cells has been lower than that of ingot cells. This presentation reviews the status of some ribbon growth techniques that have achieved laboratory efficiencies greater than 13.5% -- edge-defined, film-fed growth (EFG), edge-supported pulling (ESP), ribbon against a drop (RAD), and dendritic web growth (web).

Conventional silicon ingot technology converts polycrystalline silicon having a market price around \$80/kg into polished wafers that sell for about \$1300/kg, through cylindrical crystal growth, wafering, and polishing steps. Silicon ribbon growth, starting with the same material, uses one step to achieve damage-free, planar-surface substrates. The accompanying figures detail maximum pulling velocities and surface area generation rates for sheets and ingots, using a simple one-dimensional model. Experimentally, the velocities achieved are 20% to 40% of the calculated ones. Graphical surface area generation rate results from the model are presented both for the case of no rate limitations due to wafering of ingots, and also for the case of combined growth and various wafering technologies. When assessing the relative merits of sheet and ingot growth, in addition to comparing surface area generation rates, one must also remember that ingot technology uses about 100% more raw material and incurs additional wafering and polishing costs.

Schematic diagrams of the four ribbon growth methods discussed in detail in the presentation are shown in the figures. All have achieved lab scale cell efficiencies over 13.5% at AM1, and in fact one method has yielded large-area modules (4675 cm²) with >13% efficiency. A comparison of the characteristics of the four methods is given in the two tables. It can be seen that no single method possesses all of the attributes one desires in a PV sheet material. Perhaps the ideal sheet growth method is yet to be invented.

PRECEDING PAGE BLANK NOT FILMED

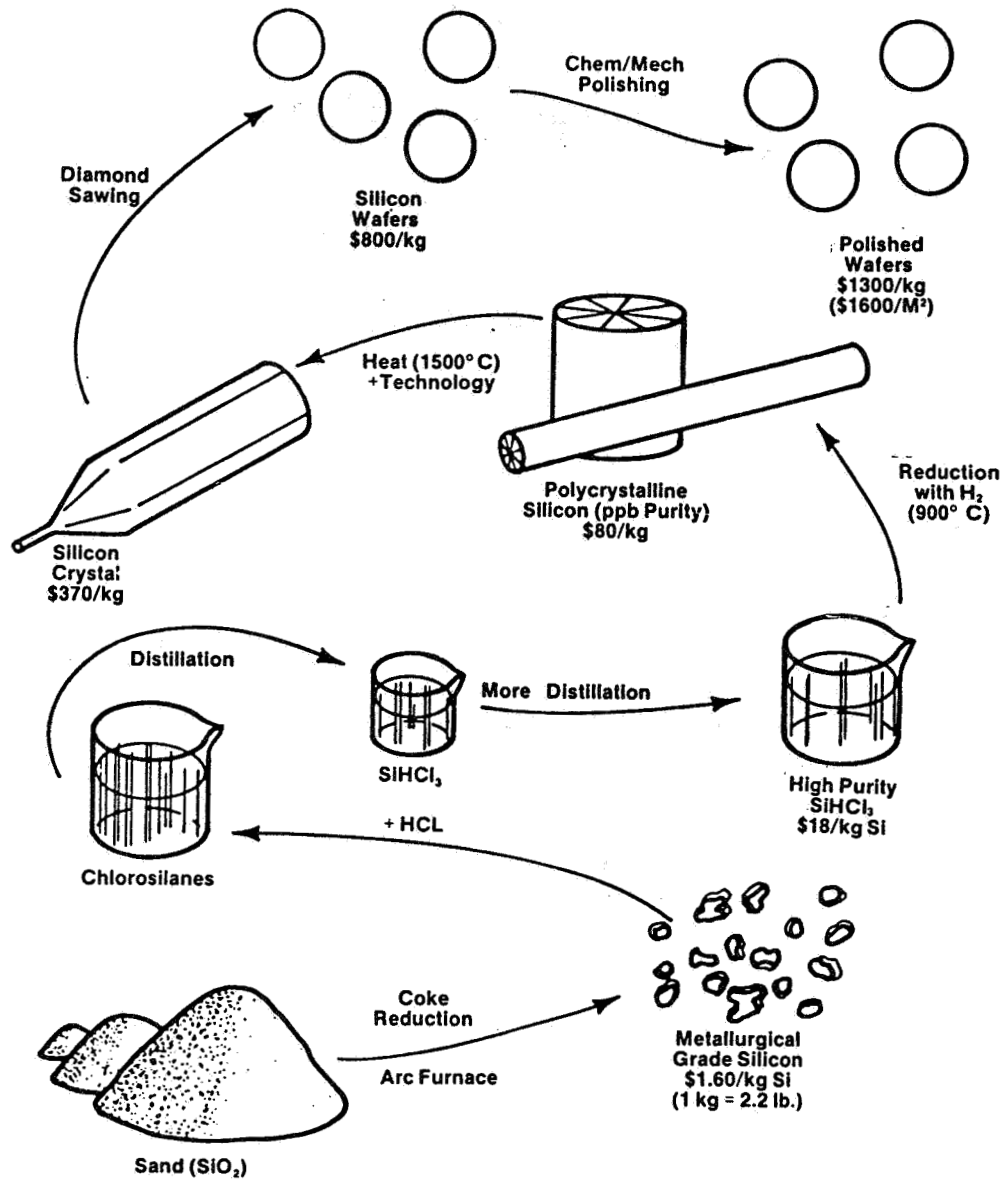

PRECEDING PAGE BLANK NOT FILMED

For Ribbon Crystals

$$V_{max} = \frac{1}{L\rho_m} \left[\frac{\sigma\epsilon(W+t)K_m T_m^5}{Wt} \right]^{1/2}$$

FOR CYLINDRICAL CRYSTALS:

$$V_{max} = \frac{1}{L\rho_m} \left[\frac{\sigma\epsilon K_m T_m^5}{r} \right]^{1/2}$$

WHERE

- T_m = MELTING TEM.²
- K_m = THERMAL COND. AT T_m
- ρ_m = CRYSTAL DENSITY AT T_m
- σ = STEFAN-BOLTZMANN CONST.
- ϵ = EMISSIVITY
- W = RIBBON WIDTH
- t = RIBBON THICKNESS
- r = CRYSTAL RADIUS

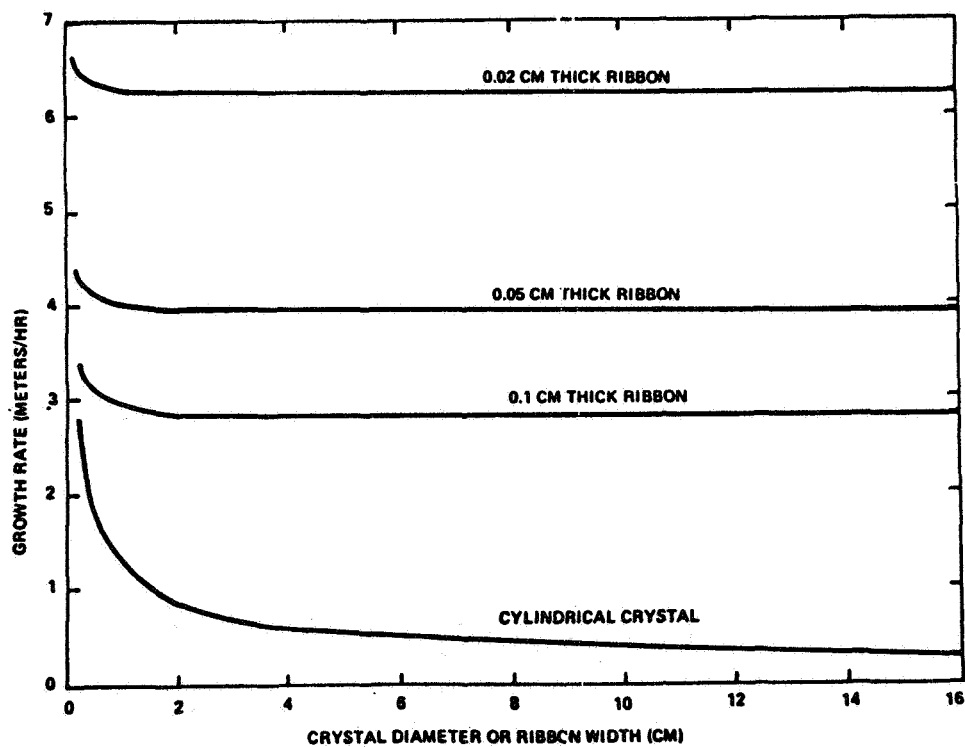

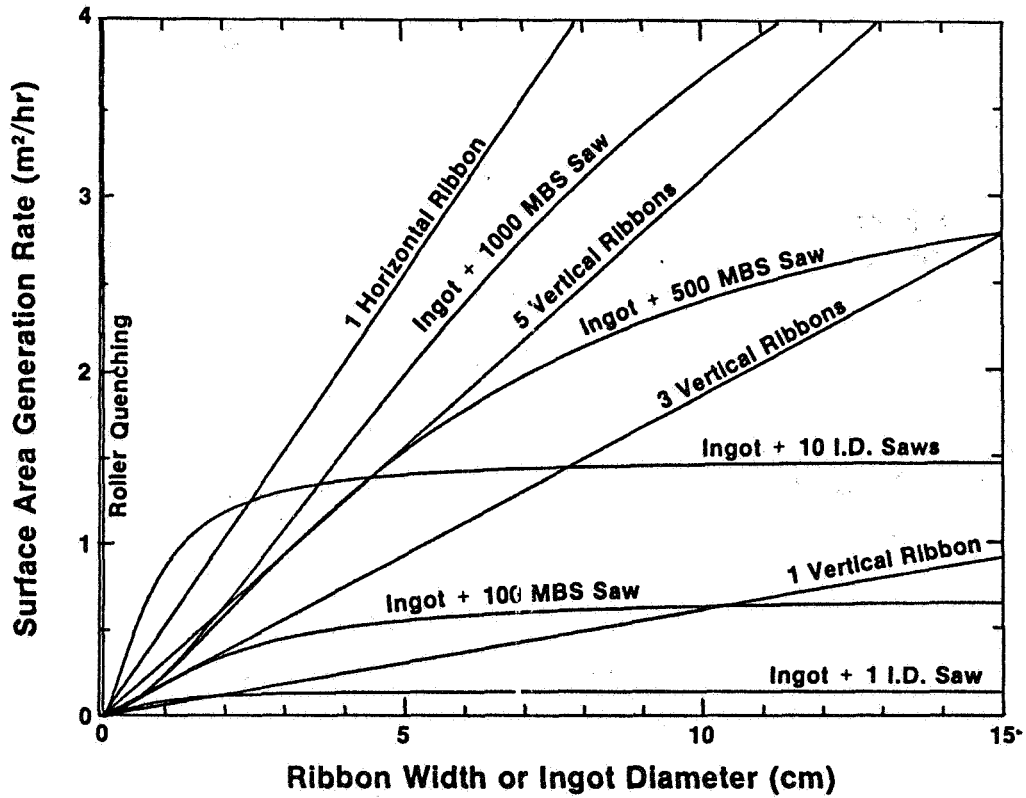
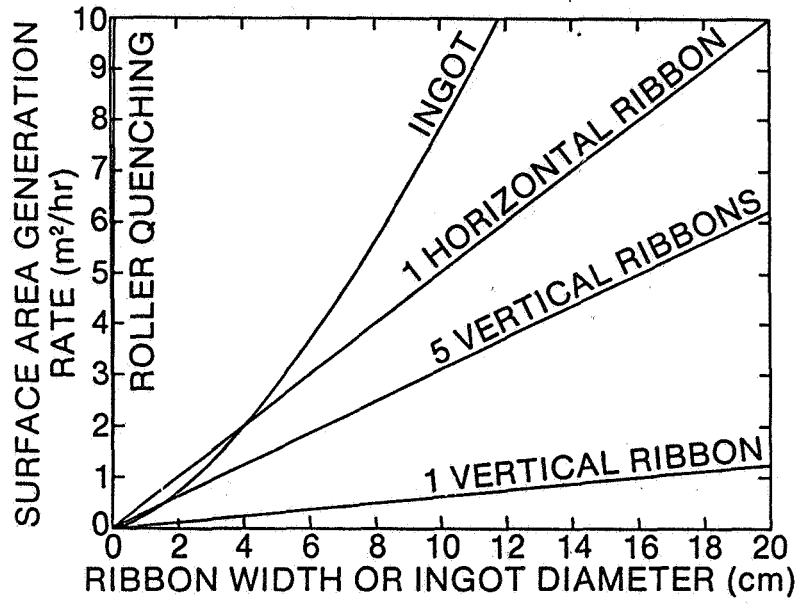

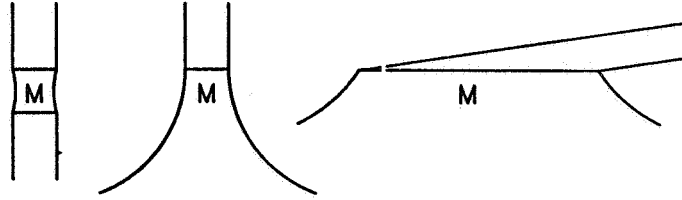

- DENDRITIC WEB (WEB,1963)
- STEPANOV (S,1967)
- EDGE-DEFINED, FILM-FED GROWTH (EFG,1972)
- HORIZONTAL RIBBON GROWTH (HRG,1975/ LASS,1980)
- RIBBON-AGAINST-DROP (RAD,1976)
- RIBBON-TO-RIBBON ZONING (RTR,1976)
- SILICON-ON-CERAMIC (SOC,1976)
- CAPILLARY ACTION SHAPING TECHNIQUE (CAST,1977)
- CONTIGUOUS CAPILLARY COATING (CCC,1977/ S-WEB,1982)
- INVERTED STEPANOV (IS,1977)
- ROLLER QUENCHING (RQ,1979)
- EDGE-SUPPORTED PULLING (ESP,1980)
- INTERFACE-CONTROLLED CRYSTALLIZATION (ICC,1981)

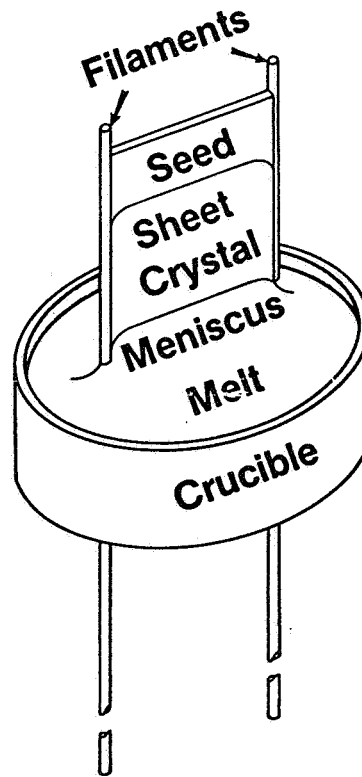
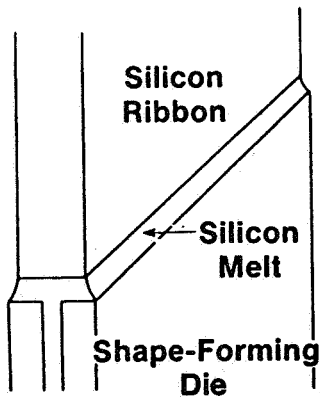

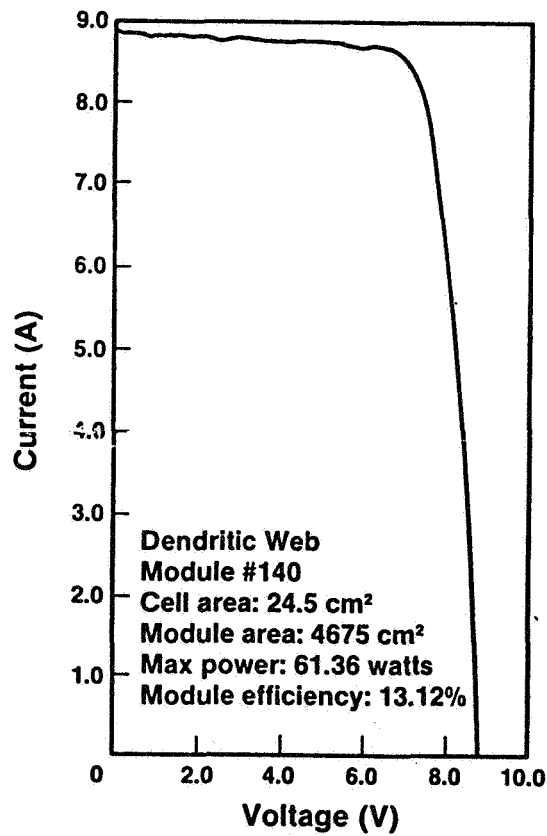
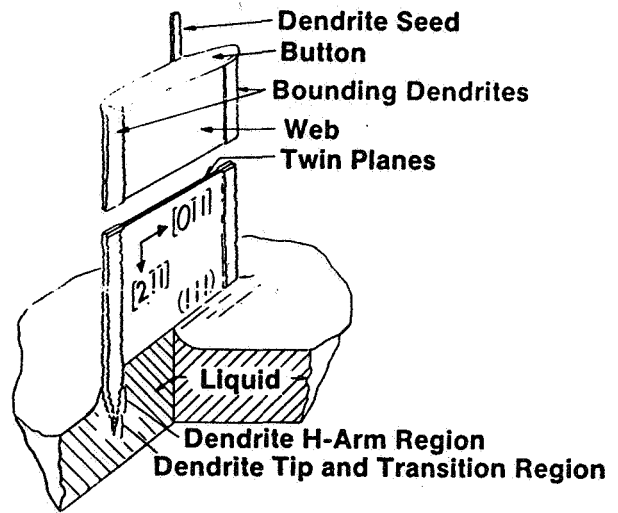
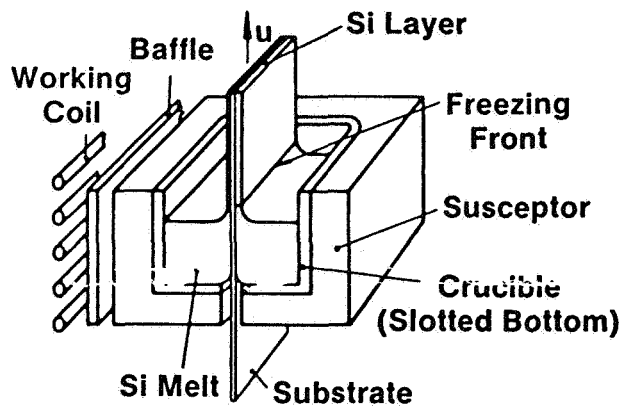

Stability and Purity

	EFG	ESP	RAD	WEB
MENISCUS HEIGHT (mm)	~0.5	~6	~6	~6
THERMAL CONTROL (°C)	~1	1-10	1-10	0.1-1
SURFACE MORPHOLOGY	RIPPLED, STRIATED	SMOOTH, BOWING	FLAT (2um)	VERY SMOOTH
IMPURITY SOURCES	DIE, CRUCIBLE	FILAMENTS	CARBON RIBBON	HOT ZONE PARTS
IMPURITY SEGREGATION	$k_0 \sim 1$	$k_0 < k_1 < 1$	$k_0 < 1$	$k_0 < k_1 < 1$
USE OF IMPURE SILICON	NO	YES	YES	WITH RESTRICTIONS
AREAS OF CONCERN	IMPURITIES, STRESSES	BOWING, STRESSES	IMPURITIES, STRUCTURE	WIDTH, STRESSES

Growth Characteristics

	EFG	ESP	RAD	WEB
GROWTH RATE (cm/min)	2	2	10	2
MAXIMUM WIDTH (cm)	45	10	10	6
TYP. THICKNESS (microns)	200	200	80	160
MAXIMUM LENGTH (meters)	30	~1	30	11
CRYSTAL STRUCTURE	TWINS, GB'S SIC INCLUS	LARGE GRAINS	NARROW GRAINS	SINGLE (111)TWIN
SOLAR CELL EFFICIENCY (%)	14 (12)	14 (12)	13.5(11)	16 (13)
TECHNOLOGY/ SKILL	HIGH	LOW	LOW	HIGH

Criteria for the “Ideal” Sheet Growth Method

- **Good Crystal Perfection**
- **Flat Smooth Surface**
- **High Purity**
- **Easy Control**
- **High Throughput**

DISCUSSION

- KALEJS: Regarding your comment on the tolerance for impurities, there are really two issues that have to be distinguished. To control the interface, there is really only one parameter that counts, which is the interface gradient. All these methods have about the same tolerance when it comes to the stability with respect to perturbations due to constitutional supercooling. The tolerance you are referring to was basically the tolerance in the actual amount of impurities segregated where certainly EFG, with K_{eff} equal to unity, is at a disadvantage. When you start using metallurgical grades of silicon, it is only the interface gradient that determines the constitutional supercooling that counts. It has been shown in 1980 in web, for example, that 10^{18} impurities start a significant breakdown of the web dendritic structure. We find that in EFG at about 10^{18} , we have about the same effects. You start losing efficiency, not perhaps because of point-defect impurity problems but because of structural breakdown. Again, this is only a function of the gradient.
- CISZEK: For the purpose of this symposium, which is on high-efficiency cells, that point is moot anyway. No one would want to use very impure poly to try to achieve high-efficiency cells. It would become more of a concern if you were trying to make low-cost cells using a lower-cost feedstock at the sacrifice of efficiency.
- CORBETT: Can you tell us any more about your comment about the molybdenum and iron?
- CISZEK: It's borrowed work from researchers at Mobil. I believe the experiment was done by progressively increasing the amounts of the electrically active dopant to bring the resistivity levels down in the melt during the growth of a single ribbon. When the resistivity was down to about 0.2 Ω -cm then a small amount of molybdenum was added, and then a short time after that a small amount of iron was added, and then the cells were made. It must imply interaction between point defects and non-metallic impurities with these metallic impurities. It's a region of very active research interest now, to try to understand these effects better.
- CORBETT: Would you care to speculate on how much improvement continued effort in ribbons might yield?
- CISZEK: There is certainly going to be some, and my own personal feeling is that there probably is a ribbon growth method that hasn't even been discovered yet that would have a lot better properties. It should be, in principle, possible to grow a ribbon that is truly single-crystal without twin planes or dislocations. It should have at least as good and probably better properties than the ingots, because of the close proximity of the surface to any point defects within the material during the cooldown cycles, and hence there is

the possibility of eliminating these to the surface, by vacancy climbing or even interstitial moving during the cooldown cycle. This ideal technique has not yet been discovered. With the techniques we have to work with, we make the assumption that we are going to live with coherent twins as a minimum in the material, and we are going to live with oxygen and possibly some carbon in the material, and then we ask how can we passivate or getter the material to get the best results. In that kind of approach you are never really going to get quite as good as ingot material, although you should be able to get to a value perhaps 95% as good as ingot material.

STORTI: Do we have very good numbers on what in fact are the minority carrier diffusion lengths of these different ribbon technologies for the given doping? And do we have an idea as to how much those particular things can be improved or what those particular values are at the moment?

CISZEK: We don't have anything like a round-robin where a particular technique has been applied to measuring the diffusion length in all the materials. I know that there is some variety in the approaches that are used. For example, Belouet and his coworkers working on the ribbon-against-drop method use an electrolytic sort of contact to measure diffusion length in the material. Westinghouse uses the surface photovoltage (SPV) technique and photoconductive decay, and Mobil uses SPV.

STORTI: The reason I bring up the question is that it is possible to process devices in such a way that you can get efficiencies that look quite good, even though the diffusion length is not tremendously high.

CISZEK: We don't have a standardized method that's been used to systematically compare the different growth methods and tell what their diffusion lengths are. Recently there have been some intriguing things noticed about diffusion length or lifetime as a function of cooling rate of some of the ribbon techniques. People are discovering that because the ribbons cool so quickly, there is some sort of a quenching problem that is lowering the lifetime, but this can be recovered by a subsequent heat treatment (around 1000° or higher for some length of time) followed by a slow cooling, which can bring the lifetimes back up.

LESK: What number of slices per inch did you use for your cutting efficiency?

CISZEK: I used 2,000 per meter for ID sawing and 2,500 per meter for multiblade wafer sawing.

KIM: In your calculations, you assumed a relatively simple radiational heat loss. If you included a back radiation from the thermal environment that could decrease your maximum growth rate significantly.

CISZEK: Definitely. The values here are high. I look at them as upper limits, that you are not going to exceed. They are a goal you can

work toward. The calculated values are all too high and, interestingly enough, they are high in a way that real rates are 20% to 40% as high as the calculated rates both for the ingots and for the ribbon. In the case of ingots, the 40% numbers would come from float-zone-type growth and the 20% numbers would come from Czochralski-type growth. The ribbons stay around 20% to 30% of maximum values because if they try to go faster, thermal stresses and buckling and things like that become significant problems.

RAO: Have you grown material from quartz crucibles and from graphite crucibles, and do you see similar kinds of effects between ESP and EFG materials?

CISZEK: We have done all of our ESP work using quartz crucibles. We did use a number of different filament materials including quartz and some graphite filaments. Arthur D. Little Corp. uses graphite crucibles in the technique. I don't think a whole study has been pulled together to compare influences of the different impurities -- even within ESP, let alone comparing ESP to EFG. In principle it could be done, but it has not been done.