

N86-19936

Optimization of Controlled Environments for Hydroponic
Production of leaf Lettuce for Human Life Support in CELSS

Cary A. Mitchell, Sharon L. Knight, and Tameria L. Ford
Department of Horticulture
Purdue University
West Lafayette, IN 47907

Every scheme of mass recycling within a CELSS features some photosynthetic organism as a figure of central importance in the overall process (Fig. 1). Air revitalization (i.e., CO₂ scavenging and O₂ regeneration) as well as water purification, mineral recycling, and generation of edible biomass all ultimately are driven by the photosynthetic process. Our research project in the food production group of the CELSS program seeks to define optimum conditions for photosynthetic productivity of a higher plant food crop.

Because of our interest in photosynthesis per se, we have elected to work with a salad crop, whose major edible product is new photosynthetic tissue. Under optimum conditions, such a system becomes increasingly productive during the growth cycle. Leaf lettuce is a salad crop for which commercial hydroponic production in controlled environments already is a reality. The cultivars we work with have a harvest index of at least 80% edible biomass, and even though the main photosynthetic product is cellulose, food scientists feel that advances in food

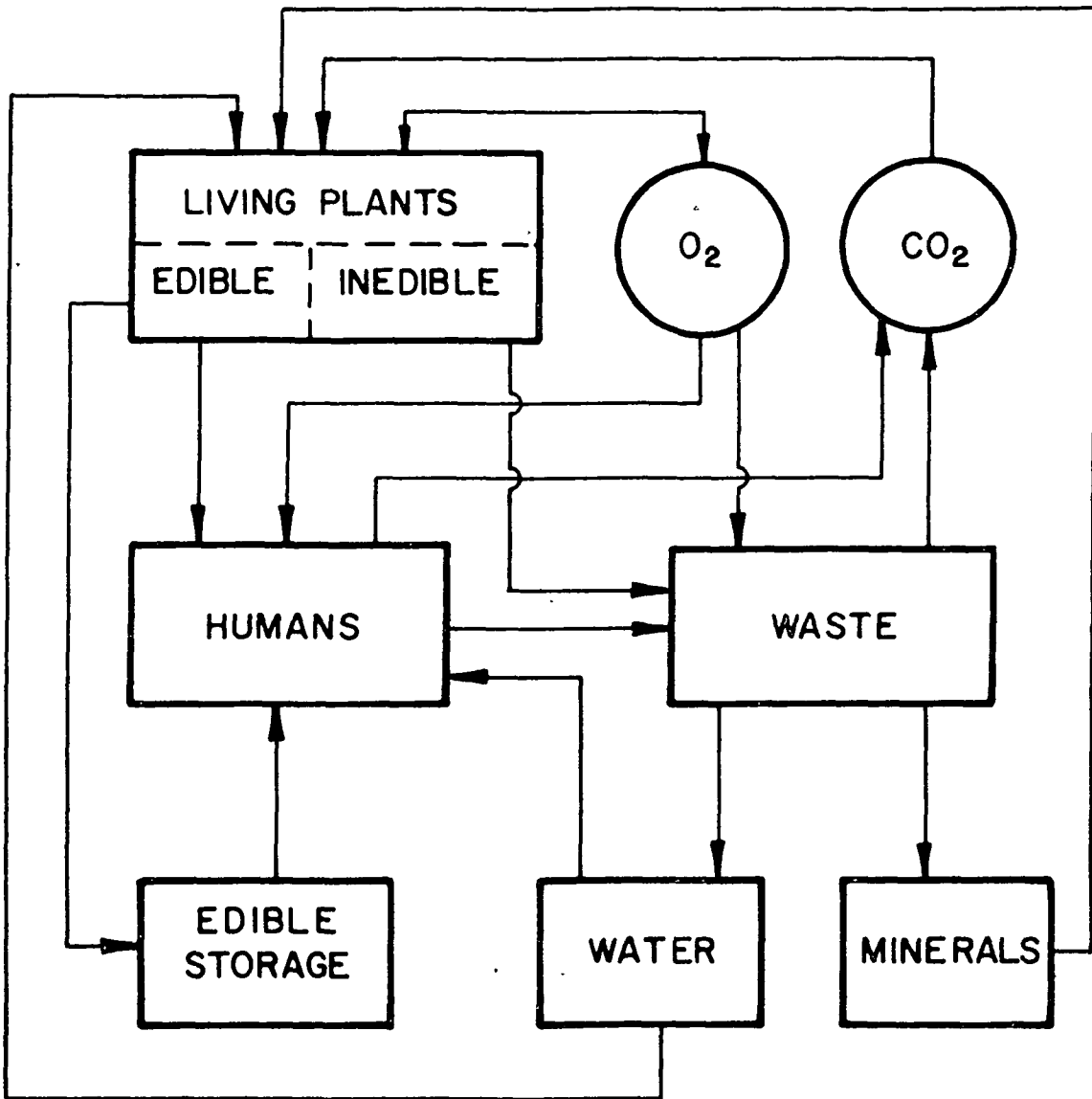

Figure 1. Schematic depiction of a CELSS including photoautotrophic and heterotrophic components, food generation, water purification, air revitalization, and mineral waste recycling.

processing technology will take care of digestibility or palatability limitations of candidate species. Leafy vegetables also provide vitamins and minerals needed for a balanced vegetarian diet that are not provided by protein or calorie crops, and food scientists further tell us that salad crops need not always be consumed fresh, but can be dried, flaked, processed, and incorporated into food bars in appropriate proportions. Leaf lettuce also tends to be quite tolerant of NH_4^+ in nutrient solutions, which may be very useful for recycling nitrogenous human wastes in CELSS. In fact, high nitrogen levels in nutrient solution, including NH_4^+ , contribute substantially to the enhanced growth of some lettuce cultivars in response to elevated output from fluorescent (FL) + incandescent (IC) lamps.

Positive growth responses to elevated light and nitrogen prompted us to further test lettuce growth responses to high light from lamp types more energy efficient and longer-lived than fluorescent lamps. A walk-in growth room equipped with water-cooled, high pressure sodium (HPS) vapor, metal halide (MH), and quartz iodide (QI) lamps provided $1100 \mu\text{mol s}^{-1} \text{m}^{-2}$ of photosynthetically-active radiation (PAR), which is roughly half full sunlight level. A recirculating nutrient film system with separate root temperature control also has been installed within the chamber. The use of HPS radiation to grow lettuce is paradoxical: lettuce seems to grow well with HPS as a sole

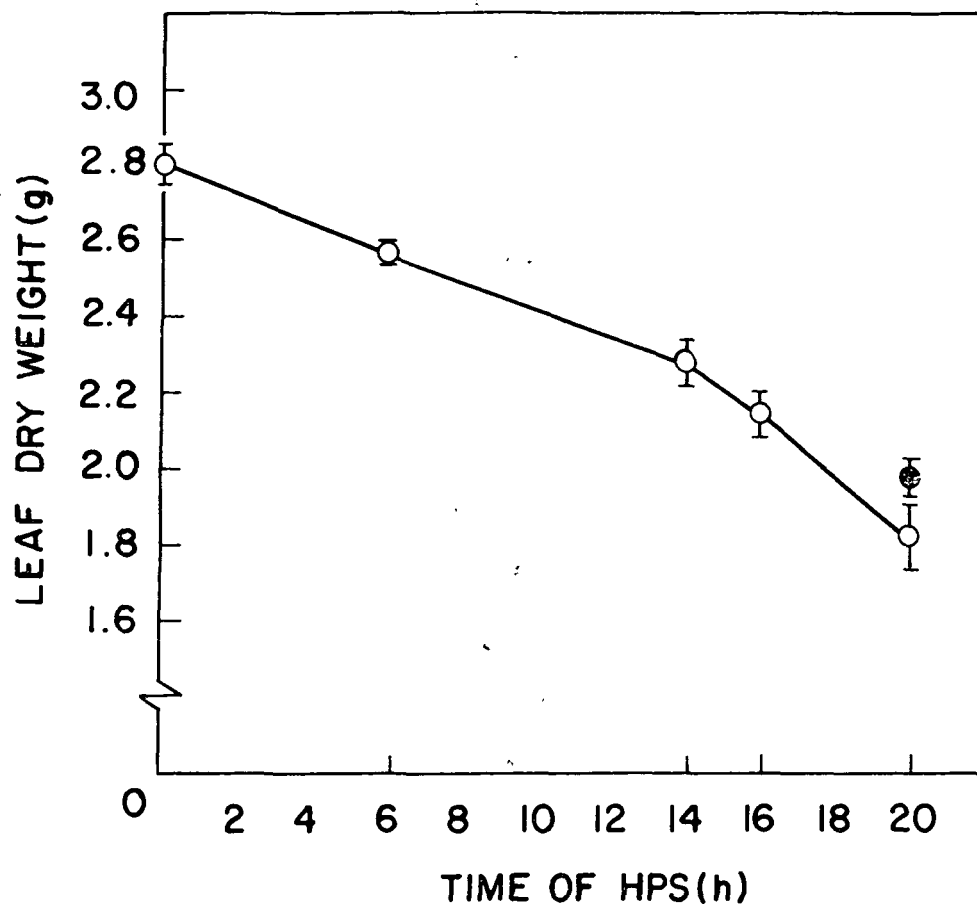

Figure 2. Effect of different times of exposure to high irradiance HPS radiation on leaf dry weight per plant of 'Black-Seeded Simpson' lettuce after 19 days of growth. All treatments indicated by open circles received 20 h day⁻¹ of metal halide + quartz iodide radiation at 300 $\mu\text{mol s}^{-1} \text{m}^{-2}$ of PAR. When all 3 sources were energized, PPFD was 1100 $\mu\text{mol s}^{-1} \text{m}^{-2}$. The closed symbol represents plant response to 20 h day⁻¹ of FL + IC lighting at 750 $\mu\text{mol s}^{-1} \text{m}^{-2}$.

radiation source if irradiance level is kept low, but its response to high irradiance HPS, particularly in combination with other sources, is less clear. Therefore, we are investigating effects of different dosages of HPS in combination with a constant dosage of MH + QI. Nineteen-day-old 'Black-Seeded Simpson' lettuce plants grown for 20 h day⁻¹ under HPS + MH + QI become abnormally yellow under this high radiation regime. Doubling the N level and providing N as a mixture of NH₄⁺ + NO₃⁻ instead of just as NO₃⁻ increased plant size and resulted in slightly less yellowing of inner leaves. If MH + QI were maintained at 20 h day⁻¹, but the HPS reduced to 14 h day⁻¹, the plants become even less yellow, and a little larger than at 20 h HPS. We have extended this reduction in exposure to high irradiance HPS to zero while keeping MH + QI constant, and preliminary evidence suggests that leaf dry weight increases as duration of HPS radiation decreases (Fig. 2). The highest yield obtained has been with MH + QI alone at only 300 μmol s⁻¹ m⁻². This is substantially greater than the leaf weight of plants grown in a similar culture system under 20 h day⁻¹ at 750 μmol s⁻¹ m⁻² of FL + IC lighting. The input wattage of IC in the latter regime was only 8%, whereas that in combination with MH was 31%. That may be a key factor in the greater yield at the lower photosynthetic photon flux density (PPFD) than at the higher PPFD. Nevertheless, none of these are particularly high

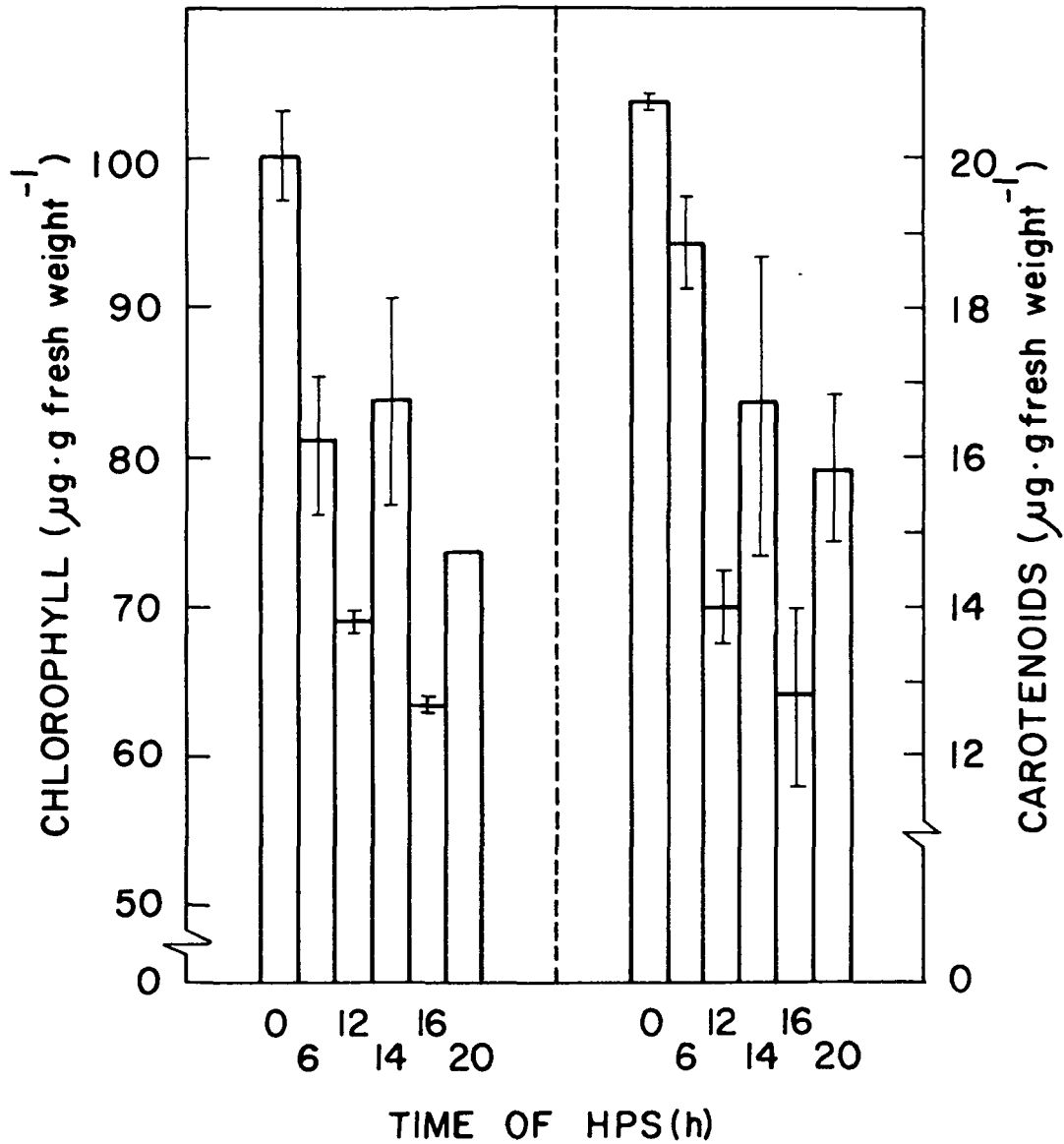

Figure 3. Effect of different times of exposure to high irradiance HPS radiation on specific chlorophyll and specific carotenoid contents of outer leaves from 18-day-old 'Black-Seeded Simpson' lettuce plants.

yields for 19-day-old plants, but they do suggest that high irradiance HPS damages leaf lettuce.

The leaf yellowing caused by excessive HPS radiation may be due either to an increase in yellow pigments or to a decrease in green pigments. Preliminary evidence suggests that specific carotenoid content actually decreases with increasing HPS dosage, as does specific chlorophyll content (Fig. 3), so the HPS effect is a true chlorosis, preventable mainly by avoiding use of HPS lamps, and to a lesser extent by using double-strength N as NH_4^+ + NO_3^- . We plan to test effects of low intensity HPS or MH as sole radiation sources on yield and pigment content of leaves. We also are equipping our walk-in chambers with a CO_2 control capability, and feel that defining the proper combinations of high CO_2 , long photoperiod, moderate output from the right lamp types, and proper timing of those treatments is needed to consistently obtain superior lettuce yield rates.

We already have demonstrated the feasibility of this approach on a smaller scale, using a second-generation Minitron chamber system developed in our laboratory (Fig. 4). Each cylindrical chamber is 24 inches in diameter, has a 24-inch-high growth height, and transmits radiation from external lamps. A fan in the base of the chamber pulls air down through the center

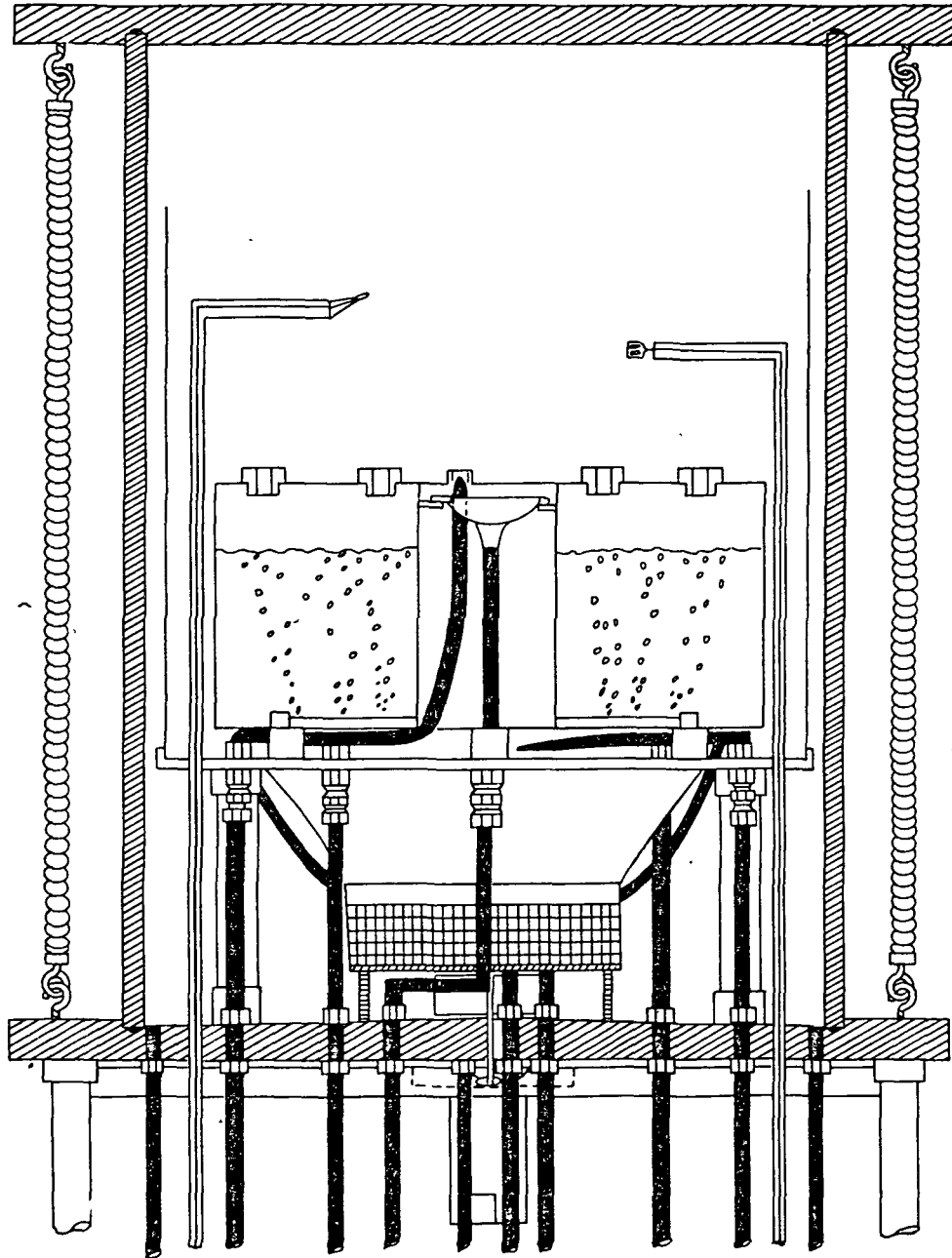

Figure 4. Schematic side view of a Minitron II plant growth chamber for hydroponic growth of plants in a controlled environment, including a flowing, defined atmosphere.

of a donut-shaped hydroponics pot, through the fins of a heat exchanger, outward and upward between the outer wall and a thin, transparent baffle extending above the crop canopy before circulating downward again. Inlet atmosphere is dispersed into the fan stream, and some outlet air is captured in the middle of the donut hole on every downward pass and directed out of the chamber. The lid of the hydroponics pot is o-ring sealed to the container, and each plant holder is o-ring sealed to the lid (Fig. 5), so a fairly air-tight seal is achieved between root and shoot compartments. This is important in providing atmospheres of different composition to roots and shoots, and for measuring gas exchange in each compartment separately. Closed-cell Ethafoam plugs support one seedling in each of the 36 holders available. The depth of nutrient solution in the container is controlled by the length of an overflow tube. Uniform aeration of roots is provided by a circular aquarium wand in the bottom of the container. The root atmosphere is vented separately through an outlet in the lid.

A minimum amount of support equipment is needed for environmental control in the Minitron system (Fig. 6). An oilless, teflon-piston-driven air compressor is used to provide continuous air exchange for root and shoot compartments. The air is first dried to keep H₂O out of the flow valves; it is then Purafil-filtered to eliminate unsaturated hydrocarbons, mixed in

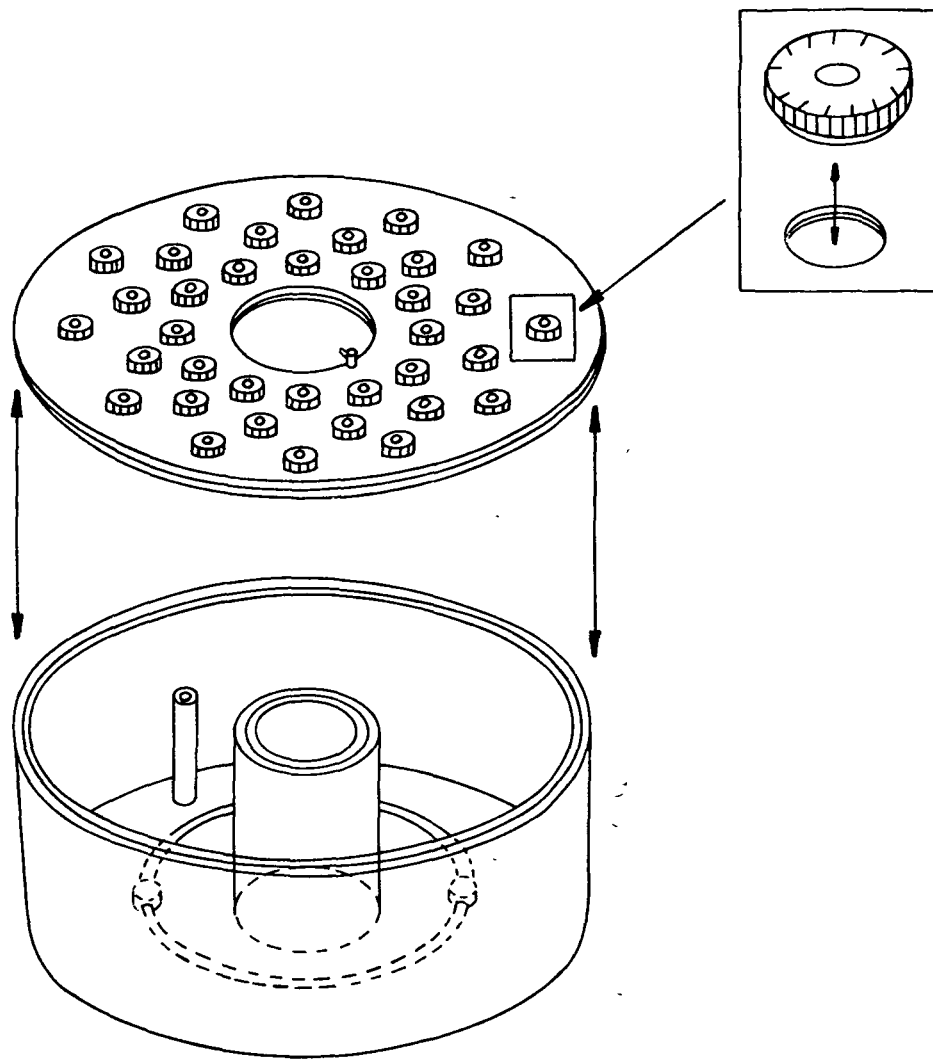

Figure 5. Donut-shaped hydroponics container including o-ring-sealed lid and individual plant holders, overflow tube, and circular aquarium wand.

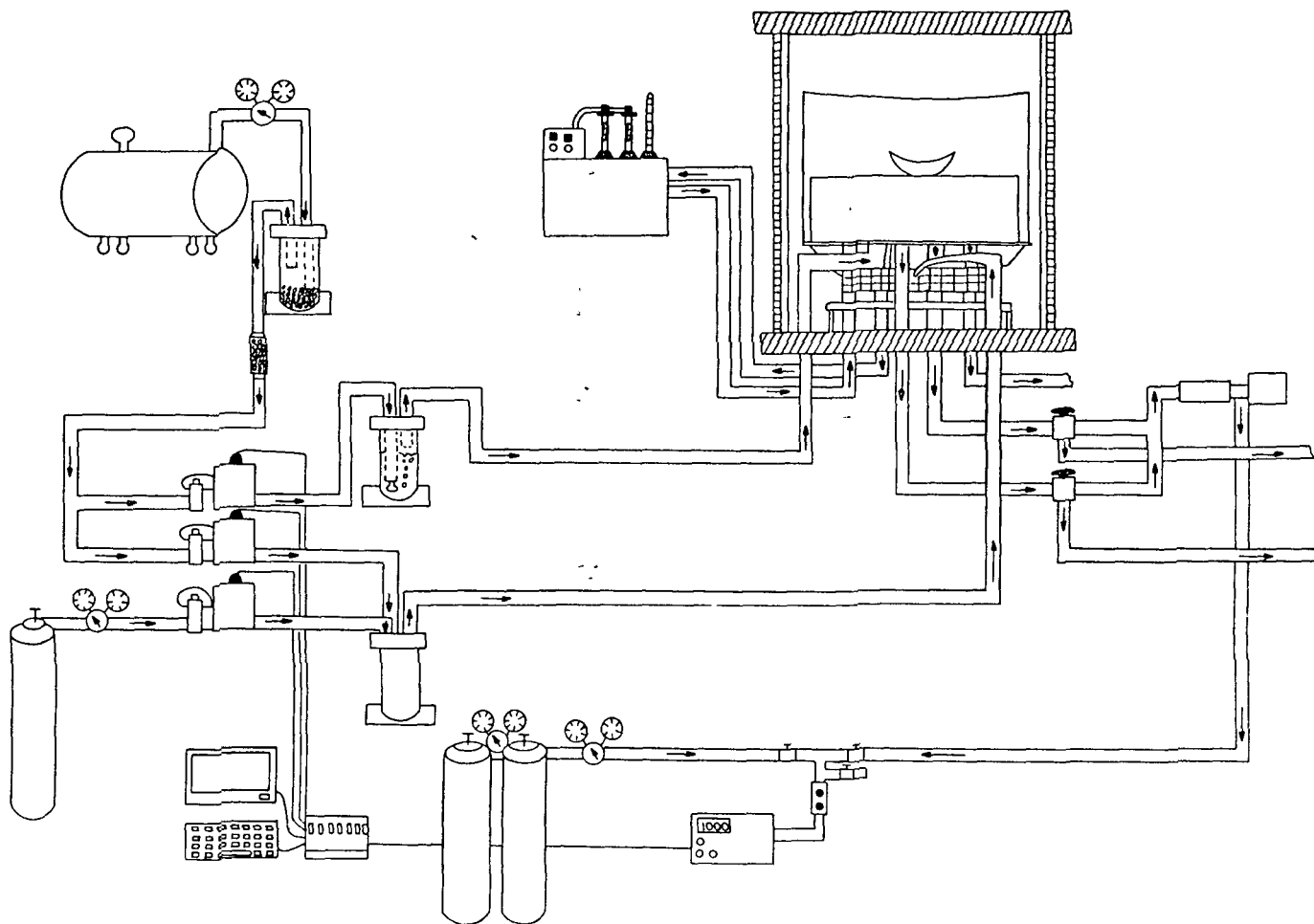

Figure 6. Environmental support equipment for the Minitron II plant growth system, including temperature control system, flowing atmosphere composition and flow rate system, CO₂ infrared gas analyzer, mass flow controller, and dedicated micro-computer.

a pre-determined proportion with pure CO₂, the mixture re-humidified, and metered at a controlled rate into the shoot compartment of the chamber. Air to pass through the root compartment is humidified without additional CO₂ injection. Outlet gases are either vented from the room or directed through an infrared CO₂ gas analyzer (IRGA). A recent acquisition is a computer-assisted mass flow control system, which adjusts a proportioning valve in response to signals from a computer, which in turn takes its cues from the IRGA. Software is being developed to maintain a constant level of CO₂ in the chamber even as plant demand for CO₂ changes. Gas exchange rates will be determined by the amount of CO₂ required to maintain CO₂ homeostasis in the chamber. We have used elevated CO₂ in the chambers for some time, but not with this sophisticated degree of CO₂ control. A thermostatted water bath circulates coolant through the chamber heat exchanger, and is equipped with a photocell and two thermoregulators so that it can automatically switch from day to night set-point temperatures and vice versa.

The inside of the chambers usually is covered with condensation during the dark period, but this soon burns off under a radiation load. Output from supplemental lamps is filtered through several inches of water to alleviate the load on the heat exchange system. Because growth space within the chambers is limited, we do not carry all 36 of the original

seedlings to harvest. Instead, a fixed number are harvested at regular intervals so that those remaining are uniformly spaced. This makes growth dynamics analysis possible, which is a powerful tool for determining productivity rates, photosynthetic efficiency, and how they change over time.

In fact, our experimental approach involves measuring growth dynamics at different stages of the growth curve. Lettuce growth follows a sigmoid pattern of cumulative growth. Lag and plateau phases are not particularly active periods of biomass assimilation. In our studies, we generally harvest while the plants are still in exponential growth, but the lag represents a significant delay. It will be helpful to find ways to shorten it, but to date most of our effort has been directed toward maximizing exponential growth.

After a lag phase of about 11 days, 'Waldmann's Green' leaf lettuce enters a shallow rate of exponential growth at 450 $\mu\text{mol s}^{-1} \text{m}^{-2}$ of PAR and 350 $\mu\text{l l}^{-1}$ CO_2 , and this response is quite uniform in 2 separate Minitron chambers (Fig. 7). However, growth was increased by raising CO_2 in one chamber to 1000 $\mu\text{l l}^{-1}$. In another experiment conducted at 350 $\mu\text{l l}^{-1}$ CO_2 , one chamber was exposed to a PPFD of 925 and another to 450 $\mu\text{mol s}^{-1} \text{m}^{-2}$ for 20 h day^{-1} , and the lettuce under higher light yielded better (Fig. 8). This semilog plot includes only the

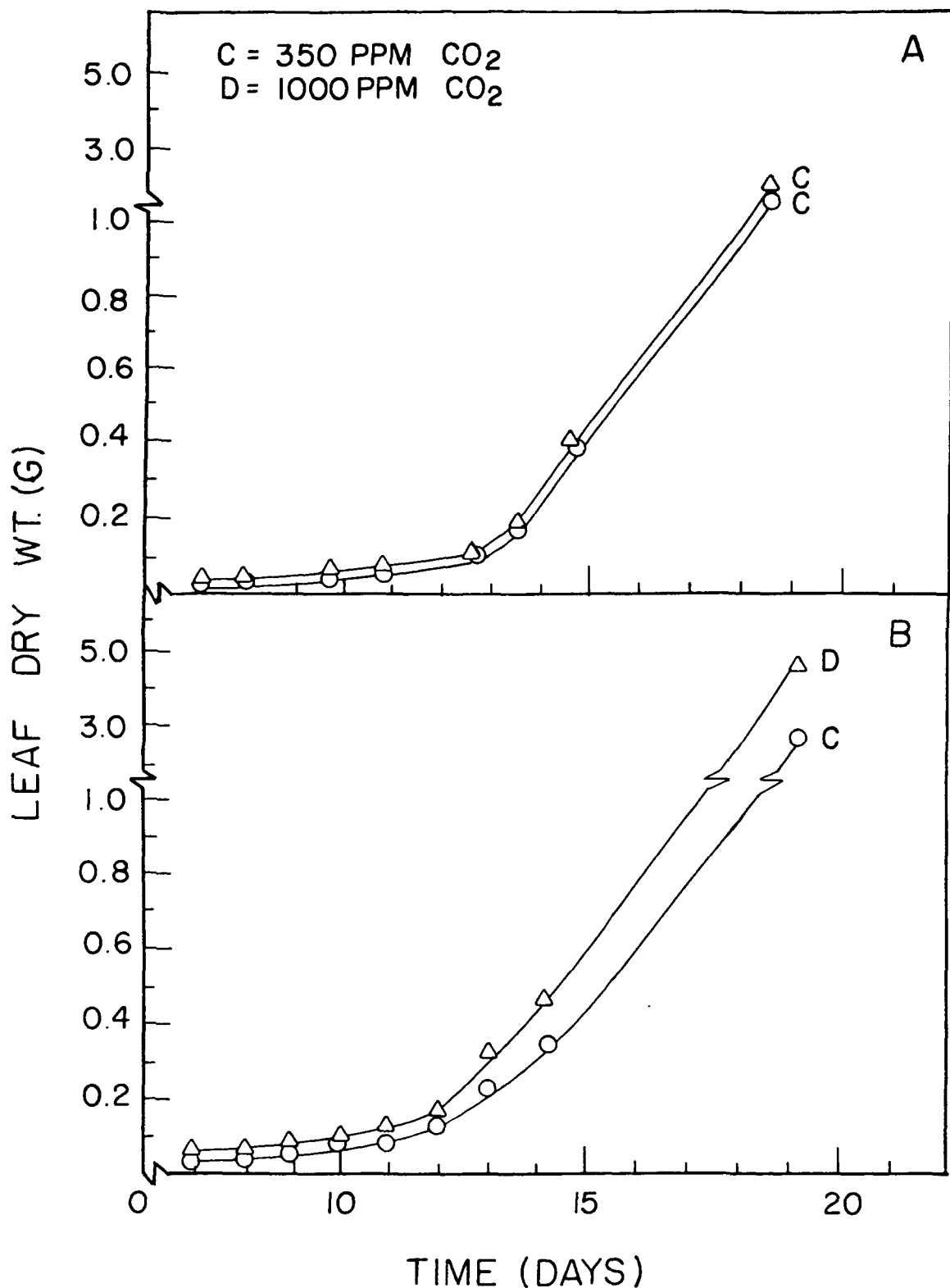

Figure 7. Growth profile of 'Waldmann's Green' leaf lettuce at $450 \mu\text{mol s}^{-1} \text{m}^{-2}$ of PAR + $350 \mu\text{l l}^{-1} \text{CO}_2$ in 2 separate Minitron II chambers (top), and at $1000 \mu\text{l l}^{-1} \text{CO}_2$ in one chamber and at 350 in another, both at the same PPFD (bottom).

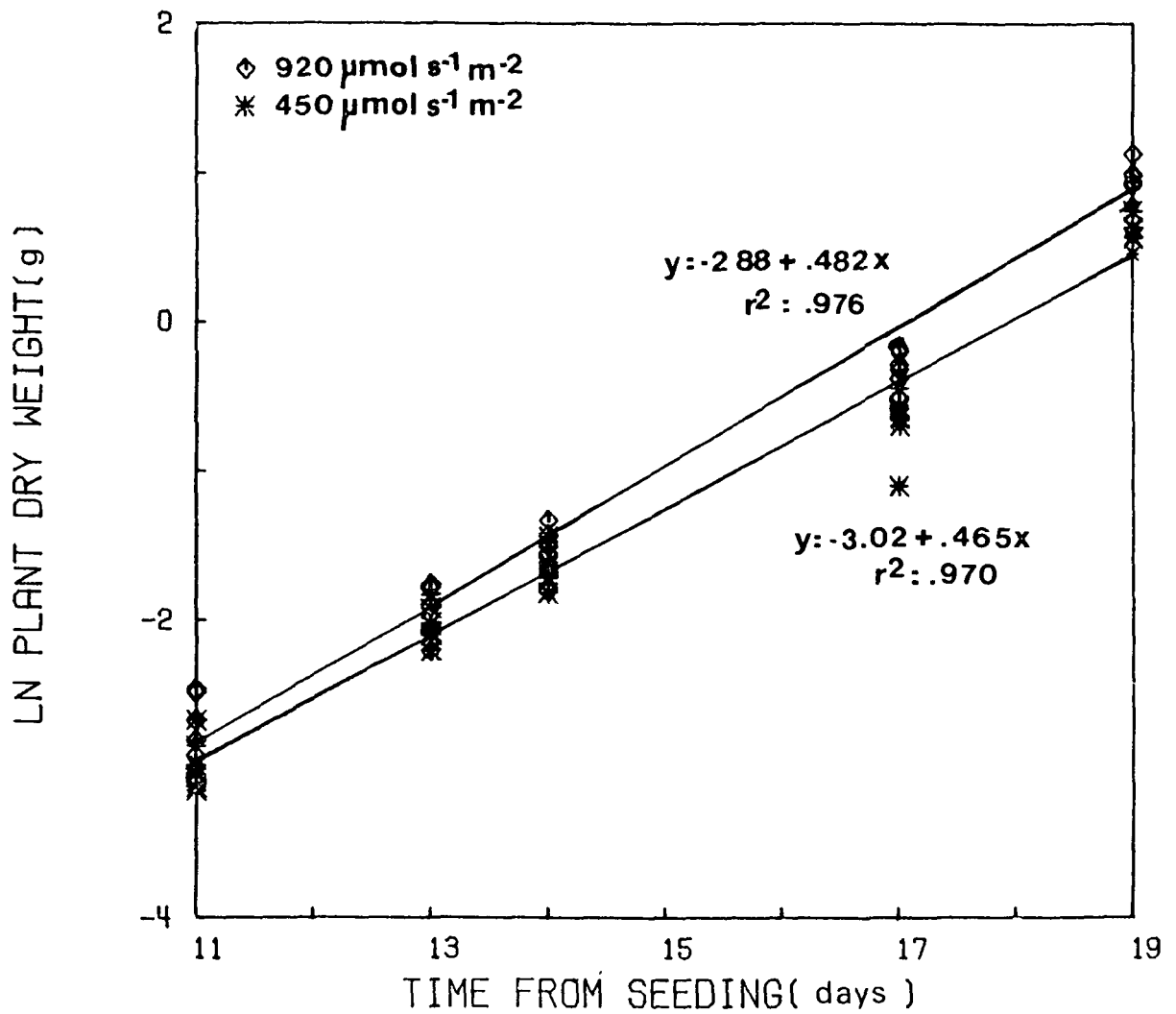

Figure 8. Semilog plot of plant dry weight over time for 'Waldmann's Green' leaf lettuce during exponential growth under either 920 or 450 $\mu\text{mol s}^{-1} \text{m}^{-2}$ at 350 $\mu\text{l l}^{-1} \text{CO}_2$.

exponential phase of growth. This type of plot straightens out curved lines, and its slope represents the relative growth rate (RGR) of the plants. In fact, the coefficient of the X term in the regression equation is mean RGR over that time interval. A comparison of RGR at high CO₂ + low light vs. that at low CO₂ + high light indicates that the cheaper CO₂ is slightly more effective than the high light when each are used alone.

When light and CO₂ were enhanced simultaneously, such as CO₂ to 1000 $\mu\text{l l}^{-1}$ and PPFD to 905 $\mu\text{mol s}^{-1} \text{m}^{-2}$, there was a synergistic interaction leading to enhanced RGR and yield (Fig. 9). When CO₂ was raised to 1500 $\mu\text{l l}^{-1}$, exponential growth was enhanced even further. To determine whether energy and resources can be saved, these optimizing treatments were initiated either 3 days before exponential growth normally begins, or 2 days after. Starting treatment early clearly had no benefit, and starting it late caused the exponential rise to lag. For treatment initiated on day 11, RGR during early exponential growth is extremely high (Table 1); in fact, for high light + high CO₂, the period from about 11 to 13 days gave the highest RGRs we have measured! Unfortunately, they decline rapidly, and one wonders whether there is any need to continue high light treatment much beyond day 13. We are investigating this possibility.

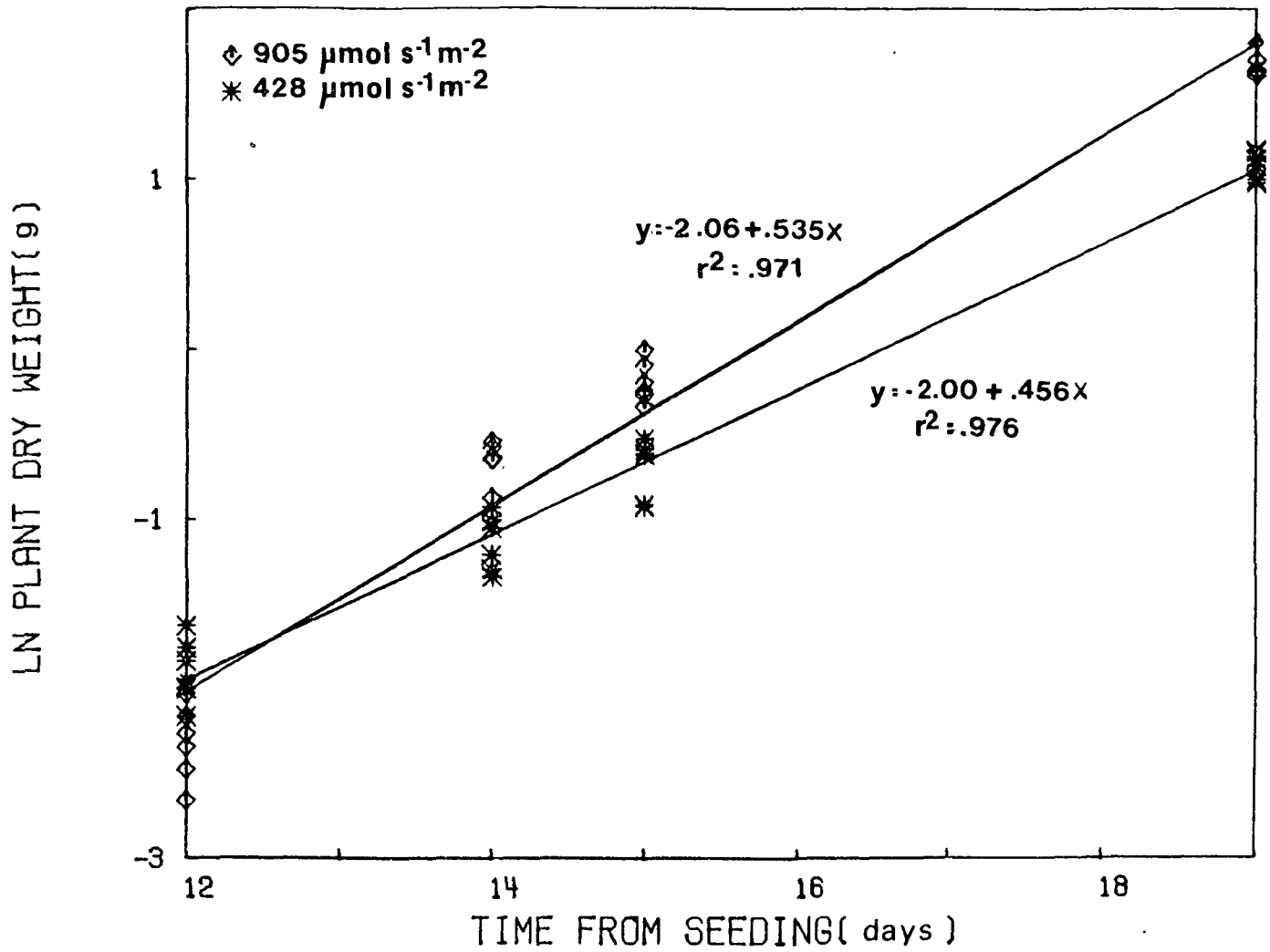

Figure 9. Effect of simultaneous enhancement of CO_2 (to $1000 \mu\text{l l}^{-1}$) and PPF (to $905 \mu\text{mol s}^{-1} \text{m}^{-2}$) on exponential growth rate of 'Waldmann's Green' leaf lettuce.

Table 1. Change in RGR of 'Waldmann's Green' during exponential growth as a function of PPFD at high CO₂.

Growth period (days)	Relative growth rate @ 1500 $\mu\text{l}\cdot\text{l}^{-1}$ CO ₂	
	Photosynthetic photon flux density ($\mu\text{mol}\cdot\text{s}^{-1}\cdot\text{m}^{-2}$)	
	450	900
	($\text{mg}\cdot\text{g}^{-1}\cdot\text{day}^{-1}$)	
12-13	603	909
13-15	544	562
15-19	416	501

We also are interested in the spectral emission of lamps used with the Minitron system. High dosages of HPS radiation did not work well here either, but we have had some success with various combinations of IC, MH, and FL lamps. For instance, when low-PPFD MH was compared with equivalent PPFD from IC + FL, lettuce yielded no better under one regime than the other. However, if PPFD was increased to 800 $\mu\text{mol s}^{-1} \text{m}^{-2}$ for both regimes in the presence of high CO₂, the IC/FL source was superior to the MH source (Fig. 10). Whether leaf lettuce actually prefers wavelengths present in the emissions from incandescent lamps currently is under investigation. Although incandescent lamp efficiency is low, improvements are forthcoming. We now use "Capsylite" IC lamps, which, unlike standard flood lamps, maintain most of their output as they age.

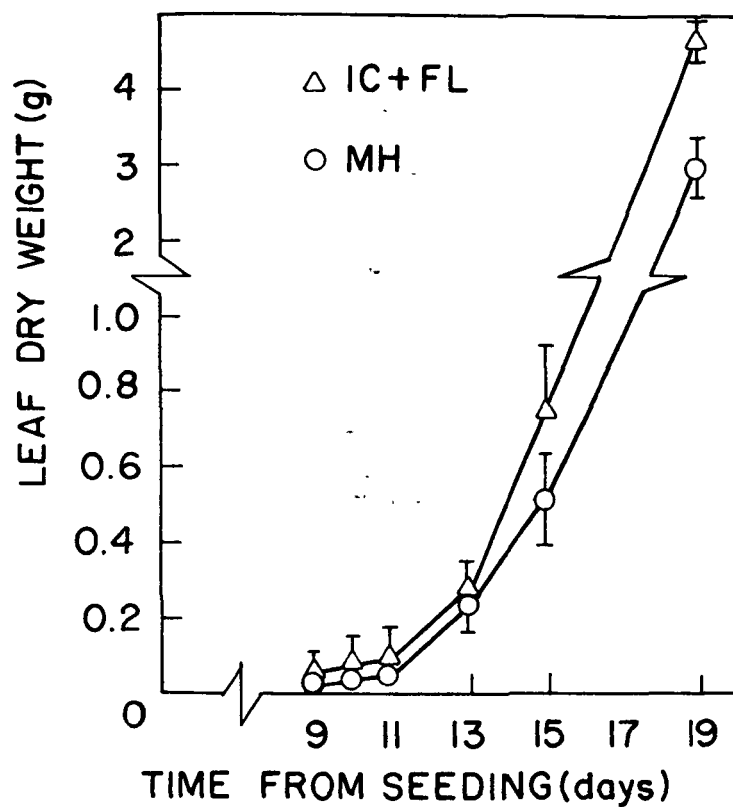

Figure 10. Growth profile of 'Waldmann's Green' lettuce under 1C (68% input wattage) + FL radiation (triangles) vs. MH radiation (circles). PPFD of both lighting regimes was $800 \mu\text{mol s}^{-1} \text{m}^{-2}$.

A lettuce crop grown for 19 days in a Minitron has not quite closed its leaf canopy at harvest. However, lettuce grown for 23 days develops a tightly solid foliar canopy. This mutual crowding greatly diminishes the RGR of individual plants during their last few days of growth, even under optimizing conditions, but those plants still exhibit superior growth compared to widely-spaced plants grown under standard growth chamber conditions (Table 2).

Table 2. Effect of elevated CO₂ concentrations and 900 $\mu\text{mol s}^{-1} \text{m}^{-2}$ of PAR on various growth parameters of 23-day-old 'Waldmann's Green' leaf lettuce.

Growth parameter	CO ₂ concentration ($\mu\text{l}\cdot\text{l}^{-1}$)	
	1000	1500
	(g·plant ⁻¹)	
Leaf fresh weight	96.00 ± 5.22 a ^z	106.48 ± 8.60 b
Leaf dry weight	8.98 ± 0.33 a	10.47 ± 0.41 b
Stem dry weight	0.59 ± 0.06 a	0.79 ± 0.09 b
Root dry weight	1.47 ± 0.07 a	1.75 ± 0.04 b
Plant dry weight	11.05 ± 0.17 a	13.01 ± 0.21 b

^zMean separation within rows by t-test at the 5% level of significance.

We have begun to test effects of plant growth regulators (PGRs) on lettuce growth concomitant with optimizing environmental conditions. For example, the 30-carbon primary

alcohol triacontanol tends to have promotive effects on yield, but formulation problems still prevent consistent performance with this chemical. With fresh, colloiddally-dispersed triacontanol sprayed on during lag phase, stimulatory effects disappear after the first few days of exponential growth. With or without triacontanol, per plant yield of 'Waldmann's Green' under optimizing conditions is excellent after 19 days (Table 3). When expressed on an area-occupied basis, crop growth rate (CGR) during exponential growth was 55 to 60 $\text{gDW m}^{-2} \text{ day}^{-1}$, and this does not even involve complete closure of the canopy yet. This compares with a typical CGR of 2.6 $\text{g m}^{-2} \text{ day}^{-1}$ over an entire production cycle for lettuce under field conditions.

In conclusion, we plan to extend our investigations of optimum lamp types; evaluate effects of other PGRs; fine-tune the timing of application of optimizing treatments with the aim of conserving energy and resources; use gas exchange rates of small crop canopies in the Minitrons to identify short and long-term plant response to optimizing treatments; and attempt to shorten the lag phase of the growth curve. Learning how to effectively modulate photosynthetic activity of vegetative canopies on a somewhat larger scale by manipulating light level and duration and/or CO_2 level could have important implications for systems control in CELSS.

Table 3. Effects of triacontanol applied twice during lag phase on various growth parameters of 19-day-old 'Waldmann's Green' lettuce. Plants also were exposed to high CO₂/high light treatment beginning on day 11.

Growth parameter	-TRIA	+10 ⁻⁷ g l ⁻¹ TRIA
	(g·plant ⁻¹)	
Leaf fresh weight	49.30 ± 6.76 a ^Z A ^Y	57.64 ± 3.77 bB
Leaf dry weight	4.93 ± 0.64 aA	5.62 ± 0.52 aB
Stem dry weight	0.34 ± 0.08 aA	0.36 ± 0.05 aA
Root dry weight	0.97 ± 0.08 aA	1.18 ± 0.08 bB
Plant dry weight	6.25 ± 0.72 aA	6.99 ± 0.65 aB
	(g·m ⁻² ·day ⁻¹)	
Crop growth rate	55.05 ± 7.04 aA	60.48 ± 9.07 aA

^ZDifferent lower case letters within rows different according to t-test at the 5% level of significance.

^YDifferent upper case letters within rows different according to t-test at the 10% level of significance.

General References

- Hoff, J.E., J.M. Howe, and C.A. Mitchell. 1982. Nutritional and cultural aspects of plant species selection for a controlled ecological life support system. NASA contractor report 166324.
- Knight, S.L. and C.A. Mitchell. 1983. Enhancement of lettuce yield by manipulation of light and nitrogen nutrition. J. Amer. Soc. Hort. Sci. 108:750-754.
- Knight, S.L. and C.A. Mitchell. 1983. Stimulation of lettuce productivity by manipulation of diurnal temperature and light. HortScience 18:462-467.
- Tibbitts, T.W. and D.K. Alford. 1982. Controlled ecological life support system: use of higher plants. NASA conference publication 2231.