

NASA CR 178004

NASA Contractor Report 178004

NASA-CR-178004
19860010618

In-Flight Acoustic Measurements on a Light Twin-Engined Turboprop Airplane

J.F.Wilby , C.D.McDaniel and E.G.Wilby

**BBN Laboratories Inc.
Canoga Park, CA 91303**

FOR REFERENCE

SEARCHED INDEXED

Contract NAS1-16521

November 1985

LIBRARY COPY

MAR 4 1986

LANGLEY RESEARCH CENTER
LIBRARY, NASA
HAMPTON, VIRGINIA



National Aeronautics and
Space Administration

Langley Research Center
Hampton, Virginia 23665

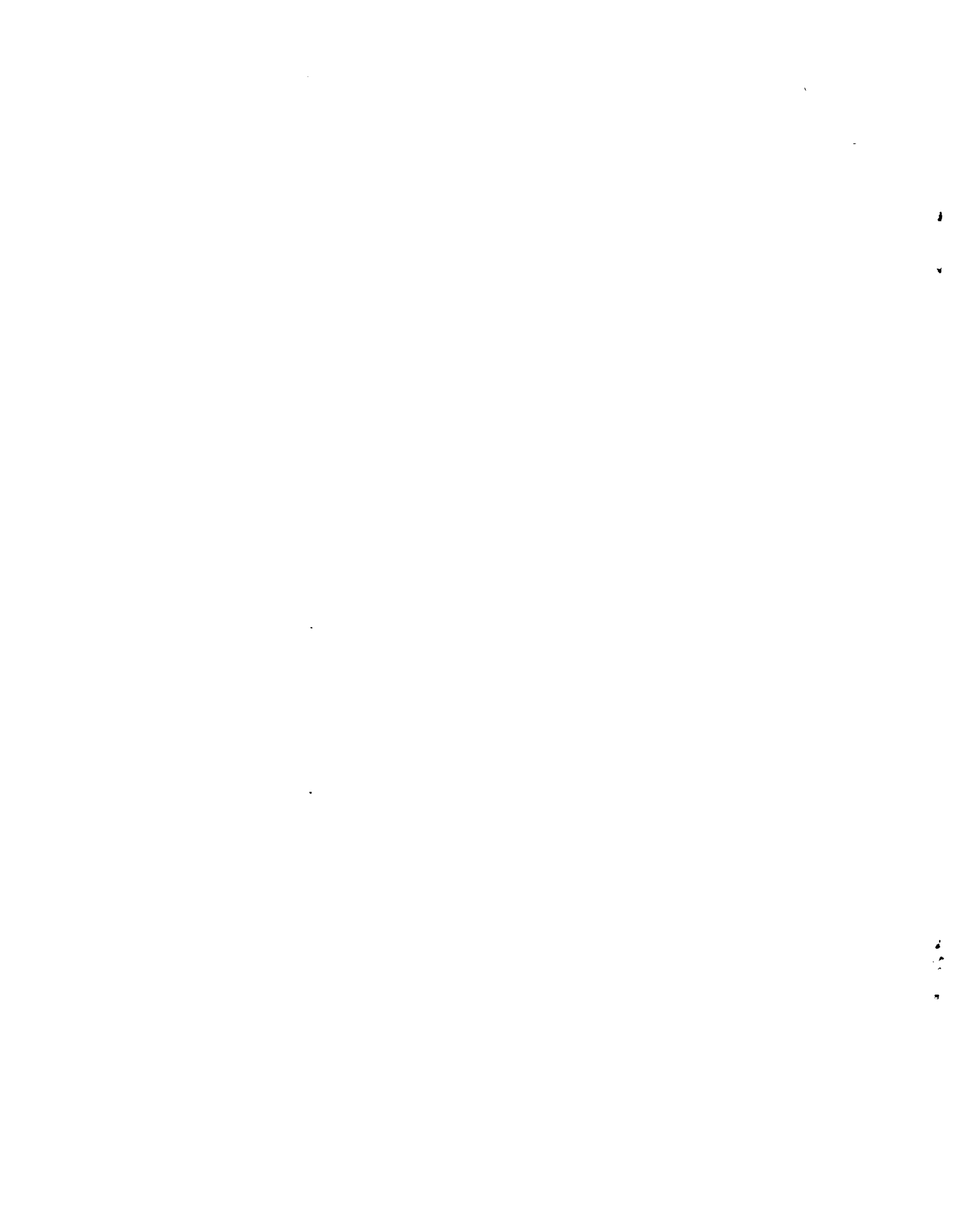

NASA Contractor Report 178004

IN-FLIGHT ACOUSTIC MEASUREMENTS ON A LIGHT TWIN-ENGINEED
TURBOPROP AIRPLANE

J. F. Wilby
C. D. Mc Daniel
E. G. Wilby

BBN Laboratories Incorporated
A Subsidiary of
Bolt Beranek and Newman Inc.
Canoga Park, California 91303

Contract NAS1-16521

November 1985

N86-20089#

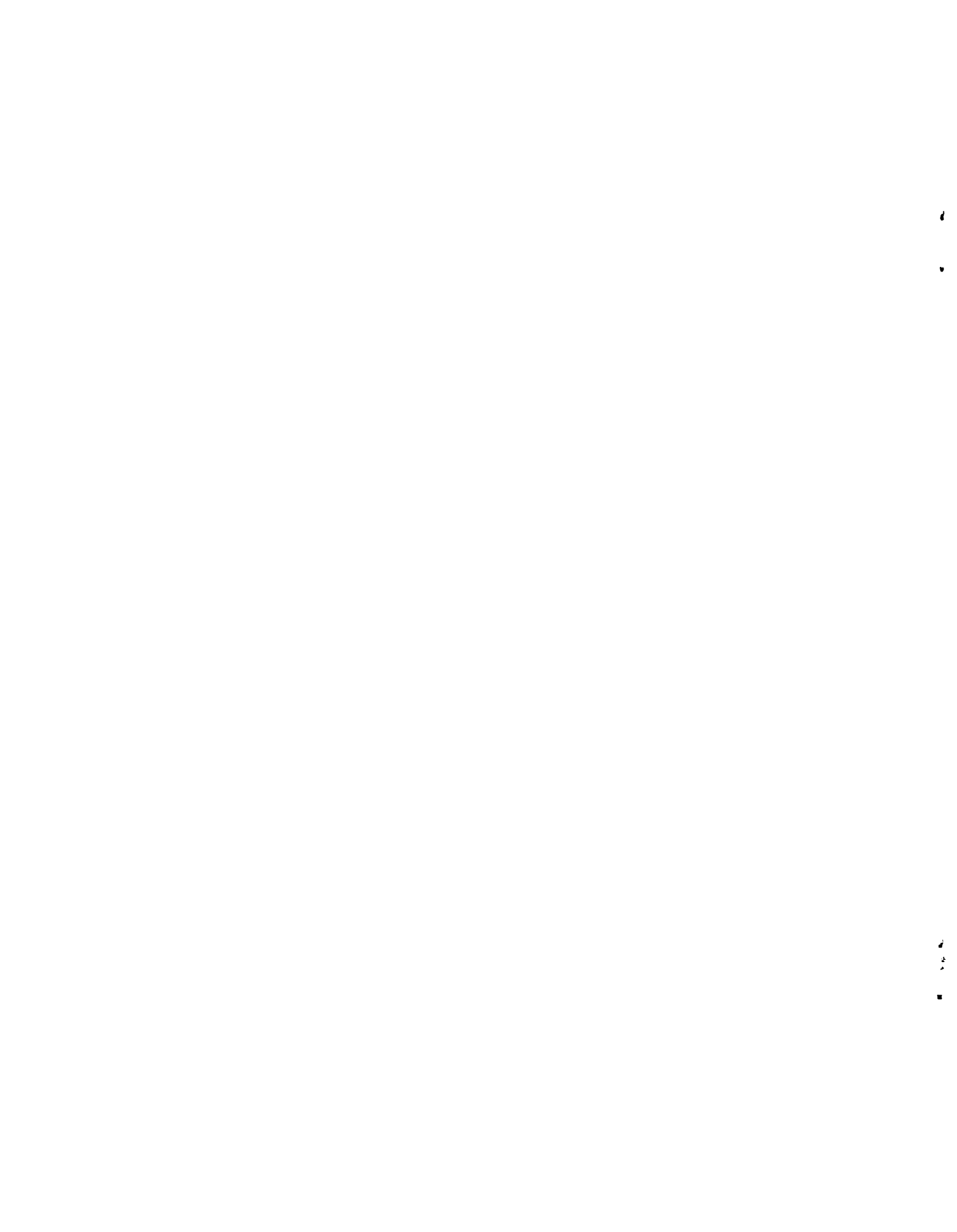

TABLE OF CONTENTS

<u>Section</u>	<u>Page</u>
1.0 INTRODUCTION	1
2.0 TEST DESCRIPTION	3
2.1 Test Airplane	3
2.2 Test Condition	7
2.3 Instrumentation	14
2.4 Interior Configuration	21
3.0 EXTERIOR FLUCTUATING PRESSURE FIELD	26
3.1 Narrowband Spectra	26
3.2 Harmonic Data Variability	33
3.3 Comparison of Port and Starboard Levels	43
3.4 Comparison with Simplified Predictions	46
3.5 Relative Phase	52
3.6 Turbulent Boundary Layer	56
3.7 One-Third Octave Band Spectra	57
4.0 SOUND LEVELS IN UNTREATED CABIN	60
4.1 Narrowband Spectra	60
4.2 Harmonic Data Variability	62
4.3 One-Third Octave Band Spectra	75
5.0 SOUND LEVELS IN TREATED CABIN	77
6.0 DISCUSSION	82
6.1 Cabin Pressurization	82
6.2 Sidewall Noise Reduction	92
6.3 Insertion Loss	102
7.0 CONCLUSIONS	114
7.1 Data Variability	114
7.2 Exterior Sound Pressure Levels	115
7.3 Interior Sound Pressure Levels	116
7.4 General Comments	117
REFERENCES	118

TABLE OF CONTENTS
Continued

<u>Section</u>	<u>Page</u>
APPENDIX:	
A. EXTERIOR FLUCTUATING PRESSURE LEVELS AT HARMONICS OF PROPELLER BLADE PASSAGE FREQUENCY	121
B. INTERIOR SOUND PRESSURE LEVELS AT HARMONICS OF PROPELLER BLADE PASSAGE FREQUENCY: BARE INTERIOR	129
C. INTERIOR SOUND PRESSURE LEVELS AT HARMONICS OF PROPELLER BLADE PASSAGE FREQUENCY: TREATED INTERIOR	149
D. ONE-THIRD OCTAVE BAND SPECTRA FOR EXTERIOR FLUCTUATING PRESSURES	157
E. ONE-THIRD OCTAVE BAND SPECTRA FOR INTERIOR SOUND PRESSURES: BARE INTERIOR	167
F. ONE-THIRD OCTAVE BAND SPECTRA FOR INTERIOR SOUND PRESSURES: TREATED INTERIOR	181
G. EFFECTS OF CABIN PRESSURIZATION ON CABIN SOUND PRESSURE LEVELS	195
H. NOISE REDUCTION FOR UNTREATED CABIN	199
I. NOISE REDUCTION FOR TREATED CABIN	205
J. INSERTION LOSS PROVIDED BY TREATMENT: NO ADJUSTMENTS FOR CHANGES IN EXTERIOR SOUND PRESSURE LEVELS	211
K. INSERTION LOSS PROVIDED BY TREATMENT: ADJUSTED FOR CHANGES IN EXTERIOR SOUND PRESSURE LEVEL	219

LIST OF FIGURES

<u>Figure</u>	<u>Page</u>
1. Test Airplane	4
2. Three-View Diagram of Test Airplane	5
3. Aircraft Station, Water Line, and Body Line Locations	6
4. Locations of Microphones Inside Cabin and On Exterior of Fuselage	17
5. Interior of Bare Cabin Showing Installed Instrumentation	19
6. External Microphone and Pressure Sensors	20
7. Samples of Sound-Absorbing Treatments	23
8. Sound-Absorbing Material Installed in Cabin	24
9. Narrowband Spectra of External Fluctuating Pressure Field Measured on Port Side of Fuselage. (Propellers Operating at Different RPM)	27
10. Narrowband Spectra of External Fluctuating Pressure Field Measured on Starboard Side of Fuselage. (Propellers Operating at Different RPM)	29
11. Narrowband Spectra of External Fluctuating Pressure Field Measured on Port Side of Fuselage During Single-Engine Operation	31
12. Narrowband Spectra of External Fluctuating Pressure Field Measured on Starboard Side of Fuselage During Single-Engine Operation	32
13. Variability of Harmonic Sound Levels on Exterior of Fuselage. (Component From Nearest Propeller, Port Side, Low RPM)	35
14. Variability of Harmonic Sound Levels on Exterior of Fuselage. (Component from Nearest Propeller, Port Side, High RPM)	37
15. Variability of Harmonic Sound Levels on Exterior of Fuselage. (Component from Nearest Propeller, Starboard Side, Low RPM)	39
16. Variability of Harmonic Sound Levels on Exterior of Fuselage. (Component from Nearest Propeller, Starboard Side, High RPM)	41
17. Comparison of Range of Harmonic Sound Pressure Levels Generated by Port and Starboard Propellers (Flights 1-4)	44
18. Comparison of Measured and Predicted Propeller Harmonic Sound Pressure Levels: 3,000 m Altitude . . .	48

LIST OF FIGURES
Continued

<u>Figure</u>	<u>Page</u>
19. Comparison of Measured and Predicted Propeller Harmonic Sound Pressure Levels: 4,600 m Altitude, Two-Engine Operation	49
20. Comparison of Measured and Predicted Propeller Harmonic Sound Pressure Levels: 4,600 m Altitude, Single-Engine Operation	50
21. Comparison of Measured and Predicted Propeller Harmonic Sound Pressure Levels: 9,100 m Altitude	51
22. Typical Propeller Pressure Time Histories Measured on Exterior of Fuselage	53
23. Comparison of Propeller Pressure Time Histories and Cross Correlation Function for the Two Signals	54
24. Comparison of Measured Exterior One-Third Octave Band Pressure Spectra and Predicted Turbulent Boundary Layer Pressure Levels	58
25. Typical Narrowband Sound Pressure Spectrum Measured in Untreated Cabin	61
26. Narrowband Spectra of Cabin Sound Pressure Levels at Location 3; Port Propeller, Low RPM; Starboard Propeller, High RPM	63
27. Narrowband Spectra of Cabin Sound Pressure Levels at Location 3; Port Propeller, High RPM; Starboard Propeller, Low RPM	64
28. Narrowband Spectra of Cabin Sound Pressure Levels at Location 3; Single-Engine Operation	65
29. Comparison of Harmonic Sound Pressure Levels Measured in Untreated Cabin Under Repeated Flight Conditions; Propellers at Different RPM; Microphone Location 3	66
30. Comparison of Harmonic Sound Pressure Levels Measured in Untreated Cabin Under Repeated Flight Conditions; Propellers at Different RPM; Microphone Location 6	67
31. Comparison of Harmonic Sound Pressure Levels Measured in Untreated Cabin Under Repeated Flight Conditions; Propellers at Same RPM; Microphone Location 3	69

LIST OF FIGURES
Continued

<u>Figure</u>	<u>Page</u>
32. Comparison of Harmonic Sound Pressure Levels Measured in Untreated Cabin Under Repeated Flight Conditions; Propellers at Same RPM; Microphone Location 6	70
33. Range of Harmonic Sound Pressure Levels Measured in Untreated Cabin for Flights 1 through 3. Propellers at Same RPM; Data Averaged Over Four Nominal Synchrophase Settings	72
34. Time Histories of Harmonic Sound Pressure Levels in Cabin; Two Engines Operating at Different RPM (Condition 9)	74
35. Time Histories of Harmonic Sound Pressure Levels in Cabin; Two Engines Operating at Same RPM (Condition 8)	76
36. Effect of Fiberglass Treatment on Cabin Narrowband Sound Pressure Level Spectra: Altitude 9,100 m	78
37. Effect of Fiberglass Treatment on Cabin Narrowband Sound Pressure Level Spectra: Altitude 4,600 m	80
38. Narrowband Spectra of Cabin Sound Pressure Levels at Location 3; Effect of Cabin Pressure Differential. (Airplane Altitude 3,000 m)	83
39. Change in Harmonic Sound Pressure Level in Cabin Due to Cabin Pressure Differential. Microphone Location 3; Port Propeller Component, High and Low RPM	85
40. Change in Harmonic Sound Pressure Level in Cabin Due to Cabin Pressure Differential. Microphone Location 3; Starboard Propeller Component, High and Low RPM	86
41. Change in Harmonic Sound Pressure Level in Cabin Due to Cabin Pressure Differential. Microphone Location 6; Port Propeller Component, High and Low RPM	87
42. Change in Harmonic Sound Pressure Level in Cabin Due to Cabin Pressure Differential. Microphone Location 6; Starboard Propeller Component, High and Low RPM	88
43. Change in One-Third Octave Band Sound Pressure Level in Cabin Due to Change in Cabin Pressure Differential; Microphone Location 3	89
44. Change in One-Third Octave Band Sound Pressure Level in Cabin Due to Change in Cabin Pressure Differential; Microphone Location 6	90

LIST OF FIGURES
Continued

<u>Figure</u>	<u>Page</u>
45. Harmonic Noise Reduction for Untreated Cabin: Flight 3, Exterior Port Microphone, Interior Microphone Location 6	93
46. Harmonic Noise Reduction for Untreated Cabin: Flight 3, Exterior Starboard Microphone, Interior Microphone Location 3	94
47. Harmonic Noise Reduction for Treated Cabin: Flight 4, Exterior Port Microphone, Interior Microphone Location 6	95
48. Harmonic Noise Reduction for Treated Cabin: Flight 4, Exterior Starboard Microphone, Interior Microphone Location 3	96
49. One-Third Octave Band Noise Reduction for Untreated Cabin: Flight 3, Exterior Port Microphone, Interior Microphone Location 6	98
50. One-Third Octave Band Noise Reduction for Untreated Cabin: Flight 3, Exterior Starboard Microphone, Interior MicroPHONE Location 3	99
51. One-Third Octave Band Noise Reduction for Treated Cabin: Flight 4, Exterior Port Microphone, Interior Microphone Location 6	100
52. One-Third Octave Band Noise Reduction for Treated Cabin: Flight 4, Exterior Starboard Microphone, Interior Microphone Location 3	101
53. Harmonic Insertion Loss Provided by Fiberglass Treatment: Port Propeller Component, Interior Microphone 3. (No Adjustment for Change in Exterior Sound Pressure Level)	104
54. Harmonic Insertion Loss Provided by Fiberglass Treatment: Starboard Propeller Component, Interior Microphone 3. (No Adjustment for Change in Exterior Sound Pressure Level)	105
55. Harmonic Insertion Loss Provided by Fiberglass Treatment: Port Propeller Component, Interior Microphone 6. (No Adjustment for Change in Exterior Sound Pressure Level)	106
56. Harmonic Insertion Loss Provided by Fiberglass Treatment: Starboard Propeller Component, Interior Microphone 6. (No Adjustment for Change in Exterior Sound Pressure Level)	107

LIST OF FIGURES
Continued

<u>Figure</u>	<u>Page</u>
57. Harmonic Insertion Loss Provided by Fiberglass Treatment: Starboard Propeller Component, Interior Microphone 3. (Adjusted for Change In Exterior Sound Pressure Level)	108
58. Harmonic Insertion Loss Provided by Fiberglass Treatment: Port Propeller Component, Interior Microphone 6. (Adjusted for Change in Exterior Sound Pressure Level)	109
59. One-Third Octave Band Insertion Loss Provided by Fiberglass Treatment: Interior Microphone Location 3. (No Adjustment for Change in Exterior Sound Pressure Level)	111
60. One-Third Octave Band Insertion Loss Provided by Fiberglass Treatment: Interior Microphone Location 6. (No Adjustment for Change in Exterior Sound Pressure Level)	112

LIST OF TABLES

<u>Table</u>	<u>Page</u>
1. Nominal Flight Test Conditions	8
2. Flight Test Conditions: Flight #1	9
3. Flight Test Conditions: Flight #2	10
4. Flight Test Conditions: Flight #3	11
5. Flight Test Conditions: Flight #4	12
6. Fuselage Skin Temperature Measured During Flight #4. .	15
7. Locations of Cabin Microphones	18
8. Locations of Transducers on Fuselage Exterior	18
9. Measured and Predicted Exterior Overall Sound Pressure Levels Associated with Propeller Discrete Frequency Sound	45
10. Relative Phase Between Port and Starboard Propellers .	56
11. Assumed Acoustic Absorption Properties	113

ACKNOWLEDGMENT

The experimental investigation described in this report was performed by BBN Laboratories Incorporated under Task 15 of NASA Contract NAS1-16521, with Dr. John S. Mixson as Technical Monitor. However, the program received considerable support from the Gulfstream Aerospace Company, who provided the test airplane and flight crew free of charge. The authors wish to acknowledge this contribution. In addition, the authors would like to thank Gulfstream Aerospace staff members Mr. R. O'Neal, Manager of Environmental Engineering, Mr. J. Morehead, Manager of Test Engineering, and Mr. A. Hernandez, Test Pilot, for their significant contributions to the test program.

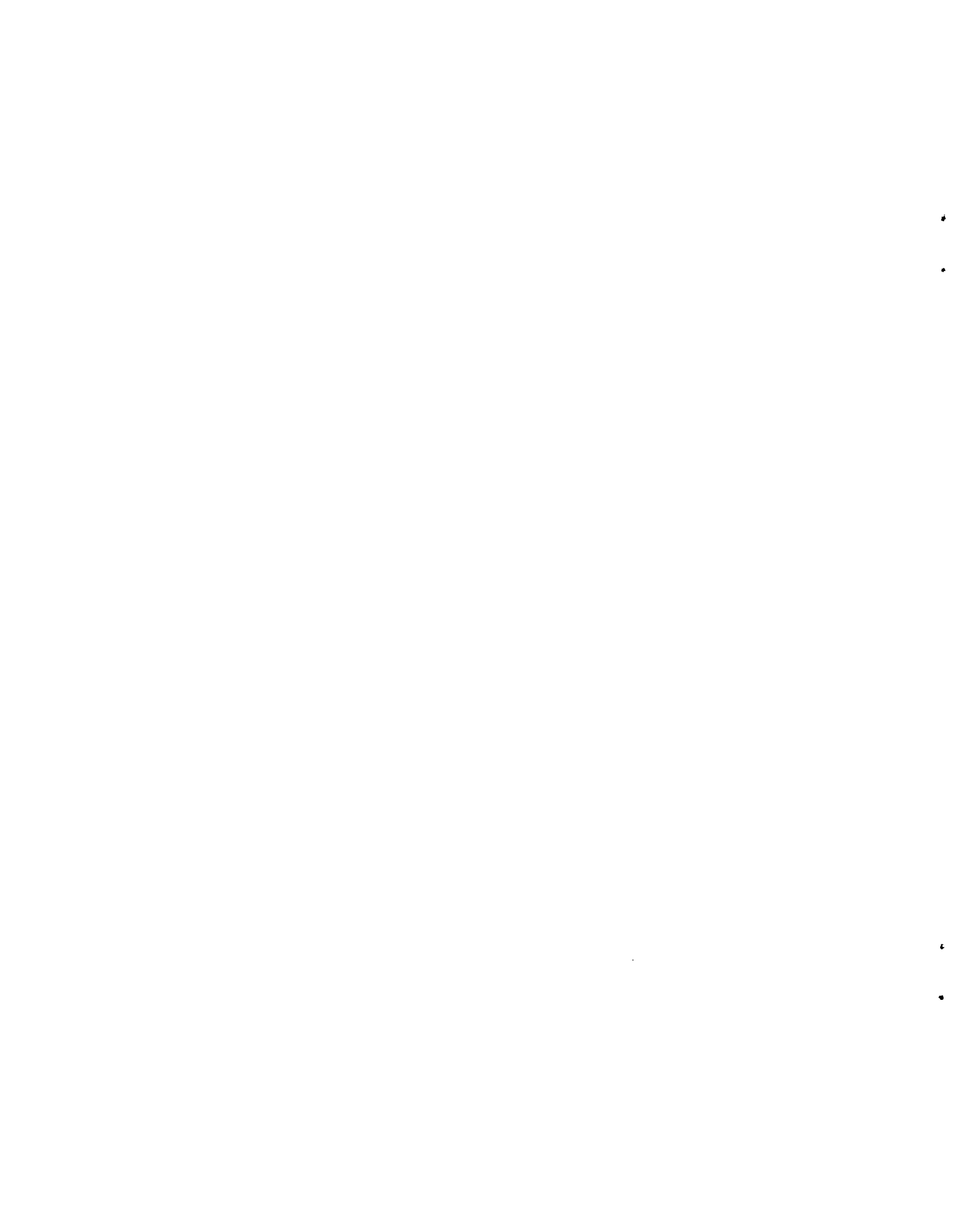

1.0 INTRODUCTION

As part of a comprehensive NASA program to reduce sound levels in general aviation aircraft, several analytical, laboratory, ground run-up, and flight studies have been performed on light, twin-engined, propeller-driven airplanes [1-19]. All the aircraft investigated were of the same basic configuration, but in the earlier studies an unpressurized, piston-engined airplane was used while, later, a pressurized, turboprop model was considered. Flight measurements were performed on the turboprop airplane in 1981 to evaluate an experimental sidewall treatment. The results of these measurements [9, 19] showed a large variability in the data so that it was difficult to evaluate the acoustic performance of the treatment. In addition, the treatment did not provide the desired noise reductions. Consequently, a second series of flight tests was planned with the two main objectives of, first, establishing a test procedure to minimize the variability of the data and, secondly, evaluating the noise reduction characteristics of a sidewall treatment designed to provide high transmission loss.

The first phase of the flight test series was conducted in May 1984. Four flights were performed, three with an untreated cabin and one with the cabin lined with 5-cm (2-inch) thick fiberglass batts. Unfortunately, the test airplane was not available for the second phase of the flight test series. Consequently, it was not possible to evaluate the new sidewall treatment. This report presents data for the first phase only.

Data from the four flights are presented in a series of appendices included in this report. The main text of the report provides descriptions of the test airplane, test procedures and instrumentations of the test airplane (Section 2) followed by discussion

of the results. Section 3 discusses the exterior sound field, Section 4 the interior sound field in the untreated cabin, and Section 5 the sound field in the cabin lined with fiberglass. A general discussion of the results is provided in Section 6.

2.0 TEST DESCRIPTION

2.1 Test Airplane

The airplane used for the tests was a Gulfstream Aerospace Commander 695A (Serial Number 96000, Registration N81502). This airplane is a high-wing business aircraft with a maximum take-off weight of 5079kg (11,200 lb). It has a pressurized cabin and retractable landing gear. The particular aircraft used for the measurement program was an airplane operated by Gulfstream Aerospace Corporation in support of certification and engineering test requirements. Thus, the fuselage interior did not contain standard sidewall treatment or cabin furnishings.

The Commander 695A is powered by two AiResearch TPE331-10-501K single-shaft, turboprop engines which have a nominal rating of 610 kW (820 SHP). The engines drive Dowty Rotol three-bladed propellers with super-critical airfoil sections. The propellers have a diameter of 2.69m (106 inches) and the minimum clearance between the fuselage and the propeller tip is 0.36m (14 inches) or 0.13D, where D denotes the propeller diameter. The maximum rotational speed of the TPE331-10-501K engine is 41,800 rpm. There is a two-stage reduction gear box, with an overall gear ratio of 26.3:1 connecting the engine to the propeller. The maximum speed of the propeller is 1591 rpm and the direction of rotation is counter-clockwise when viewed from the rear. Engine exhausts are located on the outboard side of each nacelle.

Photographs of the test airplane are shown in Figure 1, and a three-view diagram is given in Figure 2. The fuselage structure of the Commander 695A is of conventional skin-longeron-frame construction. The thickness of the fuselage sidewall skin panels is typically 1.6mm (0.063 inch) and the longitudinal stiffeners consist mainly of longerons at vertical stations (water line) WL-10.00, WL-28.00 and WL-55.00, as shown in Figure 3. Locations

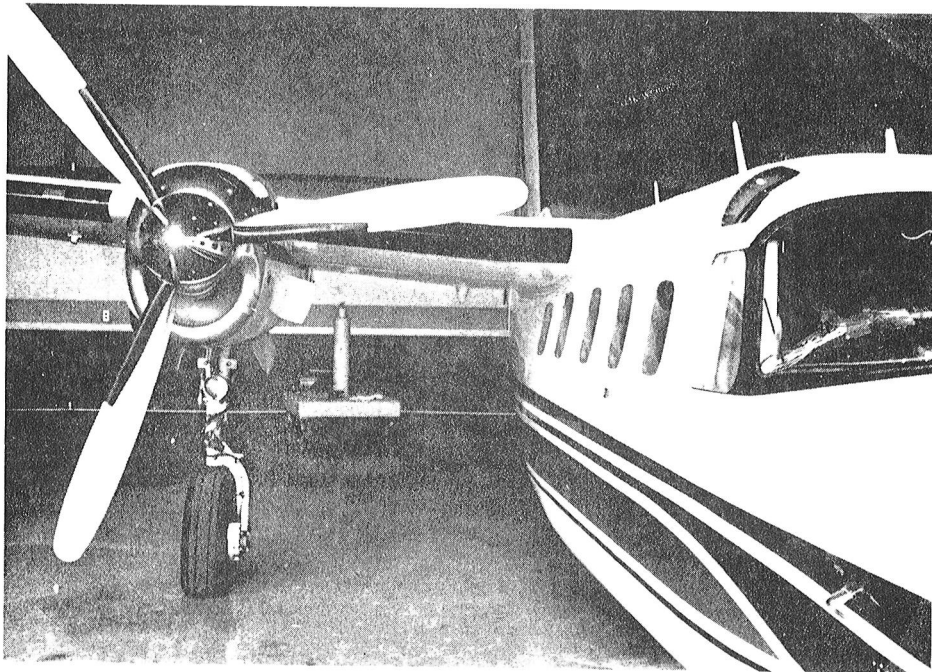

FIGURE 1. TEST AIRPLANE

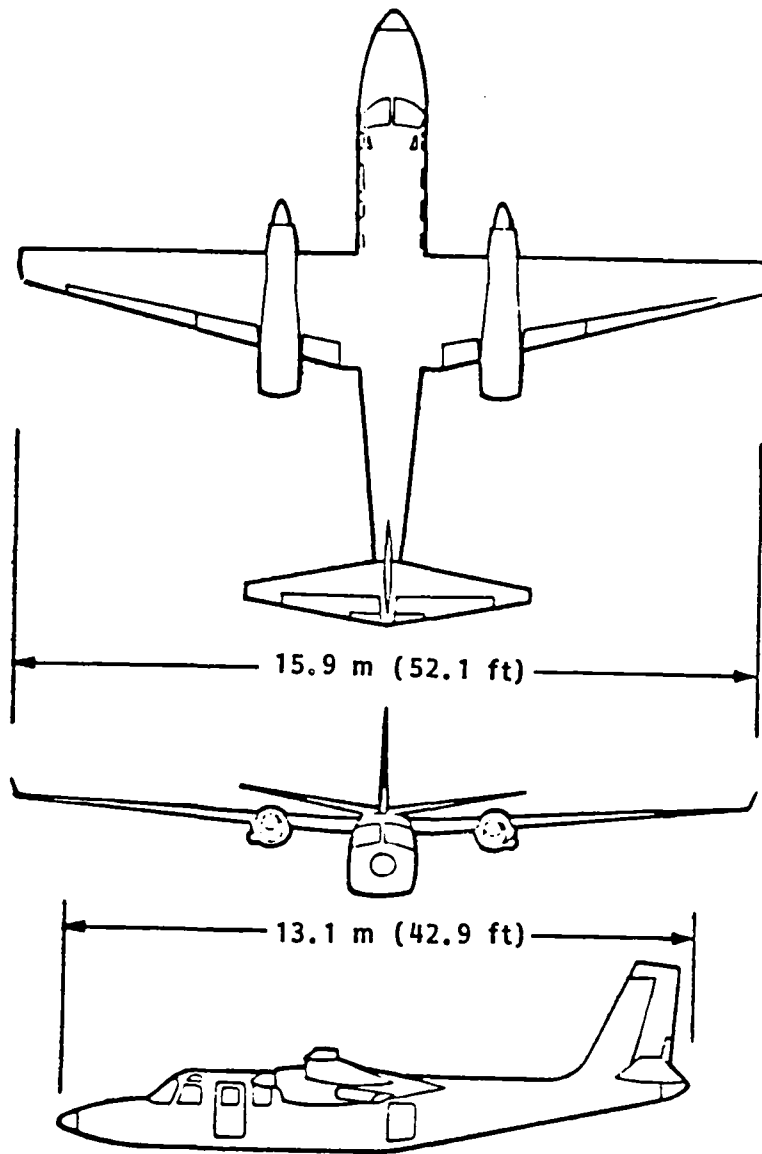

FIGURE 2. THREE-VIEW DIAGRAM OF TEST AIRPLANE

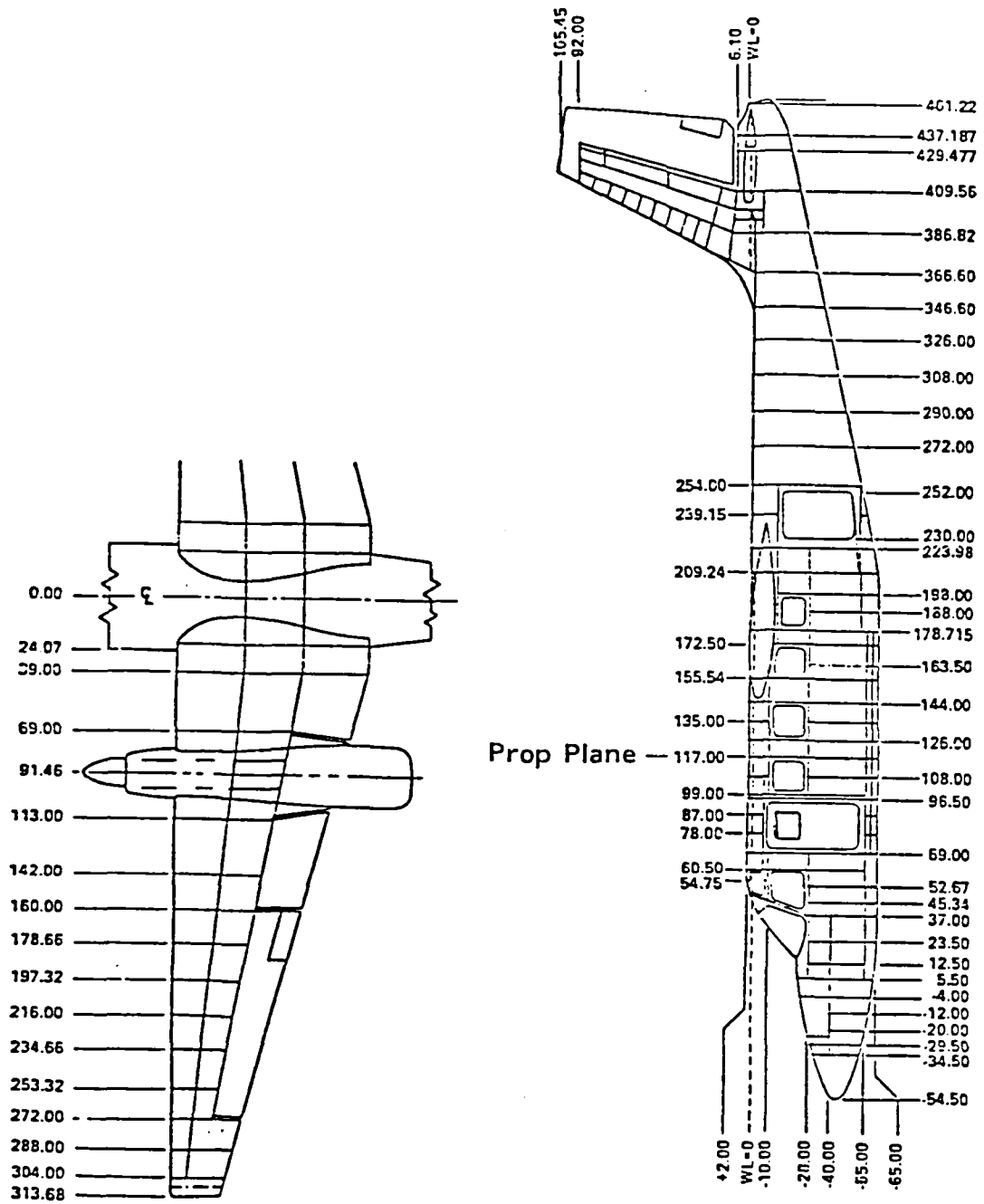

FIGURE 3. AIRCRAFT STATION, WATER LINE, AND BODY LINE LOCATIONS

of the frames and cabin windows are also shown in Figure 3, where station, body line and water line numbers are given in inches.

2.2 Test Conditions

Four flights were performed with the intention of repeating the same test conditions on each flight. The nominal test conditions are given in Table 1 and the actual conditions for each flight (logged by the flight test engineer in the copilot's seat) are listed in Tables 2 through 5. Unfortunately, the propeller synchrophaser* system was not operating during the fourth flight and several of the test conditions could not be achieved. The first three flights were performed with the cabin untreated. No changes were made to the cabin contents between these flights and the transducers were not moved. Following the third flight, the acoustic instrumentation was removed so that the fiberglass batts could be installed. The instrumentation was reinstalled prior to the fourth flight.

Flight #1 was conducted on the morning of 15 May 1984, originating and ending at Wiley Post Airport, Bethany, OK; data were recorded during the period 0935 hours to 1100 hours, CDT. Flights #2 and #3 were both conducted during the morning of 16 May 1984. Flight #2 originated at Wiley Post Airport and terminated at Nashville Airport, TN, data being recorded from 0725 hours to 0840 hours CDT. Flight #3 was the return flight to Wiley Post Airport, with the measurements being made between 1055 hours and 1210 hours. Flight #4 was a round trip from Wiley Post Airport on the afternoon of 17 May 1984; data were recorded from 1445 hours to 1555 hours.

*The word "synchrophaser" is used by industry to describe equipment which keeps a preset phase relationship between the two propellers while also keeping the propellers at the same rotational speed. The accuracy with which the relative phase is maintained can vary considerably between different types of synchrophasers.

TABLE 1
NOMINAL FLIGHT TEST CONDITIONS

CONDT. IDENT.	REMARKS	FLIGHT PRESSURE ALTITUDE m/ft	CABIN ALTITUDE m/ft	CABIN PRESSURE DIFFER. kNm ⁻² /psi	IAS kts	OUTSIDE AIR TEMP °F	PROPELLER OPERATING CONDITION						RELATIVE PHASE SETTING (2)
							PORT			STARBOARD			
							RPM	TORQUE (1)	POWER kW/SHP	RPM	TORQUE (1)	POWER kW/SHP	
1	Zero Pressure Diff.	3.0k/10k	3.0k/10k	0	Not	Not Specified	1591	80%	Not	1527	80%	Not	-----
2	Zero Pressure Diff.	3.0k/10k	3.0k/10k	0	Speci-		1527	80%	Speci-	1591	80%	Specified	-----
3	Cabin Pressurized	3.0k/10k	Normal	Normal	fied		1527	80%	fied	1591	80%		-----
4	Cabin Pressurized	3.0k/10k	Normal	Normal			1591	80%		1527	80%		-----
5	Normal Cruise	4.6k/15k	0.7k/2.3k	36/5.2			1527	80%		1527	80%		-----
6	Normal Cruise	4.6k/15k	0.7k/2.3k	36/5.2			1527	80%		1527	80%		9 o'clock
7	Normal Cruise	4.6k/15k	0.7k/2.3k	36/5.2			1527	80%		1527	80%		11 o'clock
8	Normal Cruise	4.6k/15k	0.7k/2.3k	36/5.2			1527	80%		1527	80%		1 o'clock
9	Engines Diff.RPM	4.6k/15k	0.7k/2.3k	36/5.2			1591	80%		1527	80%		3 o'clock
10	Engines Diff.RPM	4.6k/15k	0.7k/2.3k	36/5.2			1527	80%		1591	80%		-----
11	Starboard Engine	4.6k/15k	0.7k/2.3k	36/5.2			0	0		1527	80%		-----
12	Port Engine	4.6k/15k	0.7k/2.3k	36/5.2			1527	80%		0	0		-----
13	Normal Cruise	9.1k/30k	2.6k/8.6k	43/6.3			1527	52%		1527	52%		9 o'clock
14	Normal Cruise	9.1k/30k	2.6k/8.6k	43/6.3			1527	52%		1527	52%		11 o'clock
15	Normal Cruise	9.1k/30k	2.6k/8.6k	43/6.3			1527	52%		1527	52%		1 o'clock
16	Normal Cruise	9.1k/30k	2.6k/8.6k	43/6.3			1527	52%		1527	52%		3 o'clock
17	Engines Diff.RPM	9.1k/30k	2.6k/8.6k	43/6.3			1591	52%		1527	52%		-----
18	Engines Diff.RPM	9.1k/30k	2.6k/8.6k	43/6.3			1527	52%		1591	52%		-----

(1) Torque measured as percentage of maximum

(2) Relative phase setting measured arbitrarily in terms of position of cockpit control knob

TABLE 2
FLIGHT TEST CONDITIONS: FLIGHT #1

CONDT IDENT.	REMARKS	FLIGHT PRESSURE ALTITUDE m/ft	CABIN ALTITUDE m/ft	CABIN PRESSURE DIFFER. kNm ⁻² /psi	IAS kts	OUTSIDE AIR TEMP °F	PROPELLER OPERATING CONDITION						RELATIVE PHASE SETTING (2)
							PORT			STARBOARD			
							RPM (3)	TORQUE (1)	POWER kW/SHP (4)	RPM (3)	TORQUE (1)	POWER kW/SHP (4)	
1	Zero Pressure Diff.	3.0k/10k	3.0k/10k	0/0	230	Not	1580	80	484/650	1525	80	468/627	—
2	Zero Pressure Diff.	3.0k/10k	3.0k/10k	0/0	230	Recorded	1525	80	468/627	1570	80	481/646	—
3	Cabin Pressurized	3.0k/10k	0.6k/2.1k	24/3.5	230		1528	80	469/628	1573	80	482/647	—
4	Cabin Pressurized	3.0k/10k	0.6k/2.1k	24/3.5	230		1573	80	482/647	1518	80	465/624	—
5	Normal Cruise	4.6k/15k	0.9k/3.0k	34/4.9	220		1533	80	470/630	1533	80	470/630	9 o'clock
6	Normal Cruise	4.6k/15k	0.9k/3.0k	34/4.9	220		1530	80	469/629	1530	80	469/629	11 o'clock
7	Normal Cruise	4.6k/15k	0.9k/3.0k	34/4.9	220		1530	80	469/629	1530	80	469/629	1 o'clock
8	Normal Cruise	4.6k/15k	0.9k/3.0k	34/4.9	220		1530	80	469/629	1530	80	469/629	3 o'clock
9	Engines Diff.RPM	4.6k/15k	0.9k/3.0k	34/4.9	220		1573	80	482/647	1520	80	466/625	—
10	Engines Diff.RPM	4.6k/15k	0.9k/3.0k	34/4.9	220		1525	80	468/627	1573	80	482/647	—
11	Starboard Engine	4.6k/15k	0.9k/3.0k	34/4.9	Not		0	0	0	1515	72	418/561	—
12	Port Engine	4.6k/15k	0.9k/3.0k	34/4.9	Record-		1520	80	466/625	0	0	0	—
13	Normal Cruise	8.5k/28k	2.4k/7.9k	43/6.2	ed		1528	Not		1528	Not		9 o'clock
14	Normal Cruise	8.5k/28k	2.4k/7.9k	43/6.2			1528	Recorded		1528	Recorded		11 o'clock
15	Normal Cruise	8.5k/28k	2.4k/7.9k	43/6.2			1528			1528			1 o'clock
16	Normal Cruise	8.5k/28k	2.4k/7.9k	43/6.2			1528			1528			3 o'clock
17	Engines Diff.RPM	8.5k/28k	2.4k/7.9k	43/6.2			1573			1518			—
18	Engines Diff.RPM	8.5k/28k	2.4k/7.9k	43/6.2			1523			1575			—

(1) Torque measured as percentage of maximum

(2) Relative phase setting measured arbitrarily in terms of position of cockpit control knob

(3) Based on frequency analysis of acoustic data

(4) Computed from rpm and torque

TABLE 3
FLIGHT TEST CONDITIONS: FLIGHT #2

CONDT IDENT.	REMARKS	FLIGHT PRESSURE ALTITUDE m/ft	CABIN ALTITUDE m/ft	CABIN PRESSURE DIFFER. kNm ⁻² /psi	IAS kts	OUTSIDE AIR TEMP °F	PROPELLER OPERATING CONDITION						RELATIVE PHASE SETTING (2)
							PORT			STARBOARD			
							RPM (3)	TORQUE (1)	POWER kW/SHP (4)	RPM (3)	TORQUE (1)	POWER kW/SHP (4)	
1	Zero Pressure Diff.	3.4k/11k	3.4k/11k	0/0	236	50	1573	82	494/663	1520	81	472/633	—
2	Zero Pressure Diff.	3.4k/11k	3.4k/11k	0/0	235	49	1525	80	468/627	1570	81	487/654	—
3	Cabin Pressurized	3.4k/11k	0.6k/2.1k	27/3.9	232	49	1525	80	468/627	1570	80	481/646	—
4	Cabin Pressurized	3.4k/11k	0.6k/2.1k	27/3.9	234	49	1573	76	458/614	1520	86	501/672	—
5	Normal Cruise	4.6k/15k	0.9k/2.8k	34/5.0	222	35	1530	80	469/629	1530	80	469/629	9 o'clock
6	Normal Cruise	4.6k/15k	0.9k/2.8k	34/5.0	226	35	1533	80	470/630	1533	80	470/630	11 o'clock
7	Normal Cruise	4.6k/15k	0.9k/2.8k	34/5.0	228	35	1530	80	469/629	1530	80	469/629	1 o'clock
8	Normal Cruise	4.6k/15k	0.9k/2.8k	34/5.0	228	35	1530	80	469/629	1530	80	469/629	3 o'clock
9	Engines Diff.RPM	4.6k/15k	0.9k/2.8k	34/5.0	227	34	1575	80	483/648	1520	76	466/625	—
10	Engines Diff.RPM	4.6k/15k	0.9k/2.8k	34/5.0	229	34	1525	86	503/674	1570	76	457/613	—
11	Starboard Engine	4.6k/15k	0.9k/2.8k	34/5.0	170	30	0	0	0	1515	76	441/592	—
12	Port Engine	4.6k/15k	0.9k/2.8k	34/5.0	170	30	1520	80	466/625	0	0	0	—
13	Normal Cruise	8.8k/29k	2.4k/7.9k	44/6.4	168	-23	1538	53	312/419	1538	53	312/419	9 o'clock
14	Normal Cruise	8.8k/29k	2.4k/7.9k	44/6.4	168	-23	1538	54	318/427	1538	54	318/427	11 o'clock
15	Normal Cruise	8.8k/29k	2.4k/7.9k	44/6.4	174	-23	1538	54	318/427	1538	54	318/427	1 o'clock
16	Normal Cruise	8.8k/29k	2.4k/7.9k	44/6.4	175	-23	1540	54	318/427	1540	54	318/427	3 o'clock
17	Engines Diff.RPM	8.8k/29k	2.4k/7.9k	44/6.4	173	-23	1570	52	313/420	1518	52	303/406	—
18	Engines Diff.RPM	8.8k/29k	2.4k/7.9k	44/6.4	174	-23	1523	49	286/384	1573	56	337/452	—

- (1) Torque measured as percentage of maximum
- (2) Relative phase setting measured arbitrarily in terms of position of cockpit control knob
- (3) Based on frequency analysis of acoustic data
- (4) Computed from rpm and torque

TABLE 4
FLIGHT TEST CONDITIONS: FLIGHT #3

CONDY IDENT.	REMARKS	FLIGHT PRESSURE ALTITUDE m/ft	CABIN ALTITUDE m/ft	CABIN PRESSURE DIFFER. kNm ⁻² /psi	IAS kts	OUTSIDE AIR TEMP °F	PROPELLER OPERATING CONDITION						RELATIVE PHASE SETTING (2)
							PORT			STARBOARD			
							RPM (3)	TORQUE (1)	POWER kW/SHP (4)	RPM (3)	TORQUE (1)	POWER kW/SHP (4)	
1	Zero Pressure Diff.	3.0k/10k	3.0k/10k	0/0	233	53	1573	80	482/647	1520	80	466/625	—
2	Zero Pressure Diff.	3.0k/10k	3.0k/10k	0/0	233	53	1525	80	468/627	1573	81	488/655	—
3	Cabin Pressurized	3.0k/10k	0.5k/1.7k	26/3.7	230	53	1525	78	456/611	1570	74	445/597	—
4	Cabin Pressurized	3.0k/10k	0.5k/1.7k	26/3.7	230	53	1573	80	482/647	1518	81	471/632	—
5	Normal Cruise	4.3k/14k	0.6k/2.1k	34/5.0	220	38	1530	81	475/637	1530	82	481/645	9 o'clock
6	Normal Cruise	4.3k/14k	0.6k/2.1k	34/5.0	227	38	1533	82	482/646	1533	83	488/654	11 o'clock
7	Normal Cruise	4.3k/14k	0.6k/2.1k	34/5.0	230	38	1530	82	481/645	1530	83	487/653	1 o'clock
8	Normal Cruise	4.3k/14k	0.6k/2.1k	34/5.0	230	38	1530	82	481/645	1530	83	487/653	3 o'clock
9	Engines Diff.RPM	4.3k/14k	0.6k/2.1k	34/5.0	233	39	1573	80	482/647	1520	80	466/625	—
10	Engines Diff.RPM	4.3k/14k	0.6k/2.1k	34/5.0	230	39	1525	80	468/627	1573	80	482/647	—
11	Starboard Engine	4.3k/14k	0.6k/2.1k	34/5.0	183	38	0	0	0	1515	77	447/600	—
12	Port Engine	4.3k/14k	0.6k/2.1k	34/5.0	173	38	1520	79	460/617	0	0	0	—
13	Normal Cruise	8.5k/28k	2.3k/7.4k	44/6.4	170	-19	1525	53	310/415	1525	53	310/415	9 o'clock
14	Normal Cruise	8.5k/28k	2.3k/7.4k	44/6.4	174	-19	1528	53	310/416	1528	53	310/416	11 o'clock
15	Normal Cruise	8.5k/28k	2.3k/7.4k	44/6.4	173	-19	1528	53	310/416	1528	53	310/416	1 o'clock
16	Normal Cruise	8.5k/28k	2.3k/7.4k	44/6.4	173	-19	1528	53	310/416	1528	53	310/416	3 o'clock
17	Engines Diff.RPM	8.5k/28k	2.3k/7.4k	44/6.4	175	-19	1570	53	319/428	1518	53	308/414	—
18	Engines Diff.RPM	8.5k/28k	2.3k/7.4k	44/6.4	174	-19	1520	51	297/398	1570	52	313/420	—

(1) Torque measured as percentage of maximum

(2) Relative phase setting measured arbitrarily in terms of position of cockpit control knob

(3) Based on frequency analysis of acoustic data

(4) Computed from rpm and torque

TABLE 5
FLIGHT TEST CONDITIONS: FLIGHT #4

CONDT IDENT.	REMARKS	FLIGHT PRESSURE ALTITUDE m/ft	CABIN ALTITUDE m/ft	CABIN PRESSURE DIFFER. kNm ⁻² /psi	IAS kts	OUTSIDE AIR TEMP °F	PROPELLER OPERATING CONDITION						RELATIVE PHASE SETTING (2)
							PORT			STARBOARD			
							RPM (3)	TORQUE (1)	POWER kW/SHP (4)	RPM (3)	TORQUE (1)	POWER kW/SHP (4)	
1	Zero Pressure Diff.	3.4k/11k	3.4k/11k	0/0	228	46	1575	80	483/648	1520	80	466/625	---
2	Zero Pressure Diff.	3.4k/11k	3.4k/11k	0/0	234	46	1525	80	468/627	1570	81	487/654	---
3	Cabin Pressurized	3.4k/11k	0.6k/2.1k	27/3.9	235	46	1528	80	468/628	1573	82	494/663	---
4	Cabin Pressurized	3.4k/11k	0.6k/2.1k	27/3.9	236	46	1573	80	482/647	1518	81	471/632	---
5	Normal Cruise	---	---	---	---	---	---	---	---	---	---	---	---
6	Normal Cruise	---	---	---	---	---	---	---	---	---	---	---	---
7	Normal Cruise	---	---	---	---	---	---	---	---	---	---	---	---
8	Normal Cruise	---	---	---	---	---	---	---	---	---	---	---	---
9	Engines Diff.RPM	4.6k/15k	0.8k/2.6k	35/5.1	221	32	1575	80	483/648	1530	80	469/629	---
10	Engines Diff.RPM	4.6k/15k	0.8k/2.6k	35/5.1	230	32	1528	80	469/628	1573	82	494/663	---
11	Starboard Engine	4.6k/15k	0.8k/2.6k	35/5.1	188	32	0	0	0	1515	76	441/592	---
12	Port Engine	4.6k/15k	0.8k/2.6k	35/5.1	174	32	1520	78	454/609	0	0	0	---
13	Normal Cruise	8.5k/28k	2.3k/7.6k	43/6.3	166	-16	1520	54	315/422	1520	54	315/422	---
14	Normal Cruise	---	---	---	---	---	---	---	---	---	---	---	---
15	Normal Cruise	---	---	---	---	---	---	---	---	---	---	---	---
16	Normal Cruise	---	---	---	---	---	---	---	---	---	---	---	---
17	Engines Diff.RPM	8.5k/28k	2.3k/7.6k	43/6.3	172	-16	1570	52	313/420	1518	52	303/406	---
18	Engines Diff.RPM	8.5k/28k	2.3k/7.6k	43/6.3	170	-16	1523	53	309/415	1573	52	314/420	---

- (1) Torque measured as percentage of maximum
(2) Phase control inoperative during Flight #4.
(3) Based on frequency analysis of acoustic data
(4) Computed from rpm and torque

Three nominal flight altitudes were selected for the test condition, 3,000 m (10,000 ft), 4600 m (15,000 ft), and 9100 m (30,000 ft). The 3,000 m altitude was chosen as a suitable altitude for tests at zero cabin pressure differential; the two higher altitudes were chosen to be similar to those of earlier test series [9, 19], with 9200 m being a typical cruise altitude. The actual values of flight altitude for any given test depended upon aircraft traffic control constraints at the time of the test.

Propeller torque settings were selected to be typical cruise conditions--they were also similar to conditions selected in earlier tests. Propeller rotational speeds were restricted to the range (96% to 100%) permitted for the TPE331 engines. Actual values for the torque were read from cockpit instruments; propeller rpm values were deduced from measured propeller blade passage frequencies in the acoustic spectra.

The instruments in the cockpit of the test airplane did not permit selection of specific relative phase angles between the two propellers. Adjustment of the relative phase was provided simply by means of a knob without a scale. Consequently, four arbitrary settings were chosen whereby the knob position was identified as 9 o'clock, 11 o'clock, 1 o'clock, and 3 o'clock. The full range of adjustment for the knob was from 8 o'clock to 4 o'clock. Analysis of the test data was used to provide an indication of the associated relative phase angles. (This analysis is discussed later in the report). It is understood that the synchrophaser operates with the starboard propeller as the slave of the port propeller.

In an attempt to overcome the uncertainty regarding the relative phase setting, measurements were performed also when the two propellers were operated at different rotational speeds, but at the

same torque. The objective of the tests was to separate the contributions from the two engines so that constructive or destructive acoustic interference, which occurs in the cabin when both propellers operate at the same speed, could be prevented. The propeller speeds were selected to be the maximum (100%) and minimum (96%) values permitted by the engine design. Propeller torque was used as a controlling parameter rather than engine power because only torque is indicated in the cockpit. As a consequence, the engines were at slightly different power settings, as can be seen in Tables 2 through 5.

Outside air temperature was measured by means of cockpit instrumentation. In addition, the cabin skin temperature was measured on the fourth flight when the fiberglass batts were installed. Values of the skin temperature are given in Table 6. There are some small differences between the outside air and skin temperatures, but these are probably calibration errors. In general, the results show that the skin temperature is approximately equal to the outside air temperature, after allowing for a short adjustment period.

All acoustic data were recorded during straight-and-level flight. Flight through clouds was avoided and the flight conditions were essentially "smooth" throughout the four flight tests. Four crew members were present during each flight. They consisted of the pilot, flight engineer (in copilot's seat) and two acoustic test engineers seated in chairs close to microphone locations 2 and 3.

2.3 Instrumentation

During the flight test program measurements were made of the sound pressure levels inside the cabin and the fluctuating pressures on

TABLE 6

FUSELAGE SKIN TEMPERATURE MEASURED DURING FLIGHT #4

Condt. Ident.	Time Hrs	Flight Altitude m/ft	Outside Air Temp °F	Skin Temperature °F
Ground	1420	---	--	92
1	1448	3.4k/11k	46	52
3	1502	3.4k/11k	46	50
9	1511	4.6k/15k	32	35
10	1518	4.6k/15k	32	36
12	1537	4.6k/15k	32	30
17	1544	8.5k/28k	-16	-19
17	1547	8.5k/28k	-16	-20
18	1550	8.5k/28k	-16	-22
Ground	1620	---	82	75

the exterior of the fuselage. Six fixed microphone locations were selected inside the cabin. These locations are shown in Figure 4 and listed in Table 7. Photographs of some of the installed microphones are shown in Figure 5. The locations were selected to be similar to those used in earlier tests [9, 19]. Four of the locations were on the starboard side of the cabin and two on the port; all six microphones were positioned vertically at the approximate ear level of a seated passenger. The microphones were not moved until the end of flight #3 when they were removed to allow for installation of the fiberglass treatment. The microphones were then reinstalled for the fourth flight.

Exterior fluctuating pressures were measured simultaneously on the port and starboard sides of the fuselage using two condenser microphones mounted without protective grids and with diaphragms flush with the exterior surface of the skin panels, and two stick-on pressure sensors. The locations are shown in Figure 4 and listed in Table 8. Based on available drawings, it is estimated that the flush-mounted microphones were about 5 cm (2 inches) below the centers of the propeller spinners. Close-up views of the installations are shown in Figure 6. Because of problems encountered with data from the pressure sensors, only data from the flush-mounted microphones are presented in this report.

The microphones used inside the cabin were Bruel and Kjaer Type 4155 0.5-inch prepolarized condenser microphones with windscreens. The exterior flush-mounted microphones were B & K Type 4135 (port side) or Type 4136 (starboard side), installed by means of B & K Type UA 0122 Flexible Adaptors with flush mountings. The stick-on pressure sensors were BBN Model 376 pressure sensors. All the data were recorded simultaneously on a 14-track Honeywell Model 5600C tape recorder at a tape speed of 30 ips using FM record/reproduce and IRIG Intermediate band (10 kHz bandwidth).

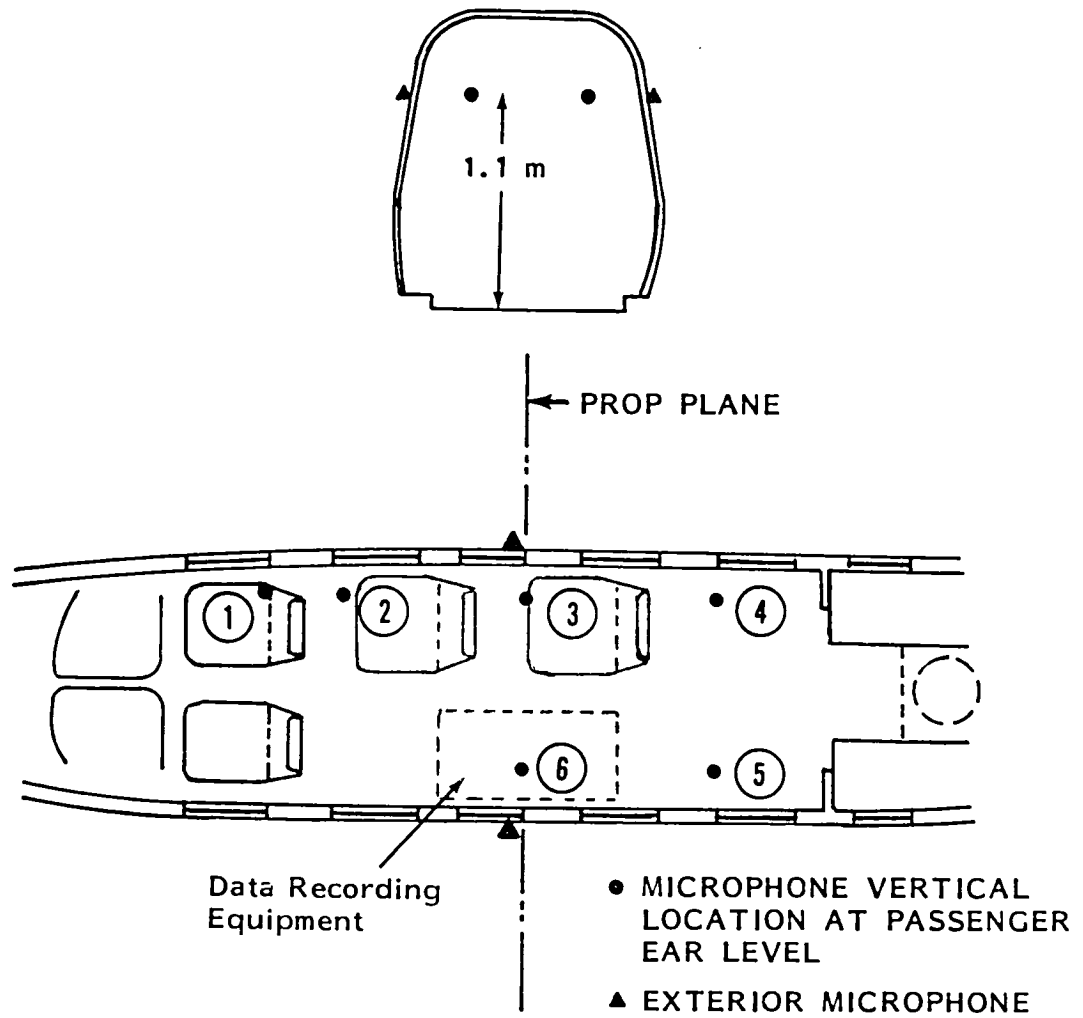

FIGURE 4. LOCATIONS OF MICROPHONES INSIDE CABIN AND ON EXTERIOR OF FUSELAGE.

TABLE 7
LOCATIONS OF CABIN MICROPHONES

Transducer	Location*	Station (Inches)
1	Copilot seat	60
2	Forward Passenger seat, starboard	78
3	Propeller plane, starboard	117
4	Aft passenger seat, starboard	155
5	Aft passenger seat, port	155
6	Propeller plane, port	117

*All microphones at approximate ear height of a seated passenger. Seats were present for the test program at locations 1, 2, and 3 only. Location 6 was above the test instrumentation.

TABLE 8
LOCATIONS OF TRANSDUCERS ON FUSELAGE EXTERIOR

Transducer	Location	Station (inches)	Waterline (inches)
Flush Microphone Port	7.5 cm (3 in.) forward of propeller plane	114.5	-11
Starboard	7.5 cm (3 in.) forward of propeller plane	114.5	-11
Pressure Sensor Port	1.3 cm (0.5 in.) aft of propeller plane	117.5	-12
Starboard	2.8 cm (1.5 in.) aft of propeller plane	118.5	-12

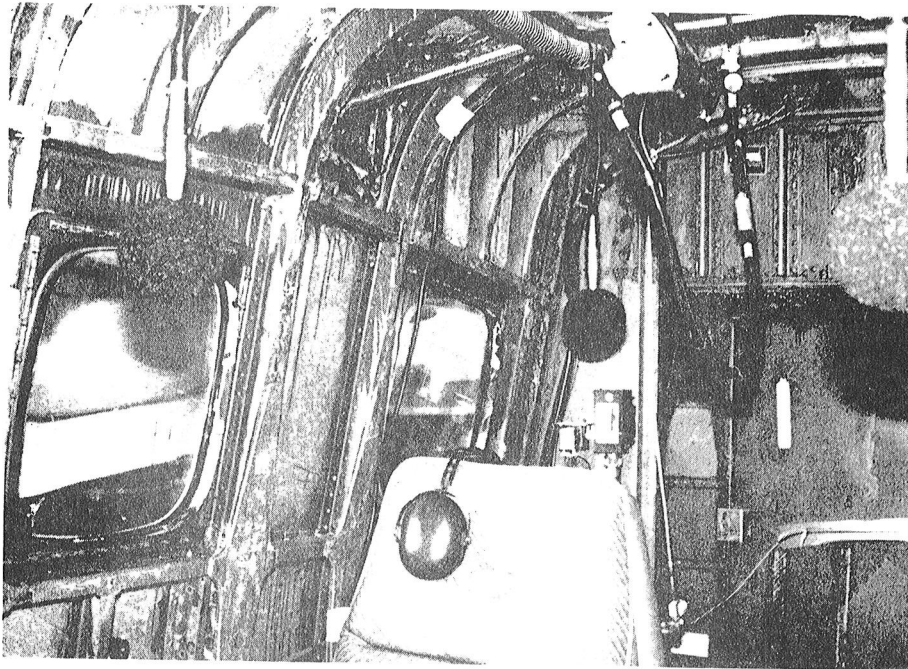

(a) Starboard Side of Cabin

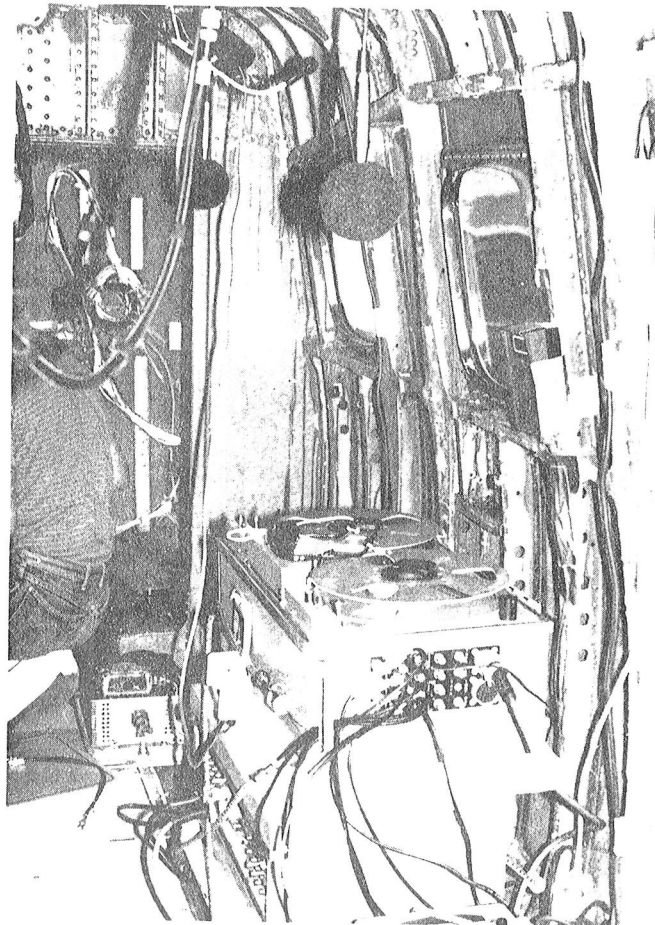

(b) Port Side of Cabin

FIGURE 5. INTERIOR OF BARE CABIN SHOWING INSTALLED INSTRUMENTAION

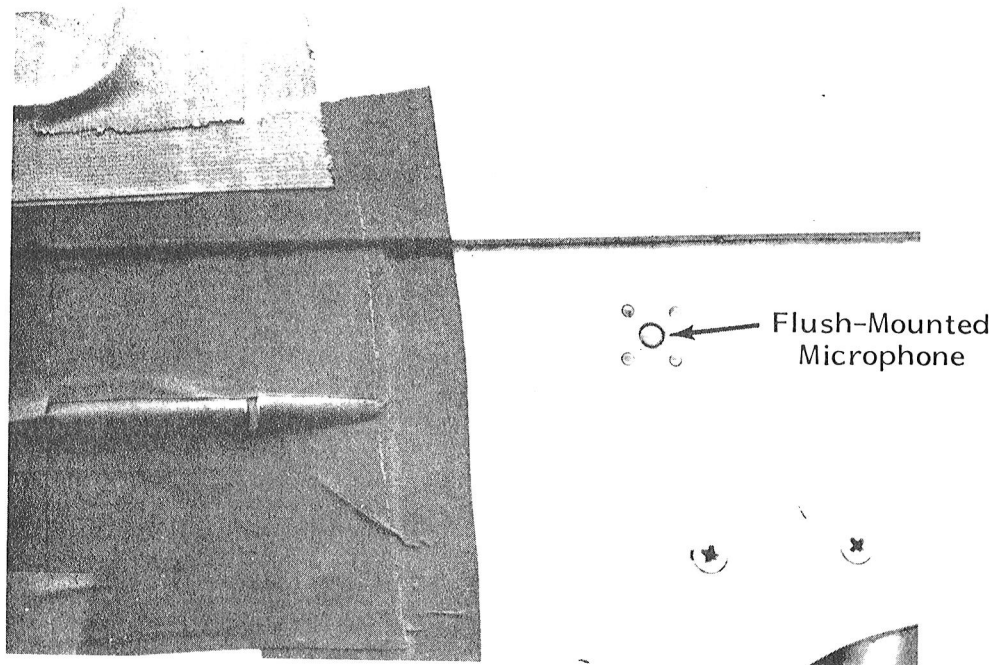

(a) Starboard Side of Fuselage

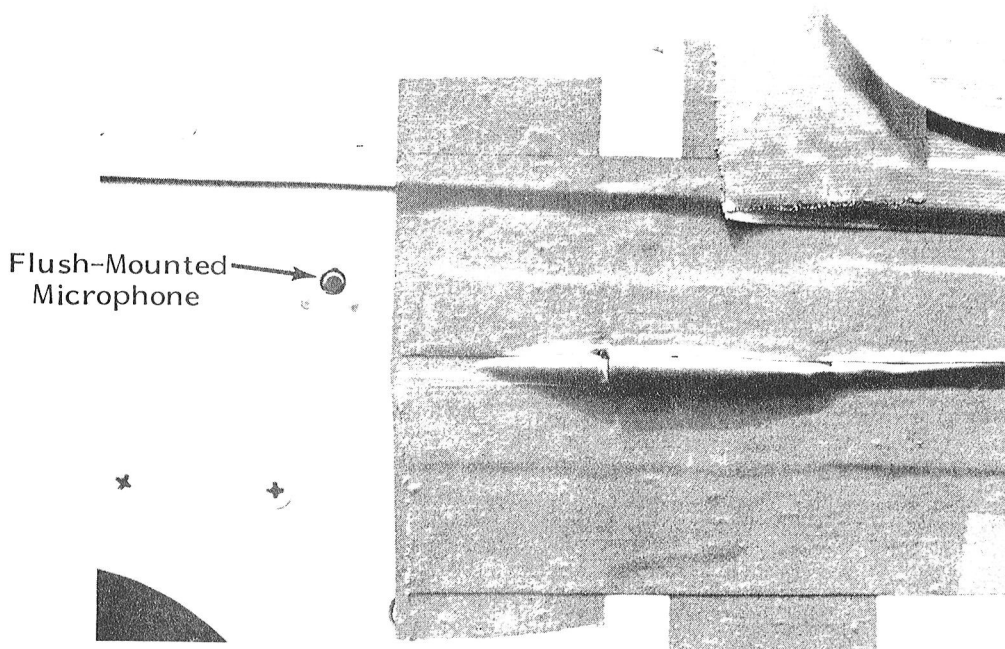

(b) Port Side of Fuselage

FIGURE 6. EXTERNAL MICROPHONES AND PRESSURE SENSORS

Data reduction was performed in terms of narrowband spectra using a Spectral Dynamics Model 360 Digital Signal Processor and in terms of one-third octave band spectra using a GenRad Type 1921 one-third octave band analyzer. In order to provide adequate resolution for the low-order harmonics of the blade passage frequency, the narrowband data reduction was performed first for the frequency range 0-500 Hz and then repeated for the range 0-1000 Hz. Harmonic levels were obtained for the lower frequency range and spectra plotted for the higher range. Where necessary, harmonic levels were adjusted to remove the estimated broadband contribution at the harmonic frequencies.

2.4 Interior Configuration

The first three flight tests were conducted with a "bare" or untreated interior. All acoustic and thermal treatments (fiberglass, interior trim, carpets, bulkhead covering, etc.) were removed from the interior aft of Station 60.5, i.e. aft of the pilot and copilot seats. Also, all dynamic absorbers, which are installed in production aircraft [20] and tuned to the first (fundamental) and second harmonics of the propeller blade passage frequency, were removed. These absorbers were present in the previous flight test series [9, 19]. Four seats were installed in the interior for all four flights. Three of the seats were close to microphone locations, as is indicated in Figure 4.

Prior to the fourth flight, fiberglass batts were installed throughout the cabin aft of Station 60.5. The batts were formed from Manville "Insul-Shield" Type 3 which has a density of 48 kg/cu.m (3 pcf). The material was unfaced and had a thickness of 5 cm (2 inches) on the sidewalls and 7.5 cm (3 inches) on the cabin aft bulkhead. "Insul-Shield" consists of inorganic glass fibers bonded with a thermosetting resin. It was selected for the

present test series because batts, cut to size, were immediately available from a laboratory test rig at Gulfstream Aerospace Corp. The objective was to add acoustic absorption to the interior volume.

The narrow regions which surround cabin windows were not amenable to treatment with Insul-Shield. In these cases, a treatment of AA fiberglass with a thickness of 5 cm (2 inches) was used. There was no sound-absorbing material on the cabin floor.

Sample batts of "Insul-Shield" material are shown in Figure 7(a), and a sample fiberglass treatment to surround a window is shown in Figure 7(b). Installed treatments are shown in Figure 8.

In addition, an acoustic barrier was installed between the cockpit and the cabin. This barrier consisted of TNB-101 PSA Barrier and a 2.5 cm (1 inch) thick sheet of open-cell foam. The TNB-101 material was composed of a sheet of lead-impregnated vinyl which was 0.25 cm (0.1 inch) thick and a layer of foam which was 0.64 cm (0.25 inch) thick. The outer face of the foam layer had an adhesive surface which was used to attach the 2.5 cm sheet of open-cell foam. The surface density of the TNB-101 PSA Barrier was 4.94 kg/sq.m (1.01 psf), as measured by Gulfstream Aerospace.

The barrier was attached by cable ties to a horizontal crossbar which was installed just aft of Station 69. The top edge of the barrier was attached by ties to the fuselage frame at that station. The fit between the barrier and fuselage structure was not tight because of the presence of ducts, cables, etc., and small gaps were observed during flight #4. However, time constraints did not permit improvements to the installation.

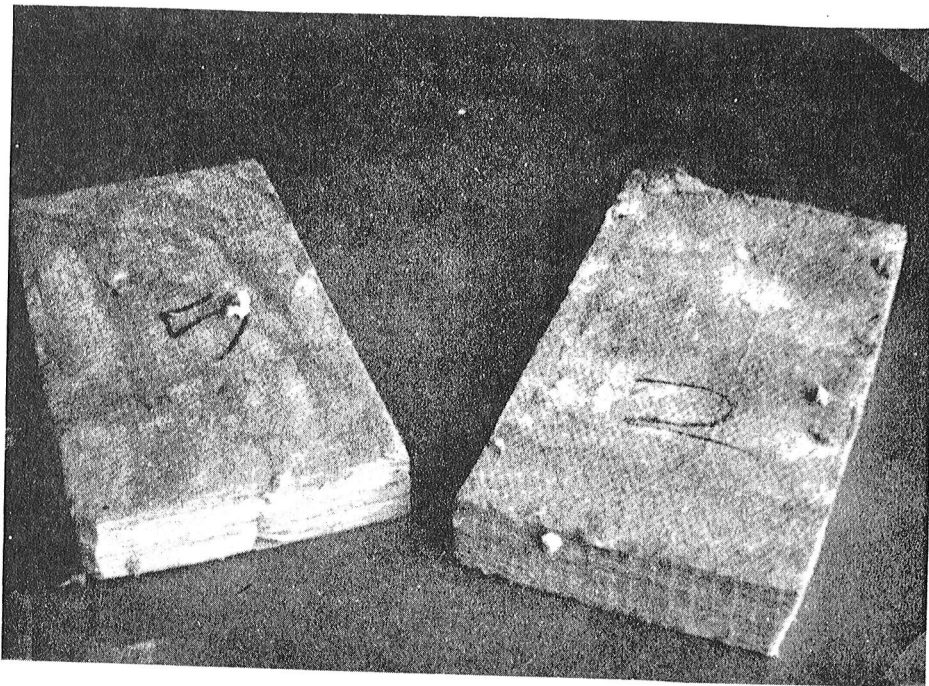

(a) Insul-Shield Batts

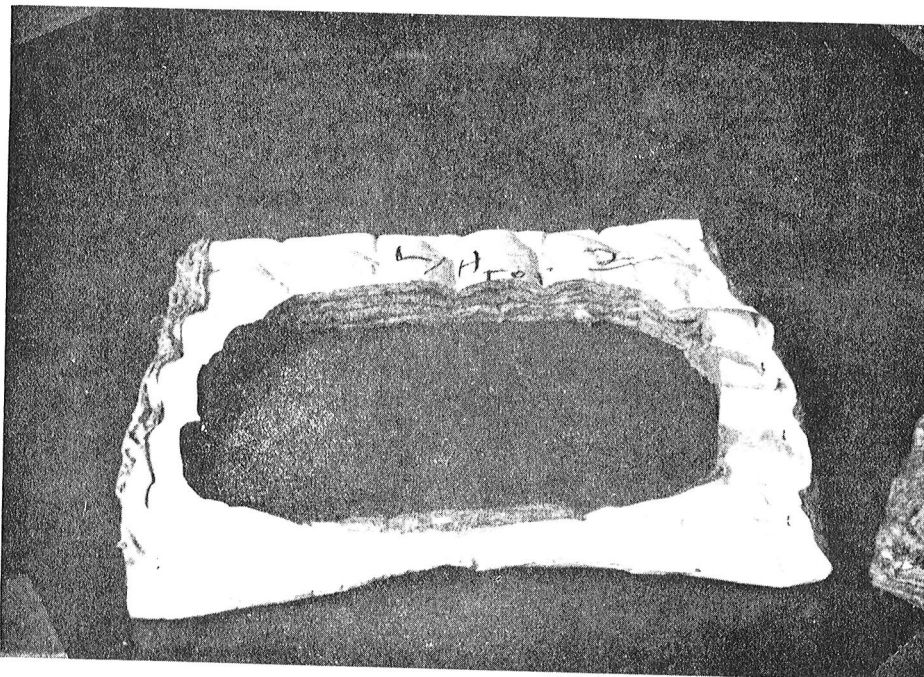

(b) Window-Surround Treatment

FIGURE 7. SAMPLES OF SOUND-ABSORBING TREATMENTS

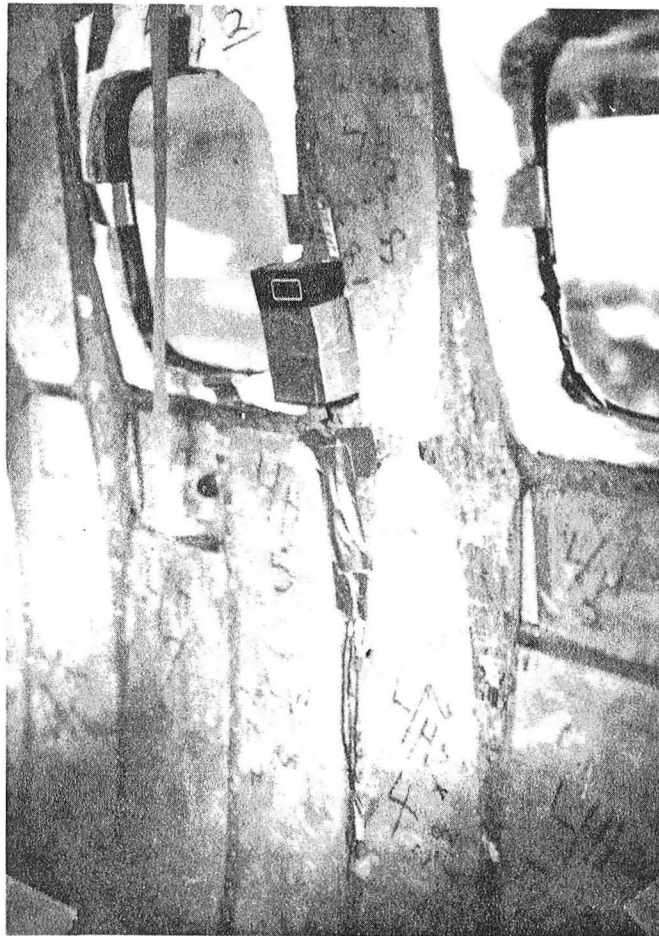

FIGURE 8. SOUND-ABSORBING MATERIAL INSTALLED IN CABIN

Furthermore, the acoustic leaks were probably insignificant since the acoustic treatment in the cabin did not provide a high transmission loss through the fuselage sidewall. The barrier was cut vertically at the mid-point to allow access to the cockpit; an adequate overlap of material at this cut prevented an acoustic leak. The barrier was installed such that the foam sheet was on the cabin side of the bulkhead.

3.0 EXTERIOR FLUCTUATING PRESSURE FIELD

3.1 Narrowband Spectra

Typical narrowband spectra for the exterior fluctuating pressure field are given in Figures 9 through 12. The data are associated with flight #3 for conditions under which the two propellers were operated at different rotational speeds, or under single-engine operation. The spectra are presented for the frequency range 0-1000 Hz, but the plotted sound levels at frequencies above 800 Hz are attenuated by the anti-aliasing filters of the analyzer.

The spectra consist of a fairly uniform broadband level on which is superimposed a series of discrete frequency components associated with harmonics of the propeller blade passage frequency. The higher order harmonics are seen most strongly at the highest flight altitude, which for this particular flight was 8,500 m or 28,000 ft (nominally 9,100 m or 30,000 ft). Since the propellers were operating at different rotational speeds, their individual contributions can be identified in the figures, except for the fundamentals which merge together for this particular frequency resolution. Relative magnitudes of the fundamental component can be compared, however, in Figures 11 and 12 which contain data for single-engine operation. It is seen that, at a given location, the sound levels generated by the adjacent propeller are 15 to 25 dB higher than the levels associated with the propeller on the opposite side of the airplane. Harmonic sound pressure levels for the port and starboard propeller are tabulated in Appendix A for all four flights.

In some spectra, secondary peaks can be seen at harmonics of the propeller shaft rotational frequency and at the fundamental rotational frequency of the engine turbine shaft. Propeller shaft

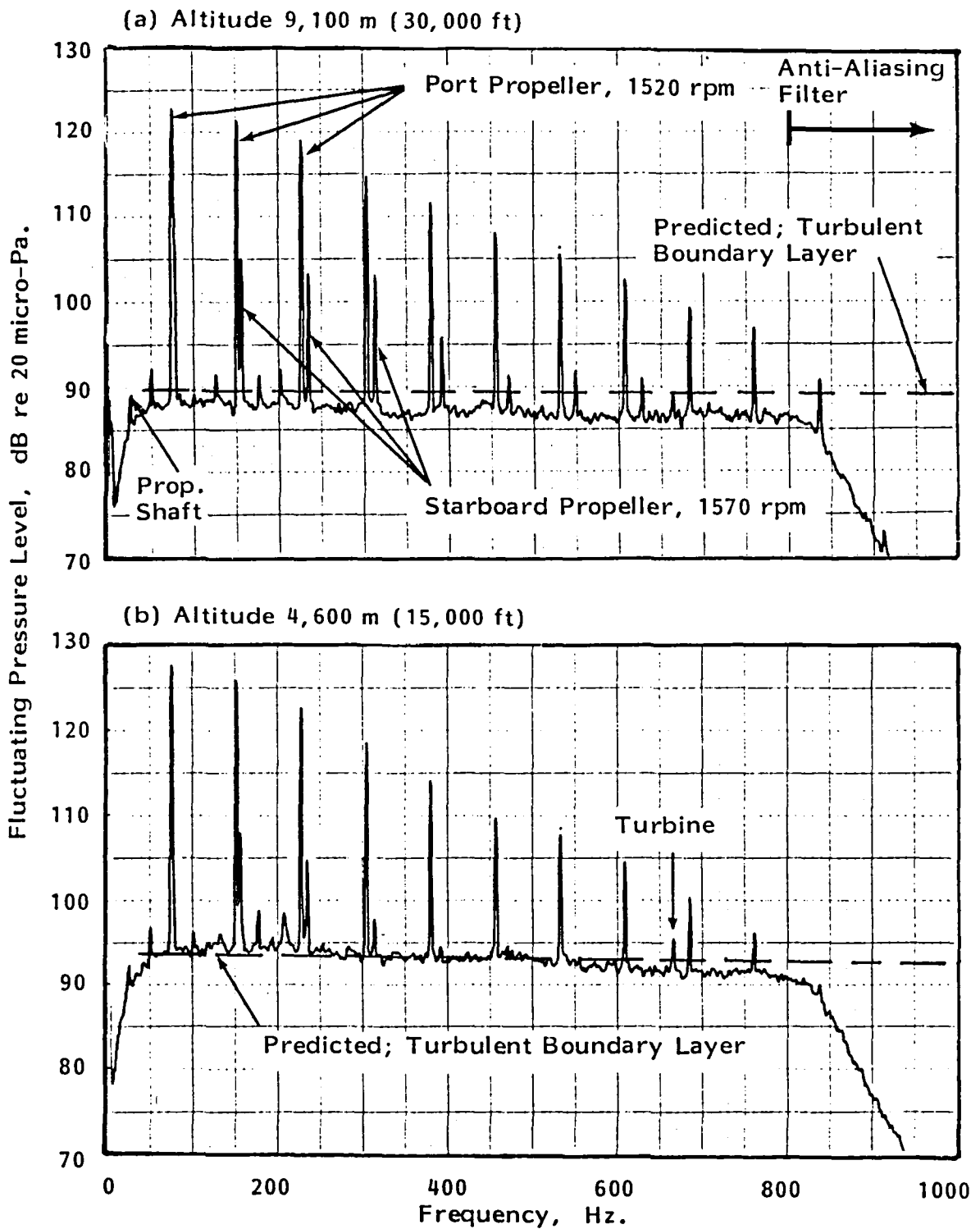

FIGURE 9. NARROWBAND SPECTRA OF EXTERNAL FLUCTUATING PRESSURE FIELD MEASURED ON PORT SIDE OF FUSELAGE. (PROPELLERS OPERATING AT DIFFERENT RPM)

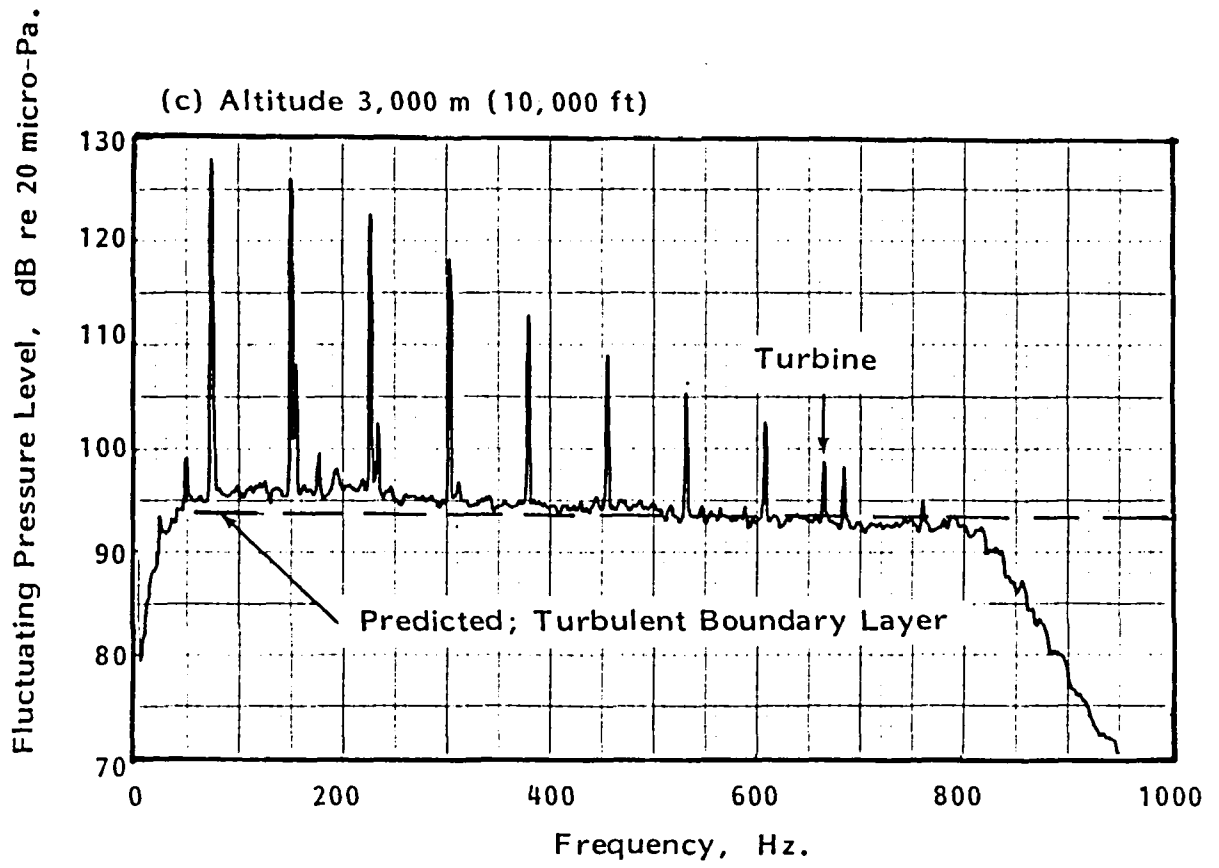

FIGURE 9. CONTINUED

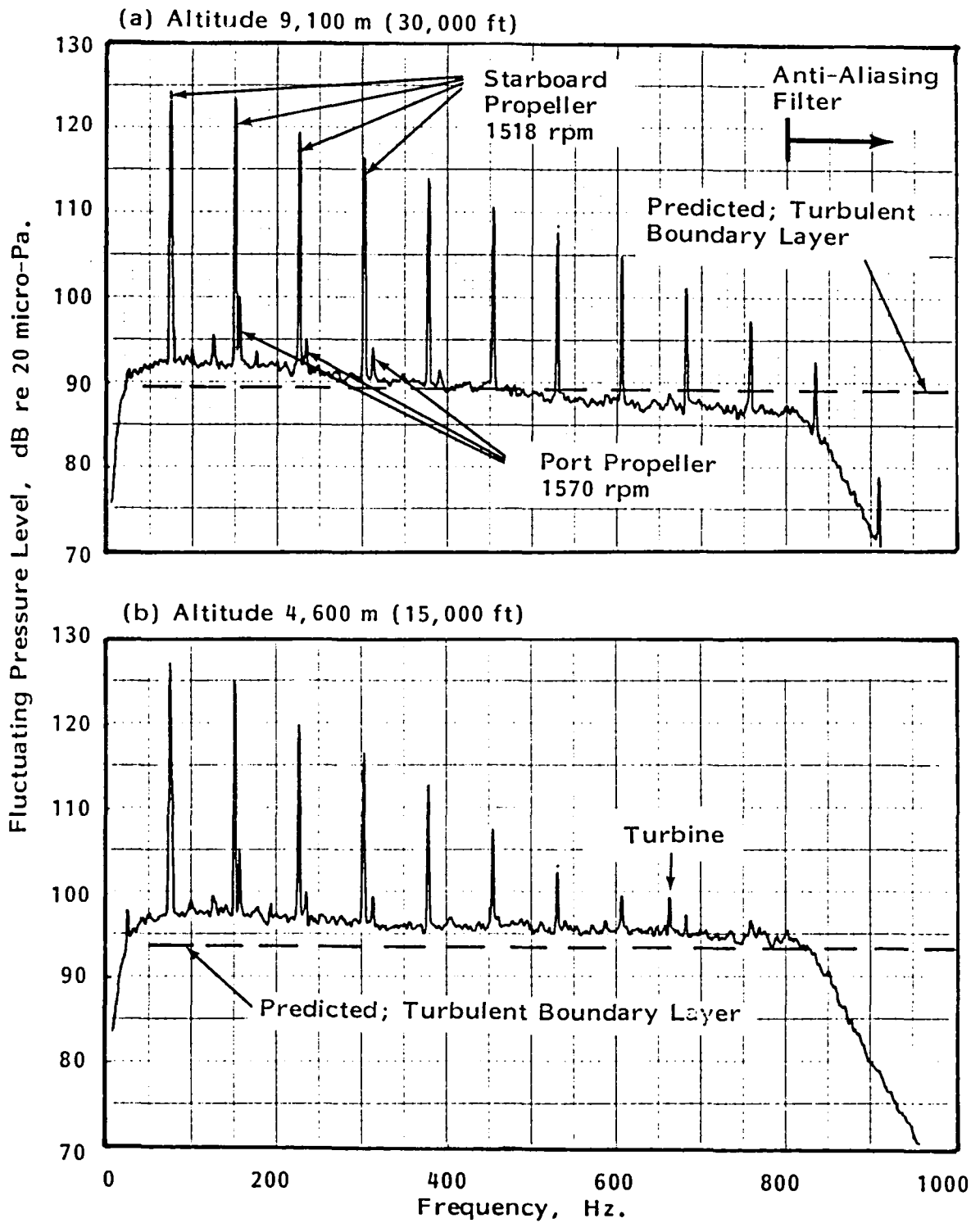

FIGURE 10. NARROWBAND SPECTRA OF EXTERNAL FLUCTUATING PRESSURE FIELD MEASURED ON STARBOARD SIDE OF FUSELAGE. (PROPELLERS OPERATING AT DIFFERENT RPM)

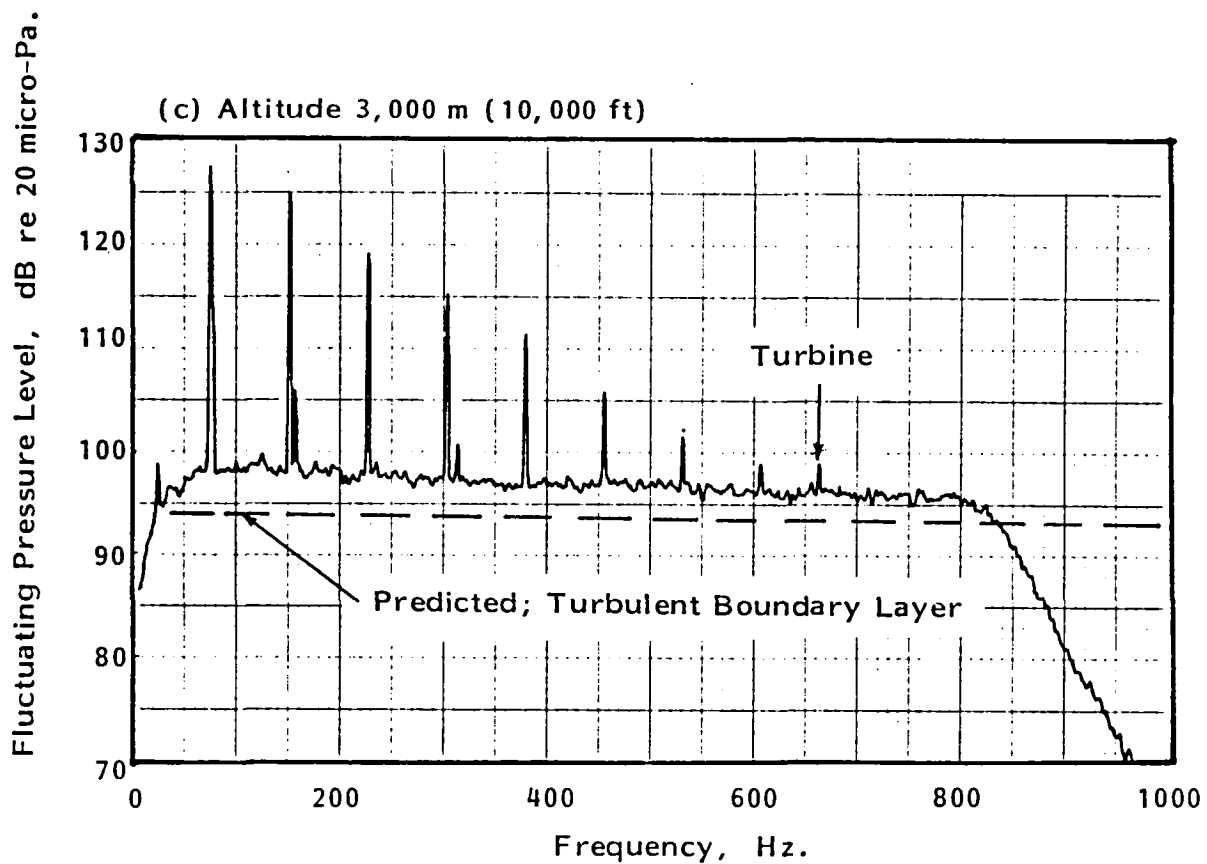

FIGURE 10. CONTINUED

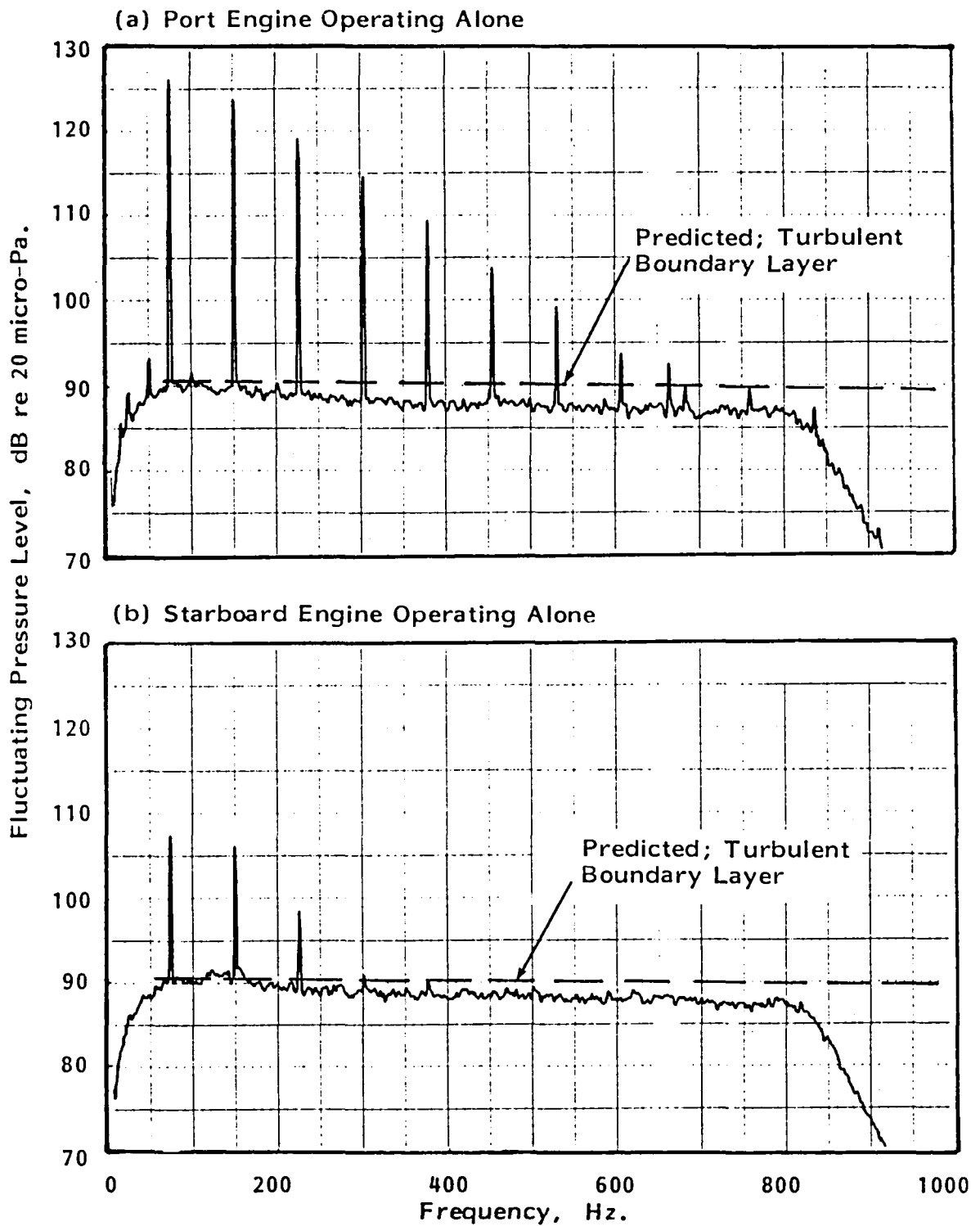

FIGURE 11. NARROWBAND SPECTRA OF EXTERNAL FLUCTUATING PRESSURE FIELD MEASURED ON PORT SIDE OF FUSELAGE DURING SINGLE-ENGINE OPERATION

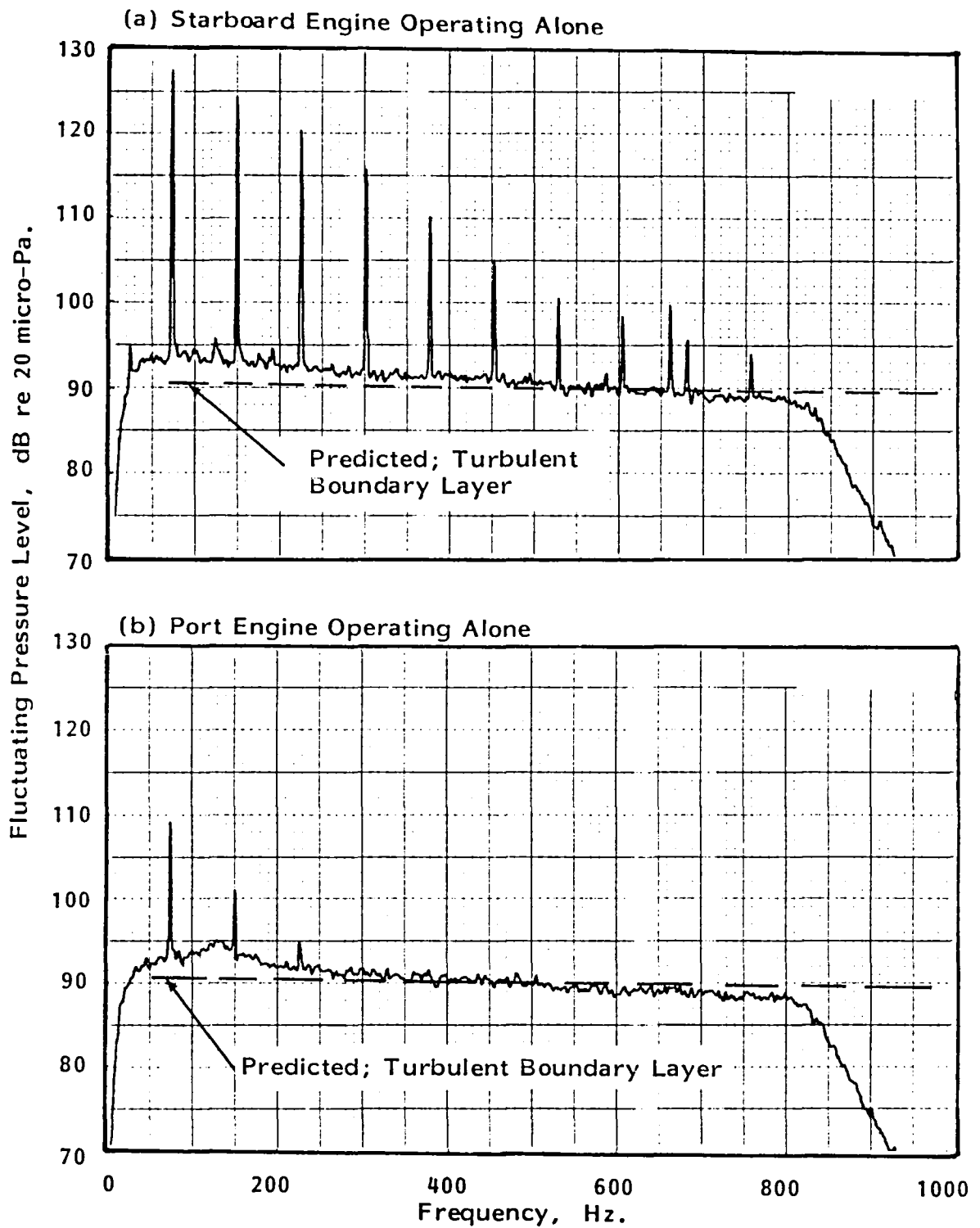

FIGURE 12. NARROWBAND SPECTRA OF EXTERNAL FLUCTUATING PRESSURE FIELD MEASURED ON STARBOARD SIDE OF FUSELAGE DURING SINGLE-ENGINE OPERATION

harmonics are more evident in data measured on the port side than on the starboard side. The components may be associated with a slight difference between different blades of the propeller. On the other hand, both the propeller shaft and engine turbine contributions may result from structureborne noise transmission via the engine mounts.

The broadband levels in the spectra appear to vary with aircraft speed. For example, when spectra measured at the starboard location at an altitude of 4,600 m are compared for two- and one-engine operation (Figures 10(b) and 12(a)) it is seen that the broadband levels differ by 4 to 5 dB. The lower levels are associated with the lower aircraft speeds during single-engine operation. These broadband levels can be attributed to the fluctuating pressure field of the turbulent boundary layer, as is discussed later.

3.2 Harmonic Data Variability

One important objective of the flight test program was the investigation of data variability for harmonic levels associated with the propeller noise. For this reason, three similar flights were performed for the untreated cabin configuration, then a fourth flight was conducted with a partially treated interior. Since there were no changes to the external configuration of the airplane, data from all four flights could be considered together. However, data from flight #4 will be considered separately, in order to assist in evaluating the effect of the fiberglass treatment on the cabin sound levels.

For this analysis data measured by a given flush-mounted microphone were investigated with regard to the sound levels generated by the propeller adjacent to that microphone. It has been

shown earlier that, when propellers are operating at different rpm, the harmonic levels on one side of the fuselage are dominated by the propeller on that side of the airplane. Thus, it can be assumed that, when two propellers are operating at the same rpm, the sound levels measured by a given flush-mounted microphone are dominated by the adjacent propeller. Under this assumption, it is possible to obtain five test points for low propeller rpm conditions at 4600 m (15000 ft) and five points at 9100 m (30,000 ft) nominal altitudes (except for flight #4 when there was a malfunction of the synchrophaser). Flight test conditions for single- and twin-engine operation were sufficiently different that single-engine operation data for 4600 m altitude were excluded from the data set. One test point for high rpm conditions was available for 4600 m and 9100 m altitudes from each flight. For the 3000 m (10,000 ft) altitude operation two test points were available for both low and high rpm operation.

The ranges of harmonic levels for each test condition and each side of the fuselage are shown in Figures 13 through 16. The figures show the upper and lower bounds for the harmonic levels, irrespective of flight and test conditions for the first three flights. Inspection of the data shows that the variability of harmonic level for the starboard propeller is generally less than that for the port propeller. When averaged over all harmonics and all test conditions the harmonic level average variability or data range was 3 dB (or ± 1.5 dB) at the starboard measurement location and 5 dB (or ± 2.5 dB) at the port location. Data from flight #4 are superimposed on the data ranges for flights 1 through 3. It is seen that, in general, data from flight #4 are within the range for the preceding flights, although in some cases they lie at, or close to, the upper bound. This is true particularly of the port propeller.

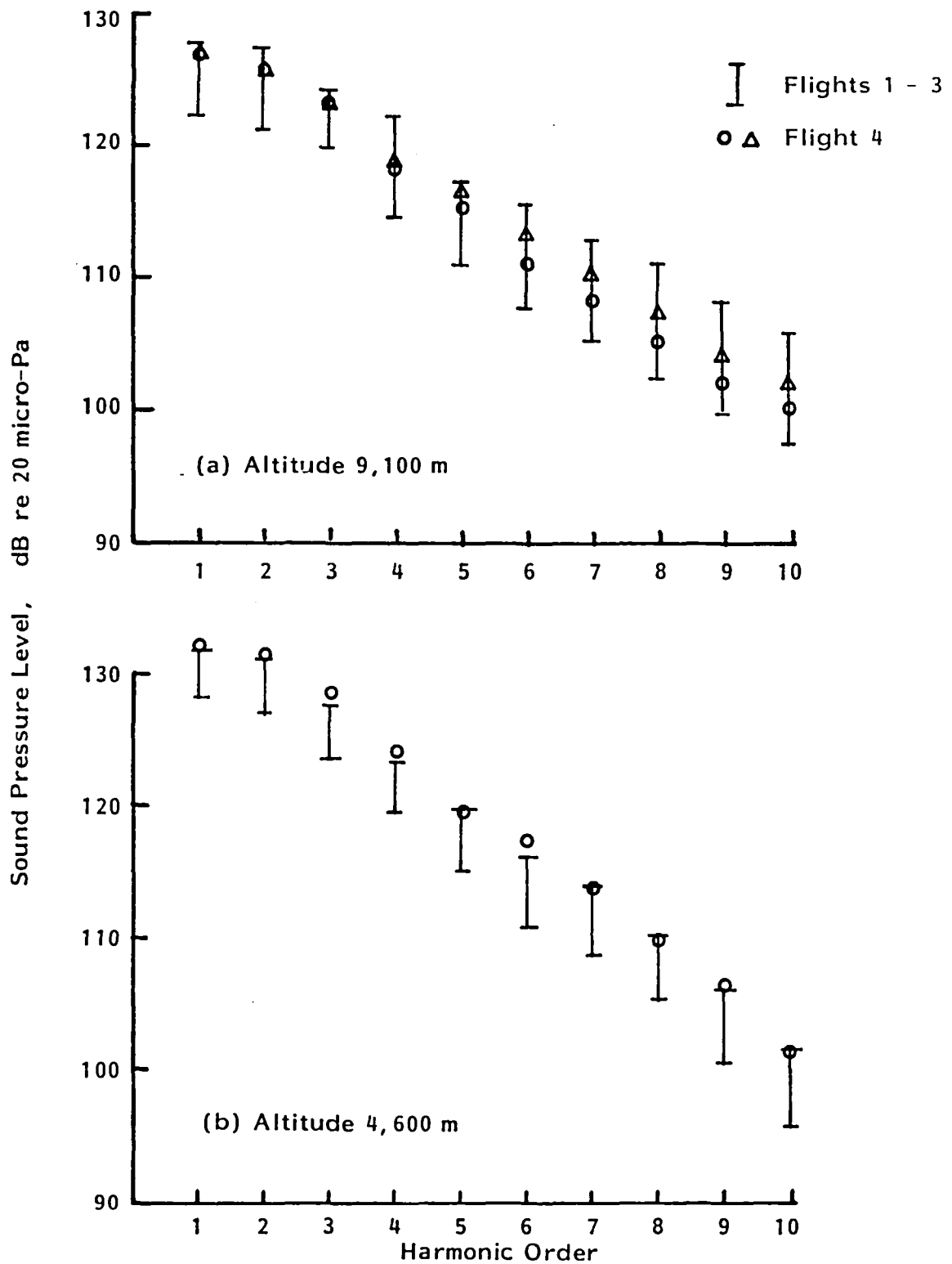

FIGURE 13. VARIABILITY OF HARMONIC SOUND LEVELS ON EXTERIOR OF FUSELAGE. (COMPONENT FROM NEAREST PROPELLER, PORT SIDE, LOW RPM)

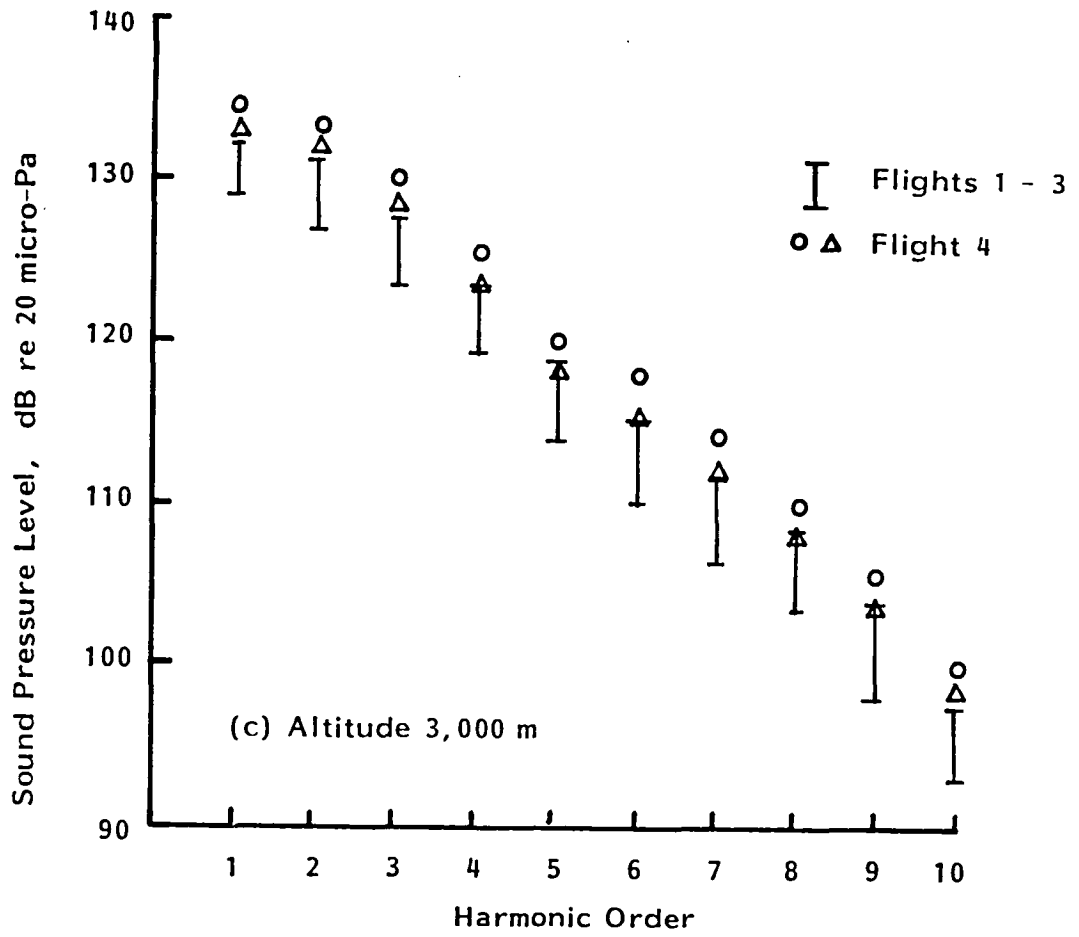

FIGURE 13. CONTINUED

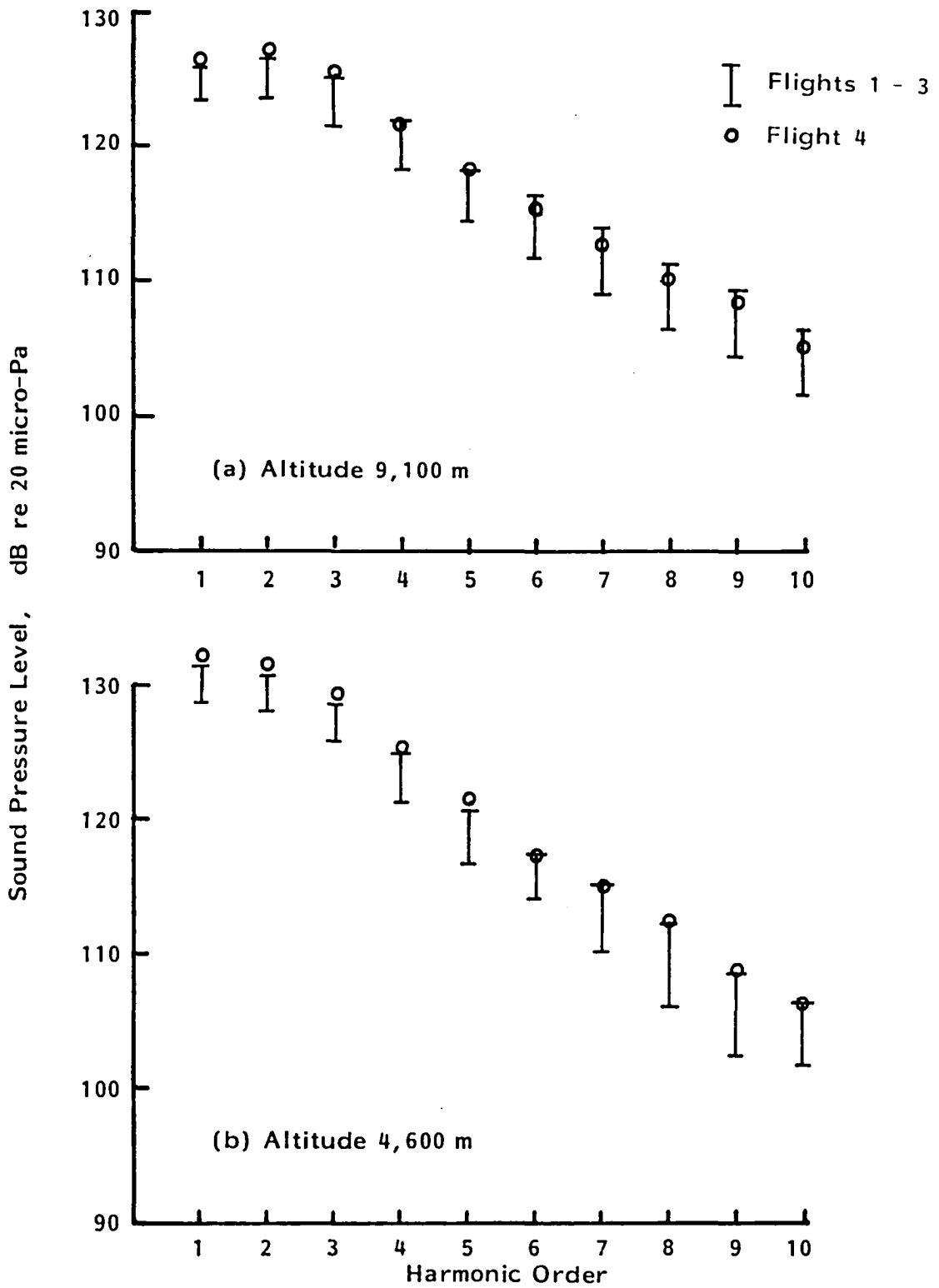

FIGURE 14. VARIABILITY OF HARMONIC SOUND LEVELS ON EXTERIOR OF FUSELAGE. (COMPONENT FROM NEAREST PROPELLER, PORT SIDE, HIGH RPM)

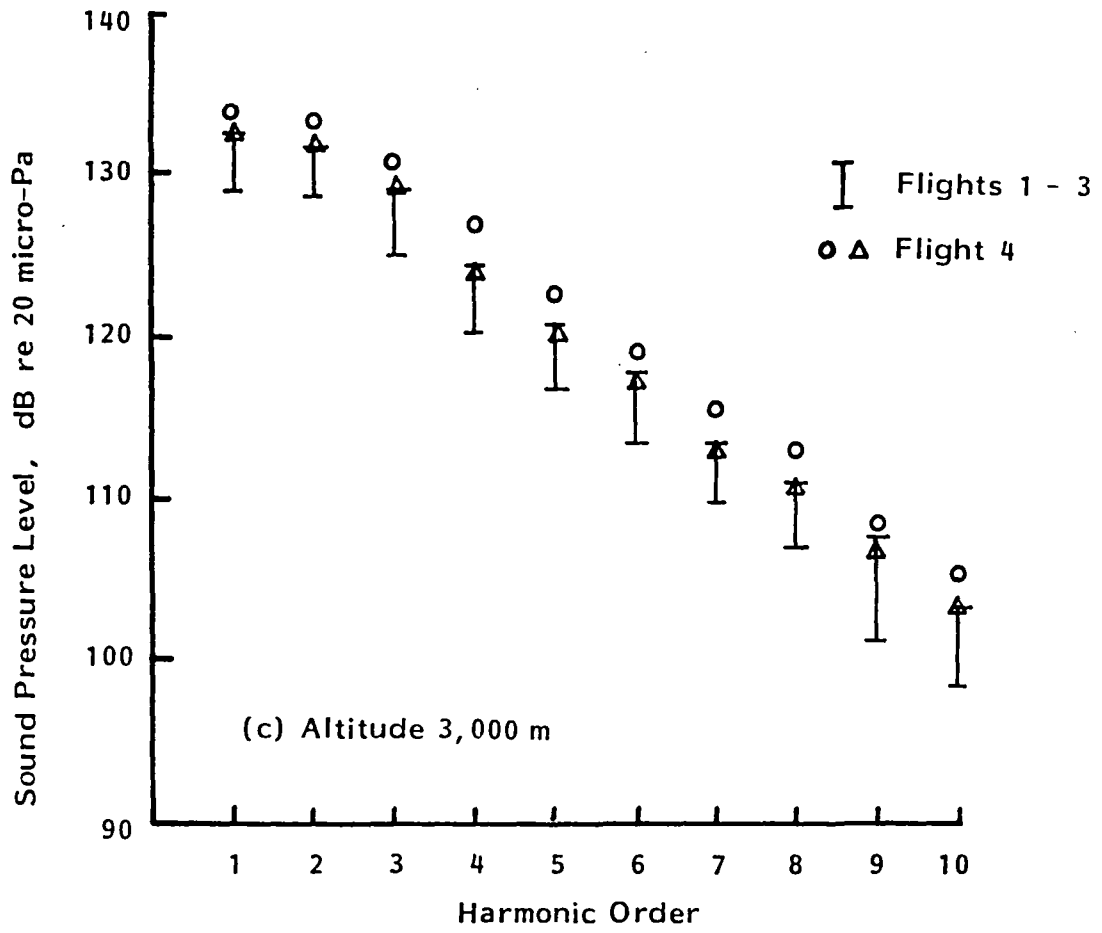

FIGURE 14. CONTINUED

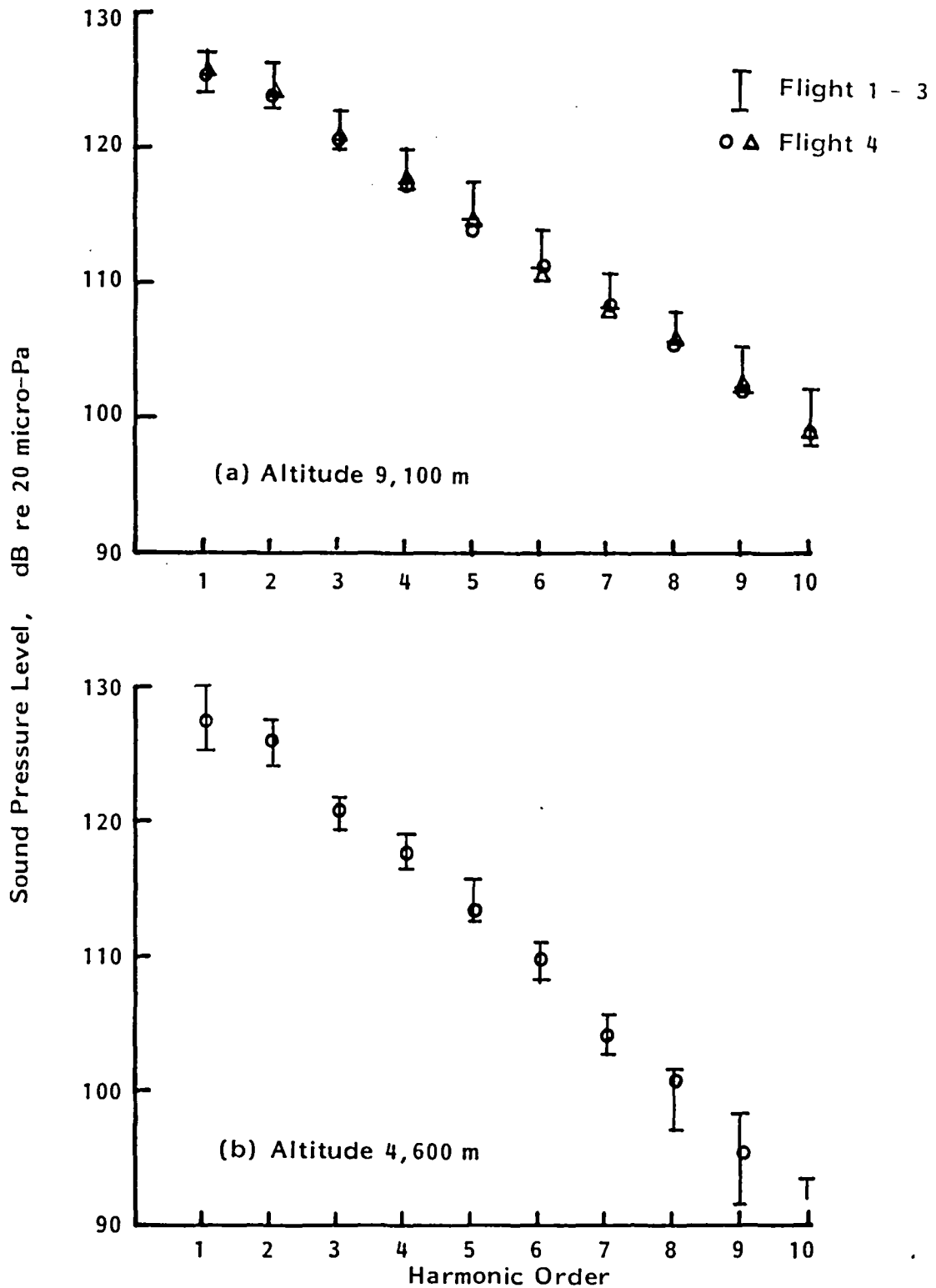

FIGURE 15. VARIABILITY OF HARMONIC SOUND LEVELS ON EXTERIOR OF FUSELAGE. (COMPONENT FROM NEAREST PROPELLER, STARBOARD SIDE, LOW RPM)

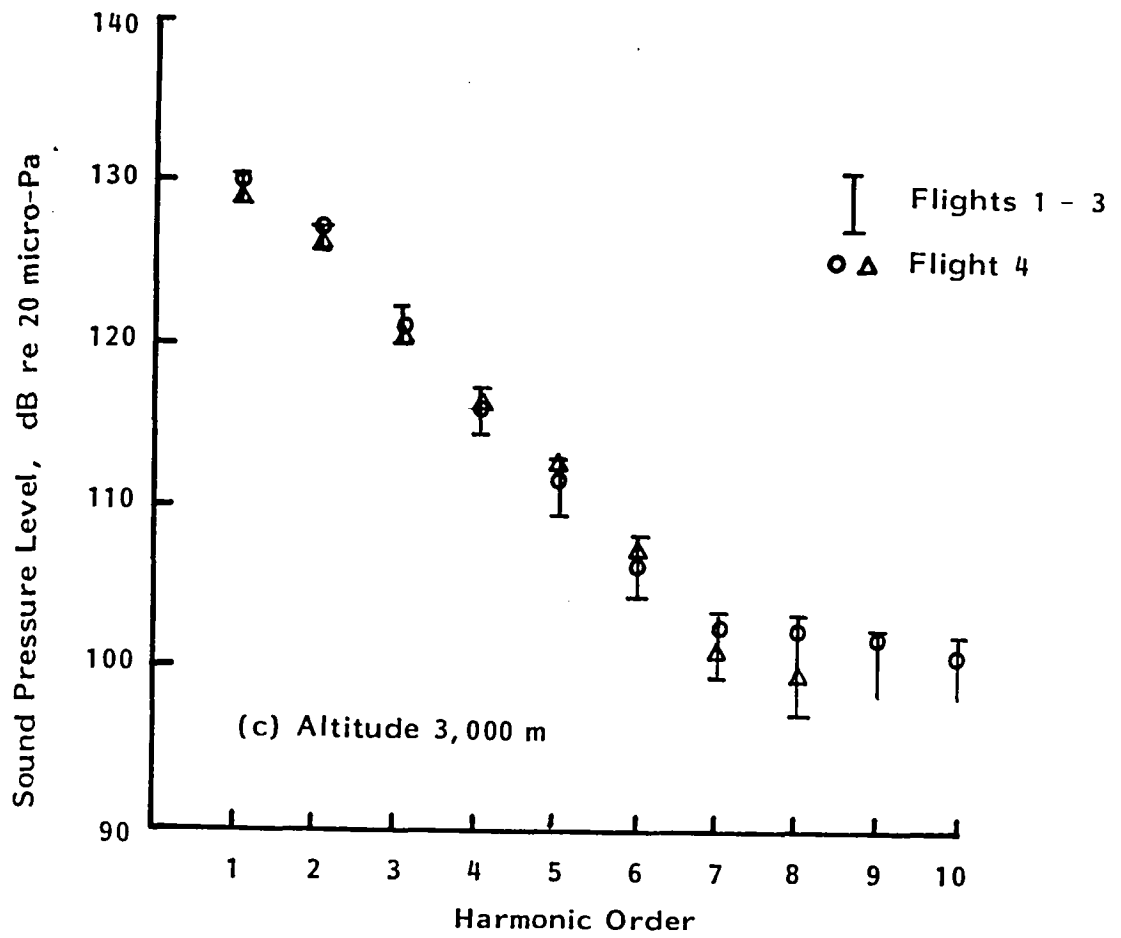

FIGURE 15. CONTINUED

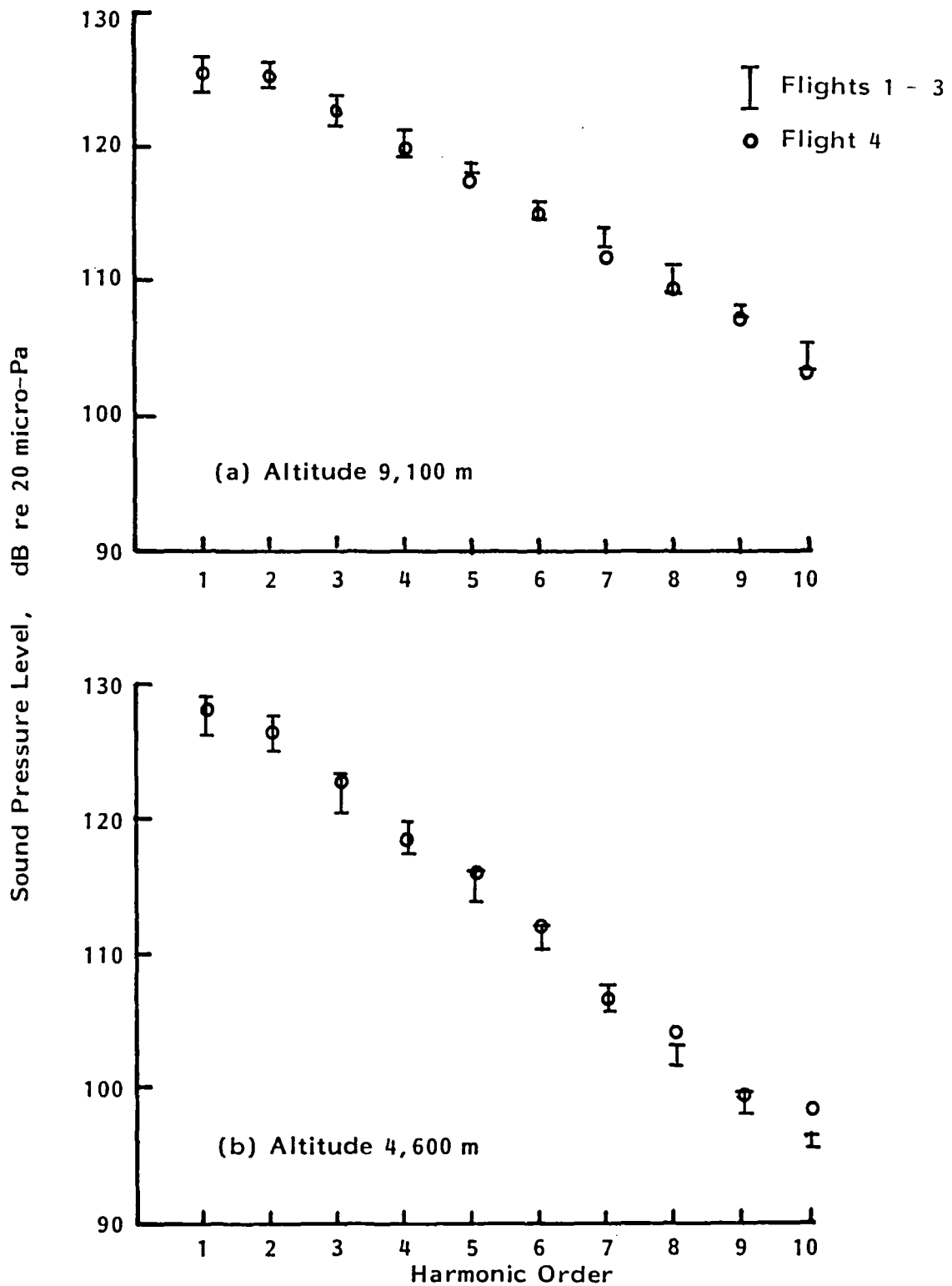

FIGURE 16. VARIABILITY OF HARMONIC SOUND LEVELS ON EXTERIOR OF FUSELAGE. (COMPONENT FROM NEAREST PROPELLER, STARBOARD SIDE, HIGH RPM)

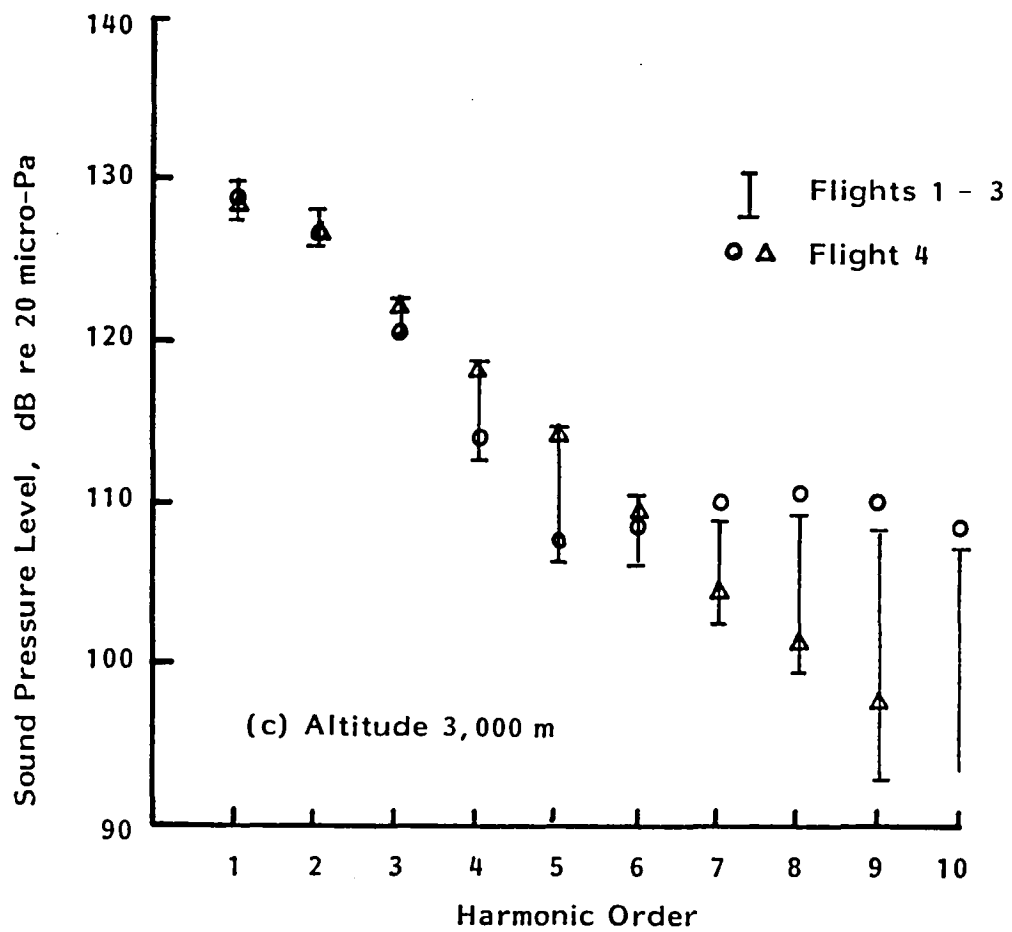

FIGURE 16. CONTINUED

3.3 Comparison of Port and Starboard Levels

A comparison of the measured data ranges shown in Figures 13 through 16 indicates that the harmonic sound pressure levels on the port side of the fuselage are equal to, or greater than, those on the starboard side. Such a comparison, taken from data in Figures 13 and 15 for low propeller rpm conditions is shown in Figure 17.

At a nominal altitude of 9,100 m (30,000 ft) the harmonic sound pressure levels for the port and starboard propellers at low rpm are similar in value, as shown in Figure 17(a). Overall sound pressure levels, obtained by summing over the ten lowest-order harmonics, range from 127.2 dB to 131.8 dB for the port propeller and 128.8 to 131.2 dB for the starboard propeller. At a nominal altitude of 4,600 m (15,000 ft) the test data show that the harmonic sound pressure levels are significantly higher for the port propeller than for the starboard. This comparison is shown in Figure 17(b); overall sound pressure levels now lie in the range of 132.1 dB to 136.2 dB for the port propeller and 129.4 dB to 132.7 dB for the starboard. Similar trends can be found in the data associated with the high rotational speed of the propeller. Also, results for an altitude of 3,000 m are similar to those for 4,600 m. A comparison of overall sound pressure levels is given in Table 9.

When the data are compared with previous results a similar trend can be found. In the previous test, overall sound pressure levels for port and starboard propellers (again computed by summing the harmonic contributions) differed by about 1 dB at an altitude of 8,800 m and by 2.5 to 6.1 dB at 4,600 m, with the port propeller being associated with the higher sound pressure levels.

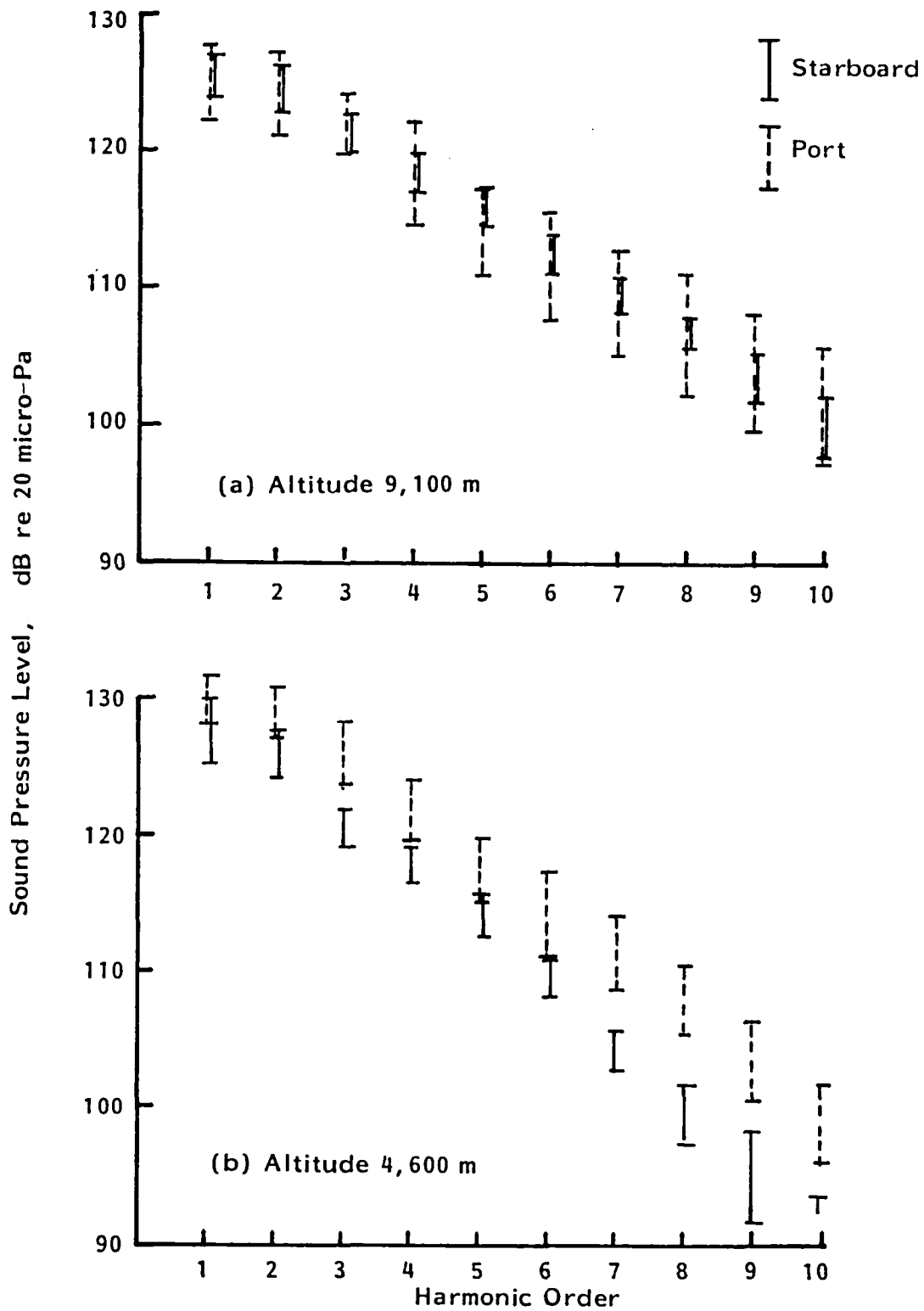

FIGURE 17. COMPARISON OF RANGE OF HARMONIC SOUND PRESSURE LEVELS GENERATED BY PORT AND STARBOARD PROPELLERS. (FLIGHTS 1-4)

TABLE 9
MEASURED AND PREDICTED EXTERIOR OVERALL SOUND PRESSURE
LEVELS ASSOCIATED WITH PROPELLER DISCRETE FREQUENCY SOUND

Airplane Altitude m (ft)	No. of Engines	Prop RPM	Overall Sound Pressure Level** dB re 20 micro Pa			
			Predicted* [21] [22]		Port	Measured Starboard
3,000 (10,000)	2	Low	144.1	139.5	132.2-138.2	131.0-133.1
	2	High	144.4	140.0	133.5-138.5	130.8-132.9
4,600 (15,000)	2	Low	144.3	139.9	132.1-136.2	129.4-132.7
	2	High	144.4	140.4	133.0-136.3	129.9-132.5
4,600 (15,000)	1	Low	144.1/ 143.7	139.6/ 139.2	128.2-133.0	130.2-132.2
9,100 (30,000)	2	Low	141.9	137.5	127.2-131.8	128.8-131.2
	2	High	142.2	138.0	128.5-131.9	129.8-131.8

* Port/Starboard

** Computed as an energy sum of harmonic components for harmonic orders 1 through 10.

3.4 Comparison with Simplified Predictions

Two simplified prediction procedures [21, 22] are available for estimating propeller-induced fluctuating pressure levels on the fuselage exterior. Both procedures are essentially empirical in nature and rely on fairly rudimentary descriptions of the propeller performance. They require significantly less detailed information regarding the propeller than do the analytical models that have been developed recently.

The two methods [21, 22] have been used previously to compare with measured pressure levels on an early piston-engine Commander airplane operating under static and taxi conditions [15-18]. In that study it was found that the SAE procedure [21] was the more accurate under static conditions, but the method described in Ref. 22 became the more reliable method when the airplane had forward motion. Both procedures have been applied to the present test airplane in an earlier investigation and are being applied again to the present data.

First, the overall sound pressure levels can be compared. In the case of the test data, these levels are obtained by an energy sum of the harmonic components for harmonics 1 through 10. Prediction of the overall levels requires a knowledge of propeller tip rotational and helical Mach numbers, propeller power, diameter and number of blades, and the location of the observation point. These input data values are available immediately with the exception of the propeller power. This was estimated using the simple relationship between power, rpm and torque, and the assumption that 100% torque was associated with 820 shp at maximum rpm.

A comparison of measured and predicted overall sound pressure levels is given in Table 9 where it is seen that both prediction

procedures over-estimate the measured levels. The largest discrepancies occur when the SAE procedure [21] is used. On an average, the method over-estimates the overall sound pressure levels by about 11 dB. The second procedure [22] overestimates the measured levels by, on the average, 7 dB. These discrepancies are similar to those of a previous test where average differences of 8 dB and 4 dB, respectively, were observed.

Because of the differences between measured and predicted overall sound pressure levels, the comparison of harmonic levels can be done most conveniently when the levels are expressed relative to overall values. Differences in overall levels are then removed from the discussion. Comparisons in this basis are given in Figures 18 through 21.

Comparing first the measured data for the port and starboard propeller, it is seen that the port propeller generally has the higher normalized harmonic sound levels at an altitude of 3,000 m and the lower levels at 9,100 m. At the intermediate altitude of 4,600 m the measured normalized sound levels are similar for the port and starboard propellers.

The prediction procedures do not differentiate between clockwise and counter-clockwise directions of rotation. Thus, a single curve is given for both port and starboard propellers. When predicted and measured sound pressure levels are compared, it is seen that the measured levels generally lie between the two predicted curves, but they tend to be closer in value to the results using Ref. 22 than to the SAE method [21] at all harmonic orders. This result is slightly different from that of a previous test program where the measured normalized harmonic levels tended to follow the predictions of Ref. 22.

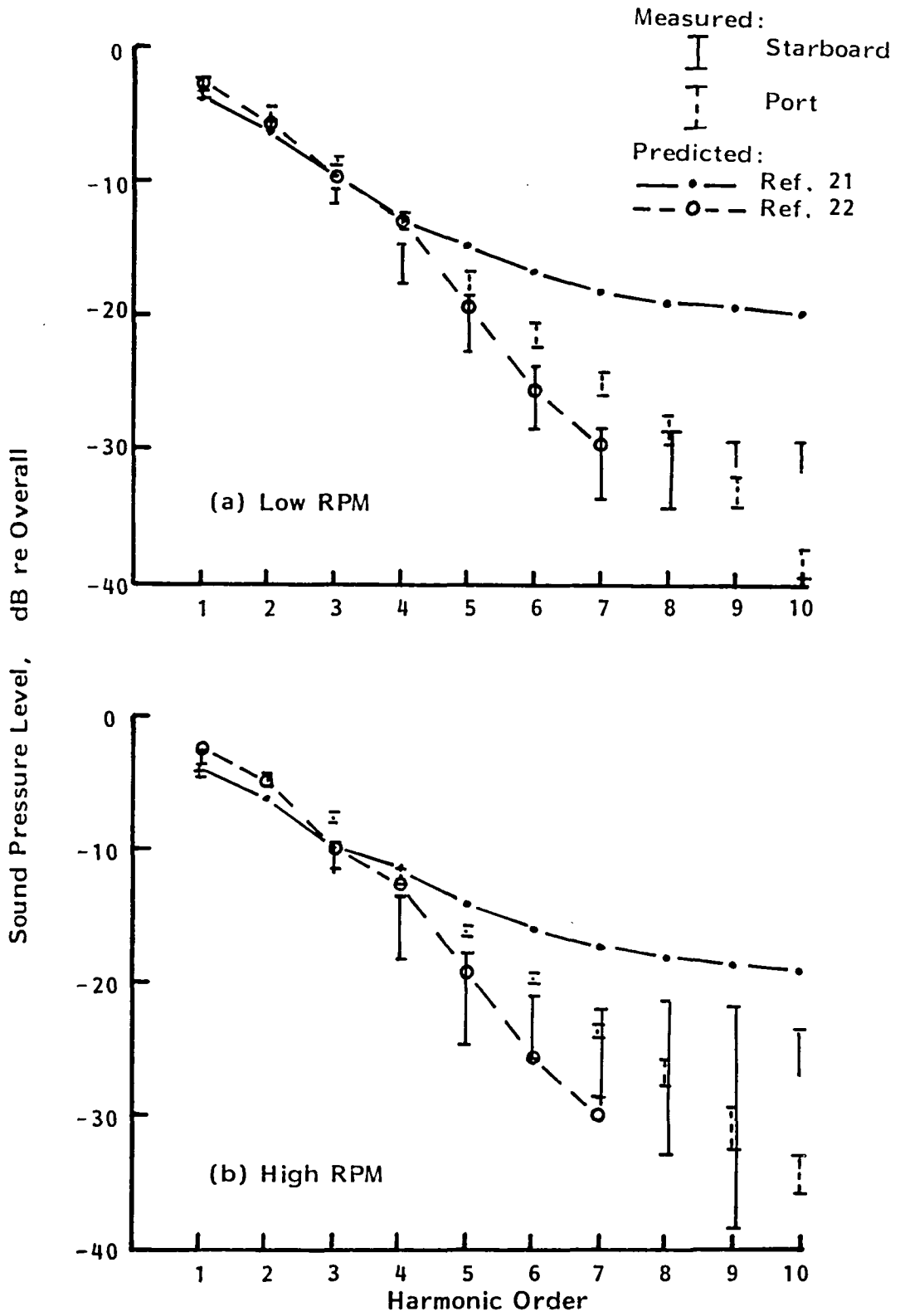

FIGURE 18. COMPARISON OF MEASURED AND PREDICTED PROPELLER HARMONIC SOUND PRESSURE LEVELS: 3,000 m ALTITUDE.

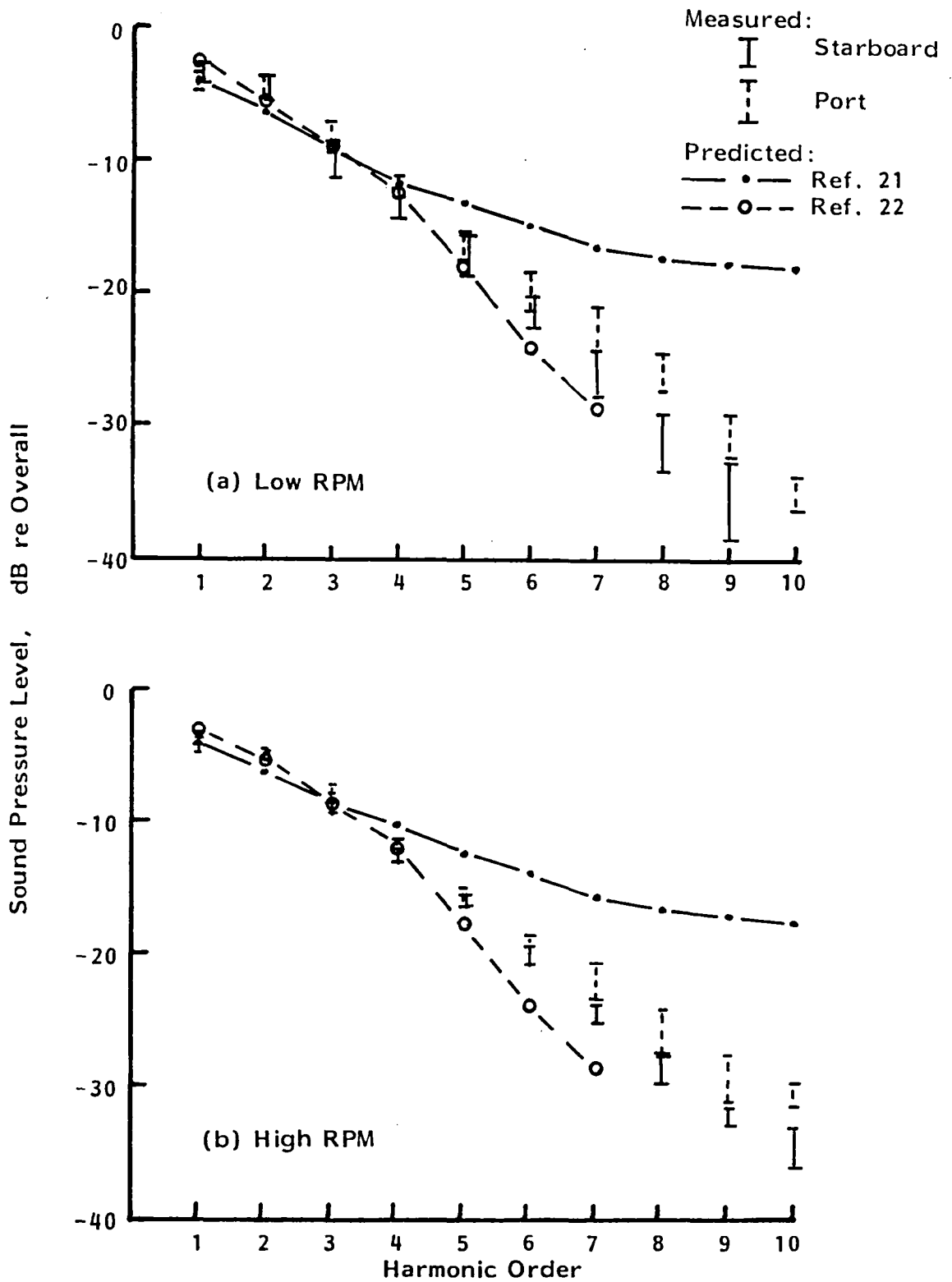

FIGURE 19. COMPARISON OF MEASURED AND PREDICTED PROPELLER HARMONIC SOUND PRESSURE LEVELS: 4,600 m ALTITUDE, TWO-ENGINE OPERATION.

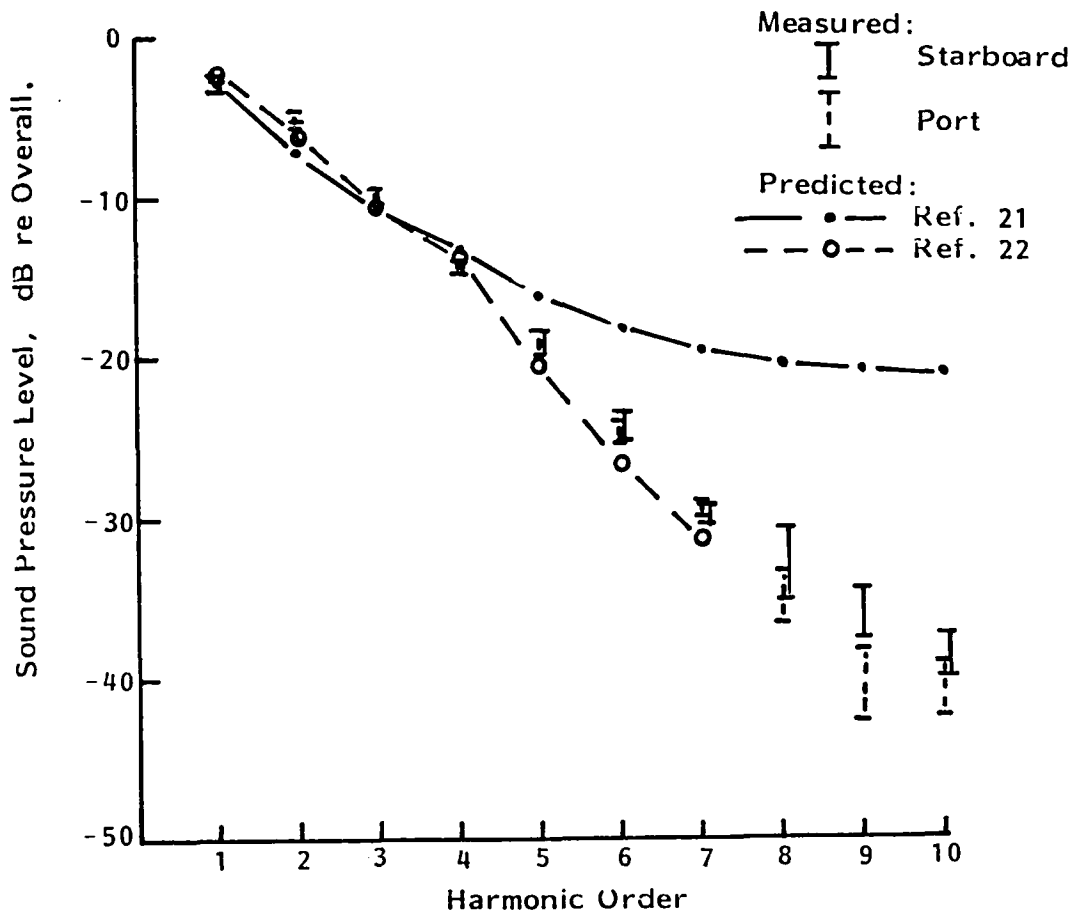

FIGURE 20. COMPARISON OF MEASURED AND PREDICTED PROPELLER HARMONIC SOUND PRESSURE LEVELS: 4,600 m ALTITUDE, SINGLE-ENGINE OPERATION.

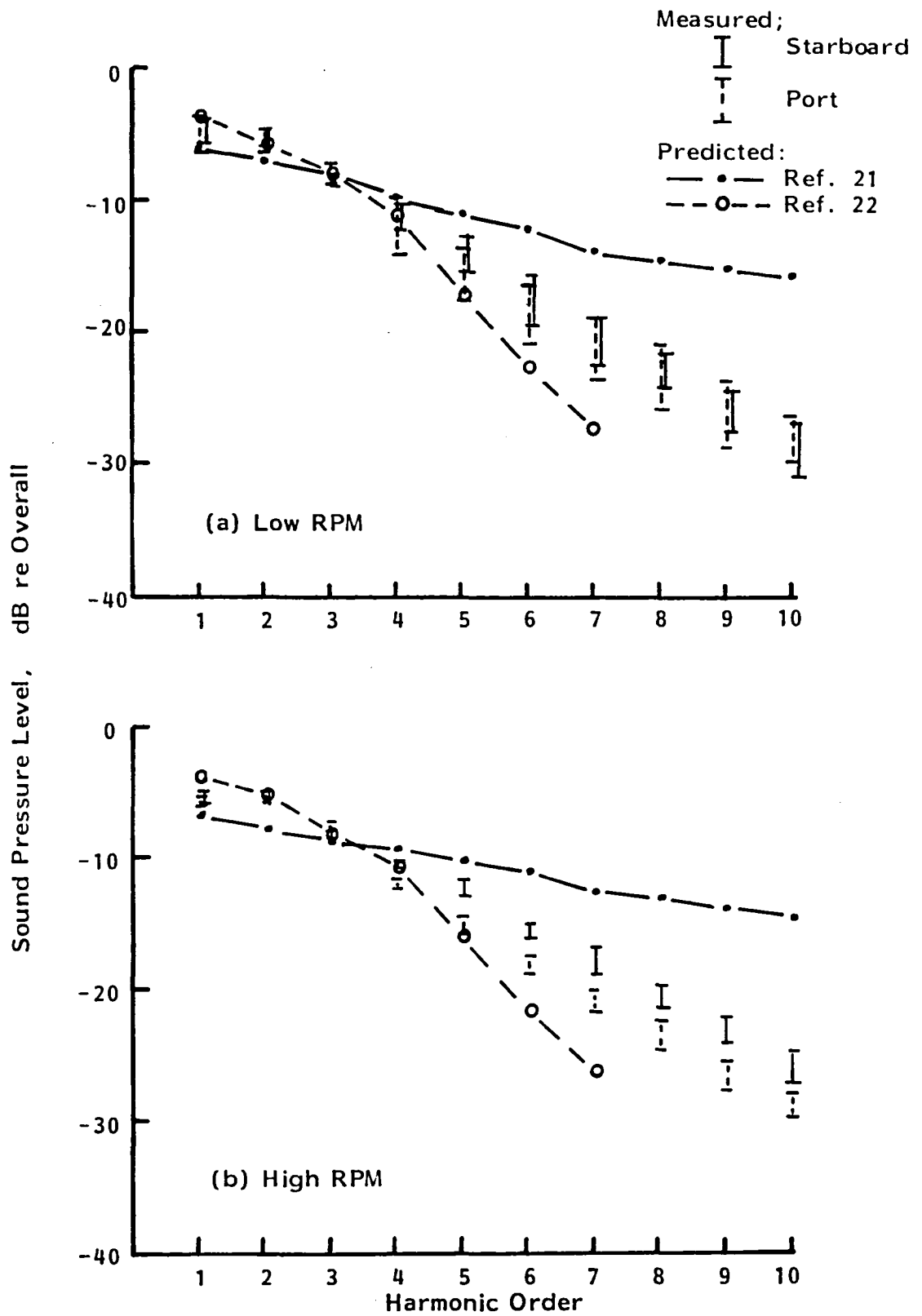

FIGURE 21. COMPARISON OF MEASURED AND PREDICTED PROPELLER HARMONIC SOUND PRESSURE LEVELS: 9,100 m ALTITUDE.

3.5 Relative Phase

When the two propellers were operated under control of the synchrophaser it was possible (except for flight #4) to adjust the relative phase between the two propellers. This was accomplished by adjustment of a knob on the pilot control panel, but there was no indication of the actual phase setting. Consequently, an attempt was made to measure the relative phase using the pressure signals recorded by the two flush mounted microphones.

Figure 22 compares simultaneous segments from pressure time histories measured by the port and starboard flush-mounted microphones during condition 7 of flight #3. The time histories show the repetitive pressure pulses associated with the passage of the propeller blades, but superimposed on these patterns is random noise. This noise complicates the measurement of time differences between pulses of the two time histories. The random component can be removed by time averaging of the pressure signals, as was done by Piersol, et al [16] or by cross-correlation techniques.

The latter approach is possible because of the periodic deterministic character of the pressure signatures generated by the two propellers. Figure 23 shows how the irregularities in the pressure time histories are smoothed out by the averaging involved in the cross-correlation process.

The relative phase between the two propellers can now be determined from the time delay to the peak in the cross-correlation function. For present purposes the peak used is that closest to zero time delay. If τ_1 is the time delay to the correlation maximum closest to the origin, and τ_m is the time delay between adjacent maxima ($\tau_m = 1/f_b$, where f_b is the propeller blade

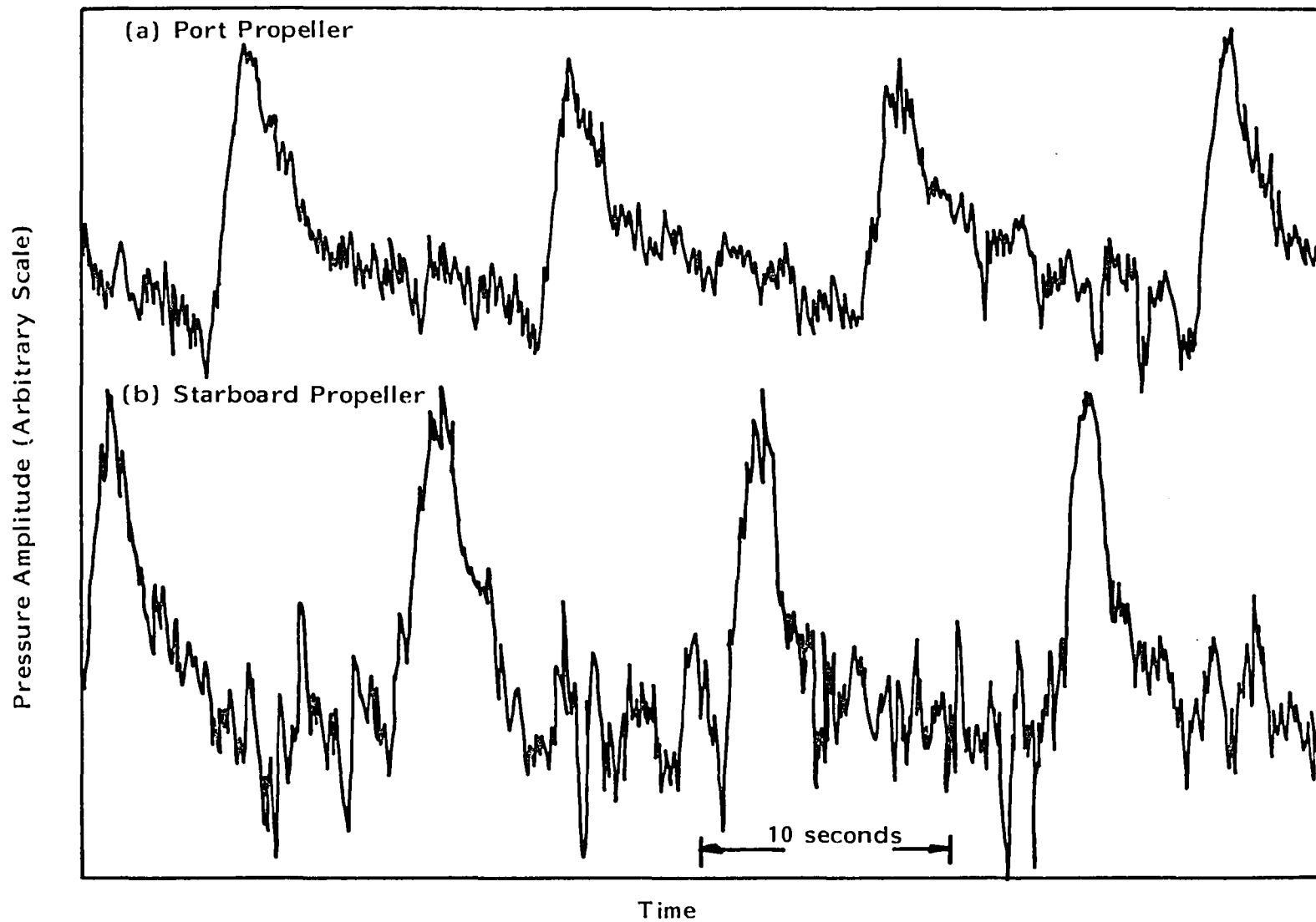

FIGURE 22. TYPICAL PROPELLER PRESSURE TIME HISTORIES MEASURED ON EXTERIOR OF FUSELAGE.

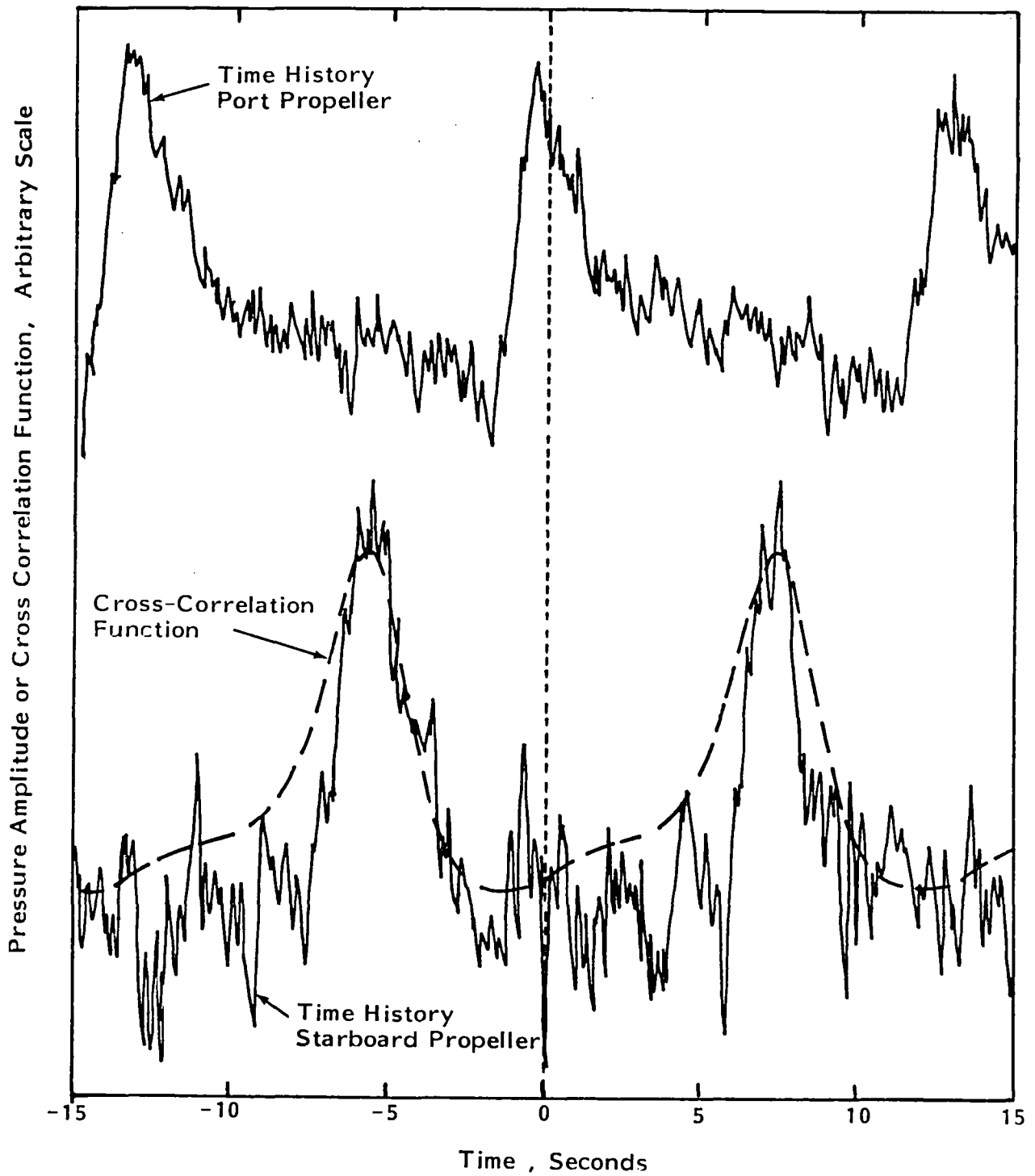

FIGURE 23. COMPARISON OF PROPELLER PRESSURE TIME HISTORIES AND CROSS CORRELATION FUNCTION FOR THE TWO SIGNALS.

passage frequency), then the relative phase between the two propellers is given by

$$\phi = \frac{\tau_1}{\tau_m} \times 360 \text{ degrees}$$

Resulting values for the relative phase angle are given in Table 10 for test conditions from the first three flights. Data for the one test condition for which propellers were operated at the same rpm during the fourth flight (identified as condition 13 in Table 5) showed that the synchrophaser was not engaged and the relative phase between the two propellers was drifting out of control.

Inspection of the data in Table 10 for test conditions 5 through 8 (airplane nominal altitude of 4,600 m or 15,000 ft) shows that there is reasonable consistency, with phase repeatability from flight to flight of about ± 10 degrees. In contrast, the data for test conditions 13 through 16 (altitude of 9,200 m) show inconsistencies among themselves and when compared to data for an altitude of 4,600 m. For example, phase angles measured for conditions 13 and 14 of flight #2 differ from corresponding values for flights #1 and #3. Also, phase angles for similar nominal settings of the pilot's control knob (e.g. test conditions 5 and 13) have different values at 4,600 m and 9,200 m altitudes*

*Subsequent discussions with the manufacturer of the synchrophaser indicate that the phase angle data are not as inconsistent as first thought. The synchrophaser on the test airplane had a stability of about $\pm 12^\circ$ and the phase difference for a given setting of the selector knob would depend on propeller rpm and torque. Since there are differences in rpm and torque between conditions 5-8 and 13-16, the relative phase would also show differences. Furthermore, for conditions 13-16, propeller rpm had similar values for flights 1 and 2, but different values for flight 3; this pattern appears in the relative phase values in Table 10.

TABLE 10

RELATIVE PHASE BETWEEN PORT AND STARBOARD PROPELLERS

Flight	1	2	3	Average	
Condt. Ident	Relative Phase (degrees)*			Phase (deg)	
5	---	+12	-7	+3	<u>+10</u>
6	---	+99	+111	+105	<u>+6</u>
7	-149	-148	-136	-144	<u>+7</u>
8	-25	-17	-24	-22	<u>+4</u>
13	-118	+152	-84		
14	-10	-133	+4		
15	---	+17	+127		
16	---	+116	-114		

*Relative phase expressed within range $\pm 180^\circ$. Positive sign indicates that port propeller leads the starboard propeller, negative sign indicates that port propeller lags.

3.6 Turbulent Boundary Layer

The turbulent boundary layer on the exterior of the fuselage will generate random pressure fluctuations which will appear as broadband noise in the signals from the flush-mounted microphones. Thus, it is of interest to compare the broadband components in the exterior fluctuating pressure spectra with predicted contributions from the boundary layer. The prediction method used is an empirical procedure based on measurements made on a Boeing 737 airplane [23]. The method was found to give good agreement with test data

from large aircraft and from wind tunnel tests, where the turbulent boundary layer is well established. In the present case, it is possible that the external flow at the measurement location could be influenced by upstream disturbances associated with flow around the windshield or by flow on the neighborhood of the wing/fuselage junction. The prediction procedure assumes an idealized condition of flow over a flat plate with zero pressure gradient. It was found, however, that alternating regions of adverse and favorable pressure gradients, such as occur, for example, along the fuselage of a Boeing 737 have a negligible influence on the fluctuating pressure field.

Predicted broadband spectrum levels associated with the turbulent boundary layer are superimposed on measured data from flight #3 in Figures 9 through 12. It is seen that the predicted and measured levels are in close agreement, with the slope of the predicted spectra being slightly less than that of the measurements. Where differences exist between measurements and predictions, no general trend can be found, the predictions sometimes being higher than the measurements and sometimes lower. Thus, it seems reasonable to conclude that the measured broadband pressure fluctuations are due to the turbulent boundary layer on the exterior of the fuselage and that the data show a variability of ± 1 dB to ± 2 dB.

3.7 One-Third Octave Band Spectra

One-third octave band spectra for the exterior pressure field are listed in Appendix D for Flights 3 and 4. The spectra are presented for the frequency range 25 to 5000 Hz. Typical spectra are shown in Figure 24; these spectra correspond to narrowband spectra presented in Figures 9 and 10. Since the spectrum levels at frequencies below about 800 Hz are dominated by discrete frequency components associated with the propeller blade passage frequency,

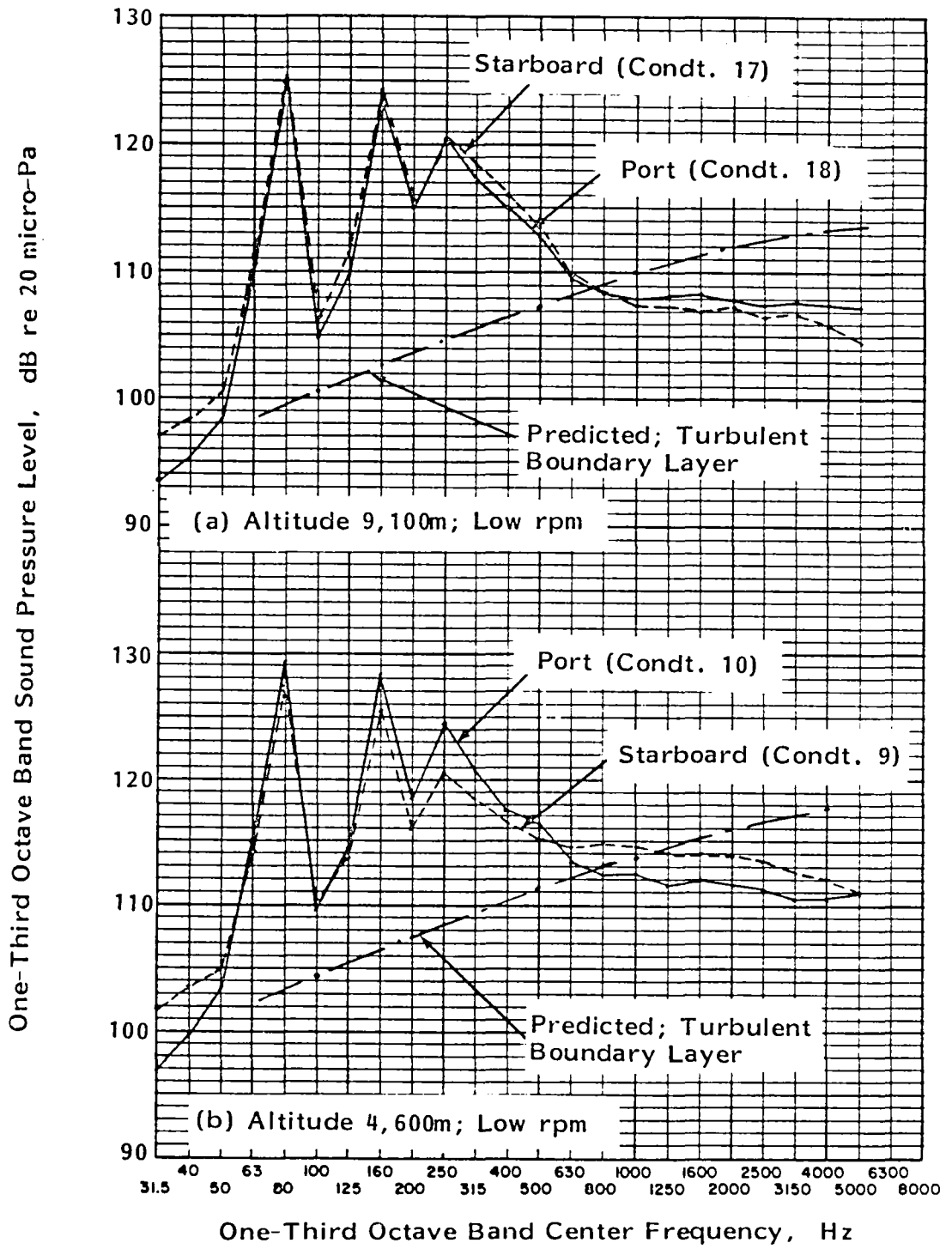

FIGURE 24. COMPARISON OF MEASURED EXTERIOR ONE-THIRD OCTAVE BAND PRESSURE SPECTRA AND PREDICTED TURBULENT BOUNDARY LAYER PRESSURE LEVELS.

the one-third octave band spectra are probably of most interest at higher frequencies.

Superimposed on the measured spectra are predicted one-third octave band levels for turbulent boundary layer pressure fluctuations. The agreement between measured and predicted levels does not seem to be as good as it was for the narrowband spectra. At low frequencies, the apparent discrepancy is due to the dominance of propeller noise in determining one-third octave band levels. At high frequencies, the discrepancy could be associated with the effect of transducer size; the finite size of the microphone diaphragm results in reduced response to high frequency (high wavenumber) pressure components. A more-detailed analysis would require allowance for transducer size, but such analysis is outside the scope of this study.

4.0 SOUND LEVELS IN UNTREATED CABIN

4.1 Narrowband Spectra

The main frequency characteristics of the sound field in the untreated cabin can be seen in Figure 25 which is associated with both propellers operating at the same speed. The spectrum is dominated by discrete frequency components at multiples of the propeller blade passage frequency. Secondary peaks occur at multiples of the shaft rotational frequency (which is one-third of the blade passage frequency) and at the turbine shaft rotational frequency. These secondary peaks are, perhaps, more in evidence than is the case for the exterior pressure field. Sound pressure levels at harmonics of the blade passage frequency are listed in Appendix B for all test conditions and for the ten lowest order harmonics (where present).

Inspection of the propeller harmonic components shows that the associated sound levels vary irregularly with frequency or harmonic order. This is in contrast to the exterior pressure measurements (see, for example, Figures 9 through 12) where the sound levels generally decrease monotonically as frequency increases. As might be expected, the transfer function introduced by the fuselage structure and cabin volume changes markedly with frequency.

The effect of the transfer function can be seen also in the broadband sound pressure levels. The relatively uniform broadband levels seen in Figure 9 through 12 becomes a very irregular pattern in the cabin sound level spectra. This is due, at least in part, to structural and acoustic resonances.

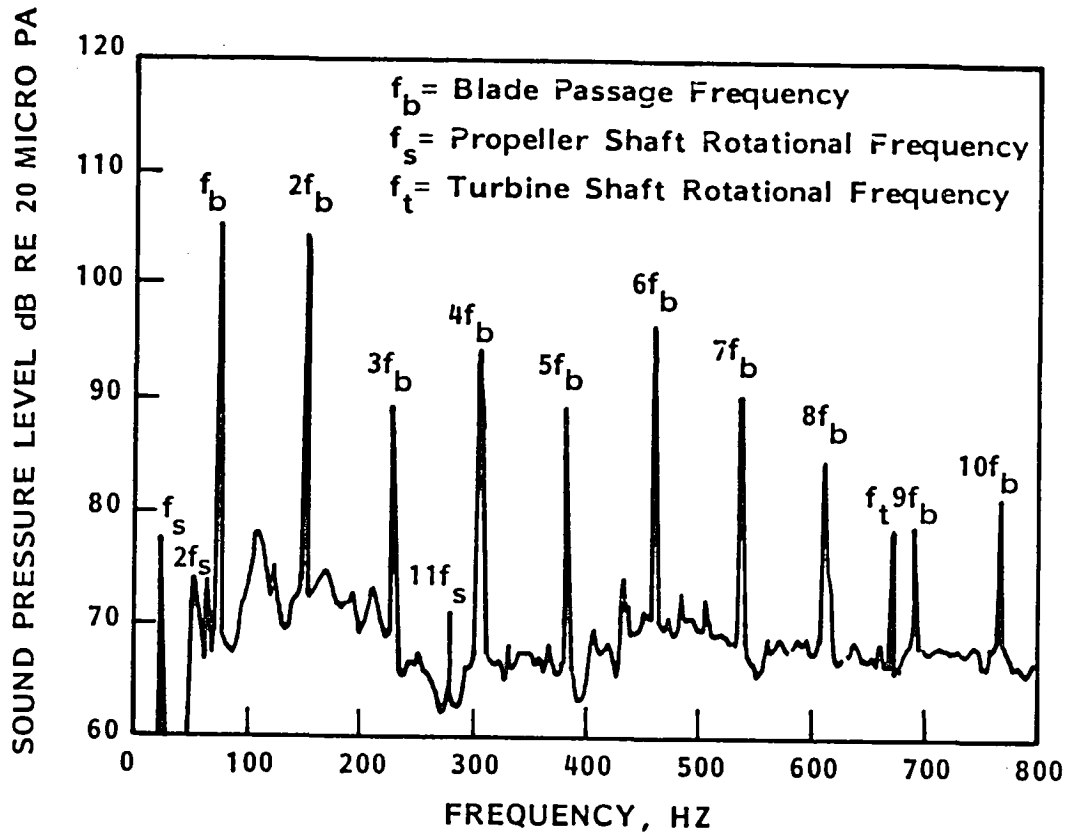

FIGURE 25. TYPICAL NARROWBAND SOUND PRESSURE SPECTRUM MEASURED IN UNTREATED CABIN.

Narrowband acoustic spectra associated with operation of the two propellers at different rotational speeds are given in Figures 26 and 27 for two nominal flight altitudes. In one case (Figure 26) the port propeller is at low rpm and the starboard propeller at high rpm; in the other case (Figure 27) the converse is true. As was the case for the exterior pressure field, the cabin acoustic spectra show more harmonic content at the higher flight altitude. Cabin acoustic spectra associated with single-engine operation are shown in Figure 28. The spectra are shown for two conditions, with a strong turbine component present in both cases.

4.2 Harmonic Data Variability

An analysis of the variability of harmonic sound pressure levels measured inside the cabin is more complicated than for the exterior pressure field. There are several possible reasons for the complications, one of them being the constructive and destructive interference between acoustic signals from the two propellers.

To illustrate the magnitude of the data variability, harmonic sound pressure levels have been compared for several repeated flight conditions. This is done first (Figures 29 and 30) for flight conditions 9 and 10, where the propellers were operated at different rotational speeds at an altitude of 4600 m (15000 ft) and the cabin was untreated. Two cabin microphones (#3 and #6) are considered, these microphones being approximately in the plane of rotation of the propellers and about half-way along the cabin. The figures present data for the port and starboard propellers at both low and high rpm conditions. It is not the intent of these figures to compare port and starboard propeller components, although some large differences can be seen. Rather, the intent is to show the data variability for either the port or starboard propeller when considered separately.

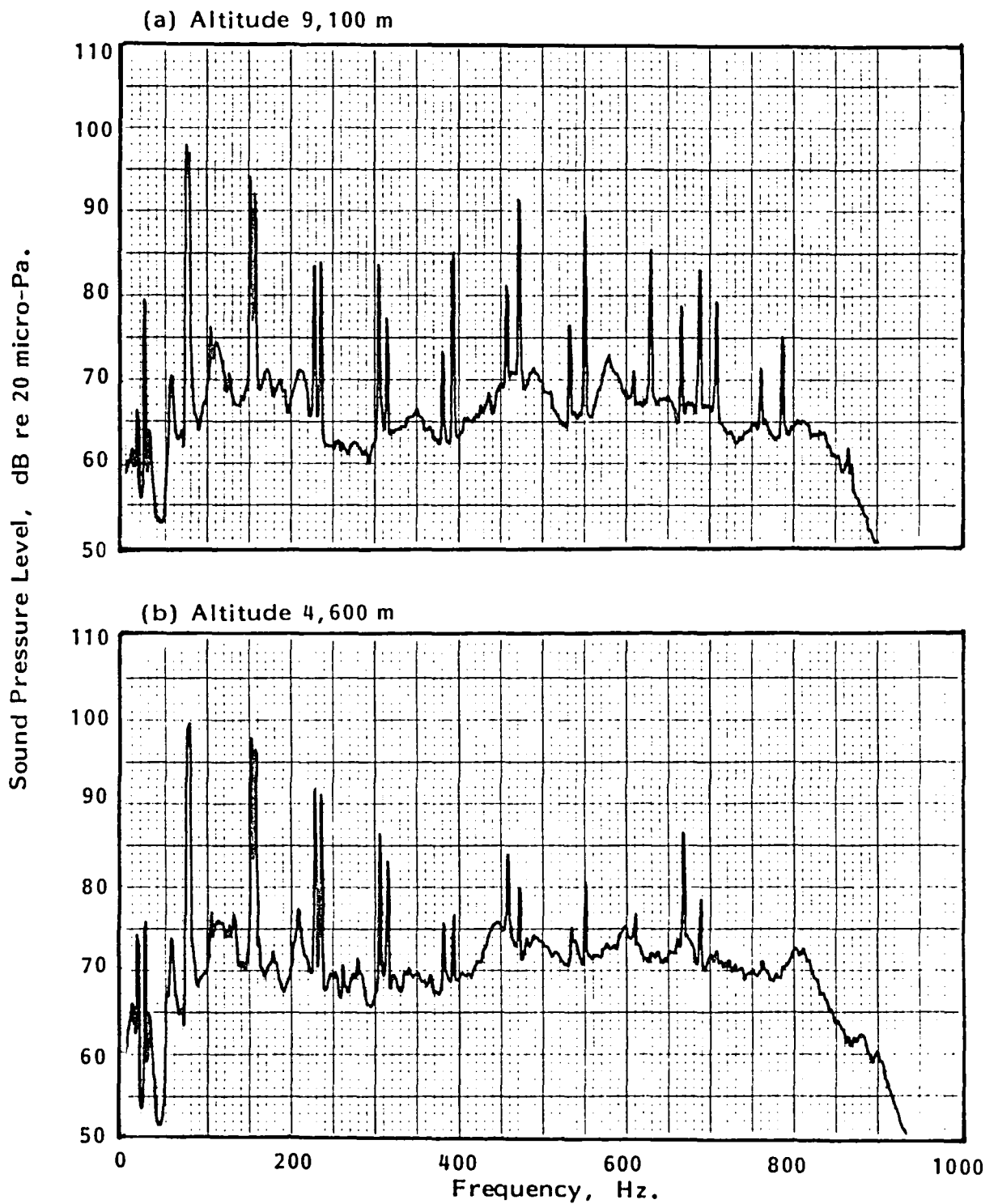

FIGURE 26. NARROWBAND SPECTRA OF CABIN SOUND PRESSURE LEVELS AT LOCATION 3; PORT PROPELLER, LOW RPM; STARBOARD PROPELLER, HIGH RPM.

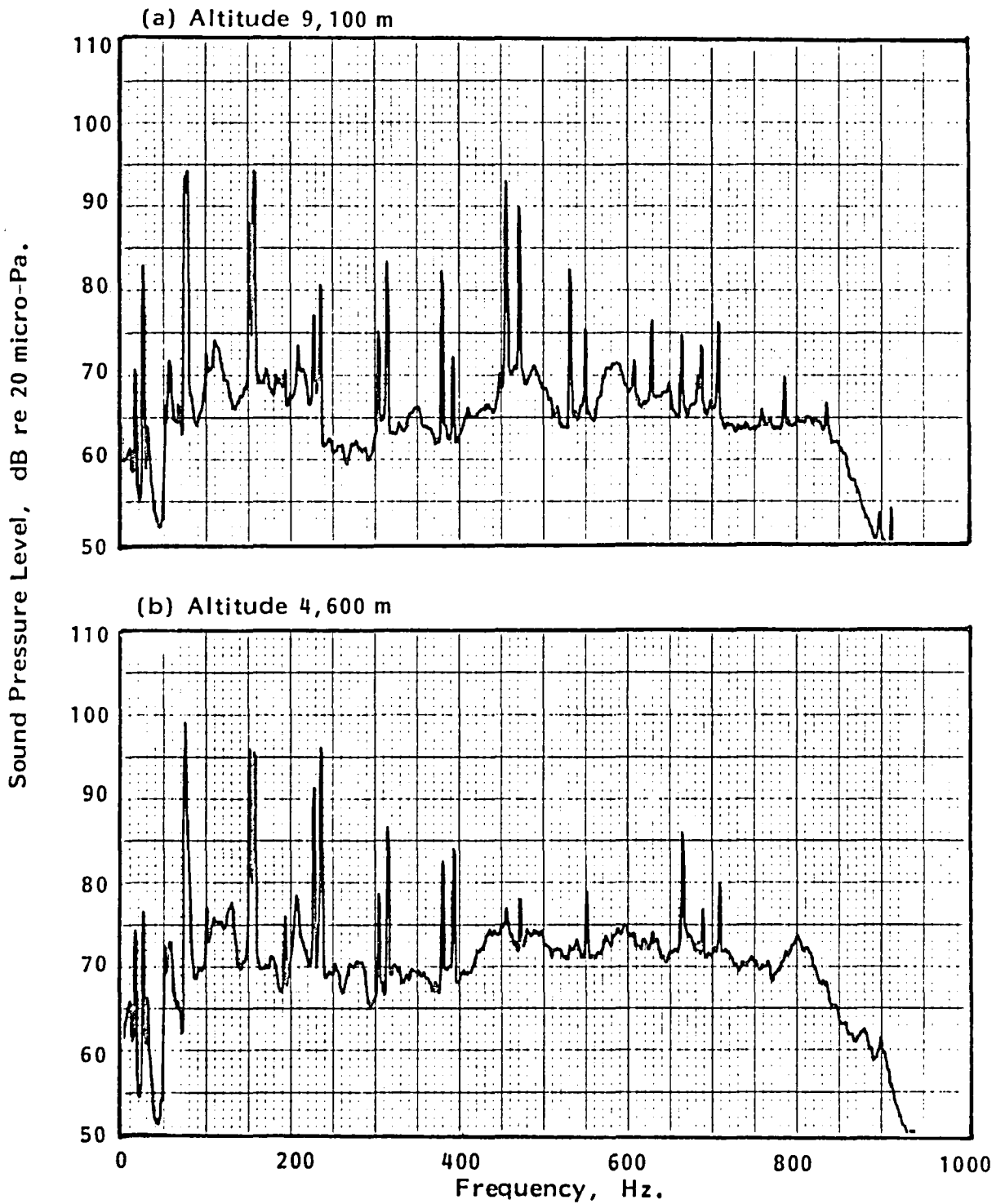

FIGURE 27. NARROWBAND SPECTRA OF CABIN SOUND PRESSURE LEVELS AT LOCATION 3; PORT PROPELLER, HIGH RPM; STARBOARD PROPELLER, LOW RPM.

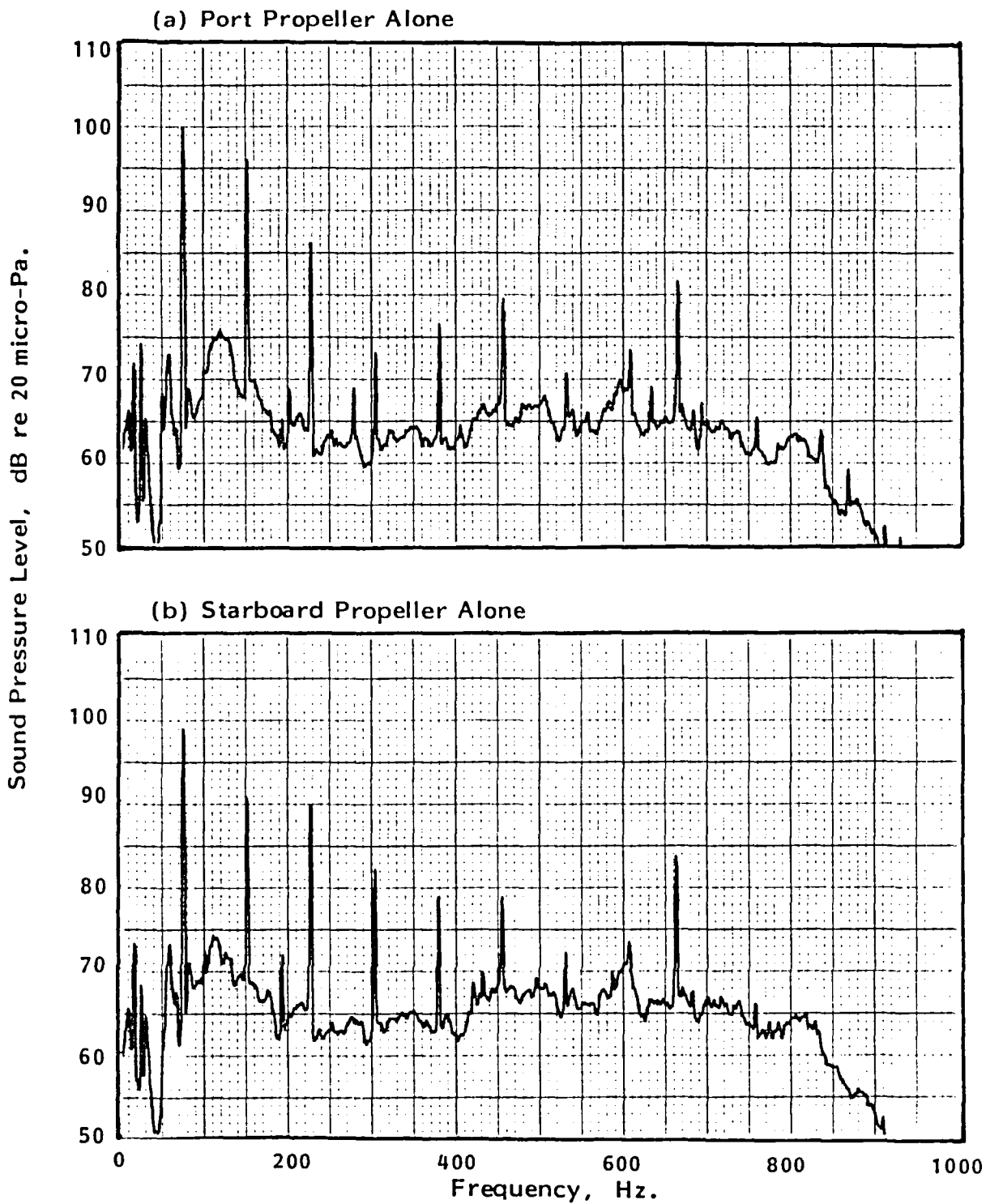

FIGURE 28. NARROWBAND SPECTRA OF CABIN SOUND PRESSURE LEVELS AT LOCATION 3; SINGLE-ENGINE OPERATION.

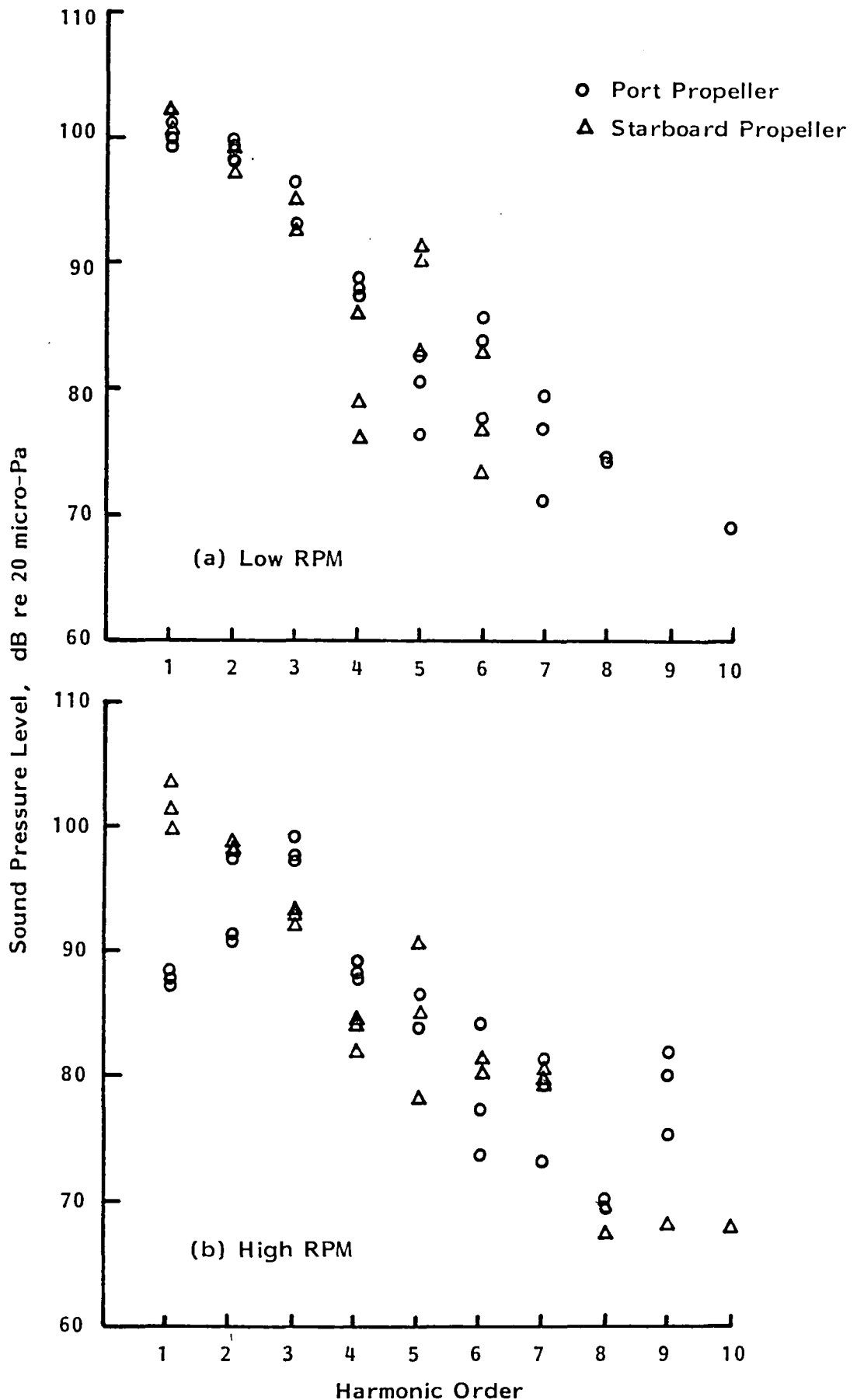

FIGURE 29. COMPARISON OF HARMONIC SOUND PRESSURE LEVELS MEASURED IN UNTREATED CABIN UNDER REPEATED FLIGHT CONDITIONS; PROPELLERS AT DIFFERENT RPM; MICROPHONE LOCATION 3.

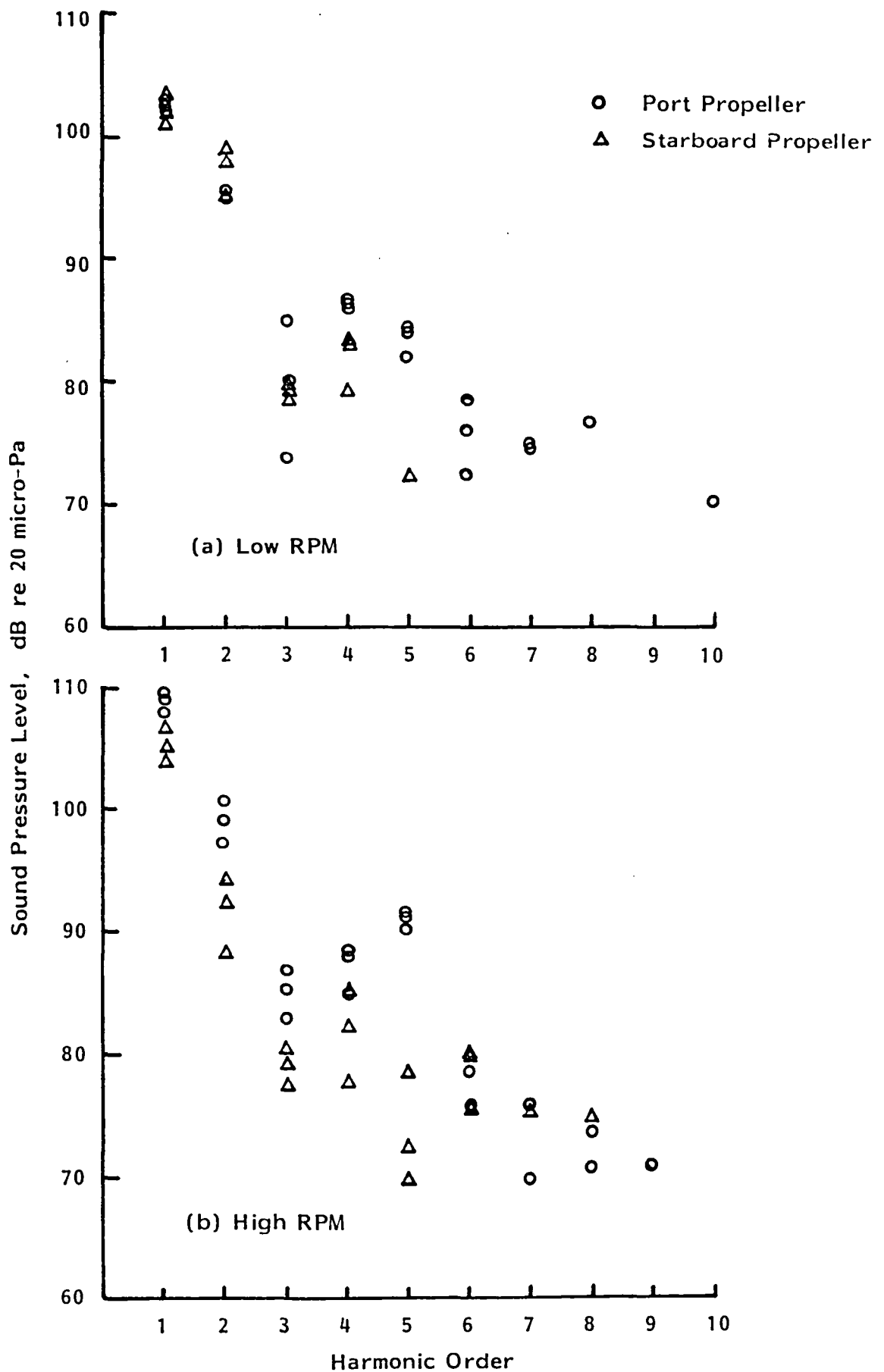

FIGURE 30. COMPARISON OF HARMONIC SOUND PRESSURE LEVELS MEASURED IN UNTREATED CABIN UNDER REPEATED FLIGHT CONDITIONS; PROPELLERS AT DIFFERENT RPM; MICROPHONE LOCATION 6.

The data in Figures 29 and 30 show that the range of sound pressure levels can vary from less than 1 dB to almost 13 dB, depending on harmonic order, microphone location and test condition. However, when averaged over harmonic orders and microphone locations the data variability is almost independent of propeller or test condition, the average range of sound pressure levels for an individual harmonic being 3.8 dB for the port propeller and 4.8 dB for the starboard. These values are similar to the average values for the exterior pressure field (see Section 3.2) although in that case the port propeller showed a slightly higher average variability than did the starboard. However, the standard deviation for the variability is higher for the interior sound pressure levels than for the exterior (typically 3.0 dB compared to 1.5 dB) indicating that the interior sound pressure levels have a wider scatter.

Consider now interior sound pressure levels associated with test conditions 5 through 8 and 13 through 16 for which both propellers were operated at the same rpm, but the relative phase between the propellers was set at four different nominal test conditions. Data associated with cabin microphones 3 and 6 are shown in Figures 31 and 32. The first observation is that the harmonic sound levels, for a given microphone and flight altitude, follow roughly the same general trend with harmonic order irrespective of phase setting. However, the data variability for an individual harmonic order is quite large, the average range of sound pressure levels for an individual harmonic being about 9.5 dB when averaged over all harmonics and both flight altitudes. The associated standard deviation is about 3.5 dB.

Such an evaluation, which is made without regard to relative phase setting, gives a general appreciation of the strong role played by propeller phase, but it is not necessarily a good way to judge

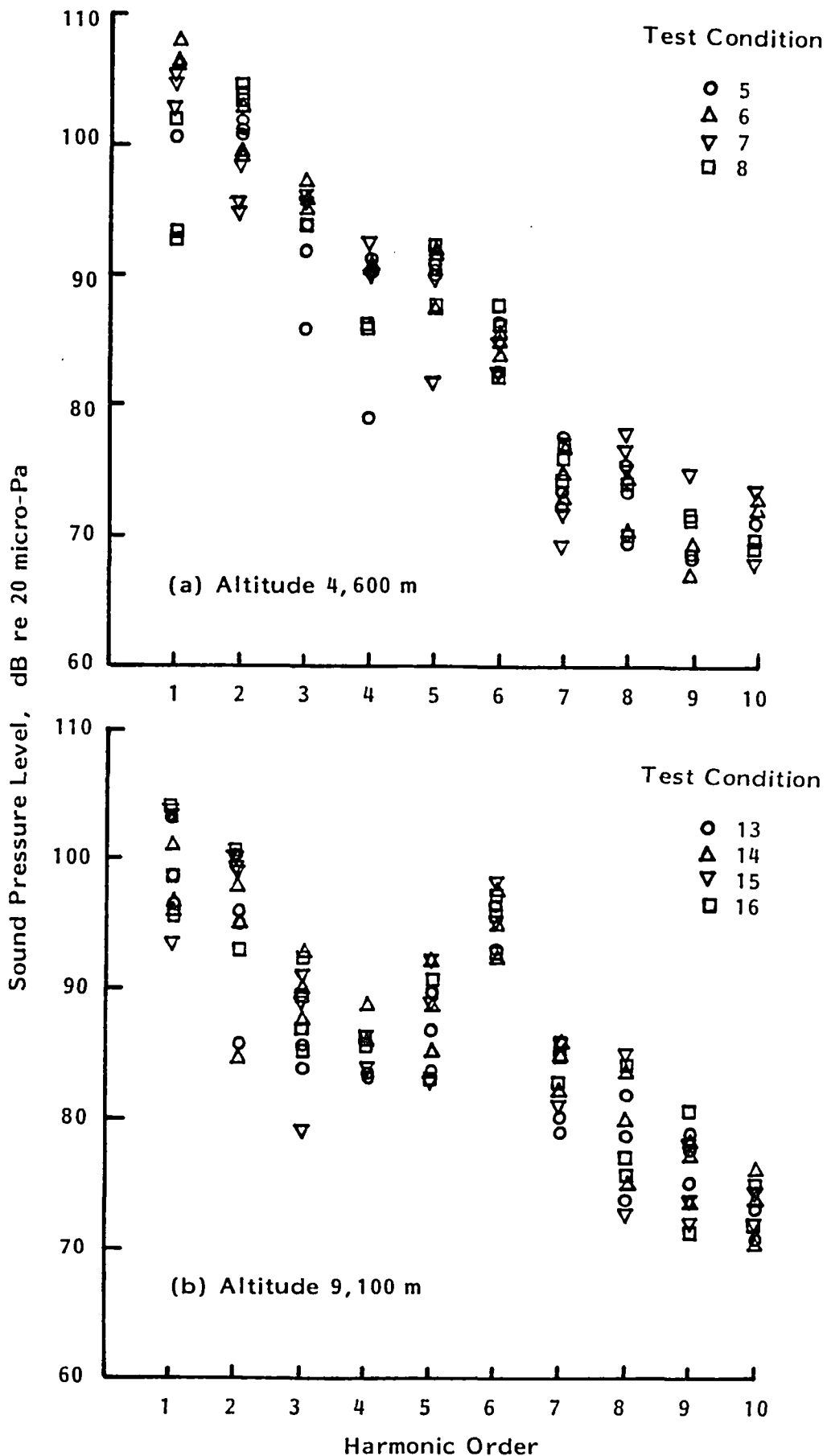

FIGURE 31. COMPARISON OF HARMONIC SOUND PRESSURE LEVELS MEASURED IN UNTREATED CABIN UNDER REPEATED FLIGHT CONDITIONS; PROPELLERS AT SAME RPM; MICROPHONE LOCATION 3

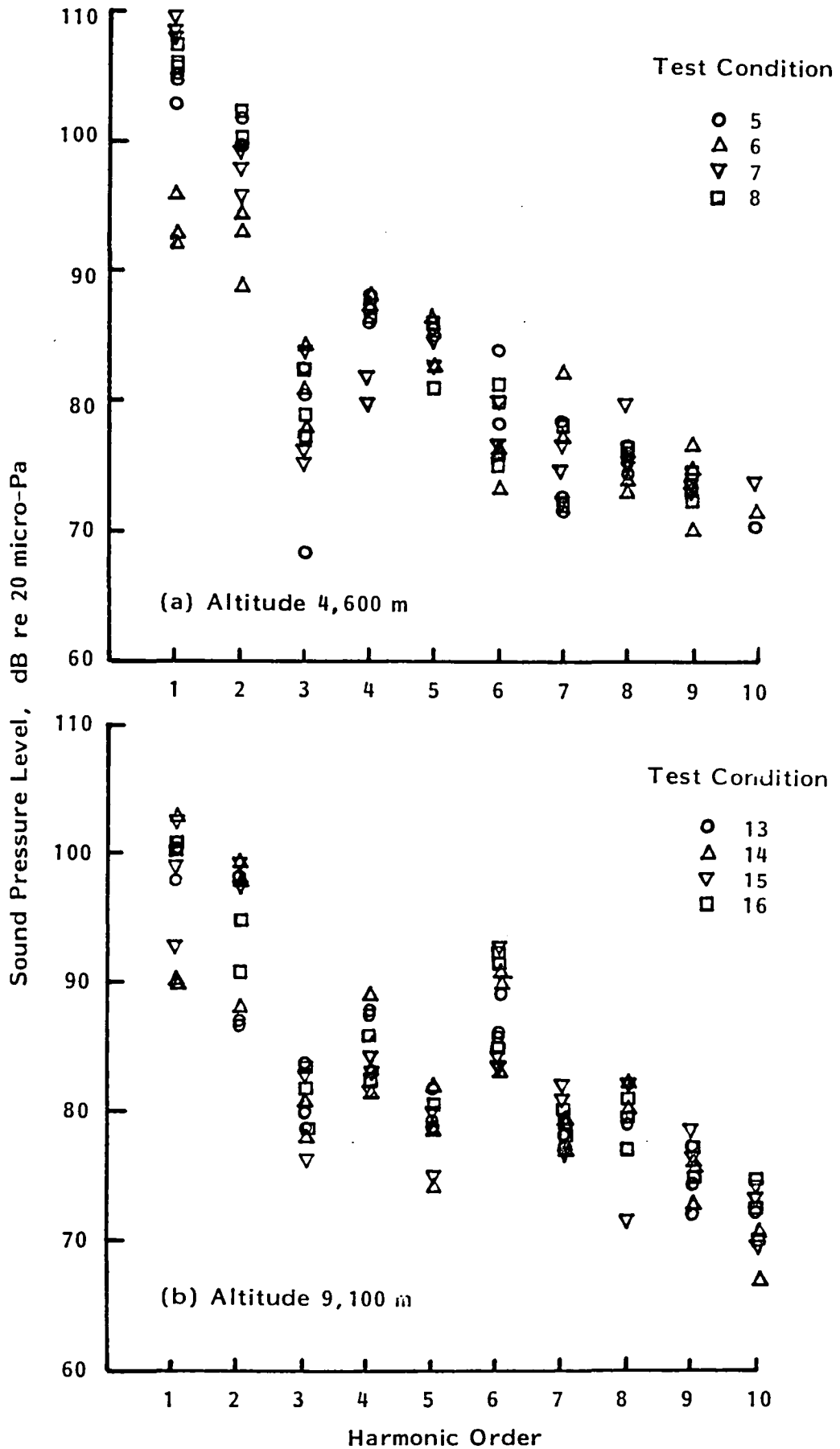

FIGURE 32. COMPARISON OF HARMONIC SOUND PRESSURE LEVELS MEASURED IN UNTREATED CABIN UNDER REPEATED FLIGHT CONDITIONS; PROPELLERS AT SAME RPM; MICROPHONE LOCATION 6

data repeatability. This can be performed more appropriately when (nominal) relative phase is maintained constant. Data for microphones 2, 3 and 6 have been analyzed in this manner; the data were averaged over three flights for each propeller relative phase setting and then the results were averaged over the four phase settings. Average variability for each harmonic and each microphone is plotted in Figure 33, where it is seen that, with few exceptions, the data variability is always less for test conditions 5 through 8 (test altitude of 4600 m) than for test conditions 13 through 16 (altitude of 9100m). When averaged over the three microphones and ten harmonics for test conditions 5 through 8, the data variability for any individual harmonic and propeller relative phase setting is 3.7 dB. The corresponding average variability for test conditions 13 through 16 is 5.5 dB. The standard deviation is 3.1 dB in each case.

Two comments can be made regarding the results obtained when analyzing the data separately for each nominal relative phase setting of the propellers. First, the data variability is similar to that observed when the propellers are operated at different rotational speeds. Secondly, the greater variability in the data for the higher airplane altitude is consistent with the propeller relative phase setting in Table 10, where it is seen that the relative phase setting was less repeatable at the higher altitude than at the lower altitude.

One factor which could affect the data variability is the resolution bandwidth used in the data reduction process. In early work on an Aero Commander airplane with reciprocating engines, it was noted [15] that, since propeller blade passage tones are not perfect sine waves but in fact have finite bandwidths, it is desirable to use a resolution bandwidth that is at least as wide as the tones being analyzed. For that particular test, a bandwidth of 2

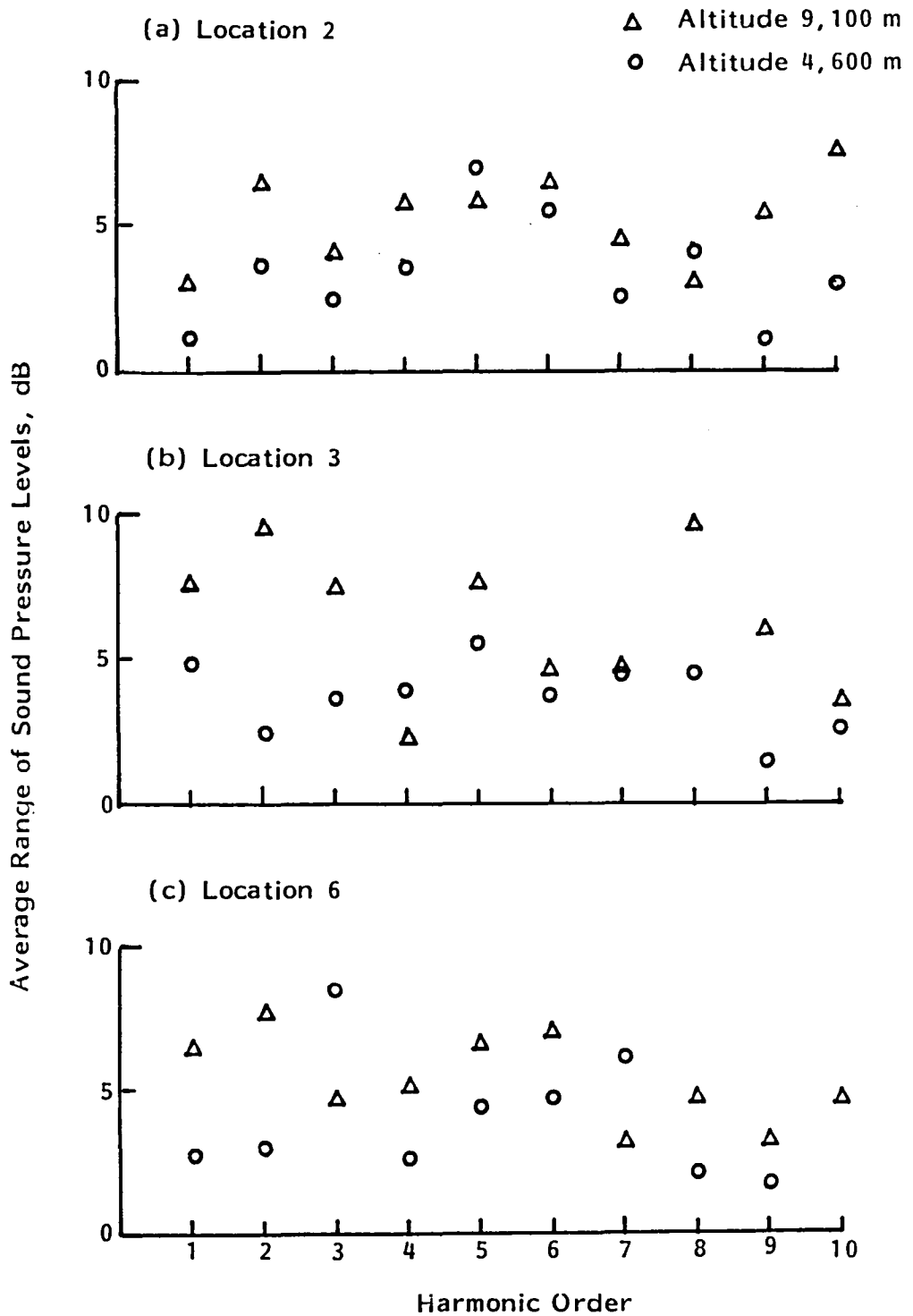

FIGURE 33. RANGE OF HARMONIC SOUND PRESSURE LEVELS MEASURED IN UNTREATED CABIN FOR FLIGHTS 1 THROUGH 3. PROPELLERS AT SAME RPM; DATA AVERAGED OVER FOUR NOMINAL SYNCHROPHASE SETTINGS.

to 4 Hz appeared to be a good compromise. A second item of consideration is the speed stability of the propellers; if the speed drifts by too large an amount, the harmonic frequency could drift from one spectral line (when FFT data reduction methods are being used) to an adjoining spectral line resulting in a lower effective spectral level following averaging over the recorded data time sample.

In the present case, the bandwidth was dictated to some extent by the need to distinguish between port and starboard propeller contributions when the propellers were operated at different rpm. As a consequence, the frequency resolution was 0.5 Hz for harmonics of order 1 through 5 (frequencies below 400 Hz) and 1.0 Hz for harmonics 6 through 10 (frequencies between 400 and 800 Hz). The associated half-power bandwidths for the effective filters are approximately 0.9 and 1.7 Hz, respectively.

The possibility that filter bandwidth might be influencing the data was explored by analyzing time histories of harmonic sound pressure level signals obtained from the output of the SD 360 narrowband analyzer. The analysis was performed first for data associated with test conditions where the two propellers were operated at different rotational speeds. Data from such an analysis is shown in Figure 34 for seven harmonics. It is seen that the sound levels for the lowest order harmonics are very stable as a function of time, but as harmonic order increases the fluctuations in the data also increase in magnitude. However, in spite of these fluctuations, there is no general upward or downward trend in sound level which would be associated with a drift in harmonic frequency into or out of the spectral band. The interpretation placed on the data in Figure 34 is that any measured

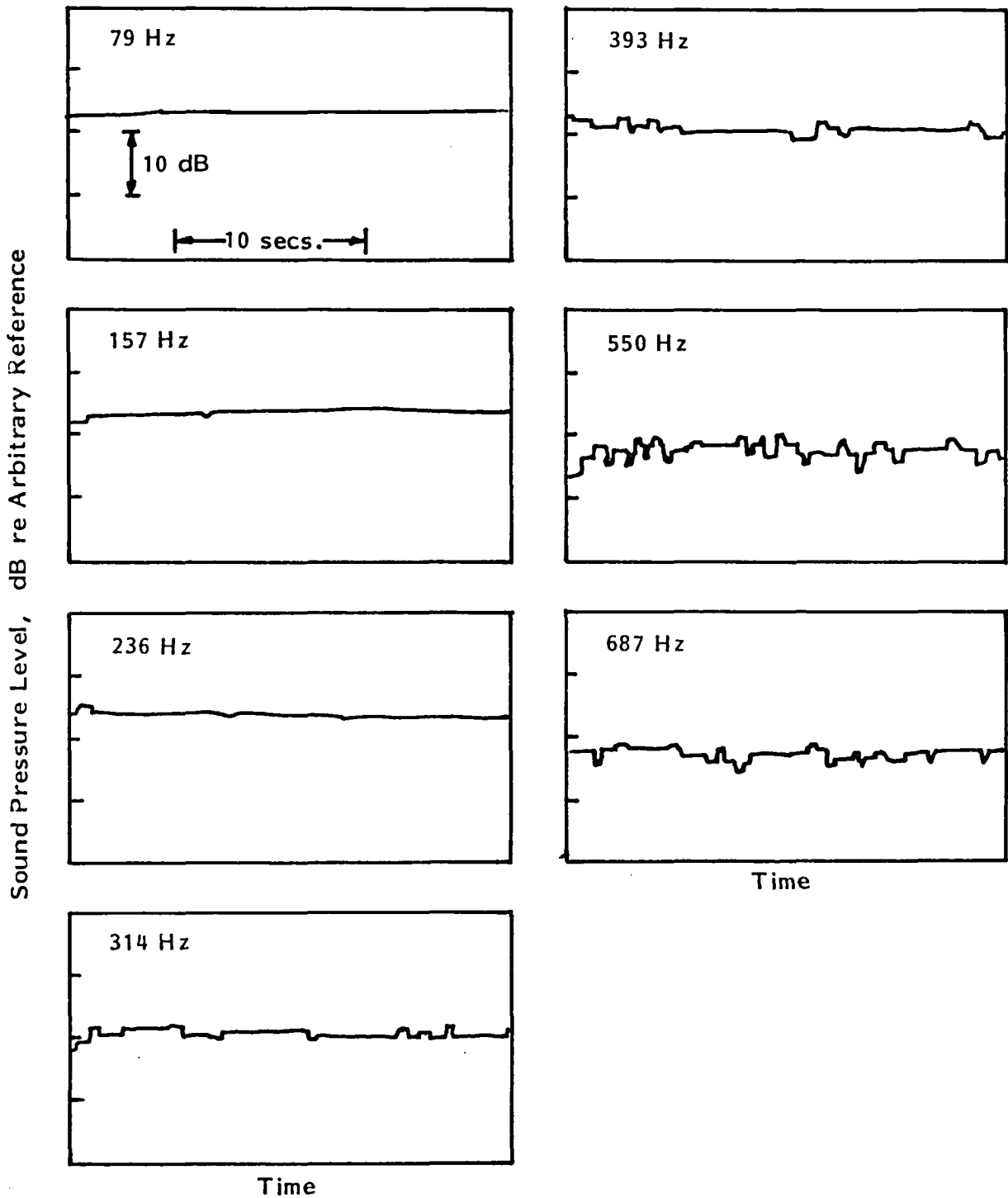

FIGURE 34. TIME HISTORIES OF HARMONIC SOUND PRESSURE LEVELS IN CABIN; TWO ENGINES OPERATING AT DIFFERENT RPM (CONDITION 9)

fluctuations in sound pressure level are actual fluctuations at the observation point and are not artifacts of the data reduction process and filter bandwidth.

The analysis was then repeated for data associated with test conditions where the two propellers were operated at the same rpm. Typical data for such conditions are shown in Figure 35. The time histories show data irregularity patterns which are similar to those in Figure 34, but now there are underlying trends of increasing or decreasing sound level during the 30-second recording time. Since it has been determined, by arguments such as those in the preceding paragraph, that the data reduction methods are not introducing these general trends, the results in Figure 35 are interpreted as indicating the influence of slight drifts in relative phase between the two propellers.

4.3 One-Third Octave Band Spectra

The narrowband spectra are of interest mainly because they provide data on the harmonics of the blade passage frequency. However, it is possible that the broadband components in the spectra will be of interest also, for example when evaluating the contributions from the turbulent boundary layer. Consequently, interior sound pressure levels from flight #3 were reduced in terms of one-third octave bands, as well as narrowband spectra. The results of the one-third octave band analysis are given in Appendix D for future reference; the data are not discussed in detail in this report.

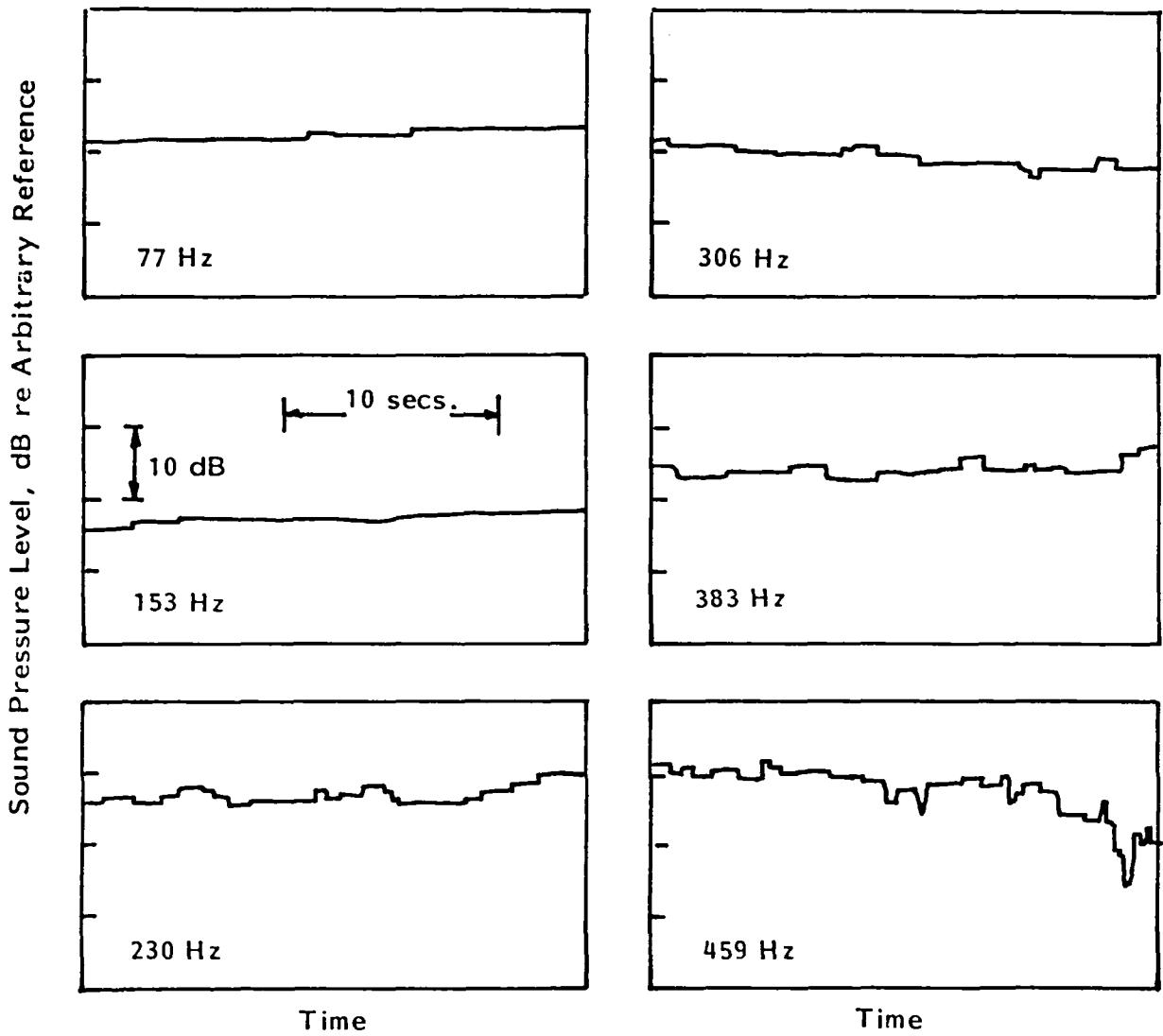

FIGURE 35. TIME HISTORIES OF HARMONIC SOUND PRESSURE LEVELS IN CABIN; TWO ENGINES OPERATING AT SAME RPM (CONDITION 8)

5.0 SOUND LEVELS IN TREATED CABIN

After flight #3, the interior surfaces of the cabin sidewall and ceiling were covered with fiberglass batts, as described in Section 2.4. There was no acoustic treatment on the cabin floor, but a heavy, flexible bulkhead was installed between the cockpit and the cabin. Sound pressure levels in the treated cabin were then measured during flight #4. Unfortunately, a malfunction of the propeller synchrophaser limited the number of test conditions for that flight. Also, as there was only one flight in the treated configuration, it was not possible to explore data variability for that configuration. Interior sound pressure levels measured in the cabin during flight #4 are given in Appendices C and F, with Appendix C containing harmonic sound pressure levels and Appendix F one-third octave band spectra.

A general assessment of the noise reduction provided by the fiberglass treatment can be obtained from a direct comparison of narrowband sound pressure spectra measured in the cabin during flights 3 (untreated) and 4 (treated). Comparisons of this type are given in Figures 36 and 37. The difference in spectrum level at a given frequency is a measure of the insertion loss provided by the treatment (assuming the exterior sound field is constant).

The first observation regarding the spectra in Figures 36 and 37 is that the sound pressure levels at microphone location 1, in the cockpit, are essentially unaffected by the cabin treatment. It should be remembered that, in the treatment interior the cockpit is isolated from the cabin by the flexible bulkhead. Furthermore, comparing spectra in Figure 36, it is seen that the sound pressure levels in the untreated cabin are similar in value at locations 1

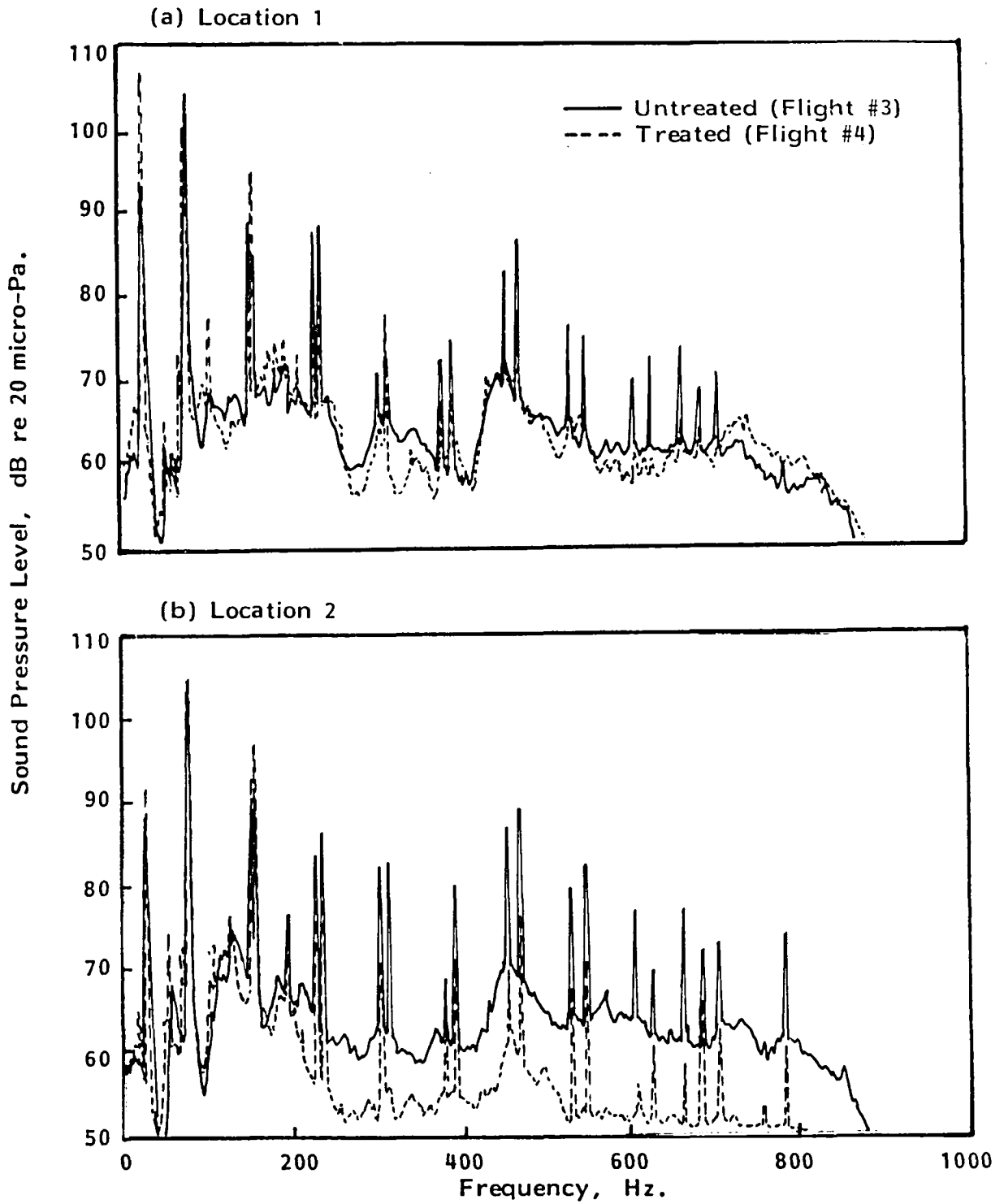

FIGURE 36. EFFECT OF FIBERGLASS TREATMENT ON CABIN NARROWBAND SOUND PRESSURE LEVEL SPECTRA: ALTITUDE 9,100 m.

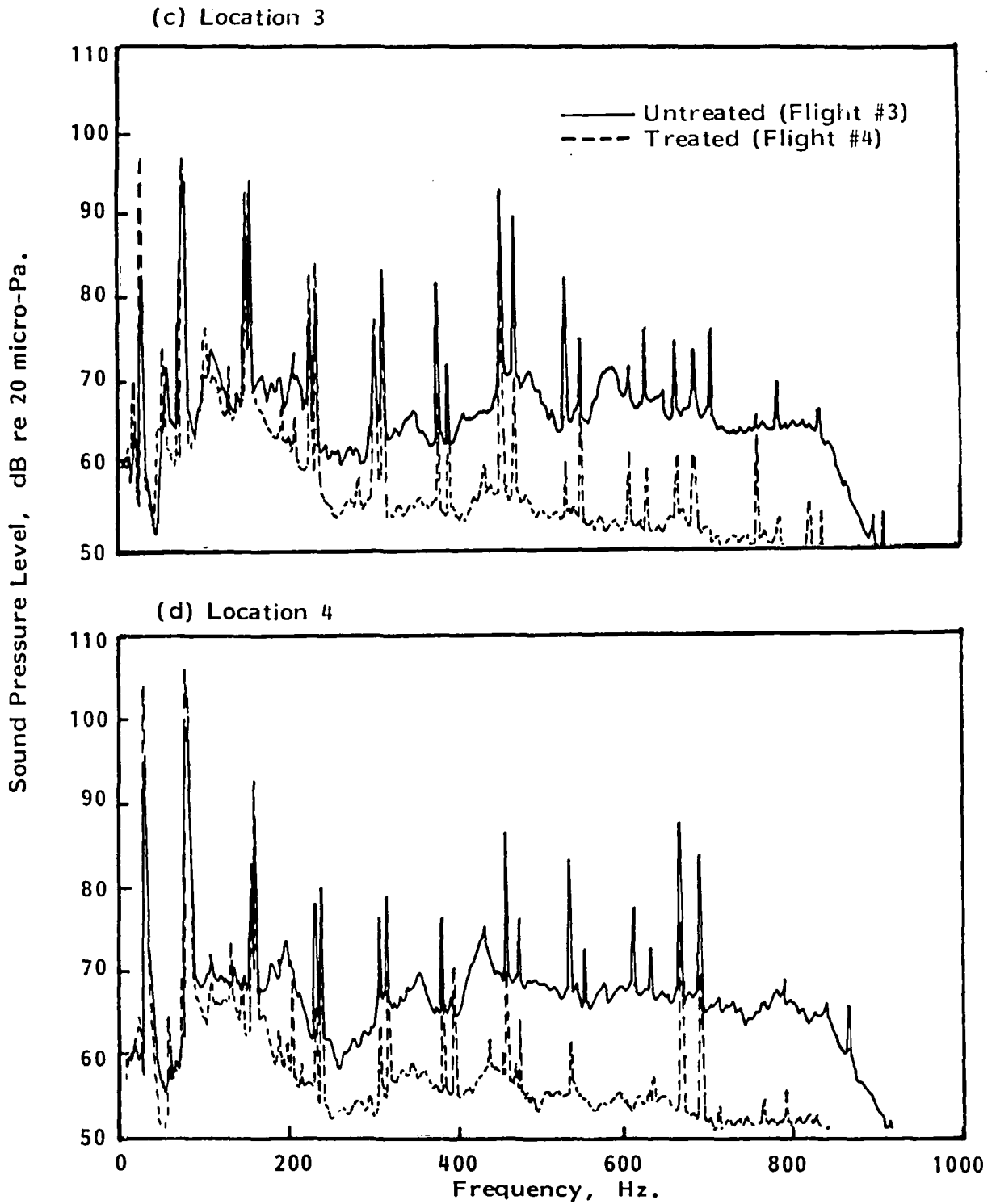

FIGURE 36. CONTINUED

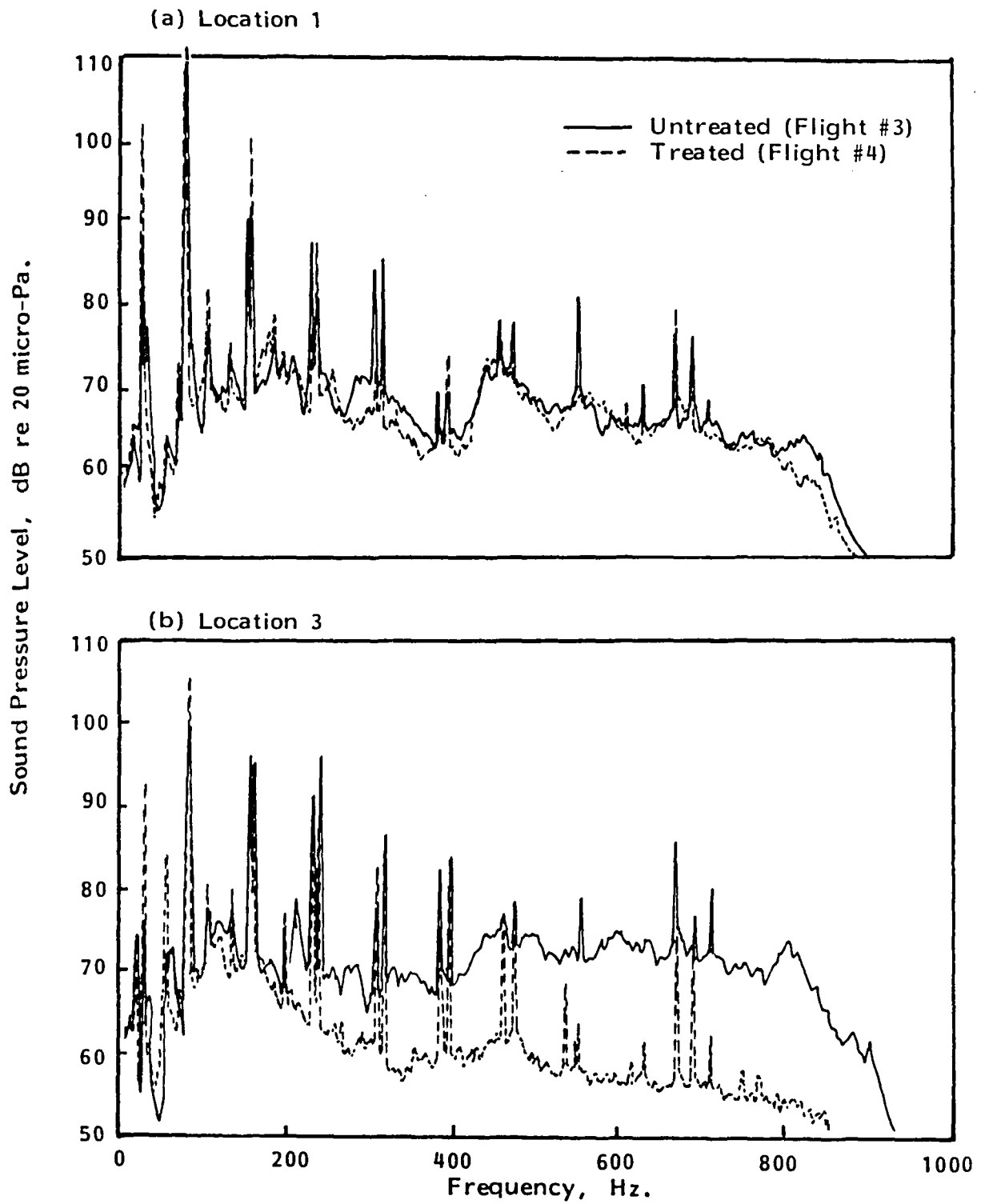

FIGURE 37. EFFECT OF FIBERGLASS TREATMENT ON CABIN NARROWBAND SOUND PRESSURE LEVEL SPECTRA: ALTITUDE 4,600 m.

and 2, but in the treated cabin the sound levels are generally higher at location 1 than at location 2. These observations suggest that the sound pressure levels in the cockpit are dominated by airborne transmission through the cockpit windows and structure, or by structureborne transmission with subsequent radiation into the cockpit. The sound pressure levels in the cockpit do not appear to be dominated by airborne transmission via the cabin.

When acoustic spectra are compared for microphone locations in the cabin it is found that the insertion loss provided by the fiberglass treatment increases with frequency. For a given frequency, the insertion loss at location 2 appears to be lower than that at either location 3 or 4. The reasons for the reduced effect at the forward location are not readily apparent since the treatment was applied uniformly over the cabin sidewall and roof. There are structural differences, location 2 being close to the emergency hatch. Also, location 2 is closest to the cockpit and thus could be influenced by sound leaking around the flexible bulkhead. Both of these factors could have more of an influence on the sound levels at location 2 than at other locations in the cabin.

A more detailed evaluation of the insertion loss provided by the treatment is presented in Section 6.3 in terms of harmonic components and one-third octave band spectra.

6.0 DISCUSSION

The main objective of this report is to present data for possible future analysis. To this end an attempt has been made to provide as much detail as possible regarding the data acquisition and reduction methods, as well as the narrowband and one-third octave band acoustic data. However, some discussion can be provided within the present scope of work. The discussion is directed towards three of the more important aspects of the results--the effect of cabin pressurization, the difference between exterior and interior sound pressure levels, and the influence of the fiberglass treatment on cabin sound pressure levels. It should be emphasized that the discussion is based on only a small percentage of the total amount of data acquired during the test program and that, as a consequence, the conclusions should be regarded as only tentative. It is hoped that the comments and interpretations of the results will stimulate a more detailed analysis of the data presented in the appendices of this report.

6.1 Cabin Pressurization

The influence of cabin pressurization on cabin sound pressure levels was investigated during flight at a nominal altitude of 3,000 m (10,000 ft). Measurements were made first with the cabin unpressurized; the cabin was then pressurized to a differential of about 26 kN/sq m (3.7 psf) and the measurements repeated.

The effect of cabin pressurization on interior sound levels can be seen in Figure 38, the measurements being made at an airplane altitude of 3,000 m (10,000 ft). While it is difficult to identify any particular trend in the sound levels at propeller harmonics, certain other characteristics can be seen in the spectra. Some of these characteristics are identified by arrows in the

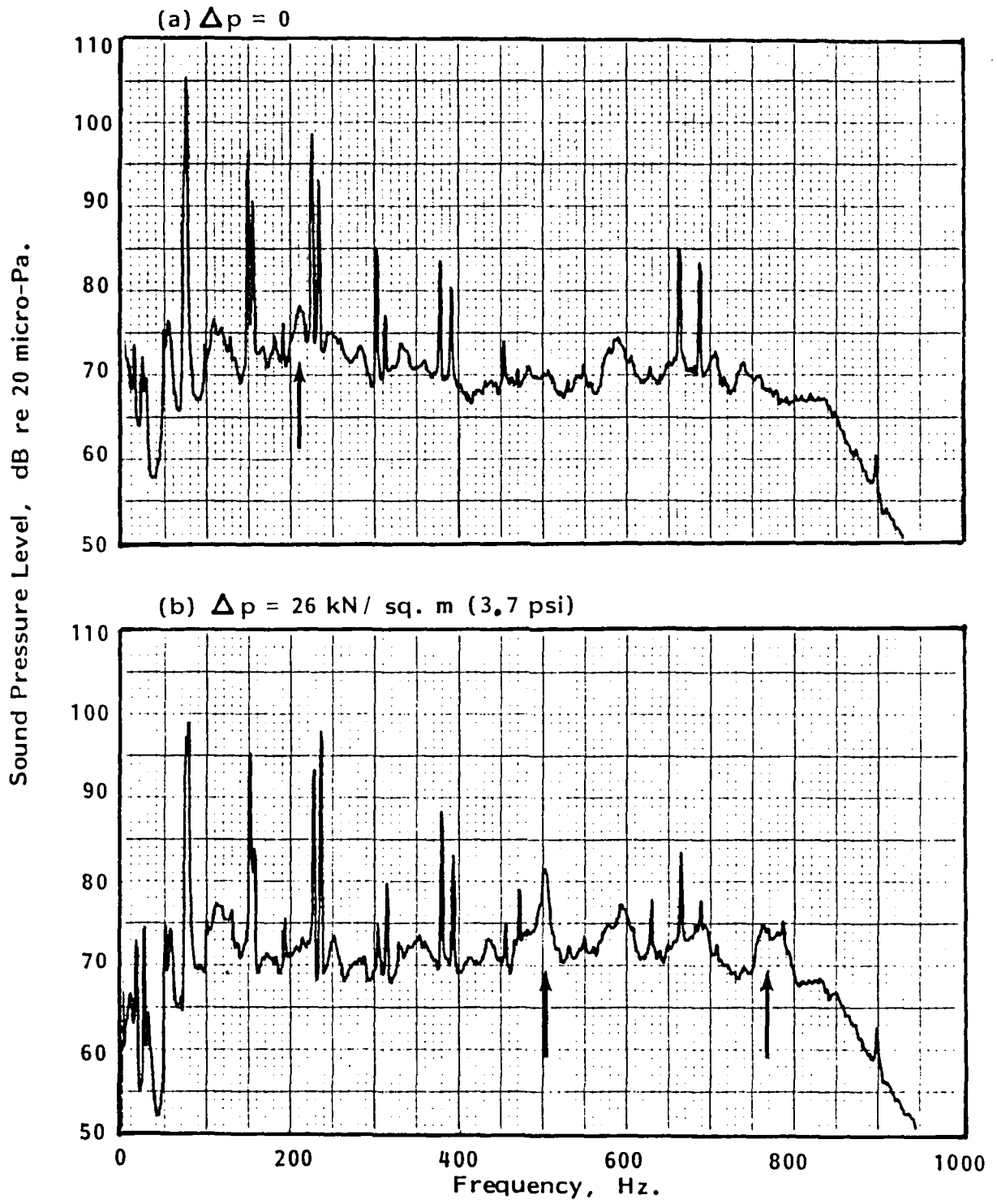

FIGURE 38. NARROWBAND SPECTRA OF CABIN SOUND PRESSURE LEVELS AT LOCATION 3; EFFECT OF CABIN PRESSURE DIFFERENTIAL. (AIRPLANE ALTITUDE 3,000 m)

figure. In the case of Figure 38(a) the arrow indicates a frequency region in which the sound pressure levels decrease as the pressure differential increases. Conversely, the arrows in Figure 38(b) show frequency regimes where the sound pressure levels increase with pressure differential.

There are at least two phenomena that are influencing the results. First, increasing the pressure differential will introduce in-plane stresses in the fuselage skin. These stresses will increase the effective stiffness of the structure and shift some of the resonances to higher frequencies. This could influence the response of the structure to the exterior pressure field and the acoustic radiation into the cabin. Secondly, for a given level of vibration in the structure, the radiated acoustic pressures will be proportional to the gas density in the receiving volume. In the present case, assuming a negligible change in temperature in the cabin, it is predicted that the sound pressure levels in the cabin would increase by 3.3 dB when the cabin pressure is increased (and the vibration of the structure is assumed constant).

The effect of pressure differential can be studied in more detail by considering the changes in harmonic sound pressure level or one-third octave band level when the pressure differential is increased. This is achieved by determining the difference between the sound levels associated with conditions 1 and 4 or between conditions 2 and 3. Data in this format are presented in Appendix G for microphones at locations 3 and 6; the same data are plotted in Figure 39 through 44. It should be noted that the results have not been adjusted for changes in the measured exterior pressure levels from condition to condition. The data in the figures refer to flights 3 (untreated cabin) and 4 (treated cabin), the flights being identified in the figures by the symbols F3 and F4

MIC #3. PORT ENGINE COMPONENTS.

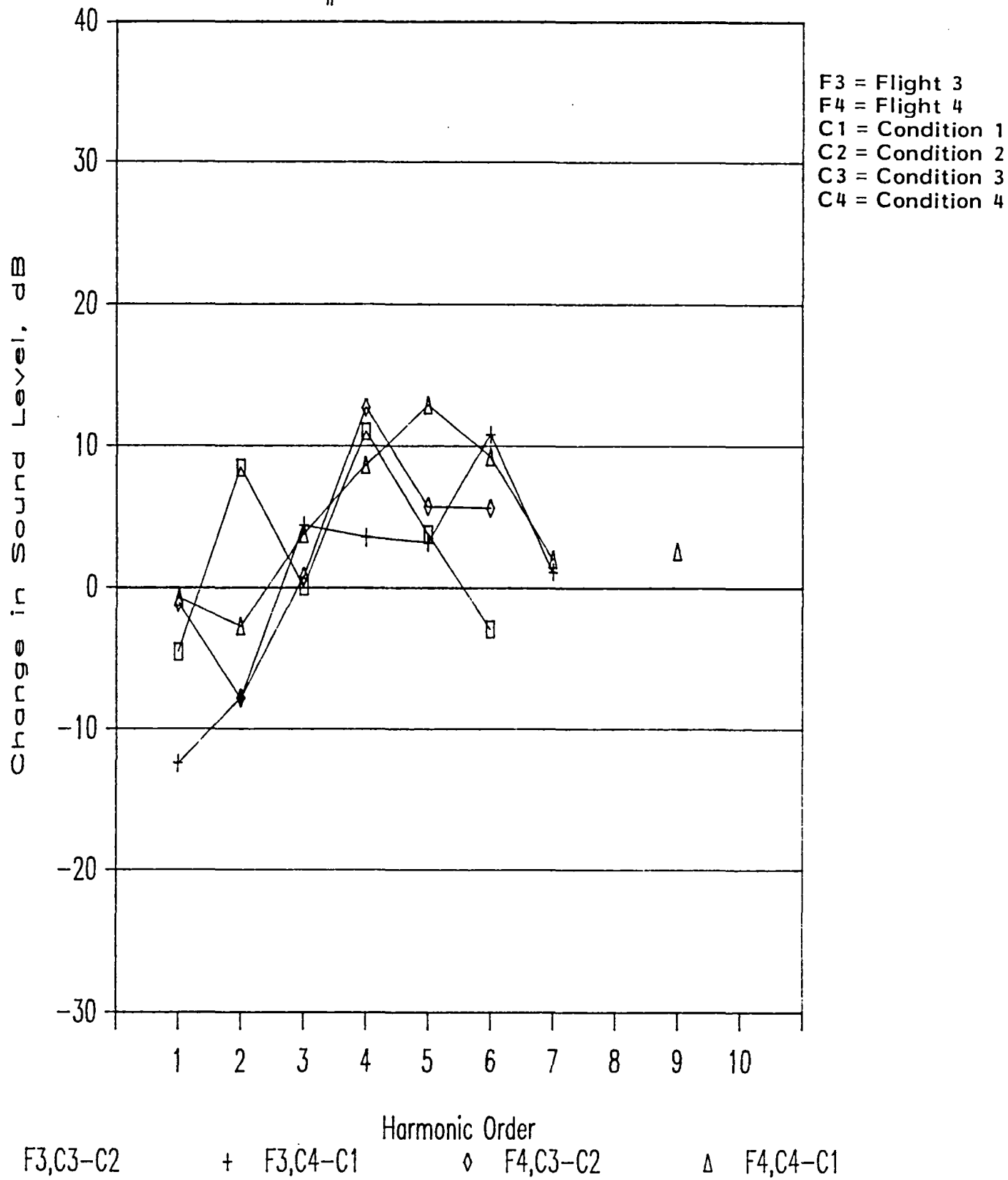

FIGURE 39. CHANGE IN HARMONIC SOUND PRESSURE LEVEL IN CABIN DUE TO CABIN PRESSURE DIFFERENTIAL. MICROPHONE LOCATION 3; PORT PROPELLER COMPONENT, HIGH AND LOW RPM.

MIC #3. STARBOARD ENGINE COMPONENTS.

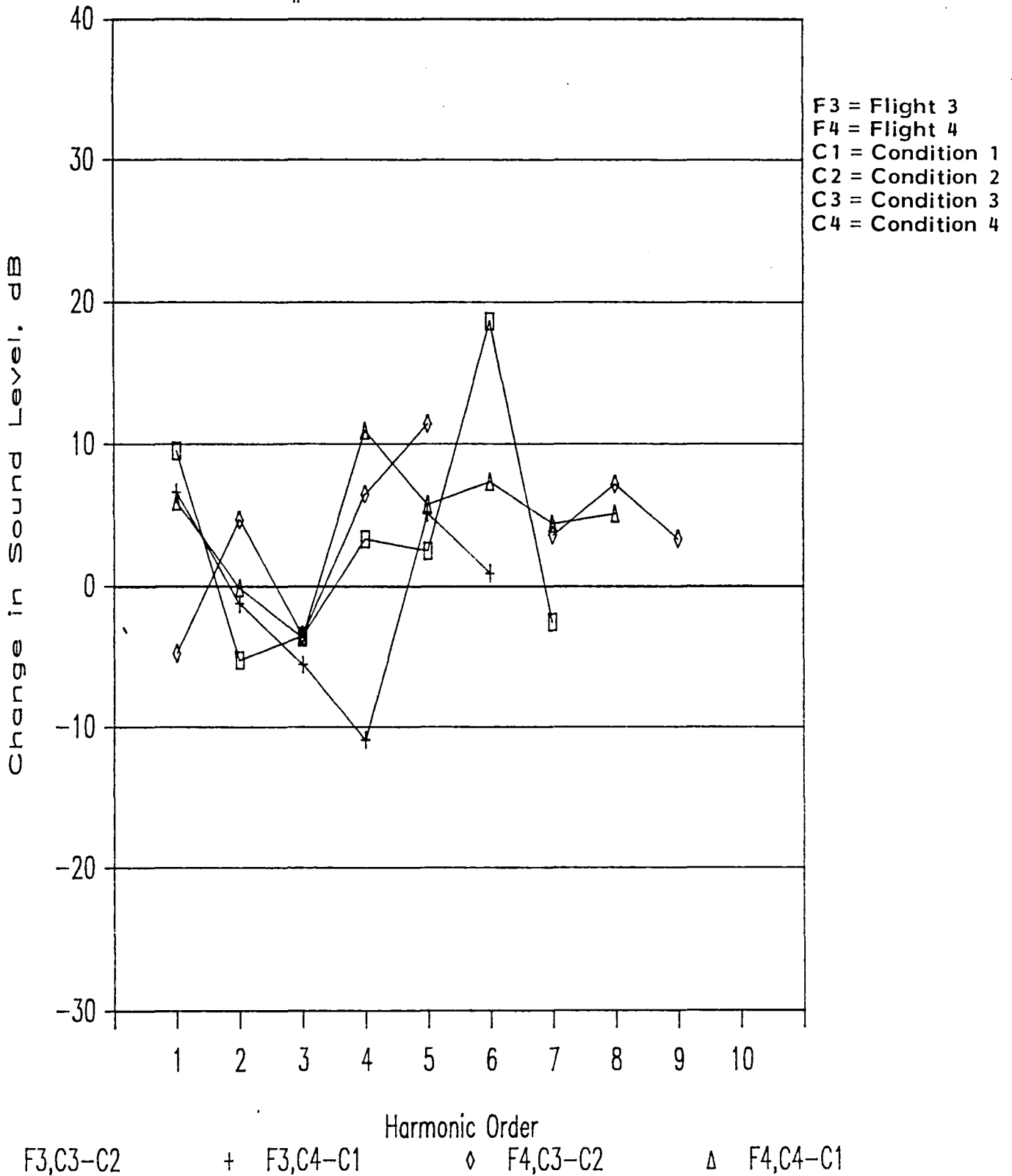

FIGURE 40. CHANGE IN HARMONIC SOUND PRESSURE LEVEL IN CABIN DUE TO CABIN PRESSURE DIFFERENTIAL. MICROPHONE LOCATION 3; STARBOARD PROPELLER COMPONENT, HIGH AND LOW RPM.

MIC #6. PORT ENGINE COMPONENTS.

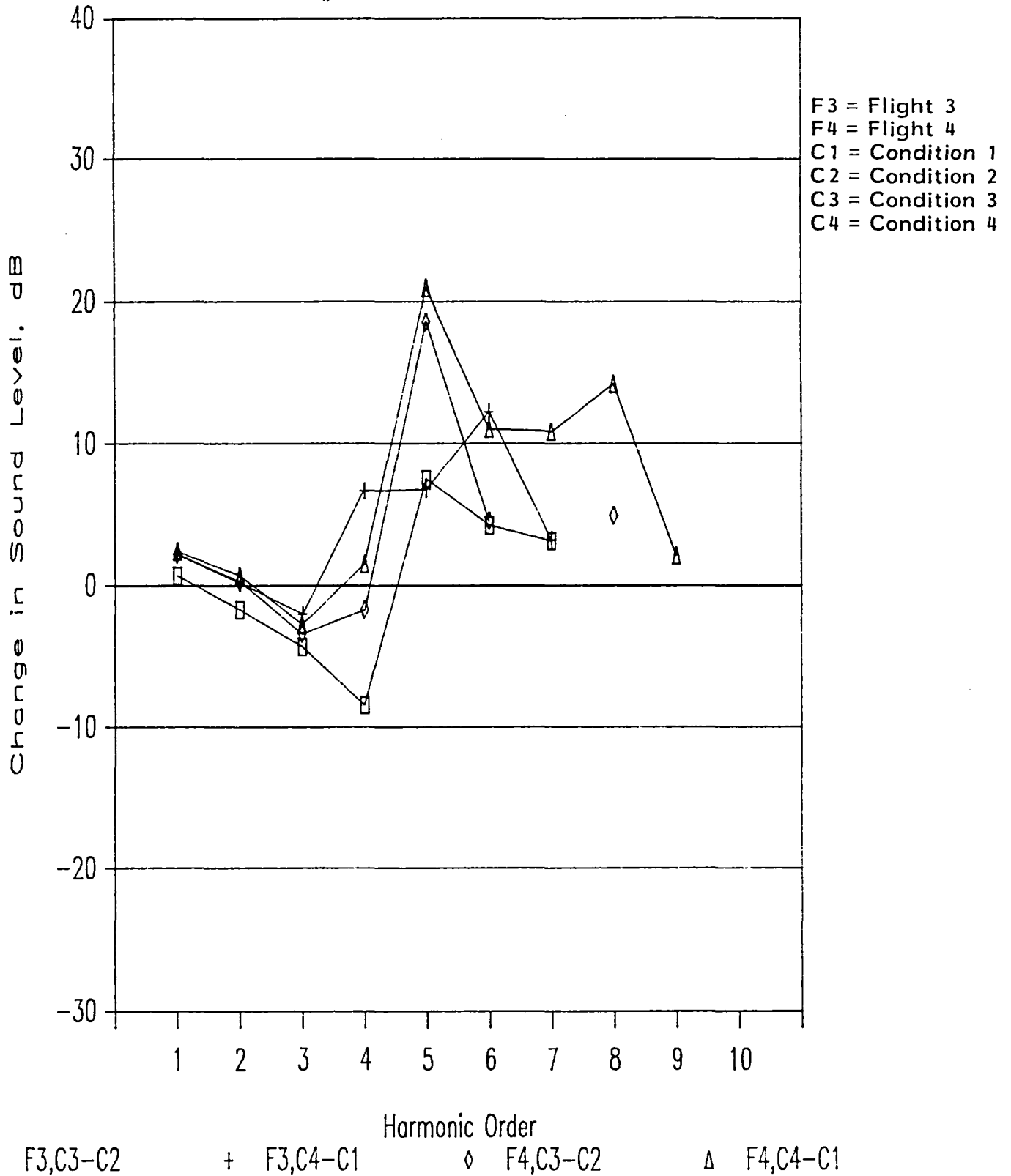

FIGURE 41. CHANGE IN HARMONIC SOUND PRESSURE LEVEL IN CABIN DUE TO CABIN PRESSURE DIFFERENTIAL. MICROPHONE LOCATION 6; PORT PROPELLER COMPONENT, HIGH AND LOW RPM.

MIC #6. STARBOARD ENGINE COMPONENTS.

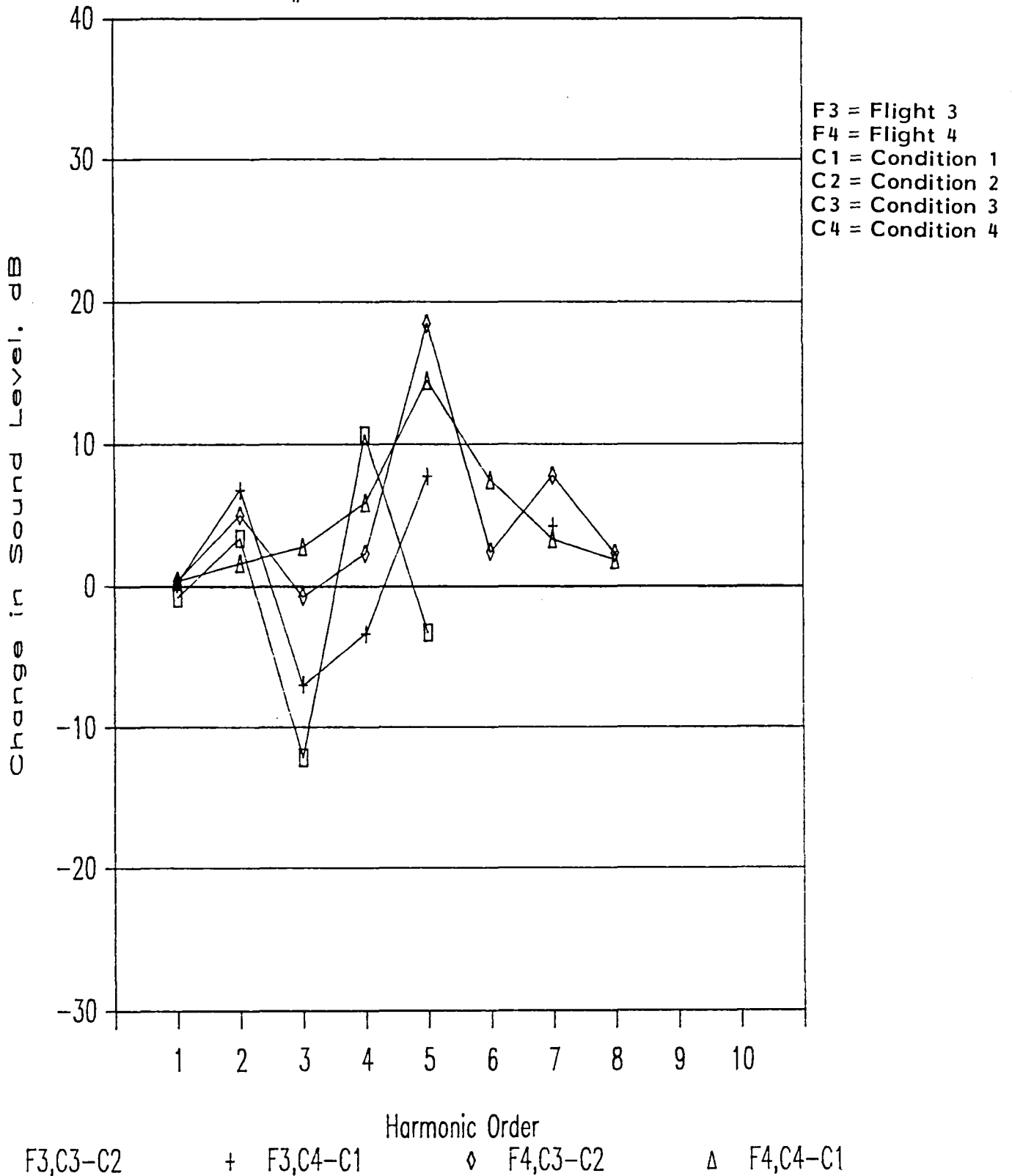

FIGURE 42. CHANGE IN HARMONIC SOUND PRESSURE LEVEL IN CABIN DUE TO CABIN PRESSURE DIFFERENTIAL. MICROPHONE LOCATION 6; STARBOARD PROPELLER COMPONENT, HIGH AND LOW RPM.

CABIN MIC #3. PRESSURIZATION EFFECT.

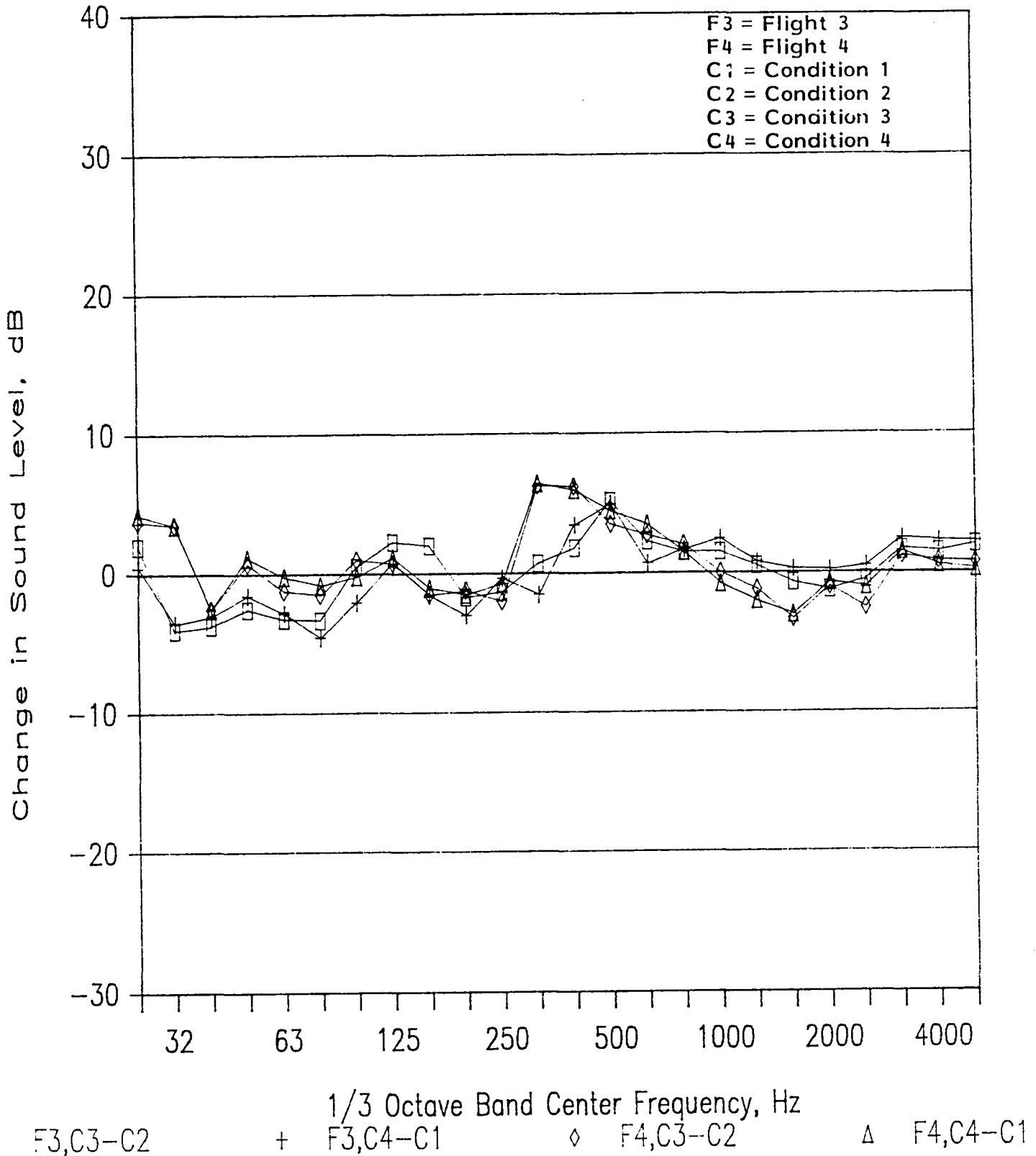

FIGURE 43. CHANGE IN ONE-THIRD OCTAVE BAND SOUND PRESSURE LEVEL IN CABIN DUE TO CHANGE IN CABIN PRESSURE DIFFERENTIAL; MICROPHONE LOCATION 3.

CABIN MIC #6. PRESSURIZATION EFFECT.

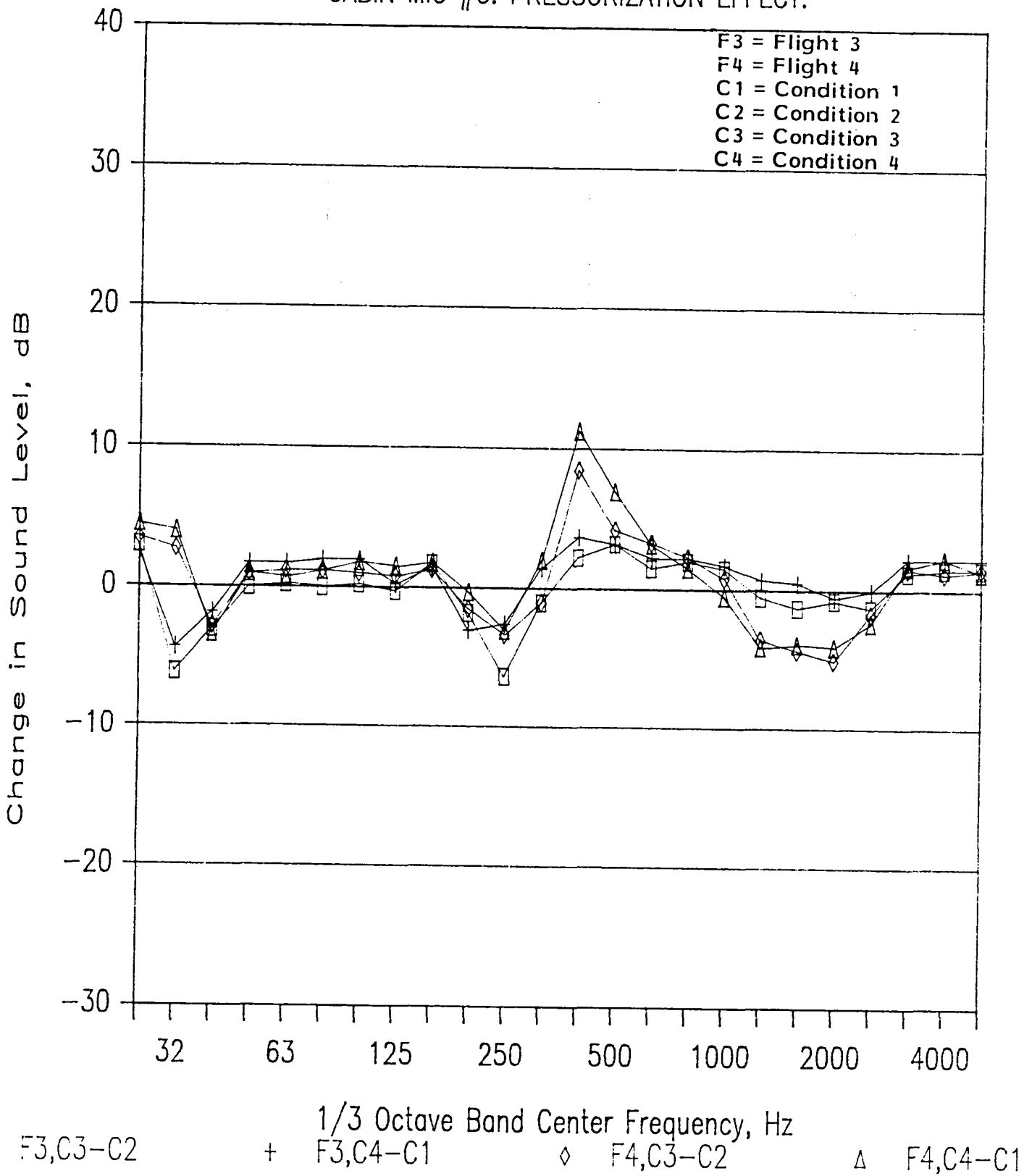

FIGURE 44. CHANGE IN ONE-THIRD OCTAVE BAND SOUND PRESSURE LEVEL IN CABIN DUE TO CHANGE IN CABIN PRESSURE DIFFERENTIAL; MICROPHONE LOCATION 6.

respectively. Conditions 1 through 4 are identified in the figure legends by symbols C1 through C4.

Considering first the data for the harmonics, Figures 39 through 42 show quite a large amount of data scatter. It should be remembered with respect to these figures that the data are plotted in terms of harmonic order rather than frequency; a given harmonic for test conditions 1 and 4 occurs at a different frequency than is the case for conditions 2 and 3. Furthermore, the data in the figures refer to both untreated and treated interiors. Finally, the data represent only a small fraction of the total data recorded and listed in Appendices B and C. The intent here is to show general trends rather than perform a detailed analysis. These trends show that, as cabin pressure differential increases, the cabin sound level for the first propeller harmonic increases by a small amount (on the average, less than 5 dB). The sound levels for the second and third harmonics decrease by a small amount, and sound levels for the fourth harmonic increase slightly. The largest increases in sound level occur for the fifth and sixth harmonics, where changes as high as 29 dB are observed and the average increase is 5 to 13 dB (where the averaging is performed over all test conditions and both flights for a given propeller and microphone).

Turning to the one-third octave band spectra shown in Figures 43 and 44, it is seen that there are alternating frequency ranges of increasing and decreasing sound pressure level. However, in very few frequency bands does the sound level increase exceed the 3.3 dB value predicted on the basis of the change of air density in the cabin. The exceptions are essentially the one-third octave bands centered at 315, 400 and 500 Hz. These are the frequency bands containing the fourth, fifth and sixth harmonics of the propeller blade passage frequency. This means that, if the effect

of cabin air density is removed from the data, the increased stresses in the structure due to cabin pressure differential have the effect of reducing noise levels in the cabin at most frequencies.

6.2 Sidewall Noise Reduction

By definition, the noise reduction provided by the fuselage structure and cabin treatment is the difference between the exterior and interior sound pressure levels. This quantity can be measured fairly readily when the exterior and interior sound pressure levels are spatially uniform. However, such a condition is not satisfied in the present environment; the situation is further complicated by the presence of only one exterior microphone on each side of the fuselage. As a consequence, the term "noise reduction" is used here in the loose sense of the difference between sound pressure levels measured at a single exterior microphone and a single interior microphone. Furthermore, in the present analysis the interior microphones are restricted to locations 3 and 6, and the data are restricted to flights 3 and 4.

Noise reductions measured in the untreated cabin at harmonics of the propeller blade passage frequency are listed in Appendix H; corresponding data for the treated cabin are given in Appendix I. Selected data, representative of the different flight test conditions, are shown in Figures 45 through 48. The results for the two microphone locations tend to be different in character. At location 6 the noise reduction in the untreated cabin first increases with harmonic order (or frequency) and then is essentially independent of harmonic order at higher orders. In the treated cabin the noise reduction increases markedly as harmonic order increases. In contrast, at microphone location 3 the data

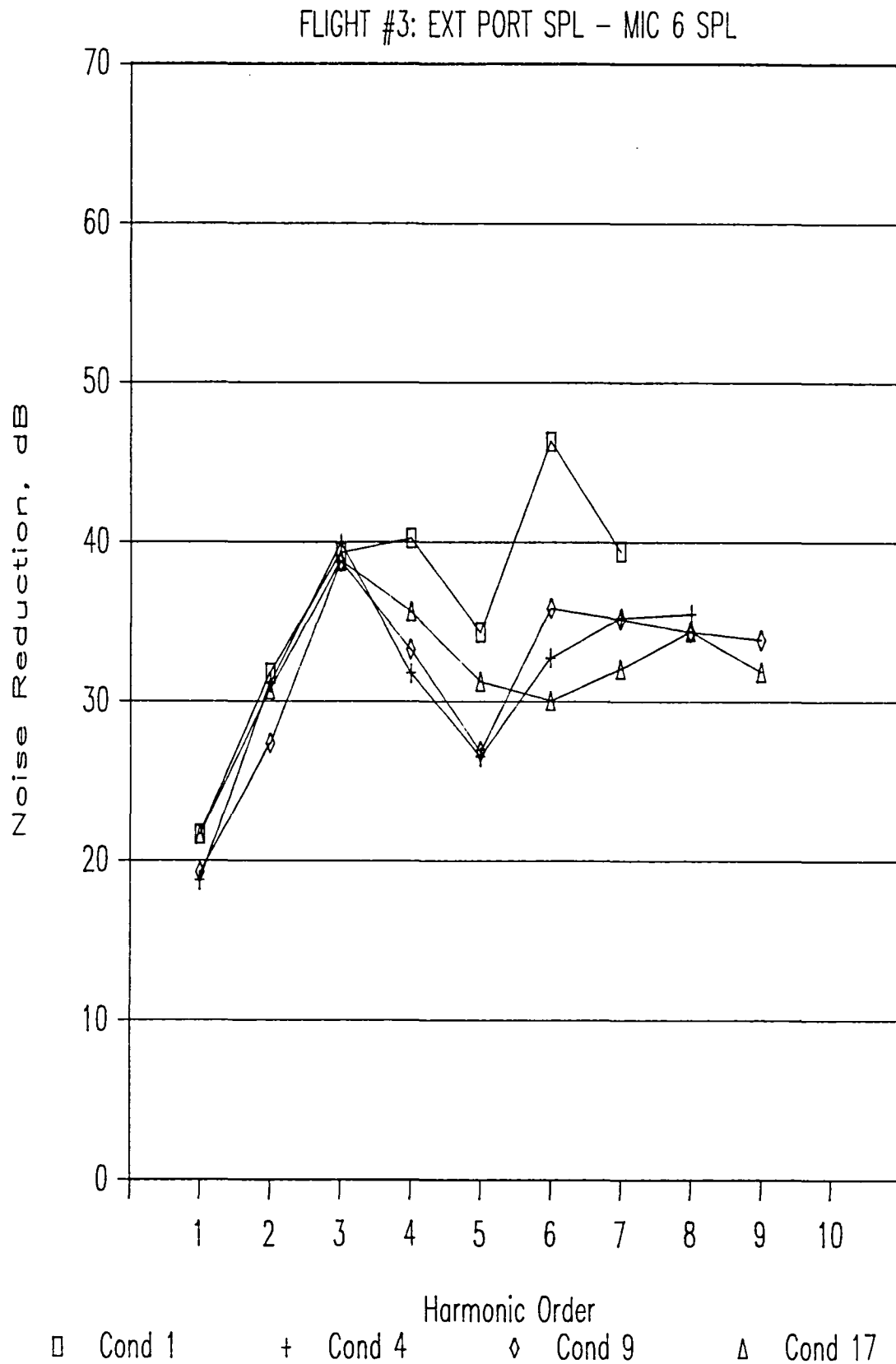

FIGURE 45. HARMONIC NOISE REDUCTION FOR UNTREATED CABIN: FLIGHT 3, EXTERIOR PORT MICROPHONE, INTERIOR MICROPHONE LOCATION 6.

FLIGHT #3: EXT STBD SPL - MIC 3 SPL

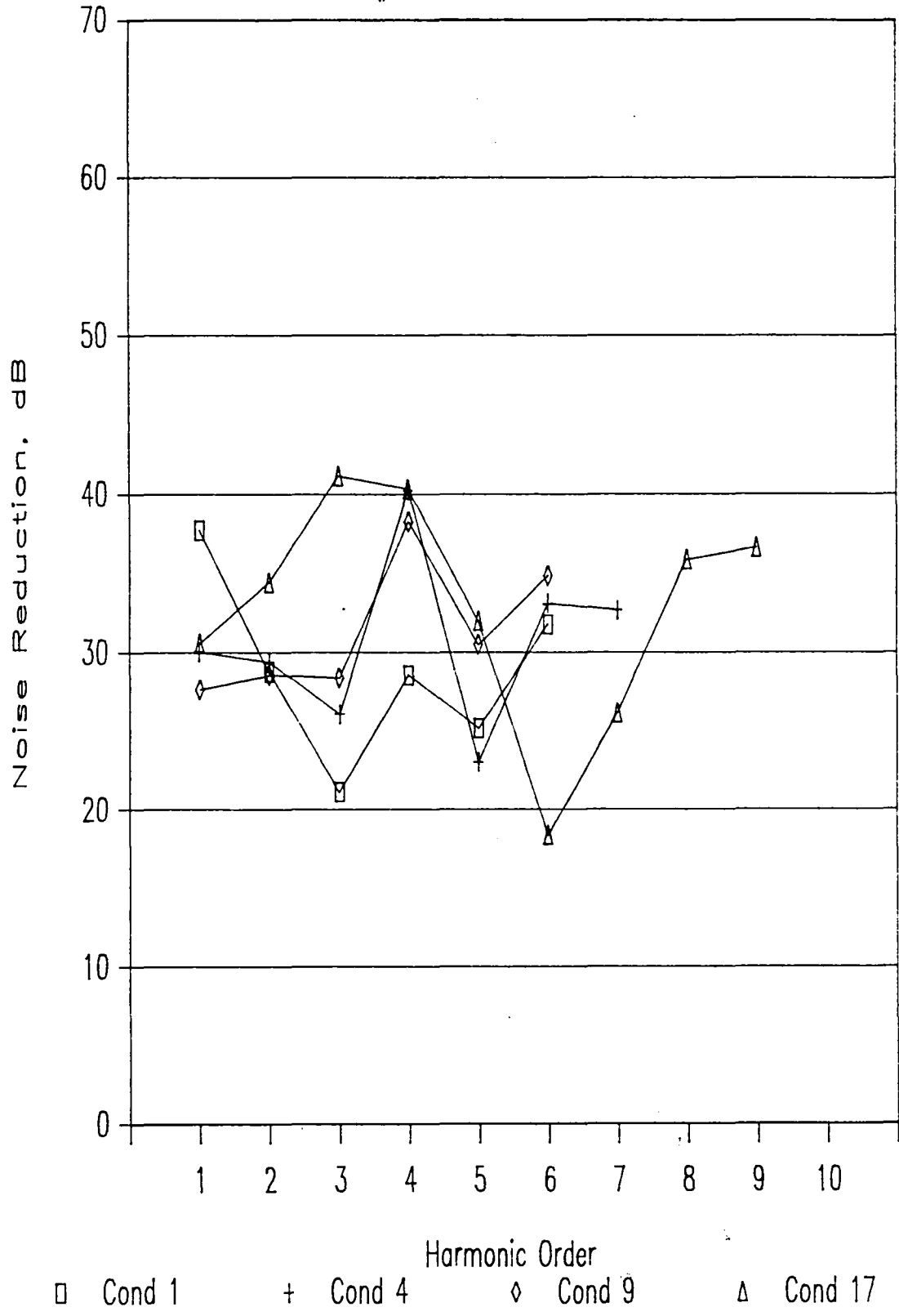

FIGURE 46. HARMONIC NOISE REDUCTION FOR UNTREATED CABIN: FLIGHT 3, EXTERIOR STARBOARD MICROPHONE, INTERIOR MICROPHONE LOCATION 3.

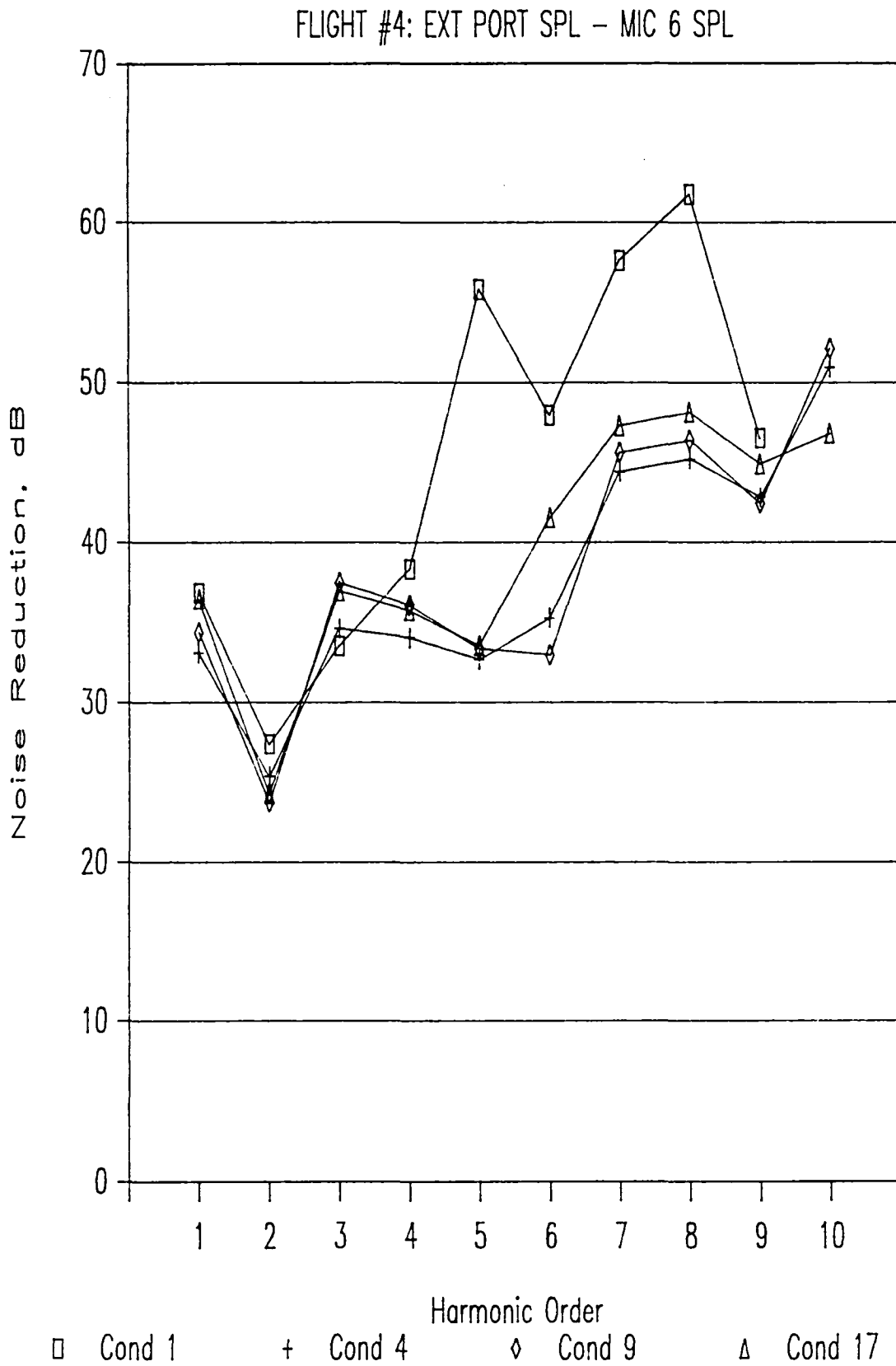

FIGURE 47. HARMONIC NOISE REDUCTION FOR TREATED CABIN: FLIGHT 4, EXTERIOR PORT MICROPHONE, INTERIOR MICROPHONE LOCATION 6.

FLIGHT #4: EXT STBD SPL - MIC 3 SPL

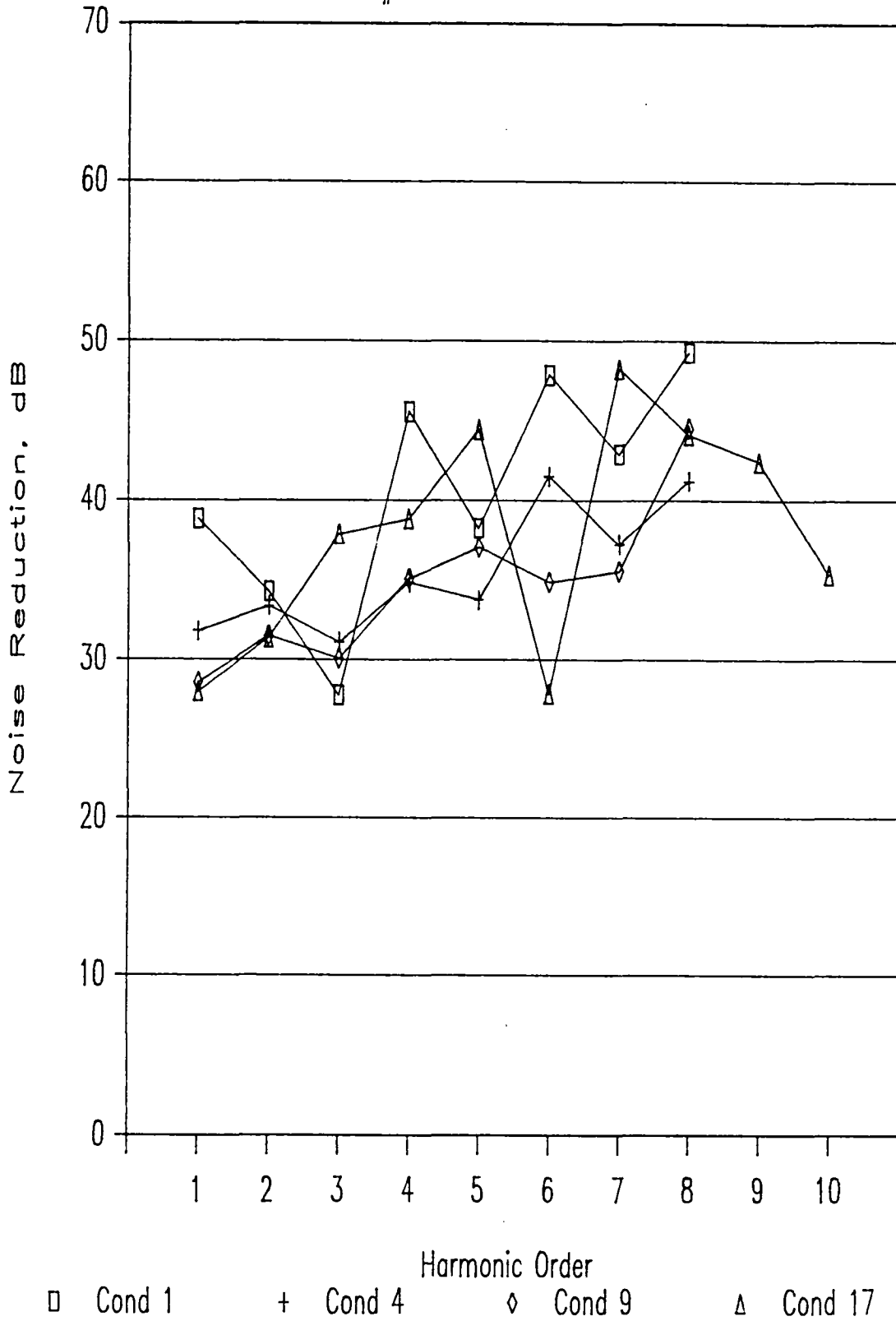

FIGURE 48. HARMONIC NOISE REDUCTION FOR TREATED CABIN: FLIGHT 4, EXTERIOR STARBOARD MICROPHONE, INTERIOR MICROPHONE LOCATION 3.

show more scatter and appear to be independent of harmonic order in the untreated cabin. Even when the cabin is treated with fiberglass there is only a weak increase of noise reduction as harmonic order increases.

Associated one-third octave band noise reduction spectra are given in Appendices H and I, and Figures 49 through 52. Interpretation of these spectra has to be performed with caution since the noise reduction is a function of the transmission loss provided by the sidewall, the absorption in the cabin, the dominant excitation at a particular frequency and the dominant transmission path. As an example consider the low frequency range below 100 Hz. The one-third octave band noise reduction spectra show low noise reduction in the 25 Hz band, high noise reduction in the 40 Hz (and sometimes the 50 Hz) band and relatively low noise reductions in the 50 to 80 Hz bands. Inspection of the corresponding narrowband spectra for the exterior and interior sound pressures shows that the interior sound field contains a strong discrete component at the blade passage frequency of about 77 Hz and fairly strong components at the propeller shaft rotational frequency of about 26 Hz (and sometimes at its second harmonic of about 52 Hz). In contrast the exterior pressure field contains only the 77 Hz component at the blade passage frequency. It is possible that the propeller shaft component is structureborne and, thus, in this type of analysis the "noise reduction" will be artificially low. At frequencies between the discrete components the exterior pressure field is probably dominated by the turbulent boundary layer on the fuselage. Typically, at low frequencies this excitation is not very efficient at exciting the structure; the corresponding noise reduction will thus be high--as is shown in the 40 Hz band. Finally, the propeller blade passage component lies in the 80 Hz band and the dominant transmission path may well be airborne

FLIGHT #3. EXT PORT - MIC #6

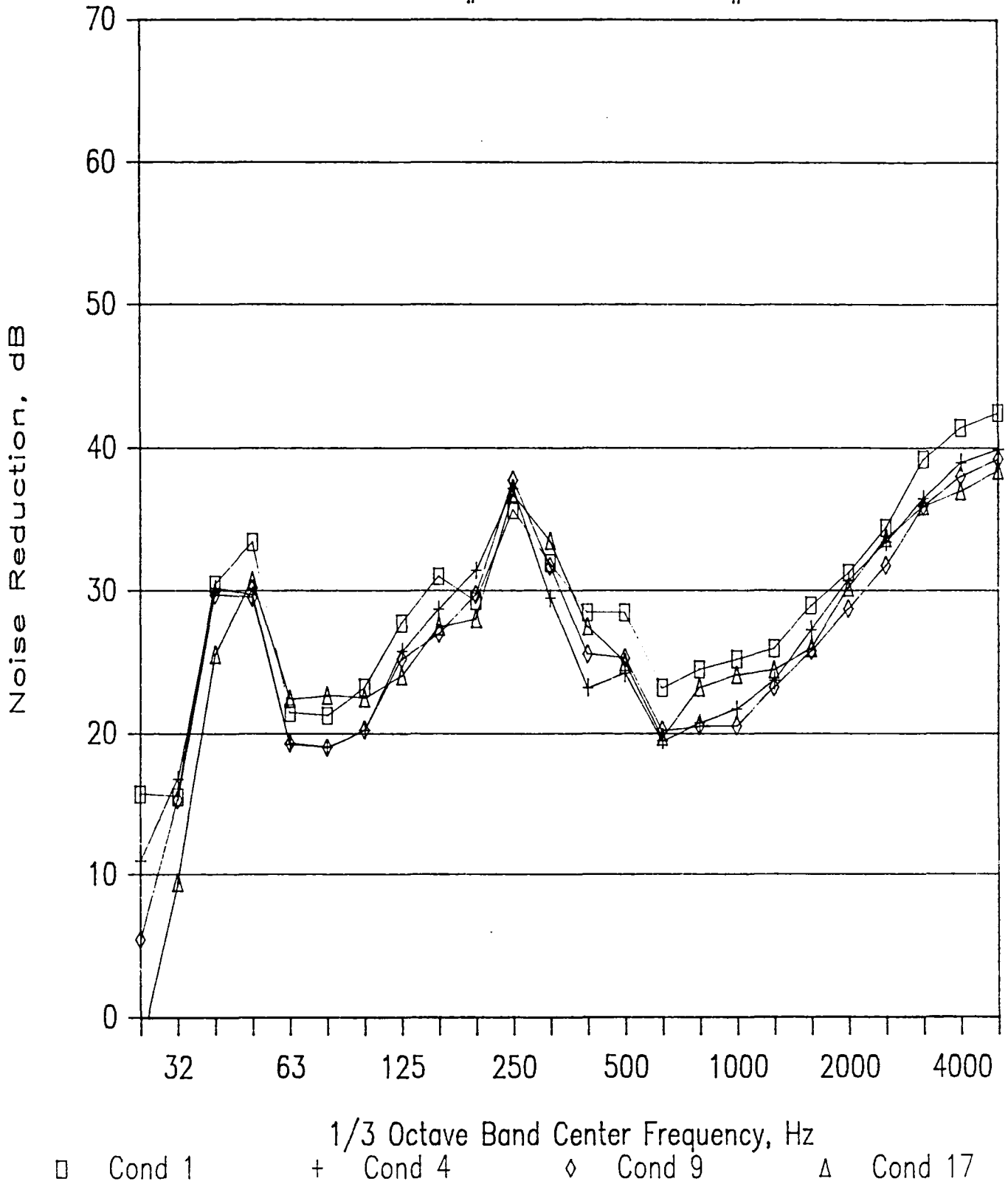

FIGURE 49. ONE-THIRD OCTAVE BAND NOISE REDUCTION FOR UNTREATED CABIN: FLIGHT 3, EXTERIOR PORT MICROPHONE, INTERIOR MICROPHONE LOCATION 6.

FLIGHT #3. EXT STARBOARD - MIC #3

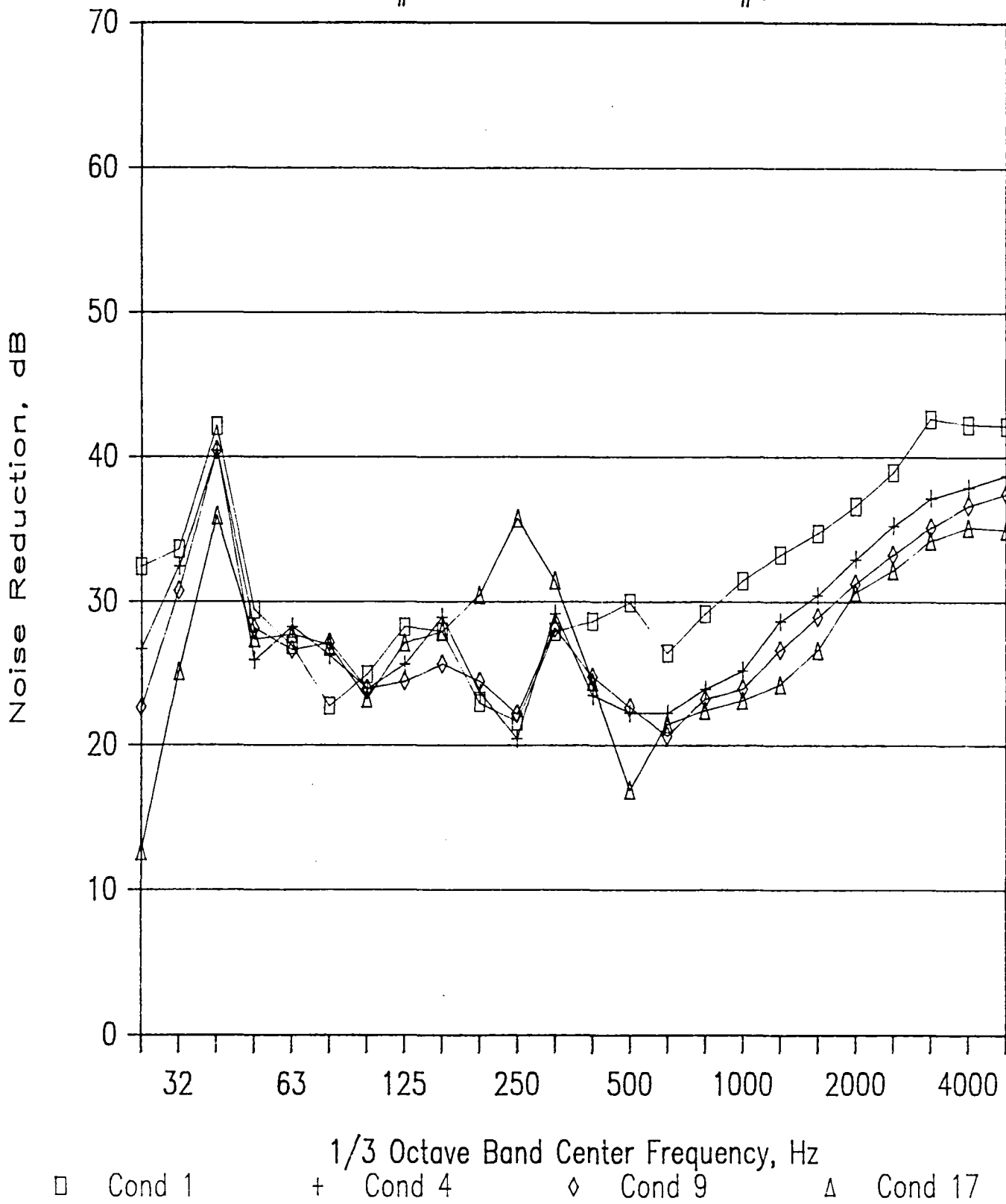

FIGURE 50. ONE-THIRD OCTAVE BAND NOISE REDUCTION FOR UNTREATED CABIN: FLIGHT 3, EXTERIOR STARBOARD MICROPHONE, INTERIOR MICROPHONE LOCATION 3.

FLIGHT #4. EXT PORT - MIC #6

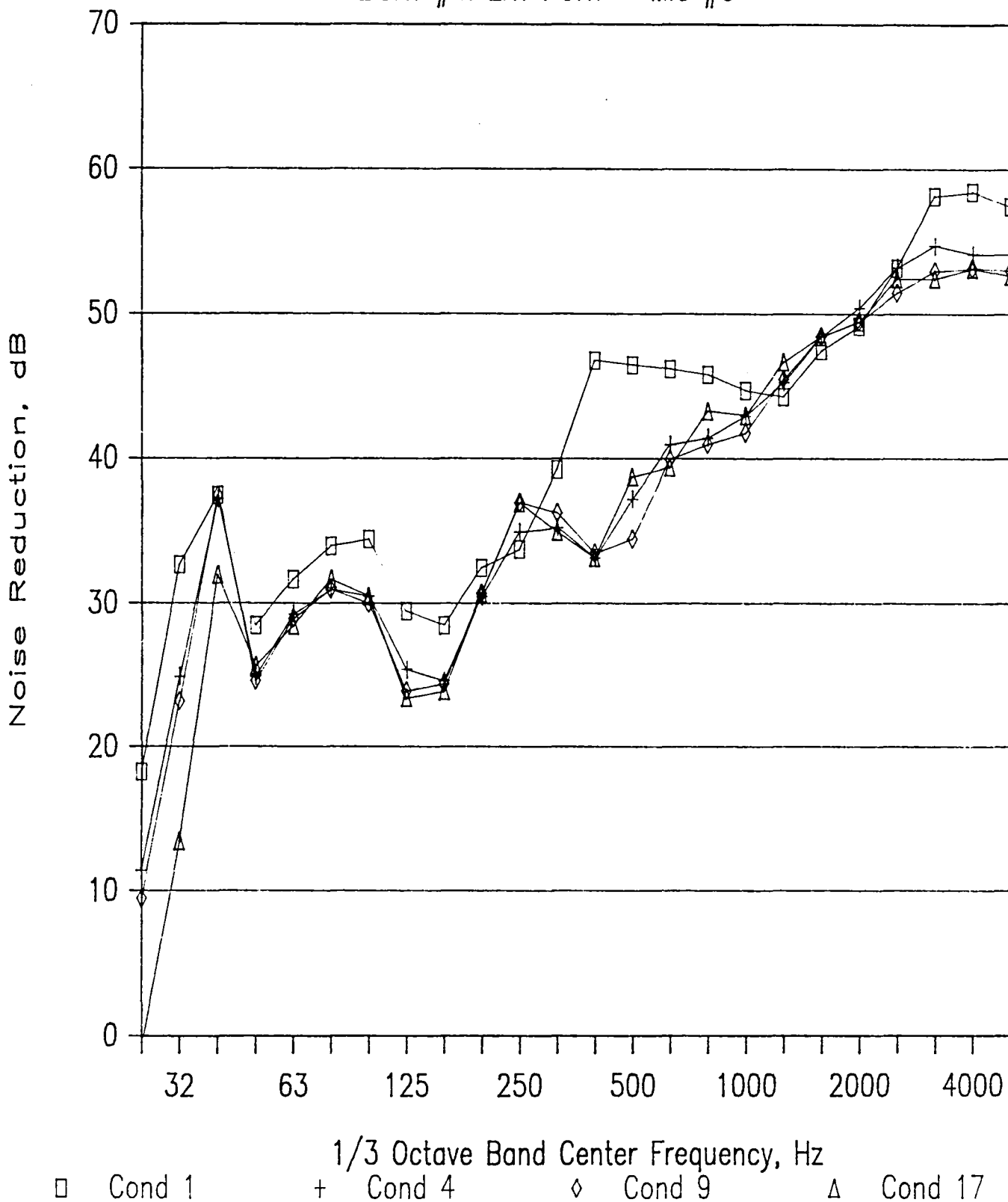

FIGURE 51. ONE-THIRD OCTAVE BAND NOISE REDUCTION FOR TREATED CABIN: FLIGHT 4, EXTERIOR PORT MICROPHONE, INTERIOR MICROPHONE LOCATION 6.

FLIGHT #4. EXT STARBOARD - MIC #3

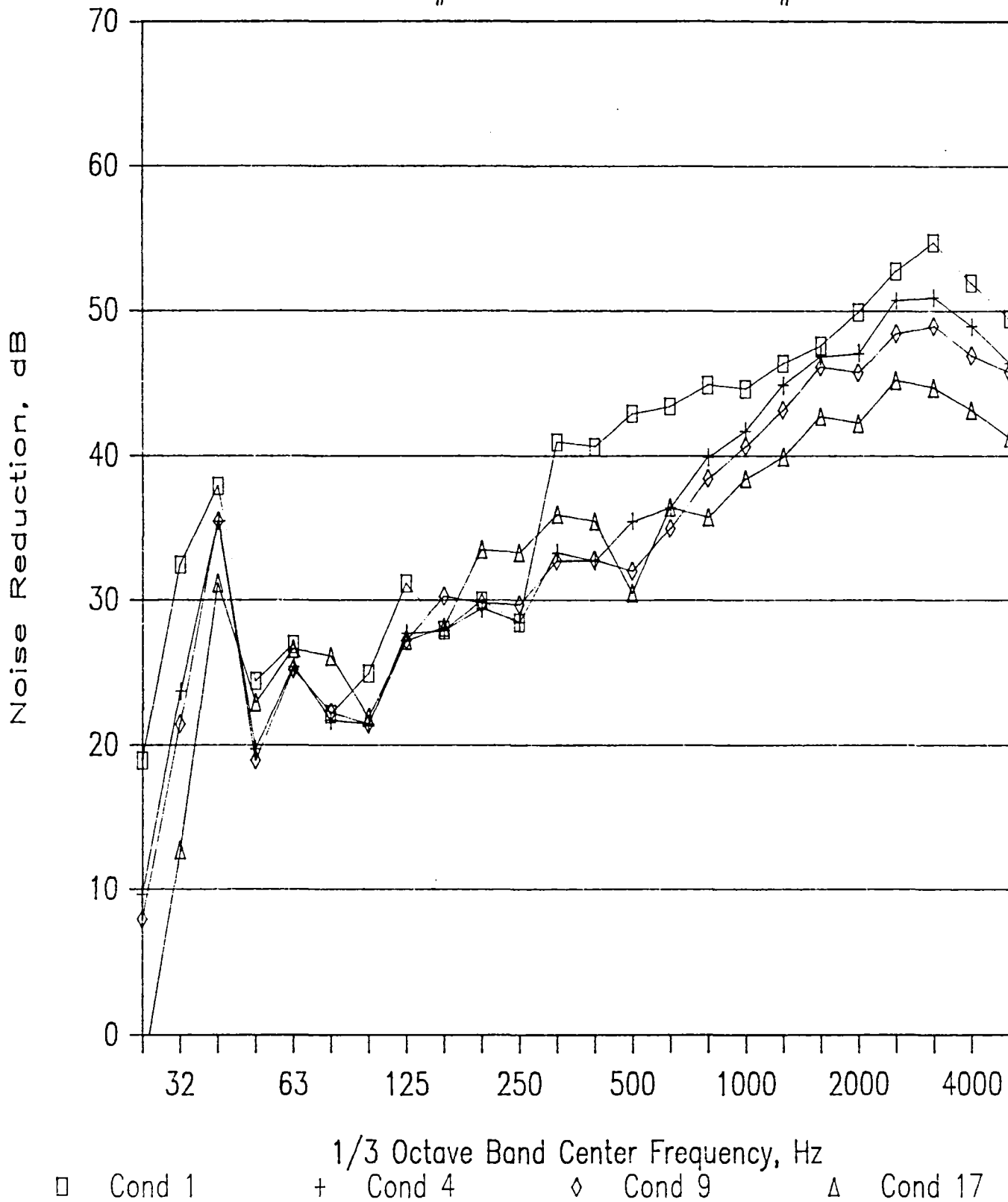

FIGURE 52. ONE-THIRD OCTAVE BAND NOISE REDUCTION FOR TREATED CABIN: FLIGHT 4, EXTERIOR STARBOARD MICROPHONE, INTERIOR MICROPHONE LOCATION 3.

through the sidewall. Thus, the usual noise reduction interpretation is valid in this frequency band, with the understanding that the actual value measured will be dependent on the particular choice of location for the exterior microphone.

At frequencies above about 630 Hz for the untreated cabin the main noise source is the exterior turbulent boundary layer, and the noise reduction increases in value as frequency increases, at a rate somewhat greater than 6 dB for a doubling of frequency. When the fiberglass treatment is introduced this high frequency regime begins at a much lower frequency--about 160 Hz. This is to be expected because the fiberglass increases both the transmission loss through the sidewall and the absorption in the cabin, particularly at higher frequencies.

The data in Figures 49 through 52, and in Appendices H and I show that for the untreated cabin the noise reduction lies in the range 20 to 30 dB for much of the frequency range of interest. When the fiberglass treatment is installed the noise reduction is greater than 30 dB for most frequencies shown.

6.3 Insertion Loss

The insertion loss provided by the fiberglass treatment is represented by the change in sound pressure levels measured in the treated and untreated cabin. Values of the insertion loss can be obtained, for example, by comparing sound pressure levels measured in the cabin before (flight 3) and after (flight 4) installation of the treatment. Simple spectral comparisons of this type are made in Figures 36 and 37, and discussed in Section 5. The discussion will now be taken a step further by considering first the changes in harmonic sound pressure level and then the changes in one-third octave band sound pressure level.

Insertion losses measured at harmonics of the blade passage frequency are listed in Appendix J for microphone locations 3 and 6, and plotted in Figures 53 through 56. The insertion losses were obtained simply by calculating the difference in cabin sound pressure level between flights 3 (untreated cabin) and flight 4 (treated cabin). Consequently, no account was taken of any possible change in exterior sound pressure level.

The data in Figures 53 through 56 show some general trends of increasing insertion loss with increasing frequency. There is, however, quite a large amount of scatter in the data. This is not surprising since the insertion loss represents the difference between two measured sound pressure levels which themselves have significant data variability, as has been discussed in earlier sections of this report. The data presented in the four figures represent examples from four nominal flight conditions--zero pressure differential (condition 1) and full pressure differential (condition 4) at an altitude of 3,000 m, and full pressure differential at altitudes of 4,600 m (condition 9) and 9,100 m (condition 17). However, it is difficult to determine any particular influence of flight condition on the measured insertion loss values shown in Figures 53 through 56.

It was thought possible that part of the scatter in the data could be attributed to variations in the exterior sound pressure levels from flight 3 to flight 4. Thus, the measured insertion loss was recalculated by taking the differences between the measured noise reductions for flights 3 and 4. In this manner, any changes in exterior sound pressure level were taken into account. Resulting insertion loss values are tabulated in Appendix K and plotted in Figures 57 and 58.

FLT #3-#4: MIC 3, PORT ENGINE COMP.

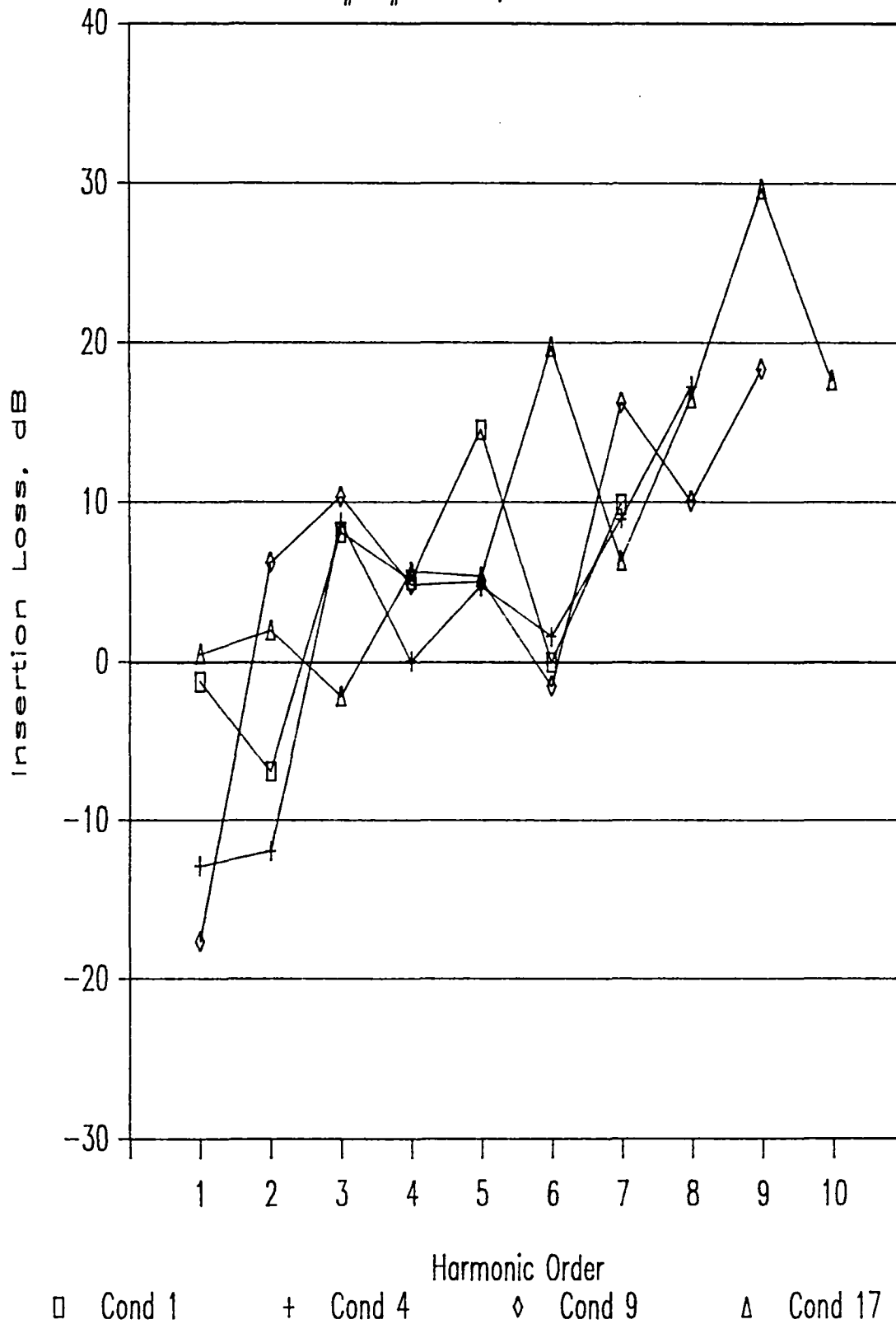

FIGURE 53. HARMONIC INSERTION LOSS PROVIDED BY FIBERGLASS TREATMENT: PORT PROPELLER COMPONENT, INTERIOR MICROPHONE 3. (NO ADJUSTMENT FOR CHANGE IN EXTERIOR SOUND PRESSURE LEVEL)

FLT #3-#4: MIC 3, STBD ENGINE COMP.

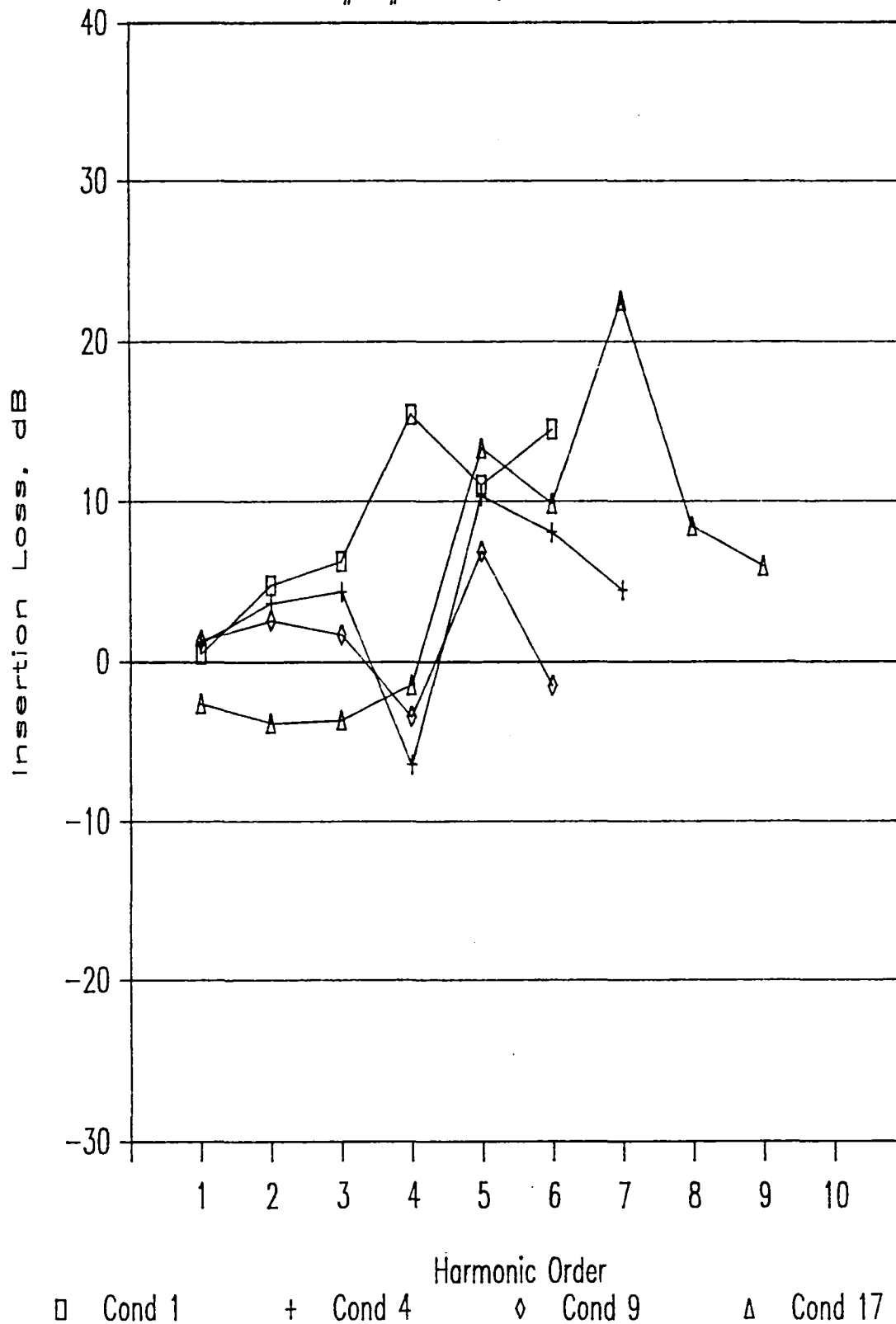

FIGURE 54. HARMONIC INSERTION LOSS PROVIDED BY FIBERGLASS TREATMENT: STARBOARD PROPELLER COMPONENT, INTERIOR MICROPHONE 3. (NO ADJUSTMENT FOR CHANGE IN EXTERIOR SOUND PRESSURE LEVEL)

FLT #3-#4: MIC 6, PORT ENGINE COMP.

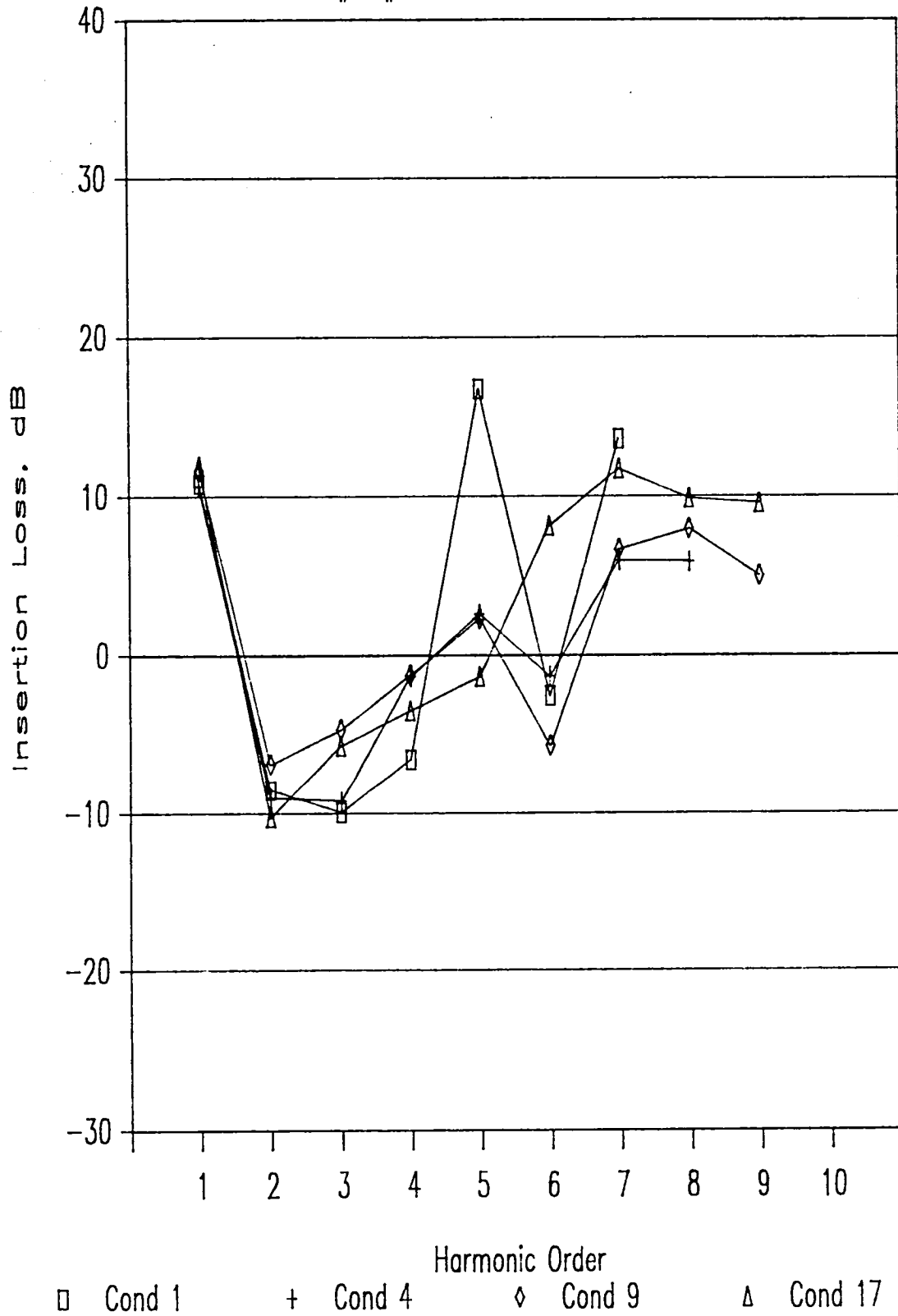

FIGURE 55. HARMONIC INSERTION LOSS PROVIDED BY FIBERGLASS TREATMENT: PORT PROPELLER COMPONENT, INTERIOR MICROPHONE 6. (NO ADJUSTMENT FOR CHANGE IN EXTERIOR SOUND PRESSURE LEVEL)

FLT #3-#4: MIC 6, STBD ENGINE COMP.

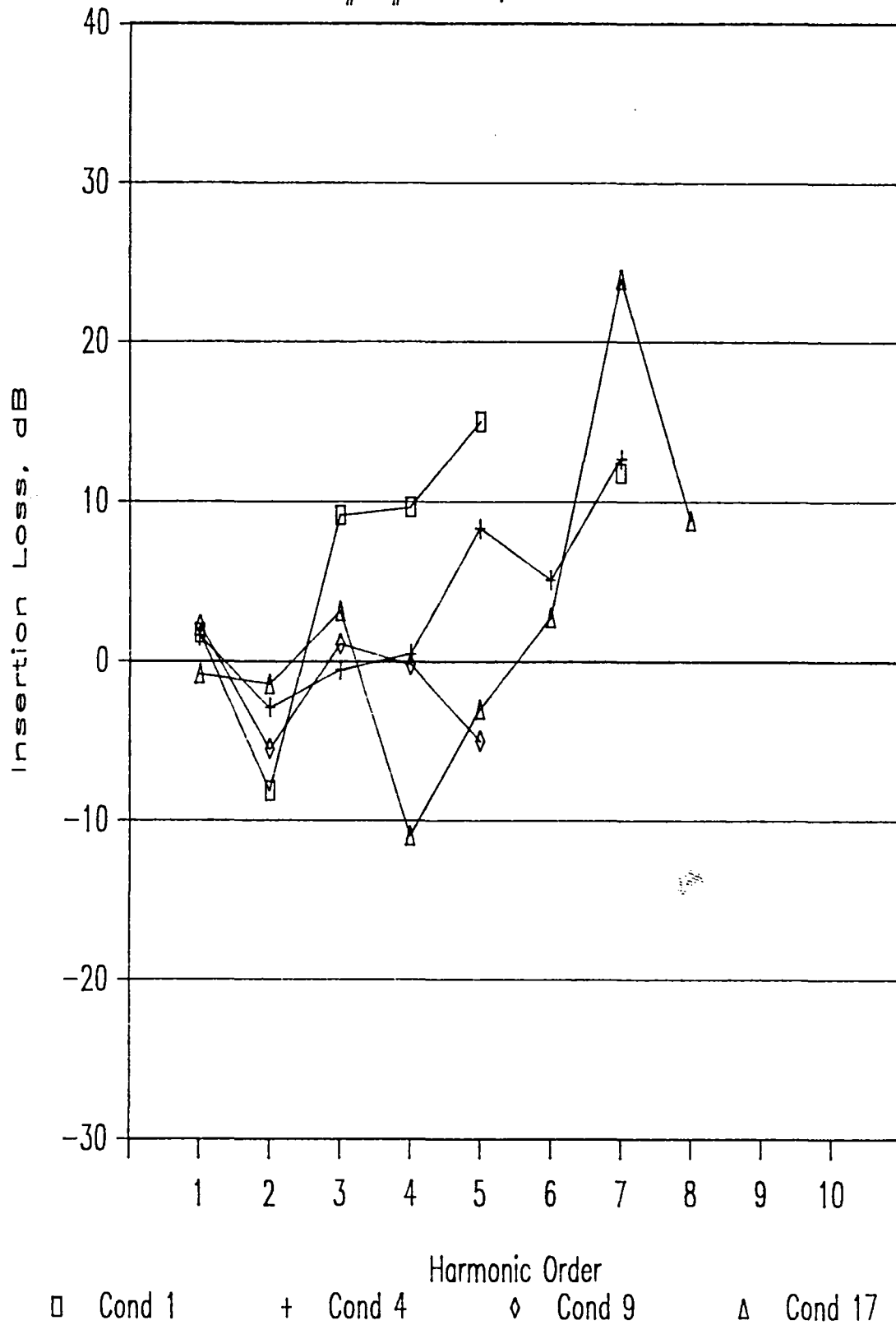

FIGURE 56. HARMONIC INSERTION LOSS PROVIDED BY FIBERGLASS TREATMENT: STARBOARD PROPELLER COMPONENT, INTERIOR MICROPHONE 6. (NO ADJUSTMENT FOR CHANGE IN EXTERIOR SOUND PRESSURE LEVEL)

FLT #3-#4: MIC 3, STBD ENGINE COMP.

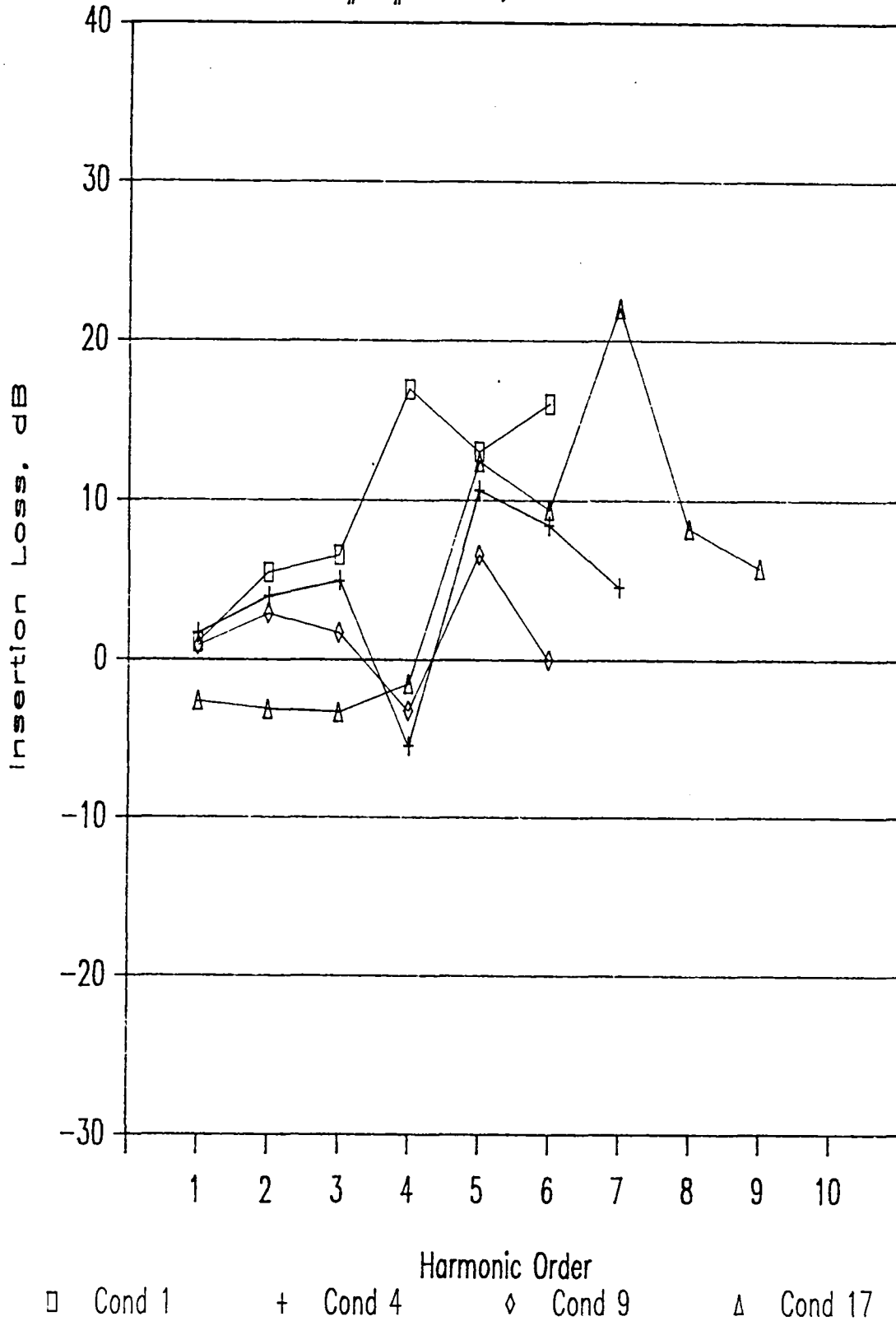

FIGURE 57. HARMONIC INSERTION LOSS PROVIDED BY FIBERGLASS TREATMENT: STARBOARD PROPELLER COMPONENT, INTERIOR MICROPHONE 3. (ADJUSTED FOR CHANGE IN EXTERIOR SOUND PRESSURE LEVEL)

FLT #3-#4: MIC 6, PORT ENGINE COMP.

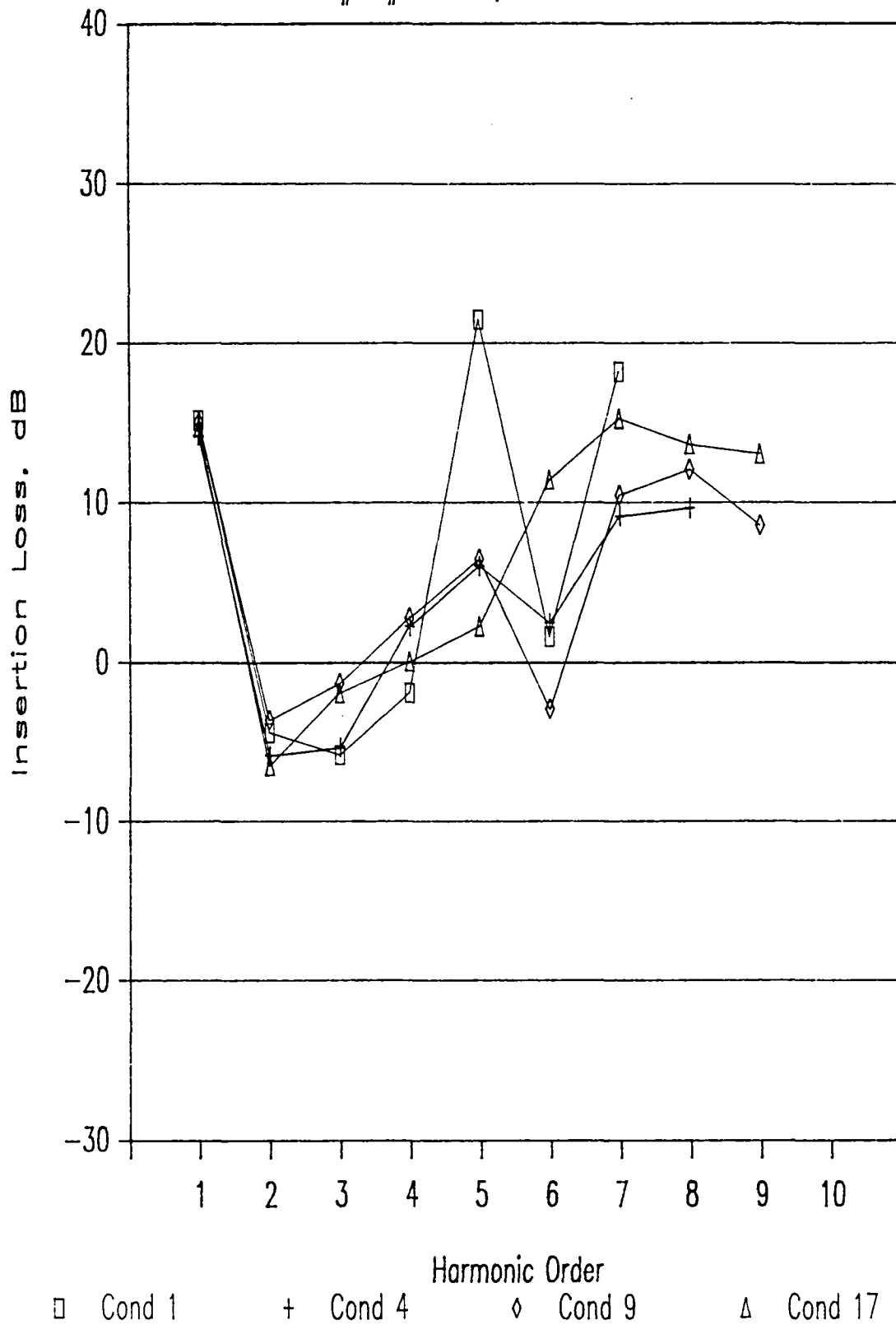

FIGURE 58. HARMONIC INSERTION LOSS PROVIDED BY FIBERGLASS TREATMENT: PORT PROPELLER COMPONENT, INTERIOR MICROPHONE 6. (ADJUSTED FOR CHANGE IN EXTERIOR SOUND PRESSURE LEVEL)

Comparison of Figures 54 and 57 or Figures 55 and 58 shows that the inclusion of changes in exterior sound pressure levels has only a negligible effect on the variability of the measured insertion loss. Thus the variability must be caused by other, as yet unidentified, factors. A more extensive analysis of all the test data might provide a better understanding of the insertion loss and the reasons for the data variability.

Examples of insertion loss spectra measured in one-third octave frequency bands are given in Figures 59 and 60. A more complete tabular presentation is given in Appendix J. The spectra for the two microphone locations show some similarities at high frequencies and some differences at low frequencies.

At low frequencies, the spectra for location 3 exhibit a fairly smooth increase in insertion loss as frequency increases. In contrast the corresponding data for microphone location 6 show relatively high insertion losses at some frequencies and low insertion losses at other frequencies. The results are quite repeatable for the wide range of test conditions considered. The high insertion losses measured at location 6 occur at frequencies close to the propeller shaft rotational frequency and the propeller blade passage frequency.

At frequencies above about 250 Hz, the measured insertion losses are similar for the two locations and have maximum values of 15 to 20 dB in the frequency range 630-1600 Hz. At higher frequencies, the measured insertion loss appears to decrease as frequency increases. However, it is believed that this phenomenon was caused by the limited dynamic range of the tape recorder. This limitation affected the recording of high frequency sound pressure levels in the treated cabin.

FLIGHT #3 - FLIGHT #4. MIC #3

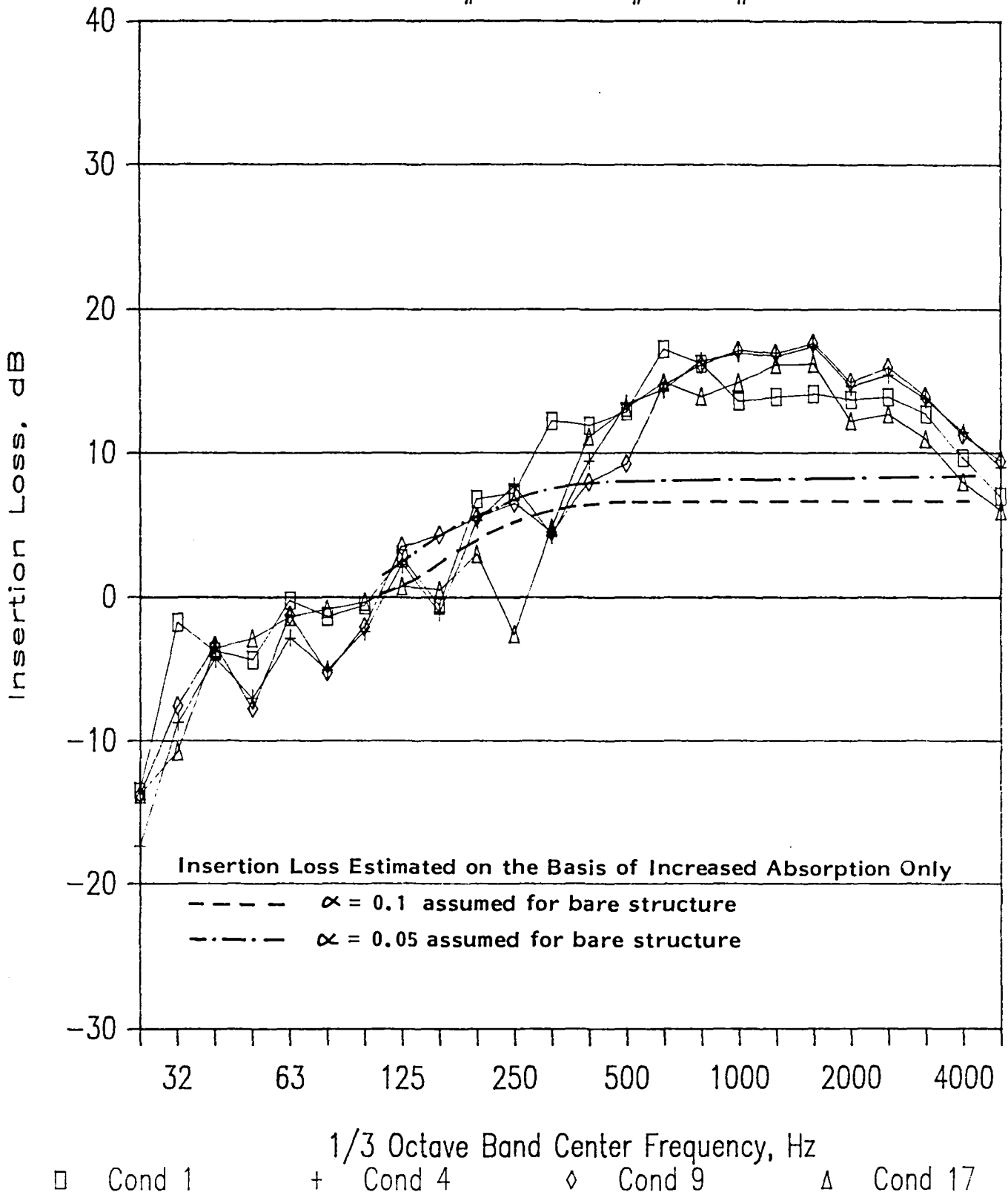

FIGURE 59. ONE-THIRD OCTAVE BAND INSERTION LOSS PROVIDED BY FIBERGLASS TREATMENT: INTERIOR MICROPHONE LOCATION 3. (NO ADJUSTMENT FOR CHANGE IN EXTERIOR SOUND PRESSURE LEVEL)

FLIGHT #3 - FLIGHT #4. MIC #6

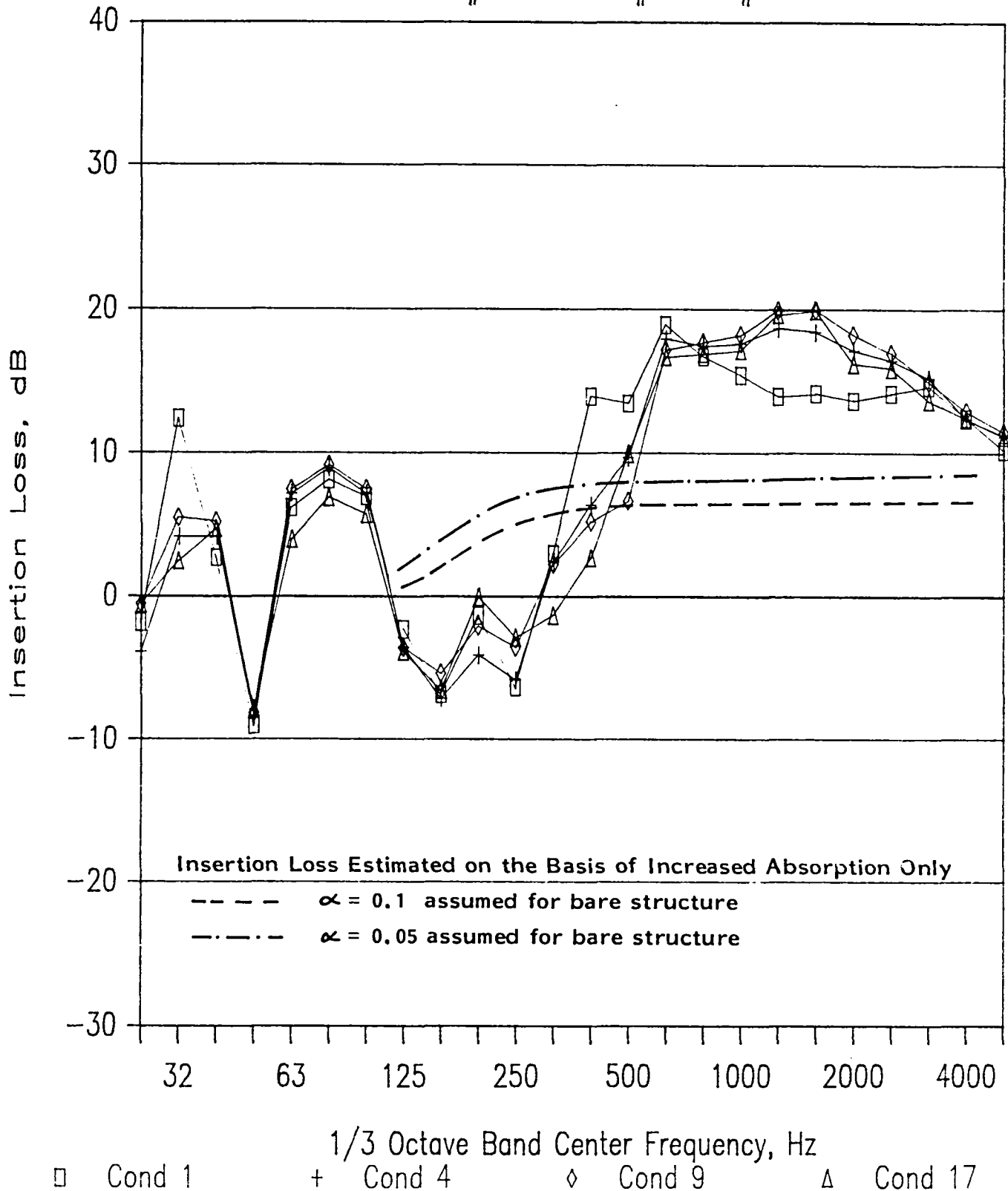

FIGURE 60. ONE-THIRD OCTAVE BAND INSERTION LOSS PROVIDED BY FIBERGLASS TREATMENT: INTERIOR MICROPHONE LOCATION 6. (NO ADJUSTMENT FOR CHANGE IN EXTERIOR SOUND PRESSURE LEVEL)

The one-third octave band spectra in Figures 59 and 60 show negative insertion losses in some low frequency bands. This means that the measured sound pressure levels were higher in the treated cabin than in the untreated cabin. Similar results were observed for the harmonic sound pressure levels. Data from earlier tests [9] show similar trends, but the occurrence of negative insertion losses in one-third octave band spectra was essentially eliminated when discrete frequency harmonic components were artificially removed from the computation.

The insertion loss provided by the fiberglass treatment is influenced by transmission loss and absorption characteristics. An estimate of the effect of acoustic absorption can be obtained using available manufacturers data and approximations. The data used in the analysis are shown in Table 11. In addition, values of 0.05 and 0.1 were assumed for the absorption coefficient of the bare structure (skin and windows). Estimated insertion losses, associated with only the changes in acoustic absorption in the cabin, are shown in Figures 59 and 60. The predictions are generally consistent with the measured data.

TABLE 11

ASSUMED ACOUSTIC ABSORPTION PROPERTIES

Frequency (Hz)	125	250	500	1000	2000	4000
Absorption Coefficients						
Sidewall Treatment	0.19	0.70	0.99	1.0	1.0	1.0
Cockpit Curtain	0.20	0.50	0.70	0.90	1.0	1.0
Absorption for Seat with Occupant						
Sabins (m ²)	0.31	0.33	0.41	0.45	0.42	0.41
(ft ²)	3.3	3.6	4.4	4.8	4.5	4.4

7.0 CONCLUSIONS

The flight test measurements provided information on exterior and interior sound pressure levels which will be of value to future in-flight evaluations of cabin acoustic treatments for propeller-driven aircraft. The results are summarized in these conclusions.

7.1 Data Variability

One of the important results of this flight test program is that, for the first time, it is possible to establish the repeatability of measured propeller sound pressure levels at harmonics of the blade passage frequency. The extent to which the data are repeatable is a critical factor in the in-flight evaluation of noise control treatments installed in an airplane cabin. It was found in the present test program that there was some variability in the measurements; a general estimate of this variability was obtained by taking the range of sound pressure levels (i.e., the difference, in decibels, between maximum and minimum measured values) for each harmonic under each test condition. The data ranges were then averaged over all harmonics and over all three flight altitudes for each of the two propeller nominal rotational speeds.

In the case of the exterior sound pressure levels, the average range of sound pressure levels for an identical harmonic was 3 to 5 dB, depending on propeller rpm, with the greatest observed variation being about 8 dB at higher order harmonics. The standard deviation for the range of harmonic sound pressure levels relative to the mean was about 1.5 dB. Somewhat greater variability was observed in the interior sound pressure levels. If the propellers were operated at different rotational speeds, or at the same

rotational speed and the same nominal relative phase angle, the average range of sound pressure levels for an individual harmonic was 4 to 6 dB. The associated standard deviation for the range of harmonic sound pressure levels about the mean was 3 to 4 dB. When relative phase angle was not controlled the average range of harmonic sound pressure levels in the cabin was about 10 dB. It should be noted, however, that the new generation of synchrophasers provide much closer control of relative phase between the two propellers than was achieved on the test airplane; the associated variability in harmonic sound pressure levels should then be reduced.

Implicit in this evaluation of data repeatability is the choice of effective filter bandwidth used in the data reduction process. The bandwidth should be narrow enough to exclude unwanted signals, but wide enough to accept all the acoustic energy associated with the harmonic. The data from the present tests indicated that the propeller rpm was very stable during the data record sample, so that filter bandwidths of 0.5 to 1.0 Hz could be used.

7.2 Exterior Sound Pressure Levels

Measurements of the sound field on the exterior of the fuselage showed that the harmonic sound pressure levels for the propeller adjacent to the microphone were 15 to 20 dB higher than the corresponding values generated by the propeller on the opposite side of the fuselage. Sound pressure levels generated by the port propeller and measured on the port side of the fuselage were typically 2 to 3 dB higher than those on the starboard side generated by the starboard propeller. Viewed from the rear, the propellers rotate in a counter-clockwise direction and the microphones were about 5 cm (2 inches) below the center of the propeller shaft. Thus, it might be said that the port propeller was approaching the port microphone and the starboard propeller leaving the starboard

microphone. However, the difference between port and starboard sides appear to be extremely small.

The measured propeller overall sound pressure levels were 7 to 10 dB lower than values predicted using two simple empirical models. Harmonic levels, expressed relative to the associated overall sound pressure levels, lie between the values predicted by the two simple models.

Broadband sound pressure levels measured on the exterior of the fuselage can be predicted, approximately, using an empirical model for the pressure fluctuations beneath an attached turbulent boundary layer in a zero pressure gradient.

7.3 Interior Sound Pressure Levels

Cabin sound pressure levels were found to increase at some frequencies and decrease at others when cabin pressure differential was increased. However, only in very few frequency bands did the increase exceed the value predicted on the basis of the air density change in the cabin. Thus, it is concluded that increased pressure differential generally would reduce the acoustic radiation from the structure, if the air density in the cabin remained constant.

Noise reductions provided by the untreated cabin were in the range of 20 to 40 dB when the exterior and interior sound pressure levels were measured at locations which were close to the plane of rotation of the propeller. Introduction of an acoustic treatment consisting of 5 cm (2 inches) of fiberglass on the walls and ceiling of the cabin plus a foam and leaded-vinyl barrier between the cabin and the cockpit increased the noise reduction in the cabin at frequencies above about 200 Hz, but there was an apparent decrease in the noise reduction in some lower frequency bands;

similar effects have been observed in previous test results. Part of the increase in high frequency noise reduction can be attributed to an increase in the acoustic absorption in the cabin. There was no observable change in the sound pressure levels in the cockpit.

7.4 General Comments

Flanking paths play an important role in the experimental evaluation of noise control treatments. On the basis of the present study, it is concluded that an acoustic barrier should be provided between the cockpit and the cabin to eliminate that flanking path. Other tests are necessary to determine the roles played by windows, floor, structureborne noise and other factors. It is probable that these factors will be critical when evaluating noise control treatments which provide high noise reductions.

REFERENCES

1. Vaicaitis, R., Mixson, J.S., "Theoretical Design of Acoustic Treatment for Cabin Noise Control of a Light Aircraft", AIAA Paper 84-2328, October 1984.
2. Vaicaitis, R., Slazak, M., "Design of Sidewall Treatment for Cabin Noise Control of a Twin Engine Turboprop Aircraft", NASA Contractor Report 172245, December 1983.
3. Vaicaitis, R., "Study of Noise Transmission Through Double Wall Aircraft Windows", NASA Contractor Report 172182, October 1983.
4. Vaicaitis, R., Slazak, N., "Cabin Noise Control for Twin Engine General Aviation Aircraft", NASA Contractor Report 165833, February 1982.
5. Vaicaitis, R., Chang, M.T., Slazak, M., "Noise Transmission and Attenuation for Business Aircraft", SAE Paper 810561, April 1981.
6. Vaicaitis, R., "Noise Transmission into a Light Aircraft", J. Aircraft, 17, 2, 81-86, February 1981.
7. Vaicaitis, R., Slazak, M., "Noise Transmission through Stiffened Panels", J. Sound and Vibration, 70, 3, 413-426, 1980.
8. Grosveld, F.W., Mixson, J.S., "Noise Transmission through an Acoustically-Stiffened Aircraft Sidewall", AIAA Paper 84-2329, October 1984.
9. Mixson, J.S., O'Neal, R.L., Grosveld, F.W., "Investigation of Fuselage Acoustic Treatment for a Twin-Engine Turboprop Aircraft in Flight and Laboratory Tests", NASA Technical Memorandum 85722, January 1984.
10. Grosveld, F.W., "Noise Transmission through Sidewall Treatments Applicable to Twin-Engine Turboprop Aircraft", AIAA Paper 83-0695, April 1983.
11. Vaicaitis, R., Bofilios, D.A., Eisler, R., "Experimental Study of Noise Transmission into a General Aviation Aircraft", NASA Contractor Report 172357, June 1984.
12. Barton, C.K., Mixson, J.S., "Noise Transmission and Control for a Light Twin-Engine Aircraft", J. Aircraft, 18, 7, 570-575, July 1981.

REFERENCES

13. Mixson, J.S., Barton, C.K., Vaicaitis, R., "Investigation of Interior Noise in a Twin-Engine Light Aircraft", J.Aircraft, 15, 4, 227-233, April 1978.
14. Roussos, L.A., Mixson, J.S., "Acceleration Response of Fuselage Sidewall Panels on a Twin-Engine, Light Aircraft", Proceedings, Noise-Con 81, 291-294, 1981.
15. Piersol, A.G., Wilby, E.G., Wilby, J.F., "Evaluation of Aero Commander Propeller Acoustics Data: Static Operations", NASA Contractor Report 158919, May 1978.
16. Piersol, A.G., Wilby, E.G., Wilby, J.F., "Evaluation of Aero Commander Propeller Acoustic Data: Taxi Operations", NASA Contractor Report 159124, July 1979.
17. Piersol, A.G., Wilby, E.G., Wilby, J.F., "Evaluation of Aero Commander Sidewall Vibration and Interior Acoustic Data: Static Operations", NASA Contractor Report 159290, October 1980.
18. Barton, C.K., Mixson, J.S., "Characteristics of Propeller Noise on an Aircraft Fuselage", J.Aircraft, 18, 3, 200-205, March 1981.
19. Wilby, J.F., O'Neal, R.L., Mixson, J.S., "Flight Investigation of Cabin Noise Control Treatment for a Light Turboprop Aircraft", SAE Paper 850876, 1985 SAE General Aviation Aircraft Meeting and Exposition, Wichita, KA, April 1985.
20. Olcott, J.W., Larson, G.C., Aarons, R.N., "B/CA Analysis: Gulfstream 1000", (see photograph, p. 50) Business and Commercial Aviation, 49, 2, pp. 49-52, August 1981.
21. Anon., "Prediction Procedure for Near-Field and Far-Field Propeller Noise", SAE Aerospace Information Report AIR-1407, May 1977.
22. Ungar, E.E., et al., "A Guide for Estimation of Aeroacoustic Loads on Flight Vehicle Surfaces", AFFDL-TR-76-91, Vol. I, February 1977.
23. Bhat, W.V., "Flight Test Measurement of Exterior Turbulent Boundary Layer Pressure Fluctuations on Boeing Model 737 Airplane", J.Sound and Vibration, 14, 4, 433-457, 1971.

APPENDIX A

Exterior Fluctuating Pressure Levels at Harmonics of Propeller
Blade Passage Frequency: Flights 1 through 4.

- Notes (1) Sound pressure levels measured on the port side refer to the port propeller, and on the starboard side to the starboard propeller.
- (2) Adjustments for broadband contributions were made on an energy basis, with the broadband pressure level estimated from the measured levels on either side of the harmonic peak.

TABLE A.1

EXTERIOR FLUSH-MOUNTED MICROPHONE : PORT SIDE

Test Condition	Flight Number	RPM	BPF Hz	Harmonic Level, dB re 20 micro Pa										
				1	2	3	4	5	6	7	8	9	10	
1	1	1580.0	79.0											
	2	1572.5	78.6	132.8	132.2	129.5	124.9	121.2	118.0	113.8	111.2	107.9	103.3 *	
	3	1572.5	78.6	130.0	129.4	127.0	122.5	118.1	115.1	111.0	107.0	102.7 *	98.6 *	
	4	1575.0	78.8	134.3	133.5	131.1	127.1	122.8	119.2	115.5	113.0	108.6	105.5	
	Average			132.7	132.0	129.5	125.2	121.1	117.7	113.8	111.0	107.1	103.3	
2	1	1525.0	76.3											
	2	1525.0	76.3	132.2	131.1	127.8	123.8	119.0	115.3	111.6	108.4	104.0 *	97.5 *	
	3	1525.0	76.3	130.0	128.5	125.2	121.0	115.9	112.1	108.2	104.2 *	99.4 *	96.1 *	
	4	1525.0	76.3	134.6	133.2	130.1	125.5	120.0	117.7	114.1	109.8	105.5 *	100.0 *	
	Average			132.7	131.3	128.1	123.8	118.6	115.6	111.9	108.0	103.6	98.2	
3	1	1527.5	76.4											
	2	1525.0	76.3	131.7	130.0	127.0	122.2	117.0	114.0	110.5	107.3	102.4 *	96.6 *	
	3	1525.0	76.3	129.0	127.0	123.6	119.2	113.9	110.0	106.3	103.5	98.1 *	93.0 *	
	4	1527.5	76.4	132.9	131.9	128.4	123.5	118.1	115.3	112.0	108.1	103.4 *	98.7 *	
	Average			131.5	130.1	126.8	122.0	116.7	113.6	110.2	106.7	101.8	96.7	
4	1	1572.5	78.6											
	2	1572.5	78.6	131.0	130.3	127.4	122.7	119.0	115.9	111.3	108.1	103.6 *	101.1 *	
	3	1572.5	78.6	129.3	129.0	125.6	120.7	117.1	113.8	110.0	107.0	101.2 *	99.3 *	
	4	1572.5	78.6	132.9	132.2	129.5	124.3	120.6	117.6	113.2	110.8	107.0	103.4 *	
	Average			131.3	130.7	127.8	122.8	119.1	116.0	111.7	108.9	104.6	101.6	
5	1	1532.5	76.6											
	2	1530.0	76.5	131.0	129.5	125.3	122.7	118.7	116.0	112.5	109.9	105.0	100.0 *	
	3	1530.0	76.5	128.9	127.8	123.1	119.4	115.2	111.6	108.7	105.2	101.7	95.7 *	
	4													
	Average			130.1	128.7	124.3	121.4	117.3	114.3	111.0	108.2	103.7	98.4	
6	1	1530.0	76.5											
	2	1532.5	76.6	130.3	131.2	127.5	122.6	119.8	114.3	112.3	108.9	104.8	99.9 *	
	3	1532.5	76.6	128.2	129.1	124.7	120.1	116.7	111.7	110.0	105.4	100.8 *	96.5 *	
	4													
	Average			129.4	130.3	126.3	121.5	118.5	113.2	111.3	107.5	103.2	98.5	
7	1	1530.0	129.0	129.0	128.1	124.3	121.3	115.2	112.7	109.6	107.4	101.6 *	98.0 *	
	2	1530.0	76.5	131.1	129.9	127.5	123.3	119.3	115.5	114.0	110.2	105.9	101.2 *	
	3	1530.0	76.5	128.8	127.3	123.8	120.5	115.9	112.1	109.2	106.8	101.5 *	97.6 *	
	4													
	Average			129.8	128.6	125.5	121.9	117.2	113.7	111.5	108.4	103.5	99.3	

* adjusted for Broadband Contributions

NA Not Available

TABLE A.1 (CONTINUED)

EXTERIOR FLUSH-MOUNTED MICROPHONE : PORT SIDE

Test Condition	Flight Number	RPM	BPF Hz	Harmonic Level, dB re 20 micro Pa									
				1	2	3	4	5	6	7	8	9	10
8	1	1530.0	76.5	129.0	128.8	124.0	120.8	116.5	113.3	109.7	107.0	101.5 *	97.5 *
	2	1532.5	76.6	131.2	131.0	126.9	122.6	118.8	115.0	112.1	109.0	104.5	99.1 *
	3	1530.0	76.5	128.9	128.5	123.9	120.2	115.0	112.2	108.3	105.9	100.5 *	96.8 *
	4												
	Average				129.8	129.6	125.2	121.3	117.1	113.7	110.3	107.5	102.5
9	1	1572.6	78.6	128.9	128.6	125.9	122.0	116.7	114.0	110.0	106.0	102.3 *	102.0 *
	2	1575.0	78.8	131.5	130.9	128.5	124.8	120.5	117.3	115.1	112.1	108.3	106.2
	3	1572.5	78.6	128.7	128.0	125.7	121.2	117.1	114.4	111.0	108.0	104.9	101.8
	4	1575.0	78.8	132.1	131.2	129.0	125.2	121.3	117.1	114.8	112.1	108.5	106.1
	Average				130.6	129.9	127.5	123.6	119.4	116.0	113.3	110.3	106.7
10	1	1525.0	76.3	130.2	128.1	125.3	121.1	115.8	113.1	110.2	106.3	101.3 *	97.2 *
	2	1525.0	76.3	132.0	130.5	127.6	123.3	119.1	115.2	113.1	110.1	105.2	101.4 *
	3	1525.0	76.3	128.6	127.0	123.7	119.6	115.1	110.8	108.8	105.5	101.2	95.6 *
	4	1527.5	76.4	132.2	131.4	128.4	123.8	119.6	117.2	113.6	109.7	106.2	101.2 *
	Average				131.0	129.6	126.6	122.3	117.8	114.7	111.9	108.4	104.0
11	1	1515.0	75.8										
	2	1515.0	75.8	110.6	109.1	101.3	92.9 *						
	3	1515.0	75.8	108.3	107.1	99.3	88.0 *						
	4	1515.0	75.8	111.0	110.6	104.1	94.1 *						
	Average				110.1	109.2	102.0	92.3	NA	NA	NA	NA	NA
12	1	1520.0	76.0	128.0	126.2	122.0	117.8	113.0	107.0	102.0	97.8 *	93.0 *	92.1 *
	2	1520.0	76.0	129.3	127.1	122.3	118.0	112.9	107.4	103.1	95.6 *	89.5 *	90.9 *
	3	1520.0	76.0	127.1	124.8	120.1	115.7	110.3	104.9	100.1	93.9 *	88.0 *	87.5 *
	4	1520.0	76.0	130.1	128.0	123.2	119.1	113.8	108.3	103.7	96.6 *	92.7 *	90.8 *
	Average				128.8	126.7	122.0	117.8	112.7	107.1	102.4	96.2	91.3
13	1	1527.5	76.4	125.5	124.3	120.6	115.2	114.6	111.0	107.2	105.6	102.6	100.0
	2	1537.5	76.9	125.5	126.1	123.1	119.6	116.3	113.3	111.0	109.0	106.2	103.8
	3	1525.0	76.3	125.0	123.0	120.1	114.7	111.0	107.7	105.0	102.2	99.7	97.3
	4	1520.0	76.0	126.9	125.8	123.1	118.3	115.1	111.0	108.0	105.2	102.1	99.9
	Average				125.8	125.0	121.9	117.4	114.6	111.2	108.3	106.2	103.3
14	1	1527.5	76.4	123.5	123.2	121.3	117.9	115.1	111.1	109.0	107.0	103.9	102.0
	2	1537.5	76.9	128.0	126.3	123.2	119.9	117.2	114.2	111.1	108.2	106.3	104.1
	3	1527.5	76.4	123.4	121.2	119.9	115.8	113.6	109.5	106.5	104.7	101.3	100.2
	4												
	Average				125.5	124.1	121.7	118.2	115.6	112.1	109.3	106.9	104.3

* adjusted for Broadband Contributions

NA Not Available

TABLE A.1 (CONTINUED)

EXTERIOR FLUSH-MOUNTED MICROPHONE : PORT SIDE

Test Condition	Flight Number	RPM	BPF Hz	Harmonic Level, dB re 20 micro Pa										
				1	2	3	4	5	6	7	8	9	10	
15	1	1527.5	76.4											
	2	1537.5	76.9	126.9	125.0	124.0	120.2	117.1	113.7	110.2	108.3	106.8	104.9	
	3	1527.5	76.4	122.3	123.4	120.0	116.8	113.1	110.3	107.4	105.2	102.0	99.9	
	4													
	Average			125.2	124.3	122.4	118.8	115.5	112.3	109.0	107.0	105.0	103.1	
16	1	1527.5	76.4											
	2	1540.0	77.0	125.8	127.4	124.3	122.2	117.3	115.8	113.0	111.2	108.2	105.7	
	3	1527.5	76.4	125.0	123.1	120.1	115.0	113.0	110.0	107.0	104.5	101.7	98.7	
	4													
	Average			125.4	125.8	122.7	119.9	115.7	113.8	111.0	109.0	106.1	103.5	
17	1	1572.5	78.6											
	2	1570.0	78.5	126.0	126.5	125.2	122.0	118.1	116.2	114.0	111.1	109.4	106.3	
	3	1570.0	78.5	123.4	123.4	121.5	118.1	114.5	111.7	109.1	106.3	104.6	101.5	
	4	1570.0	78.5	126.2	127.1	125.2	121.6	118.1	115.0	112.6	110.1	108.1	105.0	
	Average			125.4	125.9	124.3	120.9	117.2	114.7	112.3	109.6	107.8	104.7	
18	1	1522.5	76.1											
	2	1522.5	76.1	126.5	126.0	123.7	119.0	116.1	113.6	111.0	108.9	105.8	103.1	
	3	1520.0	76.0	123.9	122.3	120.0	115.8	112.5	109.0	106.4	103.5	100.2	98.0	
	4	1517.5	75.9	126.9	125.8	123.0	119.0	116.6	113.2	110.1	107.2	103.9	101.7	
	Average			126.0	125.0	122.5	118.2	115.4	112.4	109.6	107.1	103.9	101.4	

* adjusted for Broadband Contributions

NA Not Available

TABLE A.2

EXTERIOR FLUSH-MOUNTED MICROPHONE : STARBOARD SIDE

Test Condition	Flight Number	RPM	BPF Hz	Harmonic Level, dB re 20 micro Pa										
				1	2	3	4	5	6	7	8	9	10	
1	1	1525.0	76.3	131.0	127.5	122.5	116.0	110.8	104.8 *	99.5 *				
	2	1520.0	76.0	129.4	126.4	120.6	114.2	109.4	104.6 *	103.5 *	103.4 *	102.6 *	102.4 *	
	3	1520.0	76.0	129.5	126.5	120.7	114.5	109.4	104.6 *	103.2 *	102.4 *	102.1 *	101.3 *	
	4	1520.0	76.0	130.1	127.2	121.0	116.0	111.4	106.1 *	102.3 *	102.3 *	101.9 *	100.8 *	
	Average			130.0	126.9	121.3	115.3	110.3	105.1	102.4	102.7	102.2	101.6	
2	1	1570.0	78.5	130.2	128.0	122.4	116.5	109.8 *	107.8 *	108.1 *	109.4 *	108.6 *	107.6 *	
	2	1570.0	78.5	128.0	126.1	120.3	113.0	106.2 *	108.2	108.7	109.0	108.5	106.8	
	3	1572.5	78.6	128.5	126.2	120.9	113.0	106.7 *	106.1 *	108.5	109.2	108.7	106.6 *	
	4	1570.0	78.5	129.0	126.8	120.6	113.9	107.4 *	108.4 *	109.8 *	110.5	110.1	108.6 *	
	Average			129.0	126.8	121.1	114.4	107.8	107.7	108.8	109.6	109.0	107.5	
3	1	1570.0	78.5	129.8	128.3	123.0	119.0	115.0	110.6	106.0	100.1 *	96.0 *		
	2	1570.0	78.5	127.7	126.6	120.9	117.8	113.0	110.0	103.2 *	99.6 *	96.9 *		
	3	1570.0	78.5	127.6	126.3	120.5	117.0	112.1	109.0	102.7 *	100.3 *	92.6 *		
	4	1572.5	78.6	128.5	127.1	122.3	118.3	114.2	109.4	104.6 *	101.2 *	97.5 *		
	Average			128.5	127.1	121.8	118.1	113.7	109.8	104.3	100.3	96.1	NA	
4	1	1517.5	75.9	130.0	127.1	121.2	117.5	113.2	108.5	102.6 *	98.3 *			
	2	1520.0	76.0	128.5	126.0	120.3	116.4	112.9	107.4	101.2 *	97.8 *			
	3	1520.0	76.0	128.5	125.9	120.1	115.3	112.4	106.8	100.9 *	97.1 *			
	4	1517.5	75.9	129.0	126.2	120.7	116.3	112.7	107.2	101.0 *	99.4 *			
	Average			129.0	126.3	120.6	116.4	112.8	107.5	101.5	98.2	NA	NA	
5	1	1532.5	76.6											
	2	1530.0	76.5	125.5	126.0	119.4	117.6	113.0	109.1	104.0	99.5 *	93.3 *		
	3	1530.0	76.5	126.1	126.2	120.0	117.4	113.0	108.5	103.7	97.7 *	91.4 *		
	4													
	Average			125.8	126.1	119.7	117.5	113.0	108.8	103.9	98.7	92.5	NA	
6	1	1530.0	76.5	128.1	126.6	122.0	119.1	115.8	111.1	106.0	99.9 *	98.0 *		
	2	1532.5	76.6	125.8	124.5	120.9	116.6	114.0	108.8	105.0	100.1 *	94.8 *		
	3	1532.5	76.6	127.0	125.2	121.0	118.0	115.2	109.0	105.7	100.7 *	94.5 *		
	4													
	Average			127.1	125.5	121.3	118.0	115.1	109.8	105.6	100.2	96.1	NA	
7	1	1530.0	76.5	130.1	127.6	121.6	118.3	114.5	111.1	106.0	102.0 *	98.6 *		
	2	1530.0	76.5	128.0	126.0	121.0	116.8	113.5	108.5	104.9	99.7 *	98.0 *		
	3	1530.0	76.5	128.8	126.8	120.6	117.3	113.3	109.0	103.9	99.6 *	94.0 *		
	4													
	Average			129.1	126.8	121.1	117.5	113.8	109.7	105.0	100.6	97.3	NA	

* adjusted for Broadband Contributions

NA Not Available

TABLE A.2 (CONTINUED)

EXTERIOR FLUSH-MOUNTED MICROPHONE : STARBOARD SIDE

Test Condition	Flight Number	RPM	BPF Hz	Harmonic Level, dB re 20 micro Pa									
				1	2	3	4	5	6	7	8	9	10
8	1	1530.0	76.5	127.9	127.7	121.6	119.3	114.3	110.5	105.0	100.7 *	95.5 *	
	2	1532.5	76.6	125.8	125.5	120.3	117.1	112.9	108.3	103.4	97.6 *	93.5 *	
	3	1530.0	76.5	127.1	126.4	120.8	118.0	113.9	109.0	104.3	97.4 *	94.2 *	
	4												
	Average			127.0	126.6	120.9	118.2	113.7	109.4	104.3	98.8	94.5	NA
9	1	1520.0	76.0	129.5	127.3	122.0	118.5	114.9	110.2	104.4	101.2 *	96.5 *	
	2	1520.0	76.0	127.0	124.9	120.4	116.6	113.1	108.4	103.0	99.6 *	94.8 *	
	3	1520.0	76.0	128.0	125.9	120.8	117.5	113.6	108.4	103.0	98.6 *	95.0 *	
	4	1530.0	76.5	127.5	126.2	120.8	117.7	113.3	109.9	104.2	100.8 *	95.5 *	
	Average			128.1	126.2	121.0	117.6	113.8	109.3	103.7	100.2	95.5	NA
10	1	1572.5	78.6	129.0	127.9	123.5	119.7	116.3	112.0	107.4	102.7 *	99.7 *	96.3 *
	2	1570.0	78.5	126.3	125.2	120.8	117.6	114.0	110.7	106.0	102.4	98.2 *	95.6 *
	3	1572.5	78.6	127.8	126.7	122.0	118.3	115.2	110.6	106.5	101.9 *	99.5 *	95.6 *
	4	1572.5	78.6	128.1	126.4	122.8	118.5	115.9	112.1	106.5	104.0	99.2 *	98.3 *
	Average			127.9	126.7	122.4	118.6	115.4	111.4	106.6	102.8	99.2	96.6
11	1	1515.0	75.8	130.0	126.1	122.0	117.7	113.2	107.0	102.5	97.1	94.8 *	92.2 *
	2	1515.0	75.8	127.8	124.6	120.0	116.1	111.5	106.4	100.0	96.4	94.2 *	92.9 *
	3	1515.0	75.8	128.5	125.2	121.2	116.7	111.1	106.0	101.4	99.4	95.7 *	93.7 *
	4	1515.0	75.8	128.6	125.5	121.4	117.0	111.7	106.1	101.8	100.3	96.5 *	92.3 *
	Average			128.8	125.4	121.2	116.9	112.0	106.4	101.5	98.6	95.4	92.8
12	1	1520.0	76.0	112.5	102.8 *	93.2 *							
	2	1520.0	76.0	109.6	100.0 *	91.3 *							
	3	1520.0	76.0	110.2	101.4 *	93.6 *							
	4	1520.0	76.0										
	Average			111.0	101.5	92.8	NA	NA	NA	NA	NA	NA	NA
13	1	1527.5	76.4	127.3	126.0	123.0	119.5	117.6	114.0	109.7	108.2	104.9	101.3
	2	1537.5	76.9	124.8	123.8	120.5	118.2	116.2	113.2	110.3	107.7	105.0	100.7
	3	1525.0	76.3	126.0	123.9	121.2	118.8	115.1	112.1	108.8	106.2	103.1	99.5
	4	1520.0	76.0	125.9	124.8	121.5	119.1	114.6	110.7	107.7	106.0	102.9	99.0
	Average			126.1	124.7	121.6	118.9	116.0	112.7	109.2	107.1	104.1	100.2
14	1	1527.5	76.4	125.8	126.6	122.9	120.2	117.7	113.7	111.0	108.1	104.8	102.2
	2	1537.5	76.9	125.9	124.9	121.4	118.5	116.0	112.9	110.1	107.9	104.9	101.0
	3	1527.5	76.4	124.4	125.0	121.6	118.5	115.9	112.3	109.3	107.0	102.6	100.2
	4												
	Average			125.4	125.6	122.0	119.1	116.6	113.0	110.2	107.7	104.2	101.2

* adjusted for Broadband Contributions

NA Not Available

TABLE A.2 (CONTINUED)

EXTERIOR FLUSH-MOUNTED MICROPHONE : STARBOARD SIDE

Test Condition	Flight Number	RPM	BPF Hz	Harmonic Level, dB re 20 micro Pa									
				1	2	3	4	5	6	7	8	9	10
15	1	1527.5	76.4	127.1	126.0	122.8	119.3	117.5	114.1	109.8	108.2	104.7	101.2
	2	1537.5	76.9	124.5	125.1	121.2	119.0	116.0	113.5	110.3	107.8	104.7	101.6
	3	1527.5	76.4	125.0	124.1	121.2	118.0	116.1	112.4	109.2	107.2	103.0	100.4
	4												
	Average			125.7	125.1	121.8	118.8	116.6	113.4	109.8	107.8	104.2	101.1
16	1	1527.5	76.4	126.7	126.0	122.7	120.2	117.5	114.0	111.1	108.1	105.0	102.2
	2	1540.0	77.0	124.9	124.0	121.4	119.5	117.2	114.0	111.0	108.1	105.6	102.6
	3	1527.5	76.4	126.0	124.8	121.3	118.1	116.1	113.0	109.0	106.7	103.9	99.8
	4												
	Average			125.9	125.0	121.8	119.4	117.0	113.7	110.5	107.7	104.9	101.7
17	1	1517.5	75.9	126.7	125.8	122.2	119.1	116.2	113.4	110.0	107.2	103.6	101.0
	2	1517.5	75.9	124.6	123.7	120.2	117.8	115.5	112.4	109.0	106.0	102.6	100.3
	3	1517.5	75.9	125.3	123.4	120.4	117.3	115.0	111.5	108.5	105.9	102.2	98.2
	4	1517.5	75.9	125.3	124.1	120.7	117.2	114.1	111.1	108.0	105.7	102.0	99.0
	Average			125.5	124.4	121.0	117.9	115.3	112.2	108.9	106.2	102.6	99.8
18	1	1575.0	78.8	127.1	126.4	124.0	121.5	119.0	116.0	114.0	111.1	108.1	105.1
	2	1572.5	78.6	124.3	124.8	121.9	119.5	118.3	115.0	113.2	110.2	107.8	105.3
	3	1570.0	78.5	125.3	125.6	122.2	120.4	118.1	114.8	112.8	109.2	107.5	103.6
	4	1572.5	78.6	125.4	125.0	122.5	119.8	117.4	115.0	111.8	109.3	107.1	103.2
	Average			125.6	125.5	122.7	120.4	118.2	115.2	113.0	110.0	107.6	104.4

* adjusted for Broadband Contributions

NA Not Available

APPENDIX B

Interior Sound Pressure Levels at Harmonics of Propeller Blade
Passage Frequency: Flights 1 through 3, Bare Interior.

TABLE B.1

CABIN MICROPHONE NUMBER 1 : PORT ENGINE COMPONENTS

Test Condition	Flight Number	RPM	BPF Hz	Harmonic Level, dB re 20 micro Pa										
				1	2	3	4	5	6	7	8	9	10	
1	1	1580.0	79.0	112.2	97.7	86.7		69.4				65.0 *	67.0 *	54.2 *
	2	1572.5	78.6	112.2	95.7	92.8	77.4	76.2	79.2	73.1	61.5 *			
	3	1572.5	78.6	111.5	93.5	89.2	70.3 *	67.5 *			65.7 *		63.0 *	
	Average			112.0	96.0	90.3	75.2	72.7	79.2	70.8	63.6	65.4	54.2	
2	1	1525.0	76.3	110.1	94.7	92.0	77.7	67.8	64.2 *	63.0 *	59.9 *		61.8 *	
	2	1525.0	76.3	109.9	92.0	83.8	75.8	70.3			61.9 *		59.3 *	
	3	1525.0	76.3	109.6	92.6	86.0	67.2 *	61.5 *	67.2 *	64.2 *				
	Average			109.9	93.3	88.7	75.3	67.8	66.0	63.6	61.0	NA	60.7	
3	1	1527.5	76.4	110.6	88.8	75.5	85.3	81.1	80.1	73.7	67.2 *		58.6 *	
	2	1525.0	76.3	111.0	86.4	75.8	88.9	74.4	80.2	77.7	66.8 *		65.2 *	
	3	1525.0	76.3	110.2	82.1	78.3	86.8	65.9 *	77.1 *	74.6 *	69.5 *			
	Average			110.6	86.6	76.7	87.3	77.3	79.4	75.7	68.0	NA	63.0	
4	1	1572.5	78.6	113.5	88.1	81.3	89.5	88.3	70.0 *	67.2 *	63.3 *		61.7 *	
	2	1572.5	78.6	113.0	83.2	84.8	90.6	81.0		64.9 *		64.1 *		
	3	1572.5	78.6	113.7	80.5	83.7	91.5	81.5	78.5 *	68.5 *				
	Average			113.4	85.1	83.5	90.6	85.0	76.1	67.1	63.3	64.1	61.7	
9	1	1572.5	78.6	113.7	86.4	79.0	89.6	75.9	80.7	78.7	62.9 *	75.8		
	2	1575.0	78.8	113.2	92.6	85.2	90.6	68.9	75.7 *	82.1	72.9 *	72.8 *		
	3	1572.5	78.6	113.6	92.9	83.7	87.7	70.0 *	77.8 *	81.5	69.8 *	66.6 *		
	Average			113.5	91.5	83.3	89.5	72.8	78.6	81.0	70.1	73.1	NA	
10	1	1525.0	76.3	110.3	93.4	75.8	85.0	71.7	80.7	78.2	70.1 *		62.0 *	
	2	1525.0	76.3	111.0	93.9	87.8	85.4	79.3	82.0	72.9 *	65.8 *			
	3	1525.0	76.3	110.1	92.7	86.9	84.8	78.8	82.9	76.2	65.2 *		62.2 *	
	Average			110.5	93.4	85.8	85.1	77.7	82.0	76.3	67.6	NA	62.1	
12	1	1520.0	76.0	109.0	88.5	72.1	86.1	68.0	78.0	70.2	58.6 *	68.3	51.5 *	
	2	1520.0	76.0	109.3	87.1	80.1	79.7	73.6	78.0	71.2	58.2 *	59.1 *	54.9 *	
	3	1520.0	76.0	109.3	81.1	82.5	81.7	72.6	77.0	72.4	56.8 *	57.7 *	60.5 *	
	Average			109.2	86.5	79.9	83.3	72.0	77.7	71.4	57.9	64.3	57.2	
17	1	1572.5	78.6	107.0	83.8	88.0	79.5	78.5	82.3	75.7	74.3	78.3	60.1 *	
	2	1570.0	78.5	106.7	90.7	88.9	76.3	76.2	81.7	73.9	76.4	76.4	67.1	
	3	1570.0	78.5	105.9	84.7	89.9	73.9	74.9	86.2	75.0	72.3	70.5	58.0 *	
	Average			106.6	87.6	89.0	77.2	76.8	83.9	74.9	74.7	76.1	63.5	
18	1	1522.5	76.1	102.2	89.7	90.3	74.6	77.9	75.2	74.3	69.8	78.0	60.7 *	
	2	1522.5	76.1	103.4	91.6	92.0	76.5	81.5	65.5 *	74.1	69.5	79.2	54.0 *	
	3	1520.0	76.0	102.6	90.4	92.9	76.0	76.1		76.1	69.3		55.8 *	
	Average			102.8	90.6	91.9	75.8	79.1	72.6	74.9	69.5	78.6	57.8	

* adjusted for Broadband Contributions

NA Not Available

TABLE B.2

CABIN MICROPHONE NUMBER 1 : STARBOARD ENGINE COMPONENTS

Test Condition	Flight Number	RPM	BPF Hz	Harmonic Level, dB re 20 micro Pa									
				1	2	3	4	5	6	7	8	9	10
1	1	1525.0	76.3	103.4	96.7	94.3	83.5	68.2	63.1 *	64.0 *	55.2 *		
	2	1520.0	76.0	103.6	96.7	95.1	84.2	71.5		72.0			
	3	1520.0	76.0	103.1	95.1	96.3	84.0	72.4	68.1 *	68.0 *			
	Average			103.4	96.2	95.3	83.9	71.0	66.3	69.2	55.2	NA	NA
2	1	1570.0	78.5	105.4	95.2	91.6	84.9	77.9	66.1 *	56.0 *	59.1 *	56.6 *	
	2	1570.0	78.5	104.6	96.2	98.5	80.4	73.2		67.3 *	58.2 *		
	3	1572.5	78.6	104.1	92.3	90.5	80.5	76.2	67.5 *				
	Average			104.7	94.9	95.1	82.5	76.2	66.9	64.6	58.7	56.6	NA
3	1	1570.0	78.5	106.9	99.4	87.5	86.7	79.7	62.5 *		67.0 *		
	2	1570.0	78.5	107.2	98.5	90.2	87.9	80.5		64.8 *	69.7 *	61.2 *	
	3	1570.0	78.5	105.2	95.8	89.8	88.4	76.4	72.1 *	65.2 *	66.9 *	63.1 *	
	Average			106.5	98.1	89.3	87.7	79.2	69.5	65.0	68.1	62.3	NA
4	1	1517.5	75.9	104.8	99.6	86.6	82.1	75.7	68.2 *	61.1 *	64.5 *		60.0 *
	2	1520.0	76.0	104.8	99.0	88.7	82.3	79.3	67.8 *	70.5 *	63.0 *		
	3	1520.0	76.0	103.8	96.6	89.5	83.3	70.8 *		68.0 *			
	Average			104.5	98.6	88.4	82.6	76.5	68.0	68.0	63.8	NA	60.0
9	1	1520.0	76.0	102.0	95.6	87.0	86.2	77.7	76.3 *	71.2 *	68.9 *		57.3 *
	2	1520.0	76.0	102.3	92.4	89.4	89.2	78.3	72.5 *	64.3 *	66.4 *		
	3	1520.0	76.0	102.5	91.1	89.5	85.7	69.5 *	78.4 *				
	Average			102.3	93.5	88.8	87.3	76.5	76.4	69.0	67.8	NA	57.3
10	1	1572.5	78.6	105.4	98.3	84.8	88.6	86.6	79.4	72.3 *	67.6 *	68.3 *	
	2	1570.0	78.5	105.3	95.8	87.5	88.9	81.8	81.1	68.2 *	70.3 *	63.7 *	57.9 *
	3	1572.5	78.6	106.7	94.7	89.0	89.7	81.2	78.2 *	72.7 *	67.0 *		
	Average			105.8	96.5	87.4	89.1	83.9	79.7	71.5	68.5	66.6	57.9
11	1	1515.0	75.8	101.2	85.3	83.8	82.0	76.1	80.9	70.5	57.7 *	59.7 *	60.9 *
	2	1515.0	75.8	102.0	86.4	85.0	84.7	73.3	77.7	64.1 *		63.4 *	50.2 *
	3	1515.0	75.8	100.9	83.1	88.2	79.9	65.1 *	82.9	72.2	66.0 *	62.5 *	63.7 *
	Average			101.4	85.1	86.1	82.6	73.4	81.0	70.1	63.6	62.1	60.9
17	1	1517.5	75.9	94.3	88.3	87.2	83.8	77.4	81.8	78.0	73.0	71.0	58.5 *
	2	1517.5	75.9	96.4	87.7	90.3	83.5	75.1	78.9	60.1 *	71.0 *	63.5 *	60.6 *
	3	1517.5	75.9	94.4	89.5	89.3	72.3	73.0	82.4	76.1	70.0	66.0 *	
	Average			95.1	88.6	89.1	82.0	75.5	81.3	75.4	71.5	68.0	59.7
18	1	1575.0	78.8	99.0	94.6	87.2	91.4	83.6	89.3	78.1	72.3	69.5	67.6
	2	1572.5	78.6	98.5	95.8	89.7	89.2	86.3	89.0	81.2	72.1	71.1	68.9
	3	1570.0	78.5	99.6	94.8	89.0	83.0	83.7	81.8	75.1	69.7	62.0 *	67.1
	Average			99.1	95.1	88.8	89.1	84.7	87.8	78.8	71.5	68.9	67.9

* adjusted for Broadband Contributions

NA Not Available

TABLE B.3

CABIN MICROPHONE NUMBER 1 : PORT & STARBOARD ENGINE COMPONENTS

Test Condition	Flight Number	RPM	BPF Hz	Harmonic Level, dB re 20 micro Pa									
				1	2	3	4	5	6	7	8	9	10
5	1	1532.5	76.6	111.3	93.3	87.3	92.3	81.1	79.3	69.4 *	66.8 *	66.6 *	
	2	1530.0	76.5	110.8	83.2	84.2	90.3	82.6	84.2	70.3 *	67.2 *	72.8	60.8 *
	3	1530.0	76.5	111.7	91.4	85.4	81.4	73.4	86.8	75.2	71.4 *		66.4 *
	Average			111.3	90.9	85.8	89.9	80.4	84.4	72.4	69.0	70.7	64.4
6	1	1530.0	76.5	107.8	100.5	82.8	90.5	82.1	87.2	81.3	65.4 *	72.8	60.3
	2	1532.5	76.6	107.6	99.5	91.5	87.9	81.1	79.9	78.0	72.6 *	70.4 *	62.0 *
	3	1532.5	76.6	107.6	98.8	91.4	90.3	80.8	85.6	79.0	64.4 *	66.1 *	67.8 *
	Average			107.7	99.7	90.0	89.7	81.4	85.2	79.7	69.1	70.6	64.6
7	1	1530.0	76.5	113.6	97.3	87.4	87.8	76.9	86.2	79.8	70.3 *	65.8 *	
	2	1530.0	76.5	113.6	92.0	92.1	92.2	74.9	81.5	77.2	64.8 *	71.2 *	58.3 *
	3	1530.0	76.5	114.0	92.7	93.0	90.3	80.0	86.0	74.4 *	67.0 *	66.0 *	68.8 *
	Average			113.7	94.7	91.4	90.5	77.8	85.0	77.7	68.0	68.4	66.2
8	1	1530.0	76.5	112.5	93.0	87.7	81.9	78.2	86.1	79.3	74.8	68.2 *	66.7 *
	2	1532.5	76.6	113.1	93.9	90.3	87.9	79.1	85.1	76.0	69.0 *	70.0 *	58.1 *
	3	1530.0	76.5	113.0	96.7	93.0	83.3	82.0	84.0	76.1	67.2 *		
	Average			112.9	94.8	90.9	85.2	80.1	85.2	77.4	71.6	69.2	64.3
13	1	1527.5	76.4	105.2	97.2	88.5	84.4	80.9	83.6	78.0	75.4	74.6	65.1
	2	1537.5	76.9	102.0	95.1	89.3	86.3	79.0	90.4	81.9	75.1	76.1	66.2
	3	1525.0	76.3	104.7	99.0	86.3	83.1	80.4	79.0	83.1	70.0	63.4 *	58.7 *
	Average			104.2	97.4	88.2	84.8	80.2	86.7	81.5	74.1	73.8	64.3
14	1	1527.5	76.4	103.1	88.1	90.5	84.9	80.3	83.9	84.1	75.3	72.6	69.0
	2	1537.5	76.9	106.6	97.0	93.2	85.9	84.0	91.2	81.4	77.1	73.7	65.3
	3	1527.5	76.4	103.3	83.7	91.7	83.1	74.0	79.1	81.0	72.0	67.2 *	60.5 *
	Average			104.6	92.9	91.9	84.8	81.1	87.4	82.4	75.3	71.9	66.2
15	1	1527.5	76.4	102.9	85.7	90.6	81.9	83.8	82.1	82.2	71.2	76.0	63.0 *
	2	1537.5	76.9	104.2	84.7	89.4	88.1	77.8	92.5	82.9	75.3	76.0	66.1
	3	1527.5	76.4	99.2	95.1	90.6	83.1	76.7	81.1	81.0	68.0 *	64.6 *	60.6 *
	Average			102.6	91.1	90.2	85.2	80.6	88.4	82.1	72.5	74.4	63.8
16	1	1527.5	76.4	105.9	95.8	90.7	86.6	79.9	83.0	82.0	77.1	72.0	68.7
	2	1540.0	77.0	101.4	97.5	93.5	85.9	83.7	92.3	82.5	73.9	75.1	68.3
	3	1527.5	76.4	105.2	97.9	91.6	78.5	81.9	82.2	80.0	71.5	67.5 *	60.9 *
	Average			104.6	97.2	92.1	84.9	82.1	88.4	81.6	74.8	72.5	67.1

* adjusted for Broadband Contributions

NA Not Available

TABLE B.4

CABIN MICROPHONE NUMBER 2 : PORT ENGINE COMPONENTS

Test Condition	Flight Number	RPM	BPF Hz	Harmonic Level, dB re 20 micro Pa										
				1	2	3	4	5	6	7	8	9	10	
1	1	1580.0	79.0	112.2	93.8	90.7	76.2 *	74.6 *	73.9 *	69.7 *				
	2	1572.5	78.6	111.7	93.2	87.6	86.8	77.8	78.9	63.1 *	71.2 *	63.3 *	61.1 *	
	3	1572.5	78.6	111.6	91.5	89.4	87.4	75.7	76.2	64.6 *	70.0 *	64.5 *		
	Average			111.8	92.9	89.4	85.5	76.2	76.8	66.8	70.6	63.9	61.1	
2	1	1525.0	76.3	110.6	89.2	85.4	78.3 *	65.4 *	74.6 *	64.3 *	68.8 *			
	2	1525.0	76.3	109.9	86.9	83.7	85.5	72.2 *	71.8 *		72.4 *			
	3	1525.0	76.3	110.2	82.5	85.7	83.0	70.7 *	70.8 *		70.2 *			
	Average			110.2	87.0	85.0	83.2	70.3	72.7	64.3	70.7	NA	NA	
3	1	1527.5	76.4	110.9	96.5	95.2	85.9	83.5	77.7 *	70.6 *			68.4 *	
	2	1525.0	76.3	110.9	97.0	93.6	88.1	84.4	71.7 *					
	3	1525.0	76.3	110.9	94.8	91.4	89.6	81.7	70.0 *					
	Average			110.9	96.2	93.7	88.1	83.3	74.5	70.6	NA	NA	68.4	
4	1	1572.5	78.6	112.9	95.1	94.5	94.6	87.5	82.1	69.4 *		68.0 *		
	2	1572.5	78.6	112.5	94.6	92.4	95.1	83.1	84.7	72.6 *	69.4 *	69.8 *		
	3	1572.5	78.6	113.7	92.9	93.0	96.2	86.2	82.3	77.0	70.7 *	72.0 *		
	Average			113.1	94.3	93.4	95.4	86.0	83.2	74.1	70.1	70.2	NA	
9	1	1572.5	78.6	112.8	96.7	94.4	92.7	85.0	84.3	73.6 *		69.6 *		
	2	1575.0	78.8	112.3	96.9	92.8	91.7	87.2	90.0	75.8	69.5 *	74.2	70.9 *	
	3	1572.5	78.6	113.2	99.4	92.8	90.8	86.8	88.0	75.6 *	66.8 *	75.3	64.8 *	
	Average			112.8	97.8	93.4	91.8	86.4	88.0	75.1	68.4	73.6	68.8	
10	1	1525.0	76.3	110.3	99.1	95.6	83.7	76.4	79.1 *	71.9 *			67.1 *	
	2	1525.0	76.3	110.4	98.7	93.6	71.4 *	84.7	85.0	73.7 *	71.9 *		71.2 *	
	3	1525.0	76.3	110.2	98.8	92.4	78.6	82.4	84.2	71.5 *	72.7 *		67.6 *	
	Average			110.3	98.9	94.1	80.3	82.3	83.4	72.5	72.3	NA	69.0	
12	1	1520.0	76.0	109.1	97.2	93.3	84.9	72.0	71.0 *	67.0 *		62.1 *	62.5 *	
	2	1520.0	76.0	109.0	96.8	89.1	83.0	77.7	78.3	71.2	62.5 *			
	3	1520.0	76.0	109.6	96.5	89.8	84.3	74.6	79.8	70.9	66.3 *	59.1 *	63.5 *	
	Average			109.2	96.8	91.1	84.1	75.4	77.7	70.1	64.8	60.9	63.0	
17	1	1572.5	78.6	105.7	92.3	87.6	81.6	86.6	89.0	84.6	74.9	73.3	75.0	
	2	1570.0	78.5	105.1	90.3	84.2	83.8	84.4	89.1	82.8	71.9	72.5	77.1	
	3	1570.0	78.5	104.9	91.6	88.3	83.9	81.7	89.6	82.7	70.0	73.3	74.2	
	Average			105.2	91.5	87.0	83.2	84.7	89.2	83.5	72.7	73.0	75.6	
18	1	1522.5	76.1	101.9	93.9	83.0	87.2	82.1	86.0	73.9	68.5 *		65.5 *	
	2	1522.5	76.1	102.2	94.5	82.8	87.1	79.4	85.0	73.9	70.8		63.3 *	
	3	1520.0	76.0	102.3	94.1	70.3	84.8	83.3	82.4	70.5	69.8 *		62.9 *	
	Average			102.1	94.2	81.3	86.5	81.9	84.7	73.0	69.8	NA	64.1	

* adjusted for Broadband Contributions

NA Not Available

TABLE B.5

CABIN MICROPHONE NUMBER 2 : STARBOARD ENGINE COMPONENTS

Test Condition	Flight Number	RPM	BPF Hz	Harmonic Level, dB re 20 micro Pa										
				1	2	3	4	5	6	7	8	9	10	
1	1	1525.0	76.3	102.7	90.1	81.5	82.7	78.2						
	2	1520.0	76.0	102.2	91.1	80.6	79.3	80.2						
	3	1520.0	76.0	102.4	89.4	78.6	82.9	79.7						
	Average			102.4	90.3	80.4	81.9	79.4	NA	NA	NA	NA	NA	
2	1	1570.0	78.5	104.3	91.8	84.9	88.0	78.8	69.7 *					
	2	1570.0	78.5	103.3	92.4	85.9	80.3	81.2		70.1 *	65.0 *			
	3	1572.5	78.6	103.2	93.4	85.0	79.9	76.5		65.2 *				
	Average			103.6	92.6	85.3	84.4	79.2	69.7	68.3	65.0	NA	NA	
3	1	1570.0	78.5	105.9	92.6	74.2	86.8	83.4	70.2 *	72.5 *	67.3 *			
	2	1570.0	78.5	105.5	93.7	80.7	87.5	74.6 *	79.9 *	65.3 *				
	3	1570.0	78.5	104.1	94.0	70.3	86.7	82.0	75.9 *			64.1 *		
	Average			105.2	93.5	77.1	87.0	81.3	76.9	70.2	67.3	64.1	NA	
4	1	1517.5	78.9	103.6	95.7	86.6	85.2	80.5		65.5 *	68.5 *			
	2	1520.0	76.0	102.9	94.9	86.4	86.7	87.9						
	3	1517.5	75.9	102.0	93.6	84.5	85.5	81.0		66.7 *				
	Average			102.9	94.8	85.9	85.8	84.5	NA	66.1	68.5	NA	NA	
9	1	1520.0	76.0	98.7	92.7	89.1	89.5	84.8	79.7 *	64.9 *	68.2 *			
	2	1520.0	76.0	99.1	88.7	86.8	89.7	83.0	75.8 *		69.0 *			
	3	1520.0	76.0	99.7	91.9	88.2	88.8	77.9	82.1		69.4 *			
	Average			99.2	91.4	88.1	89.4	82.7	79.9	64.9	68.9	NA	NA	
10	1	1572.5	78.6	102.5	93.5	83.0	89.7	90.1	81.7					
	2	1570.0	78.5	102.7	92.7	85.9	87.8	87.6	82.6	67.9 *				
	3	1572.5	78.6	104.6	96.8	83.8	88.5	86.4	80.0	73.3 *		65.2 *		
	Average			103.4	94.7	84.4	88.7	88.3	81.6	71.4	NA	65.2	NA	
11	1	1515.0	75.8	99.5	90.2	81.5	83.8	84.6	80.9	66.2 *	63.4 *		67.9 *	
	2	1517.5	75.9	99.6	88.2	82.3	84.3	84.7	81.3	61.5 *	62.7 *	61.6 *	61.5 *	
	3	1515.0	75.8	98.3	87.9	85.1	82.0	79.3	82.1	59.0 *	59.5 *	64.4 *	60.6 *	
	Average			99.2	88.9	83.3	83.5	83.5	81.5	63.3	62.2	63.2	64.6	
17	1	1517.5	75.9	87.1	84.5	90.3	88.8	82.7	92.1	85.0	80.0	64.5 *		
	2	1517.5	75.9	89.8	89.8	90.3	86.8	82.0	90.6	83.1	76.4	65.8 *	61.5 *	
	3	1517.5	75.9	89.6	89.1	85.9	84.2	69.2	87.2	80.0	77.0		56.5 *	
	Average			89.0	88.3	89.3	87.0	80.7	90.4	83.2	78.1	65.2	59.7	
18	1	1575.0	78.8	95.3	87.0	87.0	91.7	84.1	90.4	82.7	80.0	69.6 *	64.2 *	
	2	1572.5	78.6	94.4	89.8	82.7	88.1	87.5	90.0	81.3	80.2	66.0 *	70.8	
	3	1570.0	78.5	96.5	89.0	83.2	87.3	86.3	88.3	72.8	75.0	73.1	68.9	
	Average			95.5	88.8	84.8	89.5	86.2	89.7	80.5	79.0	70.5	68.7	

* adjusted for Broadband Contributions

NA Not Available

TABLE B.6

CABIN MICROPHONE NUMBER 2 : PORT & STARBOARD ENGINE COMPONENTS

Test Condition	Flight Number	RPM	BPF Hz	Harmonic Level, dB re 20 micro Pa									
				1	2	3	4	5	6	7	8	9	10
5	1	1532.5	76.6	110.8	96.9	87.5	89.0	80.1	85.0	71.9 *	69.9 *	66.5 *	66.5 *
	2	1530.0	76.5	110.6	97.4	88.4	87.7	81.4	83.2	75.0	70.2 *		70.0 *
	3	1530.0	76.5	111.8	99.9	88.8	90.3	85.6	80.9	73.9 *	73.7 *		67.4 *
	Average			111.1	98.3	88.3	89.1	83.0	83.3	73.8	71.6	66.5	68.2
6	1	1530.0	76.5	108.8	101.3	95.1	89.8	87.6	86.0	78.1	75.6 *	65.9 *	65.2 *
	2	1532.5	76.6	108.2	98.7	93.9	87.4	76.2	87.7	76.1	67.5 *		
	3	1532.5	76.6	108.9	102.1	92.1	85.6	86.8	88.0	78.3	74.3 *		68.4 *
	Average			108.6	100.9	93.9	87.9	85.6	87.3	77.6	73.6	65.9	67.1
7	1	1530.0	76.5	112.8	92.1	93.8	88.1	82.4	82.7	72.9 *	76.2 *		69.5 *
	2	1530.0	76.5	112.5	96.4	96.5	87.7	88.7	87.5	74.0 *	76.0 *		71.1 *
	3	1530.0	76.5	113.4	95.7	95.1	84.6	81.9	88.6	73.0 *	78.7		67.9 *
	Average			112.9	95.1	95.3	87.1	85.5	86.9	73.3	77.1	NA	69.7
8	1	1530.0	76.5	112.3	101.1	93.6	85.9	88.7	78.7 *	71.1 *	71.7 *	67.7 *	67.3 *
	2	1530.0	76.5	112.0	100.3	93.4	88.5	89.3	85.7	73.3 *	73.2 *	66.8 *	69.4 *
	3	1530.0	76.5	112.7	103.4	95.6	89.1	85.4	88.1	69.8 *	73.0 *		65.8 *
	Average			112.3	101.8	94.3	88.0	88.1	85.6	71.6	72.7	67.3	67.8
13	1	1527.5	76.4	103.5	94.3	87.8	91.3	87.2	92.7	85.1	77.5	73.1	69.4 *
	2	1537.5	76.9	100.9	86.4	87.3	87.5	85.4	88.9	83.4	75.1	71.2	65.4 *
	3	1525.0	76.3	103.1	97.7	88.3	89.9	82.9	89.3	81.5	71.0	67.7	62.0 *
	Average			102.6	94.8	87.8	89.8	85.5	90.7	83.6	75.3	71.2	66.6
14	1	1527.5	76.4	103.4	94.3	87.0	92.8	83.2	92.1	83.0	80.0	68.7	60.8 *
	2	1537.5	76.9	104.1	96.2	86.7	84.1	77.4	85.8	81.2	78.8	73.0	59.0 *
	3	1527.5	76.4	103.4	91.4	84.4	92.0	84.3	83.9	79.6	78.5	68.1	63.9 *
	Average			103.6	94.4	86.2	91.0	82.5	88.7	81.5	79.1	70.5	61.7
15	1	1527.5	76.4	100.9	93.2	91.3	89.2	84.7	91.5	83.1	75.5	70.5	67.9
	2	1537.5	76.9	103.6	95.0	83.2	93.4	75.4	85.0	84.1	75.9	72.9	63.2 *
	3	1527.5	76.4	99.8	91.5	84.0	88.3	84.6	84.3	78.0	75.7	68.1	58.6 *
	Average			101.7	93.5	87.8	90.9	83.1	88.2	82.4	75.7	70.9	64.8
16	1	1527.5	76.4	104.3	92.8	90.3	92.8	85.1	92.1	82.6	78.4	70.4	66.7 *
	2	1540.0	77.0	101.2	92.4	86.1	91.1	84.2	85.8	85.0	77.1	75.3	64.2 *
	3	1527.5	76.4	103.3	98.3	86.5	87.5	82.3	86.5	80.1	75.4	69.1	58.0 *
	Average			103.1	95.4	88.1	91.0	84.0	89.1	83.0	77.1	72.5	64.2

* adjusted for Broadband Contributions

NA Not Available

TABLE B.7

CABIN MICROPHONE NUMBER 3 : PORT ENGINE COMPONENTS

Test Condition	Flight Number	RPM	BPF Hz	Harmonic Level, dB re 20 micro Pa											
				1	2	3	4	5	6	7	8	9	10		
1	1	1580.0	79.0	106.5	95.0	93.8	71.6 *	78.0							
	2	1572.5	78.6	105.8	89.9	95.0	80.0	76.8	69.9 *	72.2 *	68.8 *	68.1 *	68.0 *		
	3	1572.5	78.6	106.6	92.3	94.3	78.0	81.2	67.1 *	67.2 *					
	Average			106.3	92.9	94.4	77.7	79.1	68.7	70.4	68.8	68.1	68.0		
2	1	1525.0	76.3	103.6	89.5	98.1	80.8	79.5	73.2 *	68.9 *	71.2 *				
	2	1525.0	76.3	102.4	92.3	97.1	75.7	75.8	74.8 *						
	3	1525.0	76.3	103.2	89.3	95.6	73.4	77.2	68.4 *						
	Average			103.1	90.6	97.1	77.8	77.8	72.9	68.9	71.2	NA	NA		
3	1	1527.5	76.4	102.5	93.9	97.9	82.4	71.9 *		75.1 *					
	2	1525.0	76.3	100.1	98.7	97.0	83.7	81.2		75.6 *					
	3	1525.0	76.3	98.7	97.8	95.7	84.5	81.0	65.5 *	79.1	68.0 *				
	Average			100.7	97.2	97.0	83.6	79.6	65.5	77.0	68.0	NA	NA		
4	1	1572.5	78.6	99.7	87.1	98.7	76.8	77.7	78.0 *						
	2	1572.5	78.6	97.4	85.0	98.6	80.7	82.4	82.1	67.2 *	76.9 *				
	3	1572.5	78.6	94.2	84.5	98.7	81.6	84.4	78.0 *	68.3 *	77.0 *				
	Average			97.6	85.7	98.7	80.1	82.3	79.8	67.8	77.0	NA	NA		
9	1	1572.5	78.6	88.1	90.5	99.0	87.7	86.4	84.0	72.8 *	67.2 *	75.4 *			
	2	1575.0	78.8	86.8	91.1	97.2	89.0	83.6	73.6 *	81.1	70.3 *	81.8			
	3	1572.5	78.6	87.4	97.0	97.3	88.0	85.3	77.1 *	79.0	70.1 *	80.0			
	Average			87.5	93.9	97.9	88.3	85.2	80.4	78.8	69.4	79.8	NA		
10	1	1525.0	76.3	101.2	98.0	96.7	88.8	80.9	77.9 *	79.5 *					
	2	1525.0	76.3	101.1	99.6	93.4	88.3	82.9	85.7	76.9 *	74.3 *		68.9 *		
	3	1525.0	76.3	99.6	100.0	92.4	87.7	76.6	84.0	71.2 *	74.5 *				
	Average			100.7	99.3	94.6	88.3	80.8	83.6	77.0	74.4	NA	68.9		
12	1	1520.0	76.0	102.0	96.7	92.0	83.7	69.7	77.2	72.3 *					
	2	1520.0	76.0	101.5	96.2	84.1	72.1	76.8	80.5		70.3 *		66.4 *		
	3	1520.0	76.0	101.4	97.3	87.3	74.3	77.3	79.6	69.6 *	72.2 *	64.0 *	63.5 *		
	Average			101.6	96.8	89.0	79.7	75.7	79.3	71.2	71.4	64.0	65.2		
17	1	1572.5	78.6	97.0	96.5	84.5	82.8	72.4	90.3	79.4	81.3	82.9	75.2		
	2	1570.0	78.5	96.9	98.3	83.4	84.1	82.5	91.3	83.2	83.2	80.1	69.7 *		
	3	1570.0	78.5	96.2	95.6	82.4	84.6	73.6	90.0	75.3	76.4	76.2	68.9 *		
	Average			96.7	96.9	83.5	83.9	78.6	90.6	80.4	81.1	80.5	72.2		
18	1	1522.5	76.1	99.2	94.8	86.0	85.6	77.7	81.1	79.1	65.6 *		67.6 *		
	2	1522.5	76.1	98.7	95.0	83.8	84.5	73.8	81.0	76.3	67.3 *		65.3 *		
	3	1520.0	76.0	99.2	95.2	84.6	84.7	74.0	81.1	76.5	69.0 *		70.5 *		
	Average			99.0	95.0	84.9	85.0	75.6	81.1	77.5	67.5	NA	68.3		

* adjusted for Broadband Contributions

NA Not Available

TABLE B.8

CABIN MICROPHONE NUMBER 3 : STARBOARD ENGINE COMPONENTS

Test Condition	Flight Number	RPM	BPF Hz	Harmonic Level, dB re 20 micro Pa										
				1	2	3	4	5	6	7	8	9	10	
1	1	1525.0	76.3	93.5	98.3	98.7	81.0	81.3						
	2	1520.0	76.0	94.2	100.6	98.4	82.2	83.8	70.7 *	71.3 *	74.4 *			
	3	1520.0	76.0	91.7	97.7	99.5	85.9	84.2	72.8 *					
	Average			93.3	99.1	98.9	83.6	83.3	71.9	71.3	74.4	NA	NA	
2	1	1570.0	78.5	89.4	95.6	96.1	85.6	80.2	69.2 *	70.0 *				
	2	1570.0	78.5	89.6	97.3	101.5	90.0	83.5	73.6	72.0 *				
	3	1572.5	76.6	85.5	94.8	94.9	83.6	80.3	66.0 *	71.2 *				
	Average			88.5	96.0	98.5	87.2	81.6	70.7	71.1	NA	NA	NA	
3	1	1572.5	78.6	96.7	100.6	92.0	85.5	83.2	75.2 *	71.2 *				
	2	1570.0	78.5	98.0	99.9	94.7	85.3	89.6	82.0	70.2 *				
	3	1570.0	78.5	95.1	89.6	91.4	86.9	82.8	84.7	68.7 *	73.0 *			
	Average			96.8	98.7	92.9	86.0	86.4	82.1	70.2	73.0	NA	NA	
4	1	1517.5	75.9	98.1	100.9	93.8	81.8	89.2	76.9 *					
	2	1517.5	75.9	97.9	101.7	94.3	72.3	94.7	72.7 *					
	3	1517.5	75.9	98.4	96.5	94.0	75.0	89.3	73.7 *	68.2 *				
	Average			98.1	100.2	94.0	78.2	91.9	74.8	68.2	NA	NA	NA	
9	1	1520.0	76.0	102.5	99.2	95.1	85.8	91.7	82.9					
	2	1520.0	76.0	100.8	98.9	92.7	76.6	90.5	76.7					
	3	1520.0	76.0	100.3	97.3	92.4	79.2	83.1	73.5 *					
	Average			101.3	98.5	93.6	82.3	89.7	79.4	NA	NA	NA	NA	
10	1	1572.5	78.6	103.4	98.6	92.8	81.6	90.5	81.3	79.0				
	2	1570.0	78.5	99.6	98.1	93.4	84.0	84.9	81.4	79.7	67.3 *	68.2 *	67.9 *	
	3	1572.5	78.6	101.1	97.7	91.8	84.6	77.8	80.0	80.6				
	Average			101.7	98.1	92.7	83.6	87.0	80.9	79.8	67.3	68.2	67.9	
11	1	1515.0	75.8	95.2	94.7	90.9	79.9	88.8	86.0	68.2 *	71.9 *	65.5 *	71.7	
	2	1515.0	75.8	96.5	96.3	90.3	78.9	88.0	81.6	71.9	65.1 *	70.8 *		
	3	1515.0	75.8	99.7	92.9	91.1	83.1	81.0	79.0	71.4 *	70.8 *	63.7 *	64.0 *	
	Average			97.6	94.9	90.8	81.0	87.0	83.2	70.8	70.1	67.8	69.4	
17	1	1517.5	75.9	97.4	92.6	84.2	79.1	88.4	96.1	82.0	66.8 *	77.5		
	2	1517.5	75.9	96.3	91.8	85.7	72.3	89.8	97.3	85.1	82.2	74.1 *	72.5 *	
	3	1517.5	75.9	94.7	88.9	79.2	76.9	83.0	93.1	82.3	70.0 *	65.5 *		
	Average			96.3	91.4	83.8	76.9	87.9	95.8	83.4	77.8	74.5	72.5	
18	1	1575.0	78.8	98.8	93.4	86.5	78.6	86.0	92.5	91.2	85.2	79.0	73.1	
	2	1572.5	78.6	97.8	95.6	86.2	80.6	88.5	94.2	90.7	88.0	69.6 *	74.0	
	3	1570.0	78.5	98.3	93.2	85.3	78.3	85.9	91.3	89.7	85.3	79.2	75.1	
	Average			98.3	94.2	86.0	79.3	87.0	92.8	90.6	86.4	77.6	74.1	

* adjusted for Broadband Contributions

NA Not Available

TABLE B.9

CABIN MICROPHONE NUMBER 3 : PORT & STARBOARD ENGINE COMPONENTS

Test Condition	Flight Number	RPM	BPF Hz	Harmonic Level, dB re 20 micro Pa										
				1	2	3	4	5	6	7	8	9	10	
5	1	1532.5	76.6	105.2	101.4	92.2	91.1	91.6	83.0	77.9 *				
	2	1530.0	76.5	100.8	102.2	94.1	91.2	90.0	82.7	73.8 *	69.7 *	68.7 *	71.1 *	
	3	1530.0	76.5	100.8	101.2	86.2	79.1	87.5	87.1	72.2 *	73.7 *			
	Average				102.8	101.6	91.9	89.5	90.0	84.8	75.3	72.1	68.7	71.1
6	1	1530.0	76.5	108.3	99.8	97.1	91.1	91.8	85.0	76.9 *	70.5 *			
	2	1532.5	76.6	106.7	99.6	96.2	90.7	92.1	84.1	73.3 *	74.7 *	69.5 *	73.1 *	
	3	1532.5	76.6	106.5	103.0	95.2	90.3	87.6	84.4	75.1 *	75.8 *	67.2 *	72.1 *	
	Average				107.2	101.1	96.2	90.7	90.9	84.5	75.3	74.2	68.5	72.6
7	1	1530.0	76.5	104.7	96.0	96.4	92.7	90.3	86.0	69.5 *	76.7 *			
	2	1530.0	76.5	105.8	98.4	98.0	90.6	90.0	83.0	74.6 *	75.1 *	75.1 *	73.7 *	
	3	1530.0	76.5	103.0	95.2	95.6	90.4	81.8	86.9	71.7 *	78.3 *		68.2 *	
	Average				104.6	96.8	96.8	91.4	88.7	85.6	72.4	76.9	75.1	71.8
8	1	1530.0	76.5	102.2	103.5	94.1	86.6	92.2	88.0	77.5 *	75.6 *			
	2	1530.0	76.5	92.9	104.1	94.0	86.4	92.6	86.0	76.2 *	70.3 *	71.7 *	70.1 *	
	3	1530.0	76.5	93.7	105.0	96.1	86.3	87.9	82.5	74.2 *	74.2 *	72.0 *	69.5 *	
	Average				98.4	104.2	94.8	86.4	91.4	86.0	76.2	73.9	71.9	69.8
13	1	1527.5	76.4	98.8	85.7	85.7	83.2	86.9	96.0	79.1	74.1	78.9	71.1	
	2	1537.5	76.9	103.2	100.9	89.8	86.1	89.9	96.6	85.1	82.2	75.1	73.2	
	3	1525.0	76.3	97.0	96.2	83.9	83.0	83.6	93.2	80.2	78.9	75.0	70.1 *	
	Average				100.5	97.5	87.2	84.3	87.5	95.5	82.3	79.5	76.7	71.7
14	1	1527.5	76.4	97.1	97.9	90.4	86.4	88.6	95.0	85.0	74.9	78.5	70.4	
	2	1537.5	76.9	101.2	84.7	92.9	86.5	92.0	97.8	86.2	83.7	77.2	76.1	
	3	1527.5	76.4	96.2	95.6	88.1	88.7	85.2	92.6	82.4	80.2	73.9	73.7	
	Average				98.7	95.3	90.9	87.3	89.4	95.6	84.8	80.9	76.9	74.0
15	1	1527.5	76.4	104.1	100.4	79.3	84.2	88.7	98.3	81.3	72.7	73.7	72.3	
	2	1537.5	76.9	93.7	99.2	91.2	85.8	92.5	95.2	80.2	85.3	78.0	72.1	
	3	1527.5	76.4	103.4	99.0	89.3	86.9	82.9	93.1	86.0	80.0	72.2 *	74.1	
	Average				102.2	99.6	88.8	85.8	89.6	96.1	83.3	81.8	75.4	72.9
16	1	1527.5	76.4	95.5	95.3	85.2	86.4	88.8	96.0	86.2	75.6	80.5	72.2	
	2	1540.0	77.0	104.2	101.3	92.4	85.6	90.5	97.2	86.0	84.4	78.0	75.0	
	3	1527.5	76.4	98.7	93.1	87.7	85.6	83.0	93.0	83.0	77.1	71.4 *	75.0	
	Average				100.9	98.0	89.5	85.9	88.4	95.7	85.3	80.8	78.0	74.3

* adjusted for Broadband Contributions

NA Not Available

TABLE B.10

CABIN MICROPHONE NUMBER 4 : PORT ENGINE COMPONENTS

Test Condition	Flight Number	RPM	BPF Hz	Harmonic Level, dB re 20 micro Pa										
				1	2	3	4	5	6	7	8	9	10	
1	1	1580.0	79.0	108.5	89.7	83.1	78.8	76.2			70.2 *			
	2	1572.5	78.6	107.4	90.2	83.2	88.1	81.0			78.9	72.6 *	69.9 *	
	3	1570.0	78.5	108.8	86.0	82.8	78.1	81.6	73.1 *	72.3 *				
	Average			108.3	89.0	83.0	84.2	80.2	73.1	75.4	72.6	69.9	NA	
2	1	1525.0	76.3	102.4	94.2	87.5		78.5	71.0 *	75.4 *				
	2	1525.0	76.3	100.4	95.8	87.5	79.2	76.1		69.4 *				
	3	1525.0	76.3	103.5	92.5	80.4	79.5	74.1		75.8 *				
	Average			102.3	94.4	86.1	79.4	76.6	71.0	74.3	NA	NA	NA	
3	1	1527.5	76.4	95.1	100.8	82.4	83.9	81.6	70.6 *	74.2 *	77.0 *			
	2	1527.5	76.4	97.3	102.3	84.1	79.4	78.0	70.2 *	78.3 *				
	3	1522.5	76.1	98.1	101.2	80.9	83.1	80.2						
	Average			97.0	101.5	82.7	82.5	80.2	70.4	76.7	77.0	NA	NA	
4	1	1572.5	78.6	106.4	102.5	79.8	85.2	83.2						
	2	1572.5	78.6	106.2	101.4	80.5	87.8	80.3	74.3 *					
	3	1572.5	78.6	107.7	101.7	78.2	89.9	82.8	76.9 *					
	Average			106.8	101.9	79.6	88.0	82.3	75.8	NA	NA	NA	NA	
9	1	1572.5	78.6	106.5	100.7	87.3	91.3	82.1	78.5 *	72.5 *	68.5 *	71.4 *	68.3 *	
	2	1575.0	78.8	104.6	100.8	86.6	91.6	86.5	71.7 *	73.9 *		68.0 *	69.5 *	
	3	1572.5	78.6	106.4	100.2	87.1	91.1	85.0	81.3	71.0 *				
	Average			105.9	100.6	87.0	91.3	84.9	78.7	72.6	68.5	70.0	68.9	
10	1	1525.0	76.3	96.5	100.1	89.2	73.3	83.3	70.9 *	74.2 *	73.6 *			
	2	1525.0	76.3	96.3	100.1	87.3	81.1	84.8	75.4 *	74.2 *				
	3	1525.0	76.3	96.4	98.0	86.9	79.5	85.6	68.2 *	69.8 *	74.5 *			
	Average			96.4	99.5	87.9	79.0	84.7	72.5	73.2	74.1	NA	NA	
12	1	1520.0	76.0	88.4	98.5	83.7	74.1	74.1	74.1 *		64.5 *	67.6 *		
	2	1520.0	76.0	85.2	99.5	77.9	80.0	79.4	66.3 *	72.0 *	64.0 *	62.0 *	71.6 *	
	3	1520.0	76.0	85.9	97.9	79.1	78.2	83.1	70.7 *	72.2 *	65.8 *	61.0 *	68.2 *	
	Average			86.7	98.7	81.0	78.1	80.2	71.4	72.1	64.8	64.6	70.2	
17	1	1572.5	78.6	101.2	93.2	81.4	78.1	74.5	83.0	69.9 *	75.1 *	68.4 *	69.5 *	
	2	1570.0	78.5	100.9	94.4	78.4	75.4	79.8	82.1	70.2 *	70.8 *	70.5 *	66.5 *	
	3	1570.0	78.5	100.1	90.1	81.4	79.8	68.9	76.1	72.4	71.2 *	61.7 *	66.2 *	
	Average			100.8	92.9	80.6	78.1	76.4	81.3	71.0	72.8	68.2	67.7	
18	1	1522.5	76.1	96.5	90.7	79.1	67.2	68.1	80.6	71.5 *	68.8 *		72.8 *	
	2	1522.5	76.1	96.7	93.6	80.2	63.9	72.0	80.7	75.3	69.7 *		63.2 *	
	3	1522.5	76.1	96.3	90.7	74.0	65.8	67.0	79.2	72.1 *			65.9 *	
	Average			96.5	91.9	78.5	65.8	69.6	80.2	73.3	69.3	NA	69.2	

* adjusted for Broadband Contributions

NA Not Available

TABLE B.11

CABIN MICROPHONE NUMBER 4 : STARBOARD ENGINE COMPONENTS

Test Condition	Flight Number	RPM	BPF Hz	Harmonic Level, dB re 20 micro Pa										
				1	2	3	4	5	6	7	8	9	10	
1	1	1525.0	76.3	100.9	91.4	84.4	78.6	75.6			70.8 *			
	2	1520.0	76.0	100.5	93.6	85.9	79.2	79.3	75.7 *					
	3	1520.0	76.0	100.0	94.0	81.5	78.9	78.0	69.3 *	70.4 *				
	Average			100.5	93.1	84.3	78.9	77.9	73.6	70.6	NA	NA	NA	
2	1	1570.0	78.5	101.8	91.6	82.7	75.1	78.0						
	2	1570.0	78.5	100.5	89.0	83.7	80.9	80.8						
	3	1572.5	78.6	99.1	91.3	78.4	73.8	78.1		68.0 *				
	Average			100.6	90.8	82.1	77.8	79.2	NA	68.0	NA	NA	NA	
3	1	1572.5	78.6	105.2	86.9	77.2	78.9	79.6	72.7 *		72.8 *			
	2	1570.0	78.5	105.3	88.0	72.9	77.6	81.1	73.2 *			70.3 *		
	3	1570.0	78.5	103.2	92.6	69.4	77.6	82.6				68.4 *		
	Average			104.7	89.9	74.3	78.1	81.3	73.0	NA	72.8	69.5	NA	
4	1	1517.5	75.9	104.4	89.1	67.6	78.9	82.0	74.1 *	72.1 *				
	2	1520.0	76.0	104.0	90.3	76.0	73.1	80.7		70.9 *				
	3	1520.0	76.0	103.5	90.4	76.4	79.3	82.4		73.2 *				
	Average			104.0	90.0	74.7	77.9	81.8	74.1	72.2	NA	NA	NA	
9	1	1520.0	76.0	106.0	91.3	79.6	82.6	78.2	72.2 *	76.1 *				
	2	1520.0	76.0	104.4	90.3	80.2	82.0	78.3	71.0 *	75.4 *				
	3	1520.0	76.0	104.3	89.7	77.1	86.0	81.0	79.3 *	75.5 *				
	Average			105.0	90.5	79.2	83.9	79.4	75.8	75.7	NA	NA	NA	
10	1	1572.5	78.6	108.0	80.1	76.6	72.0	78.9	82.5	71.7 *	70.3 *			
	2	1570.0	78.5	105.3	81.8	79.1	81.2	77.2	75.6 *	71.5 *	66.2 *			
	3	1572.5	78.6	106.7	88.1	74.3	82.5	78.1	79.2 *	71.4 *	67.2 *			
	Average			106.8	84.8	77.1	80.4	78.1	80.0	71.5	68.3	NA	NA	
11	1	1517.5	75.9	102.6	84.3	75.5	75.9	75.6	78.0		69.1 *	68.3 *	67.2 *	
	2	1515.0	75.8	102.9	86.7	74.6	77.8	78.8	78.2	69.4 *	66.2 *	68.4 *	66.7 *	
	3	1515.0	75.8	103.6	90.9	66.6	81.6	83.8	81.0	69.4 *	75.1 *	68.4 *	67.8 *	
	Average			103.1	88.2	73.6	79.1	80.7	79.3	69.4	71.7	68.4	67.3	
17	1	1517.5	75.9	101.0	86.4	76.6	75.6	79.2	83.1	82.0	63.1 *	69.5 *	69.1 *	
	2	1517.5	75.9	100.2	75.6	74.1	76.1	78.3	88.3	82.6	75.0	70.1 *		
	3	1517.5	75.9	99.2	80.5	79.7	77.7	76.7	86.3	83.1	77.0	69.0 *		
	Average			100.2	82.9	77.4	76.6	78.2	86.4	82.6	74.5	69.6	69.1	
18	1	1575.0	78.8	102.9	90.9	80.1	79.2	87.0	94.2	87.7	76.2	74.0	67.4 *	
	2	1572.5	78.6	101.9	88.6	76.2	84.0	90.2	93.0	88.5	65.1 *	75.7		
	3	1570.0	78.5	102.3	89.3	74.6	82.9	89.1	82.0	86.0	71.2 *	71.5 *	64.0 *	
	Average			102.4	89.7	77.6	82.5	89.0	92.0	87.5	72.9	74.1	66.0	

* adjusted for Broadband Contributions

NA Not Available

TABLE B.12

CABIN MICROPHONE NUMBER 4 : PORT & STARBOARD ENGINE COMPONENTS

Test Condition	Flight Number	RPM	BPF Hz	Harmonic Level, dB re 20 micro Pa										
				1	2	3	4	5	6	7	8	9	10	
5	1	1532.5	76.6	106.3	102.1	87.3	82.1	84.7	79.2 *	73.3 *	71.1 *			
	2	1530.0	76.5	102.8	101.9	87.5	80.6	85.3	74.5 *	74.0 *	78.5 *			
	3	1530.0	76.5	104.8	101.8	85.0	85.5	87.2	82.9	74.3 *	76.2 *	70.1 *	69.5 *	
	Average			104.9	101.9	86.7	83.2	85.9	80.1	73.9	76.2	70.1	69.5	
6	1	1530.0	76.5	103.6	96.2	85.5	75.9	84.0	72.3 *				72.9 *	
	2	1530.0	76.5	100.0	96.1	84.2	78.3	86.3	81.2	75.3 *	74.1 *	69.5 *		
	3	1532.5	76.6	100.7	95.0	84.6	87.1	81.0	78.2 *	72.6 *	74.9 *	68.0 *		
	Average			101.7	95.8	84.8	83.1	84.3	78.6	74.2	74.5	68.8	72.9	
7	1	1530.0	76.5	109.1	100.4	86.4	87.1	85.3	72.3 *	72.8 *	70.6 *		72.4 *	
	2	1530.0	76.5	107.6	100.4	87.0	82.3	86.5	81.5	78.4 *	74.7 *	67.5 *		
	3	1530.0	76.5	108.2	97.6	86.2	89.6	87.5	79.1 *		75.5 *		74.0 *	
	Average			108.3	99.7	86.5	87.3	86.5	79.0	76.4	74.1	67.5	73.3	
8	1	1530.0	76.5	105.8	102.4	86.2	84.8	84.2	76.6 *	75.9 *	77.7 *		70.6 *	
	2	1532.5	76.6	106.1	101.8	84.6	87.4	84.2	78.2 *	76.9 *	76.3 *			
	3	1530.0	76.5	106.8	102.6	86.7	89.5	87.5	80.3	78.0 *	80.6 *		70.5 *	
	Average			106.3	102.3	85.9	87.6	85.6	78.6	77.0	78.6	NA	70.6	
13	1	1527.5	76.4	101.9	78.8	81.4	82.9	80.1	89.2	82.4	80.1	77.2	72.9	
	2	1537.5	76.9	103.3	94.1	78.1	82.9	81.3	92.7	86.0	79.5	77.4	67.9 *	
	3	1525.0	76.3	99.9	90.8	74.1	80.8	80.9	88.4	86.2	77.0	76.3	65.1 *	
	Average			101.9	91.1	78.8	82.3	80.8	90.5	85.2	79.1	77.0	69.8	
14	1	1527.5	76.4	93.6	93.5	83.2	76.2	81.9	88.1	85.0	75.0	78.3	75.2	
	2	1537.5	76.9	104.6	90.0	83.0	83.5	85.7	93.3	86.4	78.3	80.0	73.2	
	3	1527.5	76.4	88.2	89.1	82.7	79.5	85.4	84.8	86.2	75.6	77.0	72.3	
	Average			100.3	91.3	83.0	80.7	84.6	90.1	85.9	76.5	78.6	73.7	
15	1	1527.5	76.4	105.3	94.4	74.5	72.1	79.3	92.2	85.0	78.1	74.4	76.2	
	2	1537.5	76.9	90.9	91.5	83.3	79.0	87.2	88.3	85.7	78.2	78.9	74.6	
	3	1527.5	76.4	102.9	93.5	82.0	80.8	83.2	84.1	86.9	75.3	76.1	71.3	
	Average			102.6	93.3	81.3	78.6	84.4	89.4	85.9	77.4	76.9	74.5	
16	1	1527.5	76.4	101.8	91.6	79.1	79.3	80.6	89.0	84.0	75.2	77.3	74.6 *	
	2	1540.0	77.0	103.7	96.4	84.0	84.2	84.7	91.9	86.4	75.4	80.0	74.3	
	3	1527.5	76.4	102.2	90.5	79.9	81.7	81.7	84.8	84.1	76.1	77.3	72.1	
	Average			102.6	93.6	81.6	82.2	82.7	89.5	85.0	75.6	78.4	73.8	

* adjusted for Broadband Contributions

NA Not Available

TABLE B.13

CABIN MICROPHONE NUMBER 5 : PORT ENGINE COMPONENTS

Test Condition	Flight Number	RPM	BPF Hz	Harmonic Level, dB re 20 micro Pa										
				1	2	3	4	5	6	7	8	9	10	
1	1	1580.0	79.0	99.5	104.7	93.8	81.4	73.7 *	69.0 *	70.9 *				
	2	1572.5	78.6	98.3	103.6	94.8	85.9	78.4	78.9	69.2 *		71.7 *	64.3 *	
	3	1572.5	78.6	100.0	103.5	94.1	80.1	75.4	74.7 *	69.4 *	67.2 *	70.6 *		
	Average			99.3	104.0	94.3	83.2	76.3	75.8	69.9	67.2	71.2	64.3	
2	1	1525.0	76.3	92.6	104.8	97.7	81.3	77.1 *	75.8 *					
	2	1525.0	76.3	90.6	103.4	95.6	80.9	70.5 *	70.9 *	66.1 *				
	3	1525.0	76.3	93.1	103.2	92.7	80.1	72.6 *	75.9 *	66.9 *				
	Average			92.2	103.9	95.8	80.8	74.3	74.7	66.5	NA	NA	NA	
3	1	1527.5	76.4	86.2	102.2	95.2	76.4	83.8	86.8	71.6 *				
	2	1525.0	76.3	80.0	103.7	93.3	74.6	85.6	82.0	82.1	73.0 *			
	3	1525.0	76.3	90.0	104.0	92.7	77.8	86.4	80.5	81.9				
	Average			87.0	103.4	93.9	76.5	85.4	84.0	80.4	73.0	NA	NA	
4	1	1572.5	78.6	98.8	106.8	92.8	88.6	90.8	89.4	78.9 *	76.6 *	72.5 *		
	2	1572.5	78.6	98.1	104.4	89.6	85.3	81.8	87.9	81.5	72.7 *	74.7 *		
	3	1572.5	78.6	101.2	105.4	87.4	86.9	84.8	88.7	82.2 *	77.7 *	77.3 *	73.6 *	
	Average			99.6	105.6	90.5	87.1	87.4	88.7	81.1	76.1	75.3	73.6	
9	1	1572.5	78.6	98.2	105.9	93.6	89.1	91.6	91.0	84.1				
	2	1575.0	78.8	93.0	105.8	90.7	88.6	90.4	86.0	80.1		72.1 *	70.7 *	
	3	1572.5	78.6	97.1	105.2	88.1	91.4	91.4	90.2	80.2 *		67.3 *	74.1 *	
	Average			96.6	105.6	91.4	89.9	91.2	89.5	81.9	NA	70.3	72.7	
10	1	1525.0	76.3	86.3	103.7	94.8	83.2	83.2	85.2	76.3 *	74.1 *			
	2	1525.0	76.3	88.8	105.2	93.0	82.5	80.3	87.9	74.7 *	75.7 *			
	3	1525.0	76.3	84.3	104.4	91.0	82.4	83.7	77.8 *	75.5 *	73.0 *			
	Average			86.9	104.5	93.2	82.7	82.6	85.3	75.5	74.4	NA	NA	
12	1	1520.0	76.0	80.3	103.0	87.3	72.9	81.3	81.1	72.9 *	73.7 *	68.7 *		
	2	1520.0	76.0	77.8	102.3	85.2	68.3	80.6	84.2	75.0	70.6 *			
	3	1520.0	76.0	88.4	103.4	84.3	64.3 *	83.6	82.1	77.1	72.3 *			
	Average			84.6	102.9	85.8	69.8	82.0	82.7	75.3	72.4	68.7	NA	
17	1	1572.5	78.6	89.9	102.7	79.3	81.6	86.3	93.0	81.1	66.6 *	80.4	69.5 *	
	2	1570.0	78.5	90.1	102.8	82.3	78.4	86.9	89.1	77.0	69.8 *	80.1	67.1 *	
	3	1570.0	78.5	87.3	101.1	82.3	81.0	84.4	91.0	73.2	68.0 *	76.5		
	Average			89.3	102.3	81.5	80.5	86.0	91.3	78.2	68.3	79.3	68.5	
18	1	1522.5	76.1	90.1	99.2	82.1	69.4	85.6	88.5	79.7	66.3 *			
	2	1522.5	76.1	87.5	98.4	81.9	76.2	86.0	87.2	81.8	75.0		62.4 *	
	3	1520.0	76.0	88.9	93.5	87.9	73.6	84.1	88.6	76.0	67.9 *			
	Average			89.0	97.7	84.9	73.9	85.3	88.1	79.8	71.5	NA	62.4	

* adjusted for Broadband Contributions

NA Not Available

TABLE B.14

CABIN MICROPHONE NUMBER 5 : STARBOARD ENGINE COMPONENTS

Test Condition	Flight Number	RPM	BPF Hz	Harmonic Level, dB re 20 micro Pa										
				1	2	3	4	5	6	7	8	9	10	
1	1	1525.0	76.3	94.5	97.5	81.9	72.0 *	72.5 *						
	2	1520.0	76.0	91.8	100.5	90.3	74.0 *	69.7 *	69.4 *	68.1 *				64.2 *
	3	1520.0	76.0	95.5	98.9	81.4 *	68.4 *	72.6 *	72.7 *					
	Average			94.2	99.1	86.6	72.0	71.8	71.4	68.1	NA	NA		64.2
2	1	1570.0	78.5	99.6	99.7	84.8	79.4	80.7	80.2	71.0 *				
	2	1570.0	78.5	98.0	99.1	82.9	81.4	83.2	78.1	69.3 *			67.4 *	
	3	1572.5	78.6	99.1	98.7	82.2	82.2	78.5	73.7 *					
	Average			99.0	99.2	83.4	81.2	81.2	78.1	70.2	NA	67.4		NA
3	1	1572.5	78.6	95.4	101.2	89.3	86.1	79.3	84.0	72.0 *				
	2	1570.0	78.5	94.8	102.8	91.0	87.4	80.1	72.6 *	71.1 *				
	3	1570.0	78.5	95.1	103.0	90.0	86.1	74.9 *	71.6 *	73.4 *				
	Average			95.1	102.4	90.2	86.6	78.6	79.8	72.3	NA	NA		NA
4	1	1517.5	75.9	93.1	100.2	86.4	82.2	82.4						
	2	1520.0	76.0	93.8	102.1	89.0	79.4	85.4	71.3 *					
	3	1517.5	75.9	92.1	100.2	89.1	79.4	83.1						
	Average			93.1	100.9	88.3	80.5	83.8	71.3	NA	NA	NA		NA
9	1	1520.0	76.0	89.5	101.6	88.0	83.2	82.6	75.5 *					
	2	1520.0	76.0	91.1	101.6	88.4	83.6	85.8	78.5 *					
	3	1520.0	76.0	89.4	100.4	88.5	83.3	77.5	75.3 *					
	Average			90.1	101.2	88.3	83.4	83.1	76.7	NA	NA	NA		NA
10	1	1572.5	78.6	94.9	103.4	86.7	86.3	91.3		77.9 *			70.7 *	
	2	1570.0	78.5	90.8	102.9	89.9	88.5	89.2		72.8 *			70.1 *	
	3	1572.5	78.6	94.9	104.4	88.5	88.6	85.9		74.1 *	72.7 *			67.7 *
	Average			93.9	103.6	88.6	87.9	89.3	NA	75.5	72.7	70.4		67.7
11	1	1515.0	75.8	100.1	95.1	90.3	81.2	82.4	83.1		69.0 *	69.3 *	71.9	
	2	1517.5	75.9	98.3	98.7	89.8	81.4	83.7	82.0	65.7 *	68.1 *	59.6 *	64.0 *	
	3	1515.0	75.8	95.3	97.9	90.8	83.6	71.6	82.2	68.5 *	71.5 *		67.8 *	
	Average			98.3	97.5	90.3	82.2	81.5	82.5	67.3	69.8	66.7		69.0
17	1	1517.5	75.9	93.6	96.9	84.4	83.1	83.0	89.7	63.8 *	76.2	75.6 *	70.6 *	
	2	1517.5	75.9	93.0	93.7	86.6	83.1	84.2	88.5	75.0	73.9	71.3 *	66.8 *	
	3	1517.5	75.9	94.4	95.0	87.5	81.5	79.2	86.6	71.9 *	77.5 *	71.6 *	67.2 *	
	Average			93.7	95.4	86.4	82.6	82.6	88.4	72.2	76.1	73.3		68.6
18	1	1575.0	78.8	87.7	103.3	90.9	88.7	91.3	92.7	85.1	76.3	82.3	72.4 *	
	2	1572.5	78.6	89.8	101.3	90.7	85.4	92.6	86.2	84.0	73.9	81.0	75.2 *	
	3	1570.0	78.5	90.2	101.7	91.3	87.8	89.5	84.0	74.3		80.7	70.6 *	
	Average			89.4	102.2	91.0	87.5	91.3	89.3	83.0	75.3	81.4		73.2

* adjusted for Broadband Contributions

NA Not Available

TABLE B.15

CABIN MICROPHONE NUMBER 5 : PORT & STARBOARD ENGINE COMPONENTS

Test Condition	Flight Number	RPM	BPF Hz	Harmonic Level, dB re 20 micro Pa									
				1	2	3	4	5	6	7	8	9	10
5	1	1532.5	76.6	88.9	108.7	98.1	89.7	89.4	83.0	78.6 *	77.4 *		72.2 *
	2	1530.0	76.5	91.3	108.9	97.0	88.2	89.9	83.6	78.3 *	77.5 *	70.6 *	66.2 *
	3	1530.0	76.5	92.6	109.1	94.3	85.1	87.1	74.5 *	74.7 *	74.0 *		71.5 *
	Average			91.2	108.9	96.7	88.1	89.0	81.8	77.5	76.6	70.6	70.7
6	1	1530.0	76.5	84.8	92.4	94.9	87.0	89.4	88.9	75.4 *	76.4 *	71.2 *	
	2	1532.5	76.6	77.2	94.5	85.5	86.4	88.7	84.1	80.1	75.7 *		
	3	1532.5	76.6	83.9	97.1	90.6	89.9	87.8	77.3 *	73.4 *	76.8 *	67.8 *	
	Average			83.0	95.1	91.9	88.1	88.7	85.6	77.2	76.3	69.8	NA
7	1	1530.0	76.5	91.8	106.0	95.2	86.4	86.7	88.1		77.9 *		71.4 *
	2	1530.0	76.5	93.4	107.4	87.6	87.6	80.4	81.2 *	78.1 *	77.4 *	75.3 *	
	3	1530.0	76.5	92.8	106.0	92.4	89.4	88.2	78.4 *	74.6 *	80.5 *		68.4 *
	Average			92.7	106.5	92.7	88.0	86.2	84.5	76.7	78.8	75.3	70.2
8	1	1530.0	76.5	95.3	109.1	95.3	81.8	84.4	87.4		78.3 *		69.5 *
	2	1532.5	76.6	92.6	109.1	91.4	80.4	85.2	86.0	77.1 *	75.2 *		
	3	1530.0	76.5	88.1	108.1	87.5	82.3	88.8	84.1	69.0 *	76.7 *		68.0 *
	Average			92.9	108.8	92.5	81.6	86.6	86.0	74.7	76.9	NA	68.8
13	1	1527.5	76.4	99.4	90.1	89.7	82.4	89.0	88.4	83.0	76.9	81.0	69.7 *
	2	1537.5	76.9	89.4	103.5	89.9	85.6	91.8	89.2	81.1	77.0	77.9	73.2
	3	1525.0	76.3	98.5	92.9	92.9	81.0	88.0	89.2	76.1	75.9	79.9	69.2 *
	Average			97.4	99.3	91.1	83.4	89.9	88.9	80.9	76.6	79.8	71.1
14	1	1527.5	76.4	97.9	104.7	86.8	85.2	87.0	91.2	80.1	79.9	82.9	70.3 *
	2	1537.5	76.9	94.6	97.1	87.4	85.6	85.9	92.3	81.2	74.7	79.3	74.8
	3	1527.5	76.4	98.5	104.2	86.8	82.1	84.2	90.1	78.3	72.3 *	78.5	71.8 *
	Average			97.3	103.1	87.0	84.6	85.8	91.3	80.0	76.8	80.7	72.7
15	1	1527.5	76.4	89.1	105.0	90.6	83.4	83.0	96.8	81.9	73.8 *	79.3 *	71.4 *
	2	1537.5	76.9	97.3	104.7	87.4	83.8	87.4	87.1	82.5	74.4	78.3	78.4
	3	1527.5	76.4	90.5	102.0	87.5	85.6	89.8	90.6	81.1	76.1	78.5	72.0 *
	Average			93.9	104.1	88.8	84.4	87.5	93.3	81.9	74.9	78.7	75.2
16	1	1527.5	76.4	98.3	98.7	89.0	84.5	89.6	93.1	82.5	79.7	81.9	71.1 *
	2	1540.0	77.0	88.0	102.7	87.0	86.3	93.9	92.9	81.2	74.5	79.8	76.2
	3	1527.5	76.4	97.5	90.8	90.3	80.8	87.0	90.2	78.0	76.9	79.1	71.1 *
	Average			96.4	99.6	89.0	84.4	91.1	92.3	80.9	77.5	80.4	73.5

* adjusted for Broadband Contributions

NA Not Available

TABLE B.16

CABIN MICROPHONE NUMBER 6 : PORT ENGINE COMPONENTS

Test Condition	Flight Number	RPM	BPF Hz	Harmonic Level, dB re 20 micro Pa										
				1	2	3	4	5	6	7	8	9	10	
1	1	1580.0	79.0	109.0	97.8	86.0	79.1	81.5		70.7 *				
	2	1572.5	78.6	107.7	99.5	84.1	78.2	84.0	72.4 *	71.4 *		69.7 *		
	3	1572.5	78.6	108.3	97.6	87.6	82.2	83.7	68.7 *	71.5 *				
	Average			108.4	98.4	86.1	80.2	83.2	70.9	71.2	NA	69.7	NA	
2	1	1525.0	76.3	104.0	95.4	89.3	85.2	79.0 *	70.0 *	73.2 *				
	2	1525.0	76.3	102.5	96.2	88.9	77.3 *		73.5 *					
	3	1525.0	76.3	103.6	93.9	83.4	83.4	74.2 *	71.9 *	72.8 *				
	Average			103.4	95.3	87.9	83.0	77.2	72.0	73.0	NA	NA	NA	
3	1	1527.5	76.4	103.1	95.4	75.0	85.0	84.3	81.3 *		72.3 *			
	2	1525.0	76.3	104.2	95.0	73.9	81.2	82.7	74.5 *	77.1 *	73.2 *			
	3	1525.0	76.3	104.3	92.2	79.1	75.0 *	81.7	76.1 *	75.9 *	70.9 *			
	Average			103.9	94.4	76.6	82.0	83.0	78.3	76.5	72.2	NA	NA	
4	1	1572.5	78.6	109.4	99.4	84.8	87.4	93.8	81.4 *	79.9 *	77.5 *			
	2	1572.5	78.6	109.2	99.5	81.1	86.9	87.9	83.1					
	3	1572.5	78.6	110.5	97.8	85.6	88.9	90.5	81.0 *	74.7 *	71.4 *			
	Average			109.7	99.0	84.2	87.8	91.4	81.9	78.0	75.4	NA	NA	
9	1	1572.5	78.6	109.8	97.2	82.8	88.4	91.8	75.7 *	75.9 *				
	2	1575.0	78.8	107.8	98.9	85.4	84.8	91.2		69.8 *	70.6 *			
	3	1572.5	78.6	109.4	100.6	86.9	87.9	90.2	78.5 *	75.8 *	73.6 *	71.0 *		
	Average			109.1	99.1	85.3	87.3	91.1	77.3	74.6	72.4	71.0	NA	
10	1	1525.0	76.3	103.0	94.7	73.6	85.9	83.9	76.0 *		76.6 *		69.9 *	
	2	1525.0	76.3	102.0	95.4	84.8	86.9	82.0	78.5 *	74.8 *				
	3	1525.0	76.3	102.2	95.5	80.1	86.5	84.4	72.4 *	74.5 *				
	Average			102.4	95.2	81.5	86.5	83.5	76.3	74.7	76.6	NA	69.9	
12	1	1520.0	76.0	100.0	82.8	72.0	85.1	87.5	84.0	78.0	76.0 *		64.1 *	
	2	1520.0	76.0	98.2	87.9	79.0	86.2	84.4	73.1 *	70.2 *	77.4 *			
	3	1520.0	76.0	98.8	86.0	80.1	85.3	83.7	76.6 *	68.0 *	70.3 *	66.1 *	61.5 *	
	Average			99.1	86.0	78.2	85.6	85.5	80.2	74.3	75.5	66.1	63.0	
17	1	1572.5	78.6	103.1	93.1	80.0	84.2	82.4	85.7	74.0 *	78.3	73.5 *	65.9 *	
	2	1570.0	78.5	102.3	94.8	83.8	85.8	76.5	85.3	73.8 *	75.4 *	67.8 *	67.5 *	
	3	1570.0	78.5	101.7	92.6	82.6	82.4	83.2	81.6	77.0	71.8 *	72.7 *		
	Average			102.4	93.6	82.4	84.4	81.5	84.5	75.2	75.9	72.0	66.8	
18	1	1522.5	76.1	96.8	91.0	72.1 *	83.9	70.2 *	89.9	74.8 *	72.6 *		64.4 *	
	2	1522.5	76.1	97.3	91.1	76.2	85.9	73.7	88.6	79.1	74.6 *		63.3 *	
	3	1520.0	76.0	96.5	91.9	82.5	80.4	78.8	85.0	77.2	68.6 *			
	Average			96.9	91.4	79.0	83.9	75.6	88.3	77.4	72.6	NA	63.9	

* adjusted for Broadband Contributions

NA Not Available

TABLE B.17

CABIN MICROPHONE NUMBER 6 : STARBOARD ENGINE COMPONENTS

Test Condition	Flight Number	RPM	BPF Hz	Harmonic Level, dB re 20 micro Pa										
				1	2	3	4	5	6	7	8	9	10	
1	1	1525.0	76.3	100.5	89.1	86.5	82.3	76.1 *						
	2	1520.0	76.0	99.8	91.8	70.7 *	81.0	72.3 *	67.4 *					
	3	1520.0	76.0	100.3	88.3	85.7	79.5	75.2 *		68.7 *				
	Average			100.2	90.0	84.4	81.1	74.8	67.4	68.7	NA	NA	NA	
2	1	1570.0	78.5	103.9	95.3	90.2	78.8 *	80.9 *	71.0 *					
	2	1570.0	78.5	102.6	93.3	87.3	78.4	73.1 *						
	3	1572.5	78.6	102.3	96.0	88.1	70.0 *	78.5 *						
	Average			103.0	95.0	88.7	77.1	78.5	71.0	NA	NA	NA	NA	
3	1	1572.5	78.6	103.8	92.4	80.2	74.4 *	76.1 *	73.9 *					
	2	1570.0	78.5	104.4	94.7	74.5	76.9 *	78.8 *	79.0 *					
	3	1570.0	78.5	101.5	99.4	76.0	80.7	75.3 *	78.0 *					
	Average			103.4	96.5	77.6	78.1	77.0	77.5	NA	NA	NA	NA	
4	1	1517.5	75.9	101.2	96.8	73.5	72.2 *	80.0 *	75.5 *					72.6 *
	2	1520.0	76.0	101.3	96.5	77.3	75.0 *	81.2						
	3	1517.5	75.9	100.5	95.1	78.8	76.2 *	83.0	73.8 *	72.9 *				
	Average			101.0	96.2	77.0	74.8	81.6	74.7	72.9	NA	NA	72.6	
9	1	1520.0	76.0	103.6	98.9	79.9	83.3							
	2	1520.0	76.0	101.8	97.8	78.5	83.5							
	3	1520.0	76.0	101.2	95.0	79.2	79.0	72.2 *						
	Average			102.3	97.5	79.2	82.4	72.2	NA	NA	NA	NA	NA	
10	1	1572.5	78.6	106.6	94.2	77.6	85.1	78.5 *	75.6 *					
	2	1570.0	78.5	103.6	88.1	79.5	77.6	69.7 *	79.8 *					
	3	1572.5	78.6	105.2	92.4	80.4	82.1	72.5 *	80.2 *	75.7 *	74.9 *			
	Average			105.3	92.2	79.3	82.6	75.1	79.0	75.7	74.9	NA	NA	
11	1	1515.0	75.8	95.9	99.2	77.7	82.9	84.5	65.2 *	69.1 *	68.1 *	68.0 *	72.9 *	
	2	1515.0	75.8	98.6	98.2	75.7	80.1	86.3	71.3 *	70.6 *	72.0 *	65.9 *	67.6 *	
	3	1515.0	75.8	99.4	96.7	78.9	82.6	73.3 *	68.2 *	71.7 *	67.4 *	69.5 *	67.2 *	
	Average			98.2	98.2	77.6	82.0	83.9	68.9	70.6	69.7	68.0	70.1	
17	1	1517.5	75.9	95.9	93.7	81.8	66.2 *	74.8	88.4	77.2	77.0	75.8 *	68.6 *	
	2	1517.5	75.9	95.6	93.3	84.1	72.6 *	71.1 *	84.9	78.8	72.9 *	76.5 *	67.3 *	
	3	1517.5	75.9	93.4	94.2	83.9	67.6	75.3	80.7	78.5	78.6	71.5 *	68.2 *	
	Average			95.1	93.7	83.4	69.7	74.1	85.7	78.2	76.8	75.1	68.1	
18	1	1575.0	78.8	99.8	94.6	87.2	74.8	84.1	87.6	75.5 *	79.0	70.1 *	64.2 *	
	2	1572.5	78.6	98.7	89.6	87.9	75.9	81.4	86.1	79.9	77.3	76.1	65.3 *	
	3	1570.0	78.5	98.7	93.2	89.0	79.9	82.2	79.3	79.2	73.0 *	70.7 *	67.6 *	
	Average			99.1	92.9	88.1	77.5	82.7	85.5	78.6	77.1	73.2	65.9	

* adjusted for Broadband Contributions

NA Not Available

TABLE B.18

CABIN MICROPHONE NUMBER 6 : PORT & STARBOARD ENGINE COMPONENTS

Test Condition	Flight Number	RPM	BPF Hz	Harmonic Level, dB re 20 micro Pa									
				1	2	3	4	5	6	7	8	9	10
5	1	1532.5	76.6	104.9	99.7	82.3	86.9	85.6	78.3 *	71.6 *	76.0 *	74.5 *	70.4 *
	2	1530.0	76.5	102.8	99.8	80.6	85.7	85.9	84.1	73.0 *		74.5 *	70.4 *
	3	1530.0	76.5	104.6	101.5	68.4 *	86.3	82.6	79.9 *	78.0 *	76.2 *		
	Average			104.2	100.4	79.9	86.3	84.9	81.5	75.1	76.1	74.5	70.4
6	1	1530.0	76.5	92.9	94.5	78.1	88.1	87.0	76.5 *	73.0 *	73.7 *	76.5 *	71.5 *
	2	1532.5	76.6	91.9	93.2	84.5	87.5	82.8	75.9 *	82.1	72.7 *	70.0 *	
	3	1532.5	76.6	96.0	88.7	81.1	86.7	86.5	73.3 *	77.1 *	74.1 *	75.0 *	
	Average			94.0	92.7	82.0	87.5	85.8	75.4	78.9	73.5	74.6	71.5
7	1	1530.0	76.5	109.7	95.9	76.2	82.0	84.8		72.5 *	75.2 *	73.2 *	
	2	1530.0	76.5	108.1	98.2	83.8	79.8	86.5	76.5 *	76.0 *	74.4 *	73.4 *	73.9 *
	3	1530.0	76.5	108.9	99.4	75.3	86.1	82.7	79.8 *	74.5 *	79.8 *		
	Average			108.9	98.1	80.2	83.4	84.9	78.5	74.6	77.2	73.3	73.9
8	1	1530.0	76.5	105.7	102.2	77.3	87.7	85.9	75.0 *		75.7 *	73.1 *	
	2	1530.0	76.5	106.1	101.4	78.8	88.4	80.9	81.2 *	72.1 *	76.3 *	74.5 *	
	3	1530.0	76.5	107.5	102.2	82.3	87.2	86.9	80.0 *	77.8 *		72.3 *	
	Average			106.5	101.9	80.0	87.8	85.2	79.4	75.8	76.0	73.4	NA
13	1	1527.5	76.4	100.2	86.8	80.0	88.3	79.3	89.3	78.0	79.1	74.5 *	72.3 *
	2	1537.5	76.9	100.4	97.6	78.5	87.8	78.7	86.2	79.0	82.1	77.3	70.2 *
	3	1525.0	76.3	98.0	86.7	83.9	83.2	81.8	86.0	77.1	82.2	72.1 *	70.1 *
	Average			99.7	93.5	81.4	87.0	80.2	87.4	78.1	81.4	75.1	71.0
14	1	1527.5	76.4	90.3	98.3	80.6	83.6	78.5	90.9	79.2	81.7	75.6 *	66.9 *
	2	1537.5	76.9	103.0	88.2	80.4	89.3	74.0	90.3	79.5	82.5	72.8 *	73.0 *
	3	1527.5	76.4	90.0	99.4	77.8	81.7	82.3	83.1	77.1	81.3	76.1	70.5 *
	Average			98.7	97.3	79.8	86.1	79.5	89.2	78.7	81.9	75.1	70.8
15	1	1527.5	76.4	102.7	97.8	83.2	83.2	75.1	92.9	82.0	71.5 *	77.2	73.4 *
	2	1537.5	76.9	93.0	99.3	76.9	81.9	80.2	83.7	76.1	82.2	78.7	74.2
	3	1527.5	76.4	99.3	97.8	76.6	84.3	81.9	84.3	81.0	82.2	77.1	69.7 *
	Average			99.9	98.4	80.1	83.2	79.9	89.1	80.3	80.6	77.7	72.8
16	1	1527.5	76.4	100.9	94.8	83.9	85.8	79.5	92.3	80.1	81.1	74.7 *	69.8 *
	2	1540.0	77.0	100.9	98.1	78.9	88.2	78.8	91.4	78.0	77.2	77.1	75.2
	3	1527.5	76.4	100.1	91.0	81.6	82.8	80.7	84.8	79.1	79.7	76.1	72.2 *
	Average			100.6	95.5	81.9	86.1	79.7	90.5	79.2	79.6	76.1	73.0

* adjusted for Broadband Contributions

NA Not Available

APPENDIX C

Interior Sound Pressure Levels at Harmonics of Propeller Blade
Passage Frequency: Flight 4, Interior Treated with Fiberglass.

TABLE C.1

CABIN MICROPHONE NUMBER 1 : FLIGHT #4

Test Condition	Flight Number	RPM	BPF Hz	Harmonic Level, dB re 20 micro Pa									
				1	2	3	4	5	6	7	8	9	10
STARBOARD ENGINE													
1	4	1520.0	76.0	101.8	94.0	89.2	69.2 *	66.2 *					
2		1570.0	78.5	102.1	97.5	84.0	75.2 *	69.4					
3		1572.5	78.6	104.7	98.2	81.2	73.2 *	73.1	72.2 *				
4		1517.5	75.9	105.3	94.1	78.4	71.0 *	60.3 *	73.2 *		69.7 *		
9		1530.0	76.5	105.7	91.4	78.1	72.1 *	65.0 *	73.4 *		67.5 *		
10		1572.5	78.6	105.0	93.2	79.8	74.8	72.8	69.7 *				
11		1515.0	75.8	103.1	92.4	71.7	74.2	67.4		60.0 *			
17		1517.5	75.9	100.7	85.3	85.8	64.3	68.1	71.4 *	61.1 *	59.0 *		
18		1572.5	78.6	101.2	92.1	83.3	78.8	66.5	79.9	60.3 *	59.3 *	64.3 *	
PORT ENGINE													
1	4	1575.0	78.8	103.1	101.9	80.9	76.8	59.5 *					
2		1525.0	76.3	105.5	99.1	84.8	69.8 *	58.9 *	72.1 *				
3		1527.5	76.4	109.4	100.4	85.1	73.6 *	64.1 *	70.3 *				
4		1572.5	78.6	108.3	100.5	88.2	74.0 *		67.9 *	71.3 *	64.5 *		
9		1575.0	78.8	108.1	101.9	87.8	75.2	73.8	75.5 *		67.1 *		
10		1527.5	76.4	110.7	97.5	87.6	71.6 *	70.4 *	74.5 *				
12		1520.0	76.0	109.2	93.0	77.2	65.8 *	58.4 *	66.2 *		57.6 *	60.6 *	
17		1570.0	78.5	104.6	94.5	81.2	77.5	67.3	78.0 *	63.7 *	56.1 *		
18		1522.5	76.1	105.2	89.0	82.1	71.6	64.8		61.6 *	62.7 *		
BOTH ENGINES													
13	4	1520.0	76.0	106.1	92.2	84.9	73.7	69.9	77.1	64.6 *	64.0 *	61.4 *	

* adjusted for Broadband Contributions

TABLE C.2

CABIN MICROPHONE NUMBER 2 : FLIGHT #4

Test Condition	Flight Number	RPM	BPF Hz	Harmonic Level, dB re 20 micro Pa												
				1	2	3	4	5	6	7	8	9	10			
STARBOARD ENGINE																
1	4	1520.0	76.0	106.0	93.2	80.2	78.5	62.8 *			56.2 *	52.3 *				
2		1570.0	78.5	103.3	92.5	79.6	76.5			56.8 *	59.0 *	51.7 *				
3		1572.5	78.6	106.7	96.0	73.8	72.6	73.6	65.8 *	62.6	57.2 *	52.1 *	51.3 *			
4		1517.5	75.9	109.4	91.9	76.6	71.7	75.7	64.3 *	59.6 *	55.4 *					
9		1530.0	76.5	109.6	91.9	79.7	71.2	74.6	67.2 *	58.6 *	59.7 *					
10		1572.5	78.6	107.5	95.6	77.5	70.7	75.3	69.5 *	58.5 *	63.6	54.4 *				
11		1515.0	75.8	108.7	92.7	79.2	71.2	72.4	60.9 *	61.3 *						
17		1517.5	75.9	103.9	93.4	81.8	72.1	65.9	70.0	67.8	54.5 *	59.0 *	53.2			
18		1572.5	78.6	102.1	95.2	73.9	77.6	70.7	75.4	63.8	56.4 *	57.0 *	55.2			
PORT ENGINE																
1	4	1575.0	78.8	105.1	103.0	81.2	71.0	68.9	68.6	59.0 *	52.7 *					
2		1525.0	76.3	108.7	101.4	79.7	69.1		67.1	53.5 *	53.5 *					
3		1527.5	76.4	112.0	94.1	79.5	69.2	76.2	73.1	63.3						
4		1572.5	78.6	109.4	99.4	82.2	67.8	77.9	71.3	65.2						
9		1575.0	78.8	109.1	97.0	79.2	61.0 *	79.0	76.2	69.0	51.0 *	58.9 *	54.9 *			
10		1527.5	76.4	112.7	94.6	86.6	68.7	75.7	77.6	65.3	53.0 *		53.8 *			
12		1520.0	76.0	111.0	96.0	86.0	66.7	61.2	72.5	62.0	55.3					
17		1570.0	78.5	105.9	97.3	83.3		71.0	76.3	71.1	61.1	63.0	60.9			
18		1522.5	76.1	107.2	94.5	81.8	66.4	68.8	73.7	67.8	62.3					
BOTH ENGINES																
13	4	1520.0	76.0	108.4	96.8	85.1	72.6	69.9	74.3	67.8	61.2	63.6	57.0			

* adjusted for Broadband Contributions

TABLE C.3

CABIN MICROPHONE NUMBER 3 : FLIGHT #4

Test Condition	Flight Number	RPM	BPF Hz	Harmonic Level, dB re 20 micro Pa									
				1	2	3	4	5	6	7	8	9	10
STARBOARD ENGINE													
1	4	1520.0	76.0	91.2	92.9	93.2	70.4	73.1	58.2 *	59.3 *	53.0 *		
2		1570.0	78.5	84.2	86.8	93.8	77.0	69.6		60.7 *	54.3 *	55.3 *	
3		1572.5	78.6	79.5	91.5	90.4	83.5	81.1	74.0	64.3 *	61.5 *	58.6 *	
4		1517.5	75.9	97.2	92.8	89.6	81.4	78.9	65.6 *	63.7 *	58.1 *		
9		1530.0	76.5	98.9	94.7	90.7	82.6	76.2	75.0	68.6	56.2 *		54.9 *
10		1572.5	78.6	91.4	87.6	90.4	81.7	78.9	75.0	68.1	63.4 *	62.1 *	
11		1515.0	75.8	97.6	93.7	88.5	81.9	72.9	73.1	61.2	60.1	56.3 *	52.7 *
17		1517.5	75.9	97.3	92.7	82.8	78.3	69.6	83.2	59.7 *	61.5	59.5 *	63.6
18		1572.5	78.6	89.9	90.4	80.3	79.8	74.8	87.6	67.5	73.1	70.1	64.4
PORT ENGINE													
1	4	1575.0	78.8	107.8	99.1	86.1	72.8	66.6	67.1	57.3 *		54.7 *	54.0 *
2		1525.0	76.3	106.5	93.9	84.4	69.1	69.7	66.9	55.6 *			51.2 *
3		1527.5	76.4	105.4	86.1	85.2	81.9	75.4	72.5				
4		1572.5	78.6	107.1	96.4	89.9	81.5	79.6	76.4	59.3 *	59.7 *	57.3 *	
9		1575.0	78.8	105.0	90.7	86.9	83.1	80.2	78.6	62.7 *	60.0 *	61.6 *	52.5 *
10		1527.5	76.4	102.9	91.5	88.2	83.8	69.9	71.9	61.1 *	58.0 *		
12		1520.0	76.0	104.3	94.8	83.9	79.0	72.3	70.0	62.7	58.2	52.5 *	48.5 *
17		1570.0	78.5	95.7	93.6	84.5	78.9	68.2	70.2	68.9	59.8	46.5 *	51.2 *
18		1522.5	76.1	92.0	93.4	83.3	76.3	75.7	72.9	68.0	53.5 *	58.1 *	50.0 *
BOTH ENGINES													
13	4	1520.0	76.0	98.4	96.7	85.3	80.4	76.4	84.3	67.1	63.7	63.2	62.1

* adjusted for Broadband Contributions

TABLE C.4

CABIN MICROPHONE NUMBER 4 : FLIGHT #4

Test Condition	Flight Number	RPM	BPF Hz	Harmonic Level, dB re 20 micro Pa																
				1	2	3	4	5	6	7	8	9	10							
STARBOARD ENGINE																				
1	4	1520.0	76.0	104.4	84.4	79.4	72.1	66.9	60.3 *	59.6 *	60.3 *									
2		1570.0	78.5	100.1	75.8	81.6	66.1	58.0 *	55.3 *											
3		1572.5	78.6	105.6	78.9	78.7	71.3	67.9												
4		1517.5	75.9	109.8	88.6	72.6	65.2	75.9	63.7 *	60.7 *	61.3 *									
9		1530.0	76.5	110.4	84.8	77.5	70.9	70.1	66.6 *	62.8 *	61.9 *									
10		1572.5	78.6	106.7	83.5	79.8	70.5	69.5	61.9 *	65.2 *	60.0 *	55.5 *								
11		1515.0	75.8	109.2	86.1	73.0	67.5	73.7	63.3 *	57.2 *	62.7	54.9 *	54.7 *							
17		1517.5	75.9	106.6	82.7	65.7	64.2	71.8	69.8	60.2 *									52.0 *	
18		1572.5	78.6	102.0	89.0	65.7	71.3	75.2	71.1	68.2	59.1 *	59.1 *	49.4 *							
PORT ENGINE																				
1	4	1575.0	78.8	111.3	93.0	81.3	77.7	68.1	62.6 *	53.4 *										
2		1525.0	76.3	111.6	94.3	78.2	72.9	58.4 *	59.6 *											
3		1527.5	76.4	112.6	100.2	78.1	80.1	60.0 *												
4		1572.5	78.6	113.0	99.6	80.4	81.9	65.6 *	68.4 *		57.3 *									
9		1575.0	78.8	111.1	99.9	75.4	81.5	57.8 *	68.3 *	60.1 *		57.0 *								
10		1527.5	76.4	111.7	98.9	76.9	78.9	71.8	69.2	66.9 *										
12		1520.0	76.0	111.2	96.8	57.5	71.5	72.0	64.1	61.6	61.7								49.6 *	
17		1570.0	78.5	104.4	93.6	76.7	70.1	70.4	64.1		55.1 *	51.0 *	53.5 *							
18		1522.5	76.1	104.0	92.0	75.6	70.2	68.8	64.2	57.5 *	54.7 *									
BOTH ENGINES																				
13	4	1520.0	76.0	107.8	92.4	75.1	68.7	73.2	72.6	61.2	58.1 *	61.4	52.6 *							

* adjusted for Broadband Contributions

TABLE C.5

CABIN MICROPHONE NUMBER 5 : FLIGHT #4

Test Condition	Flight Number	RPM	BPF Hz	Harmonic Level, dB re 20 micro Pa									
				1	2	3	4	5	6	7	8	9	10
STARBOARD ENGINE													
1	4	1520.0	76.0	107.4	89.8	77.6	63.4 *	57.2 *				57.5 *	
2		1570.0	78.5	106.0	90.6	78.5	59.8 *	59.0 *	58.0 *			60.3 *	
3		1572.5	78.6	108.8	91.8	69.6	64.2 *	59.0 *	64.8 *	59.6 *			
4		1517.5	75.9	110.8	93.5	74.9	68.0	72.2	59.3 *			58.3 *	
9		1530.0	76.5	111.3	95.5	76.7	57.0 *	73.8	67.4 *	60.7 *		59.4 *	
10		1572.5	78.6	109.0	89.7	78.9	66.5 *	73.1	68.5 *	62.5 *			
11		1515.0	75.8	109.5	96.3	79.2	73.2	67.3	65.3	62.2	62.5	54.2 *	
17		1517.5	75.9	106.6	95.4	79.9	61.5 *	67.4	55.1 *	64.1	56.9 *		
18		1572.5	78.6	103.9	94.6	80.0	70.4	71.5	70.6	65.1	65.5	56.1 *	57.4 *
PORT ENGINE													
1	4	1575.0	78.8	106.2	100.6	87.2	77.7	70.6	61.1 *			54.4 *	
2		1525.0	76.3	109.1	98.5	84.9	76.6		63.2 *			53.8 *	
3		1527.5	76.4	111.9	100.0	70.7	80.4	79.5	66.2 *	60.6 *	58.6 *		
4		1572.5	78.6	110.8	100.3	78.6	81.5	84.1		61.1 *	61.4 *	62.4 *	
9		1575.0	78.8	109.3	101.5	77.0	83.4	86.4	70.4 *		64.4 *	65.3	
10		1527.5	76.4	111.7	100.4	80.9	83.0	79.1	69.9		59.9 *	56.9 *	
12		1520.0	76.0	110.7	97.0	79.2	74.2	76.6	72.1	60.2	55.3 *	59.8	54.8 *
17		1570.0	78.5	104.1	93.7	78.6	82.6	77.8	72.2	63.1	63.1	57.2 *	50.3 *
18		1522.5	76.1	105.0	91.4	79.2	81.7	75.5	67.8	55.2 *	61.0 *		50.7 *
BOTH ENGINES													
13	4	1520.0	76.0	108.4	96.9	82.1	80.2	76.1	68.2	62.8	61.0	59.4	52.9

* adjusted for Broadband Contributions

TABLE C.6

CABIN MICROPHONE NUMBER 6 : FLIGHT #4

Test Condition	Flight Number	RPM	BPF Hz	Harmonic Level, dB re 20 micro Pa									
				1	2	3	4	5	6	7	8	9	10
STARBOARD ENGINE													
1	4	1520.0	76.0	98.5	96.4	76.5	69.8	60.1 *	61.2 *	56.8 *	53.3 *		
2		1570.0	78.5	100.1	96.2	82.4	72.9	57.0 *	66.2	56.2 *	53.5 *		
3		1572.5	78.6	100.5	101.2	81.7	75.2	75.5	68.6	64.0 *	55.8 *	58.6	52.2 *
4		1517.5	75.9	98.9	98.0	79.3	75.7	74.6	68.7	60.1 *	55.1 *		54.5 *
9		1530.0	76.5	98.9	100.5	78.1	79.2	77.2	73.4	64.4 *	61.5 *		
10		1572.5	78.6	98.6	101.2	80.4	79.5	81.2	74.2	67.7	59.9 *	56.9 *	
11		1515.0	75.8	96.1	97.9	81.9	74.5	70.2	72.0	52.9 *	60.6	58.2	52.5 *
17		1517.5	75.9	94.2	95.6	80.7	78.5	78.3	77.9	54.5 *	69.7		
18		1572.5	78.6	95.9	97.5	83.0	77.6	79.0	82.1	69.0	66.1	60.8	56.7
PORT ENGINE													
1	4	1575.0	78.8	97.4	106.1	97.5	88.7	66.9 *	71.2 *	57.8 *	51.2 *	62.0	
2		1525.0	76.3	97.4	105.2	97.0	86.0	66.2 *	72.6		52.8 *		51.8 *
3		1527.5	76.4	99.6	105.5	93.6	84.3	84.8	77.1	66.7	57.7 *		
4		1572.5	78.6	99.8	106.8	94.8	90.2	87.9	82.3	68.7	65.5	64.1	52.4 *
9		1575.0	78.8	97.7	107.4	91.5	89.1	87.9	84.1	69.1	65.6	66.0	53.9 *
10		1527.5	76.4	98.3	105.9	90.9	84.9	83.5	80.1	71.2	64.8 *		54.0 *
12		1520.0	76.0	99.4	104.2	87.1	84.0	80.1	78.9	65.2	55.7 *	50.3 *	51.1 *
17		1570.0	78.5	89.7	102.8	88.2	85.8	84.5	73.4	65.2	61.9	63.1	58.1
18		1522.5	76.1	90.3	101.2	88.3	80.5	81.4	75.5	70.1	53.0 *		57.4
BOTH ENGINES													
13	4	1520.0	76.0	97.6	102.1	89.1	81.6	82.1	80.5	69.2	66.2	63.0	59.4

* adjusted for Broadband Contributions

APPENDIX D

One-Third Octave Band Spectra for Exterior Fluctuating Pressures:
Flights 3 and 4.

TABLE D.1

ONE-THIRD OCTAVE BAND SOUND PRESSURE LEVELS, FLIGHT #3
EXTERIOR MICROPHONE, PORT SIDE.

Band Center Frequency Hz	One-Third Octave Band Sound Pressure Level, dB re 20 micro Pa								
	Test Condition								
	1	2	3	4	5	6	7	8	9
25	100.5	99.5	97.3	98.3	96.8	97.0	96.5	96.5	96.0
32	101.3	101.3	98.5	98.3	97.0	97.8	97.3	97.3	98.3
40	103.0	103.3	100.8	101.0	99.5	99.8	99.5	99.8	100.0
50	107.0	106.5	104.5	105.0	103.0	103.0	103.8	103.3	103.8
63	113.0	115.5	114.8	112.5	114.8	114.0	115.0	115.3	111.8
80	129.8	129.5	129.0	129.5	129.3	129.0	129.5	130.0	129.0
100	113.3	111.5	109.8	112.3	109.5	110.0	110.0	110.0	111.8
125	114.5	115.8	114.0	112.8	113.8	115.3	113.8	114.5	112.5
160	129.8	128.8	127.8	129.0	127.5	129.3	127.5	128.8	129.0
200	117.8	119.5	118.0	117.0	117.3	118.5	118.5	118.8	116.5
250	127.0	125.3	123.5	126.0	123.8	124.8	124.8	125.3	126.3
315	123.0	121.8	120.0	122.0	120.0	121.0	121.5	121.0	123.0
400	120.0	118.5	116.5	118.5	117.0	118.5	118.0	117.5	119.3
500	119.0	117.5	115.3	118.0	115.8	116.5	116.5	116.3	118.3
630	116.0	115.3	113.0	114.5	113.0	113.5	113.3	113.3	114.5
800	115.3	115.3	112.8	113.8	111.8	113.0	113.0	112.5	113.3
1000	115.0	115.3	113.0	113.3	112.3	112.5	112.5	112.5	112.3
1250	114.5	114.8	112.5	113.0	112.0	112.3	112.0	112.3	112.3
1600	114.5	114.5	112.5	113.3	111.5	112.0	111.5	112.0	111.8
2000	114.3	114.0	112.3	113.3	111.5	111.5	111.5	111.8	112.0
2500	113.5	113.8	111.8	112.5	110.8	111.3	111.0	111.0	111.3
3150	113.3	113.5	111.8	112.8	111.3	111.8	111.8	111.0	112.0
4000	113.0	113.0	111.8	112.8	111.0	111.5	111.3	111.5	111.8
5000	111.8	112.0	111.3	111.5	110.5	111.3	110.5	110.5	110.8

NA Not Available

TABLE D.1 (CONTINUED)

ONE-THIRD OCTAVE BAND SOUND PRESSURE LEVELS. FLIGHT #3
EXTERIOR MICROPHONE, PORT SIDE.

Band Center Frequency Hz	One-Third Octave Band Sound Pressure Level, dB re 20 micro Pa								
	Test Condition								
	10	11	12	13	14	15	16	17	18
25	96.3	91.8	93.5	93.0	93.3	93.5	92.8	92.8	93.5
32	97.0	93.0	93.3	93.3	92.3	92.8	93.3	93.5	93.5
40	99.8	96.0	95.8	94.8	95.0	94.3	94.8	94.8	95.3
50	103.3	97.8	99.8	97.5	98.0	98.0	98.0	98.3	98.3
63	115.0	101.0	113.8	111.3	110.3	109.3	111.3	107.5	110.5
80	129.3	109.8	127.5	125.5	124.5	123.3	125.8	124.5	124.5
100	109.8	102.0	107.0	105.0	104.8	104.3	105.8	106.8	104.8
125	114.3	104.5	111.5	109.8	108.5	110.3	110.3	107.3	109.8
160	128.3	109.5	125.3	124.0	121.8	124.3	124.0	124.0	123.3
200	118.5	104.8	115.0	114.3	114.0	114.0	113.5	112.8	115.0
250	124.5	105.8	120.0	120.5	120.0	120.3	120.3	122.8	120.5
315	120.8	106.5	116.8	115.5	117.3	118.3	116.3	118.8	117.3
400	117.5	106.8	113.0	113.3	115.0	115.0	114.8	116.0	114.8
500	116.3	108.0	109.5	111.8	113.0	113.8	113.5	114.5	112.8
630	113.3	107.8	107.8	109.3	109.8	110.5	109.8	111.5	109.3
800	112.3	108.3	108.3	108.0	109.0	109.3	108.8	110.3	108.5
1000	112.5	108.5	108.0	108.0	108.5	108.5	108.5	109.4	108.0
1250	111.5	108.8	108.3	107.8	108.0	108.5	108.0	108.5	108.3
1600	112.0	109.3	107.8	107.8	108.3	108.5	108.0	108.0	108.5
2000	111.5	108.3	107.8	107.3	108.0	108.5	108.0	107.5	108.0
2500	111.0	108.3	107.5	107.3	107.5	108.0	107.3	107.5	107.5
3150	110.5	108.3	107.8	107.5	107.8	107.8	107.5	107.5	107.8
4000	110.5	108.0	107.3	107.0	107.3	107.3	107.5	106.8	107.5
5000	110.8	107.5	106.0	106.8	107.3	107.0	107.3	106.5	107.3

NA Not Available

TABLE D.2

ONE-THIRD OCTAVE BAND SOUND PRESSURE LEVELS. FLIGHT #3
EXTERIOR MICROPHONE, STARBOARD SIDE.

Band Center Frequency Hz	One-Third Octave Band Sound Pressure Level, dB re 20 micro Pa								
	Test Condition								
	1	2	3	4	5	6	7	8	9
25	107.0	107.8	102.0	101.8	100.0	101.3	101.5	101.5	101.0
32	106.5	108.3	102.0	101.8	100.8	101.5	102.3	101.3	101.8
40	109.0	108.8	103.3	104.3	102.5	103.0	103.0	102.8	103.5
50	110.0	110.8	105.3	105.0	104.5	104.5	104.8	104.5	105.0
63	116.8	114.5	112.0	115.3	112.8	113.0	114.5	113.3	114.0
80	129.3	129.0	128.0	128.3	127.0	127.3	129.0	127.3	127.5
100	114.0	115.3	112.3	111.0	109.8	110.3	110.8	110.5	110.3
125	116.3	115.3	112.3	114.5	113.5	112.5	113.5	113.3	113.5
160	126.5	126.5	126.0	126.0	126.5	125.0	126.0	126.0	125.5
200	118.3	117.5	114.5	116.0	115.3	115.8	115.5	115.8	116.0
250	122.0	122.5	121.8	120.5	121.3	120.8	121.5	121.5	120.5
315	118.8	119.3	118.8	118.5	119.0	119.0	118.3	118.5	118.5
400	118.5	119.3	116.8	116.8	116.0	117.0	116.3	116.5	116.3
500	119.0	120.3	116.3	116.3	115.0	116.0	115.8	115.5	115.0
630	119.3	120.0	115.3	115.8	114.0	114.5	114.3	114.0	114.5
800	119.5	120.5	115.5	116.0	113.8	114.8	114.8	114.3	114.8
1000	120.0	121.0	115.5	116.3	114.0	114.5	114.8	114.8	114.5
1250	119.8	120.3	115.3	116.0	113.8	114.5	114.5	114.5	114.0
1600	119.8	119.8	115.5	115.8	113.5	114.3	114.3	114.3	114.0
2000	119.0	119.8	115.5	115.5	113.3	113.5	114.0	114.0	113.8
2500	118.0	118.3	114.0	114.8	112.5	113.3	113.5	113.5	113.3
3150	117.5	117.8	114.0	114.5	112.0	113.0	113.3	113.3	112.5
4000	115.8	116.3	113.3	113.8	111.3	113.0	112.3	112.3	112.0
5000	113.5	115.0	111.5	112.3	109.8	111.0	110.8	111.3	111.0

NA Not Available

TABLE D.2 (CONTINUED)

ONE-THIRD OCTAVE BAND SOUND PRESSURE LEVELS. FLIGHT #3
EXTERIOR MICROPHONE, STARBOARD SIDE.

Band Center Frequency Hz	One-Third Octave Band Sound Pressure Level, dB re 20 micro Pa								
	Test Condition								
	10	11	12	13	14	15	16	17	18
25	101.8	97.8	94.8	96.3	95.5	96.8	96.5	95.5	96.3
32	102.0	98.3	97.3	96.8	97.3	97.3	96.0	97.0	97.8
40	102.8	110.3	99.3	98.5	98.5	98.8	99.0	98.3	98.8
50	104.5	102.0	100.8	100.5	101.0	100.8	101.0	100.5	100.3
63	111.3	114.8	102.8	111.8	110.5	111.0	111.8	111.3	108.5
80	128.0	128.0	110.8	125.8	124.5	125.0	125.8	125.0	125.3
100	112.3	108.0	105.3	106.8	106.8	106.8	107.0	106.3	108.5
125	112.3	112.8	106.8	110.8	111.0	110.8	111.0	111.5	109.0
160	126.3	125.3	108.0	124.3	125.0	124.0	124.8	124.3	125.3
200	114.5	115.8	106.8	115.0	114.5	114.5	115.0	115.3	113.3
250	122.3	120.8	106.5	121.0	121.3	121.0	121.0	120.3	122.0
315	119.3	116.8	107.3	119.0	119.0	118.8	118.8	118.3	120.3
400	117.0	113.3	108.0	116.8	116.5	117.0	117.3	116.0	118.8
500	116.5	110.8	108.5	114.5	115.0	115.0	114.8	113.5	117.5
630	114.3	109.8	108.0	110.5	110.5	111.0	111.0	109.8	113.0
800	115.0	109.3	108.5	108.5	108.5	108.8	108.3	108.5	111.0
1000	114.8	109.5	109.0	107.5	108.3	108.5	108.3	107.5	109.0
1250	114.0	108.8	108.5	107.3	107.5	107.3	107.3	107.3	108.0
1600	114.3	109.0	109.0	107.0	107.8	107.0	107.3	107.0	107.8
2000	113.8	108.8	108.5	106.8	107.0	107.0	107.3	107.5	108.3
2500	113.3	107.8	108.5	106.3	106.8	106.8	106.8	106.5	107.3
3150	112.5	107.8	108.0	106.5	106.8	106.5	106.5	106.8	106.8
4000	111.5	107.0	108.0	106.3	106.3	106.8	106.3	106.0	105.5
5000	110.5	105.8	106.8	105.0	105.3	105.3	105.0	104.5	105.3

NA Not Available

TABLE D.3

ONE-THIRD OCTAVE BAND SOUND PRESSURE LEVELS. FLIGHT #4
EXTERIOR MICROPHONE, PORT SIDE.

Band Center Frequency Hz	One-Third Octave Band Sound Pressure Level, dB re 20 micro Pa								
	Test Condition								
	1	2	3	4	5	6	7	8	9
25	104.8	104.3	102.0	102.5	NA	NA	NA	NA	100.5
32	106.0	104.8	101.5	102.3	NA	NA	NA	NA	100.8
40	107.3	107.3	104.0	103.8	NA	NA	NA	NA	102.5
50	111.0	111.0	108.5	108.5	NA	NA	NA	NA	107.0
63	117.0	120.3	118.5	115.3	NA	NA	NA	NA	114.0
80	134.3	134.3	132.5	132.5	NA	NA	NA	NA	131.8
100	117.5	116.0	113.8	115.3	NA	NA	NA	NA	114.0
125	118.5	120.5	118.0	116.0	NA	NA	NA	NA	114.8
160	134.0	133.5	132.0	132.0	NA	NA	NA	NA	131.8
200	122.3	124.0	122.0	120.0	NA	NA	NA	NA	119.5
250	131.3	129.8	128.3	129.5	NA	NA	NA	NA	129.0
315	127.3	126.0	124.3	125.3	NA	NA	NA	NA	125.3
400	124.3	123.0	120.8	122.0	NA	NA	NA	NA	122.0
500	123.5	122.3	119.8	121.3	NA	NA	NA	NA	120.8
630	120.0	119.5	117.3	118.0	NA	NA	NA	NA	117.0
800	119.8	118.8	116.8	117.0	NA	NA	NA	NA	116.0
1000	119.0	119.5	116.8	116.8	NA	NA	NA	NA	115.3
1250	118.8	119.0	116.3	115.8	NA	NA	NA	NA	114.5
1600	118.8	118.8	116.0	116.0	NA	NA	NA	NA	114.5
2000	118.5	118.8	116.0	115.8	NA	NA	NA	NA	114.5
2500	118.0	118.0	115.5	115.8	NA	NA	NA	NA	114.0
3150	117.5	117.3	115.5	115.8	NA	NA	NA	NA	114.0
4000	117.5	117.0	115.8	115.5	NA	NA	NA	NA	114.0
5000	116.5	115.8	114.3	114.5	NA	NA	NA	NA	113.0

NA Not Available

TABLE D.3 (CONTINUED)

ONE-THIRD OCTAVE BAND SOUND PRESSURE LEVELS, FLIGHT #4
EXTERIOR MICROPHONE, PORT SIDE.

Band Center Frequency Hz	One-Third Octave Band Sound Pressure Level, dB re 20 micro Pa								
	Test Condition								
	10	11	12	13	14	15	16	17	18
25	100.8	94.0	95.8	93.8	NA	NA	NA	94.8	95.0
32	100.3	96.3	96.3	95.0	NA	NA	NA	95.0	94.5
40	102.8	98.8	99.0	96.5	NA	NA	NA	96.5	96.8
50	106.8	100.0	102.3	100.0	NA	NA	NA	101.0	100.8
63	118.0	102.8	115.5	112.8	NA	NA	NA	109.5	112.5
80	132.0	111.3	129.5	126.3	NA	NA	NA	126.5	126.5
100	112.3	105.3	109.3	106.5	NA	NA	NA	109.0	106.8
125	117.5	107.0	114.0	112.0	NA	NA	NA	110.5	112.5
160	131.3	112.3	127.5	125.5	NA	NA	NA	127.0	126.0
200	122.0	107.8	117.3	116.8	NA	NA	NA	115.5	117.8
250	128.0	109.0	123.0	122.3	NA	NA	NA	125.8	123.5
315	124.0	108.8	119.3	118.3	NA	NA	NA	121.5	119.5
400	121.5	109.8	115.0	116.0	NA	NA	NA	119.0	117.5
500	120.0	110.5	112.5	114.0	NA	NA	NA	118.3	115.5
630	116.8	110.5	109.8	111.0	NA	NA	NA	114.5	112.3
800	116.0	111.5	110.3	110.5	NA	NA	NA	113.3	110.5
1000	115.3	111.8	111.0	110.3	NA	NA	NA	111.0	110.5
1250	114.3	112.0	110.3	109.8	NA	NA	NA	111.0	110.8
1600	114.8	112.0	110.8	109.8	NA	NA	NA	110.5	110.5
2000	114.5	111.5	110.3	109.8	NA	NA	NA	110.5	110.3
2500	114.0	111.5	109.8	109.5	NA	NA	NA	110.3	110.5
3150	114.5	111.5	109.8	109.5	NA	NA	NA	110.3	110.3
4000	114.3	111.0	109.8	109.8	NA	NA	NA	110.5	110.0
5000	113.8	110.3	109.0	108.8	NA	NA	NA	109.5	109.3

NA Not Available

TABLE D.4

ONE-THIRD OCTAVE BAND SOUND PRESSURE LEVELS. FLIGHT #4
 EXTERIOR MICROPHONE, STARBOARD SIDE.

Band Center Frequency Hz	One-Third Octave Band Sound Pressure Level, dB re 20 micro Pa								
	Test Condition								
	1	2	3	4	5	6	7	8	9
25	107.0	107.5	102.8	102.0	NA	NA	NA	NA	100.0
32	107.0	108.5	101.3	101.8	NA	NA	NA	NA	100.0
40	108.5	109.8	104.0	103.5	NA	NA	NA	NA	101.8
50	109.3	111.0	105.3	105.8	NA	NA	NA	NA	103.5
63	117.0	114.5	112.3	115.3	NA	NA	NA	NA	113.8
80	130.0	129.3	128.8	128.8	NA	NA	NA	NA	127.8
100	114.5	115.8	112.5	110.8	NA	NA	NA	NA	109.8
125	116.5	116.0	112.8	114.3	NA	NA	NA	NA	112.8
160	127.0	127.0	127.0	126.0	NA	NA	NA	NA	125.8
200	118.5	117.5	115.0	116.5	NA	NA	NA	NA	115.8
250	121.5	122.5	122.5	120.8	NA	NA	NA	NA	121.5
315	119.5	119.8	119.3	118.3	NA	NA	NA	NA	118.5
400	118.5	119.5	117.3	116.5	NA	NA	NA	NA	116.3
500	119.0	120.5	116.8	116.0	NA	NA	NA	NA	115.0
630	119.0	120.5	115.8	115.5	NA	NA	NA	NA	114.0
800	119.0	121.3	115.5	115.5	NA	NA	NA	NA	113.8
1000	119.5	121.3	115.8	115.8	NA	NA	NA	NA	114.0
1250	119.0	120.8	116.0	115.5	NA	NA	NA	NA	113.5
1600	118.5	120.5	115.8	114.8	NA	NA	NA	NA	113.5
2000	118.5	119.8	115.8	115.0	NA	NA	NA	NA	113.3
2500	117.8	119.0	115.0	114.8	NA	NA	NA	NA	112.5
3150	116.8	118.5	113.5	114.5	NA	NA	NA	NA	112.3
4000	115.8	116.3	113.0	113.3	NA	NA	NA	NA	111.0
5000	113.8	115.8	112.0	111.0	NA	NA	NA	NA	109.8

NA Not Available

TABLE D.4 (CONTINUED)

ONE-THIRD OCTAVE BAND SOUND PRESSURE LEVELS. FLIGHT #4
EXTERIOR MICROPHONE, STARBOARD SIDE.

Band Center Frequency Hz	One-Third Octave Band Sound Pressure Level, dB re 20 micro Pa								
	Test Condition								
	10	11	12	13	14	15	16	17	18
25	101.0	97.8	93.0	95.3	NA	NA	NA	93.8	94.8
32	101.3	97.3	95.3	94.8	NA	NA	NA	95.3	94.8
40	103.0	98.5	97.0	96.5	NA	NA	NA	97.0	97.0
50	104.3	101.5	99.8	98.8	NA	NA	NA	98.8	99.0
63	111.3	115.0	102.3	112.3	NA	NA	NA	111.5	108.3
80	128.0	128.5	111.0	125.8	NA	NA	NA	125.0	125.3
100	111.5	108.5	104.3	106.0	NA	NA	NA	105.3	108.0
125	111.8	113.0	106.3	111.3	NA	NA	NA	110.8	108.3
160	126.8	125.5	107.3	124.5	NA	NA	NA	124.0	125.0
200	114.8	116.5	105.8	116.0	NA	NA	NA	115.3	112.5
250	123.0	121.0	106.0	121.0	NA	NA	NA	120.3	122.5
315	119.8	117.0	106.5	118.5	NA	NA	NA	118.0	120.0
400	117.5	113.8	106.8	115.8	NA	NA	NA	115.8	118.0
500	116.5	111.0	108.0	113.5	NA	NA	NA	113.8	117.0
630	114.5	110.5	107.8	110.3	NA	NA	NA	109.8	112.5
800	115.0	109.8	108.5	107.3	NA	NA	NA	107.8	110.5
1000	114.3	110.3	109.0	107.5	NA	NA	NA	107.8	108.5
1250	114.8	109.3	109.3	106.8	NA	NA	NA	106.8	107.8
1600	114.0	109.8	108.8	106.8	NA	NA	NA	106.8	107.5
2000	113.8	108.8	108.8	106.3	NA	NA	NA	106.8	107.3
2500	113.3	108.5	108.8	106.8	NA	NA	NA	106.8	107.0
3150	112.3	108.5	108.8	106.3	NA	NA	NA	106.3	106.5
4000	112.0	108.0	107.8	106.0	NA	NA	NA	106.0	106.5
5000	111.3	105.8	106.8	105.0	NA	NA	NA	104.8	105.0

NA Not Available

APPENDIX E

One-Third Octave Band Spectra for Interior Sound Pressures:
Flight 3, Bare Interior.

TABLE E.1

ONE-THIRD OCTAVE BAND SOUND PRESSURE LEVELS. FLIGHT #3
CABIN MICROPHONE NUMBER 1

Band Center Frequency Hz	One-Third Octave Band Sound Pressure Level, dB re 20 micro Pa								
	Test Condition								
	1	2	3	4	5	6	7	8	9
25	84.5	84.3	87.3	86.0	90.3	90.0	88.8	87.0	89.0
32	85.0	85.0	78.3	80.3	80.0	80.5	80.0	79.8	82.0
40	74.8	75.3	69.0	69.5	68.5	68.3	69.0	69.3	69.5
50	78.0	77.8	77.0	77.8	77.0	74.5	79.0	78.0	78.0
63	94.3	96.0	96.8	96.3	96.5	92.3	98.5	97.8	95.8
80	111.5	110.8	111.5	113.8	111.3	107.0	113.3	112.3	113.8
100	92.5	89.8	90.8	94.3	90.3	86.8	91.5	91.0	94.5
125	85.8	84.0	84.5	86.8	83.8	86.8	84.5	85.8	85.3
160	97.3	95.0	95.5	96.5	92.5	98.5	92.8	96.0	95.3
200	92.5	89.3	87.0	88.5	87.8	89.0	89.3	89.8	89.0
250	97.3	93.8	91.5	92.0	88.5	92.5	93.3	93.3	91.8
315	90.0	89.0	93.0	94.5	87.8	93.3	92.5	89.3	92.5
400	84.5	85.0	87.0	87.5	86.5	88.0	87.8	87.3	86.8
500	87.5	87.5	89.0	90.3	91.0	91.5	91.0	90.0	90.8
630	86.8	86.8	87.8	87.3	86.8	86.8	87.3	87.3	87.5
800	85.0	84.8	85.0	85.3	85.0	85.5	85.5	85.3	85.5
1000	85.5	84.5	84.5	86.5	85.5	86.3	86.0	86.0	86.3
1250	84.8	84.8	82.3	83.5	82.3	83.5	83.8	83.8	83.8
1600	82.5	82.8	81.0	81.3	79.8	81.3	81.8	81.0	81.0
2000	79.5	78.8	79.0	79.8	78.8	80.0	80.8	79.8	80.5
2500	76.5	76.0	77.0	77.8	75.8	77.8	77.8	77.0	77.3
3150	72.3	71.5	73.8	74.8	73.5	74.8	75.8	74.3	74.8
4000	70.5	70.0	72.3	73.0	70.8	72.0	73.3	71.5	72.5
5000	67.5	67.0	69.8	70.3	68.0	70.0	71.3	69.8	70.3

NA Not Available

TABLE E.1 (CONTINUED)

ONE-THIRD OCTAVE BAND SOUND PRESSURE LEVELS, FLIGHT #3
CABIN MICROPHONE NUMBER 1

Band Center Frequency Hz	One-Third Octave Band Sound Pressure Level, dB re 20 micro Pa								
	Test Condition								
	10	11	12	13	14	15	16	17	18
25	88.5	78.8	85.0	93.5	93.0	92.5	90.3	93.8	91.5
32	80.8	79.8	79.8	81.3	81.5	80.0	79.5	82.5	80.3
40	69.0	66.5	68.3	65.3	65.3	64.5	65.3	66.0	65.5
50	77.3	70.0	74.5	70.8	69.5	65.8	70.5	71.0	71.0
63	97.0	87.5	94.5	90.3	88.5	84.5	90.5	88.3	88.8
80	111.8	101.0	108.5	104.5	102.8	98.5	104.8	105.5	103.5
100	91.0	81.8	86.3	83.0	82.5	79.8	83.3	86.3	83.5
125	85.8	81.0	81.0	85.3	80.3	83.0	84.8	81.0	82.5
160	96.8	83.5	84.0	98.8	85.3	95.8	97.8	90.8	95.8
200	88.8	84.3	81.5	84.3	87.0	86.5	86.8	86.5	88.5
250	92.0	87.5	83.0	87.3	92.0	91.5	91.8	92.3	94.3
315	92.8	83.5	84.5	86.5	85.5	85.5	83.0	81.5	91.0
400	88.0	83.5	81.3	84.5	82.5	84.0	86.0	84.5	86.3
500	90.8	85.8	84.0	88.8	88.0	88.5	87.3	90.3	87.5
630	86.5	80.3	79.0	82.5	81.8	82.3	82.0	83.3	83.0
800	84.8	79.3	78.0	79.0	79.3	79.0	80.0	80.0	80.8
1000	86.0	78.8	79.0	79.5	80.5	80.0	80.3	80.5	80.8
1250	83.5	75.8	75.3	78.5	78.8	78.8	79.0	78.8	78.8
1600	81.5	74.5	73.8	77.0	78.0	78.8	78.8	77.8	77.3
2000	80.0	72.5	73.3	74.3	73.3	75.0	74.8	74.3	74.0
2500	77.0	70.8	70.8	71.3	70.0	71.8	71.8	70.8	70.8
3150	75.0	69.0	69.0	69.3	67.8	69.3	70.3	69.0	69.0
4000	72.3	66.3	66.8	67.5	64.8	67.8	68.3	67.0	67.0
5000	69.8	65.0	67.3	65.0	63.0	65.8	66.3	64.8	65.0

NA Not Available

TABLE E.2

ONE-THIRD OCTAVE BAND SOUND PRESSURE LEVELS, FLIGHT #3
CABIN MICROPHONE NUMBER 2

Band Center Frequency Hz	One-Third Octave Band Sound Pressure Level, dB re 20 micro Pa								
	Test Condition								
	1	2	3	4	5	6	7	8	9
25	79.3	79.0	81.3	80.8	85.3	85.0	83.5	81.8	84.0
32	80.5	80.0	73.3	75.5	74.8	75.5	75.3	75.0	76.8
40	72.5	73.3	66.8	67.5	66.3	65.0	66.8	67.0	66.8
50	80.3	79.5	78.5	80.0	77.8	76.0	79.3	79.0	79.3
63	94.5	96.8	97.0	96.0	96.5	93.5	98.3	97.3	95.5
80	111.8	111.3	111.8	113.5	111.3	108.5	113.0	112.3	113.3
100	92.8	89.8	90.0	94.0	89.5	87.5	90.8	90.5	94.0
125	87.0	86.5	89.0	89.0	89.3	90.3	89.3	90.8	89.8
160	94.0	94.0	97.3	96.5	100.3	102.0	95.5	103.0	100.3
200	88.0	88.0	88.3	87.0	87.8	89.0	90.5	90.8	89.0
250	91.8	91.0	92.5	94.5	91.0	93.3	95.3	95.8	94.3
315	91.5	89.0	92.8	97.5	92.5	89.0	88.5	90.8	94.3
400	87.0	86.8	88.8	90.0	89.8	91.0	89.8	90.3	90.8
500	86.8	86.8	89.0	90.3	90.8	92.8	92.5	92.0	93.0
630	88.0	86.8	88.5	90.3	89.3	89.0	89.8	88.5	90.3
800	87.0	86.8	87.5	88.5	86.5	87.5	87.0	87.8	88.0
1000	86.5	85.8	86.8	87.3	87.3	87.3	87.0	87.8	88.3
1250	85.0	85.0	84.3	85.3	84.3	85.0	85.0	85.0	84.8
1600	83.0	81.8	81.3	82.8	81.5	82.5	83.3	82.3	82.5
2000	80.0	80.0	80.0	80.8	79.3	80.3	80.3	80.5	80.8
2500	77.0	76.3	77.0	78.0	76.8	78.5	79.5	78.3	78.5
3150	73.5	73.3	75.5	76.3	74.8	76.3	76.5	75.3	76.0
4000	72.0	71.3	74.3	75.0	72.5	74.3	75.3	73.3	74.3
5000	70.5	69.5	73.3	72.8	70.5	72.8	74.0	71.5	72.3

NA Not Available

TABLE E.2 (CONTINUED)

ONE-THIRD OCTAVE BAND SOUND PRESSURE LEVELS. FLIGHT #3
CABIN MICROPHONE NUMBER 2

Band Center Frequency Hz	One-Third Octave Band Sound Pressure Level, dB re 20 micro Pa								
	Test Condition								
	10	11	12	13	14	15	16	17	18
25	83.3	73.8	80.3	88.0	88.0	86.8	84.8	88.0	85.8
32	75.0	75.5	75.3	76.8	76.8	75.3	75.0	77.3	75.0
40	66.5	62.0	65.0	61.0	61.0	60.0	61.0	61.3	60.8
50	77.5	71.5	75.8	70.8	71.0	69.5	71.0	72.0	71.5
63	97.0	85.5	95.3	88.8	88.5	85.3	88.5	86.8	88.0
80	111.8	98.5	109.0	103.0	103.0	99.5	103.0	104.3	102.5
100	90.0	78.8	86.3	82.0	81.8	79.3	81.8	85.0	82.0
125	90.5	84.0	87.3	86.3	85.5	85.0	87.0	85.0	86.5
160	100.5	88.5	96.3	97.5	91.8	92.5	98.5	93.8	95.3
200	89.5	82.8	84.5	85.5	83.8	83.5	84.5	85.3	83.3
250	93.8	85.5	89.3	88.5	85.8	84.8	85.5	90.3	84.5
315	91.0	84.3	85.8	91.3	91.5	89.3	86.5	87.5	90.0
400	91.0	84.8	83.0	88.0	86.8	87.0	86.0	87.5	90.0
500	91.8	85.5	85.0	92.3	88.8	88.8	89.3	94.0	92.0
630	88.5	81.5	82.5	84.8	85.3	85.0	84.8	86.0	85.3
800	87.8	81.8	81.0	82.0	81.5	82.0	81.8	82.5	83.0
1000	87.5	80.8	81.3	81.5	81.0	81.8	81.5	81.5	82.0
1250	84.8	77.0	76.3	79.3	79.3	80.5	80.8	79.8	79.8
1600	82.3	75.3	74.3	78.0	78.5	79.5	79.5	77.8	80.3
2000	80.0	73.5	74.0	74.3	73.5	74.5	74.8	74.3	74.5
2500	78.0	72.0	72.0	72.0	71.3	72.5	72.8	72.0	72.3
3150	75.8	70.3	70.3	70.8	68.8	71.0	71.8	70.0	70.8
4000	74.3	67.8	68.8	69.3	66.8	69.5	69.8	68.5	68.8
5000	71.5	67.3	69.5	67.5	65.0	67.8	68.0	66.5	67.0

NA Not Available

TABLE E.3

ONE-THIRD OCTAVE BAND SOUND PRESSURE LEVELS, FLIGHT #3
CABIN MICROPHONE NUMBER 3

Band Center Frequency Hz	One-Third Octave Band Sound Pressure Level, dB re 20 micro Pa								
	Test Condition								
	1	2	3	4	5	6	7	8	9
25	74.5	75.3	77.3	75.0	78.5	78.3	76.0	76.0	78.3
32	72.8	73.0	69.0	69.3	69.3	69.3	68.0	73.8	71.0
40	66.8	66.5	62.8	63.8	62.5	63.5	62.5	70.0	63.0
50	80.5	79.0	76.5	79.0	76.5	76.5	75.0	76.8	76.8
63	89.8	90.0	86.8	87.0	86.0	91.5	88.8	83.0	87.3
80	106.5	103.8	100.5	102.0	99.0	106.3	102.5	93.0	100.3
100	89.0	85.5	86.0	87.0	85.3	88.0	86.8	86.3	86.3
125	88.0	86.5	88.8	88.8	89.3	90.5	87.5	91.0	89.0
160	98.5	96.3	98.3	97.0	101.3	102.8	95.0	104.8	99.8
200	95.3	93.0	91.3	92.3	88.0	91.0	90.8	91.8	91.5
250	100.3	98.8	97.5	100.0	89.5	95.5	95.5	96.3	98.3
315	90.8	90.3	91.0	89.3	90.3	91.8	91.8	89.5	90.3
400	89.8	88.5	90.3	93.3	92.0	91.8	90.3	91.5	91.5
500	89.0	88.3	93.5	94.0	93.0	92.5	93.0	93.0	92.3
630	92.8	91.0	93.3	93.5	92.8	95.3	95.3	93.5	93.8
800	90.3	89.3	90.8	92.0	90.8	91.5	91.8	91.3	91.5
1000	88.5	88.0	89.5	91.0	90.0	90.8	90.8	90.5	90.5
1250	86.5	85.8	86.3	87.3	86.0	87.3	87.0	87.3	87.3
1600	85.0	84.5	83.8	85.3	84.0	85.0	85.0	85.0	85.0
2000	82.3	82.5	81.3	82.5	81.5	82.5	82.8	82.5	82.5
2500	79.0	78.8	78.3	79.5	78.8	79.5	80.0	79.8	80.0
3150	74.8	74.3	76.0	77.3	76.5	76.8	77.8	77.3	77.3
4000	73.5	73.0	74.5	75.8	74.0	75.0	75.5	74.8	75.3
5000	71.3	71.0	73.0	73.5	73.0	73.3	73.8	73.0	73.5

NA Not Available

TABLE E.3 (CONTINUED)

ONE-THIRD OCTAVE BAND SOUND PRESSURE LEVELS. FLIGHT #3
CABIN MICROPHONE NUMBER 3

Band Center Frequency Hz	One-Third Octave Band Sound Pressure Level, dB re 20 micro Pa								
	Test Condition								
	10	11	12	13	14	15	16	17	18
25	77.3	70.3	75.5	83.0	72.8	82.3	81.0	82.8	80.8
32	69.8	69.0	69.3	70.3	70.8	69.8	69.0	71.8	69.8
40	63.3	61.8	62.3	62.0	61.8	63.0	62.5	62.3	62.5
50	75.8	73.5	74.8	71.3	71.8	72.5	72.5	73.0	72.0
63	88.0	87.0	87.5	83.8	82.5	88.8	85.3	83.5	86.3
80	103.3	100.0	101.3	97.0	95.5	103.0	99.0	98.0	101.0
100	86.8	83.8	83.8	82.5	83.3	84.3	83.3	83.0	84.8
125	89.8	85.3	88.0	85.0	85.3	87.0	83.8	84.3	85.5
160	101.8	92.8	97.3	96.3	96.3	99.5	92.3	96.3	97.3
200	90.3	86.3	83.5	84.3	85.8	86.3	85.5	84.8	85.5
250	95.0	90.5	87.0	84.8	88.8	89.3	88.5	84.5	88.0
315	91.0	85.5	81.0	85.5	89.3	88.3	86.5	86.8	87.3
400	90.3	85.5	84.0	90.8	90.5	90.5	89.8	91.5	89.5
500	93.5	87.0	85.8	95.5	95.5	95.8	95.0	96.5	96.0
630	93.8	89.3	87.5	90.5	90.0	90.0	89.3	88.3	92.0
800	91.5	85.3	83.8	86.0	86.0	86.5	86.5	86.0	87.3
1000	90.8	83.5	82.5	84.0	84.5	84.8	84.5	84.3	84.3
1250	87.0	79.3	78.3	82.8	83.3	83.8	83.3	83.0	83.3
1600	84.5	77.8	77.3	80.8	82.0	81.0	80.8	80.3	80.5
2000	82.3	75.5	76.8	77.0	76.5	77.3	77.8	76.8	77.3
2500	79.5	74.3	74.0	74.8	73.8	74.5	74.3	74.3	74.8
3150	77.0	71.0	71.5	72.5	71.0	72.0	73.0	72.5	72.5
4000	74.8	69.3	70.0	71.0	69.8	71.0	71.5	70.8	70.8
5000	73.3	68.3	70.5	70.0	68.5	69.5	70.5	69.5	69.5

NA Not Available

TABLE E.4

ONE-THIRD OCTAVE BAND SOUND PRESSURE LEVELS. FLIGHT #3
CABIN MICROPHONE NUMBER 4

Band Center Frequency Hz	One-Third Octave Band Sound Pressure Level, dB re 20 micro Pa								
	Test Condition								
	1	2	3	4	5	6	7	8	9
25	85.0	85.8	88.5	86.8	91.0	90.8	89.5	88.3	90.0
32	75.3	85.3	79.5	80.8	80.5	81.0	80.3	80.8	82.8
40	71.8	72.5	69.3	70.3	69.0	69.8	69.0	69.3	69.8
50	74.3	73.5	73.0	74.3	73.5	73.0	75.3	74.0	74.5
63	92.0	90.0	87.8	92.3	90.3	86.0	92.5	91.5	92.3
80	109.3	105.0	104.0	108.5	104.5	100.0	107.5	106.5	108.3
100	90.3	86.0	87.0	89.8	86.5	84.0	88.0	87.8	89.3
125	87.8	87.0	88.8	87.8	88.8	86.0	87.0	89.3	87.5
160	95.0	95.3	101.3	102.3	101.5	95.3	97.5	102.0	100.5
200	88.0	88.3	86.0	88.5	87.0	85.5	85.0	86.0	87.0
250	88.5	87.5	85.5	85.8	86.5	87.0	87.3	87.8	88.5
315	90.3	88.8	90.5	92.8	90.3	90.5	91.8	92.0	93.8
400	90.5	89.0	91.5	92.3	92.5	91.0	92.5	91.5	92.0
500	89.8	89.5	92.5	93.3	92.3	92.3	92.0	92.0	92.8
630	91.0	90.0	91.8	94.0	94.5	94.3	95.0	94.5	94.3
800	89.5	89.0	91.3	92.8	91.0	91.5	91.8	92.0	92.0
1000	89.3	88.8	91.3	92.5	90.8	91.0	91.5	91.3	91.0
1250	87.5	87.3	87.3	88.5	88.3	88.8	88.5	88.5	88.8
1600	85.5	85.3	84.0	85.5	84.8	85.5	85.5	85.5	85.0
2000	82.0	81.5	81.3	82.3	81.3	82.5	82.3	82.5	82.5
2500	78.5	77.5	77.0	78.5	77.5	78.3	79.0	78.5	78.5
3150	73.5	73.0	75.0	76.0	75.0	76.0	76.5	76.5	76.3
4000	71.5	70.8	72.8	74.0	72.5	73.8	74.5	73.3	73.5
5000	69.3	69.0	70.8	71.8	71.3	71.3	72.3	71.8	72.0

NA Not Available

TABLE E.4 (CONTINUED)

ONE-THIRD OCTAVE BAND SOUND PRESSURE LEVELS, FLIGHT #3
CABIN MICROPHONE NUMBER 4

Band Center Frequency Hz	One-Third Octave Band Sound Pressure Level, dB re 20 micro Pa								
	Test Condition								
	10	11	12	13	14	15	16	17	18
25	89.3	80.5	86.5	94.8	94.5	93.8	92.3	95.3	93.0
32	81.0	81.0	80.8	82.0	82.3	80.8	80.5	83.0	81.3
40	69.8	68.8	68.8	68.3	68.5	69.0	68.5	69.0	69.0
50	73.3	71.3	65.5	68.8	66.0	69.0	69.0	69.5	70.0
63	89.3	90.5	73.5	85.3	75.0	88.0	87.8	86.5	85.5
80	106.5	103.8	85.5	100.0	88.3	102.3	102.3	102.0	102.5
100	88.8	83.8	81.0	81.8	80.5	83.0	82.8	83.8	84.5
125	88.0	82.8	86.3	81.5	82.0	82.5	81.8	81.5	82.5
160	98.3	91.3	97.5	91.0	89.8	94.3	90.0	90.5	93.0
200	86.8	81.8	79.8	83.5	83.8	93.8	83.5	83.8	84.3
250	88.8	78.3	80.8	77.8	83.3	82.5	81.5	84.0	79.8
315	89.3	85.0	83.0	84.3	84.0	84.5	85.0	84.8	86.0
400	92.0	88.5	86.5	89.3	89.5	89.3	88.5	88.3	91.8
500	92.3	88.0	85.3	93.0	91.5	92.0	90.0	91.0	90.5
630	92.5	91.0	84.5	89.5	90.5	90.3	90.8	91.5	90.0
800	91.0	86.3	83.8	84.5	86.0	85.8	86.3	86.5	86.5
1000	91.0	84.8	83.5	84.5	85.0	86.0	85.5	85.3	85.8
1250	88.0	82.0	79.8	83.3	83.5	83.3	84.0	83.8	84.0
1600	85.3	78.3	76.8	81.5	81.0	81.8	81.5	81.3	81.5
2000	82.0	75.3	74.8	76.0	76.5	77.0	77.0	76.3	77.0
2500	78.8	72.3	72.3	72.8	73.0	73.5	73.5	72.8	73.0
3150	75.8	70.5	70.3	72.0	71.3	71.5	72.5	71.5	71.8
4000	73.3	67.5	67.8	70.0	69.3	69.5	70.8	70.0	70.0
5000	71.0	66.3	67.8	68.8	67.8	68.3	69.0	68.8	68.5

NA Not Available

TABLE E.5

ONE-THIRD OCTAVE BAND SOUND PRESSURE LEVELS, FLIGHT #3
CABIN MICROPHONE NUMBER 5

Band Center Frequency Hz	One-Third Octave Band Sound Pressure Level, dB re 20 micro Pa								
	Test Condition								
	1	2	3	4	5	6	7	8	9
25	72.3	72.3	73.5	72.5	75.3	76.0	75.3	74.0	73.5
32	70.5	70.8	65.0	66.0	66.3	67.3	65.3	66.3	67.5
40	65.5	66.0	61.5	62.0	61.0	60.3	60.5	60.8	61.0
50	81.0	79.3	77.3	80.3	76.3	74.3	74.0	76.0	78.3
63	86.3	85.5	82.5	85.5	81.0	80.0	81.0	79.8	82.5
80	101.0	99.5	95.5	101.0	91.8	83.8	92.3	87.5	97.0
100	85.3	84.3	85.0	86.3	85.0	83.5	84.8	83.8	85.8
125	89.0	89.8	91.5	91.0	93.8	87.0	91.8	92.8	90.5
160	104.5	104.0	105.8	106.5	108.5	97.3	105.5	107.5	106.0
200	90.3	90.3	90.3	89.8	90.5	87.8	88.8	88.5	89.5
250	95.3	93.8	94.5	92.3	94.0	91.5	92.3	88.3	91.3
315	88.5	89.3	89.0	89.5	87.3	91.8	90.5	87.3	92.5
400	87.5	87.8	90.3	91.0	90.5	90.8	91.0	91.3	93.3
500	88.3	88.0	91.8	94.3	90.5	91.3	91.3	91.5	94.0
630	89.8	89.8	92.3	92.0	92.5	91.8	91.5	90.8	91.8
800	88.5	88.5	90.3	91.5	89.8	90.5	90.5	89.8	90.5
1000	87.5	87.3	89.0	89.3	88.8	89.5	89.5	89.0	89.5
1250	85.8	86.0	85.5	86.5	86.3	86.5	86.8	86.3	86.8
1600	84.8	84.0	83.0	84.3	84.0	84.0	84.5	84.3	84.0
2000	81.5	81.5	80.8	82.0	80.8	81.8	82.0	81.5	81.5
2500	77.3	77.8	77.3	78.5	77.5	78.3	78.5	78.5	78.0
3150	74.0	73.5	74.8	76.0	75.3	75.8	76.5	75.5	76.3
4000	71.8	71.0	73.3	74.3	73.3	73.5	74.5	73.5	74.5
5000	69.8	69.5	71.3	71.8	71.3	71.8	72.5	72.0	71.8

NA Not Available

TABLE E.5 (CONTINUED)

ONE-THIRD OCTAVE BAND SOUND PRESSURE LEVELS, FLIGHT #3
CABIN MICROPHONE NUMBER 5

Band Center Frequency Hz	One-Third Octave Band Sound Pressure Level, dB re 20 micro Pa								
	Test Condition								
	10	11	12	13	14	15	16	17	18
25	73.8	66.3	71.5	79.0	79.0	78.8	76.8	79.3	77.0
32	65.3	65.8	66.0	67.0	67.0	66.5	66.0	68.0	66.5
40	61.0	59.0	59.5	60.5	60.0	60.0	60.0	60.5	60.5
50	75.5	71.8	73.8	71.8	72.0	70.3	71.3	73.8	70.5
63	81.0	82.8	79.5	84.0	83.5	79.0	83.0	81.8	78.5
80	94.5	95.3	87.8	98.3	97.5	90.0	96.5	94.5	91.5
100	84.3	82.0	81.3	81.0	81.5	80.8	80.8	80.3	80.3
125	91.8	86.3	89.5	83.0	90.0	88.0	82.3	86.0	87.3
160	107.0	97.3	102.5	93.3	104.3	101.8	91.3	101.5	102.8
200	90.8	85.5	82.5	88.0	86.0	85.0	84.5	86.3	87.5
250	93.5	89.8	84.3	92.8	86.8	86.5	87.8	87.8	92.5
315	91.0	85.3	80.3	83.8	83.8	86.3	83.3	85.0	88.5
400	91.0	84.0	86.0	90.8	88.8	91.5	89.0	89.0	92.0
500	91.5	86.3	86.0	91.3	92.0	92.3	91.3	93.3	91.5
630	91.5	87.5	84.5	89.0	88.8	88.8	89.0	89.0	88.5
800	90.5	84.0	82.5	84.5	85.0	85.0	84.8	85.3	86.3
1000	89.0	82.0	81.0	83.3	83.5	83.3	83.3	83.5	83.5
1250	86.5	79.0	78.0	81.5	82.0	82.5	82.3	82.3	82.3
1600	83.5	76.8	76.8	79.3	79.5	79.8	79.3	80.0	79.5
2000	82.0	75.0	75.3	75.5	75.5	75.8	76.5	76.0	76.0
2500	78.3	72.5	73.3	72.5	72.5	72.8	73.3	73.0	73.3
3150	75.8	69.3	71.0	71.3	69.5	71.0	71.3	70.8	71.0
4000	73.8	68.0	69.0	69.8	68.0	69.0	70.0	69.0	69.0
5000	71.8	65.8	69.3	67.8	66.5	67.3	68.3	67.3	67.5

NA Not Available

TABLE E.6

ONE-THIRD OCTAVE BAND SOUND PRESSURE LEVELS, FLIGHT #3
CABIN MICROPHONE NUMBER 6

Band Center Frequency Hz	One-Third Octave Band Sound Pressure Level, dB re 20 micro Pa								
	Test Condition								
	1	2	3	4	5	6	7	8	9
25	84.8	85.3	88.3	87.3	91.0	91.3	90.5	88.8	90.5
32	85.8	86.0	80.0	81.5	81.3	82.3	81.0	81.0	83.0
40	72.5	73.0	70.0	70.8	69.5	70.0	69.5	69.8	70.3
50	73.5	73.3	73.3	75.3	73.0	72.8	75.8	74.0	74.3
63	91.5	90.8	91.0	93.3	90.0	82.0	93.5	92.5	92.5
80	108.5	106.3	106.3	110.5	104.8	96.3	108.5	107.0	110.0
100	90.0	87.3	87.5	92.0	86.0	84.3	88.5	87.5	91.5
125	86.8	86.8	86.5	87.0	88.0	84.3	86.8	88.8	87.3
160	98.8	98.3	100.0	100.3	101.5	90.8	99.3	102.0	102.0
200	88.5	89.0	87.3	85.5	85.8	84.8	85.8	87.5	86.8
250	91.3	91.5	85.3	88.8	81.5	84.5	83.0	85.8	88.5
315	91.0	90.8	89.8	92.5	90.3	90.0	89.8	90.8	91.3
400	91.5	90.8	93.0	95.3	91.5	92.3	92.3	92.3	93.8
500	90.5	89.8	93.0	93.8	92.3	93.3	92.8	92.8	93.0
630	92.8	93.0	94.5	95.0	93.5	93.5	93.8	93.3	94.3
800	90.8	90.8	92.8	93.0	91.8	92.8	92.8	93.0	92.8
1000	89.8	89.3	90.8	91.5	91.5	91.8	91.5	91.8	91.8
1250	88.5	88.0	87.5	89.3	88.5	89.0	89.3	88.5	89.0
1600	85.5	85.8	84.5	86.0	85.3	86.3	86.3	86.0	86.0
2000	83.0	82.3	81.5	82.5	82.0	82.8	83.0	83.0	83.3
2500	79.0	78.8	77.5	79.0	78.8	79.0	79.3	79.5	79.5
3150	74.0	74.0	75.3	76.3	75.8	76.5	76.8	76.0	76.0
4000	71.5	71.0	72.5	73.8	73.0	73.8	74.0	73.8	73.8
5000	69.3	68.8	70.3	71.5	71.0	71.0	72.0	71.0	71.5

NA Not Available

TABLE E.6 (CONTINUED)

ONE-THIRD OCTAVE BAND SOUND PRESSURE LEVELS, FLIGHT #3
CABIN MICROPHONE NUMBER 6

Band Center Frequency Hz	One-Third Octave Band Sound Pressure Level, dB re 20 micro Pa								
	Test Condition								
	10	11	12	13	14	15	16	17	18
25	89.5	81.3	86.8	95.0	95.0	94.3	92.0	95.0	93.0
32	81.5	82.0	80.8	82.5	82.8	81.8	81.0	84.0	81.5
40	70.0	69.3	69.3	69.0	69.0	69.0	69.0	69.3	69.5
50	73.8	70.0	68.0	66.3	64.0	66.5	67.3	67.5	67.8
63	90.8	86.8	84.3	83.8	76.5	84.5	86.0	85.0	84.3
80	106.8	99.5	98.0	98.0	90.0	99.0	100.5	101.8	100.3
100	88.3	83.0	82.3	81.3	81.5	82.5	82.5	84.3	83.3
125	86.0	85.0	80.3	80.5	86.0	84.8	80.5	83.3	82.8
160	97.3	96.5	88.0	89.0	100.0	98.3	90.5	96.5	95.5
200	87.8	81.3	79.8	85.3	84.8	83.5	82.8	84.8	86.0
250	86.8	81.3	82.0	85.0	79.8	80.3	79.0	86.0	89.8
315	91.0	86.3	87.5	85.5	84.5	86.0	85.5	85.3	85.5
400	91.8	87.0	88.0	88.8	88.5	88.5	87.8	88.5	89.8
500	93.0	87.0	86.0	90.0	86.3	90.3	88.8	89.5	90.3
630	94.0	88.0	86.5	91.5	90.3	91.3	90.0	91.8	92.0
800	92.8	86.0	84.8	86.3	86.8	87.0	86.8	87.0	88.3
1000	91.3	85.0	82.8	84.8	85.5	85.0	85.5	85.3	85.0
1250	88.8	81.3	81.0	84.0	84.3	84.3	84.3	84.0	84.3
1600	85.5	78.5	77.3	82.0	82.3	82.5	82.5	82.0	82.5
2000	82.5	76.0	75.8	77.3	77.0	77.0	77.8	77.3	77.5
2500	78.8	73.3	72.5	74.0	73.8	74.5	74.8	73.8	74.0
3150	76.3	70.8	70.8	71.8	71.8	72.0	72.3	71.5	72.3
4000	73.5	67.8	68.5	69.8	69.0	69.5	70.8	69.8	69.8
5000	70.8	66.3	67.5	67.8	67.5	67.8	68.5	68.0	68.3

NA Not Available

APPENDIX F

One-Third Octave Band Spectra for Interior Sound Pressures:
Flight 4, Interior Treated with Fiberglass.

TABLE F.1

ONE-THIRD OCTAVE BAND SOUND PRESSURE LEVELS, FLIGHT #4
CABIN MICROPHONE NUMBER 1

Band Center Frequency Hz	One-Third Octave Band Sound Pressure Level, dB re 20 micro Pa								
	Test Condition								
	1	2	3	4	5	6	7	8	9
25	97.5	97.0	101.5	102.3	NA	NA	NA	NA	102.3
32	85.3	83.0	85.0	88.3	NA	NA	NA	NA	88.8
40	74.0	73.5	69.3	70.0	NA	NA	NA	NA	69.5
50	74.5	76.0	77.5	74.5	NA	NA	NA	NA	74.8
63	89.5	91.8	95.3	93.3	NA	NA	NA	NA	93.0
80	105.3	107.0	110.3	109.5	NA	NA	NA	NA	110.0
100	87.8	88.0	90.8	90.5	NA	NA	NA	NA	91.0
125	85.8	86.5	88.0	87.0	NA	NA	NA	NA	86.0
160	101.8	101.0	102.3	101.5	NA	NA	NA	NA	101.5
200	89.0	88.0	87.0	87.8	NA	NA	NA	NA	88.5
250	91.5	90.3	88.8	89.8	NA	NA	NA	NA	89.5
315	85.3	85.8	84.8	84.3	NA	NA	NA	NA	83.3
400	83.5	84.3	86.5	86.0	NA	NA	NA	NA	85.5
500	87.5	87.5	88.0	88.0	NA	NA	NA	NA	88.5
630	85.3	85.5	87.3	86.8	NA	NA	NA	NA	86.8
800	82.0	82.8	84.8	84.8	NA	NA	NA	NA	82.5
1000	84.0	83.8	84.0	84.0	NA	NA	NA	NA	82.3
1250	81.3	81.0	79.3	79.8	NA	NA	NA	NA	78.3
1600	80.5	80.0	79.5	79.5	NA	NA	NA	NA	79.3
2000	79.0	77.5	78.0	78.8	NA	NA	NA	NA	76.8
2500	75.3	74.8	76.3	76.5	NA	NA	NA	NA	75.5
3150	70.0	70.3	72.5	72.0	NA	NA	NA	NA	72.0
4000	66.8	66.5	68.8	68.5	NA	NA	NA	NA	67.3
5000	64.3	63.8	66.8	67.0	NA	NA	NA	NA	66.0

NA Not Available

TABLE F.1 (CONTINUED)

ONE-THIRD OCTAVE BAND SOUND PRESSURE LEVELS. FLIGHT #4
CABIN MICROPHONE NUMBER 1

Band Center Frequency Hz	One-Third Octave Band Sound Pressure Level, dB re 20 micro Pa									
	Test Condition									
	10	11	12	13	14	15	16	17	18	
25	101.8	93.8	99.5	103.0	NA	NA	NA	106.0	104.5	
32	85.5	77.3	82.5	85.5	NA	NA	NA	92.3	88.0	
40	69.5	64.8	68.0	67.8	NA	NA	NA	71.8	69.3	
50	78.3	70.5	74.5	73.0	NA	NA	NA	71.8	73.3	
63	96.5	90.3	94.5	92.8	NA	NA	NA	89.5	91.5	
80	111.5	103.0	108.8	106.8	NA	NA	NA	105.3	106.3	
100	91.8	83.5	87.8	85.3	NA	NA	NA	86.8	86.5	
125	86.3	81.8	83.3	80.8	NA	NA	NA	80.3	80.3	
160	98.8	92.3	92.5	92.0	NA	NA	NA	94.5	94.0	
200	88.3	83.3	81.3	84.0	NA	NA	NA	85.5	84.8	
250	89.3	80.3	80.0	85.5	NA	NA	NA	87.8	86.0	
315	83.8	78.5	76.3	76.3	NA	NA	NA	80.0	80.8	
400	85.5	81.5	81.8	79.8	NA	NA	NA	82.3	81.3	
500	88.3	85.0	83.3	83.5	NA	NA	NA	85.5	85.5	
630	86.5	83.0	79.5	80.5	NA	NA	NA	79.0	80.3	
800	83.8	79.5	77.5	79.8	NA	NA	NA	81.3	80.3	
1000	82.8	77.3	77.3	77.0	NA	NA	NA	78.0	77.5	
1250	79.5	73.3	72.5	73.5	NA	NA	NA	74.3	74.3	
1600	79.8	73.5	71.3	72.8	NA	NA	NA	74.3	73.8	
2000	79.0	72.0	68.8	70.8	NA	NA	NA	72.0	72.0	
2500	76.5	69.3	68.0	68.0	NA	NA	NA	69.3	69.5	
3150	72.5	68.0	66.5	66.0	NA	NA	NA	67.0	66.3	
4000	68.5	65.0	64.5	62.3	NA	NA	NA	62.8	62.8	
5000	66.8	63.8	63.8	61.5	NA	NA	NA	62.3	62.0	

NA Not Available

TABLE F.2

ONE-THIRD OCTAVE BAND SOUND PRESSURE LEVELS. FLIGHT #4
CABIN MICROPHONE NUMBER 2

Band Center Frequency Hz	One-Third Octave Band Sound Pressure Level, dB re 20 micro Pa								
	Test Condition								
	1	2	3	4	5	6	7	8	9
25	84.0	83.8	88.0	89.0	NA	NA	NA	NA	88.5
32	73.8	72.3	71.3	74.5	NA	NA	NA	NA	75.0
40	72.5	72.8	68.8	68.0	NA	NA	NA	NA	67.0
50	84.3	83.3	83.8	85.8	NA	NA	NA	NA	84.5
63	93.0	94.5	98.0	96.8	NA	NA	NA	NA	96.0
80	108.3	109.5	112.5	112.0	NA	NA	NA	NA	112.0
100	88.3	88.8	91.8	91.5	NA	NA	NA	NA	92.0
125	89.0	90.0	89.3	89.5	NA	NA	NA	NA	88.0
160	102.5	101.3	97.8	100.0	NA	NA	NA	NA	97.5
200	86.0	84.5	83.8	84.8	NA	NA	NA	NA	84.0
250	84.8	83.5	82.5	84.0	NA	NA	NA	NA	83.5
315	80.5	79.5	78.5	78.0	NA	NA	NA	NA	76.5
400	76.3	76.0	81.3	82.5	NA	NA	NA	NA	82.0
500	74.8	75.3	79.5	79.3	NA	NA	NA	NA	81.8
630	73.0	72.8	76.3	77.3	NA	NA	NA	NA	76.0
800	72.5	71.5	74.0	74.3	NA	NA	NA	NA	73.8
1000	72.3	71.8	72.0	72.5	NA	NA	NA	NA	71.3
1250	69.3	69.8	68.8	68.8	NA	NA	NA	NA	67.8
1600	67.3	66.8	67.3	67.3	NA	NA	NA	NA	66.0
2000	64.8	65.0	65.0	64.5	NA	NA	NA	NA	64.5
2500	62.8	61.8	62.5	62.3	NA	NA	NA	NA	62.3
3150	60.0	60.0	61.5	61.8	NA	NA	NA	NA	61.0
4000	60.0	60.0	61.0	61.0	NA	NA	NA	NA	60.8
5000	60.0	60.0	60.3	60.5	NA	NA	NA	NA	60.0

NA Not Available

TABLE F.2 (CONTINUED)

ONE-THIRD OCTAVE BAND SOUND PRESSURE LEVELS, FLIGHT #4
CABIN MICROPHONE NUMBER 2

Band Center Frequency Hz	One-Third Octave Band Sound Pressure Level, dB re 20 micro Pa								
	10	11	12	13	14	15	16	17	18
25	88.0	79.8	86.0	88.5	NA	NA	NA	92.0	90.0
32	72.0	64.3	69.0	70.8	NA	NA	NA	78.0	73.5
40	68.3	65.0	66.0	64.3	NA	NA	NA	64.5	64.5
50	83.8	76.8	79.3	76.8	NA	NA	NA	77.5	77.8
63	98.8	95.3	96.3	94.5	NA	NA	NA	91.5	93.0
80	113.5	109.0	110.3	108.5	NA	NA	NA	107.3	108.3
100	92.0	86.8	88.3	86.5	NA	NA	NA	87.5	87.3
125	89.5	85.5	87.0	86.0	NA	NA	NA	86.5	86.0
160	98.0	92.8	95.5	96.0	NA	NA	NA	98.3	97.5
200	85.5	81.5	81.8	81.8	NA	NA	NA	82.8	81.8
250	87.3	79.5	85.3	84.8	NA	NA	NA	85.8	82.0
315	77.3	73.5	71.0	74.5	NA	NA	NA	74.3	79.8
400	82.0	75.8	73.3	75.0	NA	NA	NA	76.5	76.8
500	82.8	74.8	75.3	77.0	NA	NA	NA	80.5	80.0
630	75.0	73.0	67.3	71.5	NA	NA	NA	73.5	72.3
800	73.3	68.0	67.0	67.5	NA	NA	NA	70.0	69.5
1000	71.8	66.8	65.8	65.5	NA	NA	NA	66.3	66.8
1250	69.0	63.5	61.8	62.8	NA	NA	NA	64.3	63.5
1600	66.5	61.0	60.0	60.0	NA	NA	NA	60.8	60.5
2000	65.5	60.3	60.0	60.0	NA	NA	NA	60.0	60.0
2500	62.8	60.0	60.0	60.0	NA	NA	NA	60.0	60.0
3150	61.3	60.0	60.0	60.0	NA	NA	NA	60.0	60.0
4000	61.0	60.0	60.0	60.0	NA	NA	NA	60.0	60.0
5000	60.8	60.0	60.0	60.0	NA	NA	NA	60.0	60.0

NA Not Available

TABLE F.3

ONE-THIRD OCTAVE BAND SOUND PRESSURE LEVELS. FLIGHT #4
CABIN MICROPHONE NUMBER 3

Band Center Frequency Hz	One-Third Octave Band Sound Pressure Level, dB re 20 micro Pa								
	Test Condition								
	1	2	3	4	5	6	7	8	9
25	88.0	88.0	91.8	92.3	NA	NA	NA	NA	92.0
32	74.5	72.0	75.5	78.0	NA	NA	NA	NA	78.5
40	70.5	70.8	68.3	68.0	NA	NA	NA	NA	66.3
50	84.8	84.3	85.0	86.0	NA	NA	NA	NA	84.5
63	90.0	92.0	90.8	89.8	NA	NA	NA	NA	88.5
80	107.8	106.5	105.0	107.0	NA	NA	NA	NA	105.5
100	89.5	86.5	87.5	89.3	NA	NA	NA	NA	88.3
125	85.3	84.3	85.0	86.5	NA	NA	NA	NA	85.5
160	99.0	94.3	92.8	98.0	NA	NA	NA	NA	95.5
200	88.5	86.0	84.8	87.0	NA	NA	NA	NA	86.0
250	93.0	93.8	91.8	92.3	NA	NA	NA	NA	91.8
315	78.5	80.0	86.3	85.0	NA	NA	NA	NA	85.8
400	77.8	77.3	83.5	83.8	NA	NA	NA	NA	83.5
500	76.0	76.8	80.3	80.5	NA	NA	NA	NA	83.0
630	75.5	74.8	77.5	79.0	NA	NA	NA	NA	79.0
800	74.0	73.5	75.5	75.5	NA	NA	NA	NA	75.3
1000	74.8	74.0	74.0	74.0	NA	NA	NA	NA	73.3
1250	72.5	72.0	70.8	70.5	NA	NA	NA	NA	70.3
1600	70.8	70.8	67.5	67.8	NA	NA	NA	NA	67.3
2000	68.5	69.0	68.0	67.8	NA	NA	NA	NA	67.5
2500	65.0	66.0	63.5	64.0	NA	NA	NA	NA	64.0
3150	62.0	62.3	63.5	63.5	NA	NA	NA	NA	63.3
4000	63.8	63.5	64.3	64.3	NA	NA	NA	NA	64.0
5000	64.3	63.8	64.5	64.5	NA	NA	NA	NA	64.0

NA Not Available

TABLE F.3 (CONTINUED)

ONE-THIRD OCTAVE BAND SOUND PRESSURE LEVELS, FLIGHT #4
CABIN MICROPHONE NUMBER 3

Band Center Frequency Hz	One-Third Octave Band Sound Pressure Level, dB re 20 micro Pa								
	Test Condition								
	10	11	12	13	14	15	16	17	18
25	92.0	83.5	90.5	93.3	NA	NA	NA	96.5	95.0
32	76.0	68.0	73.0	75.8	NA	NA	NA	82.5	78.3
40	66.8	64.5	65.5	63.5	NA	NA	NA	65.8	64.5
50	83.8	75.0	77.8	74.8	NA	NA	NA	75.8	75.8
63	89.0	84.8	89.8	83.8	NA	NA	NA	84.8	79.3
80	102.8	97.5	103.5	96.8	NA	NA	NA	98.8	93.5
100	87.0	82.0	86.3	82.0	NA	NA	NA	83.3	82.5
125	85.8	83.8	86.0	84.0	NA	NA	NA	83.5	83.0
160	93.3	93.0	94.0	96.3	NA	NA	NA	95.8	94.5
200	85.5	84.5	80.0	81.5	NA	NA	NA	81.8	81.0
250	92.3	88.3	83.5	85.3	NA	NA	NA	87.0	84.8
315	86.5	82.5	79.5	81.3	NA	NA	NA	82.0	82.0
400	81.8	76.8	75.5	81.8	NA	NA	NA	80.3	81.3
500	80.8	76.0	73.8	84.3	NA	NA	NA	83.3	88.3
630	76.8	73.8	70.5	73.3	NA	NA	NA	73.3	77.0
800	75.5	70.3	68.8	70.8	NA	NA	NA	72.0	73.8
1000	73.8	69.8	69.0	68.8	NA	NA	NA	69.3	70.0
1250	70.8	66.8	66.3	67.0	NA	NA	NA	66.8	67.0
1600	68.0	64.0	63.0	63.5	NA	NA	NA	64.0	64.3
2000	67.8	65.0	63.8	63.8	NA	NA	NA	64.5	64.0
2500	64.0	61.5	60.5	61.0	NA	NA	NA	61.5	61.5
3150	64.0	61.5	61.3	61.0	NA	NA	NA	61.5	61.5
4000	64.3	62.8	62.3	62.8	NA	NA	NA	62.8	62.5
5000	64.3	64.0	63.8	63.0	NA	NA	NA	63.5	62.5

NA Not Available

TABLE F.4

ONE-THIRD OCTAVE BAND SOUND PRESSURE LEVELS. FLIGHT #4
CABIN MICROPHONE NUMBER 4

Band Center Frequency Hz	One-Third Octave Band Sound Pressure Level, dB re 20 micro Pa								
	Test Condition								
	1	2	3	4	5	6	7	8	9
25	95.0	94.8	99.5	99.8	NA	NA	NA	NA	99.8
32	81.5	79.8	82.8	86.5	NA	NA	NA	NA	86.8
40	68.8	69.0	69.0	70.0	NA	NA	NA	NA	69.5
50	77.0	78.3	79.3	79.5	NA	NA	NA	NA	78.8
63	94.8	97.0	98.3	98.0	NA	NA	NA	NA	97.0
80	111.8	111.8	113.0	114.3	NA	NA	NA	NA	113.5
100	92.5	89.8	91.5	94.0	NA	NA	NA	NA	93.5
125	85.3	86.3	88.0	87.5	NA	NA	NA	NA	86.0
160	93.0	94.3	99.8	99.5	NA	NA	NA	NA	99.3
200	80.5	80.3	84.3	83.5	NA	NA	NA	NA	83.5
250	83.3	84.0	82.3	81.8	NA	NA	NA	NA	80.8
315	80.8	79.0	82.5	83.3	NA	NA	NA	NA	82.5
400	77.3	76.5	79.0	80.8	NA	NA	NA	NA	78.8
500	76.3	76.3	80.3	80.5	NA	NA	NA	NA	80.0
630	77.0	76.8	80.0	81.0	NA	NA	NA	NA	80.8
800	74.8	74.5	77.8	77.3	NA	NA	NA	NA	77.5
1000	74.5	74.5	74.8	75.3	NA	NA	NA	NA	74.5
1250	74.8	74.5	71.8	71.8	NA	NA	NA	NA	71.0
1600	70.0	70.8	66.8	67.0	NA	NA	NA	NA	67.0
2000	67.0	67.0	64.3	64.8	NA	NA	NA	NA	64.8
2500	63.8	64.0	61.0	61.0	NA	NA	NA	NA	60.8
3150	59.0	60.0	60.5	61.0	NA	NA	NA	NA	60.3
4000	58.3	60.0	60.0	60.0	NA	NA	NA	NA	60.0
5000	57.8	60.0	60.0	60.0	NA	NA	NA	NA	60.0

NA Not Available

TABLE F.4 (CONTINUED)

ONE-THIRD OCTAVE BAND SOUND PRESSURE LEVELS. FLIGHT #4
CABIN MICROPHONE NUMBER 4

Band Center Frequency Hz	One-Third Octave Band Sound Pressure Level, dB re 20 micro Pa								
	Test Condition								
	10	11	12	13	14	15	16	17	18
25	99.5	91.0	97.5	100.5	NA	NA	NA	103.8	102.5
32	83.5	75.0	80.8	82.8	NA	NA	NA	90.0	85.5
40	68.8	66.0	68.0	66.5	NA	NA	NA	70.3	67.8
50	78.5	74.5	76.0	74.0	NA	NA	NA	73.5	71.8
63	97.8	95.5	96.3	94.3	NA	NA	NA	93.0	90.5
80	112.5	109.0	110.5	107.8	NA	NA	NA	108.0	105.5
100	91.3	86.3	88.3	85.5	NA	NA	NA	86.8	85.3
125	87.5	81.8	85.0	81.0	NA	NA	NA	81.3	81.5
160	98.5	86.0	96.0	91.8	NA	NA	NA	93.8	93.5
200	82.5	77.5	76.8	76.5	NA	NA	NA	77.0	78.5
250	82.0	75.0	69.5	75.5	NA	NA	NA	77.8	76.5
315	81.5	74.8	74.3	73.3	NA	NA	NA	74.5	76.0
400	80.0	77.8	75.3	76.8	NA	NA	NA	77.0	78.0
500	80.3	76.5	73.8	75.5	NA	NA	NA	75.5	76.5
630	80.8	79.0	71.8	76.5	NA	NA	NA	78.0	75.8
800	78.3	72.3	69.3	70.0	NA	NA	NA	72.0	71.5
1000	75.3	69.5	68.5	67.5	NA	NA	NA	69.0	68.5
1250	71.8	65.0	63.8	64.5	NA	NA	NA	65.5	65.5
1600	67.8	60.3	60.0	60.8	NA	NA	NA	62.0	61.5
2000	65.3	58.3	60.0	58.8	NA	NA	NA	60.0	59.5
2500	61.3	56.0	60.0	57.8	NA	NA	NA	56.8	56.8
3150	60.5	55.8	60.0	55.0	NA	NA	NA	56.0	55.5
4000	60.0	56.0	60.0	55.5	NA	NA	NA	56.3	55.8
5000	60.0	56.5	60.0	56.0	NA	NA	NA	56.5	56.3

NA Not Available

TABLE F.5

ONE-THIRD OCTAVE BAND SOUND PRESSURE LEVELS. FLIGHT #4
CABIN MICROPHONE NUMBER 5

Band Center Frequency Hz	One-Third Octave Band Sound Pressure Level, dB re 20 micro Pa								
	Test Condition								
	1	2	3	4	5	6	7	8	9
25	95.5	95.3	100.0	100.3	NA	NA	NA	NA	100.8
32	82.0	79.5	83.0	87.0	NA	NA	NA	NA	87.0
40	68.5	68.8	69.3	70.0	NA	NA	NA	NA	69.5
50	75.3	76.5	79.0	78.8	NA	NA	NA	NA	78.3
63	94.3	95.3	98.0	97.8	NA	NA	NA	NA	96.8
80	109.3	110.5	113.0	113.0	NA	NA	NA	NA	112.8
100	89.0	89.3	92.0	92.8	NA	NA	NA	NA	92.5
125	85.3	86.3	88.0	86.8	NA	NA	NA	NA	86.8
160	100.3	98.5	100.0	101.0	NA	NA	NA	NA	101.8
200	83.8	83.0	85.0	85.3	NA	NA	NA	NA	85.5
250	87.3	85.5	79.3	82.0	NA	NA	NA	NA	81.8
315	81.0	80.3	83.3	83.3	NA	NA	NA	NA	84.3
400	78.8	78.0	82.8	86.3	NA	NA	NA	NA	87.8
500	76.0	75.8	80.5	80.8	NA	NA	NA	NA	80.5
630	77.5	77.5	79.8	80.0	NA	NA	NA	NA	79.8
800	75.0	75.5	77.5	77.5	NA	NA	NA	NA	77.5
1000	75.3	74.8	74.3	74.8	NA	NA	NA	NA	74.5
1250	75.3	75.0	71.5	71.8	NA	NA	NA	NA	71.0
1600	71.3	70.8	67.3	67.5	NA	NA	NA	NA	67.0
2000	68.8	67.8	65.0	64.8	NA	NA	NA	NA	64.5
2500	66.5	66.3	60.8	61.5	NA	NA	NA	NA	61.5
3150	59.0	58.0	60.0	60.0	NA	NA	NA	NA	60.0
4000	59.3	58.8	60.0	60.3	NA	NA	NA	NA	60.0
5000	59.3	58.5	60.3	60.3	NA	NA	NA	NA	60.0

NA Not Available

TABLE F.5 (CONTINUED)

ONE-THIRD OCTAVE BAND SOUND PRESSURE LEVELS. FLIGHT #4
CABIN MICROPHONE NUMBER 5

Band Center Frequency Hz	One-Third Octave Band Sound Pressure Level, dB re 20 micro Pa								
	Test Condition								
	10	11	12	13	14	15	16	17	18
25	100.0	91.5	98.3	101.3	NA	NA	NA	104.5	102.8
32	83.5	75.8	81.0	83.3	NA	NA	NA	90.0	85.8
40	69.0	66.0	67.8	67.5	NA	NA	NA	70.5	68.0
50	78.3	75.0	75.8	74.8	NA	NA	NA	73.3	72.5
63	98.0	95.8	96.0	95.0	NA	NA	NA	93.0	91.5
80	113.3	109.3	110.3	109.0	NA	NA	NA	107.5	107.0
100	92.3	86.5	88.0	86.3	NA	NA	NA	86.5	86.5
125	87.8	83.8	84.3	83.8	NA	NA	NA	83.5	81.5
160	100.3	95.3	96.3	96.5	NA	NA	NA	97.3	95.5
200	84.3	80.5	78.5	80.8	NA	NA	NA	81.3	81.0
250	83.8	79.5	79.8	80.8	NA	NA	NA	82.3	82.3
315	85.0	76.8	77.0	80.3	NA	NA	NA	82.8	82.0
400	82.8	75.8	78.8	78.0	NA	NA	NA	79.5	79.0
500	80.5	75.8	75.3	74.0	NA	NA	NA	76.5	75.8
630	79.8	76.0	72.3	77.3	NA	NA	NA	78.3	76.0
800	77.5	71.5	70.0	70.8	NA	NA	NA	72.0	72.5
1000	75.0	68.5	67.0	67.8	NA	NA	NA	68.5	68.5
1250	71.3	64.8	64.5	65.5	NA	NA	NA	66.5	66.0
1600	67.8	60.5	60.3	61.8	NA	NA	NA	63.0	63.0
2000	65.3	59.5	60.0	60.0	NA	NA	NA	60.5	61.3
2500	61.5	56.3	60.0	56.0	NA	NA	NA	56.5	56.5
3150	60.5	56.0	60.0	55.8	NA	NA	NA	56.3	56.0
4000	60.0	57.0	60.0	56.8	NA	NA	NA	57.0	57.0
5000	60.0	58.5	60.0	57.8	NA	NA	NA	57.8	58.0

NA Not Available

TABLE F.6

ONE-THIRD OCTAVE BAND SOUND PRESSURE LEVELS, FLIGHT #4
CABIN MICROPHONE NUMBER 6

Band Center Frequency Hz	One-Third Octave Band Sound Pressure Level, dB re 20 micro Pa								
	Test Condition								
	1	2	3	4	5	6	7	8	9
25	86.5	86.5	90.0	91.0	NA	NA	NA	NA	91.0
32	73.3	70.8	73.5	77.3	NA	NA	NA	NA	77.5
40	69.8	69.8	67.0	66.5	NA	NA	NA	NA	65.0
50	82.5	81.5	82.5	83.5	NA	NA	NA	NA	82.3
63	85.3	85.3	86.5	86.0	NA	NA	NA	NA	85.0
80	100.3	101.3	102.5	101.5	NA	NA	NA	NA	100.8
100	83.0	83.8	84.8	84.8	NA	NA	NA	NA	84.0
125	89.0	91.0	91.8	90.5	NA	NA	NA	NA	90.8
160	105.5	105.0	106.3	107.3	NA	NA	NA	NA	107.3
200	89.8	90.8	89.3	89.5	NA	NA	NA	NA	88.8
250	97.5	96.3	93.0	94.5	NA	NA	NA	NA	92.0
315	88.0	86.5	85.5	90.0	NA	NA	NA	NA	89.0
400	77.5	77.0	85.5	88.8	NA	NA	NA	NA	88.5
500	77.0	76.8	81.0	84.0	NA	NA	NA	NA	86.3
630	73.8	74.0	77.3	77.0	NA	NA	NA	NA	77.0
800	74.0	73.0	75.3	75.5	NA	NA	NA	NA	75.0
1000	74.3	73.0	73.8	73.8	NA	NA	NA	NA	73.5
1250	74.5	73.3	69.8	70.5	NA	NA	NA	NA	69.0
1600	71.3	71.3	67.0	67.5	NA	NA	NA	NA	66.0
2000	69.3	70.0	65.0	65.3	NA	NA	NA	NA	65.0
2500	64.8	64.5	62.8	62.5	NA	NA	NA	NA	62.5
3150	59.3	59.3	60.8	61.0	NA	NA	NA	NA	61.0
4000	59.0	58.8	60.0	61.3	NA	NA	NA	NA	60.8
5000	59.0	58.5	60.0	60.3	NA	NA	NA	NA	60.0

NA Not Available

TABLE F.6 (CONTINUED)

ONE-THIRD OCTAVE BAND SOUND PRESSURE LEVELS, FLIGHT #4
CABIN MICROPHONE NUMBER 6

Band Center Frequency Hz	One-Third Octave Band Sound Pressure Level, dB re 20 micro Pa								
	Test Condition								
	10	11	12	13	14	15	16	17	18
25	90.5	82.3	88.8	92.3	NA	NA	NA	95.5	93.5
32	74.0	67.0	72.0	74.8	NA	NA	NA	81.5	77.3
40	65.8	63.8	64.0	63.0	NA	NA	NA	64.5	63.5
50	81.5	73.3	76.8	72.0	NA	NA	NA	75.3	73.0
63	85.3	82.5	84.8	83.8	NA	NA	NA	81.0	79.8
80	101.0	95.8	98.5	97.8	NA	NA	NA	94.8	96.0
100	84.0	80.3	80.5	79.5	NA	NA	NA	78.5	79.5
125	92.3	86.0	90.0	88.0	NA	NA	NA	87.0	88.0
160	106.8	97.5	103.5	101.3	NA	NA	NA	103.0	102.5
200	88.3	81.0	83.3	84.0	NA	NA	NA	84.8	84.8
250	90.5	81.3	86.3	88.0	NA	NA	NA	88.8	88.5
315	86.5	76.8	83.8	82.0	NA	NA	NA	86.5	82.5
400	86.0	76.3	81.0	83.0	NA	NA	NA	85.8	84.3
500	82.8	75.3	78.8	80.8	NA	NA	NA	79.5	83.5
630	77.0	71.5	69.8	73.5	NA	NA	NA	75.0	74.0
800	75.5	69.0	67.8	69.0	NA	NA	NA	70.0	70.0
1000	74.0	68.0	67.3	67.0	NA	NA	NA	68.0	67.8
1250	70.0	64.5	63.0	63.8	NA	NA	NA	64.3	64.5
1500	67.0	61.5	60.8	61.0	NA	NA	NA	62.0	61.5
2000	65.8	61.0	60.3	59.5	NA	NA	NA	61.0	60.0
2500	62.8	58.0	57.8	57.3	NA	NA	NA	57.8	58.0
3150	61.3	56.8	56.3	56.5	NA	NA	NA	57.8	57.0
4000	60.8	57.0	56.8	56.8	NA	NA	NA	57.3	57.0
5000	60.5	57.0	57.0	56.3	NA	NA	NA	56.8	56.5

NA Not Available

APPENDIX G

Effect of Cabin Pressurization on Cabin Sound Pressure Levels
(Harmonics and One-Third Octave Bands).

TABLE G.1

CABIN MICROPHONE NUMBER 3 : EFFECT OF PRESSURIZATION

Test Condition	Flight Number	Harmonic Level, dB re 20 micro Pa									
		1	2	3	4	5	6	7	8	9	10
STARBOARD ENGINE COMPONENTS											
Cond3 - Cond2	3	9.6	-5.2	-3.5	3.3	2.5	18.7	-2.5			
Cond4 - Cond1	3	6.7	-1.2	-5.5	-10.9	5.1	0.9				
Cond3 - Cond2	4	-4.7	4.7	-3.4	6.5	11.5		3.6	7.2	3.3	
Cond4 - Cond1	4	6.0	-0.1	-3.6	11.0	5.8	7.4	4.4	5.1		
PORT ENGINE COMPONENTS											
Cond3 - Cond2	3	-4.5	8.5	0.1	11.1	3.8	-2.9				
Cond4 - Cond1	3	-12.4	-7.8	4.4	3.6	3.2	10.9	1.1			
Cond3 - Cond2	4	-1.1	-7.8	0.8	12.8	5.7	5.6				
Cond4 - Cond1	4	-0.7	-2.7	3.8	8.7	13.0	9.3	2.0		2.6	

CABIN MICROPHONE NUMBER 6 : EFFECT OF PRESSURIZATION

Test Condition	Flight Number	Harmonic Level, dB re 20 micro Pa									
		1.0	2.0	3.0	4.0	5.0	6.0	7.0	8.0	9.0	10.0
STARBOARD ENGINE COMPONENTS											
Cond3 - Cond2	3	-0.8	3.4	-12.1	10.7	-3.2					
Cond4 - Cond1	3	0.2	6.8	-6.9	-3.3	7.8		4.2			
Cond3 - Cond2	4	0.4	5.0	-0.7	2.3	18.5	2.4	7.8	2.3		
Cond4 - Cond1	4	0.4	1.6	2.8	5.9	14.5	7.5	3.3	1.8		
PORT ENGINE COMPONENTS											
Cond3 - Cond2	3	0.7	-1.7	-4.3	-8.4	7.5	4.2	3.1			
Cond4 - Cond1	3	2.2	0.2	-2.0	6.7	6.8	12.3	3.2			
Cond3 - Cond2	4	2.2	0.3	-3.4	-1.7	18.6	4.5		4.9		
Cond4 - Cond1	4	2.4	0.7	-2.7	1.5	21.0	11.1	10.9	14.3	2.1	

TABLE G.2

ONE-THIRD OCTAVE BAND SOUND PRESSURE LEVELS. FLIGHTS 3 AND 4.
EFFECT OF PRESSURIZATION

One-Third Octave Band Center Frequency Hz	Change in Sound Level, dB							
	Cabin Microphone No 3				Cabin Microphone No 6			
	Flight #3		Flight #4		Flight #3		Flight #4	
	Cond 3 -Cond 2	Cond 4 -Cond 1	Cond 3 -Cond 2	Cond 4 -Cond 1	Cond 3 -Cond 2	Cond 4 -Cond 1	Cond 3 -Cond 2	Cond 4 -Cond 1
25	2.0	0.5	3.8	4.3	3.0	2.5	3.5	4.5
32	-4.0	-3.5	3.5	3.5	-6.0	-4.3	2.7	4.0
40	-3.7	-3.0	-2.5	-2.5	-3.0	-1.8	-2.8	-3.3
50	-2.5	-1.5	0.7	1.2	0.0	1.8	1.0	1.0
63	-3.2	-2.8	-1.2	-0.2	0.3	1.8	1.2	0.7
80	-3.3	-4.5	-1.5	-0.8	0.0	2.0	1.2	1.2
100	0.5	-2.0	1.0	-0.2	0.3	2.0	1.0	1.8
125	2.3	0.8	0.7	1.2	-0.3	0.3	0.8	1.5
160	2.0	-1.5	-1.5	-1.0	1.8	1.5	1.3	1.8
200	-1.7	-3.0	-1.2	-1.5	-1.8	-3.0	-1.5	-0.3
250	-1.3	-0.3	-2.0	-0.7	-6.3	-2.5	-3.3	-3.0
315	0.7	-1.5	6.3	6.5	-1.0	1.5	-1.0	2.0
400	1.8	3.5	6.2	6.0	2.3	3.8	8.5	11.3
500	5.2	5.0	3.5	4.5	3.3	3.3	4.2	7.0
630	2.3	0.7	2.7	3.5	1.5	2.3	3.3	3.2
800	1.5	1.7	2.0	1.5	2.0	2.3	2.3	1.5
1000	1.5	2.5	0.0	-0.8	1.5	1.8	0.8	-0.5
1250	0.5	0.8	-1.2	-2.0	-0.5	0.8	-3.5	-4.0
1600	-0.7	0.3	-3.3	-3.0	-1.3	0.5	-4.3	-3.8
2000	-1.2	0.2	-1.0	-0.7	-0.8	-0.5	-5.0	-4.0
2500	-0.5	0.5	-2.5	-1.0	-1.3	0.0	-1.7	-2.3
3150	1.7	2.5	1.2	1.5	1.3	2.3	1.5	1.7
4000	1.5	2.3	0.8	0.5	1.5	2.3	1.2	2.3
5000	2.0	2.2	0.7	0.2	1.5	2.3	1.5	1.3

APPENDIX H

Noise Reduction for Untreated Cabin (Difference between Exterior and Interior Harmonics and One-Third Octave Band Sound Pressure Levels).

TABLE H.1

NOISE REDUCTION: EXTERIOR STARBOARD MIC SPL - CABIN MIC #3 SPL
(STARBOARD PROPELLER COMPONENT)

Test Condition	Flight Number	RPM	BPF Hz	Harmonic Level dB re 20 micro Pa																
				1	2	3	4	5	6	7	8	9	10							
1	Flight	1520.0	76.0	37.8	28.8	21.2	28.6	25.2	31.8											
2	3	1572.5	78.6	43.0	31.4	26.0	29.4	26.4	40.1	37.3										
3		1570.0	78.5	32.5	36.7	29.1	30.1	29.3	24.3	34.0	27.3									
4		1520.0	76.0	30.1	29.4	26.1	40.3	23.1	33.1	32.7										
9		1520.0	76.0	27.7	28.6	28.4	38.3	30.5	34.9											
10		1572.5	78.6	26.7	29.0	30.2	33.7	37.4	30.6	25.9										
11		1515.0	75.8	28.8	32.3	30.1	33.6	30.1	27.0	30.0	28.6	32.0	29.7							
17		1517.5	75.9	30.6	34.5	41.2	40.4	32.0	18.4	26.2	35.9	36.7								
18		1570.0	78.5	27.0	32.4	36.9	42.1	32.2	23.5	23.1	23.9	28.3	28.5							

TABLE H.2

NOISE REDUCTION : EXTERIOR PORT MICROPHONE SPL - CABIN MIC #6 SPL
(PORT PROPELLER COMPONENT)

Test Condition	Flight Number	RPM	BPF Hz	Harmonic Level, dB re 20 micro Pa																
				1	2	3	4	5	6	7	8	9	10							
1	Flight	1572.5	78.6	21.7	31.8	39.4	40.3	34.4	46.4	39.5										
2	3	1525.0	76.3	26.4	34.6	41.8	37.6	41.7	40.2	35.4										
3		1525.0	76.3	24.7	34.8	44.5	44.2	32.2	33.9	30.4	32.6									
4		1572.5	78.6	18.8	31.2	40.0	31.8	26.6	32.8	35.3	35.6									
9		1572.5	78.6	19.3	27.4	38.8	33.3	26.9	35.9	35.2	34.4	33.9								
10		1525.0	76.3	26.4	31.5	43.6	33.1	30.7	38.4	34.3										
12		1520.0	76.0	28.3	38.8	40.0	30.4	26.6	28.3	32.1	23.6	21.9	26.0							
17		1570.0	78.5	21.7	30.8	38.9	35.7	31.3	30.1	32.1	34.5	31.9								
18		1520.0	76.0	27.4	30.4	37.5	35.4	33.7	24.0	29.2	34.9									

TABLE H.3

ONE-THIRD OCTAVE BAND SOUND PRESSURE LEVELS, FLIGHT #3
 EXTERIOR STARBOARD MICROPHONE - CABIN MICROPHONE #3

Band Center Frequency Hz	Change in One-Third Octave Band Sound Pressure Level, dB								
	Test Condition								
	1	2	3	4	5	6	7	8	9
25	32.5	32.5	24.7	26.8	21.5	23.0	25.5	25.5	22.7
32	33.7	35.3	33.0	32.5	31.5	32.2	34.3	27.5	30.8
40	42.2	42.3	40.5	40.5	40.0	39.5	40.5	32.8	40.5
50	29.5	31.8	28.8	26.0	28.0	28.0	29.8	27.7	28.2
63	27.0	24.5	25.2	28.3	26.8	21.5	25.7	30.3	26.7
80	22.8	25.2	27.5	26.3	28.0	21.0	26.5	34.3	27.2
100	25.0	29.8	26.3	24.0	24.5	22.3	24.0	24.2	24.0
125	28.3	28.8	23.5	25.7	24.2	22.0	26.0	22.3	24.5
160	28.0	30.2	27.7	29.0	25.2	22.2	31.0	21.2	25.7
200	23.0	24.5	23.2	23.7	27.3	24.8	24.7	24.0	24.5
250	21.7	23.7	24.3	20.5	31.8	25.3	26.0	25.2	22.2
315	28.0	29.0	27.8	29.2	28.7	27.2	26.5	29.0	28.2
400	28.7	30.8	26.5	23.5	24.0	25.2	26.0	25.0	24.8
500	30.0	32.0	22.8	22.3	22.0	23.5	22.8	22.5	22.7
630	26.5	29.0	22.0	22.3	21.2	19.2	19.0	20.5	20.7
800	29.2	31.2	24.7	24.0	23.0	23.3	23.0	23.0	23.3
1000	31.5	33.0	26.0	25.3	24.0	23.7	24.0	24.3	24.0
1250	33.3	34.5	29.0	28.7	27.8	27.2	27.5	27.2	26.7
1600	34.8	35.3	31.7	30.5	29.5	29.3	29.3	29.3	29.0
2000	36.7	37.3	34.2	33.0	31.8	31.0	31.2	31.5	31.3
2500	39.0	39.5	35.7	35.3	33.7	33.8	33.5	33.7	33.3
3150	42.7	43.5	38.0	37.2	35.5	36.2	35.5	36.0	35.2
4000	42.3	43.3	38.8	38.0	37.3	38.0	36.8	37.5	36.7
5000	42.2	44.0	38.5	38.8	36.8	37.7	37.0	38.3	37.5

TABLE H.3 (CONTINUED)

ONE-THIRD OCTAVE BAND SOUND PRESSURE LEVELS, FLIGHT #3
 EXTERIOR STARBOARD MICROPHONE - CABIN MICROPHONE #3

Band Center Frequency Hz	Change in One-Third Octave Band Sound Pressure Level, dB								
	Test Condition								
	10	11	12	13	14	15	16	17	18
25	24.5	27.5	19.3	13.3	22.7	14.5	15.5	12.7	15.5
32	32.2	29.3	28.0	26.5	26.5	27.5	27.0	25.2	28.0
40	39.5	48.5	37.0	36.5	36.7	35.8	36.5	36.0	36.3
50	28.7	28.5	26.0	29.2	29.2	28.3	28.5	27.5	28.3
63	23.3	27.8	15.3	28.0	28.0	22.2	26.5	27.8	22.2
80	24.7	28.0	9.5	28.8	29.0	22.0	26.8	27.0	24.3
100	25.5	24.2	21.5	24.3	23.5	22.5	23.7	23.3	23.7
125	22.5	27.5	18.8	25.8	25.7	23.8	27.2	27.2	23.5
160	24.5	32.5	10.7	28.0	28.7	24.5	32.5	28.0	28.0
200	24.2	29.5	23.3	30.7	28.7	28.2	29.5	30.5	27.8
250	27.3	30.3	19.5	36.2	32.5	31.7	32.5	35.8	34.0
315	28.3	31.3	26.3	33.5	29.7	30.5	32.3	31.5	33.0
400	26.7	27.8	24.0	26.0	26.0	26.5	27.5	24.5	29.3
500	23.0	23.8	22.7	19.0	19.5	19.2	19.8	17.0	21.5
630	20.5	20.5	20.5	20.0	20.5	21.0	21.7	21.5	21.0
800	23.5	24.0	24.7	22.5	22.5	22.3	21.8	22.5	23.7
1000	24.0	26.0	26.5	23.5	23.8	23.7	23.8	23.2	24.7
1250	27.0	29.5	30.2	24.5	24.2	23.5	24.0	24.3	24.7
1600	29.8	31.2	31.7	26.2	25.8	26.0	26.5	26.7	27.3
2000	31.5	33.3	31.7	29.8	30.5	29.7	29.5	30.7	31.0
2500	33.8	33.5	34.5	31.5	33.0	32.3	32.5	32.2	32.5
3150	35.5	36.8	36.5	34.0	35.8	34.5	33.5	34.3	34.3
4000	36.7	37.7	38.0	35.3	36.5	35.8	34.8	35.2	34.7
5000	37.2	37.5	36.3	35.0	36.8	35.8	34.5	35.0	35.8

TABLE H.4

ONE-THIRD OCTAVE BAND SOUND PRESSURE LEVELS, FLIGHT #3
 EXTERIOR PORT MICROPHONE - CABIN MICROPHONE #6

Band Center Frequency Hz	Change in One-Third Octave Band Sound Pressure Level, dB								
	Test Condition								
	1	2	3	4	5	6	7	8	9
25	15.8	14.3	9.0	11.0	5.8	5.8	6.0	7.8	5.5
32	15.6	15.3	18.5	16.8	15.8	15.6	16.3	16.3	15.3
40	30.5	30.3	30.8	30.3	30.0	29.8	30.0	30.1	29.8
50	33.5	33.3	31.3	29.8	30.0	30.3	28.1	29.3	29.6
63	21.5	24.8	23.8	19.3	24.8	32.0	21.5	22.8	19.3
80	21.3	23.3	22.8	19.0	24.6	32.8	21.0	23.0	19.0
100	23.3	24.3	22.3	20.3	23.5	25.8	21.5	22.5	20.3
125	27.8	29.1	27.5	25.8	25.8	31.1	27.1	25.8	25.3
160	31.1	30.6	27.8	28.8	26.0	38.6	28.3	26.8	27.0
200	29.3	30.5	30.8	31.5	31.6	33.8	32.8	31.3	29.8
250	35.8	33.8	38.3	37.3	42.3	40.3	41.8	39.6	37.8
315	32.0	31.1	30.3	29.5	29.8	31.0	31.8	30.3	31.8
400	28.5	27.8	23.5	23.3	25.5	26.3	25.8	25.3	25.6
500	28.5	27.8	22.3	24.3	23.6	23.3	23.8	23.6	25.3
630	23.3	22.3	18.5	19.5	19.5	20.0	19.6	20.1	20.3
800	24.6	24.6	20.1	20.8	20.1	20.3	20.3	19.5	20.6
1000	25.3	26.1	22.3	21.8	20.8	20.8	21.0	20.8	20.6
1250	26.0	26.8	25.0	23.8	23.5	23.3	22.8	23.8	23.3
1600	29.0	28.8	28.0	27.3	26.3	25.8	25.3	26.0	25.8
2000	31.3	31.8	30.8	30.8	29.5	28.8	28.5	28.8	28.8
2500	34.5	35.1	34.3	33.5	32.1	32.3	31.8	31.5	31.8
3150	39.3	39.5	36.6	36.6	35.6	35.3	35.1	35.0	36.0
4000	41.5	42.0	39.3	39.1	38.0	37.8	37.3	37.8	38.1
5000	42.6	43.3	41.1	40.0	39.5	40.3	38.5	39.5	39.3

TABLE H.4 (CONTINUED)

ONE-THIRD OCTAVE BAND SOUND PRESSURE LEVELS, FLIGHT #3
 EXTERIOR PORT MICROPHONE - CABIN MICROPHONE #6

Band Center Frequency Hz	Change in One-Third Octave Band Sound Pressure Level, dB								
	Test Condition								
	10	11	12	13	14	15	16	17	18
25	6.8	10.5	6.8	-2.0	-1.7	-0.8	0.8	-2.2	0.5
32	15.5	11.0	12.5	10.8	9.5	11.0	12.3	9.5	12.0
40	29.8	26.8	26.6	25.8	26.0	25.3	25.8	25.6	25.8
50	29.6	27.8	31.8	31.3	34.0	31.5	30.8	30.8	30.6
63	24.3	14.3	29.6	27.6	33.8	24.8	25.3	22.5	26.3
80	22.6	10.3	29.5	27.5	34.5	24.3	25.3	22.8	24.3
100	21.6	19.0	24.8	23.8	23.3	21.8	23.3	22.6	21.6
125	28.3	19.5	31.3	29.3	22.5	25.6	29.8	24.1	27.1
160	31.1	13.0	37.3	35.0	21.8	26.1	33.5	27.5	27.8
200	30.8	23.6	35.3	29.1	29.3	30.5	30.8	28.1	29.0
250	37.8	24.6	38.0	35.5	40.3	40.1	41.3	36.8	30.8
315	29.8	20.3	29.3	30.0	32.8	32.3	30.8	33.6	31.8
400	25.8	19.8	25.0	24.6	26.5	26.5	27.1	27.5	25.1
500	23.3	21.0	23.5	21.8	24.8	23.6	24.8	25.0	22.6
630	19.3	19.8	21.3	17.8	19.6	19.3	19.8	19.8	17.3
800	19.6	22.3	23.6	21.8	22.3	22.3	22.1	23.3	20.3
1000	21.3	23.5	25.3	23.3	23.0	23.5	23.0	24.2	23.0
1250	22.8	27.6	27.3	23.8	23.8	24.3	23.8	24.5	24.1
1600	26.5	30.8	30.6	25.8	26.1	26.0	25.5	26.0	26.0
2000	29.0	32.3	32.1	30.1	31.0	31.5	30.3	30.3	30.5
2500	32.3	35.1	35.0	33.3	33.8	33.5	32.6	33.8	33.5
3150	34.3	37.6	37.1	35.8	36.1	35.8	35.3	36.0	35.6
4000	37.0	40.3	38.8	37.3	38.3	37.8	36.8	37.1	37.8
5000	40.1	41.3	38.5	39.1	39.8	39.3	38.8	38.5	39.1

APPENDIX I

Noise Reduction for Treated Cabin (Difference Between Exterior and Interior Harmonics and One-Third Octave Band Sound Pressure Levels).

TABLE 1.1

NOISE REDUCTION : EXTERIOR STARBOARD MIC SPL - CABIN MIC #3 SPL
(STARBOARD PROPELLER COMPONENT)

Test Condition	Flight Number	RPM	BPF Hz	Harmonic Level, dB re 20 micro Pa													
				1	2	3	4	5	6	7	8	9	10				
1	Flight	1520.0	76.0	38.9	34.3	27.8	45.6	38.3	47.9	43.0	49.3						
2	4	1570.0	78.5	44.8	40.0	26.8	36.9	37.8		49.1	56.2	54.8					
3		1572.5	78.6	49.0	35.6	31.9	34.8	33.1	35.4	40.3	39.7	38.9					
4		1517.5	75.9	31.8	33.4	31.1	34.9	33.8	41.6	37.3	41.3						
9		1530.0	76.5	28.6	31.5	30.1	35.1	37.1	34.9	35.6	44.6						
10		1572.5	78.6	36.7	38.8	32.4	36.8	37.0	37.1	38.4	40.6	37.1					
11		1515.0	75.8	31.0	31.8	32.9	35.1	38.8	33.0	40.6	40.2	40.2	39.6				
17		1517.5	75.9	28.0	31.4	37.9	38.9	44.5	27.9	48.3	44.2	42.5	35.4				
18		1572.5	78.6	35.5	34.6	42.2	40.0	42.6	27.4	44.3	36.2	37.0	38.8				

TABLE 1.2

NOISE REDUCTION : EXTERIOR PORT MICROPHONE SPL - CABIN MIC #6 SPL
(PORT PROPELLER COMPONENT)

Test Condition	Flight Number	RPM	BPF Hz	Harmonic Level, dB re 20 micro Pa													
				1	2	3	4	5	6	7	8	9	10				
1	Flight	1575.0	78.8	36.9	27.4	33.6	38.4	55.9	48.0	57.7	61.8	46.6					
2	4	1525.0	76.3	37.2	28.0	33.1	39.5	53.8	45.1		57.0						48.2
3		1527.5	76.4	33.3	26.4	34.8	39.2	33.3	38.2	45.3	50.4						
4		1572.5	78.6	33.1	25.4	34.7	34.1	32.7	35.3	44.5	45.3	42.9	51.0				
9		1575.0	78.8	34.4	23.8	37.5	36.1	33.4	33.0	45.7	46.5	42.5	52.2				
10		1527.5	76.4	33.9	25.5	37.5	38.9	36.1	37.1	42.4	44.9		47.2				
12		1520.0	76.0	30.7	23.8	36.1	35.1	33.7	29.4	38.5	40.9	42.4	39.7				
17		1570.0	78.5	36.5	24.3	37.0	35.8	33.6	41.6	47.4	48.2	45.0	46.9				
18		1517.5	75.9	36.6	24.6	34.7	38.5	35.2	37.7	40.0	54.2		44.3				

TABLE I.3

ONE-THIRD OCTAVE BAND SOUND PRESSURE LEVELS. FLIGHT #4
 EXTERIOR STARBOARD MICROPHONE - CABIN MICROPHONE #3

Band Center Frequency Hz	Change in One-Third Octave Band Sound Pressure Level, dB								
	Test Condition								
	1	2	3	4	5	6	7	8	9
25	19.0	19.5	11.0	9.7					8.0
32	32.5	36.5	25.8	23.8					21.5
40	38.0	39.0	35.7	35.5					35.5
50	24.5	26.7	20.3	19.8					19.0
63	27.0	22.5	21.5	25.5					25.3
80	22.2	22.8	23.8	21.8					22.3
100	25.0	39.3	25.0	21.5					21.5
125	31.2	31.7	27.8	27.8					27.3
160	28.0	32.7	34.2	28.0					30.3
200	30.0	31.5	30.2	29.5					29.8
250	28.5	28.7	30.7	28.5					29.7
315	41.0	39.8	33.0	33.3					32.7
400	40.7	42.2	33.8	32.7					32.8
500	43.0	43.7	36.5	35.5					32.0
630	43.5	45.7	38.3	36.5					35.0
800	45.0	47.8	40.0	40.0					38.5
1000	44.7	47.3	41.8	41.8					40.7
1250	46.5	48.8	45.2	45.0					43.2
1600	47.7	49.7	48.3	47.0					46.2
2000	50.0	50.8	47.8	47.2					45.8
2500	52.8	53.0	51.5	50.8					48.5
3150	54.8	56.2	50.0	51.0					49.0
4000	52.0	52.8	48.7	49.0					47.0
5000	49.5	52.0	47.5	46.5					45.8

TABLE I.3 (CONTINUED)

ONE-THIRD OCTAVE BAND SOUND PRESSURE LEVELS. FLIGHT #4
 EXTERIOR STARBOARD MICROPHONE - CABIN MICROPHONE #3

Band Center Frequency Hz	Change in One-Third Octave Band Sound Pressure Level, dB								
	Test Condition								
	10	11	12	13	14	15	16	17	18
25	9.0	14.3	2.5	2.0				-2.7	-0.2
32	25.3	29.3	22.3	19.0				12.8	16.5
40	36.2	34.0	31.5	33.0				31.2	32.5
50	20.5	26.5	22.0	24.0				23.0	23.2
63	22.3	30.2	12.5	28.5				26.7	29.0
80	25.2	31.0	7.5	29.0				26.2	31.8
100	24.5	26.5	18.0	24.0				22.0	25.5
125	26.0	29.2	20.3	27.3				27.3	25.3
160	33.5	32.5	13.3	28.2				28.2	30.5
200	29.3	32.0	25.8	34.5				33.5	31.5
250	30.7	32.7	22.5	35.7				33.3	37.7
315	33.3	34.5	27.0	37.2				36.0	38.0
400	35.7	37.0	31.3	34.0				35.5	36.7
500	35.7	35.0	34.2	29.2				30.5	28.7
630	37.7	36.7	37.3	37.0				36.5	35.5
800	39.5	39.5	39.7	36.5				35.8	36.7
1000	40.5	40.5	40.0	38.7				38.5	38.5
1250	44.0	42.5	43.0	39.8				40.0	40.8
1600	46.0	45.8	45.8	43.3				42.8	43.2
2000	46.0	43.8	45.0	42.5				42.3	43.3
2500	49.3	47.0	48.3	45.8				45.3	45.5
3150	48.3	47.0	47.5	45.3				44.8	45.0
4000	47.7	45.2	45.5	43.2				43.2	44.0
5000	47.0	41.8	43.0	42.0				41.3	42.5

TABLE 1.4

ONE-THIRD OCTAVE BAND SOUND PRESSURE LEVELS. FLIGHT #4
 EXTERIOR PORT MICROPHONE - CABIN MICROPHONE #6

Band Center Frequency Hz	Change in One-Third Octave Band Sound Pressure Level, dB								
	Test Condition								
	1	2	3	4	5	6	7	8	9
25	18.3	17.8	12.0	11.5	0.0	0.0	0.0	0.0	9.5
32	32.7	34.0	28.0	25.0	0.0	0.0	0.0	0.0	23.3
40	37.5	37.5	37.0	37.3	0.0	0.0	0.0	0.0	37.5
50	28.5	29.5	26.0	25.0	0.0	0.0	0.0	0.0	24.7
63	31.7	35.0	32.0	29.3	0.0	0.0	0.0	0.0	29.0
80	34.0	33.0	30.0	31.0	0.0	0.0	0.0	0.0	31.0
100	34.5	32.2	29.0	30.5	0.0	0.0	0.0	0.0	30.0
125	29.5	29.5	26.2	25.5	0.0	0.0	0.0	0.0	24.0
160	28.5	28.5	25.7	24.7	0.0	0.0	0.0	0.0	24.5
200	32.5	33.2	32.7	30.5	0.0	0.0	0.0	0.0	30.7
250	33.8	33.5	35.3	35.0	0.0	0.0	0.0	0.0	37.0
315	39.3	39.5	38.8	35.3	0.0	0.0	0.0	0.0	36.3
400	46.8	46.0	35.3	33.2	0.0	0.0	0.0	0.0	33.5
500	46.5	45.5	38.8	37.3	0.0	0.0	0.0	0.0	34.5
630	46.2	45.5	40.0	41.0	0.0	0.0	0.0	0.0	40.0
800	45.8	45.8	41.5	41.5	0.0	0.0	0.0	0.0	41.0
1000	44.7	46.5	43.0	43.0	0.0	0.0	0.0	0.0	41.8
1250	44.3	45.7	46.5	45.3	0.0	0.0	0.0	0.0	45.5
1600	47.5	47.5	49.0	48.5	0.0	0.0	0.0	0.0	48.5
2000	49.2	48.8	51.0	50.5	0.0	0.0	0.0	0.0	49.5
2500	53.2	53.5	52.7	53.3	0.0	0.0	0.0	0.0	51.5
3150	58.2	58.0	54.7	54.8	0.0	0.0	0.0	0.0	53.0
4000	58.5	58.2	55.8	54.2	0.0	0.0	0.0	0.0	53.2
5000	57.5	57.3	54.3	54.2	0.0	0.0	0.0	0.0	53.0

NA Not Available

TABLE 1.4 (CONTINUED)

ONE-THIRD OCTAVE BAND SOUND PRESSURE LEVELS. FLIGHT #4
 EXTERIOR PORT MICROPHONE - CABIN MICROPHONE #6

Band Center Frequency Hz	Change in One-Third Octave Band Sound Pressure Level, dB								
	Test Condition								
	10	11	12	13	14	15	16	17	18
25	10.3	11.7	7.0	1.5				-0.7	1.5
32	26.3	29.3	24.3	20.2				13.5	17.2
40	37.0	35.0	35.0	33.5				32.0	33.3
50	25.3	26.7	25.5	28.0				25.7	27.8
63	32.7	20.3	30.7	29.0				28.5	32.7
80	31.0	15.5	31.0	28.5				31.7	30.5
100	28.3	25.0	28.8	27.0				30.5	27.3
125	25.2	21.0	24.0	24.0				23.5	24.5
160	24.5	14.8	24.0	24.2				24.0	23.5
200	33.7	26.8	34.0	32.8				30.7	33.0
250	37.5	27.7	36.7	34.3				37.0	35.0
315	37.5	32.0	35.5	36.3				35.0	37.0
400	35.5	33.5	34.0	33.0				33.2	33.2
500	37.2	35.2	33.7	33.2				38.8	32.0
630	39.8	39.0	40.0	37.5				39.5	38.3
800	40.5	42.5	42.5	41.5				43.3	40.5
1000	41.3	43.8	43.7	43.3				43.0	42.7
1250	44.3	47.5	47.3	46.0				46.7	46.3
1600	47.8	50.5	50.0	48.8				48.5	49.0
2000	48.7	50.5	50.0	50.3				49.5	50.3
2500	51.2	53.5	52.0	52.2				52.5	52.5
3150	53.2	54.7	53.5	53.0				52.5	53.3
4000	53.5	54.0	53.0	53.0				53.2	53.0
5000	53.3	53.3	52.0	52.5				52.7	52.8

APPENDIX J

Insertion Loss Provided by Treatment (Differences in Harmonic and One-Third Octave Band Sound Pressure Levels for Flights 3 and 4; No Adjustments for Changes in Exterior Sound Pressure Level).

TABLE J.1

INSERTION LOSS AT PROPELLER HARMONICS

CABIN MICROPHONE NUMBER 3 : STARBOARD ENGINE COMPONENTS

Test Condition	Flight Number	RPM	BPF Hz	Insertion Loss at Given Harmonic Order, dB											
				1	2	3	4	5	6	7	8	9	10		
1	Flight 3	1520.0	76.0	0.5	4.8	6.3	15.5	11.1	14.6						
2	-	1570.0	78.5	1.3	8.0	1.1	6.6	10.7		10.5					
3	Flight 4	1572.5	78.6	15.6	-1.9	1.0	3.4	1.7	10.7	4.4	11.5				
4		1517.5	75.9	1.2	3.7	4.4	-6.4	10.4	8.1	4.5					
9		1530.0	76.5	1.4	2.6	1.7	-3.4	6.9	-1.5						
10		1572.5	78.6	9.7	10.1	1.4	2.9	-1.1	5.0	12.5					
11		1515.0	75.8	2.1	-0.8	2.6	1.2	8.1	5.9	10.2	10.7	7.4	11.3		
17		1517.5	75.9	-2.6	-3.8	-3.6	-1.4	13.4	9.9	22.6	8.5	6.0			
18		1572.5	78.6	8.4	2.8	5.0	-1.5	11.1	3.7	22.2	12.2	9.1	10.7		

CABIN MICROPHONE NUMBER 3 : PORT ENGINE COMPONENTS

Test Condition	Flight Number	RPM	BPF Hz	Insertion Loss at Given Harmonic Order, dB											
				1	2	3	4	5	6	7	8	9	10		
1	Flight 3	1575.0	78.8	-1.2	-6.8	8.2	5.2	14.6	0.0	9.9					
2	-	1525.0	76.3	-3.3	-4.6	11.2	4.3	7.5	1.5						
3	Flight 4	1527.5	76.4	-6.7	11.7	10.5	2.6	5.6	-7.0						
4		1572.5	78.6	-12.9	-11.9	8.8	0.1	4.8	1.6	9.0	17.3				
9		1575.0	78.8	-17.6	6.3	10.4	4.9	5.1	-1.5	16.3	10.1	18.4			
10		1527.5	76.4	-3.3	8.5	4.2	3.9	6.7	12.1	10.1	16.5				
11		1520.0	76.0	-2.9	2.5	3.4	-4.7	5.0	9.6	6.9	14.0	11.5	15.0		
17		1570.0	78.5	0.5	2.0	-2.1	5.7	5.4	19.8	6.4	16.6	29.7	17.7		
18		1522.5	76.1	7.2	1.8	1.3	8.4	-1.7	8.2	8.5	15.5		20.5		

TABLE J.2

INSERTION LOSS AT PROPELLER HARMONICS

CABIN MICROPHONE NUMBER 6 : STARBOARD ENGINE COMPONENTS

Test Condition	Flight Number	RPM	BPF Hz	Insertion Loss at Given Harmonic Order, dB										
				1	2	3	4	5	6	7	8	9	10	
1	Flight 3	1520.0	76.0	1.8	-8.1	9.2	9.7	15.1			11.9			
2	-	1570.0	78.5	2.2	-0.2	5.7	-2.9	21.5						
3	Flight 4	1572.5	78.6	1.0	-1.8	-5.7	5.5	-0.2	9.4					
4		1517.5	75.9	1.6	-2.9	-0.5	0.5	8.4	5.1	12.8				
9		1530.0	76.5	2.3	-5.5	1.1	-0.2	-5.0						
10		1572.5	78.6	6.6	-8.8	0.0	2.6	-8.7	6.0	8.0	15.0			
11		1515.0	75.8	3.3	-1.2	-3.0	8.1	3.1	-3.8	18.8	6.8	11.3	14.7	
17		1517.5	75.9	-0.8	-1.4	3.2	-10.9	-3.0	2.8	24.0	8.9		68.2	
18		1572.5	78.6	2.8	-4.3	6.0	2.3	3.2	-2.8	10.2	6.9	9.9	10.9	

CABIN MICROPHONE NUMBER 6 : PORT ENGINE COMPONENTS

Test Condition	Flight Number	RPM	BPF Hz	Insertion Loss at Given Harmonic Order, dB										
				1	2	3	4	5	6	7	8	9	10	
1	Flight 3	1575.0	78.8	10.9	-8.5	-9.9	-6.5	16.8	-2.5	13.7				
2	-	1525.0	76.3	6.2	-11.3	-13.6	-2.6	8.0	-0.7					
3	Flight 4	1527.5	76.4	4.7	-13.3	-14.5	-9.3	-3.1	-1.0	9.2	13.2			
4		1572.5	78.6	10.7	-9.0	-9.2	-1.3	2.6	-1.3	6.0	5.9			
9		1575.0	78.8	11.7	-6.8	-4.6	-1.2	2.3	-5.6	6.7	8.0	5.0		
10		1527.5	76.4	3.9	-10.4	-10.8	1.6	0.9	-7.7	3.3				
11		1520.0	76.0	-0.6	-18.2	-7.0	1.3	3.6	-2.3	2.8	14.6	15.8	10.4	
17		1570.0	78.5	12.0	-10.2	-5.6	-3.4	-1.3	8.2	11.8	9.9	9.6		
18		1522.5	76.1	6.2	-9.3	-5.8	-0.1	-2.6	9.5	7.1	15.6			

TABLE J.3

ONE-THIRD OCTAVE BAND SOUND PRESSURE LEVELS, FLIGHT #3 - FLIGHT#4
CABIN MICROPHONE NUMBER 3

Band Center Frequency Hz	Insertion Loss, dB								
	Test Condition								
	1	2	3	4	5	6	7	8	9
25	-13.5	-12.7	-14.5	-17.3					-13.7
32	-1.7	1.0	-6.5	-8.7					-7.5
40	-3.7	-4.3	-5.5	-4.2					-3.3
50	-4.3	-5.3	-8.5	-7.0					-7.7
63	-0.2	-2.0	-4.0	-2.8					-1.2
80	-1.3	-2.7	-4.5	-5.0					-5.2
100	-0.5	-1.0	-1.5	-2.3					-2.0
125	2.7	2.2	3.8	2.3					3.5
160	-0.5	2.0	5.5	-1.0					4.3
200	6.8	7.0	6.5	5.3					5.5
250	7.3	5.0	5.7	7.7					6.5
315	12.3	10.3	4.7	4.3					4.5
400	12.0	11.2	6.8	9.5					8.0
500	13.0	11.5	13.2	13.5					9.3
630	17.3	16.2	15.8	14.5					14.8
800	16.3	15.8	15.3	16.5					16.2
1000	13.7	14.0	15.5	17.0					17.2
1250	14.0	13.8	15.5	16.8					17.0
1600	14.2	13.7	16.3	17.5					17.7
2000	13.8	13.5	13.3	14.7					15.0
2500	14.0	12.8	14.8	15.5					16.0
3150	12.8	12.0	12.5	13.8					14.0
4000	9.7	9.5	10.2	11.5					11.3
5000	7.0	7.2	8.5	9.0					9.5

TABLE J.3 (CONTINUED)

ONE-THIRD OCTAVE BAND SOUND PRESSURE LEVELS. FLIGHT #3 - FLIGHT#4
CABIN MICROPHONE NUMBER 3

Band Center Frequency Hz	Insertion Loss, dB								
	Test Condition								
	10	11	12	13	14	15	16	17	18
25	-14.7	-13.2	-15.0	-10.3				-13.7	-14.2
32	-6.2	1.0	-3.7	-5.5				-10.7	-8.5
40	-3.5	-2.7	-3.2	-1.5				-3.5	-2.0
50	-8.0	-1.5	-3.0	-3.5				-2.8	-3.8
63	-1.0	2.2	-2.3	0.0				-1.3	7.0
80	0.5	2.5	-2.2	0.2				-0.8	7.5
100	-0.2	1.8	-2.5	0.5				-0.3	2.3
125	4.0	1.5	2.0	1.0				0.8	2.5
160	8.5	-0.2	3.3	0.0				0.5	2.8
200	4.8	1.8	3.5	2.8				3.0	4.5
250	2.7	2.2	3.5	-0.5				-2.5	3.2
315	4.5	3.0	1.5	4.2				4.8	5.3
400	8.5	8.7	8.5	9.0				11.2	8.2
500	12.7	11.0	12.0	11.2				13.2	7.7
630	17.0	15.5	17.0	17.2				15.0	15.0
800	16.0	15.0	15.0	15.2				14.0	13.5
1000	17.0	13.7	13.5	15.2				15.0	14.3
1250	16.2	12.5	12.0	15.8				16.2	16.3
1600	16.5	13.8	14.3	17.3				16.3	16.2
2000	14.5	10.5	13.0	13.2				12.3	13.3
2500	15.5	12.8	13.5	13.8				12.8	13.3
3150	13.0	9.5	10.2	11.5				11.0	11.0
4000	10.5	6.5	7.7	8.2				8.0	8.3
5000	9.0	4.3	6.7	7.0				6.0	7.0

TABLE J.4

ONE-THIRD OCTAVE BAND SOUND PRESSURE LEVELS. FLIGHT #3 - FLIGHT#4
CABIN MICROPHONE NUMBER 6

Band Center Frequency Hz	Insertion Loss, dB								
	Test Condition								
	1	2	3	4	5	6	7	8	9
25	-1.8	-1.3	-1.8	-3.8					-0.5
32	12.5	15.2	6.5	4.2					5.5
40	2.7	3.2	3.0	4.3					5.3
50	-9.0	-8.3	-9.3	-8.3					-8.0
63	6.2	5.5	4.5	7.3					7.5
80	8.2	5.0	3.8	9.0					9.2
100	7.0	3.5	2.7	7.2					7.5
125	-2.3	-4.3	-5.3	-3.5					-3.5
160	-6.8	-6.8	-6.3	-7.0					-5.3
200	-1.3	-1.8	-2.0	-4.0					-2.0
250	-6.3	-4.8	-7.8	-5.8					-3.5
315	3.0	4.3	4.3	2.5					2.3
400	14.0	13.8	7.5	6.5					5.3
500	13.5	13.0	12.0	9.8					6.7
630	19.0	19.0	17.2	18.0					17.3
800	16.8	17.8	17.5	17.5					17.8
1000	15.5	16.3	17.0	17.7					18.3
1250	14.0	14.7	17.7	18.8					20.0
1600	14.2	14.5	17.5	18.5					20.0
2000	13.7	12.3	16.5	17.2					18.3
2500	14.2	14.3	14.7	16.5					17.0
3150	14.7	14.7	14.5	15.3					15.0
4000	12.5	12.2	12.5	12.5					13.0
5000	10.3	10.3	10.3	11.2					11.5

TABLE J.4 (CONTINUED)

ONE-THIRD OCTAVE BAND SOUND PRESSURE LEVELS. FLIGHT #3 - FLIGHT#4
CABIN MICROPHONE NUMBER 6

Band Center Frequency Hz	Insertion Loss, dB								
	Test Condition								
	10	11	12	13	14	15	16	17	18
25	-1.0	-1.0	-2.0	2.7				-0.5	-0.5
32	7.5	15.0	8.8	7.7				2.5	4.2
40	4.2	5.5	5.3	6.0				4.8	6.0
50	-7.8	-3.3	-8.8	-5.8				-7.8	-5.3
63	5.5	4.3	-0.5	.0				4.0	4.5
80	5.8	3.7	-0.5	0.2				7.0	4.3
100	4.3	2.7	1.8	1.8				5.8	3.8
125	-6.3	-1.0	-9.8	-7.5				-3.8	-5.3
160	-9.5	-1.0	-15.5	-12.3				-6.5	-7.0
200	-0.5	0.3	-3.5	1.3				.0	1.2
250	-3.8	.0	-4.3	-3.0				-2.8	1.3
315	4.5	9.5	3.7	3.5				-1.3	3.0
400	5.8	10.7	7.0	5.8				2.7	5.5
500	10.2	11.7	7.2	9.2				10.0	6.8
630	17.0	16.5	16.7	18.0				16.8	18.0
800	17.3	17.0	17.0	17.3				17.0	18.3
1000	17.3	17.0	15.5	17.8				17.3	17.2
1250	18.8	16.8	18.0	20.2				19.7	19.8
1600	18.5	17.0	16.5	21.0				20.0	21.0
2000	16.7	15.0	15.5	17.8				16.3	17.5
2500	16.0	15.3	14.7	16.7				16.0	16.0
3150	15.0	14.0	14.5	15.3				13.7	15.3
4000	12.7	10.8	11.7	13.0				12.5	12.8
5000	10.3	9.3	10.5	11.5				11.2	11.8

APPENDIX K

Insertion Loss Provided by Treatment (Differences in Harmonic and One-Third Octave Band Sound Pressure Levels for Flights 3 and 4; Adjusted for Changes in Exterior Sound Pressure Level).

TABLE K.1

INSERTION LOSS AT PROPELLER HARMONICS, ADJUSTED FOR CHANGES IN EXTERIOR SOUND PRESSURE LEVEL

CABIN MICROPHONE NUMBER 3 : STARBOARD ENGINE COMPONENTS

Test Condition	Flight Number	RPM	BPF Hz	Insertion Loss dB													
				1	2	3	4	5	6	7	8	9	10				
1	Flight	1520.0	76.0	1.1	5.5	6.6	17.0	13.1	16.1								
2	3	1570.0	78.5	1.8	8.6	0.8	7.5	11.4			11.8						
3	-	1572.5	78.6	16.5	-1.1	2.8	4.7	3.8	11.1	6.3	12.4						
4	Flight	1517.5	75.9	1.7	4.0	5.0	-5.4	10.7	8.5	4.6							
9	4	1530.0	76.5	0.9	2.9	1.7	-3.2	6.6	0.0								
10		1572.5	78.6	10.0	9.8	2.2	3.1	-0.4	6.5	12.5							
11		1515.0	75.8	2.2	-0.5	2.8	1.5	8.7	6.0	10.6	11.6	8.2	9.9				
17		1517.5	75.9	-2.6	-3.1	-3.3	-1.5	12.5	9.5	22.1	8.3	5.8					
18		1572.5	78.6	8.5	2.2	5.3	-2.1	10.4	3.9	21.2	12.3	8.7	10.3				

TABLE K.2

CABIN MICROPHONE 6 : PORT ENGINE COMPONENTS

Test Condition	Flight Number	RPM	BPF Hz	Insertion Loss, dB													
				1	2	3	4	5	6	7	8	9	10				
1	Flight 4	1575.0	78.8	15.2	-4.4	-5.8	-1.9	21.5	1.6	18.2							
2	-	1525.0	76.3	10.8	-6.6	-8.7	1.9	12.1	4.9								
3	Flight 3	1527.5	76.4	8.6	-8.4	-9.7	-5.0	1.1	4.3	14.9	17.8						
4		1572.5	78.6	14.3	-5.8	-5.3	2.3	6.1	2.5	9.2	9.7						
9		1575.0	78.8	15.1	-3.6	-1.3	2.8	6.5	-2.9	10.5	12.1	8.6					
10		1527.5	76.4	7.5	-6.0	-6.1	5.8	5.4	-1.3	8.1							
12		1520.0	76.0	2.4	-15.0	-3.9	4.7	7.1	1.1	6.4	17.3	20.5	13.7				
17		1570.0	78.5	14.8	-6.5	-1.9	0.1	2.3	11.5	15.3	13.7	13.1					
18		1517.5	75.9	9.2	-5.8	-2.8	3.1	1.5	13.7	10.8	19.3						

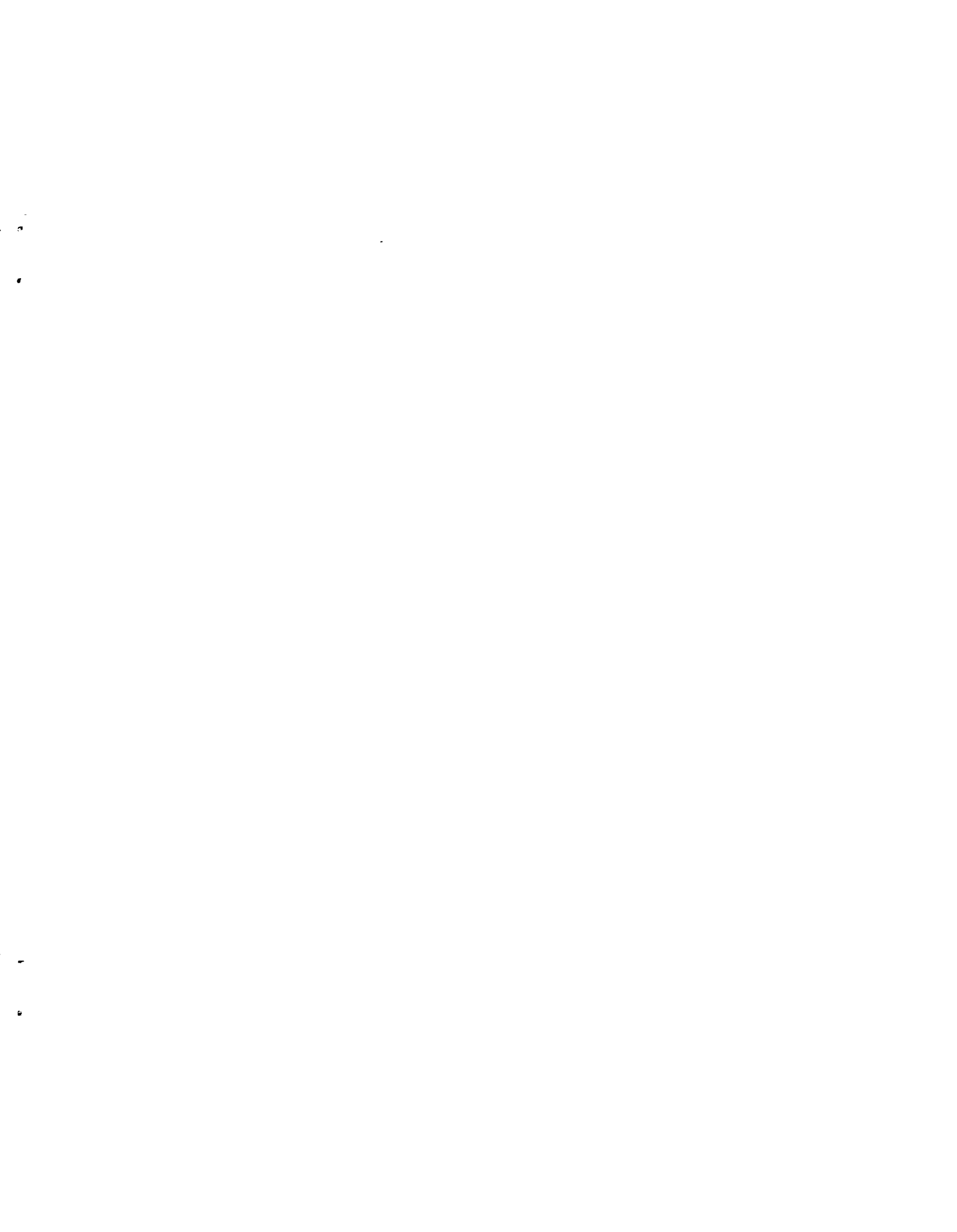

Standard Bibliographic Page

1. Report No. NASA CR-178004	2. Government Accession No.	3. Recipient's Catalog No.	
4. Title and Subtitle IN-FLIGHT ACOUSTIC MEASUREMENTS ON A LIGHT TWIN-ENGINEED TURBOPROP AIRPLANE		5. Report Date November 1985	
		6. Performing Organization Code	
7. Author(s) J. F. Wilby, C. D. McDaniel and E. G. Wilby		8. Performing Organization Report No. 5838	
		10. Work Unit No.	
9. Performing Organization Name and Address BBN Laboratories Incorporated 21120 Vanowen Street Canoga Park, CA 91303		11. Contract or Grant No. NAS1-16521	
		13. Type of Report and Period Covered Contractor Report	
12. Sponsoring Agency Name and Address National Aeronautics and Space Administration Washington, DC 20546		14. Sponsoring Agency Code	
15. Supplementary Notes NASA Langley Technical Monitor: Dr. John S. Mixson Final Report			
16. Abstract Four series of flight tests were conducted to measure sound pressure levels inside and outside the cabin of a twin-engined turboprop airplane. Particular emphasis was placed on harmonics of the propeller blade passage frequency. The cabin was unfurnished for the first three flights, when the main objective was to investigate the repeatability of the data. For the fourth flight, the cabin was treated with fiberglass batts. Typically, the exterior sound pressure levels were found to vary 3 to 5 dB for a given harmonic, but variations as high as 8 dB were observed. The variability of harmonic levels within the cabin was slightly higher but depended on control of the relative phase between the propellers; when phase was not controlled the average variability was about 10 dB. Noise reductions provided by the fuselage structure were in the range of 20 to 40 dB, when an exterior microphone in the plane of rotation of the propeller was used as reference. Installation of 5 cm of fiberglass blanket on the cabin walls and ceiling increased the noise reduction at frequencies above about 200 Hz, but there was an apparent decrease in noise reduction at some lower frequencies.			
17. Key Words (Suggested by Authors(s)) Airplane Interior Noise Propeller Noise Flight Test Data Repeatability Noise Reduction		18. Distribution Statement Unclassified - Unlimited Subject Category 71	
19. Security Classif.(of this report) Unclassified	20. Security Classif.(of this page) Unclassified	21. No. of Pages 230	22. Price All

For sale by the National Technical Information Service, Springfield, Virginia 22161



