

**NASA
Technical
Paper
2575**

March 1986

NASA-TP-2575 19860012088

Graphical Techniques To Assist in Pointing and Control Studies of Orbiting Spacecraft

Leonard W. Howell
and Joseph H. Ruf

LIBRARY COPY

MAR 23 1986

LANGLEY RESEARCH CENTER
LIBRARY, NASA
HAMPTON, VIRGINIA

NASA

**NASA
Technical
Paper
2575**

1986

Graphical Techniques To Assist in Pointing and Control Studies of Orbiting Spacecraft

Leonard W. Howell
and Joseph H. Ruf

*George C. Marshall Space Flight Center
Marshall Space Flight Center, Alabama*



National Aeronautics
and Space Administration

Scientific and Technical
Information Branch

TABLE OF CONTENTS

	Page
I. INTRODUCTION.....	1
II. GENERAL METHODS.....	1
A. Earth Model	1
B. Spacecraft Geometrical Model	3
C. Spacecraft in Earth Orbit.....	5
D. Generation of Star Displays.....	6
E. Data Acquisition.....	11
III. CONCLUSION	11
APPENDIX A – STEREO VISUALIZATION WITHOUT OPTICAL AIDS	12

LIST OF ILLUSTRATIONS

Figure	Title	Page
1a.	Stereoscopic view of North and South America	2
1b.	Stereoscopic view of the North Pole	2
1c.	Stereoscopic view of Asia, Indonesia, and Australia	3
2a.	Geometrical model of the HST	4
2b.	Space city	4
3.	Display of HST in Earth-orbit	5
4.	Intersection of the Telescope's Line-of-sight with the Earth	6
5a.	HST shown with its star tracker's line-of-sight vectors and body coordinate frame	7
5b.	Telescope's focal plane with various scientific instruments	7
5c.	Telescope's FOV and nearby stars	8
6.	Star tracker FOV's	8
7a.	Two degree FOV at RA of 27 deg, DL of 89 deg showing the 0.5 deg wide HST FOV	9
7b.	Change of declination of 88.75 deg	10
7c.	Change of declination to 88.5 deg	10
A-1.	Stereo projection	13
A-2.	Stereo reconstruction by cross-eyed viewing	14
A-3.	Projection geometry	14

TECHNICAL PAPER

GRAPHICAL TECHNIQUES TO ASSIST IN POINTING AND CONTROL STUDIES OF ORBITING SPACECRAFT

I. INTRODUCTION

In future space missions which involve orbiting spacecraft it will be important to graphically display the spacecraft in its orbit relative to the Earth and have realistic star pattern diagrams as might be seen by on-board telescopes and star sensors. These graphical displays can then be used in conjunction with dynamic simulations or telemetered flight data to provide a quick-look assessment of the vehicle's pointing and control system and orbital position.

The computer graphics presented in this paper can be adapted to an arbitrary spacecraft design in order to provide these capabilities and simulate the field-of-view (FOV) of the forward optical sensors and/or the spacecraft's star sensors.

These techniques were developed in A Programming Language (APL) on a Xerox Sigma-V computer using a Textronix 4015-1 terminal. The programs used to generate the graphics are written in standard APL and have no system-unique requirements. The star search routine is written in standard FORTRAN. Star positions and corresponding visual magnitudes of stars were taken from the Skymap Star Catalog which was prepared in 1975 specifically for attitude determination purposes. It contains approximately 255,000 stars ranging in visual magnitude from -1.45 to slightly dimmer than 10.0. The catalog is 90 to 100 percent complete for stars to 9.0 magnitude.

To minimize the computer storage space required, star positions were computed for summer 1986 which corresponds to the expected orbital verification time-frame of the Hubble Space Telescope (HST). This eliminated the necessity for storing the proper motion parameters for the stars. Also, the resulting data (right ascension, declination, and visual magnitude of each star) is represented as integers for additional savings.

II. GENERAL METHODS

A. Earth Model

To graphically display a spacecraft in Earth orbit, a three-dimensional stereoscopic model of the Earth was first constructed. The Earth model includes all major land masses, latitude and longitude lines, and many significant islands. Also, outlines of other predominant features such as the South Atlantic Anomaly can be included.

The Earth model is constructed from latitude and longitude points which define the shape of the displayed land masses. These points are then transformed into rectangular coordinates and passed to the stereoscopic program which generates the stereoscopic pair (see Appendix A on cross-eyed stereo visualization).

Displays of the Earth model can be generated that give good representations of the view of the Earth as seen from any location in space. This is done by entering the latitude and longitude of the desired vantage point as arguments of the APL function DRGLOBE (D_Raw GLOBE). Execution of DRGLOBE produces a stereoscopic pair of the Earth with the back side of the Earth being suppressed.

For example, a view of North America is obtained by entering the following APL command (Fig. 1a):

```
270 DRGLOBE 15 .
```

This is the view of North America as it would be seen from a point on the ray defined by 270 deg longitude and 15 deg latitude. Note that a portion of the South Atlantic Anomaly is also included. Some other possibilities are shown in Figure 1b (North Pole) and Figure 1c (Eurasia/Middle East).

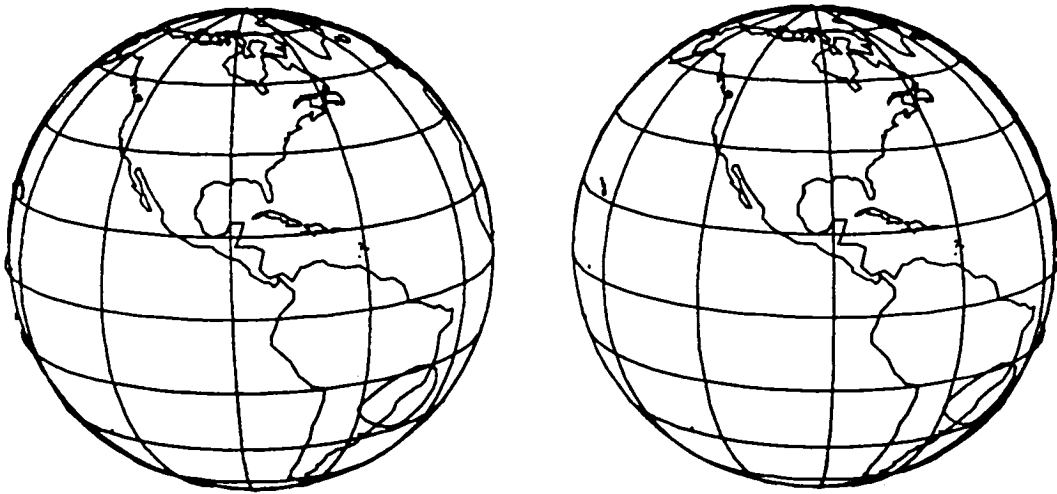

Figure 1a. Stereoscopic view of North and South America.

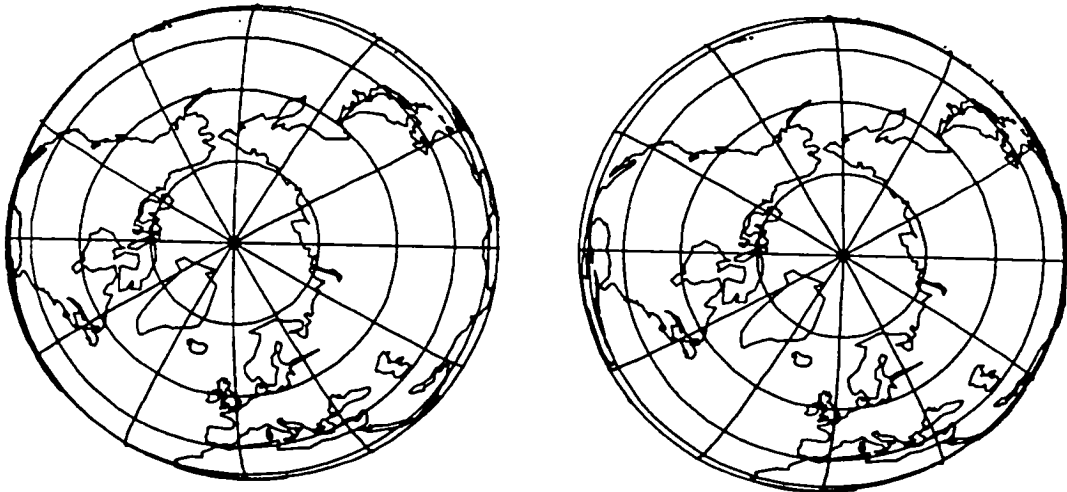

Figure 1b. Stereoscopic view of the North Pole.

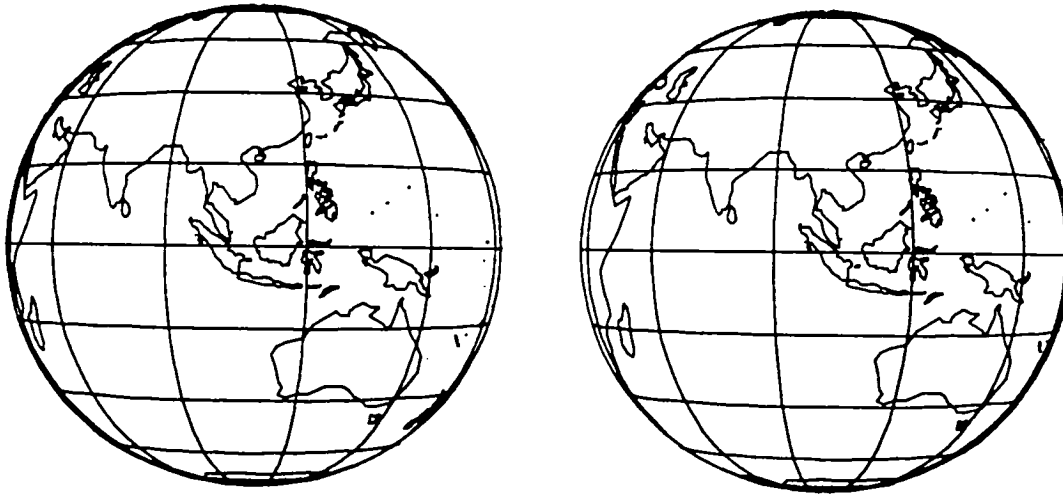

Figure 1c. Stereoscopic view of Asia, Indonesia, and Australia.

B. Spacecraft Geometrical Model

In order to model a spacecraft in orbit, it is first necessary to have a geometrical representation of the spacecraft. The geometrical model need only be detailed enough to distinguish its orientation but may be more complete for aesthetic appeal.

Using a set of generic shapes, such as cylinders, boxes, and paraboloids, a geometrical model can be assembled which adequately resembles the spacecraft with the level of detail being dependent upon the modeling objective.

The following generic objects were chosen as the basic building blocks for spacecraft geometrical models:

- 1) Sphere
- 2) Cone
- 3) Cylinder
- 4) Box
- 5) Cap from a sphere
- 6) Frustum
- 7) Paraboloid
- 8) Ellipsoid.

These objects can then be assembled to describe most vehicles that one is likely to encounter; unusual shapes can be created by merging combinations of these figures together when necessary.

The following figures depict assembled geometrical models. Figure 2a shows a model of the HST which is used in the example. Figure 2b is a futuristic "space city" and has been included to illustrate the flexibility of these methods.

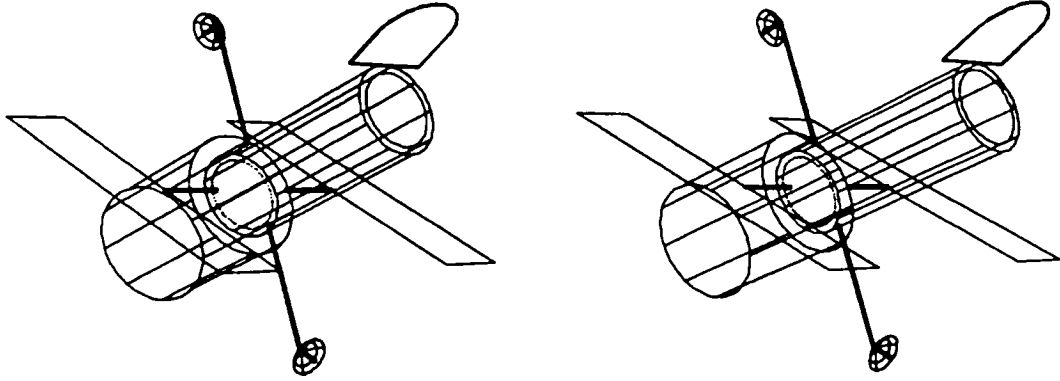

Figure 2a. Geometrical model of the HST.

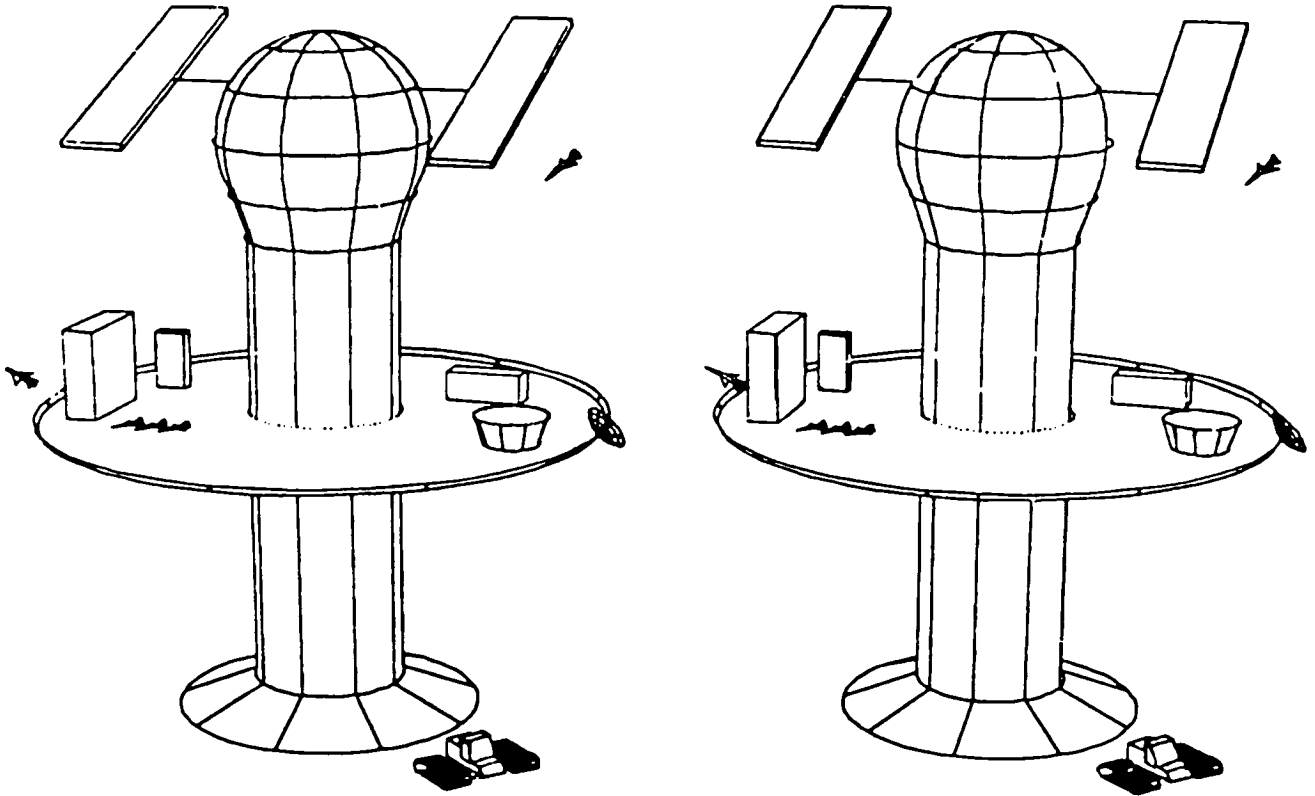

Figure 2b. Space city.

C. Spacecraft in Earth Orbit

The Earth and spacecraft models are displayed together by the program HSTEARTH (Hubble Space Telescope and EARTH) to help the user visualize the relationship between the spacecraft's position and orientation relative to the Earth. In order to display the spacecraft in orbit the user enters the position of the spacecraft in terms of longitude (measured in degrees from the Greenwich meridian) and latitude (degrees from the equator) as a parameter to the APL program HSTEARTH, along with a second argument which defines the desired line-of-sight in degrees of right ascension (RA) and declination (DL) relative to the celestial sphere. For example, if the spacecraft is positioned at 70 deg longitude, 15 deg latitude, and is pointing in the direction of the star Altair, (RA 297, DL 8.6), the command

```
70 15 HSTEARTH 297 8.6
```

produces the display shown in Figure 3.

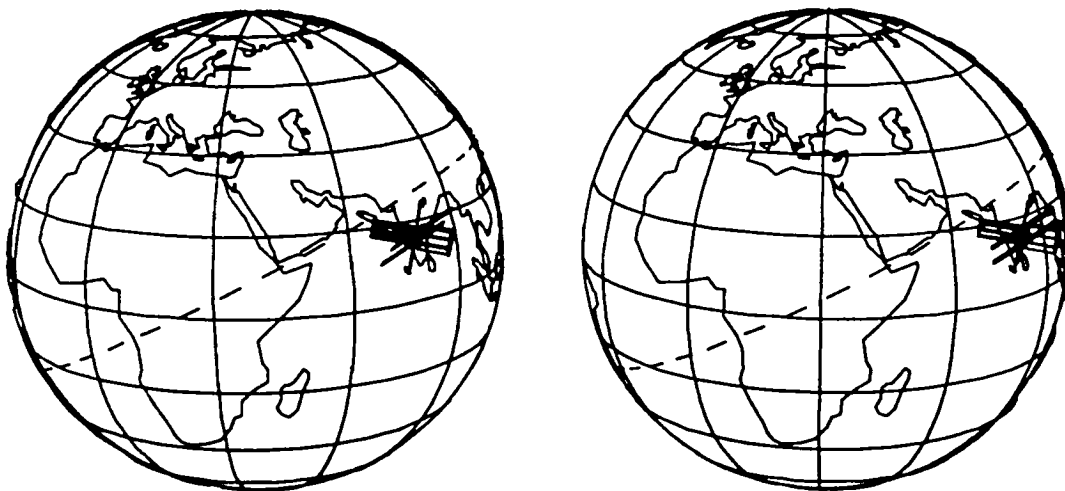

Figure 3. Display of HST in Earth-orbit.

If, as in the case of the HST, the spacecraft is in a low Earth-orbit, the line-of-sight will often intersect the Earth. To accommodate this situation, programs were developed which determine if the telescope's line-of-sight intersects the Earth. The parameters of this program are the altitude of the spacecraft and its location and orientation with respect to the Earth. The altitude is defined in HSTEARTH as a global variable in Earth-radii units.

To determine if the telescope's FOV is blocked by the Earth, the APL function FIREPHOTON is executed following the completion of HSTEARTH. The program responds with either "EARTH NOT IN FIELD OF VIEW" or with the latitude and longitude of the point where the line-of-sight intersects the Earth. In the graphical display a dotted line is then drawn along the line-of-sight if it intersects the Earth, as illustrated in Figure 4.

To display the present orbital groundtrack (as shown in Figs. 3 and 4) of the spacecraft, the user enters DRORBIT (DRaw ORBIT). The function DRORBIT obtains the location of the spacecraft from HSTEARTH and then calculates the groundtrack based on the orbital parameters, e.g., inclination of orbit, defined in DRORBIT.

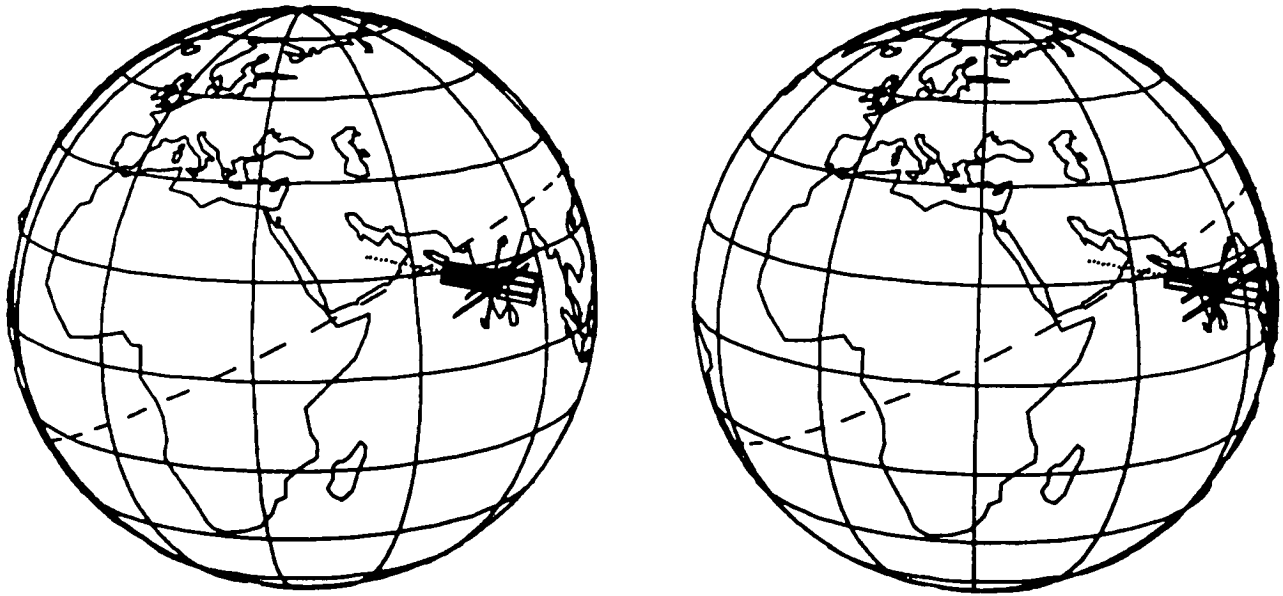

Figure 4. Intersection of the Telescope's line-of-sight with the Earth.

D. Generation of Star Displays

Several computer programs were developed to realistically provide the FOV of a spacecraft's optical instruments and star trackers.

The input parameters required are the RA, DL, and appropriate dimensions of the fields-of-view. The RA and DL of the line-of-sight vector is based on the standard right ascension and declination coordinate system of the celestial sphere. The FOV size is specified by a half cone angle in degrees in the case of optical telescopes but can be changed as required for other instruments.

After obtaining the telescope's FOV, the spacecraft's star trackers' FOV's can next be generated by executing the APL function STARTRACKERVIEW. The orientation of the star trackers is defined in terms of their line-of-sight vectors in spacecraft body coordinates as illustrated in Figure 5a (note the V1-V2-V3 body coordinate frame). These line-of-sight vectors are initialized in STARTRACKERVIEW and are displayed by executing STARTRACKER. In the case of the HST, the geometrical model can be included in this display by the command 0 0 DRTELES RA, DL. Once these parameters have been defined, the direction and FOV of each of the star trackers is automatically calculated for each new orientation of the spacecraft. The arguments to STARTRACKERVIEW are the RA and DL of the telescope.

For example, to study the star Polaris using the HST, it is necessary to know which stars are available for the star trackers to use for coarse attitude update to assist in vehicle maneuvering. To obtain these FOV's, the FORTRAN program SEARCH is executed using the RA and DL of Polaris and then the APL function STARFIELD is executed (see Section E on Data Acquisition).

STARFIELD generates the FOV of the telescope's primary mirror with the focal plane of the telescope superimposed on the view. The focal plane of the HST with its various scientific instruments is depicted in Figure 5b. In both functions STARFIELD and APLSEARCH the focal plane is displayed in the correct perspective with the stars in their proper location and relative visual magnitudes.

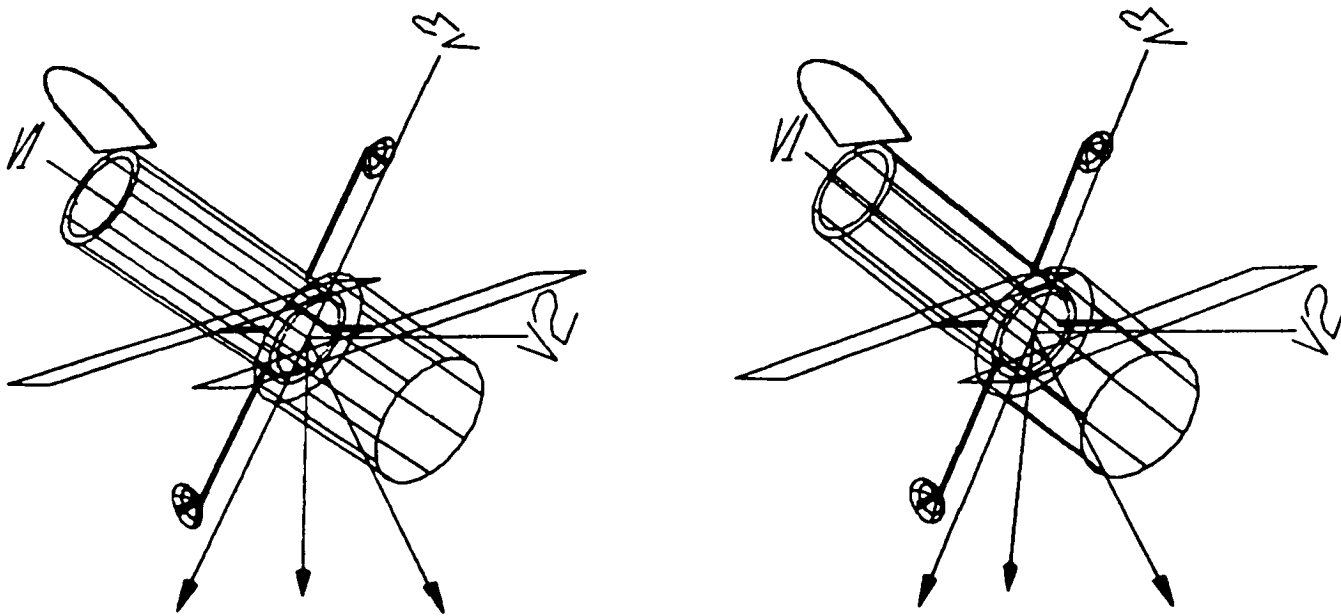

Figure 5a. HST shown with its star tracker's line-of-sight vectors and body coordinate frame.

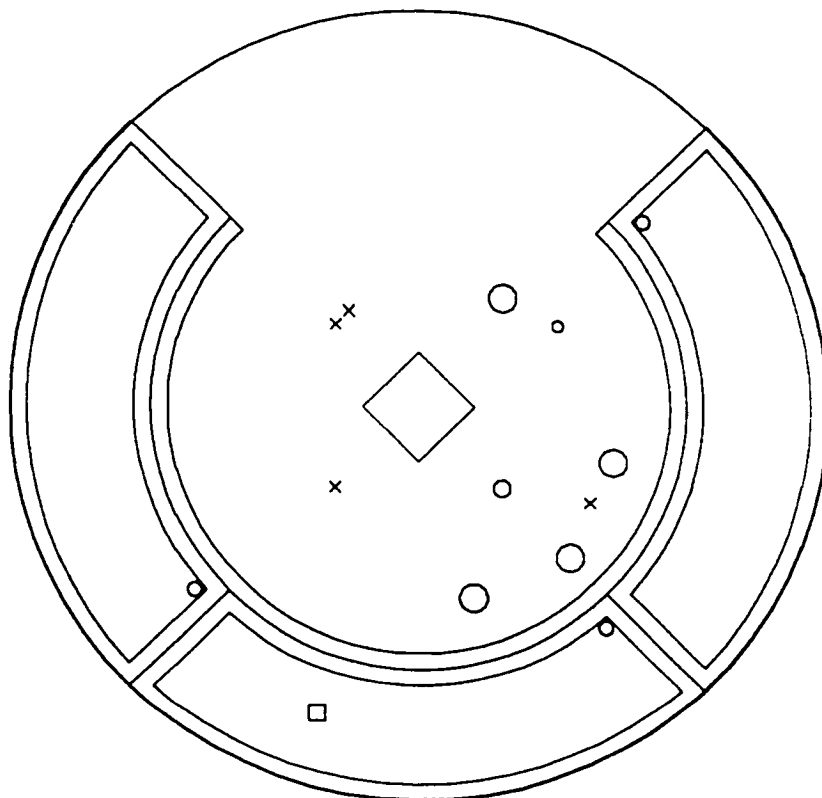

Figure 5b. Telescope's focal plane with various scientific instruments.

The corresponding FOV's of the star trackers can then be obtained by executing the program STARTRACKERVIEW which generates Figure 6. In the case of the HST, the star tracker FOV's are 8 deg squares which require projecting intersecting lunes onto the celestial sphere as indicated in Figure 6.

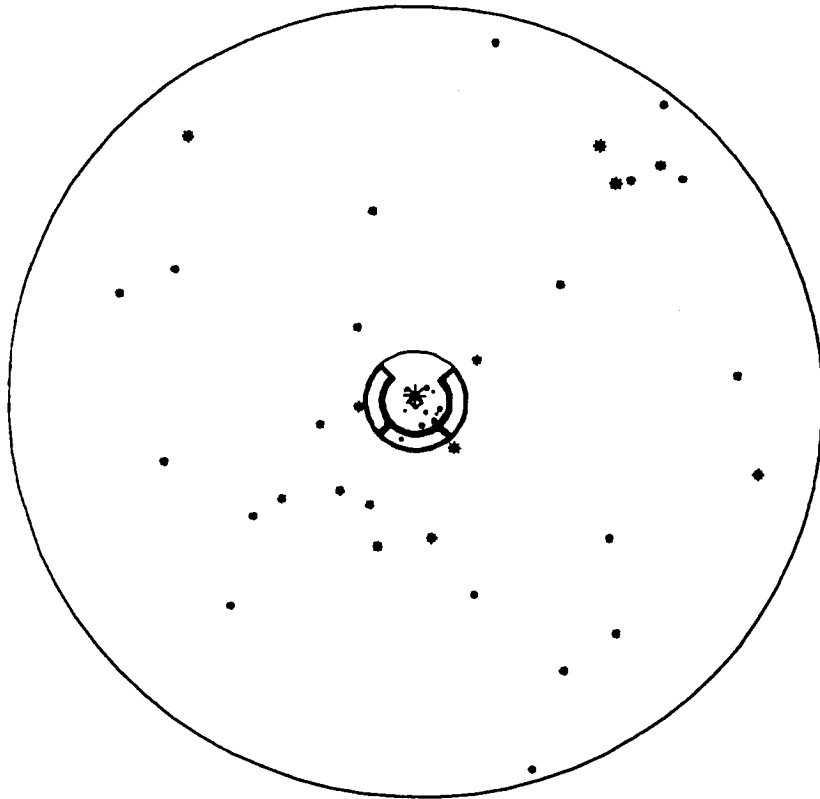

Figure 5c. Telescope's FOV and nearby stars. (Note Polaris in the center and Ursa Minor in the lower half of the disk.)

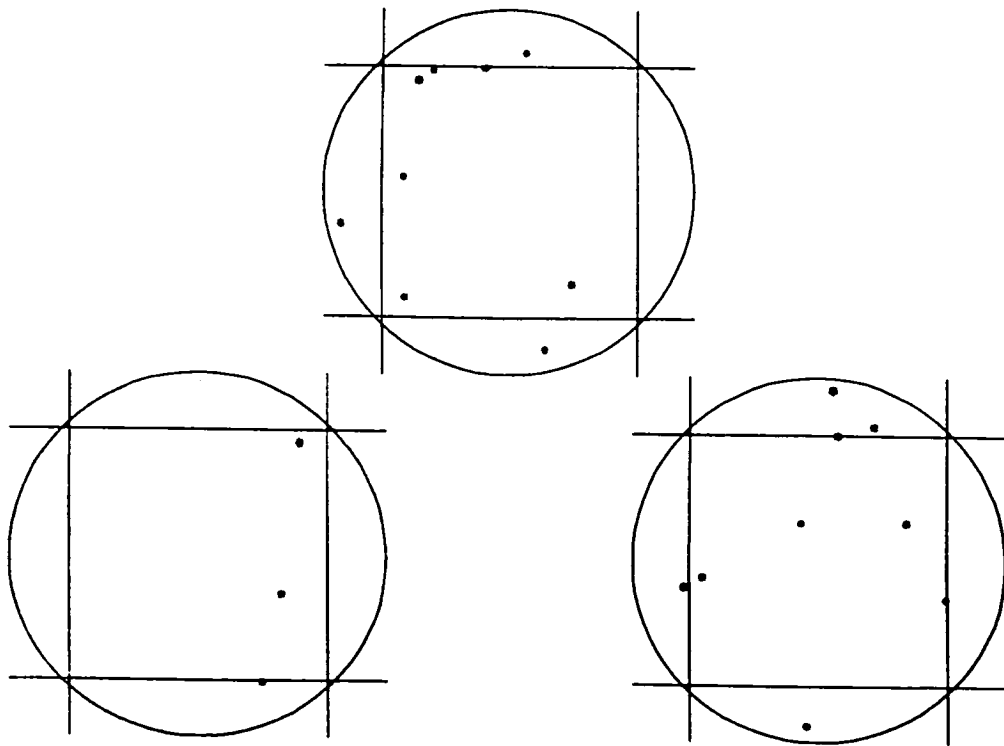

Figure 6. Star tracker FOV's.

To produce the exact FOV of the telescope's primary mirror the APL function APLSEARCH is executed. The HST's primary mirror FOV is 0.5 deg but the graphics programs allow the user to specify any size half cone angle. The arguments of APLSEARCH are the RA and DL of the line-of-sight and the half cone angle which defines the telescope's FOV. By varying the half cone angle the user can simulate a zoom effect or show the FOV relative to the stars just outside the FOV. For example, the command APLSEARCH 27 89 1 produces Figure 7a which shows the stars that are within a one degree half cone angle of Polaris with the outline of the telescope's 0.5 deg FOV and the scientific instruments in their relative size.

By specifying slight variations in the RA and DL and keeping the half cone angle large enough to see stars outside the primary mirror's FOV the user can simulate the telescope maneuvering to a new position (Fig. 7b and 7c). Obviously, however, the RA and DL specified when using APLSEARCH should be within the region defined by the RA, DL, and half cone angle used in the FORTRAN search routine.

In both the STARFIELD and STARTRACKERVIEW graphics the relative visual magnitudes of the stars are indicated by the relative sizes of the stars in the display. Thus, the brighter stars are drawn larger than the dimmer stars.

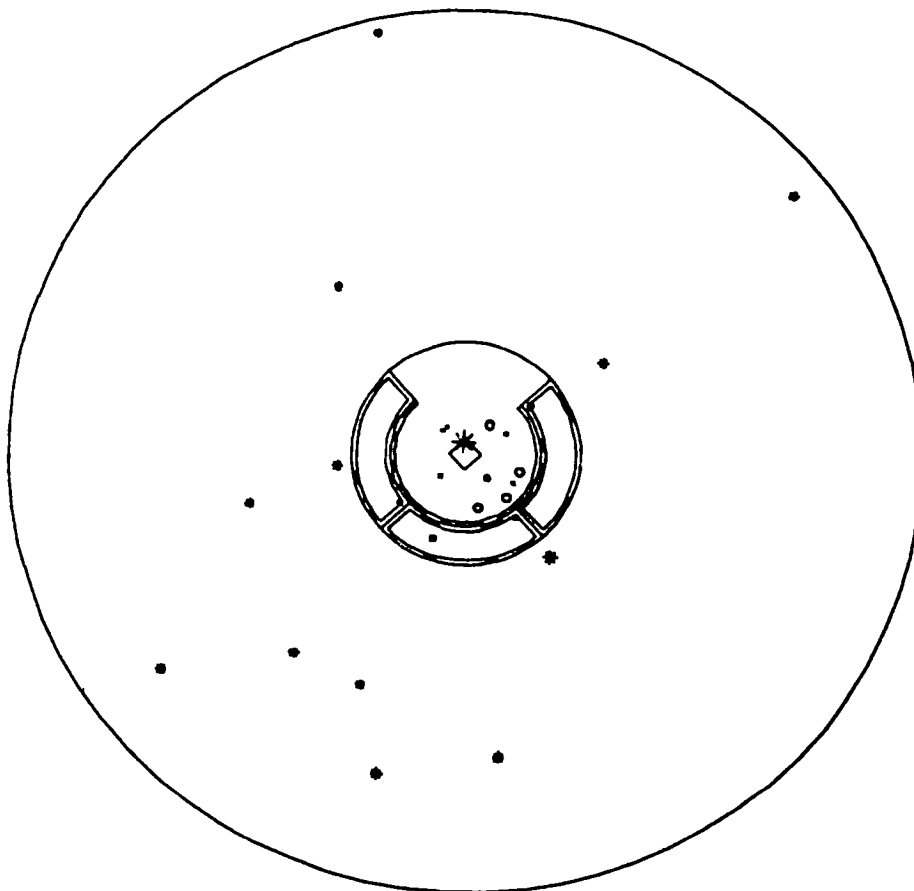

Figure 7a. Two degree FOV at RA of 27 deg, DL of 89 deg showing the 0.5 deg wide HST FOV.

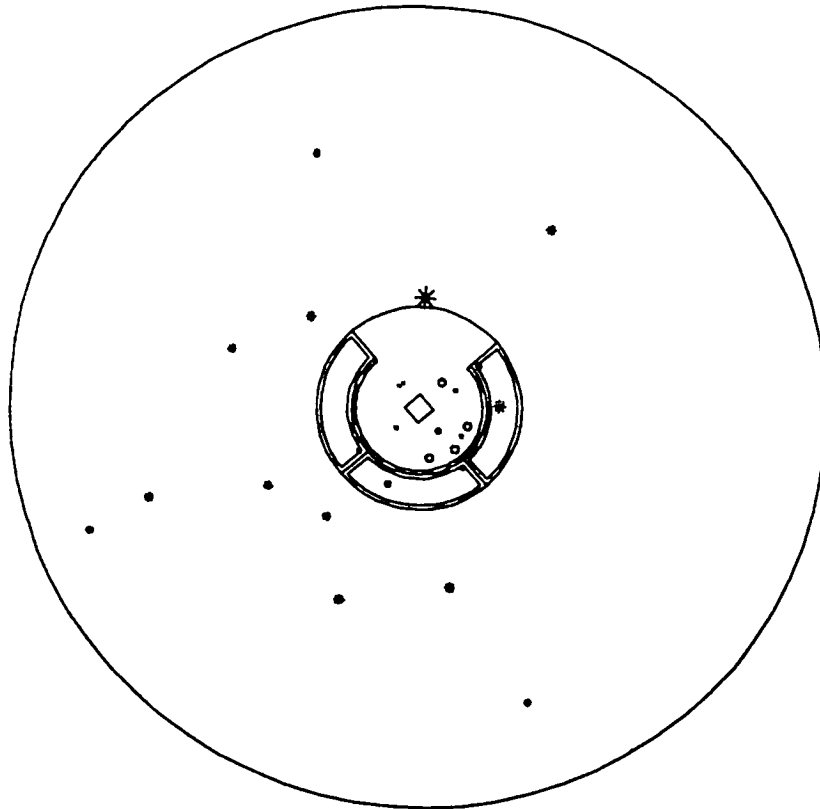

Figure 7b. Change of declination to 88.75 deg. (Note apparent shift of stars.)

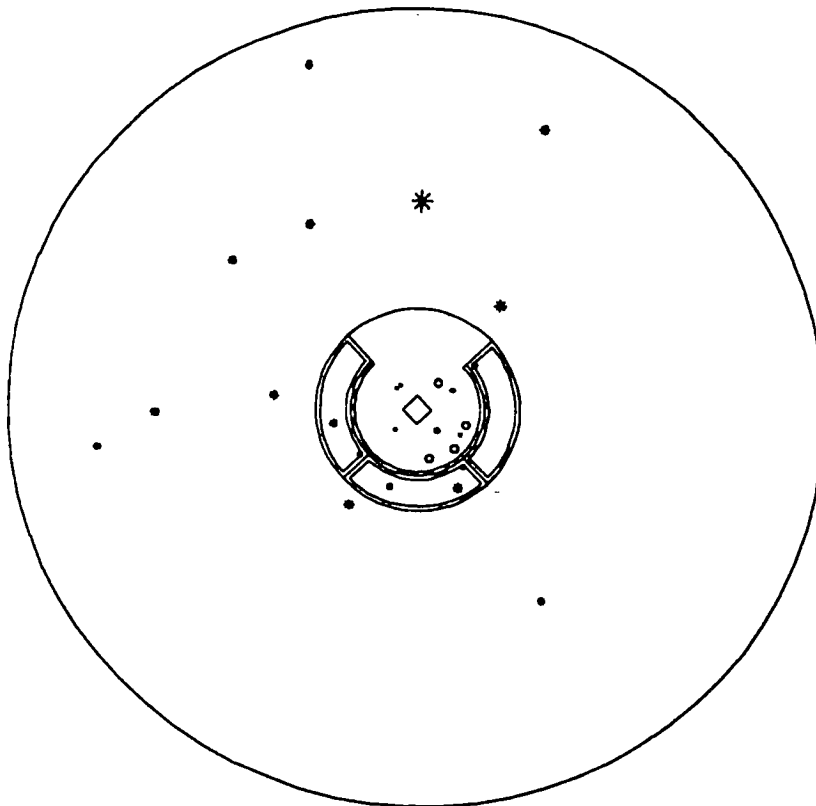

Figure 7c. Change of declination to 88.5 deg.

E. Data Acquisition

The star data used in these graphics is in the file SIGSKYMAP generated from the Skymap Star Catalog. SIGSKYMAP contains the RA and DL (for summer 1986), and corresponding visual magnitude of 248,727 stars.

To avoid overloading the APL graphics workspace with this large data base, it was necessary to put the data in a direct access file which is then utilized by a FORTRAN search program. Thus, in order to obtain the stars located in a particular portion of the celestial sphere, it is first necessary to run a FORTRAN program called SEARCH. To execute SEARCH, the user types BSEARCH, which then prompts for the RA and DL (in degrees), and the half cone angle (also in degrees) of the region to be searched. The next parameter requested is the minimum visual magnitude of the stars of interest. SEARCH then uses this information to retrieve the stars from the direct access data file SIGSKYMAP and writes the data to the file STARSFOUND. As a user option, the data may also be written to the screen.

Because of the granularity of the FORTRAN search procedure, the half cone angle should not be less than 2 deg. Smaller FOV's can then be accurately handled by the APL programs once the data is passed to the APL workspace.

The user must now enter APL to proceed with the graphics. The program STARFIELD is first executed which reads the file STARSFOUND and creates an APL variable named STARDAT; STARFIELD then proceeds with the star pattern/FOV displays. STARDAT is then used by the APL programs as a data base from which the primary mirror's FOV is visually constructed. Because the APL programs do not have the granularity constraint of the FORTRAN program, any FOV half cone angle is now acceptable.

In order to avoid exiting APL and having to run the FORTRAN programs to obtain the FOV for each of the star trackers a smaller data base has been stored in APL. This data base contains all the stars of visual magnitude 6.0 or brighter. This cut-off was chosen because the HST's star trackers can only use stars of this visual magnitude or brighter.

III. CONCLUSION

This paper presents a description of computer graphics which can be used to assist in studies of the pointing and control system of orbiting spacecraft. These graphics provide the capability to generate the following: an Earth model, arbitrary geometrical spacecraft model, an orbiting spacecraft and corresponding groundtrack, and the FOV of a spacecraft's forward optical sensors and various star sensors.

To illustrate these capabilities, a model of the HST is constructed and positioned in Earth-orbit. Primary mirror displays and corresponding star tracker FOVs are generated for various spacecraft attitudes.

APPENDIX A

STEREO VISUALIZATION WITHOUT OPTICAL AIDS*

(Cross-Eyed Stereo)

On many occasions in engineering and physical analysis, it would be useful to be able to sketch in three dimensions. To fulfill this wish in many cases, a convenient technique which requires no optical devices other than one's eyes may be used. All that is required is a stereoscopic pair of images. One additional capability is necessary. The observer must be able to cause the lines of sight of his eyes to converge; i.e., one must cross one's eyes. The stereo projections are formed as shown in Figure A-1. The images are reversed and viewed as in Figure A-2. With a little practice, one can easily learn to reconstruct mentally the 3-dimensional scene from the reversed stereo pairs. In this report there are two stereo pictures. The interested reader should try several viewing distances. (The farther away the page the less crossing of the eyes is required and the easier it becomes to focus the images.) Squinting may also help as it increases one's depth of focus. When one first looks at a stereo pair, one focuses on the page and sees two similar but separate images. As one begins to cross his eyes, the two images become four. Continue crossing the eyes until the interior pair of images come together. Since the line connecting corresponding points on the images must be at the same angle about the line of sight as the line connecting the eyes, it may be necessary to rotate the page or rock the head until these two images become superimposed and seem to merge into a stereo image. This technique does require some practice but once mastered it can be very useful for easy visualization in 3 dimensions.

If a computer plot capability is available, we can construct the necessary stereo projections from a set of points and lines that represent the object of interest. We have referred to such a representation as a wire frame model because of the appearance of the image. Let P be a representative point of the model. Each point P is projected into the picture plane S as shown in Figure A-3. The point P is projected to the eyepoint E and the line PE intersects the picture plane S at P' . P' is the projection of P onto S . The set of all points P' projected from object points P together with the connecting lines form the desired projection. We set up a reference frame in the plane S . To do this, we must specify which way is up (so to speak). Let \underline{u}_u be a unit vector in this direction and $\underline{u}_r = \underline{u}_u \times \underline{\ell}$ is a unit vector in S pointing to the right. We place the origin of the S coordinate reference at O . Observe that $\underline{r}_O = \underline{r}_E + d \underline{\ell}$ where \underline{r}_O and \underline{r}_E are position vectors of O and E , respectively. From the geometry shown in Figure A-3, we can see that

$$\underline{r}_{P'} = \underline{r}_E + (\underline{r}_P - \underline{r}_E) d/\ell \cdot (\underline{r}_P - \underline{r}_E) \cdot \underline{\ell}$$

From this we can compute

$$x_{P'} = (\underline{r}_{P'} - \underline{r}_O) \cdot \underline{u}_r$$

$$y_{P'} = (\underline{r}_{P'} - \underline{r}_O) \cdot \underline{u}_u$$

*Extracted from NASA TM-78252, Torque Equilibrium Attitude Control For Skylab Reentry, November 1976, by John R. Glaese and Hans F. Kennel.

Since $\underline{l} \cdot \underline{u}_u = \underline{l} \cdot \underline{u}_r = 0$,

$$x_{P'} = (\underline{r}_{P'} - \underline{r}_E) \cdot \underline{u}_r$$

$$y_{P'} = (\underline{r}_{P'} - \underline{r}_E) \cdot \underline{u}_u$$

The set of points $(x_{P'}, y_{P'})$ plotted conventionally forms the desired projection. Size can be altered by scale adjustments. These projections are then placed as desired. Also, the values used for d and eye separation s are arbitrary and can be adjusted for convenience or eye comfort. In real life $s \cong 65$ mm and $d \cong 250$ mm for comfortable reading; however, it may be more comfortable for d to be larger. Some initial experimentation with this technique should establish desirable settings.

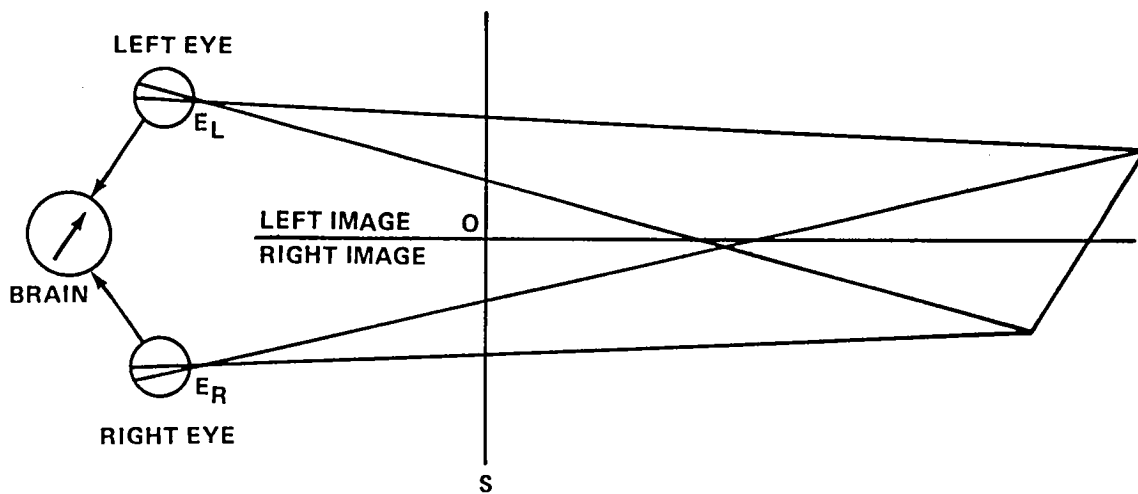

Figure A-1. Stereo projection.

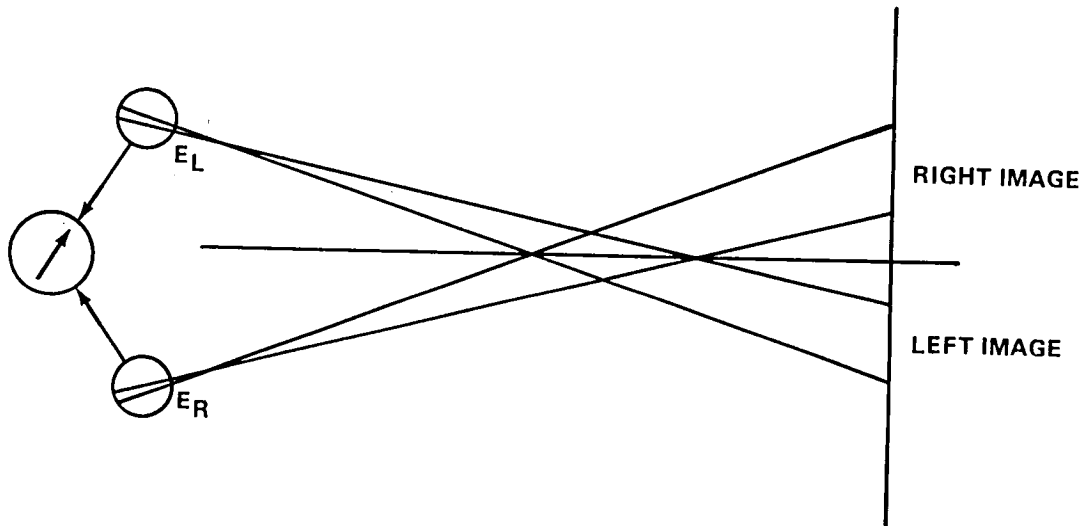

Figure A-2. Stereo reconstruction by cross-eyed viewing.

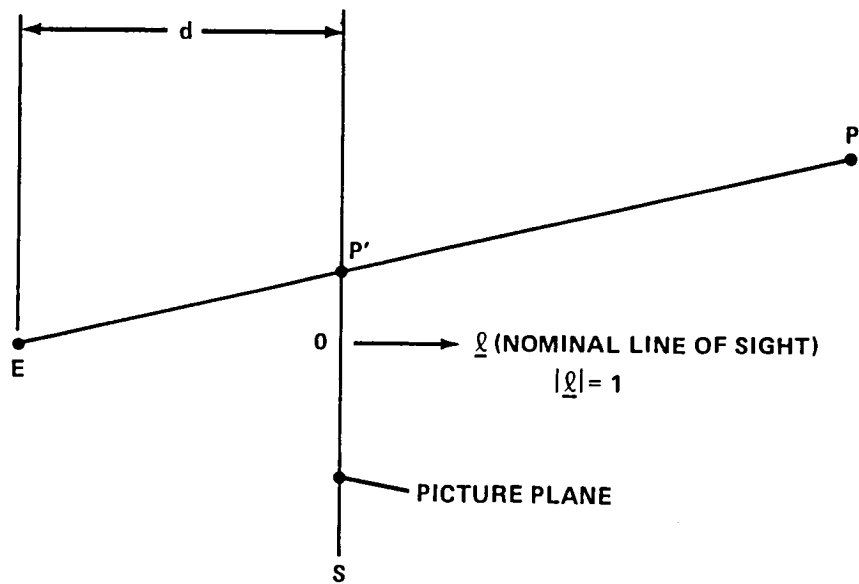

Figure A-3. Projection geometry.

Hint to Stereoscopic Viewing

Hold the stereoscopic pair at arm's length and then focus on a point about half way in-between. As an aid, try looking at your fingertip placed in the line of sight such that when your left eye is closed, your right eye sees your fingertip at the center of the left hand figure. Now, with your right eye closed, check that your left eye sees your fingertip at the center of the right hand figure. This will locate the focal point for cross-eyed stereo viewing. Now, with both eyes open, look at this point in space. At first, you will find it helpful to just stare at your fingertip. Then, in the background, you will notice three images. Try to shift your concentration from your fingertip to the middle image, which will begin to look sharp and clear (and three-dimensional). Once you have locked in on the object, remove your fingertip. With a little practice, one can easily master this technique.

1. REPORT NO. NASA TP-2575	2. GOVERNMENT ACCESSION NO.	3. RECIPIENT'S CATALOG NO.	
4. TITLE AND SUBTITLE Graphical Techniques To Assist in Pointing and Control Studies of Orbiting Spacecraft		5. REPORT DATE March 1986	6. PERFORMING ORGANIZATION CODE
		8. PERFORMING ORGANIZATION REPORT #	
7. AUTHOR(S) Leonard W. Howell and Joseph H. Ruf		10. WORK UNIT NO. M-519	
9. PERFORMING ORGANIZATION NAME AND ADDRESS George C. Marshall Space Flight Center Marshall Space Flight Center, Alabama 35812		11. CONTRACT OR GRANT NO.	
		13. TYPE OF REPORT & PERIOD COVERED Technical Paper	
12. SPONSORING AGENCY NAME AND ADDRESS National Aeronautics and Space Administration Washington, D.C. 20546		14. SPONSORING AGENCY CODE	
		15. SUPPLEMENTARY NOTES Prepared by Systems Dynamics Laboratory, Science and Engineering Directorate.	
16. ABSTRACT <p>Computer generated graphics are developed to assist in the modeling and assessment of pointing and control systems of orbiting spacecraft.</p> <p>Three-dimensional diagrams are constructed of the Earth and of geometrical models which resemble the spacecraft of interest. Orbital positioning of the spacecraft model relative to the Earth and the orbital ground track are then displayed. A star data base is also available which may be used for telescope pointing and star tracker field-of-views to visually assist in spacecraft pointing and control studies.</p> <p>A geometrical model of the Hubble Space Telescope (HST) is constructed and placed in Earth orbit to demonstrate the use of these programs. Simulated star patterns are then displayed corresponding to the primary mirror's FOV and the telescope's star trackers for various telescope orientations with respect to the celestial sphere.</p>			
17. KEY WORDS Computer graphics Earth model Field-of-view simulation Spacecraft pointing and control systems Starchart Stereo visualization		18. DISTRIBUTION STATEMENT Unclassified - Unlimited Subject Category 12	
19. SECURITY CLASSIF. (of this report) Unclassified	20. SECURITY CLASSIF. (of this page) Unclassified	21. NO. OF PAGES 18	22. PRICE A02

National Aeronautics and
Space Administration
Code NIT-4

Washington, D.C.
20546-0001

Official Business
Penalty for Private Use, \$300

BULK RATE
POSTAGE & FEES PAID
NASA
Permit No. G-27

NASA

POSTMASTER: If Undeliverable (Section 158
Postal Manual) Do Not Return
