

NASA TECHNICAL MEMORANDUM

NASA TM- 77959

DETERMINATION OF NITROGEN MONOXIDE IN HIGH PURITY NITROGEN GAS WITH AN ATMOSPHERIC PRESSURE IONIZATION MASS SPECTROMETER

Kenji Kato et al.

(NASA-TM-77959)	DETERMINATION OF NITROGEN	N86-21634
	MONOXIDE IN HIGH PURITY NITROGEN GAS WITH AN	
	ATMOSPHERIC PRESSURE IONIZATION MASS	
	SPECTROMETER (National Aeronautics and Space	Unclas
Administration)	16 p HC A02/MF A01 CSCL 07D G3/25	05799

Translation of Bunseki Kagaku (Japan Analyst), Vol. 31, No. 1, 1982, Japan, pp. 22-27

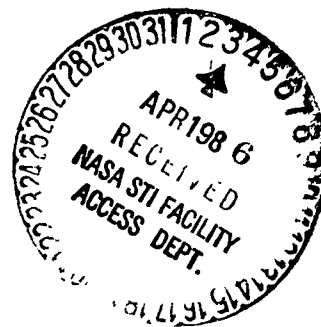

NATIONAL AERONAUTICS AND SPACE ADMINISTRATION  
WASHINGTON, D. C. 20546 NOVEMBER 1985

## STANDARD TITLE PAGE

1. Report No. NASA-TM 77959	2. Government Accession No.	3. Recipient's Catalog No.	
4. Title and Subtitle DETERMINATION OF NITROGEN MONOXIDE IN HIGH PURITY NITROGEN GAS WITH AN ATMOSPHERIC PRESSURE IONIZATION MASS SPECTROMETER		5. Report Date November 1985	6. Performing Organization Code
7. Author(s) Kenji Kato et al. (Kato, K.)		8. Performing Organization Report No.	10. Work Unit No.
9. Performing Organization Name and Address Leo Kanner Associates Redwood City, CA 94063		11. Contract or Grant No. NASW-4005	13. Type of Report and Period Covered TRANSLATION
12. Sponsoring Agency Name and Address National Aeronautics and Space Administration, Washington, DC 20546		14. Sponsoring Agency Code	
15. Supplementary Notes Translation of Bunseki Kagaku (Japan Analyst), Vol. 31, No. 1, 1982, Japan, pp. 22-27 (ISSN 0525-1931)			
16. Abstract An atmospheric pressure ionization mass spectrometric (API-MS) method was studied for the determination of residual NO in high purity N <sub>2</sub> gas. The API-MS is very sensitive to NO, but the presence of O <sub>2</sub> interferes with the NO measurement. Nitrogen gas in cylinders as sample gas was mixed with NO standard gas and/or O <sub>2</sub> standard gas, and the gas was introduced into API-MS. The calibration curves of NO and O <sub>2</sub> has linearity in the region of 0 - 2 ppm, but the slopes changed at every cylinder. Effect of O <sub>2</sub> on NO+ peak was additive and proportional to O <sub>2</sub> concentration in the range of 0 - 0.5 ppm. The increase in NO+ intensity due to O <sub>2</sub> was (0.07 - 0.13)%/O <sub>2</sub> , 1 ppm. Determination of NO and O <sub>2</sub> was carried out by standard addition method to eliminate the influence of variation of slopes. The interference due to O <sub>2</sub> was estimated from the product of the O <sub>2</sub> concentration and the ratio of slope A to slope B. The slope A is the change in the NO+ intensity with the O <sub>2</sub> concentration. The slope B is the intensity with O <sub>2</sub> concentration.			
17. Key Words (Selected by Author(s))		18. Distribution Statement Unclassified - Unlimited	
19. Security Classif. (of this report) UNCLASSIFIED	20. Security Classif. (of this page) UNCLASSIFIED	21. No. of Pages 17	22.

DETERMINATION OF NITROGEN MONOXIDE IN HIGH PURITY NITROGEN GAS WITH  
AN ATMOSPHERIC PRESSURE IONIZATION MASS SPECTROMETER

Kenji Kato et al.

1. GENERAL

The accurate concentration level of nitrogen mono-oxide remaining in the high concentration nitrogen that is widely used as the gas for dilution and the zero gas is not known today. The chemical spectral analysis has been considered one of the most accurate methods to analyze nitrogen mono-oxide; yet, this method is not good enough to accurately determine the remaining nitrogen mono-oxide. Authors have been studying the highly sensitive method to determine nitrogen mono-oxide through the means of the atmospheric pressure ionization mass spectrometry (hereinafter referred to as API-MS).(1) In API-MS, ionization is conducted within the atmosphere, and the result is led into a mass spectrometer which is maintained at an extremely high level of vacuum for detection.(2) Because the collision between ions - molecules, ions - ions, and molecules - molecules is highly active under the atmospheric pressure, both selective and highly efficient ionization will take place among mono-oxide, oxygen and others with low potential of ionization. Therefore, it is extremely accurate when compared to ordinary methods of mass spectrometry. On the other hand, influence by the coexisting substances as well as the inevitable byproducts of the reaction cause some problem. In this study, the influence of oxygen - an impurity within the test material - will be discussed while the determination of nitrogen mono-oxide and oxygen is attempted through the method

of the standard addition.

## 2. EXPERIMENTATION

### 2.1 Apparatus

The experimentation was conducted using the devices which were structured as shown in Fig. 1. The API-MS (Hitachi, M-10 model) consisting of the two-step differential exhaust device as the vacuum system and the tetrode type mass filter (UTI, model-100C) as the detection system was used as the spectrometer. The arrangement of the test material was done using the standard gas dilution device (Standard technology, SGGU-712 (0) type, accuracy of dilution compared to the full scale,  $\pm 3\%$ ). The traps (Fig. 1: 4, 6) which contain molecular sieve (13X) shaped like a pellet, 1/16 inches in diameter, were used to remove water and nitrogen mono-oxide from the test material. The entire tubing, with the exception of the traps made of glass, is made of stainless steel (SUS 316); the receiving part is made of the non-oxygen copper packing (CAJON, VCR receiving); the valves are made of CAJON, SS-4H in order to minimize leakage.

### 2.2 Test material and the standard gas

As the test material, high purity nitrogen gas contained in a cylinder (Nippon Sanso, S grade) was used; as the standard gas, nitrogen balance nitrogen mono-oxide standard gas contained in a cylinder (Nippon Sanso, 971 ppm) and oxygen standard gas (Nippon Sanso, 1050 ppm) were used.

### 2.3 Operation and condition

By diluting the nitrogen mono-oxide and the oxygen standard gas with the high purity nitrogen gas using the standard gas dilution device, the test gas each of which is mixed with 0 - 2 ppm of nitrogen mono-oxide and oxygen was prepared.

In the measurement of the background and the oxygen measurement line, the one without any trap and the one with two traps were measured. In the measurement of the nitrogen mono-oxide measurement line, the one without any traps and the one with a trap (Fig. 1, 4) were measured. In 3.5 and 3.6, no traps were used.

The condition of the measurement, unless specifically mentioned otherwise, was as follows: Temperature of the ion source, 60 degrees C; the drift voltage between the first and the second gaps, 20 V; the flow volume of the test material, 11/ min; discharge voltage, 0.5 micro amp; the position of the damper of the mass filter, at the lowest position; speed of the scanning, approximately 0.7 AMU/s; the recorder chart speed, 60 mm/min. (1)

In the determination of nitrogen mono-oxide in 3.6, three measurement lines - the concentration of nitrogen mono-oxide (0 to 0.06 ppm) vs. NO<sup>+</sup> ion intensity, the concentration of oxygen (0 to 0.4 ppm) vs. NO<sup>+</sup> ion intensity, and the concentration of oxygen (0 to 0.08 ppm) vs. O<sub>2</sub><sup>+</sup> ion intensity - were prepared and the calculation was conducted according to the following sub-paragraphs 2.4 and 2.5.

Fig. 1

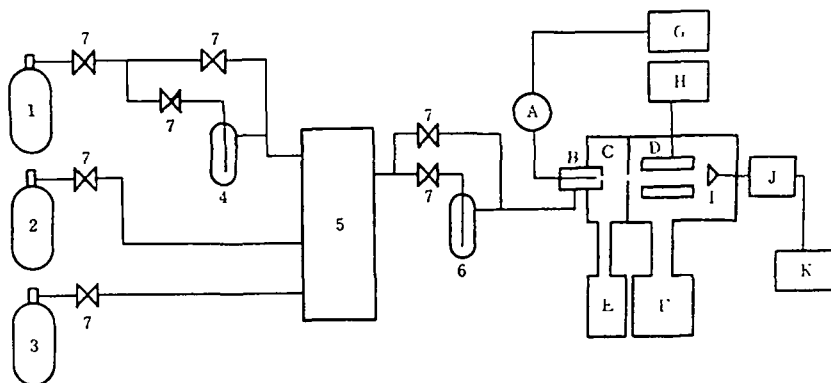

Fig. 1 The blockdiagram of the apparatus for the determination of nitrogen mono-oxide and the scheme of the atmospheric ionization mass spectrometer

1 High purity nitrogen gas cylinder, 2 Nitrogen balance nitrogen mono-oxide standard gas (971 ppm), 3 Nitrogen balance oxygen standard gas (1050 ppm), 4, 6 Molecular sieve traps, 5 Standard gas diluter, 7 Bellows valves, A Micro ammeter, B Atmospheric pressure ionization source with the corona discharge electrode, C Drift area, D Q-pole mass filter, E Rotary pump, F Diffusion pump and rotary pump, G High voltage power supply, H Q-pole power supply, I Electron multiplier, J Amplifier, K Recorder

## 2.4 Data processing

The peak height of each mass number from the spectrum recorded on the chart of the recorder is read, and the height of the reading is called the peak intensity. The ratio of the peak intensity in relationship to the total sum of the peak intensity within the spectrum by one scanning shown in % is called the relative intensity. If the term intensity is mentioned, it means both the peak intensity and the relative intensity.

The measurement was repeated 4 - 7 times under one condition. The data which are far apart were thrown out, and the number of the data was fixed at  $n$  each ( $n = 3, 5$ ). The average figure excluding one each ( $n - 1$  each) is prepared in the number of  $n$  each, and each average figure was made to be the new set of data. Using these data, the incline of the measurement line, the intercept of  $x$  and the errors between

the two are obtained through the minimum involution. (3) The error is obtained strictly from the fluctuation of the measurement figures without considering the accuracy of the measurement devices as well as the method of the measurement. The error indicates the limit (of the dependability) of the 95 % dependability.

## 2.5 Calculation of influence by concentration and oxygen

Density of nitrogen mono-oxide and oxygen was obtained from the intercept of x of the measurement line. Furthermore, the figure which has the influence of oxygen subtracted according to the following formula was also obtained for nitrogen mono-oxide.

$$I = C_o \times A_{O_{NO}} / A_{NO} \quad \dots \quad (1)$$

$$dI = I \times \left\{ (dC_o / C_o) + (dA_{O_{NO}} / A_{O_{NO}}) + (dA_{NO} / A_{NO}) \right\} \quad \dots \quad (2)$$

I and dI indicate the intensity of the NO+ ions which increase by the presence of oxygen and its errors; Co and dCo indicate the concentration of oxygen and its errors; Aono and dAono indicate the changes in the incline of the measurement line of NO+ ion intensity made by adding oxygen; Ano and dAno indicate the incline of the measurement line of nitrogen mono-oxide and its errors.

## 3. RESULTS AND CONSIDERATION

### 3.1 Background

The API-spectrum of high purity nitrogen gas is shown in Fig. 2. The peak of [m/z = 30 and 32] is considered

to be  $\text{NO}^+$  and  $\text{O}_2^+$ . Although  $^{15}\text{N}_2$ ,  $\text{C}_{18}\text{O}$  and  $^{13}\text{C}^{17}\text{O}$  also have the peak [ $m/z = 30$ ], expected intensity is extremely low. By letting through the trap, the intensity of  $\text{NO}^+$  decreased considerably, but it did not completely disappear. The peak of [ $m/z = 36$  and  $37$ ] is considered to be  $\text{H}_3\text{O}^+\text{OH}$  or  $\text{NH}_4^+\text{H}_2$ ,  $\text{H}+(\text{H}_2\text{O})_2$ . It was used as the measurement standard to check the volume of water within the test material. (4)(5)

The peak relative intensity of  $\text{NO}^+$  and  $\text{O}_2^+$  in Fig. 2 was 0.06 % and 1.3 %. The ones which was let through the trap recorded 0.02 % and 0.34 %. The noise level of the two was approximately 0.004%.

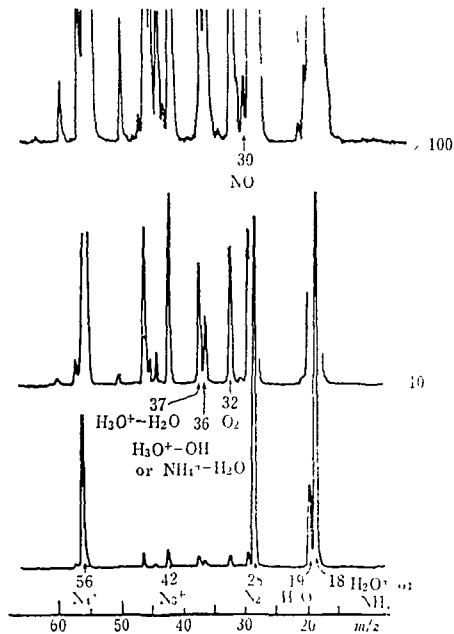

Fig. 2 Mass spectrum of high purity nitrogen gas without any trap  
 $\text{NO}^+$  and  $\text{O}_2^+$  are observed at  $m/z$  30, 32

### 3.2 The measurement line of nitrogen mono-oxide

When the relative intensity is used, the measurement



line of nitrogen mono-oxide in the electric discharge of 0.5 to 2 micro A showed an excellent linear characteristic within the concentration region of 0 - 2 ppm; however, the same measurement in the electric discharge of 5 micro A showed a slight convex curvature. As the electric discharge was increased, the relative intensity showed significant decrease. The main cause of this is due to the increase in the intensity of the peak other than NO+. Yet, the peak intensity of NO+ itself showed some decline. It is assumed that the cause of the above condition is as follows: The volume of NO+ ions does not increase too rapidly in spite of increase in the electric discharge even if the ionization ratio of nitrogen mono-oxide is close to 100 %. Also, the ion transmission ratio up to the detection system is lowered by the impact among ions because the total volume of ions is significantly increased.

The sensitivity toward nitrogen mono-oxide (change in relative intensity of NO+ per nitrogen mono-oxide, additive, concentration, 1 ppm) at the electric discharge of 0.5 micro A among those which (1) were passed through the trap (Fig. 1, 4) measured (6.6 - 7.2) % / NO, 1 ppm, (average figure 6.94 % / NO, 1 ppm, standard deviation 0.29 % / NO, 1 ppm, sample number 3), and among those which (2) were not passed through the trap measured (5.8 - 7.2) % / NO, 1 ppm (average figure 6.4 % / NO, 1 ppm, standard deviation 0.6 % / NO, 1 ppm, sample number 9). Because of the extensive change

in sensitivity, the measurement line method is unsuitable; however, it is possible to conduct the determination by the standard addition method because of its excellent linear characteristics.

The limit of the detection, considering the noise in the spectrum shown in Fig. 2, is about (1 - 1.5) ppb assuming that  $S/N = 2$ .

The measurement line of nitrogen mono-oxide obtained from the peak intensity instead of the relative intensity showed a slight convex curvature.

### 3.3 Oxygen measurement line

The measurement line by the relative intensity of  $O_2^+$  ion when oxygen is added in the concentration of 0 - 2 ppm showed a straight line within the electric discharge (0.1 - 5) micro A. The relative intensity declined as the electric discharge was increased. The reason for the decline in the relative intensity is considered to be the same as the case of nitrogen mono-oxide. Yet, the peak intensity of  $O_2^+$  ion shows different result depending upon the condition of the experimentation. Some decline was observed when the trap was used, while some increase was observed when the trap was not used. The reason for the fluctuating result depending upon the condition of the experimentation may be due to the influence of water. Further study is needed to determine the exact cause when the purpose of the experimentation is to determine the volume of oxygen.

The sensitivity toward oxygen (change in relative intensity of  $O_2^+$  per oxygen, additive, concentration 1 ppm) at the electric discharge of 0.5 micro A among those which (1) were passed through the both traps measured (12 - 15) % /  $O_2$  1 ppm (average figure 12.9 % /  $O_2$  1 ppm, standard deviation 1.0 % /  $O_2$  1 ppm, sample number 7), and among those which (2) were not passed through the both traps measured (8.6 - 12.8) % /  $O_2$  1 ppm (average figure 10.5 % /  $O_2$  1 ppm, standard deviation 1.5 % /  $O_2$  1 ppm, sample number 5 ). As shown above, influence by water is detectable, but no influence by the flow volume [ (0.1 - 1) l/ min] was hardly detected. The detection limit of oxygen from the spectrum noise of Fig. 2 under the condition of  $S/N = 2$  was (0.9 - 0.5) ppb, a little better than nitrogen mono-oxide.

The measurement line of oxygen obtained from the peak intensity showed a slight convex curvature.

### 3.4 Influence of oxygen on nitrogen mono-oxide

#### 3.4.1 Influence upon the sensitivity of nitrogen mono-oxide

The result of the measurement of the measurement line of nitrogen mono-oxide which was added with 0, 0.2, 0.5 and 2 ppm of oxygen revealed that the linear characteristics were excellent with the exception of the oxygen concentration 2 ppm. It is assumed that the measurement through the standard addition method is possible even in the case where oxygen in the volume of 0.5 ppm

coexists.

### 3.4.2 Influence of oxygen on intensity of NO+ ion

Fig. 3 shows changes of the relative intensity of NO+ as oxygen is added in the volume of 0 - 2 ppm. The change in the relative intensity of NO+ per oxygen additive concentration 1 ppm under the condition of the electric discharge 0.5 micro A was (0.072 - 0.13) % (average figure 0.11 %, average deviation 0.02 %, number of samples 10). This influence tended to increase as the electric discharge and the test material flow volume showed some increase; however, it was not clear whether or not the passage of the traps made any influence. Tab. 1 shows the influence of oxygen upon nitrogen mono-oxide, sensitivity of oxygen and NO+ determined by each electric discharge as the same experimentation under the same condition except the electric discharge was continuously conducted.

As the increase in relative intensity of NO+ when oxygen in the volume of 1 ppm is added is converted into the concentration of nitrogen mono-oxide using Table 1, the result showed 24 ppb, 36 ppb, 57 ppb, 107 ppb and 192 ppb.

Table 1 Effect of the discharge current

Discharge current/ $\mu$ A	NO sensitivity/ (%/NO, 1 ppm)	O <sub>2</sub> sensitivity/ (%/O <sub>2</sub> , 1 ppm)	Influence of O <sub>2</sub> on NO intensity/ (%/O <sub>2</sub> , 1 ppm)
0.2	6.8	17.4	0.17
0.5	4.9	14.8	0.18
1	3.5	12.5	0.20
2	2.1	9.4	0.22
5	1.2	6.1	0.23

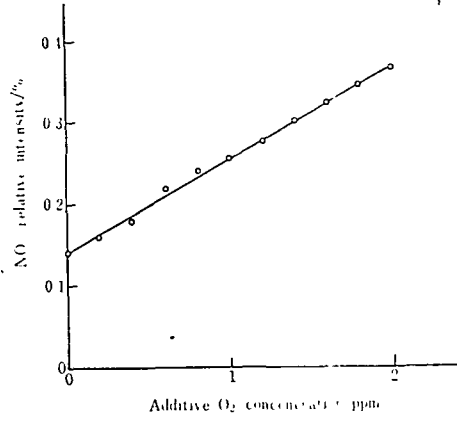

Fig. 3 Calibration curve of NO+ relative intensity vs concentration of additive oxygen

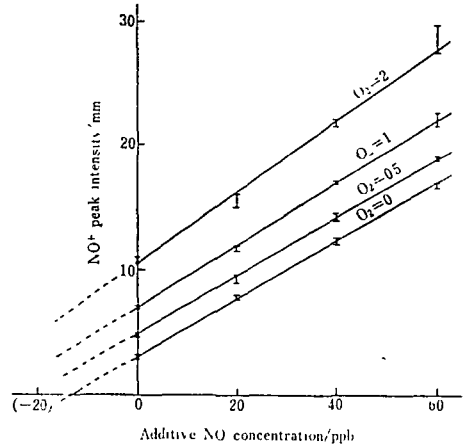

Fig. 4 Calibration curves of nitrogen mono-oxide in low concentration region with oxygen of various concentration

### 3.5 Examination at the low concentration region

Fig. 4 shows the measurement line of nitrogen mono-oxide, additive concentration of 0 - 0.06 ppm (when it is not passed through the traps). The vertical axis indicates the peak intensity, and it is determined to be a straight line in low concentration region as shown in Fig. 4. It is apparent from Fig. 4 that there is hardly no change in the incline of the measurement line at the oxygen additive concentration of 0 - 0.5 ppm. Although not shown in Fig. 4, the result was the same as the relative intensity was shown in the vertical axis.

As explained above, the influence of oxygen, if the

**ORIGINAL PAGE IS  
OF POOR QUALITY**

concentration of nitrogen mono-oxide is low and the same of oxygen is below 0,5 ppm, merely amounts to the parallel shifting of the measurement line. Accordingly, the influence of oxygen can be removed simply by calculating and subtracting its contribution toward the nitrogen mono-oxide measurement volume by separately measuring the oxygen concentration.

3.6 The result of the measurement of nitrogen mono-oxide through API-MS

Based on the result of 3.2 - 3.5, measurement of nitrogen mono-oxide within high purity nitrogen gas contained in a cylinder was conducted. The result is shown in Tab. 2. Lower level electric current was found to be more suitable as electric discharge because it has higher sensitivity of nitrogen mono-oxide and oxygen and it has less influence by oxygen as shown in Tab. 1. Yet, considering the stability of electric discharge, it was decided to be 0.5 micro A.

Table 2 Analytical results of nitrogen mono-oxide  
in high purity nitrogen gas

Cylinder number	Concentration of nitrogen mono-oxide/ppb $C_{NO}$	Concentration of oxygen/ppb $C_O$	Influence of oxygen/ppb $I, dI$	Corrected concentration of nitrogen mono-oxide/ppb $C_{NO-f}$
1	13.1±4.3 (11.0±4.3)	55±5 (50±4)	0.8±0.5 (0.6±0.5)	12.3±4.8 (13.1±4.8)
2	10.3±3.0 (11.2±2.5)	16±5 (52±3)	1.4±0.7 (0.9±0.6)	9.0±3.8 (10.3±3.2)
3	13.9±3.6 (13.4±3.6)	47±7 (49±7)	0.7±0.3 (0.6±0.3)	13.2±3.9 (12.8±3.9)
4	12.3±1.0 (12.7±1.2)	56±3 (55±5)	0.7±0.1 (0.6±0.1)	11.6±1.1 (12.0±1.4)
5	12.3±2.6 (12.1±2.8)	53±11 (51±9)	0.8±0.3 (0.7±0.2)	11.5±2.8 (11.4±3.1)

Parenthesized values are calculated from peak intensities and unparenthesized values are from relative intensities respectively. Confidence limits of 95% are also indicated with "±" signs.

The result of the measurement showed almost the same measurement between the method of the relative intensity and

the method of the peak intensity. From this result, we can safely conclude that the measurement can be conducted using the peak intensity method at the low concentration region. Particularly for those test material with abundance of water, there are peaks of which intensity is not quite stable presenting some problems in the case of the relative intensity method. In the case such as this, the peak intensity method is considered to be superior to the method of the relative intensity.

#### 4. CONCLUSION

The limits in the measurement of the nitrogen mono-oxide through the API-MS method can be made far less by making the time constant of the measurement system greater or through integration of the measurement system; however, the limits of the measurement as they stand today seem to be sufficient enough for the measurement of the remaining nitrogen mono-oxide within high purity nitrogen gas.

The result of the measurement of nitrogen mono-oxide compared to the figure stated in the data plate of the cylinder (NO<sub>x</sub>, below 0.01 ppm) appears to be a little too high. Since there is no other measurement figures that can be compared at the present moment, we are presently examining the feasibility of the comparison with the figures obtained through the higher derivative spectral absorptiometry or other methods. The result of the preliminary experimentation indicates that the above described higher derivative spectral

absorptiometry tends to result in almost the same or a little lower figures.

The accuracy of this method largely depends upon the accuracy of the standard gas and the standard gas dilution device. For example, the accuracy of dilution of the standard dilution device converted into the concentration of the gas is  $\pm 3$  ppb, and the fluctuation of this extent is considered to cause changes in the result of the final measurement. When the condition is suitable, the accuracy of  $\pm 1$  ppb can be expected at the limits of dependability within 5 %.

As for the measurement figures of oxygen, its true purpose is to make necessary correction in the measurement of nitrogen mono-oxide, and many problems such as the influence of water or the mixing of oxygen from the air through the pipe line system remain to be solved.

#### Bibliography:

- 1) Kojima Masuo, Tomita Hiroshi, Sato Noritaka, Kato Kenji: Selected articles from the Nippon Bunseki Kagakukai 29th Meeting , p. 616 (1980).
- 2) Kanbara Hideki, Bunseki , 1979, 848.
- 3) Tanaka Genichi, Tokei Kaiseki , (1973), (Maruzen).
- 4) H. Kambara, I. Kanomata, Anal. Chem. , 49, 270 (1977).
- 5) H. Kambara, Y. Mitsui, I. Kanomata, Anal. Chem. , 51, 1447 (1979).