

FAILURE CRITERION OF GLASS FABRIC REINFORCED PLASTIC LAMINATES

Osamu Haga, Noriyuki Hayashi and Kazuo Kasuya

Translation of "Glass cloth sekiso kyoka plastic no hakai kijun", Japan Society of Materials Science, Journal, Vol. 25, No. 273, June 1976, pp. 516-520

(NASA-TM-88406) FAILURE CRITERION OF GLASS FABRIC REINFORCED PLASTIC LAMINATES (National Aeronautics and Space Administration) 11 p HC A02/MF A01 CSCL 11D	N86-23657
G3/24	Unclas 06003



by Osamu Haga,** Noriyuki Hayashi** and Kazuo Kasuya***

Tension, compression and combined tension-compression biaxial tests were performed on three types of glass fabric reinforced plastic laminates, and the applicability of an interaction formula was investigated. Based on these results a new combined tension-compression biaxial failure criterion have been derived. The results obtained are as follows ;

(1) The interaction formula can be used practically as the uniaxial failure criterion of glass fabric laminates when it is transformed into the equation containing tensile or compressive strength in the direction having an angle of 45 degree to one of the anisotropic axes.

(2) In the case of closely woven plain fabrics, the interaction formula can be applied as the combined tension-compression biaxial failure criterion, but in the case of coarsely-woven plain fabrics, the calculated values do not agree well with the experimental results.

(3) The values calculated according to the new combined tension-compression biaxial failure criterion agree fairly with the experimental results. When this criterion is applied to the case of uniaxial loading, the formula becomes the same as that of the uniaxial failure criterion given in (1).

(Received Sep. 22, 1975)

1. Introduction

In general, there are unidirectional fiber reinforced plastics in which fiber is arranged in one direction, laminated in which the unidirectional fibers are laminated perpendicularly or obliquely and laminates which are laminated with fabrics, such as glass cloth, containing a plastic matrix in continuous fiber reinforced plastics. Many theoretical and experimental studies concerning yield and failure of the former material by combined stress have been accomplished (Reference (1) to (4)) but there are few studies directly concerning glass cloth laminate of the latter.

The strength characteristics of glass cloth laminates are different from those of unidirectional reinforced plastic or its laminates; it seems to be from the influence of the wave condition of woven fabrics, woven conditions and twined condition of fiber. The authors are studying biaxial stress-failure criterion of laminated reinforced plastics made of glass fiber and in this report, the results of experimental studies concerning failure criterion under tension-compression biaxial stress conditions are reported.

* Received Sept. 22, 1975

** Official member, The engineering dept. of Chiba University, Yayoi-cho, Chiba

*** The engineering dept. of Chiba University, Yayoi-cho, Chiba

**** Numbers in margin indicate foreign pagination.

2. Failure Criterion

2.1. Failure criterion of uniaxial tension and uniaxial compression

There is a report which tried to make tension failure criterion of glass cloth laminate reinforced plastic from the characteristics of the content materials (Reference (5)) but it seems to be difficult to generalize for glass cloth laminates with differently woven cloth because the report does not consider the influence of the weave. However, it would be very difficult to consider the influence of weave on strength. Thus the authors adopted a criterion which is a little modified from the Interaction formula (Reference (6)) proposed by Norris by considering the strength of composite material including the influence of weave as the base. For the coordinate system shown in Fig.1, the stress $\sigma(\theta)$ in the X direction with angle θ against the anisotropic axis L can be written as equation (1) by applying the coordinate conversion rule to the interaction formula.

$$\sigma(\theta) = \frac{F_L F_T S_{LT}}{\sqrt{1 + (F_L/S_{LT})^2 + (F_T/S_{LT})^2 + F_L F_T S_{LT}^2}} \quad (1)$$

According to equation (1), when θ is close to 45° , the stress does not match the actual measured value thus an equation which uses the tensile strength or compressive strength F_{45° at $\theta = 45^\circ$ instead of the shear strength S_{LT} is conducted, i.e., $\theta = 45^\circ$ is applied to the equation (1) and solve S_{LT} then apply it to equation (1) again. /17

$$\sigma(\theta) = \frac{1}{\sqrt{(l^2 - m^2) \left(\frac{l^2}{F_L^2} - \frac{m^2}{F_T^2} \right) + \left(\frac{2lm}{F_{45^\circ}} \right)^2}} \quad (2)$$

In the case that two materials which have the same strength are laid up in different ply orientation, equation (2) can be simplified as shown below by applying $F_L = F_T = F$.

$$\sigma(\theta) = \frac{1}{\sqrt{\left(\frac{1}{F} \cos 2\theta \right)^2 + \left(\frac{1}{F_{45^\circ}} \sin 2\theta \right)^2}} \quad (2')$$

From equation (2) or (2)', if tensile or compressive strength in the direction of the anisotropic axis and the direction of 45° from the axis is given, the failure strength of the arbitrary angle between the axis can be calculated.

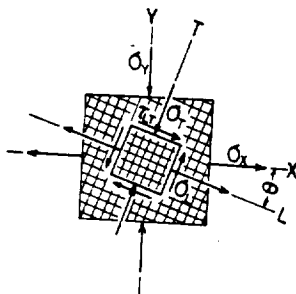

Fig. 1. Coordinate system of the glass fabric reinforced plastic laminates.

2.2 Tension-compression combination biaxial failure criterion

The previous report (Reference (7)) studied the failure mode of the biaxial test results and the failure criterion was conducted from the results. In this report, the authors revised them and assumed that failure occurs under the following conditions.

(1) The condition in which σ_x or σ_y reaches uniaxial tensile strength $\sigma_{t(\theta)}$ or uniaxial compressive strength $\sigma_{c(\theta)}$ expressed in equation (2), i.e.

$$\sigma_x = \sigma_{t(\theta)} \quad \text{OR} \quad \sigma_y = \sigma_{c(\theta)} \quad (3)$$

(2) The condition in which the shear stress τ_{LT} reaches the shear strength S_{LT} of the composite material. Since this study deals with tension-compression combination biaxial case, the relationships between σ_x and σ_y when failure occurs is as follows.

$$\sigma_x - \sigma_y = \frac{S_{LT}}{lm} \quad (4)$$

(3) By considering the influence of both perpendicular stress against the anisotropic axis L and T, and the shear stress, the combined stress which is from $\sigma_e = \sqrt{\sigma^2 + \tau^2}$ (Reference (8)) was considered when σ_e reaches the uniaxial tensile strength $\sigma_{t(\beta)}$ or the uniaxial compression strength $\sigma_{c(\beta)}$ in the direction which corresponds to the direction of $\tan \beta = \tau/\sigma$, the following equations can be obtained where σ_L and σ_T is the combined stress against the other orientation axis L and T and their directions are β_L and β_T and σ_x/σ_y is written as $-\phi$.

$$\left. \begin{aligned} \sigma_{eL} &= \sqrt{\sigma_L^2 + \tau_{LT}^2} = \sigma_x \sqrt{l^2 + \frac{m^2}{\phi^2}} \\ \sigma_{eT} &= \sqrt{\sigma_T^2 + \tau_{LT}^2} = \sigma_x \sqrt{m^2 + \frac{l^2}{\phi^2}} \end{aligned} \right\} \quad (5)$$

$$\left. \begin{aligned} \beta_L &= \tan^{-1} \frac{\tau_{LT}}{\sigma_L} = \tan^{-1} \frac{(\phi+1)lm}{\phi l^2 - m^2} \\ \beta_T &= \tan^{-1} \frac{\tau_{LT}}{\sigma_T} = \tan^{-1} \frac{(\phi+1)lm}{\phi m^2 - l^2} \end{aligned} \right\} \quad (6)$$

From equation (2), (5) and (6)

$$\sigma_x = \frac{\sigma_{t(\beta_L)}}{\sqrt{l^2 + \frac{m^2}{\phi^2}}} \quad \text{OR} \quad \sigma_x = \frac{\sigma_{c(\beta_T)}}{\sqrt{m^2 + \frac{l^2}{\phi^2}}} \quad (7)$$

$\sigma_{t(\beta_L)}$ and $\sigma_{c(\beta_T)}$ are the values obtained by applying β_L and β_T of equation (9) to equation (5). The authors assumed that failure occurs at the minimum stress of equations (3), (4) and (7).

3. Test method

Three types of woven glass cloth were used. Fig.2 shows the weave of the glass cloth. (1) is a fabric with a little twisted wide roving cloth. (2) is a closely woven fabric with thin fiber. (3) is a fabric with the same thin fiber as (2) but is coarsely woven. In this report these fabrics (1), (2) and (3) are called

"Roving glass cloth", "Close plain woven glass cloth" and "Coarse plain woven glass cloth". The test specimens used non-saturated polyester as a matrix resin and were prepared by hand layup method. B.P.O 1.5 wt% was used as a hardener and the hardening condition was 90 °C for 4 hours. The specimens were laid up keeping 90 degrees of the ply orientation of each ply so that the strength of the laminates in the two directions is the same.

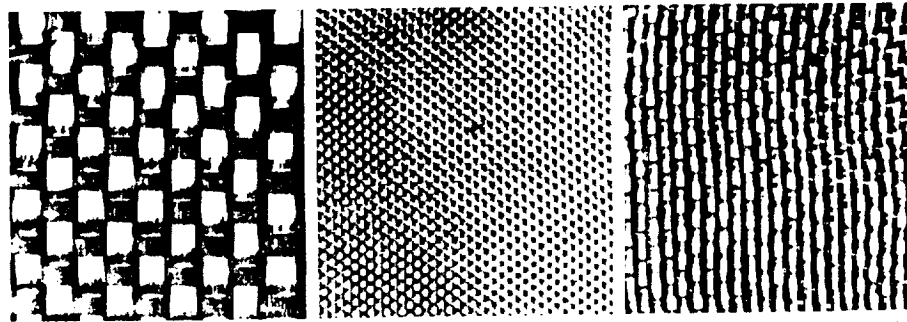

1- Roving glass cloth 2- Close plain woven glass cloth 3- Coarse plain woven glass cloth

Fig. 2. Types of glass fabric.

ORIGINAL PAGE IS
OF POOR QUALITY

/18

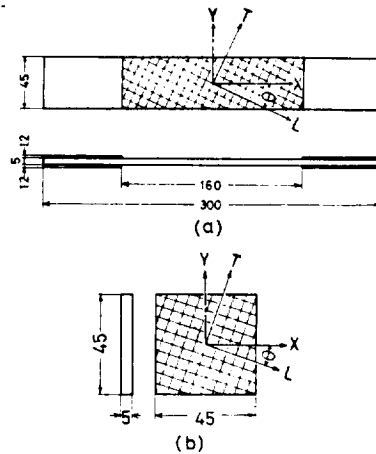

(a) Uniaxial tension and biaxial tension-compression test specimen
(b) Uniaxial compression test specimen

Fig. 3. Dimensions of test specimen.

The dimensions of the specimens and the coordinates of the anisotropic axis are shown in Fig.3. (a) is the specimen for uniaxial tension test and combined biaxial test and (b) is the specimen for uniaxial compression. The dimensions of the specimen for the uniaxial test were determined as shown in Fig.3(b) after verifying that buckling failure does not occur in the preliminary tests.

The details of the tension-compression biaxial test equipment have been described in the previous report (Reference (7)).

4. Test results and considerations

Fig.4 (a) to (c) and Fig.5(a) to (c) show the relationships between the orientation angle θ which is the angle between one anisotropic axis and the direction of applied tension or compression and failure stress. All of the test specimens were prepared to have equal strength in the elastic axis, thus the equation (2)' was applied. In the compression tests, the test results show large scatter thus 4 to 5 of the specimens were tested and the figure shows the maximum and the minimum stress.

The calculation and the test results seem to match well and in the case of compression, the failure stress of the specimens which have low fiber content and of the roving cloth is not influenced by the ply orientation angle θ and the failure stress was almost constant. Thus it was found that the equation (2)' matches the actual results well for uniaxial failure criterion. In general, the test methods for equation (2)' (or Equation(2)) have not been established and shear strength of which measurement stress is scattered is not included. Thus the equation is expressed only with tensile strength or compressive strength which are easy to obtain by test so it is practical.

From the equation (2) or (2)', physical meaning of failure can not be obtained. The failure mechanism of glass cloth laminates differs from tension or compression failure of uniaxial reinforced plastic. The failure criterion having physical meaning seems to be expressed with various unique factors of glass fiber fabric besides fiber content and layer strength such as tension, compression and shear in the fiber matrix. Therefore, it would be difficult to conduct such a criterion.

For tension-compression biaxial criterion, when the interaction formula, mentioned in the previous report (Reference (7)) using F_t for tensile strength, F_r for compressive strength and S_{LT} for shear strength was applied to the coarse plain woven glass cloth laminates, the result did not match the test results well. As can be found from equation (1), the uniaxial strength has discrepancy with a different value by considering the condition of uniaxial tension as a special case of combined biaxial tension or a special case of combination of tension and compression. But the interaction formula is a very simple formula so it is convenient in practical use.

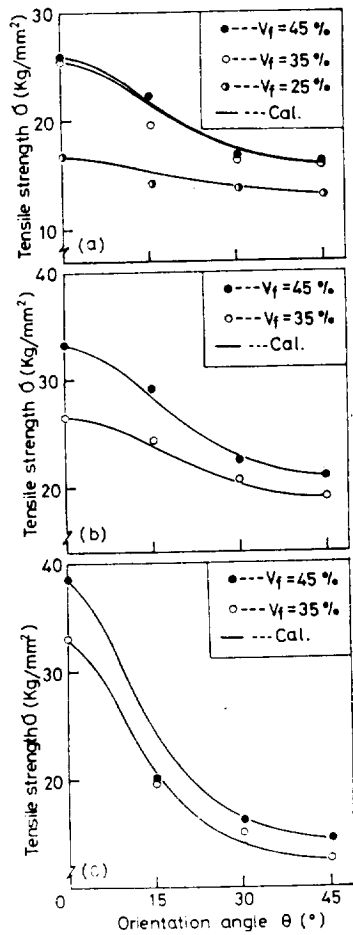

- a. Coarse plain woven glass cloth
- b. Close plain woven glass cloth
- c. Roving glass cloth

Fig. 4. The comparison of uniaxial failure criterion with the experimental results under uniaxial tensile load.

Here, the authors applied the interaction formula to the close plain woven glass cloth laminates and the roving glass woven laminates. Fig.6 (a) to (d) show comparison of the calculation results and test results. As shown in the figure, both match pretty well. Thus it seems to be able to be used as failure criterion for /19
close plain woven glass cloth and roving glass cloth of which fibers are woven closely.

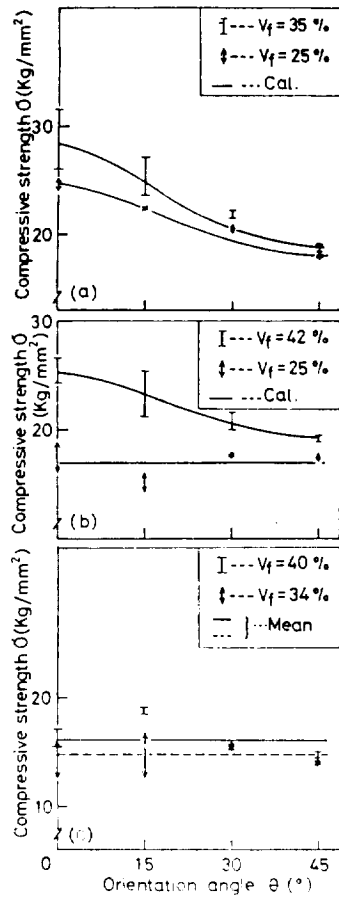

Fig. 5. The comparison of uniaxial failure criterion with the experimental results under uniaxial compressive load.

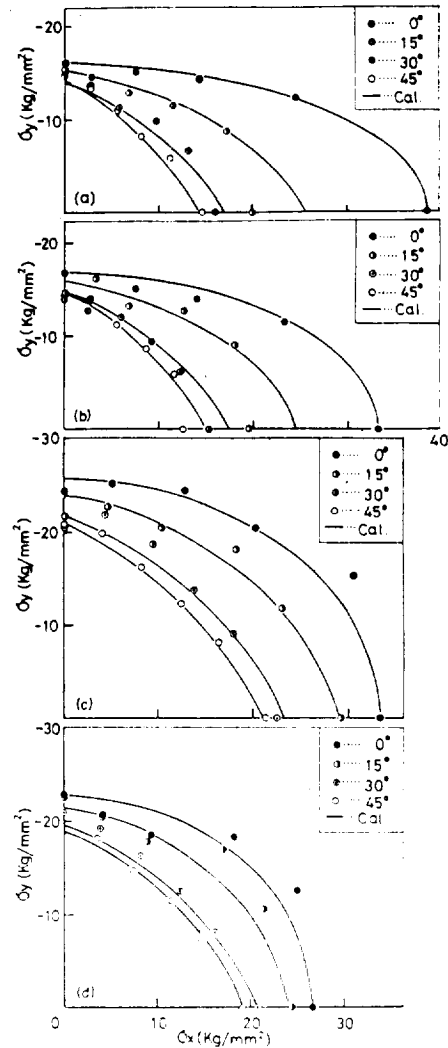
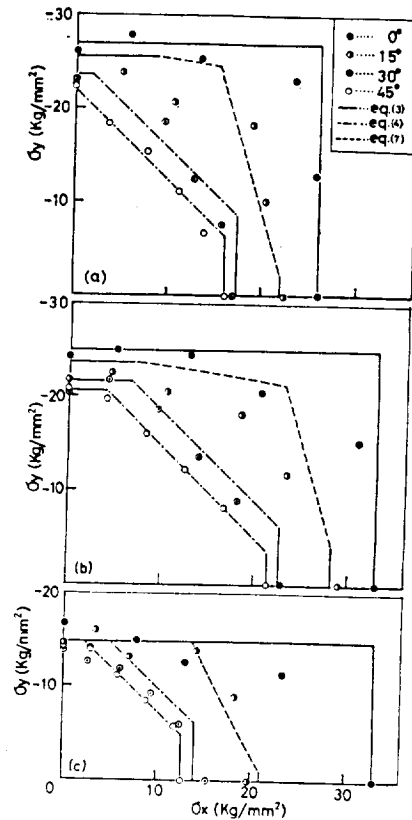

Fig. 6. The comparison of calculated values by interaction formula with the experimental results under biaxial loading.

The comparison of calculation results of equations (3), (4) and (7) which were conducted as new failure criteria and the test results is shown in Fig.7(a) to (c). In the case of the coarse plain woven glass cloth, the calculation results and the test results match well but in the case of the roving glass cloth and the close plain woven glass cloth which have wide weave or close weave the results did not match well. It may be from the interactive influence of the stress components σ_L and σ_T in the L and T direction in the case that $\theta = 0^\circ$. When compressive strength is low, this tendency occurred more. Compressive stress reduces in order with the coarse plain woven glass cloth, the close plain woven glass cloth and the roving glass cloth and this coincides with the order of weave roughness, and thickness of the fiber, i.e., the order of weave of the fiber which composes the fabrics. Thus it seems that the fabric with larger weave has larger mutual interference of σ_L and σ_T .

Equation (4) which expresses failure by shear stress in all of the cases coincided well with the test results. Under pure shear stress condition between the anisotropic axis (for example, the place where $\theta = 45^\circ$ and $\phi = -1$ in Fig.8(a)), shear failure occurs easily at 1/3 of tensile strength and about 1/2 of compressive strength in fiber direction for the roving glass cloth and the close plain woven glass cloth. Therefore, it should be given enough attention.

The trend from equation (7) which expresses mutual interference of the perpendicular stress and the shear stress seems to match with the test results and in this case, also mutual influence of the components of the perpendicular stress in the L and T direction.



(a) Coarse plain woven glass cloth, $V_f = 35\%$
 (b) Close plain woven glass cloth, $V_f = 35\%$
 (c) Roving glass cloth, $V_f = 35\%$

Fig. 7. The comparison of failure criterion, eqs. (3), (4), (7), with the experimental results under biaxial loading.

5. Conclusions

Tension, compression and tension-compression biaxial tests were performed on three types of glass fiber fabric reinforced plastic laminates and the applicability of the generally used interaction formula was studied. Based on the results, new tension-compression combination biaxial failure criteria were conducted. The following conclusions were obtained.

- (1) The interaction formula which is transformed into the formula for tensile or compressive strength instead of shear strength in the direction of 45° to one of the anisotropic axis can be used as an uniaxial failure criterion for glass cloth laminates.
- (2) The interaction formula can be applied to closely woven plain fabric laminates as a tension-compression combination biaxial failure criterion but for coarsely woven plain fabric laminate, the formula does not agree with the test results.
- (3) The authors studied the failure modes and a new tension-compression combination biaxial failure criterion was conducted. The tendency of calculation results and the test results coincided and when this criterion is applied to the case of uniaxial loading, the formula is the same as the formula used for tension or compression strength instead of shear strength in the direction of 45° to the anisotropic axis.

At last, the authors cordially thank Professor Hidekatsu Shiratori and Assistant Professor Kozo Ikegami of the Precision Engineering Institute of Tokyo Technical College for their assistance throughout this study.

Lecture given at the 24th science council of the Japan Material Society on May 20, 1975)

References

- (1) Koichi Ohira : Kyudai Kogaku Shuho, 42,454 (1969)
- (2) Kozo Kawada : Zairyo, 20,881 (1971)
- (3) Puppo, A.H. and H.A. Evensen, AIAA Journal, 10, 468(1972)
- (4) Wu, E.M. and J.K.Scheublein, ASTM STP, 546, 188 (1974)
- (5) Sadao Amijima and Harunori Konami : Zairyo, 22, 1017 (1973)
- (6) Norris, C.B. : Forest Products Laboratory Report, 1816 (1962)
- (7) Osamu Haga, Noriyuki Hayashi and Kazuo Kasuya : Zairyo, 24, 776 (1975)
- (8) Hidekatsu Shiratori, Kozo Ikegami and Toshio Hattori : Zairyo, 22, 1802 (1973)

ORIGINAL PAGE IS
OF POOR QUALITY

STANDARD TITLE PAGE

1. Report No. NASA TM- 88406		2. Government Accession No.		3. Recipient's Catalog No.	
4. Title and Subtitle FAILURE CRITERION OF GLASS FABRIC REINFORCED PLASTIC LAMINATES				5. Report Date APRIL 1986	
				6. Performing Organization Code	
7. Author(s) Osamu Haga, Noriyuki Hayashi and Kazuo Kasuya				8. Performing Organization Report No.	
				10. Work Unit No.	
				11. Contract or Grant No. NASw- 4004	
9. Performing Organization Name and Address SCITRAN Box 5456 Santa Barbara, CA 93108				12. Type of Report and Period Covered Translation	
12. Sponsoring Agency Name and Address National Aeronautics and Space Administration Washington, D.C. 20546				14. Sponsoring Agency Code	
13. Supplementary Notes Translation of "Glass cloth sekiso kyoka plastic no hakai kijun", Japan Society of Materials Science, Journal, Vol. 25, No. 273, June 1976, pp. 516-520 (A76-41242).					
16. Abstract Failure criteria are derived for several modes of failure (in uniaxial tensile or compressive loading, or biaxial combined tensile-compressive loading) in the case of closely woven plain fabric, coarsely-woven plain fabric, or roving glass cloth reinforcements. The shear strength in the interaction formula is replaced by an equation dealing with tensile or compressive strength in the direction making a 45 degree angle with one of the anisotropic axes, for the uniaxial failure criteria. The interaction formula is useful as the failure criterion in combined tension-compression biaxial failure for the case of closely woven plain fabric laminates, but poor agreement is obtained in the case of coarsely woven fabric laminates.					
17. Key Words (Selected by Author(s)) 1			18. Distribution Statement Unclassified and Unlimited		
19. Security Classif. (of this report) Unclassified		20. Security Classif. (of this page) Unclassified		21. No. of Pages 11	22. Price