

N 86 - 24528

1985

NASA/ASEE SUMMER FACULTY RESEARCH FELLOWSHIP PROGRAM

MARSHALL SPACE FLIGHT CENTER
THE UNIVERSITY OF ALABAMA

AUTOMATION OF ELECTROMAGNETIC COMPATIBILITY
(EMC) TEST FACILITIES

Prepared By: Cecil A. Harrison
Academic Rank: Assistant Professor
University and Department: University of Southern Mississippi
Department of Engineering Technology
NASA/MSFC:
Division: Systems and Components Test
Branch: Experiments and Components Test
MSFC Counterpart: Jimmy W. Rees
Date: August 9, 1985
Contract No: NGT 01-008-021
The University of Alabama in Huntsville

300-3-888

AUTOMATION OF ELECTROMAGNETIC COMPATIBILITY
(EMC) TEST FACILITIES

BY

Cecil A. Harrison
Assistant Professor of Engineering Technology
University of Southern Mississippi
Hattiesburg, Mississippi

ABSTRACT

Efforts to automate electromagnetic compatibility (EMC) test facilities at MSFC are discussed. The present facility is used to accomplish a battery of nine standard tests (with limited variations) designed to certify EMC of Shuttle payload equipment. Prior to this project, some EMC tests were partially automated, but others were performed "manually."

Software has been developed to integrate all testing by means of a desk-top computer-controller. Near real-time data reduction and onboard graphics capabilities permit immediate assessment of test results. Provisions for disk storage of test data permit computer production of the test engineer's certification report. Software flexibility permits variation in the test procedure, the ability to examine more closely those frequency bands which indicate compatibility problems, and the capability to incorporate additional test procedures.

ACKNOWLEDGEMENTS

The author expresses appreciation to Jim Rees of the Experiments and Components Test Branch of the George C. Marshall Space Flight Center whose suggestions, insights and preliminary work were of much value to this project. He also thanks Norm Pabon of the Experiments and Components Test Branch for technical assistance during the project and Glynda Thomas of Systems and Components Test Division for clerical assistance in preparing this report.

I. INTRODUCTION

Two principal considerations determine the electromagnetic compatibility (EMC) of a system or system component:

- (1) emissions from the system or system component which may degrade performance of another system or of another component of the same system,
- (2) susceptibility of the system or system component to emissions from another system or from another component of the same system.

MSFC-SPEC-521A [1], the document which serves to integrate EMC requirements for Shuttle and Spacelab payload equipment, reflects the dual nature of EMC in its broad statement of the EMC requirement:

"Payload equipment shall not generate levels of interference which would degrade performance or cause malfunction in the Orbiter, Spacelab or other payload systems. Payload equipment shall not malfunction due to susceptibility to system emissions."

The EMC requirements set forth in [1] are derived from the "Spacelab Payload Accommodation Handbook" [2], the "Orbiter/Spacelab Interface Control Document" [3], and Space Shuttle System Accommodation Handbook, Vol. XIV [4]. The methods for EMC test and certification which are specified in [1] are consistent with MIL-STD-461B [5] and MIL-STD-462 [6]. An outline of these test specifications may be found in Table 1.

In FY84, MSFC initiated procurement of a computer/controller and the programmable test instruments required to automate EMC test and certification procedures. The goals were:

- (1) to realize the increased accuracy and precision possible with digital instrumentation,
- (2) to achieve a facility in which the entire battery of EMC tests could be performed with a minimum of intervention by the test engineer,
- (3) to realize a significant reduction in the time required to perform the tests, and
- (4) to provide for computer production of the test engineer's certification report.

By mid-1985, the computer/controller, with plotter and printer, and approximately 75% of the instruments had been delivered, and interim programs had been written to run five of the nine standard EMC tests specified by [1].

These interim programs provided only limited flexibility, were not integrated, and did not permit mass storage of test data for later use in certification report production. This paper describes the efforts to increase software flexibility, consolidate the entire test battery under a menu-driven main program, and develop a format for mass (flexible disk) storage of test data consistent with certification report requirements.

II. EMC TEST PROCEDURES

A diagram of the EMC test facility at MSFC may be found in Figure 1. This facility permits what is essentially an open-site measurement technique, with the exception that the screen room serves to eliminate environmental factors and to attenuate background electromagnetic fields. Some questions arise concerning reverberations within the screen room and their effect on measurements; however, the purpose of this project is to automate the existing facility and the test methods specified in [1]. These questions concerning the test facility and test methods will be addressed later.

Conducted Emissions

Conducted emissions are those emissions produced by the unit under test (UUT) and conducted on the power lines. Those conducted emissions which occur on the DC power line during steady state operation induce a voltage across a current probe (loop) (Table 2) placed around the power line. The voltage is measured with a spectrum analyzer, and the spectrum analyzer data is adjusted for probe factors to provide the rms current level in terms of dB relative to 1 uA. For RF emissions (20 kHz to 50 MHz), both narrow band analysis and broad band analysis (dB(uA/MHz)) are performed.

Those conducted emissions which occur during turnon, turnoff or other load changes within the UUT are identified as transient emissions. To measure transient emissions, passive R-L-C networks designed to simulate the Orbiter load impedance are placed in series with the power line, and an oscilloscope is used to monitor the voltage developed between the DC power leads, or between any AC lead and the neutral lead.

Radiated Emissions

Electric field emissions (14 kHz to 10 GHz) radiated by the UUT are detected by antennas (Table 2) located 1 m from the UUT, amplified as required, and measured with a spectrum analyzer. The spectrum analyzer data is adjusted for antenna factors to provide the rms field intensity in terms of dB relative to 1 V/m. Both narrow band analysis and broad band analysis (dB (V/m/MHz)) are performed.

Magnetic field emissions are measured in a similar manner, except that a magnetic pickup coil (Table 2) is used and the rms field intensity is referred to 1 picotesla. Only narrow band analysis is performed.

Conducted Susceptibility

Conducted susceptibility refers to the ability of the UUT to operate without degradation when AC or transient signals are impressed on the power lines. AC signals from a signal generator (Table 3), amplified as required, are applied through an isolation transformer with its secondary in the power lead (30 Hz to 50 kHz), or injected through a capacitor (50 kHz to 400 MHz). A digital voltmeter (rf voltmeter above 100 KHz) is used to monitor the applied voltage. Performance of the UUT is observed as the applied voltage is raised to the required level and swept through the required frequency range.

Susceptibility to conducted transients is determined in a similar manner, except that the applied pulse is monitored with an oscilloscope.

Radiated Susceptibility

Radiated susceptibility refers to the ability of the UUT to operate in the presence of an electromagnetic field. AC signals from a signal generator (Table 3) are amplified as required, and radiated by an antenna (Table 2) located 1 m from the UUT. The radiated electric field intensity is monitored with an E-field meter (14 kHz to 220 MHz) or a power meter (above 220 MHz).

III. AUTOMATION OF TEST PROCEDURES

The principal test instruments listed in Table 3 are all fully programmable and are compatible with GPIB. The GPIB is controlled by a technical computer (HP 9826) with integral VDT and flexible disk drive. High-speed programming language (HPL) is used for the controller program. A thermal dot-matrix printer and an X-Y plotter are also attached to the GPIB (Figure 2).

Program Concept

The several factors considered in arriving at a concept for the controller program were:

- (1) continuity in transition from "manual" to automated procedures,
- (2) functional organization of the procedures with regard to use of test equipment and facilities,
- (3) on-line data reduction,
- (4) flexibility to allow modification of standard test procedures,
- (5) convenient and near-real-time display of test results,
- (6) mass storage of reduced data for later use in producing the EMC certification report.

Data Display

Appropriate VDT cues are provided to keep the test engineer aware of the progress of the test procedure. All test options, such as frequency bands, signal levels, etc., are clearly annunciated so that the test engineer can modify standard test procedures.

All data is available for optional tabulation and/or plotting on the VDT immediately after reduction. At that time the tables or plots may be printed on the thermal printer and the plots may be reproduced on the X-Y plotter. The computer-produced plots are also a major advantage to the test engineer who previously drafted these plots for the certification report.

Data Storage

After execution of a major subprogram, the reduced data may be stored in coordinate pairs on flexible disk. The format of the storage file includes test date, UUT designation, number of data points and an optional comment (up to 350 characters) by the test engineer. A separate file is created on the data disk for each execution of a major subprogram.

IV. PROGRESS SUMMARY

Main Program

The main program is fully operable as described in Section III. No major revisions are planned.

Steady State Emission Tests

Steady state conducted and radiated emission tests are fully operable as described in Section III. Revisions related to the installation of programmable relays and delivery of a rotatable antenna platform are discussed below.

Steady State Susceptibility Tests

Steady state conducted susceptibility tests are operable for frequencies below 1 MHz. The program will be revised to extend the frequency to 400 MHz upon receipt of a programmable RF digital voltmeter. Other revisions related to the installation of programmable relays are discussed below.

The steady state radiated susceptibility test is operable for frequencies above 220 MHz. The program will be revised to extend the frequency to 14 kHz upon receipt of antenna correction factors for the IFI EFG-2 antenna. Other revisions related to the installation of programmable relays are discussed below.

Controller Program Organization

The controller program is organized into nine major subprograms (Figure 3), one to implement each of the nine standard EMC test procedures from [1]. These subprograms are executed under the control of a supervisory program, called the main program, which provides a menu for selection of a standard test procedure. Once the main program was developed, the major subprograms were developed and incorporated. This scheme provided continuity in the transition to automated testing and permitted some automated tests to be performed before all programmable test equipment was delivered and before all major subprograms were developed.

In addition to the menu facility, the main program contains a number of global utility routines such as array and string dimensioning, GPIB device designation, VDT operator cues, plotting, and disk storage. The main program and each of the nine major subprograms are stored in separate files on flexible disk. Loading and execution of the main program causes the menu of standard test procedures to be displayed. When a standard test procedure is selected from the menu, the appropriate major subprogram is loaded from disk and appended to the main program in RAM. The combination of main program and a major subprogram is a complete controller program for execution of a standard test procedure. After execution of the test procedure, the menu is displayed again. Selection of a different test procedure causes a different major subprogram to be loaded in place of the previously selected major subprogram. This scheme minimizes use of RAM for storage of the controller program and leaves adequate RAM for data collection and processing.

There are some functional shortcomings in the controller program organization because most of the standard test procedures cover wide frequency bands which necessitates changing transducers, amplifiers and even the principal instruments during execution of a major subprogram. Execution of the program must be interrupted while the test engineer completes the equipment changes. VDT cues to the test engineer incorporated into the major subprograms are required to facilitate the equipment changes. A better functional organization of the controller program could be realized if each test procedure was associated with a suite of test equipment. This would permit the use of more, but simpler major subprograms which would execute without interruption for equipment change. Plans to incorporate programmable relays and a programmable antenna turntable will eliminate some of these problems. These plans will, however, require even more complex programming in order to make the automated equipment changes transparent to the test engineer.

Data Reduction

The data reduction required in EMC testing includes sampling, averaging, elimination of narrow band noise (filtering) when appropriate, and correction for transducer factors, cable losses and equipment errors. The sampling, averaging and filtering are straight forward and execute quickly. Transducer factors, cable loss data and equipment errors are stored in look-up tables. This real-time data reduction is a major advantage to the test engineer who formerly performed these computations.

Transient Emission and Susceptibility Tests

No work has been done on the tests for transient emissions or susceptibility pending delivery of a programmable storage oscilloscope and a programmable pulse generator.

Programmable Relays

Construction of the programmable relay arrays for selection of transducers and amplifiers is in progress. When these relays are installed, all presently operable tests will be modified to provide programmed relay actuation. At that time, the VDT operator prompts which are presently used to establish the proper interconnection of test equipment will be eliminated. The transient tests will be written to incorporate programmed relay actuation.

Rotatable Antenna Platform

Procurement of a 4-foot diameter table, which is rotatable under program control, is planned. When the table is delivered, some of the antennas used in radiation tests will be placed on the table and the appropriate antenna will be rotated into position by the test program. At that time, the VDT operator prompts which are presently used to establish proper antenna placement will be eliminated.

Production of Certification Report

At this point, only a rudimentary program is available for recovery of the data stored on flexible disk. A more sophisticated program which will recover the data and produce a certification report is planned. This program will use the stored data to produce tables, graphs, etc., and will generate the appropriate text for a certification report ready for the test engineer's signature.

Controller Program Code

The controller program, which consists of more than 3000 lines of code, has not been reproduced here. Inquiries concerning the controller program code may be directed to Mr. Jimmy W. Rees, MSFC, Code ET45, Huntsville, AL 35812.

V. CONCLUSIONS AND RECOMMENDATIONS

The equipment used in the EMC test facility is of highest quality, and careful planning has gone into the interconnection and programming of the equipment. The result should be a first-class EMC test facility capable of being operated with a minimum of intervention by the test engineer. Completion of the plans for computer-generation of the EMC certification report will give this facility a unique capability.

The controller program has been written for use with MSFC-SPEC-521A [1]. Some modification of frequency bands and of signal levels by the test engineer is possible. Consideration should be given to permit other modifications by the test engineer, such as keyboard entry of different limit specifications than those given in [1], or execution of an ad hoc subprogram for a non-standard test.

The requirements of [1] appear to be a compromise between the desired degree of EMC certification for payload equipment and the degree which was possible with "manual" test procedures and analog instruments. The present automated EMC test facility provides better accuracy and precision than was previously available. Accordingly, [1] should be reviewed, and the EMC requirements revised to take advantage of this facility.

As was mentioned in Section II, there are some questions which should be addressed concerning the measurement technique which is possible with this EMC facility.

(1) The test geometry does not conform to standard test geometries recognized by National Bureau of Standards researches for EMI/ECM testing [7].

(2) The ground plane, which has an extent of less than 1 wavelength in some directions at some frequencies, may be inadequate.

(3) The screen room may produce reverberations which are not accounted for in data processing.

(4) The UUT, positioned on a 1-m wide copper bench, 0.5 m from a vertical metal wall, is essentially in a "corner reflector" environment.

MSFC-SPEC-521A
EMC TEST REQUIREMENTS

EMISSION

SUSCEPTIBILITY

CONDUCTED (CE)

- * DC Power Bus Ripple
(30Hz-20kHz)
- * DC Power Bus RF
(20kHz-50MHz)
- * Power Bus Transients

CONDUCTED (CS)

- * DC Power Bus Ripple
(30Hz-50kHz)
- * DC Power Bus RF
(50kHz-400MHz)
- * Power Bus Transients

RADIATED (RE)

- * Electric Field
(14kHz-10GHz)
- * AC Magnetic Field
(20Hz-50kHz)

RADIATED (RS)

- * Electric Field
(14kHz-10GHz)

Table 1. EMC Test Requirements for Space Shuttle Payload Equipment

CONDUCTED EMISSIONS

| | | |
|-----------------|--|-------------------------|
| 30 Hz - 20 kHz | Current Probe | (Electrometrics PCL-10) |
| 20 kHz - 50 MHz | Current Probe | (Empire Devices CP-105) |
| Transients | Orbiter Power Impedance Simulation Network | |

RADIATED EMISSIONS

| | | |
|------------------|-----------------------------|------------------|
| 14 kHz - 30 MHz | E-field Rod Antenna | (EMCO 3301) |
| 30 MHz - 200 MHz | Biconical Antenna | (EMCO 3104) |
| 200 MHz - 1 GHz | Conical Log Spiral Antenna | (Singer 93490-1) |
| 1 GHz - 10 GHz | Conical Log Spiral Antenna | (Singer 93491-1) |
| 20 Hz - 50 kHz | Magnetic Field Pick-up Coil | (EMCO 7604) |

CONDUCTED SUSCEPTIBILITY

| | | |
|------------------|--------------------------------------|--|
| 30 Hz - 50 kHz | Isolation Transformer | |
| 50 kHz - 400 MHz | Capacitor | |
| Transient | Direct Connection to Pulse Generator | |

RADIATED SUSCEPTIBILITY

| | | |
|------------------|----------------------------|-------------------------------|
| 14 kHz - 220 MHz | Antenna | (IFI EFG-2) |
| 220 MHz - 1 GHz | Conical Log Spiral Antenna | (Singer 93490-1) |
| 1 GHz - 10 GHz | Conical Log Spiral Antenna | (Singer 93491-2) |
| 13 GHz - 15 GHz | Standard Gain Horn | (Scientific-Atlanta SGH 12.4) |

Table 2. Transducers

| | | |
|--------------------------|--------------------------------|--------------------|
| CONDUCTED EMISSIONS | | |
| 30 Hz - 50 MHz | Spectrum Analyzer | (HP8566A) |
| Transients | Digital Storage Oscilloscope | (Teletronix 5223)* |
| RADIATED EMISSIONS | | |
| All Tests | Spectrum Analyzer | (HP8566A) |
| CONDUCTED SUSCEPTIBILITY | | |
| 30 Hz - 50 kHz | Synthesizer/Function Generator | (HP3325A) |
| 50 kHz - 400 MHz | Synthesized Signal Generator | (HP8662A) |
| 30 Hz - 100 kHz | Digital Voltmeter | (HP3455A) |
| 200 kHz - 400 MHz | RF Voltmeter | ** |
| Transients | Digital Storage Oscilloscope | (Teletronix 5223)* |
| Transients | Pulse Generator | ** |
| RADIATED SUSCEPTIBILITY | | |
| 14 kHz - 1GHz | Synthesized Signal Generator | (HP8662A) |
| 1 GHz - 2 GHz | Doubler | (HP) |
| 2 GHz - 15 GHz | Synthesized Signal Generator | (HP8672A) |
| 14 kHz - 220 MHz | | |
| 220 MHz - 15 GHz | Power Meter | (HP436A) |

* Delivery Pending

** Delivery pending; exact model not determined

Table 3. Principal Instruments

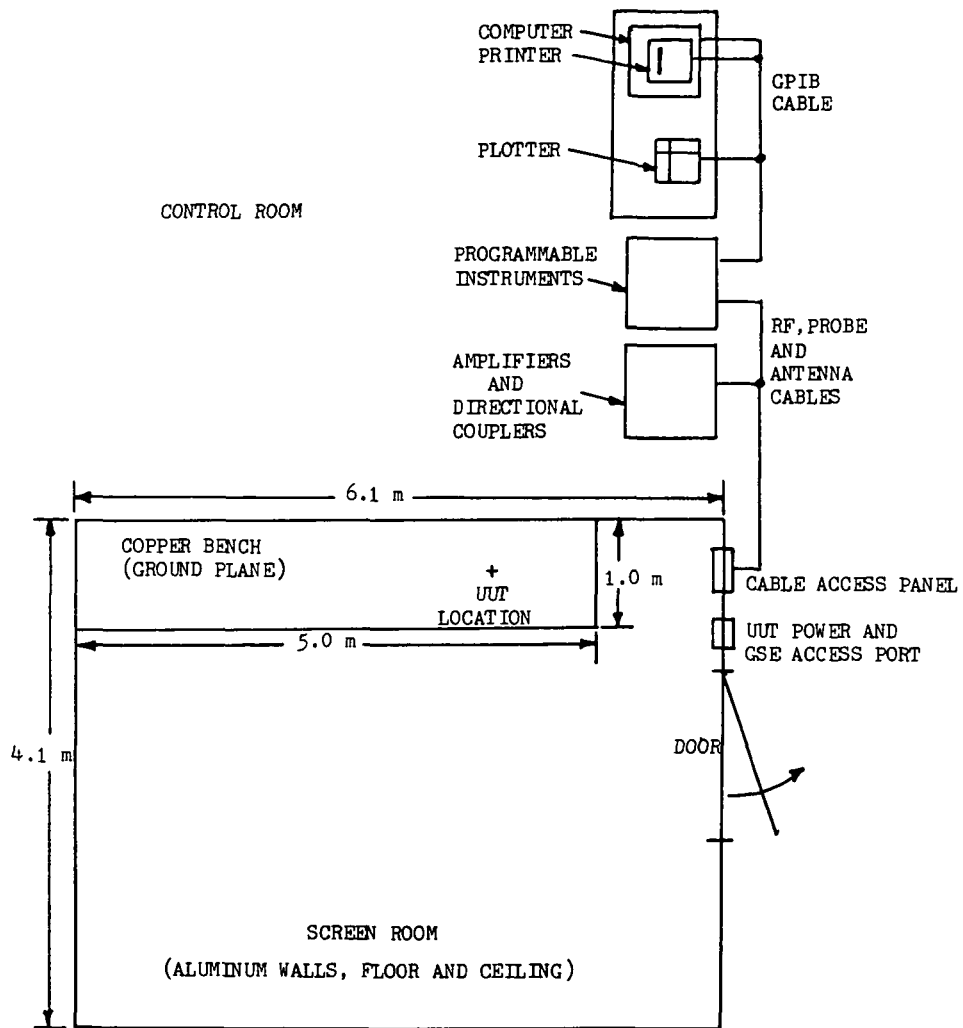

Figure 1. Physical Layout of EMC Test Facility at MSFC

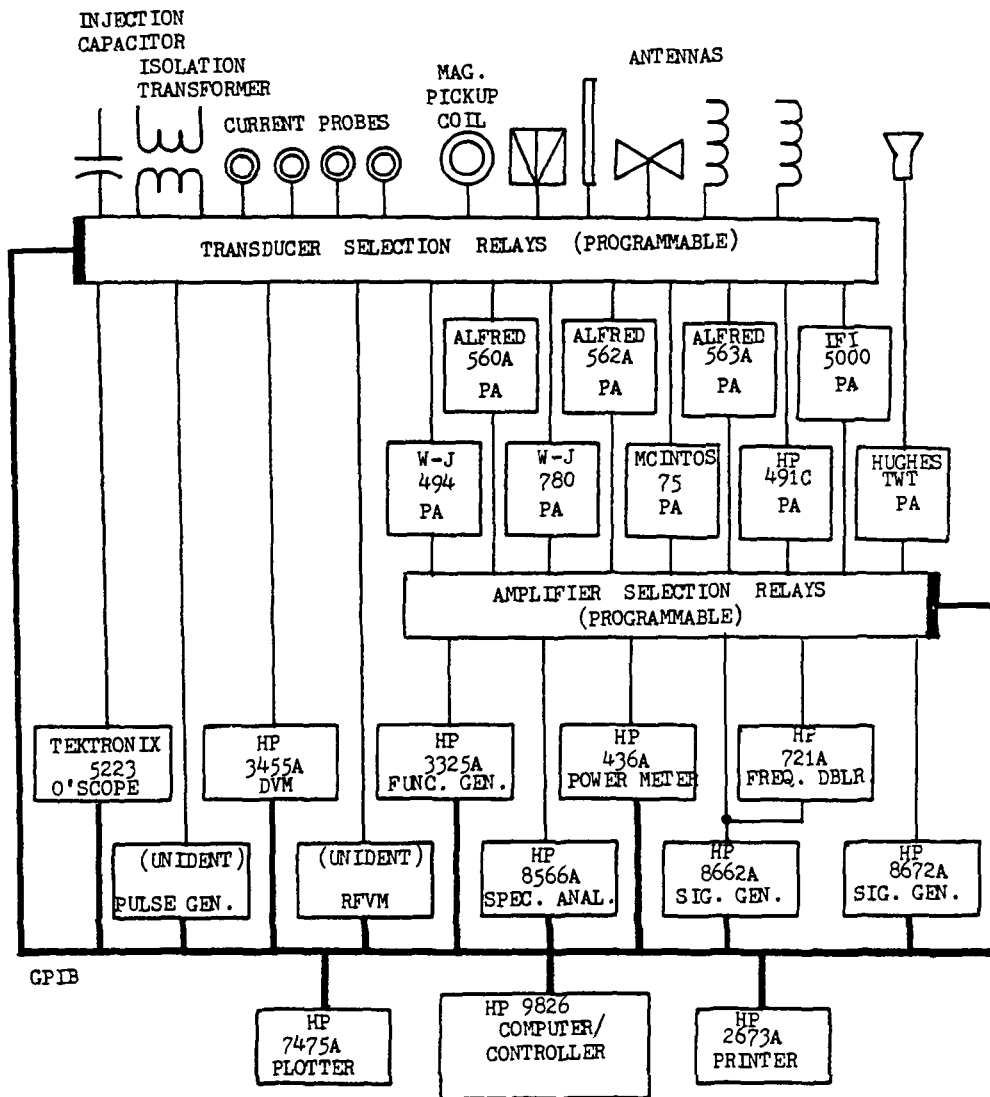

Figure 2. Instrument Suite, EMC Test Facility at MSFC

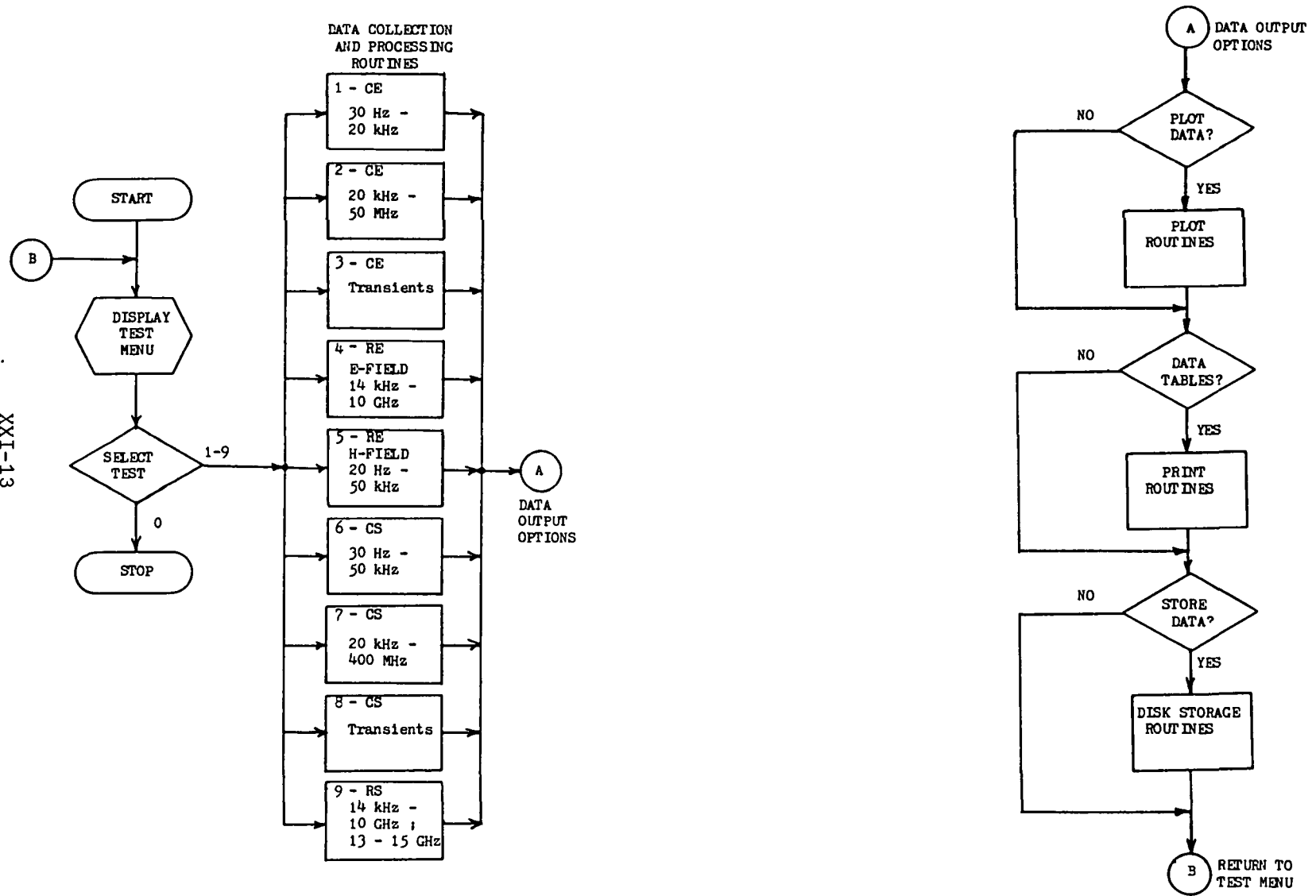

Figure 3. Flow Chart for EMC Test Program

REFERENCES

1. MSFC-SPEC-521A, "Electromagnetic Compatibility Requirements on Spacelab Payload Equipment," February 11, 1983.
2. NASA SLP/2104, "Spacelab Payload Accommodation Handbook," January 31, 1981.
3. Space Shuttle System Payload Accommodation Handbook, Vol. XIV, Revision G, NASA, September 26, 1980
4. NACA, ICD-2-05301, "Orbiter/Spacelab Interface Control Document."
5. MIL-STD-461B, "Electromagnetic Emission and Susceptibility Requirements for the Control of Electromagnetic Interference," April 1980.
6. MIL-STD-462, "Measurement of Electromagnetic Interference Characteristics," July 31, 1967.
7. Ma, M.T., et al, "A Review of Electromagnetic Compatibility/Interference Measurement Methodologies," IEEE Proceedings, vol. 73, no. 3, pp. 388-411, March 1985.