

N 86 - 24529

1985

NASA/ASEE SUMMER FACULTY RESEARCH FELLOWSHIP PROGRAM

MARSHALL SPACE FLIGHT CENTER
THE UNIVERSITY OF ALABAMA

MODELING AND ANALYSIS OF CASCADE SOLAR CELLS

Prepared by: Fat Duen Ho, Ph.D

Academic Rank: Associate Professor

University and Department: The University of Alabama in Huntsville
Department of Electrical and
Computer Engineering

NASA/MSFC:

Laboratory: Information and Electronic Systems
Division: Electrical
Branch: Electrical/Electronic Parts

MSFC Counterpart: Teddy M. Edge

Date: August 9, 1985

Contract No.: NASA-NGT-01-008-021
The University of Alabama in Huntsville

CASCADE SOLAR CELL MODELING

by

Fat Duen Ho
Associate Professor of Electrical and Computer Engineering
The University of Alabama in Huntsville

ABSTRACT

The report begins with a brief review of the present status of the development of cascade solar cells. It is known that photovoltaic efficiencies can be improved through this development. The designs and calculations of the multijunction cells, however, are quite complicated. The main goal of this study is to find a method which is a compromise between accuracy and simplicity for modeling a cascade solar cell. Three approaches are presently under way, among them (1) equivalent circuit approach, (2) numerical approach, and (3) analytical approach. In this report, we only present the discussion concerning the first and the second approaches. The equivalent circuit approach using SPICE (Simulation Program, Integrated Circuit Emphasis) to the cascade cells and the cascade-cell array highlights this report. The methods of extracting parameters for modeling are discussed.

ACKNOWLEDGEMENTS

The author wishes to express appreciation to Mr. Teddy M. Edge, his counterpart at the Marshall Space Flight Center (MSFC), for his help and encouragement. He would also like to express his gratitude to Mr. Michael D. Martin, Chief of the Electrical/Electronic Parts Branch, for his support and generous hospitality during his stay at MSFC. Thanks are extended to Mr. J. L. Miller, Chief of the Electrical Division, for his encouragement.

The author is grateful to Mrs. Martha S. McCartney, an efficient and good-humored secretary of the Branch, who typed this report with skill and patience. His thanks also go to Mr. P. D. McManus and the other members of the Electrical/Electronic Parts Branch for their help and friendship.

I also wish to extend appreciation to Dr. Gerald Karr and other members of the 1985-NASA/ASEE Coordinating Team for selecting me to participate in this program.

1. INTRODUCTION

Although the solar cell is a rather simple semiconductor device, the design of cells for space applications can be difficult. One of the most important reasons is that the cells used in space must be designed for "end-of-life" operation. The radiation damage can affect and degrade minority carrier diffusion length. In order to experimentally study the performance of a cell, it must be irradiated in the laboratory to simulate the radiation damage in the space environment. This is quite a complicated process. The problems are compounded when a cascade solar cell with its multijunctions is under study.

The analytical method developed for cascade solar cells has been discussed elsewhere⁽¹⁾. This analysis obtains a solution for minority carrier concentration for the steady-state integral-differential continuity equation in each distinct zone of the cascade cell. Once the minority carrier solutions satisfy the imposed boundary conditions in each distinct region, the voltage-current relationship for the cascade structure may be obtained, in principle, in closed form. In doing so, we need to solve 14 simultaneous equations to get the V-I relationship even for the simplest cases. Because of this reason, the closed form equation is never explicitly formulated⁽²⁾.

In order to solve this formidable problem, we should pursue vigorously the study of numerical analysis approach and equivalent circuit approach to model a cascade cell. The equivalent circuit approach incorporated with the SPICE (Simulation Program, Integrated Circuit Emphasis) computer program appears to be a method which is a reasonable compromise between simplicity and accuracy and is thus a more likely candidate for extension to the modeling of cascade solar cell arrays for space application.

2. OBJECTIVES

The objective of this work has been (1) to review the present status of the development of cascade solar cells, (2) to identify the problems of modeling cascade solar cells, (3) to develop theoretical models for two-junction cascade structures or three-junction cascade structures for space application, and (4) to specify the experimental work needed for extracting the parameters for modeling.

3. PRINCIPLES OF OPERATION OF CASCADE SOLAR CELL SYSTEMS

3.1 The Concept of Cascade Cells

The maximum theoretical efficiencies for single-crystal solar cells for Air Mass 1, one sun operation are 20%-21% for silicon cells and 21%-23% for gallium arsenide⁽³⁾. Experimental values, however, have remained below 18% at irradiation level of one sun for silicon cells. There are intrinsic limits imposed on the materials due to (a) the finite lifetime of minority carriers and (b) the intrinsic energy bandgap of a given semiconductor material.

There are also losses of potential output. One of them occurs because the photons absorbed in the semiconductor have energy $h\nu$ in excess of the forbidden energy gap E_g ; the excess energy ($h\nu - E_g$) is degraded into heat. The efficiency of solar energy conversion by the photovoltaic effect could be increased significantly by constructing a system of cascade (multijunction, multibandgap) solar cells.

The cascade structure consists of multiple layers of different bandgap materials. The cascade cell concept aims at reducing the losses associated with photons whose energy is not completely utilized, i.e., those associated with the $h\nu - E_g$ losses.

Substantial efficiency increases are expected for tandem cell structures in comparison with single-junction cells⁽⁴⁾. To illustrate the principles underlying the cascade cell concept, we assume that all photovoltaic p/n homojunction cells used in a tandem structure show the same value of the maximum efficiency, η_{\max} . For example, we assume that the tandem system consists of three p/n homojunction cells made from semiconductors with energy gaps $E_{g2} > E_{g1} > E_{g0}$. A rough estimation of the efficiency of tandem cells can be done as follows. Assume that solar illumination of 100 mW is incident on the cell made from E_{g2} in the system. If each of the three cells has an efficiency of 20%, the cell with energy gap E_{g2} will produce 20 mW; the cell with E_{g1} will produce 10 mW due to its short circuit current whose value is one-half what it would have been if the top cell were not present. The cell with E_{g0} will produce a 6.67 mW because its current is one-third of its potential value. The total output of the stack would therefore be 36.7 mW and hence the efficiency of the cascading system of three cells would be 36.7%.

3.2 Fundamental Requirements of Materials for a Cascade Solar Cell

The two fundamental requirements of materials for a monolithic cascade solar cell are (a) a close lattice match between the materials and (b) appropriate bandgaps for the cells.

A number of material combinations in the III-V system meet these criteria⁽⁵⁾. Choices for the narrow-bandgap cell include: the ternaries GaInAs, GaAsSb, InPAs, AlGaSb, and AlInSb. Choices for the wide-bandgap cell include: GaPAs, AlGaAs, GaInP, and AlAsSb.

The $\text{Al}_{1-x}\text{Ga}_x\text{As}$ -GaAs material combination ("x" represents alloy ratio), for all practical purposes, is lattice matched over the complete ternary alloy range. In general, GaAs served as a reasonably well-characterized base material for comparison with other III-V compounds.

In addition to the proper bandgaps and lattice-matched materials, a cascade cell must have other desirable electrical properties. The minority-carrier lifetime must be long enough, which means a diffusion length of several micrometers, for direct band-gap III-V semiconductors. The technology of obtaining a degenerately doped tunneling junction is not trivial. One of the main problems is the doping requirements.

3.3 The Major Components of a Cascade Solar Cell

The major components of a complete cascade solar cell can be summarized as:

- a. Substrate
- b. Low-bandgap cell
- c. Connecting (or tunnel) junction
- d. Wide-bandgap cell
- e. Window layer
- f. Antireflecting layer and ohmic contacts

The connecting (or tunnel) diode is one of the most critical components in the cascade-cell structure^(6,7). It should have a low impedance to current flow in both directions, and a low voltage drop across the diode. It should also present a very low absorption for photons which pass through the top cell. The tunnel junction must have a bandgap as large as that of the top cell.

4. CALCULATIONS AND DESIGN OF A CASCADE SOLAR CELL

4.1 Calculations of the Efficiency of a Cascade Solar Cell

The efficiency of a cascade cell can be more exactly calculated by using the following assumptions:

- (a) The collection efficiency is 100%, i.e., every photon with energy $h\nu > E_g$ contributes one electron charge to the short circuit current, I_{SC} .

(b) If two p/n homojunction cells having E_{g0} and E_{g1} , respectively, form a cascade system, the former is the bottom cell while the latter is the top cell. We also assume that $E_{g1} > E_{g0}$. Then the short circuit current of the form is reduced to

$$I_{SC}(E_{g0}, E_{g1}) = I_{SC}(E_{g0}) - I_{SC}(E_{g1})$$

(c) The reverse saturation current I_0 of the junction can be expressed as

$$I_0(E_G) = K_1 \exp(-E_G/BKT)$$

Where B can be assumed to be equal to 1 and we determine the value of K_1 by choosing the value $I_0 = 2 \times 10^{-12} \text{ A/cm}^2$ for silicon at room temperature.

(d) The voltage at maximum power V_{mp} is given by

$$(1 + \Lambda V_{mp}) \exp(\Lambda V_{mp}) = I_{SC}(E_{g0}, E_{g1})/I_0(E_{g0})$$

(e) The current at maximum power I_{mp} is given by

$$I_{mp}(E_{g0}, E_{g1}) = \frac{\Lambda V_{mp}}{1 + \Lambda V_{mp}} I_{SC}(E_{g0}, E_{g1})$$

(f) The parameter $\Lambda \equiv q/AKT$. It is assumed that $A = 1$.

(g) The maximum efficiency is calculated by

$$\eta_{\max} = \frac{I_{mp} V_{mp}}{P_{in}}$$

Where P_{in} is the input power.

(h) Note that $I_{SC}(E_g)$ can be approximated by

$$I_{SC}(E_g) = I_{SC}(0) \exp(-\alpha E_g)$$

Where $I_{SC}(0)$ is the intercept of the extrapolation of I_{SC} from the semilog region to the ordinate $E_g = 0$ and α is an empirical constant whose value is determined by

$$I_{SC}(E_g) = q \int_{h\nu = E_g}^{\infty} n_{ph}(h\nu) d(h\nu)$$

Where $n_{ph}(h\nu)$ is the number of photons of energy $h\nu$ in the solar spectrum under consideration in the interval $d(h\nu)$.

(i) Also note that for the AMO spectrum, we can approximately have

$$I_{SC}(E_g) = \{ 202 \exp(-1.2 E_g) \} \text{ mA}$$

The values of α range from 1.2 to 2.1 for solar spectra under different atmospheric conditions and solar azimuth.

4.2' Another Method of Calculations

Another approach of calculations of short circuit densities, open-circuit voltages, fill factors, and combined efficiencies has been reported in reference 8.

The short-circuit current densities J_{SC1} and J_{SC2} for cell 1 and cell 2, respectively, are calculated as

$$J_{SC1} = \int_{\lambda_{g1}(\mu\text{m})}^{\lambda_{g1}(\mu\text{m})} qF(\lambda) d\lambda$$

and

$$J_{SC2} = \int_{\lambda_{g1}(\mu m)}^{\lambda_{g2}(\mu m)} qF(\lambda) d\lambda$$

Where $F(\lambda)$ represents the solar photon flux density at λ , which varies with air mass.

The open-circuit voltage V_{OC} for each of the cells can be determined by

$$V_{OC} = \frac{kT}{q} \ln \left(\frac{XJ_{SC}}{J_{oo}} + 1 \right)$$

Where X is the concentration ratio, and

$$J_{oo} = K'T^3 \exp \left(- \frac{E_g}{kT} \right)$$

if a simple diffusion current is assumed. K' may be different for different material.

The fill factor ff for each of the cells is expressed as

$$ff = \frac{V_m}{V_{OC}} \left[1 - \frac{\exp(qV_m/kT) - 1}{\exp(qV_{OC}/kT) - 1} \right]$$

Where V_m is given by

$$\exp \left(\frac{qV_m}{kT} \right) \left(1 + \frac{qV_m}{kT} \right) = \frac{XJ_{SC}}{J_{oo}} + 1$$

The combined efficiency for the two-terminal case is calculated by

$$\eta_{\text{tot}} = J_{\text{SC}} \frac{V_{\text{OC1}} (ff)_1 + V_{\text{OC2}} (ff)_2}{P_{\text{in}}}$$

Where P_{in} is the incident solar power density.

For four-terminal case

$$\eta_{\text{tot}} = \frac{J_{\text{SC1}} V_{\text{OC1}} (ff)_1 + J_{\text{SC2}} V_{\text{OC2}} (ff)_2}{P_{\text{in}}}$$

The discussion concerning the two-terminal structure and the four-terminal structure will be presented in Section 5.

4.3 Tandem Cell Design

The requirements of designing a cascade cell are summarized as follows:

a. Each cell must transmit efficiently the photons with less than its bandgap energy.

b. The contacts on the backs of the upper cells must be transparent to these photons.

c. A good first-order approximation for optimum designs requires the short-circuit currents of the two cells (or three cells) to be equal. This design constraint can be used to obtain a required relationship between the bandgaps of the two cells (or three cells).

5. STUDY OF TWO-JUNCTION CASCADE SOLAR CELL STRUCTURE

The simplest tandem structure consists of two cells, which can be connected to form either two-terminal, three-terminal or four-terminal devices. In a two-terminal or four-terminal device, the cells are connected

in series. In this case, the photocurrent for both junctions of the cascade cells must be equal. On the other hand, in the three- and four-terminal devices, the photocurrents of the two cells do not have to be equal.

Let us now compare the characteristics of two- and four-terminal tandem cells. There is an essential difference between these two structures. A two-terminal device only needs one external circuit load. But the requirements for an equal photocurrent for the whole structure impose a limitation to the choice of energy gaps of the two cells. Furthermore, the calculated maximum photocurrent densities do not only depend on energy gaps, but also depend on air masses. For different air masses, we have different spectral distribution. Therefore, the optimal design for a two-terminal cell in terms of energy gaps for all air masses is much more difficult.

A four-terminal device uses two separate external circuit loads. Because photocurrent matching is not required for this structure, the selection of optimal energy gap combinations for each air mass is much wider. Since the energy gap ranges are greater, the control of energy gaps and film thickness can be much less stringent than that required for two-terminal structures. In four-terminal structures, the variation in overall conversion efficiency is more insensitive to air mass for greater air masses. This differs from that of two-terminal cells, which are more sensitive to it.

A two-terminal tandem structure can be formed by using a transparent conducting bonding material, while the insulating bonding material can be applied to obtain a four-terminal structure.

Further comparison between the two-terminal structure and the four-terminal structure is shown in Table 1.

Table 1. Further Comparison Between the Two-Terminal Structures and the Four-Terminal Structures

	<u>Two-Terminals</u>	<u>Four-Terminals</u>
Bonding	Transparent Conducting Bonding	Insulating Bonding Material
Lattice Matching	Critical	Not Critical
Antireflection Coatings	Simpler (Only the front surface of the top cell requires an antireflection coating.)	More Complicated (AR coatings are needed on the front and back surfaces of the top cell and on the surface of the bottom cell.)
Flexibility	Lower	Higher

Based on the results and progress achieved in multibandgap research, it has been determined that the stacked four-terminal approaches have advantages over two-terminal devices⁽⁸⁾.

6. CASCADE SOLAR CELL MODELING

To date no single model can accurately represent the cascade cells over all ranges of temperature, illumination intensity, and radiation damage. In solar cell modeling, we must meet the following criteria:

a. It must be able to provide sufficiently accurate simulation of I-V curves over the range of interest of temperature, illumination level and radiation damage.

b. It must, with sufficient accuracy, be able to manipulate the I-V curves, as required for predicting the cell performance under certain specified operating conditions.

c. It must be able to extend to the design of the solar array without introducing too much complexity.

Three approaches are presently under way, among them (1) equivalent circuit approach, (2) numerical approach, and (3) analytical approach. In this report, we only present the discussion concerning the first and the second approaches.

6.1 Equivalent Circuit Approach

The equivalent circuit representing a two-junction cascade solar cell is shown in Figure 1. The solar cell diode equations are applied. Terms for the light generated currents, diffusion currents, space charge recombination currents, series and shunt resistance, the resistance for the window layer and the substrate, and the equivalent resistance for the tunnel diode are included. The current sources in the equivalent circuit are as follows:

I_{ph1} = light-generated current for the top cell

$$I_{D1} = I_{01} \left[\exp \left(\frac{qV_{01}}{kT} \right) - 1 \right]$$

$$I_{D2} = I_{02} \left[\exp \left(\frac{qV_{01}}{2kT} \right) - 1 \right]$$

I_{ph2} = light-generated current for the bottom cell

$$I_{D3} = I_{03} \left[\exp \left(\frac{qV_{02}}{kT} \right) - 1 \right]$$

$$I_{D4} = I_{04} \left[\exp \left(\frac{qV_{02}}{2kT} \right) - 1 \right]$$

Where I_{01} = coefficient of diffusion current term for the top cell

I_{02} = coefficient of space charge region recombination current term
for the top cell

I_{03} = coefficient of diffusion current term for the bottom cell

I_{04} = coefficient of space charge region recombination current term
for the bottom cell

V_{01} = the diode voltage inside the top cell

V_{02} = the diode voltage inside the bottom cell

The resistance in the equivalent circuit is defined as follows:

R_{S1} = the series resistance of the top cell

R_{Sh1} = the shunt resistance of the top cell

R_{S2} = the series resistance of the bottom cell

R_{Sh2} = the shunt resistance of the bottom cell

R_w = the resistance of the window layer

R_{sub} = the shunt resistance of the bottom cell

R_{tun} = the equivalent resistance of the tunnel diode

The computer program SPICE (Simulation Program, Integrated Circuit Emphasis) is used to simulate cascade solar cells.

For doing the simulation, we need to determine the values of parameters more accurately. The parameter extraction needs to be done through the experimental work if those values are not available. After we obtain more accurate parameters, we are going to use SPICE to do the following simulations:

- a. The cascade solar cell V-I curve with temperature as a parameter.
- b. Cascade efficiency and top- and bottom-cell efficiencies versus temperature.
- c. Voltage at the maximum power point of the cascade, top and bottom cell V-I curves versus temperature.
- d. The effects of radiation damage.
- e. The effects of the various values of R_{Sh} and R_S .

For studying the radiation effects, we will alter carrier diffusion lengths.

The example we have been using to carry out our modeling study is an AlGaAs/GaAs cascade solar cell. The cross section of this cell has been presented elsewhere⁽⁹⁾, and some useful information can also be obtained in other publications⁽¹⁰⁾.

Note that the equivalent circuit of a cascade solar cell structure is not self-evident. It comes from the solution to the continuity equation. Therefore, the equivalent circuit approach should be studied in conjunction with the numerical or analytical approach or both.

6.2 Numerical Approach

We plan to develop a computer program for modeling cascade solar cells. The equations associated with p/n junctions are given in a normalized form by:

$$J_n = -D_n (n\psi' - n')$$

$$J_p = -D_p (p\psi' + p')$$

$$J_{n'} = U-G$$

$$J_{p'} = (U-G)$$

$$\psi'' = n-p-N$$

The above equations are normalized by the following:

$$\text{Position: } L_D = (\epsilon_s kT/q^2 n_i)^{1/2}$$

Potential:

Carrier/Impurity Concentration: n_i

Mobility: $M_0 = 1 \text{ cm}^2/\text{V-sec}$

Diffusion Constant: $D_0 = 1 \text{ cm}^2/\text{sec}$

Current Density: $q n_i D_0/L_D$

Time: L_D^2/D_0

Our program is planned to solve the three-coupled, nonlinear partial differential equations, Poisson's equation, and the hole and electron continuity equations in both one-dimension and two-dimensions in a cascade cell subject to appropriate boundary conditions. Finite difference methods will be used to discretize the equations. The basic solutions of the equations will consist of the electric field - or equivalently, the electrical potential -and the hole and electron concentrations.

7. PHOTOVOLTAIC MEASUREMENTS

The performance of solar cells is critically related with the properties of the semiconductors, as well as the nature of the photovoltaic barrier interface. Therefore, it is important to measure the basic material and interface parameters. Some of the important photovoltaic measurements⁽¹¹⁾ are very briefly discussed as follows.

7.1 Current-Voltage Characteristics

The essential performance parameters of a solar cell, i.e., the open-circuit voltage V_{OC} , the short-circuit current I_{SC} , the fill factor ff , and the cell efficiency can be determined by using the I-V characteristics under illumination. Besides these external performance parameters of the solar cell, the internal parameters such as series resistance R_S , shunt resistance R_{Sh} , and reverse saturation current I_0 are also important. I_0 and n (the ideality or quality factor) can be evaluated by the dark I-V characteristics, while R_S and R_{Sh} may be obtained from the illuminated I-V curves.

The dark I-V characteristics can be very useful in identifying the recombination mechanisms such as bulk diffusion - recombination, space charge region generation-recombination, thermionic emission, thermionic-assisted tunneling, and direct or trap-assisted tunneling.

7.2 Spectral Response and Quantum Efficiency

The spectral response indicates the relative contribution of photons of different energy to the short-circuit photocurrent of the solar cell. The external quantum efficiency η_{ext} is defined as

$$\eta_{\text{ext}}(\lambda) = \frac{I_{\text{SC}}(\lambda)}{q\phi(\lambda)}$$

Where $\phi(\lambda)$ represents the photon flux per second at λ incident on the cell. A plot of η_{ext} versus λ gives the absolute spectral response, which is determined by the optical absorption coefficient $\alpha(\lambda)$, the minority carrier diffusion length ℓ , the surface recombination velocity S , the type of, photovoltaic barrier, and the presence of antireflection coatings. So, the measurement on spectral response can be helpful to evaluate the cell's performance.

7.3 Diffusion Length

The minority carrier diffusion length is one of the most important material parameter of a solar cell. It determines the photocurrent, the limiting value of the dark current and, therefore, the open-circuit voltage. The three most common methods for measuring this parameter are:

- a. Spectral response measurements
- b. Surface photo voltage measurements
- c. Beam-induced current measurements.

The more detailed discussion can be found in Reference 11.

7.4 Minority Carrier Lifetime

There are many methods for measuring the minority carrier lifetime in the base of p/n junction, both in dark and in illuminated conditions⁽¹¹⁾. Some of the lifetime measurement techniques are: (a) the open-circuit voltage decay, (b) diode reverse recovery, (c) small signal impedance measurement, (d) light induced photovoltaic decay, (e) open circuit to short circuit switching, and (f) the decay of light induced short circuit current.

There are many articles concerning mathematical formulations for these methods. The transient behavior of the p/n junction devices during experiments of minority lifetime measurements has been explained successfully with the help of some models^(12,13). The author of this report has been studying an equivalent circuit approach incorporating the SPICE computer program to study this transient behavior. It is expected that some positive results will be obtained from this investigation.

8. CONCLUSION AND RECOMMENDATIONS

The cascade solar cell is one of the most promising devices for increasing the conversion efficiency. The main problems of the two-terminal cascade structures are the growth of high-quality semiconductor layers under lattice-mismatching conditions and the development of low-impedance connection between the top cell and the bottom cell. Because photocurrent matching is not necessary for the cells, four-terminal devices have some important advantages over two-terminal devices. Progress has been made in improving and in studying four-terminal structure, but a lot of room for improvement remains. More study should be done on these four-terminal devices.

This study also suggests the importance of modeling the cascade solar cells. It is concluded that we should pursue vigorously the study of numerical analysis approach and equivalent circuit approach to model a cascade cell.

The latter approach incorporated with the SPICE computer program appears to be a method which is a compromise between simplicity and accuracy and is thus a more likely candidate for extension to the modeling of cascade solar cell arrays for space applications. Therefore, it deserves much more attention.

We also recommend that much more vigorous efforts should be done in the experimental work concerning extraction of the parameters of the cells.

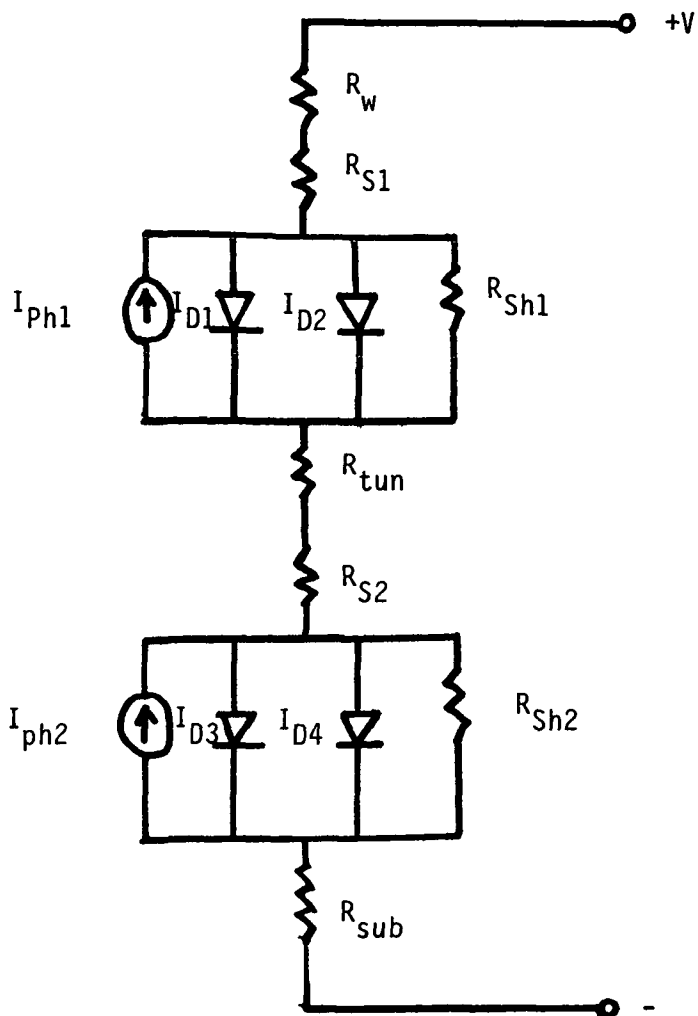

Figure 1. Equivalent Circuit Model of a Cascade Solar Cell for SPICE Simulation

REFERENCES

1. M. F. Lamorte and D. H. Abbott, IEEE Trans. Electron Devices, Vol. ED-27, 231-249, 1980.
2. M. F. Lamorte and D. H. Abbott, Solar Cells, Vol. 9, 311-326, 1983.
3. S. M. Bedair, Solar Cells, Vol. 12, 11-16, 1984.
4. J. J. Loferski, Twelfth IEEE Photovoltaic Specialists Conf. Proc., Baton Rouge, LA, 957-961, 1976.
5. S. M. Bedair, S. B. Phatak, and J. R. Hauser, IEEE Trans. Electron Devices, Vol. ED-27, 822-831, 1980.
6. S. M. Bedair, J. Appl. Phys. (50(11), 7267-7268, 1979.
7. J. P. Contour and A. M'Baye, Solar Cells, Vol. 13, 67-76, 1984.
8. J.C.C. Fan and B. J. Palm, Solar Cells, Vol. 12, 401-420, 1984.
9. M. F. Lamorte and D. H. Abbott, Solar Cells, Vol. 9, 311-326, 1983.
10. R. C. Knechtli, R. Y. Loo, and G. S. Kamath, Electron Devices, Vol. ED-31, 577-588, 1984.
11. S. Ashok and K. P. Pande, Solar Cells, Vol. 14, 61-81, 1985.
12. S. R. Dhariwal and R. Gadre, Solid State Electronics, Vol. 27, 837-847, 1984.
13. S. R. Dhariwal and N. K. Vasu, Solid State Electronics, Vol. 24, 915-927, 1981.