

N86 - 24537

1985

NASA/ASEE SUMMER FACULTY RESEARCH FELLOWSHIP PROGRAM

MARSHALL SPACE FLIGHT CENTER

THE UNIVERSITY OF ALABAMA AT HUNTSVILLE

A STUDY OF 35-GHZ RADAR-ASSISTED
ORBITAL MANEUVERING VEHICLE/SPACE TELESCOPE DOCKING

Prepared by: Malcolm W. McDonald, Ph.D.

Academic Rank: Associate Professor

University/Department: Berry College
Department of Physics

NASA/MSFC:
(Laboratory) Information & Electronic Systems
(Division) Computers and Communication
(Branch) Communication Systems

MSFC Counterpart: E. H. Gleason

Date: August 16, 1985

Contract Number: NGT-01-008-021
The University of Alabama
at Huntsville

XXX

A STUDY OF 35-GHZ RADAR-ASSISTED
ORBITAL MANEUVERING SYSTEM/SPACE TELESCOPE DOCKING

By

Malcolm W. McDonald
Associate Professor of Physics
Berry College
Mount Berry, Georgia

ABSTRACT

An experiment was conducted to study the effects of measuring range and range rate information from a complex radar target (a one-third scale model of the Edwin P. Hubble Space Telescope). The radar ranging system was a 35-GHz frequency-modulated continuous wave unit developed in the Communication Systems Branch of the Information and Electronic Systems Laboratory at Marshall Space Flight Center. Measurements were made over radar-to-target distances of 5 meters to 15 meters to simulate the close distance realized in the final stages of space vehicle docking.

The Space Telescope model target was driven by an antenna positioner through a range of azimuth and elevation (pitch) angles to present a variety of visual aspects of the aft end to the radar. Measurements were obtained with and without a cube corner reflector mounted in the center of the aft end of the model. The results indicate that range and range rate measurements are performed significantly more accurately with the cooperative radar reflector affixed. The results further reveal that range rate (velocity) can be measured accurately enough to support the required "soft" docking with the Space Telescope.

ACKNOWLEDGEMENTS

I am grateful to Marshall Space Flight Center, NASA, ASEE, and The University of Alabama at Huntsville for the opportunities provided by the Summer Faculty Research Fellowship Program. The privilege of working with NASA personnel on problems of mutual interest is stimulating, challenging, and gratifying. The summer program was made valuable by the capable leadership and coordination of Dr. Gerald Karr, Dr. James Dozier, and Mr Leroy Osborne.

Special thanks is given to my NASA counterpart, Mr. Ed Gleason, and my associate NASA counterpart, Mr. Lee Malone, for their full encouragement and support at all times. I salute them both for their refreshing latitude of ideas from which I was able to focus on this chosen topic of study.

My indebtedness to the personnel of the Communications Branch who have exercised roles directly supporting my work on this project is so great as to make me humble. Those individuals include, in addition to those already mentioned, Mr. Grover Tucker, Mr. Steve Jones, Mr. Ed Martin, Mr. Dave Harris, Mr. Reggie Inman, and Mr. Allen Duncan. I thank you all.

Indispensable assistance was rendered by a very capable and clever computer programmer, Mr. Randy Kirby. His skills enabled automation of the collection, analysis, and graphical plotting of the experimental data. This resulted in an incalculable savings of time and effort for me. I extend my sincere thanks.

LIST OF FIGURES AND TABLE

<u>Figure</u>	<u>Title</u>	<u>Page</u>
1.	The Edwin P. Hubble Space Telescope	5
2.	A Concept of the Orbital Maneuvering Vehicle	6
3.	Range vs. Target Aspect (Nominal Range of 5m; WITHOUT Cube Corner Reflector)	11
4.	Range vs. Target Aspect (Nominal Range of 5m; WITH Cube Corner Reflector)	12
5.	Five-Meter Ranging W/WO Cube Corner Reflector (Target Pitch Angle = 0 Degrees)	13
6.	Five-Meter Ranging W/WO Cube Corner Reflector (Target Pitch Angle = 10 Degrees)	14
7.	Five-Meter Ranging W/WO Cube Corner Reflector (Target Pitch Angle = 20 Degrees)	15
8.	Range vs. Target Aspect (Nominal Range of 10m; WITHOUT Cube Corner Reflector)	16
9.	Range vs. Target Aspect (Nominal Range of 10m; WITH Cube Corner Reflector)	17
10.	Ten-Meter Ranging W/WO Cube Corner Reflector (Target Pitch Angle = 0 Degrees)	18
11.	Ten-Meter Ranging W/WO Cube Corner Reflector (Target Pitch Angle = 10 Degrees)	19
12.	Ten-Meter Ranging W/WO Cube Corner Reflector (Target Pitch Angle = 20 Degrees)	20
13.	Range vs. Target Aspect (Nominal Range of 15m; WITHOUT Cube Corner Reflector)	21
14.	Range vs. Target Aspect (Nominal Range of 15m; WITH Cube Corner Reflector)	22
15.	Fifteen-Meter Ranging W/WO Cube Corner Reflector (Target Pitch Angle = 0 Degrees)	23
16.	Fifteen-Meter Ranging W/WO Cube Corner Reflector (Target Pitch Angle = 10 Degrees)	24
17.	Fifteen-Meter Ranging W/WO Cube Corner Reflector (Target Pitch Angle = 20 Degrees)	25
18.	Velocity vs. Time W/WO Cube Corner Reflector (Target Aspect Fluctuating Randomly)	28
19.	Velocity vs. Time W/WO Cube Corner Reflector (Target Aspect Stable)	29

Table

I.	Parameters Pertinent to OMV-ST Docking	7
----	--	---

I. INTRODUCTION

The Edwin P. Hubble Space Telescope (ST), illustrated in Fig. 1, is due to be launched into orbit from the shuttle in approximately one year. After approximately ten years in service it is scheduled to be retrieved and returned to the shuttle, the space station, or earth for refurbishing. Then it will be reboosted into orbit for another period of use.

The vehicle planned for use in rendezvous, docking, and retrieval of the ST is the Orbital Maneuvering Vehicle (OMV). A concept drawing of the OMV is shown in Fig. 2. The OMV will be carried aloft and released by the shuttle to participate in the rendezvous and docking procedure.

Studies have led to the establishment of maximum dynamic parameters for the OMV/ST docking encounter, to prevent excessive agitation of the ST (Ref. 3). Pertinent docking limitations are listed in Table I. The work reported in this paper was designed to test the ability of a 35 GHz radar system, assumed mounted on the OMV, to measure range and range rate (velocity) information with an accuracy sufficient to support a "soft" docking between the OMV and the ST. The study focuses on the evaluation of a need for a cooperative radar target aid (cube corner or other high radar cross section reflector) to serve as a well-defined range reference on the ST aft end.

Docking simulation studies recently reported at Marshall Space Flight Center revealed that the most capable human pilot in the study performed the most accurate docking of the OMV with the ST when armed with range rate information in addition to the visual information provided by a video camera (Ref. 4). This seems especially necessary because of the low limiting closing velocity of slightly over 3 cm/sec at the point of contact.

II. RADAR SYSTEM

The radar system used in this work has been adequately described in previous papers (Refs. 1 and 2). It operates in a frequency-modulated continuous wave mode at a center frequency of 35 gigahertz with a transmitted power level of 5 milliwatts. The radar uses a single transmit/receive parabolic dish antenna with a 15 cm diameter and a 3dB-to-3dB beamwidth of 4 degrees. As a result, the ST model target subtended an angle larger than the beamwidth at all the ranges studied (5 to 15 meters).

Previous experimentation in the laboratory with cube corner targets had revealed the radar range measuring accuracy on the

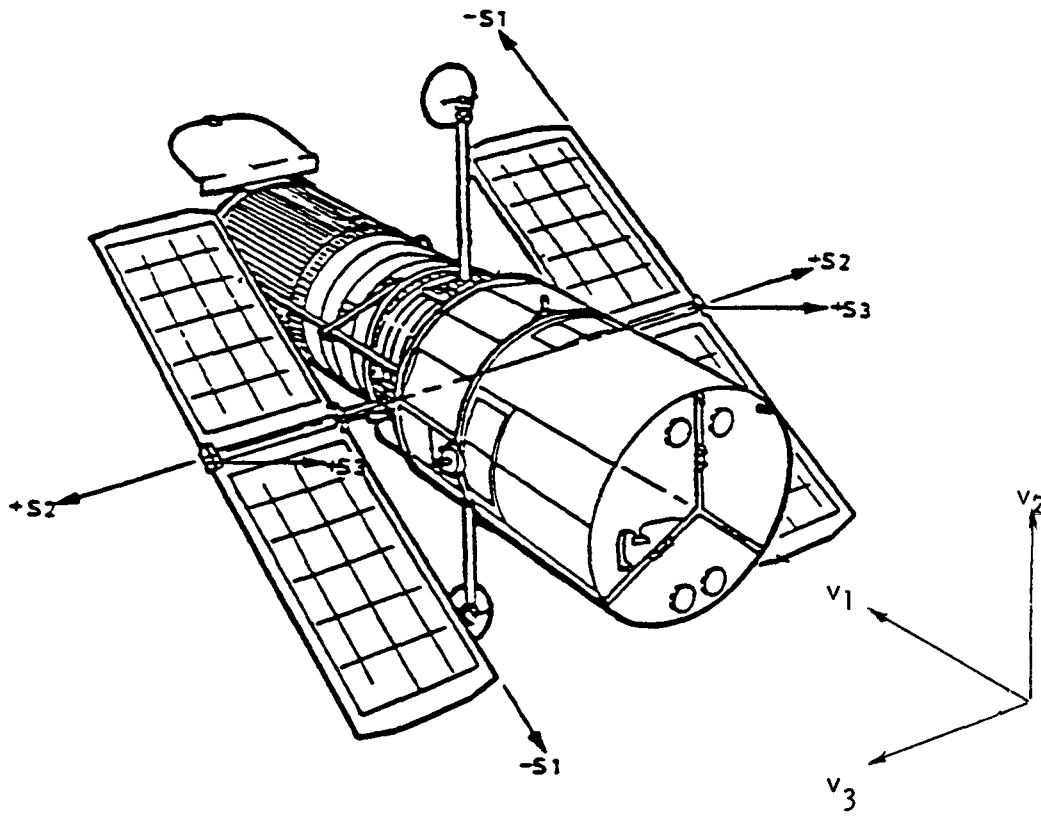

Figure 1. The Edwin P. Hubble Space Telescope. The vehicle coordinate system (v_1, v_2, v_3) is referred to in the text. The v_2 axis is called the "azimuth" axis and the v_3 axis is called the "pitch" axis.

ORIGINAL PAGE IS
OF POOR QUALITY

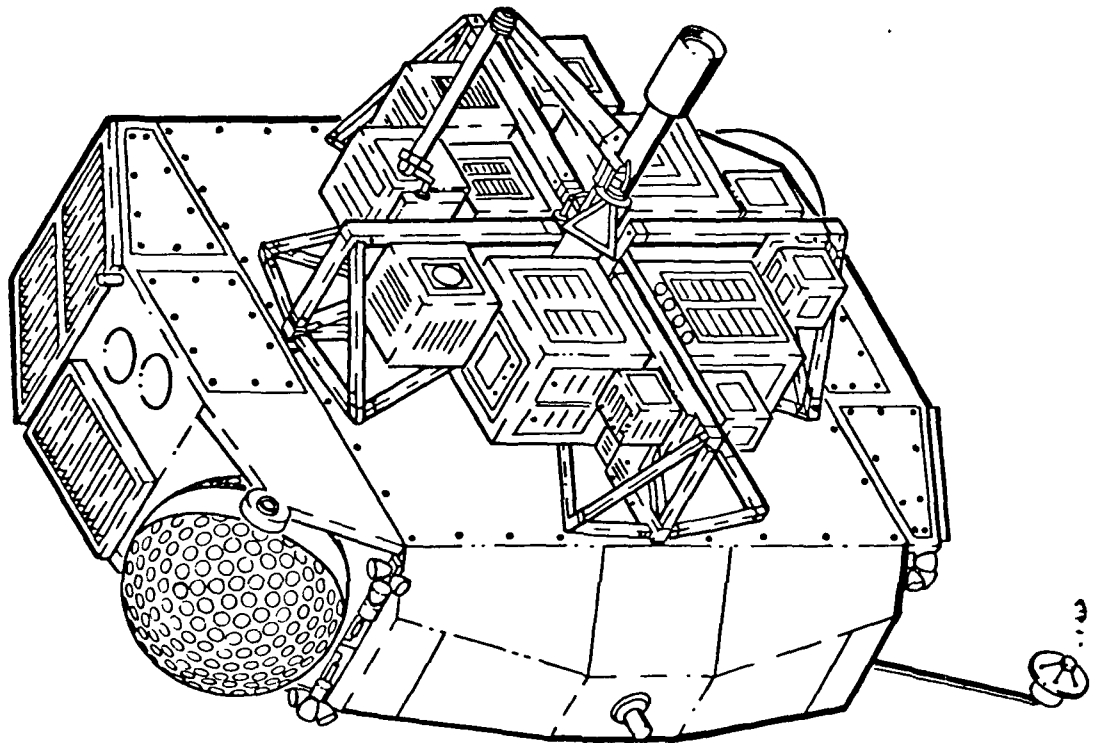

Figure 2. A Concept of the Orbital Maneuvering Vehicle (OMV).

OMV-ST MASSES AND LOAD LIMITS

ST MASS	10800 Kg
OMV MASS (NOMINAL).....	4000 Kg
MAX. IMPACT FORCE ON ST	2320 N
MAX. ST ACCELERATION ..	0.023g
MAX. SOLAR ARRAY ACCEL.	
(a) Sustained	0.002g
(b) Impulse	0.005g
<u>MAX. OMV-ST IMPACT VEL.</u>	<u>3.05 cm/s</u>

TABLE I. Parameters Pertinent to OMV-ST Docking. Note that the key limiting parameter is the maximum OMV-ST closing velocity of slightly more than three centimeters per second.

order of 0.1% to 0.2% of range for ranges up to 5 meters. The current work looked at the ability of the radar system to range off a complex target, the aft end of a one-third scale model of the ST. That will be the docking location for the OMV.

III. SPACE TELESCOPE MODEL TARGET

A one-third scale model of the ST, available at the antenna range at Marshall Space Flight Center, was used in this experiment. The model measured 4.3 meters in length and the aft end measured 1.4 meters in diameter.

The model was mounted on an antenna positioner at one end of the 400-foot antenna range. The model could be rotated by the positioner about a horizontal axis (S2 or V3 in Fig. 1) extending through the two solar array support arms. That angular rotation is referred to as the "pitch" angle. The positioner was able to rotate the model about a vertical axis. That rotational displacement is referred to as "azimuth".

The term "aspect" is taken to mean the prevailing combination of azimuth and pitch as the radar views the aft end of the ST model. For reference, the normal aspect was defined as 0 degrees in both azimuth and pitch when the radar viewed along the V1 axis of the model (See Fig. 1).

The aspects of the model viewed by the radar were limited to azimuth variations from -20 degrees to +20 degrees coupled with pitch angles from 0 to +20 degrees. Those pitch angles represent the aft end elevated above the horizontal. Negative pitch angles were not studied as they were assumed to image approximately what was observed at the positive angles. Also, pitching the model up tended to reflect radar energy up into the sky rather than toward the ground. The negative pitches would have allowed some multipath radar returns, not typical of the free space environment in which the docking will take place, which were eliminated by the use of the positive pitch angles.

IV. EXPERIMENTAL PROCEDURE

The radar system was mounted in a movable gantry at approximately the same height as the pitch axis of the model. The gantry was mounted on flat rails and was driveable either toward or away from the target at a constant speed in either direction. The average speed of the gantry, and thus the radar, was measured accurately over a ten-meter distance to be 13.3 cm/sec as it moved toward the target. In fact, the radar moved along at the top of the gantry elevated some 6 meters above the rails with a jerking

or oscillatory motion, producing instantaneous speeds above and below the measured average speed.

The radar unit was mounted in the gantry on a pan and tilt turret which allowed the antenna boresight to be guided during the course of the experiment. A video camera mounted alongside the radar and pointed in the same direction provided a view of the target on a monitor. The radar was steered manually to keep the boresight pointed toward a reference point at the center of the aft end of the ST model.

The experiment consisted of range measurements with the gantry at rest at nominal target distances of 5, 10, and 15 meters while the target was swept from -20 degrees to +20 degrees with a fixed pitch of 0, 5, 10, 15, or 20 degrees. The "nominal" distances were the actual distances from a reference point at the center of the target aft end to the center of the radar dish for normal aspect. The actual range varied somewhat throughout an azimuthal sweep.

All the range measurement runs were performed first without, then with, a cube corner reflector affixed at the center reference point of the ST model aft end. The cube corner measured 15.2 cm along each of its mutually perpendicular edges and presented a maximum radar cross section of 14.7 dB above one square meter.

Velocity measurements were performed by moving the gantry along its track toward the target both with and without the cube reflector in place. Additionally those runs were performed both with, in one instance, the aspect of the model randomly varying as the azimuth and pitch were manually driven by a human operator in a range of values + or - 5 degrees on either side of the normal aspect during the run, and secondly, without the model executing any change in position, rather maintaining a constant attitude. In the latter runs the target was in the normal aspect position.

The experimental runs were performed under the control of a cleverly written program executed on a Hewlett-Packard model 9836 computer. The program controlled the azimuthal sweep of the model during the range measurement runs. It acquired radar data at a rapid sampling rate and at one-degree azimuth increments calculated and stored values of range, range rate, theoretical range, theoretical range rate, and real time. The so-called "theoretical" range and range rates were computed from equations based upon the prevailing geometry of the target-radar system and the trigonometric relations of the aspect angles and their rates of change.

During the velocity measurement runs the computer sampled the range and real time clock at a rapid rate. It computed the

velocity from the changes in those data and stored the results in a sliding array. The average value in the sliding array was computed and stored as the velocity value representative of each one second time increment to provide a second-by-second history of the velocity of the radar relative to the ST model. The range data was handled in a sliding array in a similar manner.

V. DATA ANALYSIS AND RESULTS

The results of the nominal 5-meter range measurements are illustrated in Figs. 3-7. Figure 3 demonstrates large fluctuations in measured range at pitch angles up to 10 degrees when the radar was viewing the ST model without the cooperative target aid affixed. The wild fluctuations were determined to be due to enhanced multiple reflections (radar antenna to target, back to gantry structure, back to target, and back into the radar antenna) at certain viewing aspects, effectively doubling the perceived range in those instances.

Although the multiple reflection spurious behavior resulted from an unintended interaction of the radar signal with the gantry structure, it was immediately realized that a similar interaction could be expected to occur at close range between the ST and the OMV. Thus it simulated a very real condition to be anticipated.

In Figs. 3 and 4 the range scale was chosen to illustrate the gross results at all five pitch angles studied. As indicated, the range scale is noncontinuous, and each unit on the scale is representative of 2.5 meters. In all the range graphs presented in Figs. 3-17 the dotted curves are "theoretical" range as explained earlier. The dotted curves serve as handy references in spite of their minor inaccuracies stemming from differences between the actual geometry of the experiment and the assumed geometry in the equation for calculating the "theoretical" range.

Figure 4 illustrates the improved ranging capability when the cube corner reflector is affixed to the target. Figures 5-7 highlight comparisons with and without the target aid at pitch angles of 0, 10, and 20 degrees, respectively. Note the range scale is expanded by a factor of ten to emphasize the comparison.

Figures 8-12 display similar kinds of data for a nominal range of 10 meters. At this increased distance the spurious range measurements were observed over a smaller set of pitch and azimuth angles, as might be expected. Again the measurements are improved by the presence of the cube corner reflector.

The fifteen-meter nominal ranging results are shown in Figs. 13-17. Note in the interpretation of the last three graphs

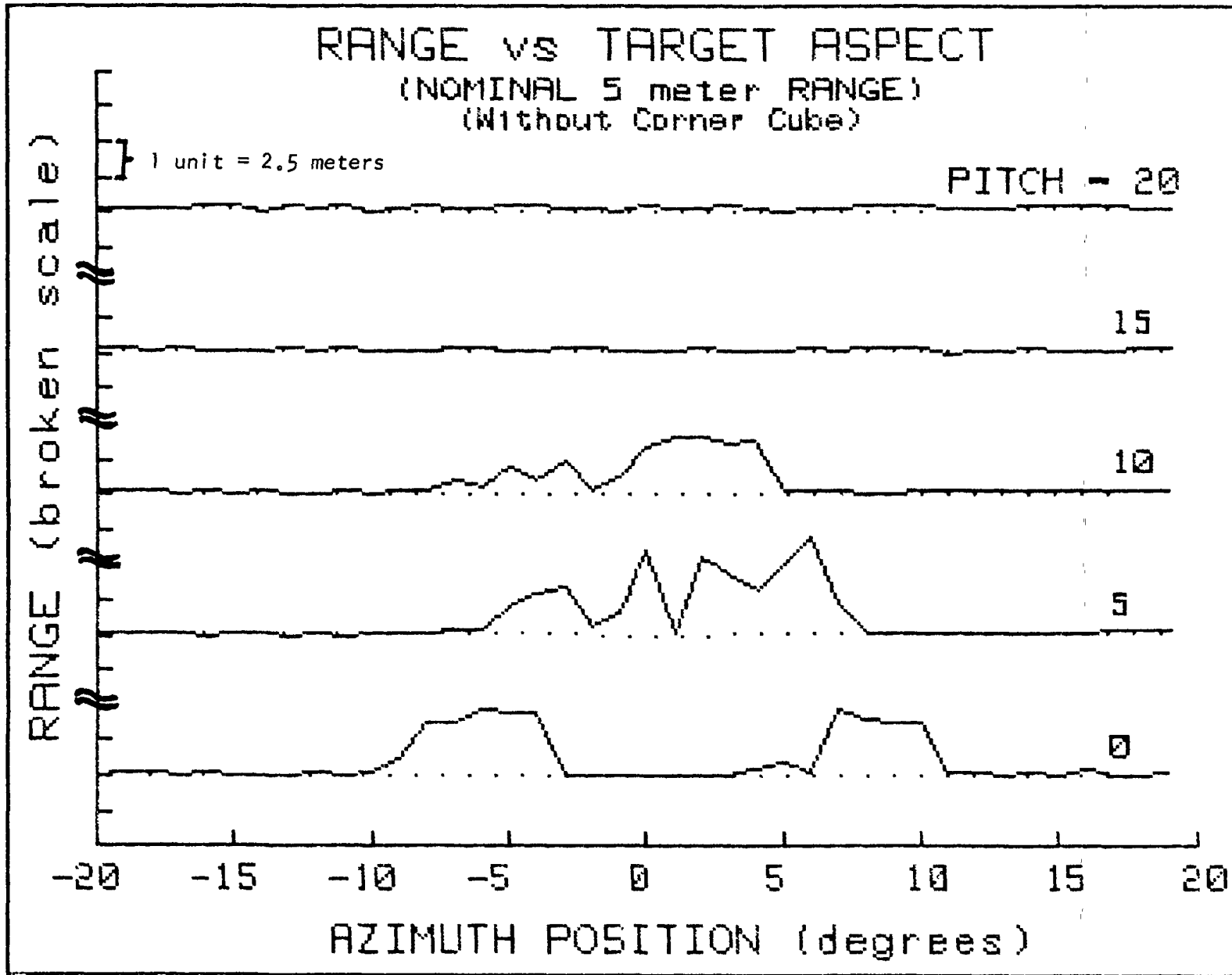

Figure 3. Range vs. Target Aspect (Nominal Range of 5 meters; WITHOUT a Cube Corner Reflector)

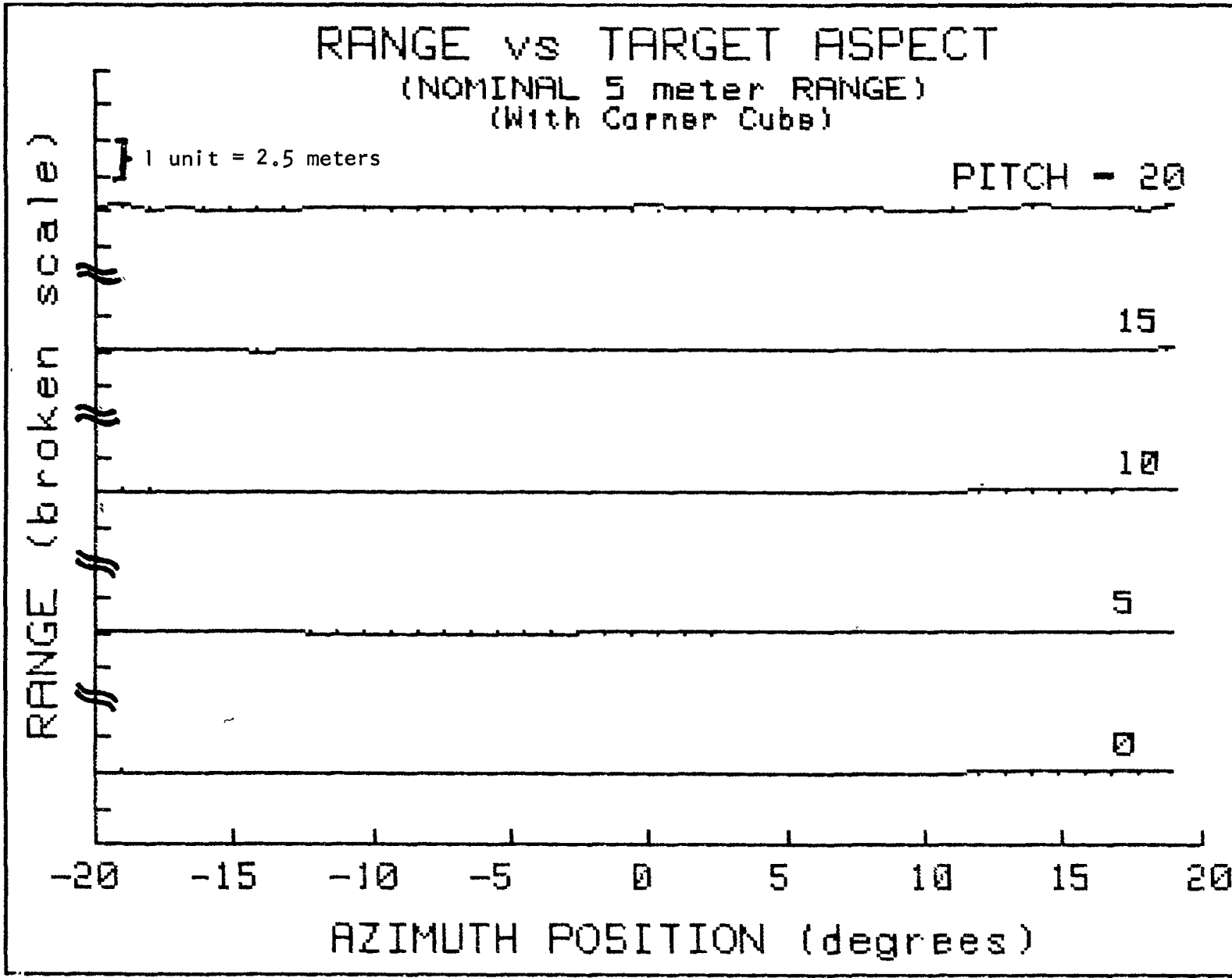

Figure 4. Range vs. Target Aspect (Nominal Range of 5 meters; WITH Cube Corner Reflector)

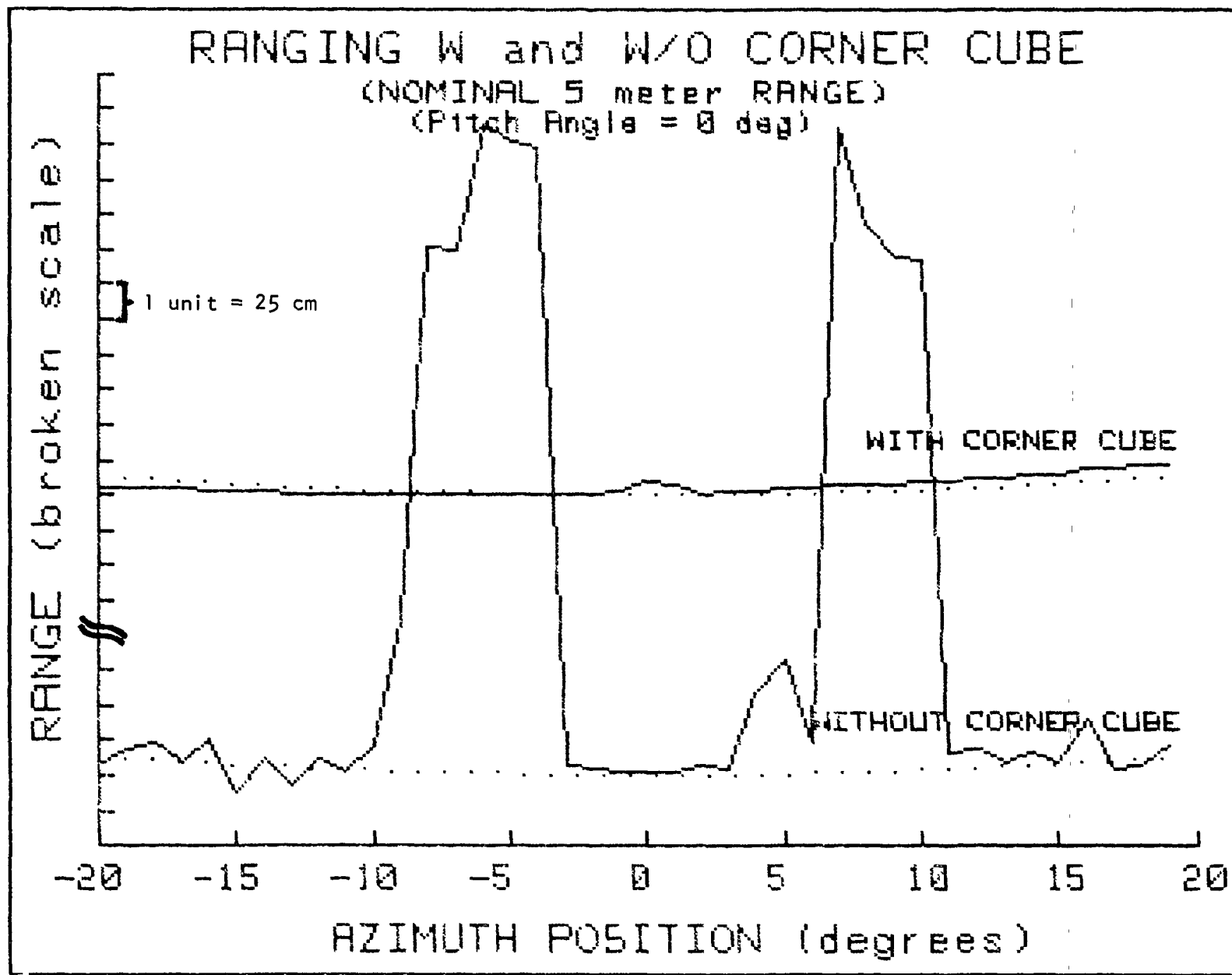

Figure 5. Five-Meter Ranging With and Without Cube Corner Reflector. (Target Pitch Angle = 0 Degrees)

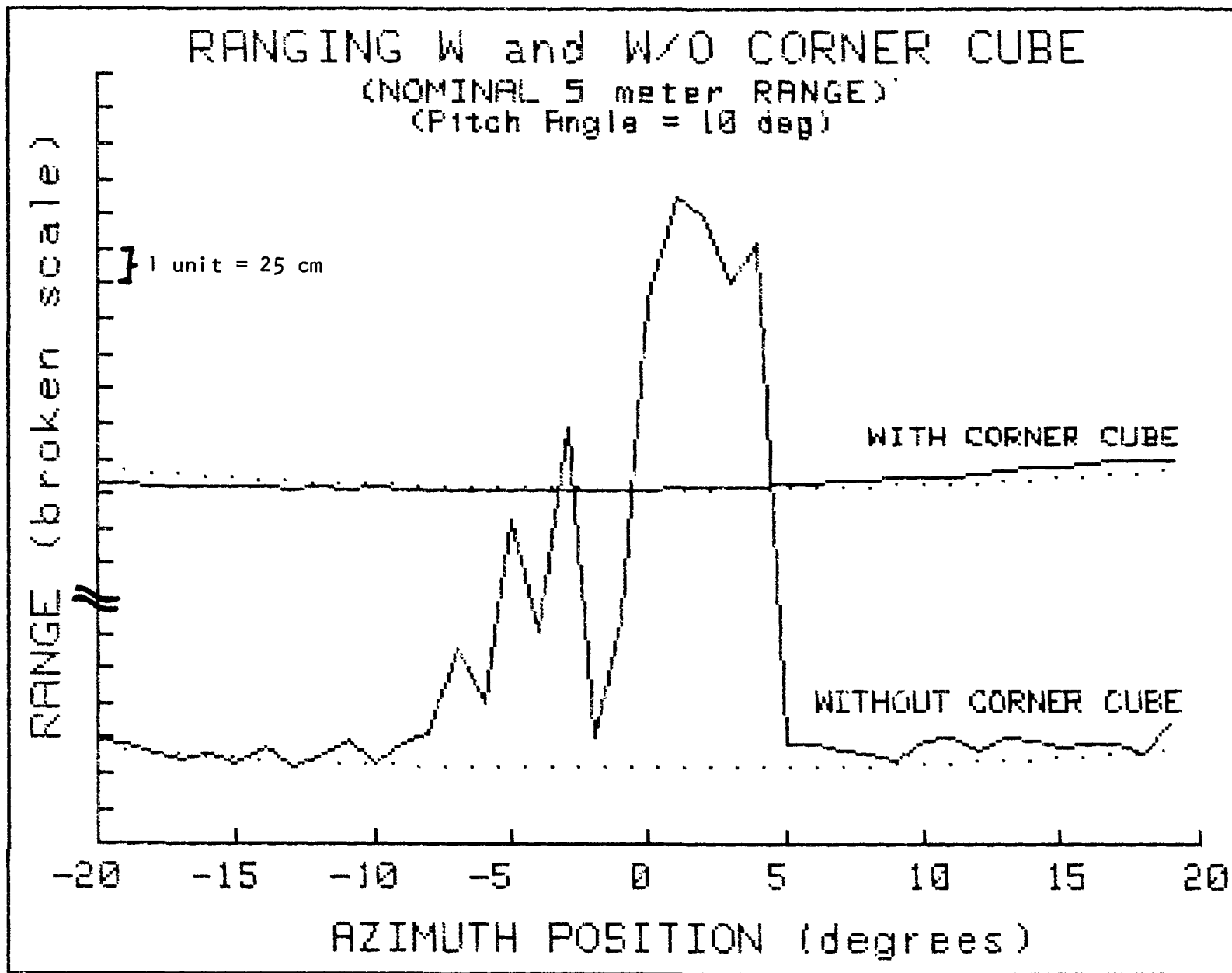

Figure 6. Five-Meter Ranging With and Without Cube Corner Reflector. (Target Pitch Angle = 10 Degrees)

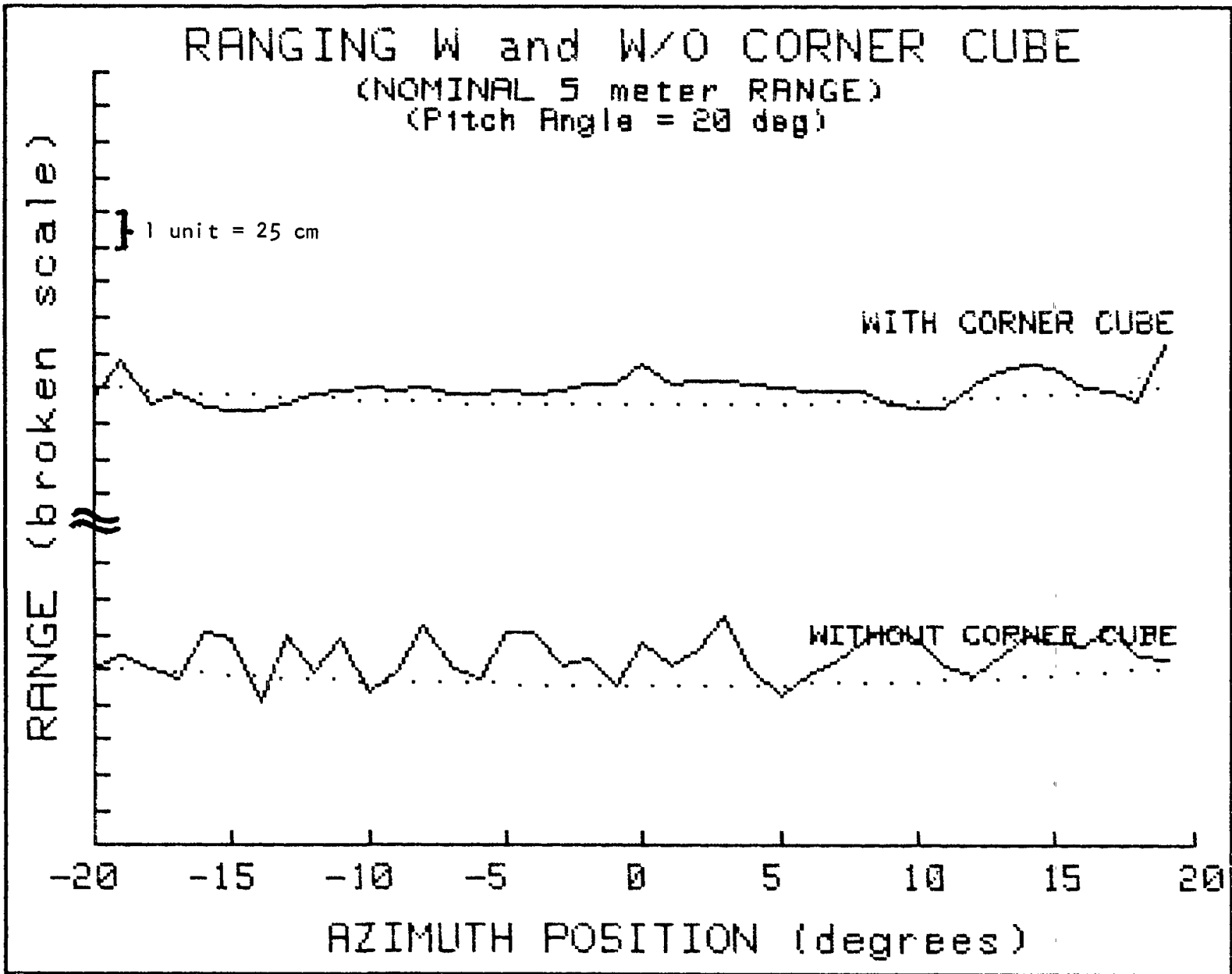

Figure 7. Five-Meter Ranging With and Without Cube Corner Reflector. (Target Pitch Angle = 20 Degrees)

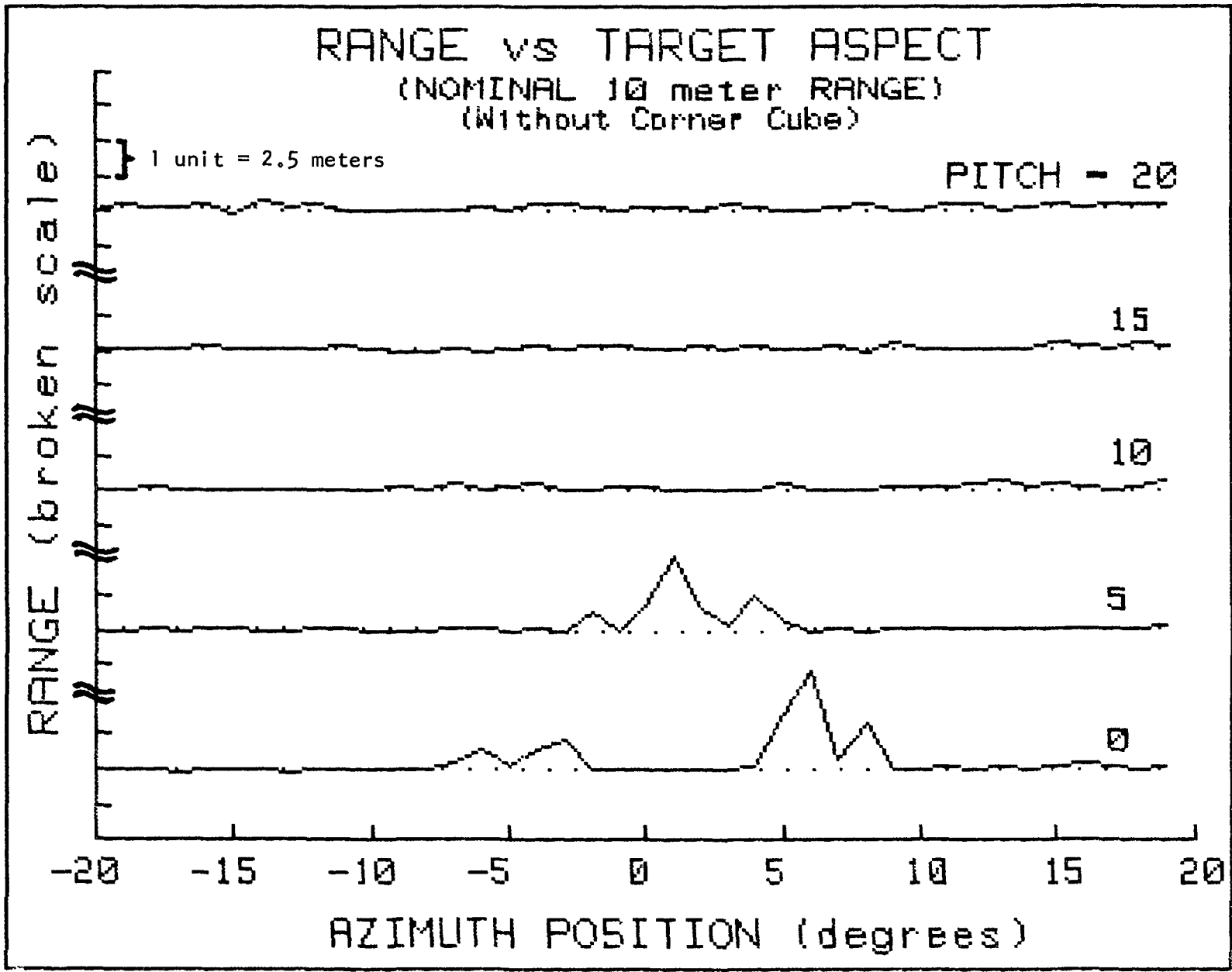

Figure 8. Range vs. Target Aspect (Nominal Range of 10 meters; WITHOUT Cube Corner Reflector).

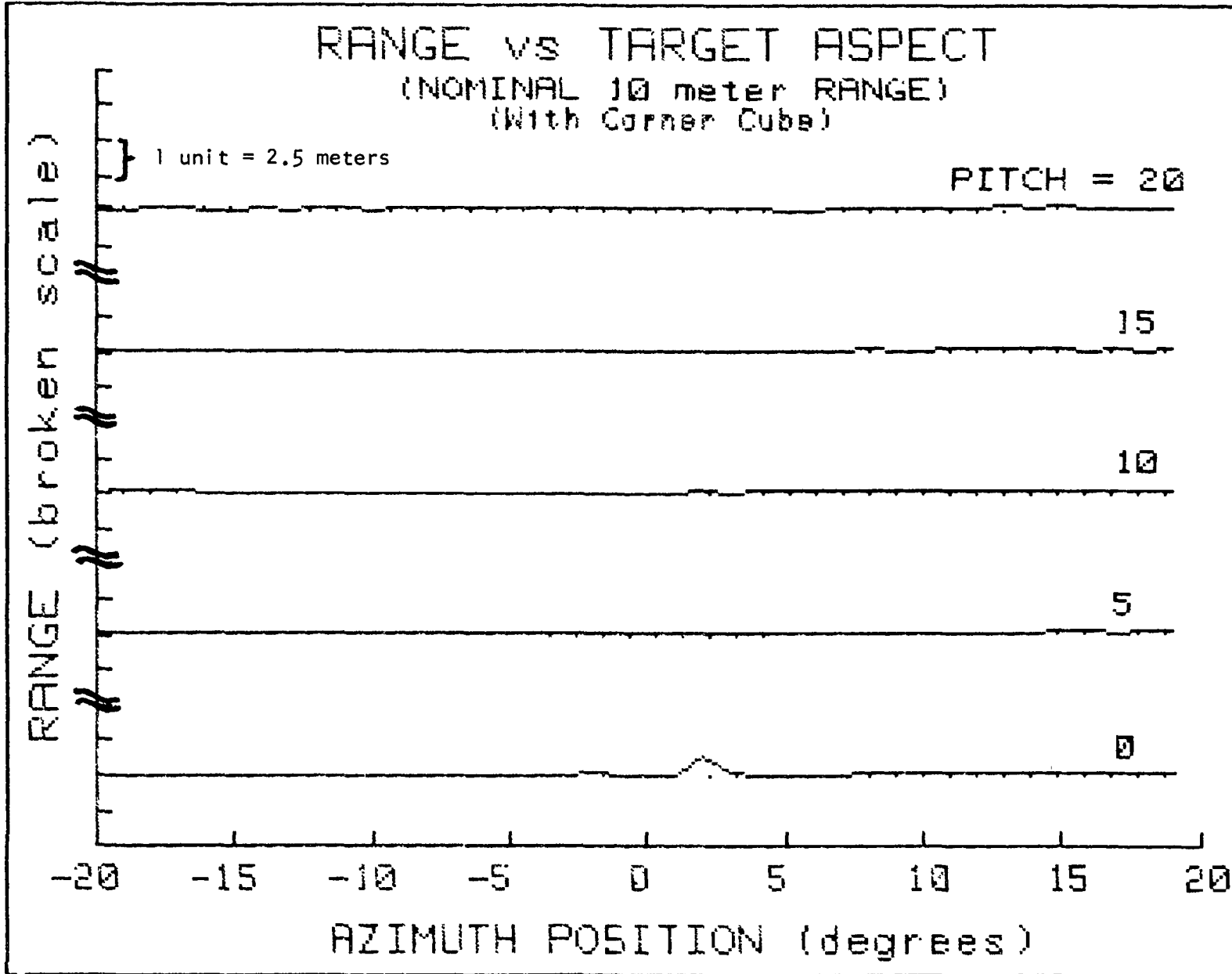

Figure 9. Range vs. Target Aspect (Nominal Range of 10 meters; WITH Cube Corner Reflector).

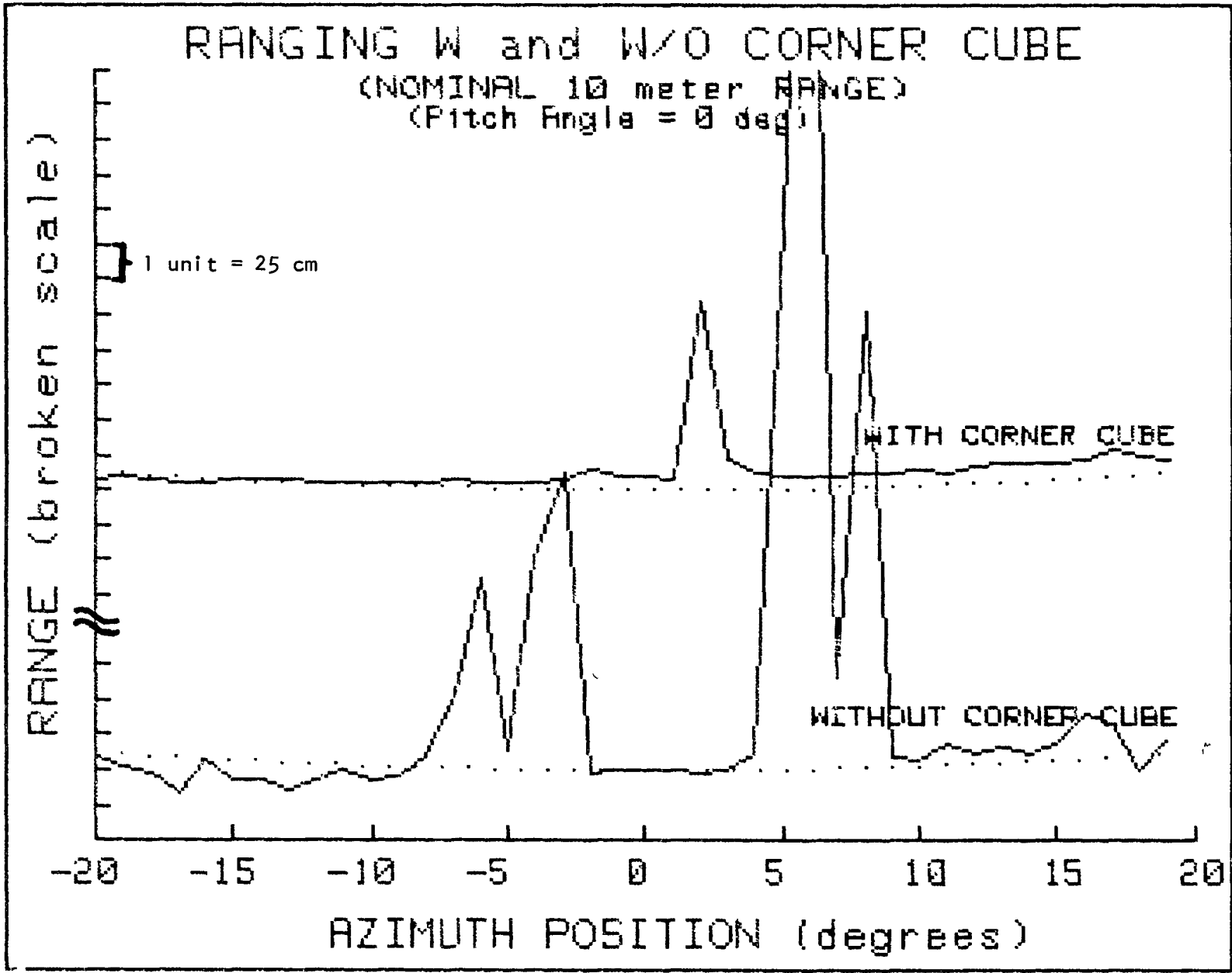

Figure 10. Ten-Meter Ranging With and Without Cube Corner Reflector. (Target Pitch Angle = 0 Degrees)

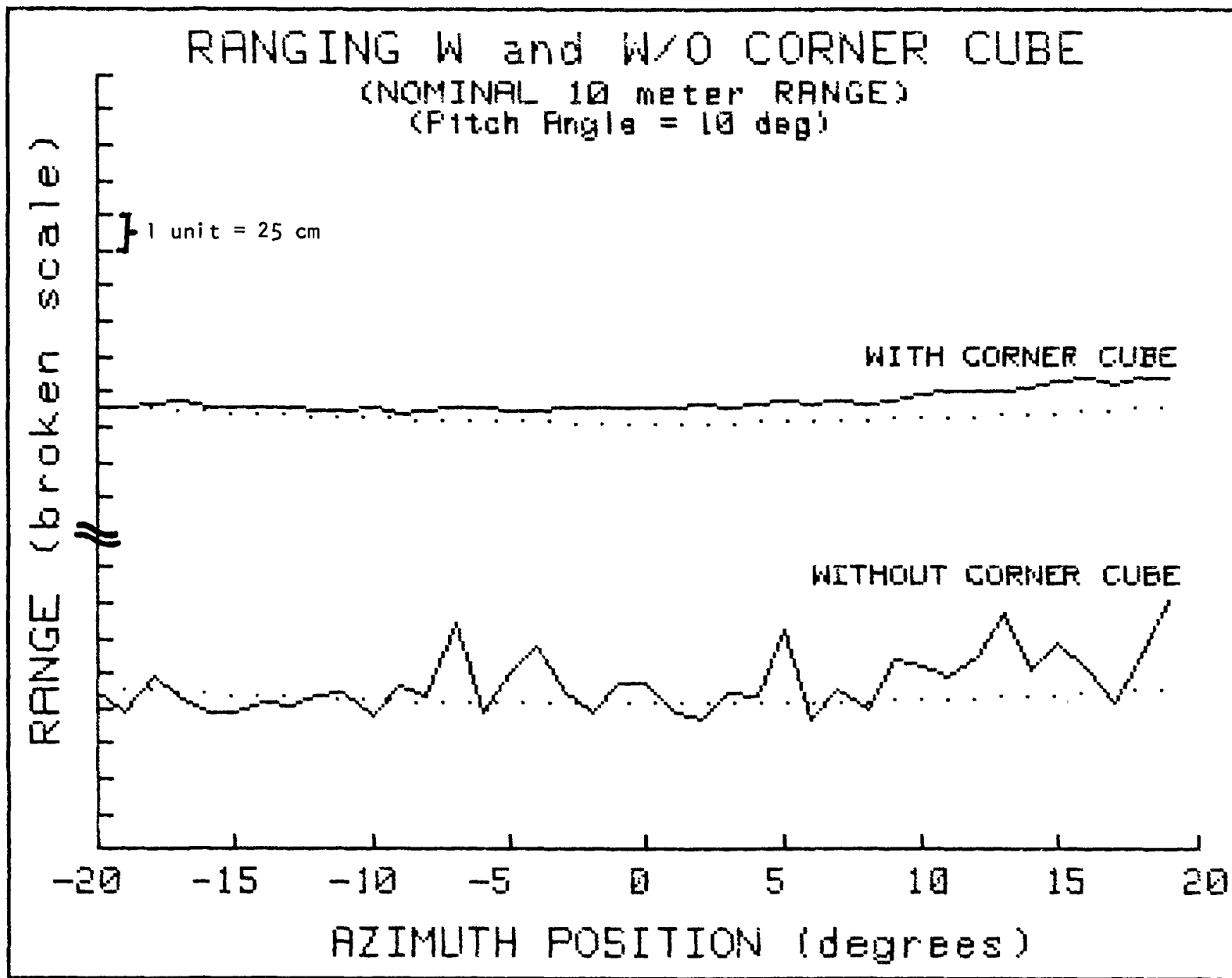

Figure 11. Ten-Meter Ranging With and Without Cube Corner Reflector. (Target Pitch Angle = 10 Degrees)

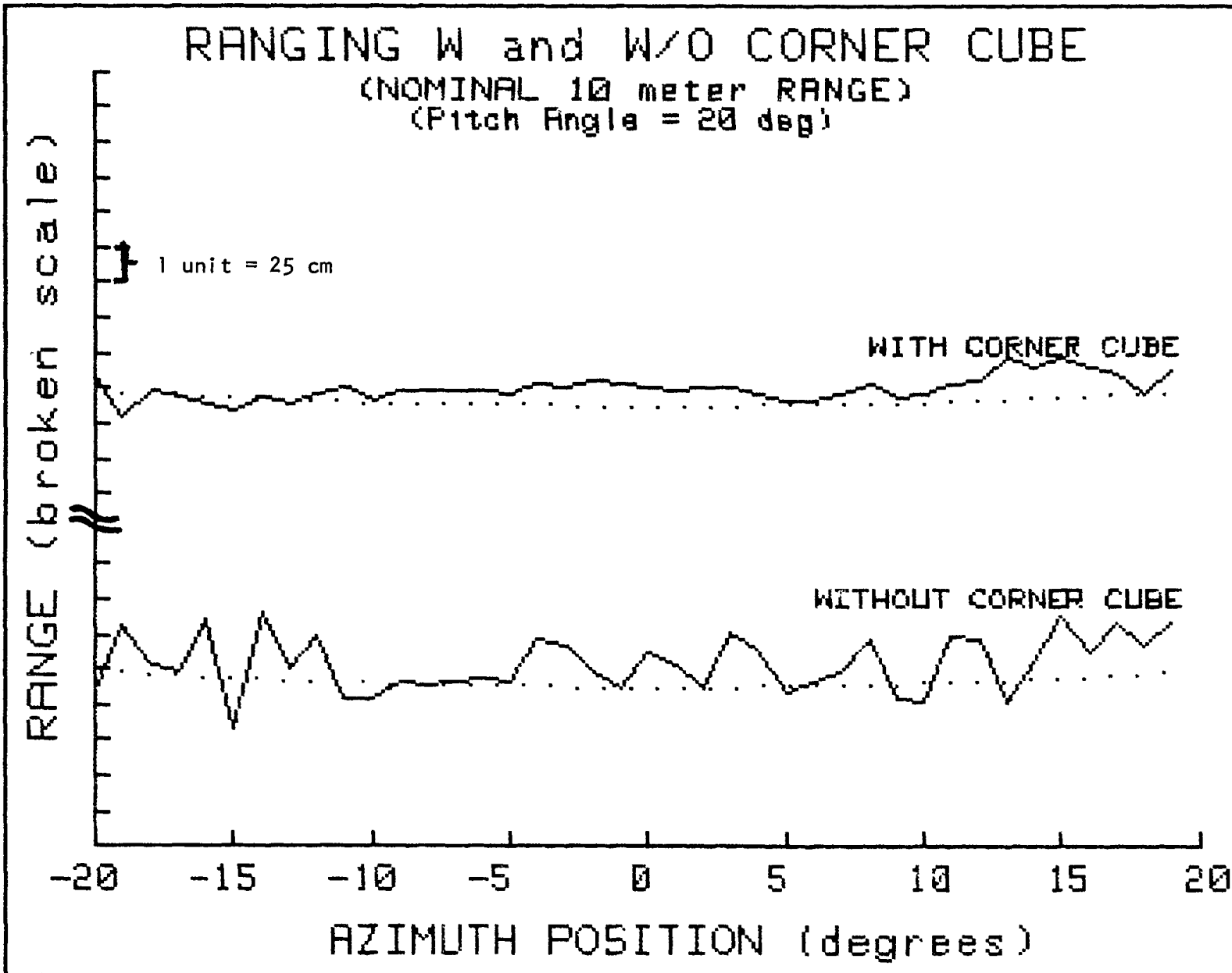

Figure 12. Ten-Meter Ranging With and Without Cube Corner Reflector. (Target Pitch Angle = 20 Degrees)

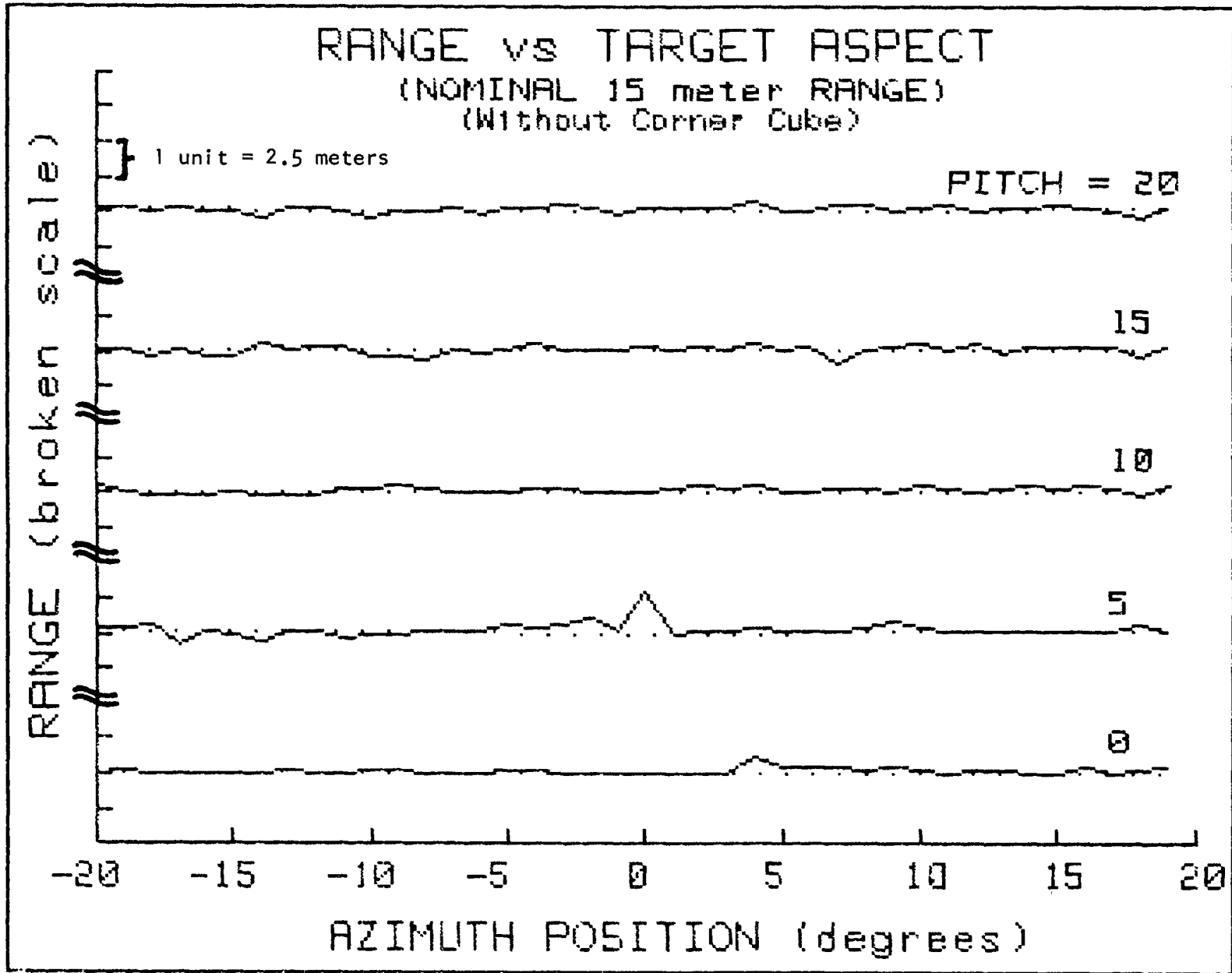

Figure 13. Range vs. Target Aspect (Nominal Range of 15 meters; WITHOUT Corner Reflector).

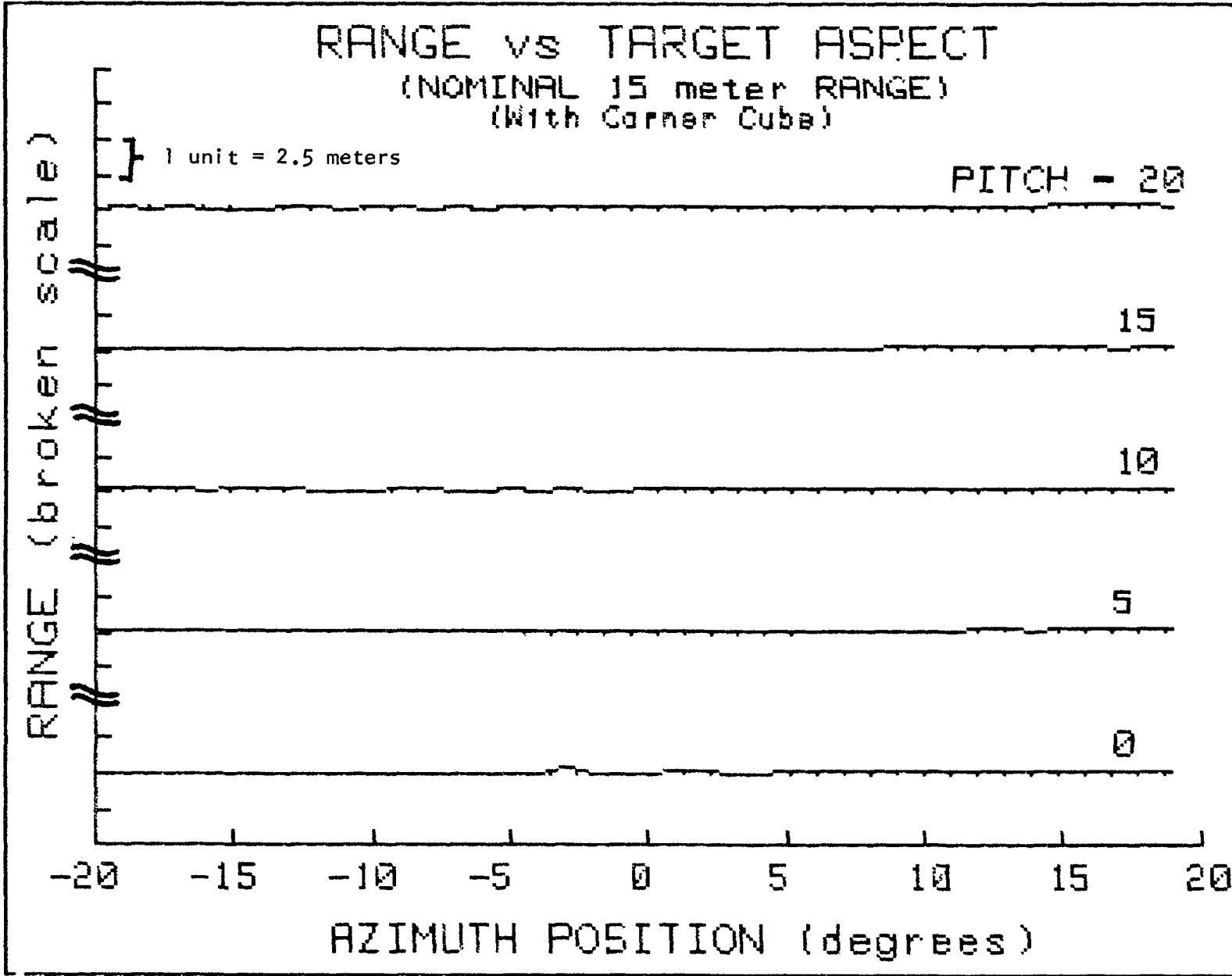

Figure 14. Range vs. Target Aspect (Nominal Range of 15 meters; WITH Cube Corner Reflector).

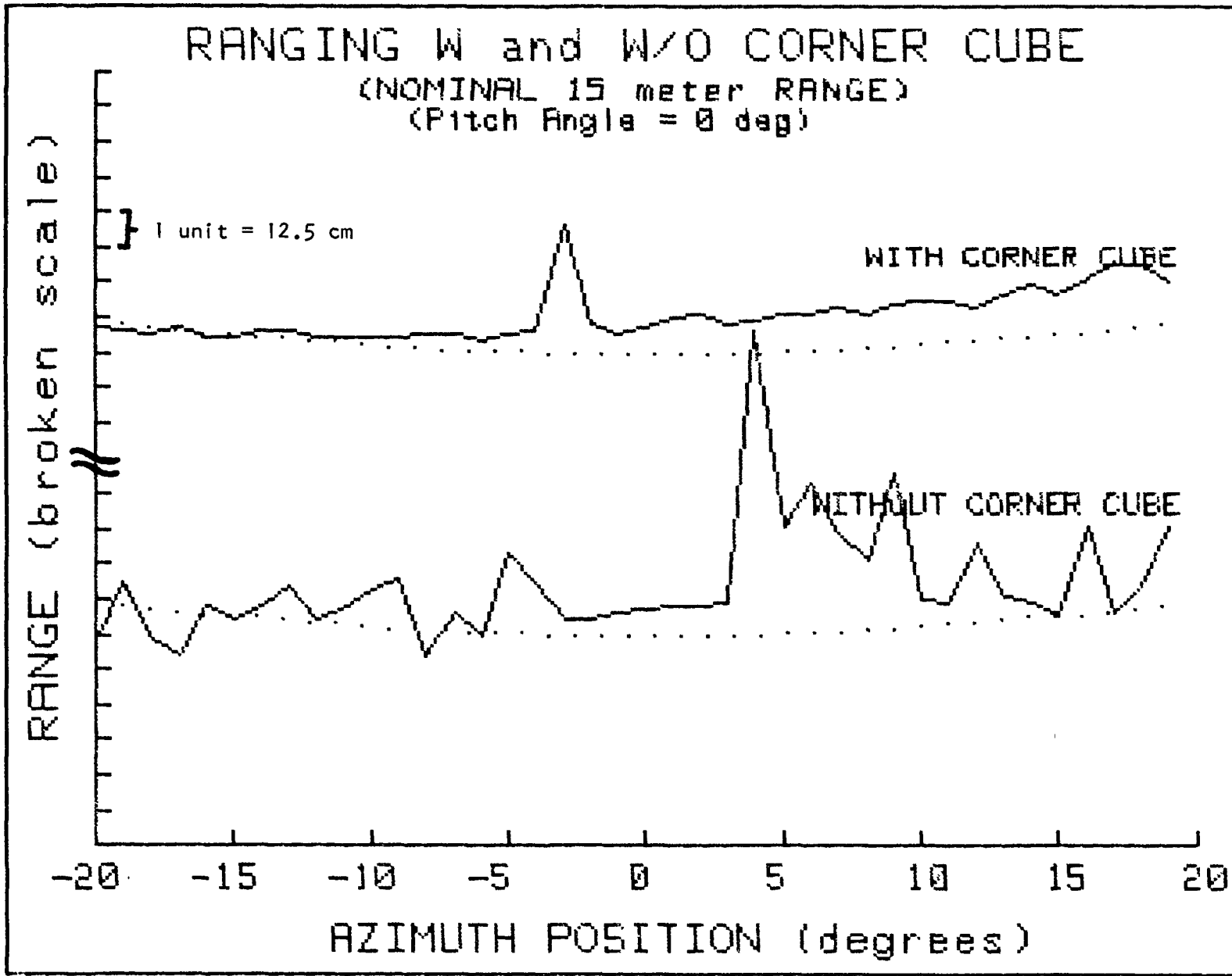

Figure 15. Fifteen-Meter Ranging With and Without Cube Corner Reflector.
(Target Pitch Angle = 0 Degrees).

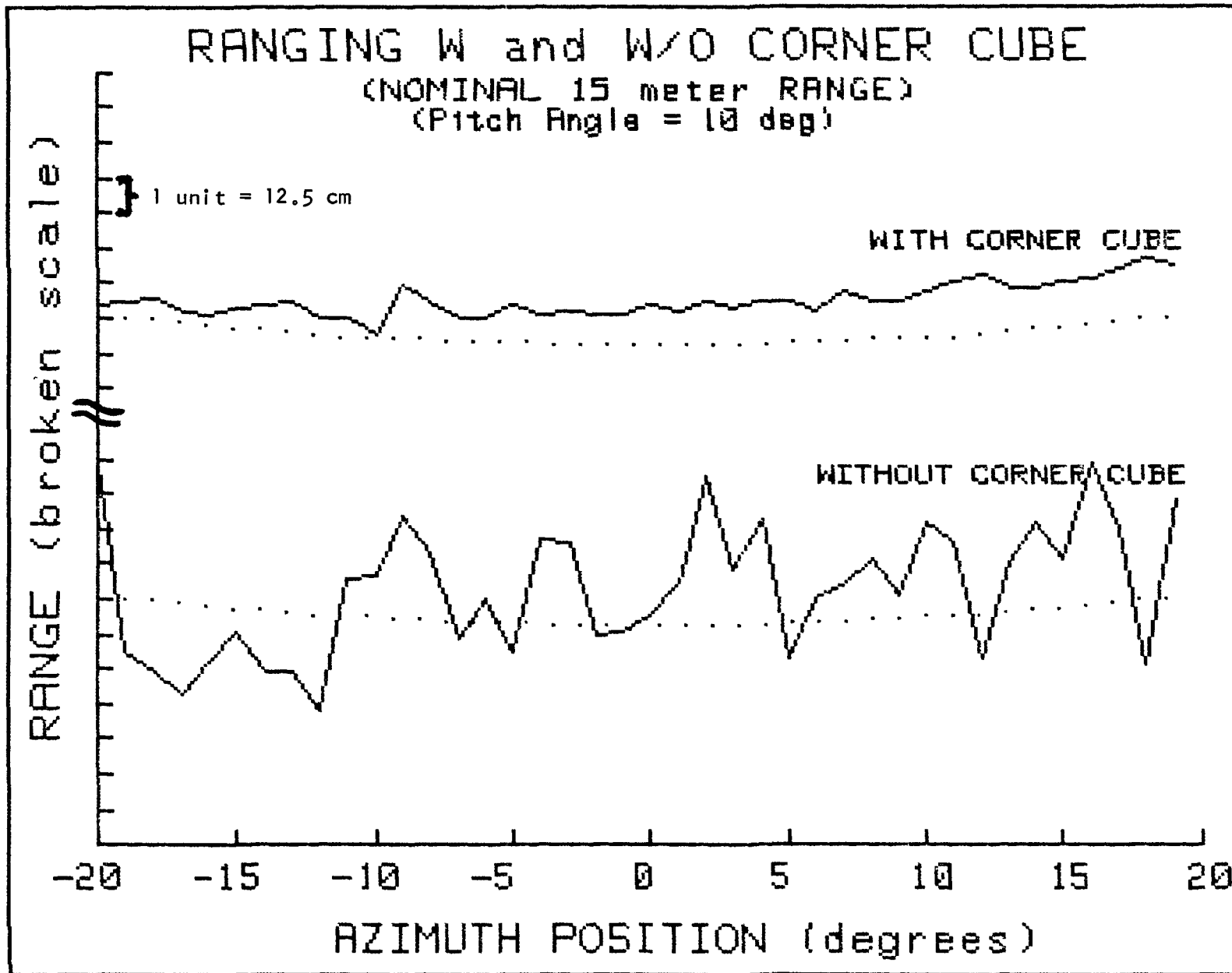

Figure 16. Fifteen-Meter Ranging With and Without Cube Corner Reflector.
 (Target Pitch Angle = 10 Degrees)

ORIGINAL PAGE IS
OF POOR QUALITY

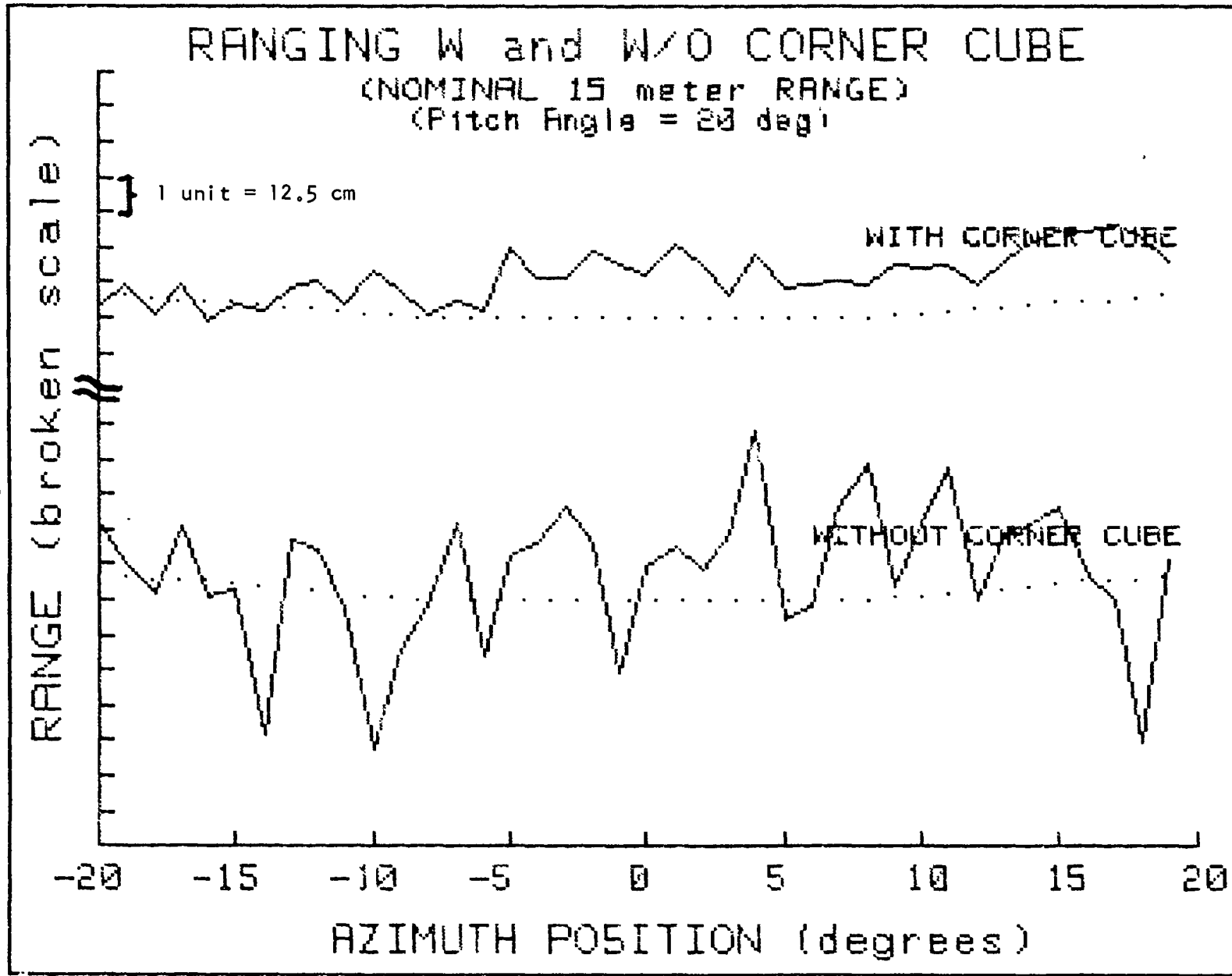

Figure 17. Fifteen-Meter Ranging With and Without Cube Corner Reflector.
(Target Pitch Angle = 20 Degrees).

XXX-25

in this series (Figs. 15-17) the range scale is expanded by a factor of twenty over the gross representations of Figs. 13 and 14. One unit on the expanded scales is equivalent to 12.5 cm.

The results of the velocity measurements are shown in Figs. 18 and 19. Figure 18 documents graphically the difficulty of measuring the closing velocity under conditions of a target rotating in position to present varying aspects to the closing vehicle. During these runs a human operator was instructed to produce randomly varying aspects by sweeping both pitch and azimuth in a range of angles within 5 degrees either side of the normal aspect. The same random variation of aspect was not repeated in the two runs depicted in Fig. 18. Note the extreme range of velocity values on the velocity scale.

To present a stark contrast, the measured velocity values in Fig. 19 indicate an accuracy with which velocity can be measured by the radar system when the target maintains a fairly stable attitude. Note that the velocity oscillations shown in each of the two separate runs over the same stretch of gantry track show peak-to-peak fluctuations of about two cm/sec, following almost identical periodicity. The periodicity is believed due to the minor lurching motion observed at the top of the gantry as the gantry is driven along on the rails below. The 20 second and 50 second time points in both Figs. 18 and 19 correspond to nominal ranges of 12 meters and 8 meters, respectively, in the middle of longer runs from 15 meters to 5 meters nominal range.

The velocity vs. time results in Fig. 19 seem to depict with a high degree of fidelity the actual relative motion between the radar and the ST model as a second-by-second function of time. This suggests a capability for resolving closing velocities with accuracies on the order of centimeters/second, remembering that the maximum allowable closing velocity for the engagement of the OMV with the ST is slightly over 3.0 cm/sec.

VI. CONCLUSION

In conclusion, this experiment has demonstrated that a cooperative target aid with high radar cross section helps immensely in measuring range and velocity. A choice of reflector superior in its properties to the cube corner is a Luneberg lens reflector, with its much wider acceptance angle. To illustrate, the 3dB-to-3dB response of the cube corner subtends only about 45 degrees whereas the similar response of a properly constructed Luneberg lens can exceed 140 degrees of acceptance angle.

Finally, in reflecting on the fact that the OMV/ST docking simulation studies with human pilots operating the docking controls, cited earlier, showed best pilot results occurred with the aid of closing velocity information provided in addition to the video information, this study has shown that the radar system provides accurate enough velocity information to support "soft" docking if the ST attitude remains relatively stable. It need not be pointed out that attitude stability is a prime design feature of the Space Telescope.

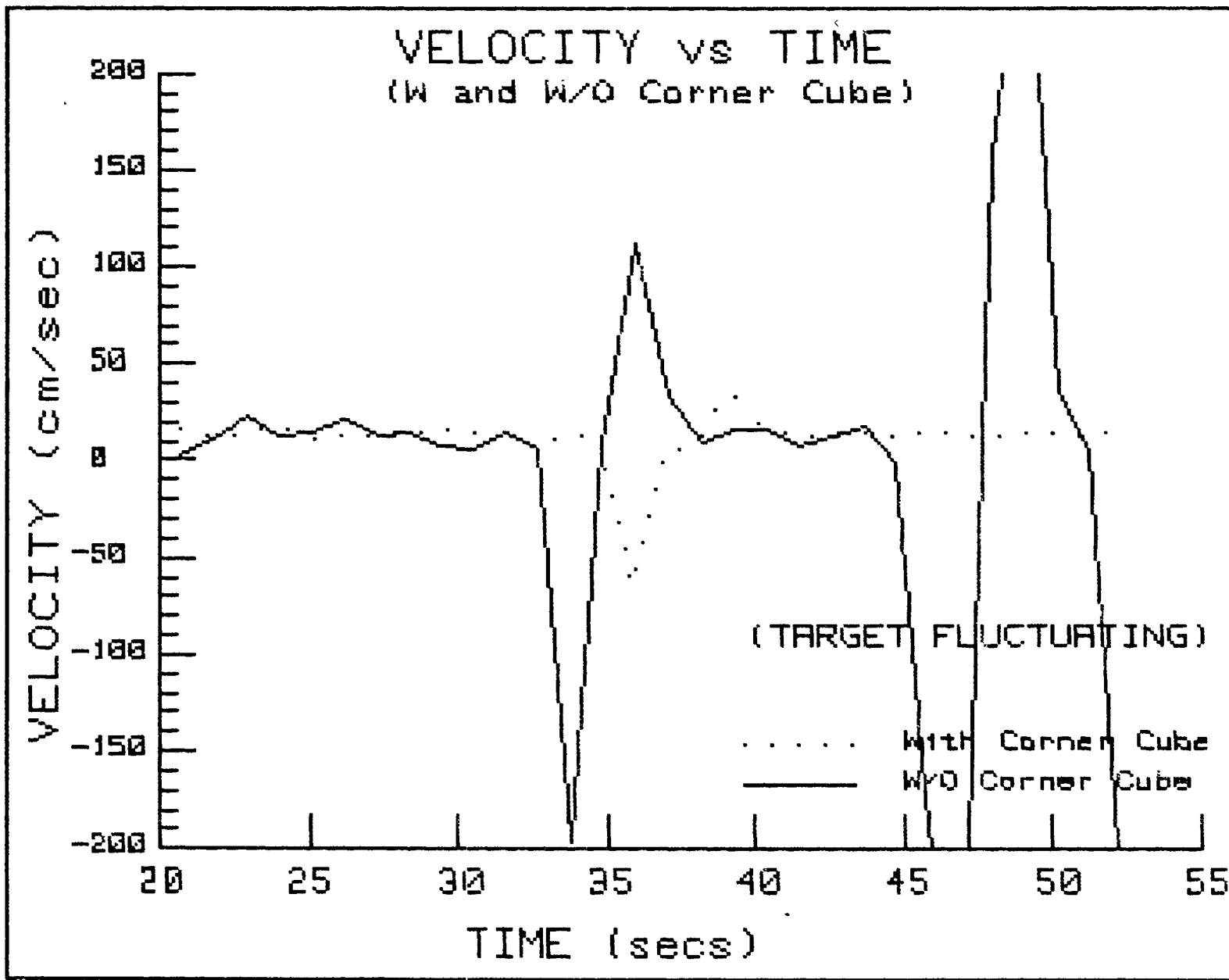

Figure 18. Velocity vs. Time With and Without Cube Corner Reflector.
(Target Aspect Fluctuating Randomly).

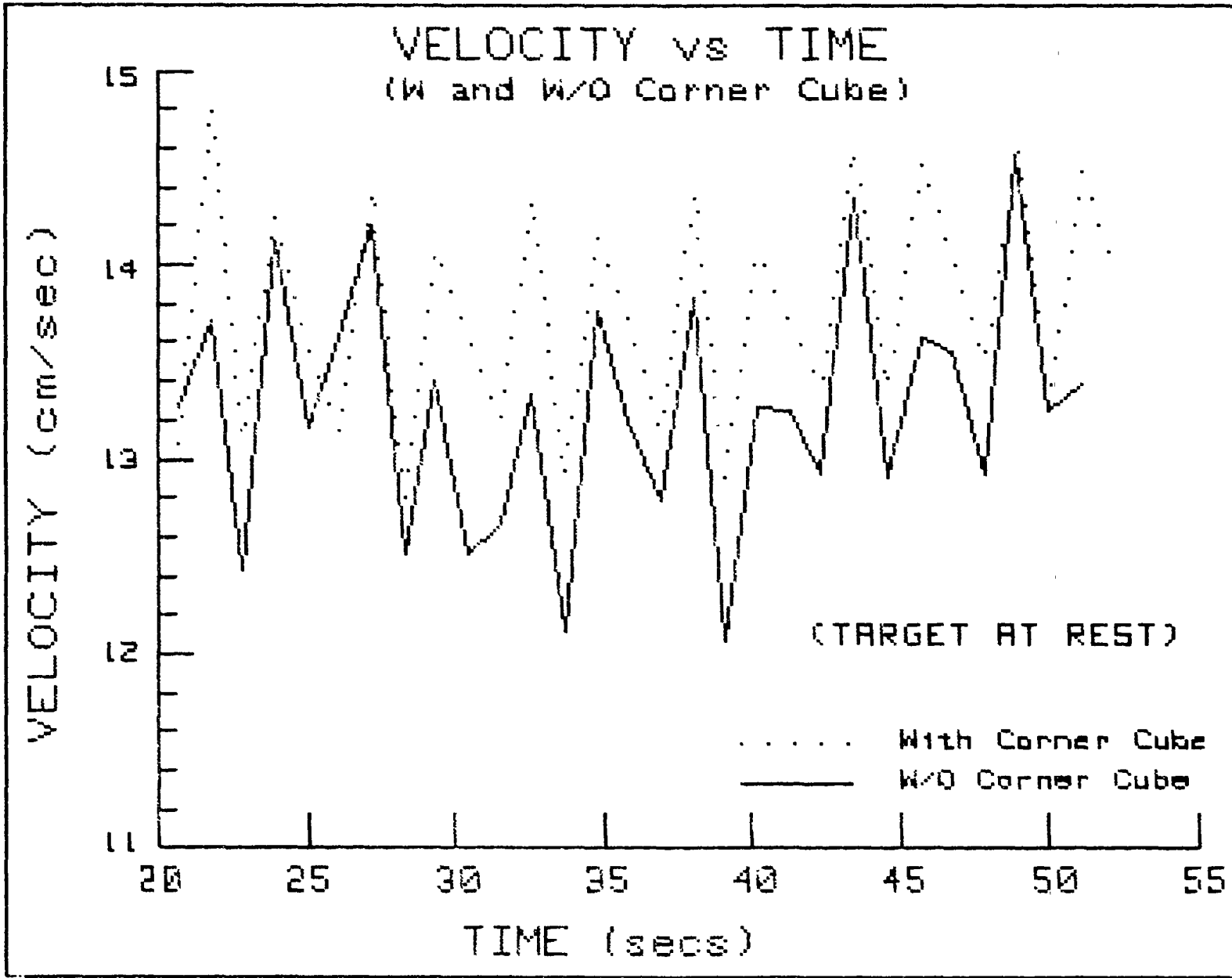

Figure 19. Velocity vs. Time With and Without Cube Corner Reflector.
(Target Aspect Stable).

REFERENCES

1. McDonald, M.W., "Study of Proposals for the Correction of Errors in a Radar Ranging Device Designed to Facilitate Docking of the Teleoperator Maneuvering System", NASA Contractor Report - 1982 NASA/ASEE Summer Faculty Fellowship Program, edited by B.F. Barfield, et al, NASA CR-162051, August, 1982.
2. McDonald, M.W., "A FMCW Radar Ranging Device for the Teleoperator Maneuvering System", NASA Contractor Report - 1983 NASA/ASEE Summer Faculty Fellowship Program, edited by G. Karr, et al, NASA CR-162051, August, 1983.
3. Bailey, J.C., "OMV/PAYLOADS INTERFACE REQUIREMENTS DOCUMENT I - SPACE TELESCOPE", Marshall Space Flight Center, NASA Internal Distribution Document: OMV IRD, Date 12/4/84, December, 1984.
4. Micheal, J.D., and F.L. Vinz, "Docking Simulation Analysis of Range Data Requirements for the Orbital Maneuvering Vehicle", NASA Technical Memorandum, NASA TM-86510, April, 1985.