

2734



FINAL REPORT

**THE DESIGN, FABRICATION AND DELIVERY
OF A MANIPULATOR FOOT RESTRAINT MOCKUP
FOR SPACE TELESCOPE DEVELOPMENT TESTING**

(NASA-CR-178837) THE DESIGN, FABRICATION AND DELIVERY OF A MANIPULATOR FOOT RESTRAINT MOCKUP FOR SPACE TELESCOPE DEVELOPMENT TESTING Final Report (Essex Corp.) 12 p
HC A02/MF A01 CSCI 05H G3/54 43474 N86-25121 Unclas

CONTRACT NAS8-36366

APRIL 11, 1986

ESSEX REPORT NO. H-86-05

FINAL REPORT

THE DESIGN, FABRICATION AND DELIVERY OF A MANIPULATOR FOOT RESTRAINT
MOCKUP FOR SPACE TELESCOPE DEVELOPMENT TESTING

NAS8-36366

Prepared For:

NATIONAL AERONAUTICS AND SPACE ADMINISTRATION
George C. Marshall Space Flight Center
Marshall Space Flight Center, Alabama 35812

Prepared By:

Michael A. Hollingsworth
ESSEX CORPORATION
690 Discovery Drive
Huntsville, Alabama 35806

April 11, 1986

H-86-05

FOREWORD

This Final Report describes work performed under contract NAS8-36366 which involved design, fabrication and delivery of a Manipulator Foot Restraint (MFR) for the Marshall Space Flight Center (MSFC) Neutral Buoyancy Simulator (NBS).

Essex Corporation appreciates the opportunity to have developed the MFR under this competitively acquired contract and looks forward to serving NASA on future contracts.

TABLE OF CONTENTS

	<u>Page</u>
FOREWORD	i
ACRONYMS AND ABBREVIATIONS	iii
1.0 INTRODUCTION	1
1.1 Background	1
2.0 TECHNICAL APPROACH	2
2.1 Review of Manipulator Foot Restraint Concept Drawings	2
2.2 Preparation of Mockup Drawings	2
2.3 Fabrication and Assembly of Mockup	2
3.0 END ITEM DESCRIPTION	4
3.1 Grapple Fitting	4
3.2 Horizontal Stanchion	4
3.3 Rotatable Foot Restraint Platform	4
3.4 Rotatable/Tiltable Stanchion	4
3.5 Rotatable Tool Carrier and Tool Boards	5
3.6 Payload Interface Mechanism (PIM)	5
4.0 CONCLUSIONS AND RECOMMENDATIONS	7
4.1 Conclusions	7
4.2 Recommendations	7

LIST OF FIGURES

Figure 1: MFR Major Subsystems	6
--------------------------------	---

ACRONYMS AND ABBREVIATIONS

- A7LB - Apollo Extravehicular Activity Pressure Suit
- COR - Contracting Officer's Representative
- EMU - Extravehicular Mobility Unit (Space Shuttle Pressure Suit)
- EVA - Extravehicular Activity
- GFE - Government Furnished Equipment
- HST - Hubble Space Telescope
- MFR - Manipulator Foot Restraint
- MSFC - Marshall Space Flight Center
- NASA - National Aeronautics and Space Administration
- NBS - Neutral Buoyancy Simulator
- ORU - Orbital Replacement Unit
- PIM - Payload Interface Mechanism
- PVC - Polyvinyl Chloride
- RMS - Remote Manipulator System

1.0 INTRODUCTION

1.1. Background

The Manipulator Foot Restraint (MFR) is a subsystem of the Remote Manipulator System (RMS). This system will play a major role in servicing the Hubble Space Telescope (HST) on orbit. Mounted on the RMS, the MFR is the primary workstation for extravehicular activity (EVA) tasks. The MFR is used for transportation of all orbital replacement units (ORUs) from the ORU spares carrier to the HST aft shroud and equipment sections. The MFR is also the primary crew restraint/translation fixture for all HST maintenance and repair tasks.

In fulfilling the hardware development and crew training objectives of the MFR neutral buoyancy mockup, the following components listed below were provided:

- 1) MFR neutral buoyancy mockup that is totally functional with flight-type crew interfaces;
- 2) RMS interface (grapple fixture) that is compatible with the Marshall Space Flight Center (MSFC) RMS Neutral Buoyancy Simulator (NBS);
- 3) Foot restraint plates compatible with both the "EMU" and "A7LB" pressure suits;
- 4) Movable stanchion with both tool carrier interfaces;
- 5) Payload interface mechanism; and
- 6) Total neutralization capability for the MFR using accepted methods.

The following sections describe the end items listed above in more detail, with recommendations for future use of the trainer.

2.0 TECHNICAL APPROACH

In fulfilling contract responsibilities, Essex performed the three tasks described below.

2.1 Review of Manipulator Foot Restraint Concept Drawings

At the onset of the contract, Essex received documentation and drawings of the MFR. This documentation was reviewed to determine fabrication techniques, processes, and materials to be used, and to define missing information and discrepancies which may have occurred due to design changes or other reasons. Drawings and information which had not yet been received or for which clarification was required were requested from the Contracting Officer's Representative (COR).

2.2 Preparation of Mockup Drawings

As drawings were received from NASA, Essex designers discussed possible concepts with the COR. Concept sketches of the MFR were then prepared and presented to the COR for approval. Approved engineering drawings and red lined drawings of mockup parts were prepared.

2.3 Fabrication and Assembly of Mockup

The approved engineering drawings of the MFR developed in task 2.2 were submitted to the Essex machine shop. The parts were fabricated with materials and techniques best suited for simulations in the underwater environment of the MSFC NBS.

The primary fabrication material for the mockup was 6061-T6 aluminum with 5052-H32 aluminum used where a bent sheet or plate was needed. All fasteners were either stainless steel rivets or stainless steel bolts with brass nuts to prevent galling. Bronze was used on bearing surfaces because of its resistance to corrosion and low coefficient of friction.

Fabrication techniques reflected fidelity needs of the MFR. For instance, areas with crew interfaces were machined to accurately represent the flight hardware. Areas requiring only volumetric representation of a hardware item were fabricated of aluminum sheet and/or angle. Corners and edges of all parts were radiused to meet standards in MSFC-STD-512A.

When the major MFR parts were completed, they were assembled for a fit check. After verification that all mechanisms functioned properly, the MFR was disassembled and parts were given surface finish treatment. Surface finish of the parts included hard anodizing and painting with white Plasite according to MSFC NBS specifications.

The MFR was then reassembled and the COR approved it for delivery. Upon delivery to the NBS, the MFR was neutralized using PVC tubes and foam. With the neutralization complete, all mechanisms and crew interfaces were tested to verify proper operational characteristics.

3.0 END ITEM DESCRIPTION

The MFR mockup supplied by Essex represents all of the components of the flight hardware. A detailed description of the hardware is given below. Refer to Figure 1 for the location of components on the MFR.

3.1 Grapple Fitting

The grapple fitting represents the flight version volumetrically. The fitting interfaces and is compatible with the RMS at the MSFC NBS. A grab plate was added to aid in locking the RMS to the grapple fitting.

3.2 Horizontal Stanchion

The horizontal stanchion is a volumetric component. Its structure is a rigid aluminum angle frame with .090 aluminum skin riveted to it. It is painted with white Plasite paint to MSFC NBS specifications.

3.3 Rotatable Foot Restraint Platform

The rotatable foot restraint platform is similar in construction to the flight version. High fidelity is found in the areas of expected crew interface. Only machined pockets were omitted where crew interfaces were not affected. The foot restraint plates are compatible with both the "EMU" and "A7LB" pressure suits.

3.4 Rotatable/Tilttable Stanchion

The rotatable/tiltable stanchion is generally high fidelity. Movement and operations and volume are representative of the flight-version MFR. Mockup peculiar construction techniques were used where necessary to aid in the serviceability of the component.

3.5 Rotatable Tool Carrier and Tool Boards

The tool carrier and tool boards have the same rotation capability as the flight component. The carrier is high fidelity in all areas of crew interface. The component has flight movement and forces on all mechanisms. The shape is volumetrically correct with construction cost and serviceability considered.

3.6 Payload Interface Mechanism (PIM)

The PIM is flight-like in all areas of crew interface. All mechanisms are high-fidelity with flight-like operations and forces. The component is similar in construction to the flight-version PIM with accurate volumetric representation. The Government Furnished Equipment (GFE) tether reel was not incorporated into the PIM because it was unavailable.

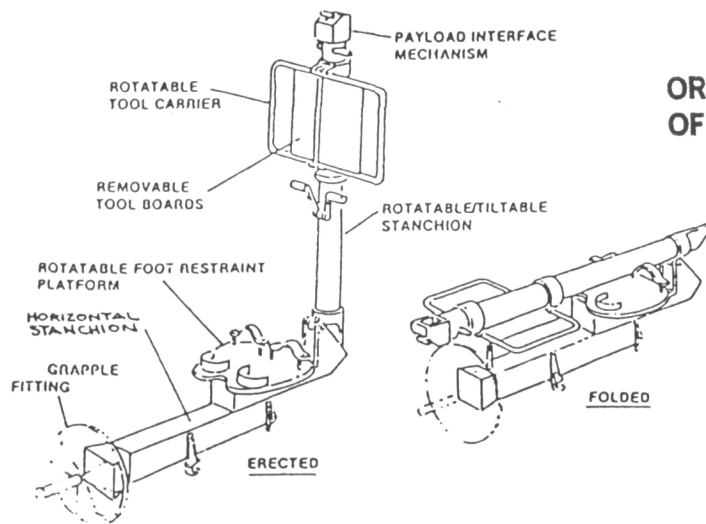
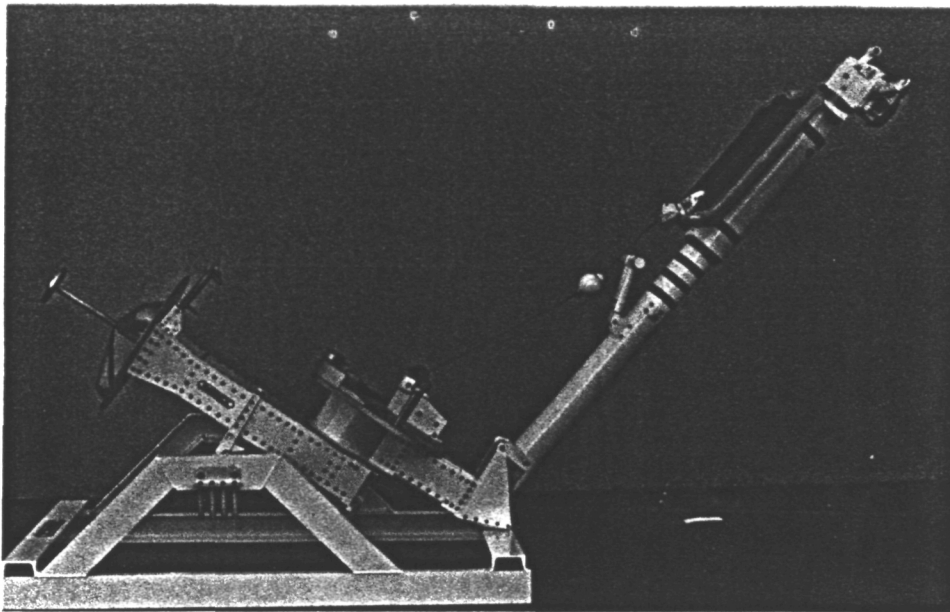

ORIGINAL PAGE IS OF POOR QUALITY

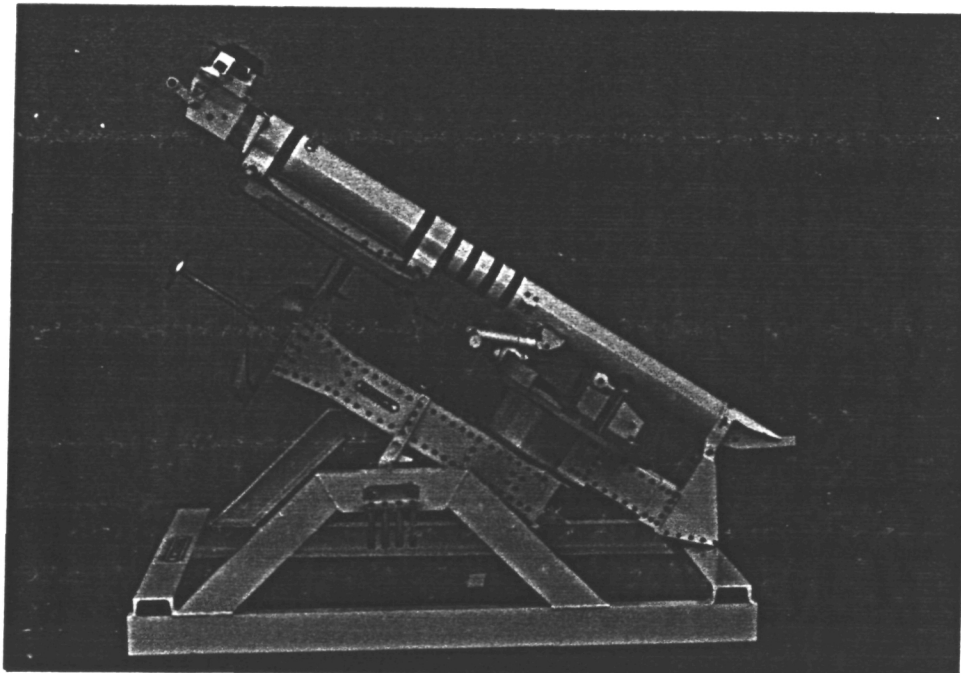

Figure 1: MFR Major Subsystems

4.0 CONCLUSIONS AND RECOMMENDATIONS

The following conclusions and recommendations are based on principles, procedures and methods of application used during this endeavor.

4.1 Conclusions

Flight drawings were redlined and used to construct the MFR to guarantee that mockup components were functionally equivalent to the flight MFR. Material surface finishes and tolerances that are compatible to the NBS environment were used.

4.2 Recommendations

This high-fidelity MFR must be treated differently than the low-fidelity MFR because of its flight-type mechanisms. If a maintenance and operations procedure is followed, the down time for repair on the high-fidelity MFR will be minimized. This procedure is described below.

Lifting the MFR in and out of the NBS requires two men on deck and two in the water. After a test the MFR should be taken out of water and placed on its stowage rack. While the MFR is on the stowage rack, it should be washed thoroughly inside and out with fresh water. All mechanisms, cables, bolts, and nuts should be visually inspected. Periodic lubrication of all moving parts is necessary to prevent the moving parts from locking up.