

FLIGHT EVALUATION OF A HYDROMECHANICAL BACKUP CONTROL
FOR THE DIGITAL ELECTRONIC ENGINE CONTROL SYSTEM IN AN F100 ENGINE

Kevin R. Walsh and Frank W. Burcham
NASA Ames Research Center
Dryden Flight Research Facility
Edwards, California

SUMMARY

The backup control (BUC) for the DEEC system is a simple hydromechanical system provided in the event a major malfunction occurs in the DEEC. The DEEC detects and accommodates engine faults in real time by using digital computation electronics which sustains full authority control over all the engine-controlled variables.

This paper will describe the BUC features, the operation of the BUC system, the BUC control logic, and the BUC flight test results. The flight test results included: transfers to the BUC at military and maximum power settings; a military power acceleration showing comparisons between flight and simulation for BUC and primary modes; steady-state idle power showing idle compressor speeds at different flight conditions; and idle-to-military power BUC transients showing where compressor stalls occurred for different ramp rates and idle speeds. All the BUC transfers which have occurred during the DEEC flight program were initiated by the pilot. There were no automatic transfers to the BUC.

BUC FEATURES

The hydromechanical BUC for the DEEC is a simple system designed for safety purposes. The main purpose of its operation is returning to base and landing. The DEEC will automatically transfer to the BUC when one of the following occurs:

- (1) a fault is detected that could damage the engine;
- (2) a DEEC power failure occurs; or
- (3) at the pilot's discretion.

Other BUC features include:

(1) operation over the entire F100 operating envelope, which includes the F-15 flight envelope as shown in the next figure. Also shown, for comparison, is the F-16 BUC envelope. The F-16 BUC is less complex and has fewer capabilities than the F-15 BUC;

- (2) intermediate thrust at least 70 percent of DEEC intermediate thrust;
- (3) automatic airstart capability;
- (4) no augmentation;
- (5) closed nozzle; and
- (6) throttle rate limited.

For the DEEC tests the throttle rate was limited by the pilot. The evaluation of different throttle rates helped Pratt and Whitney Aircraft decide on a rate limiter for a future BUC. This rate limiter is a part of the group III logic and will be 5 sec for an idle-to-military throttle transient.

BUC Envelopes

NASA
DFRF83-519

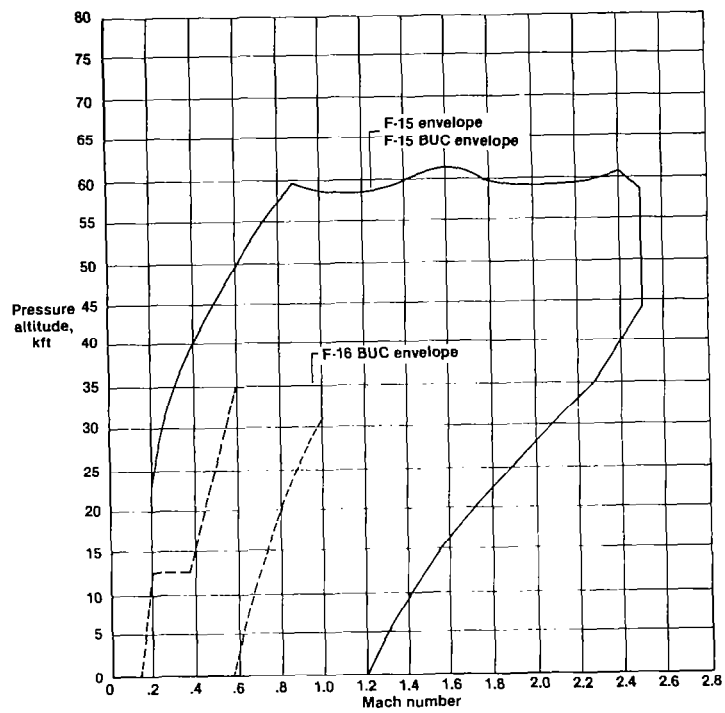

BUC SYSTEM DESCRIPTION

The dashed lines shown in the block diagram of the DEEC system represent the BUC system. The BUC is housed in the same package as the DEEC gas generator fuel-metering valves. A hydraulically operated transfer valve is positioned so the BUC components will control the following:

- (1) gas generator fuel flow (WFGG) to the main (core) burner;
- (2) the position of the start bleeds; and
- (3) the position of the core compressor variable vanes (RCVV).

The BUC operates on the following inputs:

- (1) fan inlet static pressure (PS2);
- (2) fan inlet total temperature (TT2);
- (3) power lever angle (PLA); and
- (4) RCVV feedback cable indicating RCVV position.

DEEC Control System Block Diagram

NASA
DFRF83-319

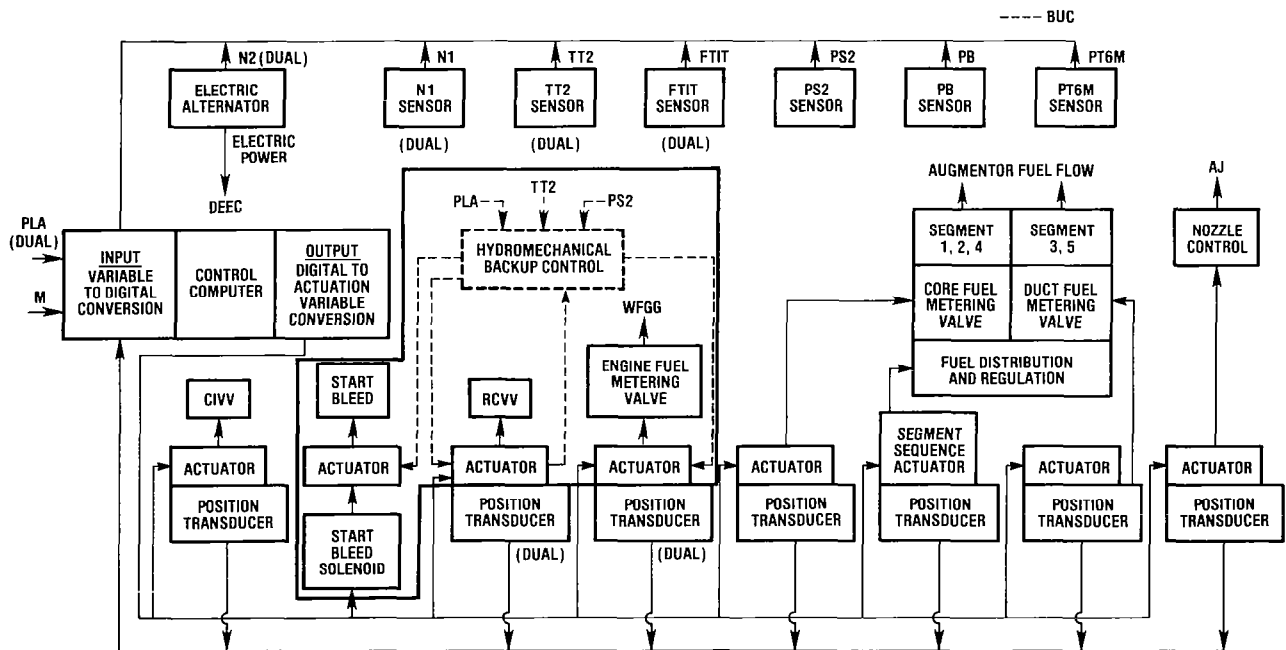

BACKUP CONTROL LOGIC

A diagram of how the BUC implements the input variables to obtain metered fuel flow (WFGG) and RCVV position is shown in the figure below. Fuel-air ratio in the form of WF/PS2 is derived from a cam that moves as a function of PLA and TT2. This WF/PS2 value and PS2 is fed to a different cam that outputs a corrected value of PS2 called compensated fan inlet static pressure (PS2C). A multiplier cam then multiplies the PS2C value and the WF/PS2 ratio to obtain the WFGG. The RCVV position is derived from a cam that moves as a function of PLA and TT2.

The gas generator control/BUC also provides the following functions when in BUC:

- (1) a fuel pressure mode signal (PFMO), indicating BUC operation is supplied to the augmentor control and the nozzle control to cancel augmentation and to close the engine nozzle;
- (2) a null voltage, supplied to the CIVV torque motor, drives the CIVVs to their full cambered position; and
- (3) an electrical signal supplied to the cockpit to indicate BUC operation.

In addition, there are no fan rotor speed (N1), core rotor speed (N2), or fan turbine inlet temperature (FTIT) inputs to the BUC.

Backup Control Logic

NASA
DFRF83-425

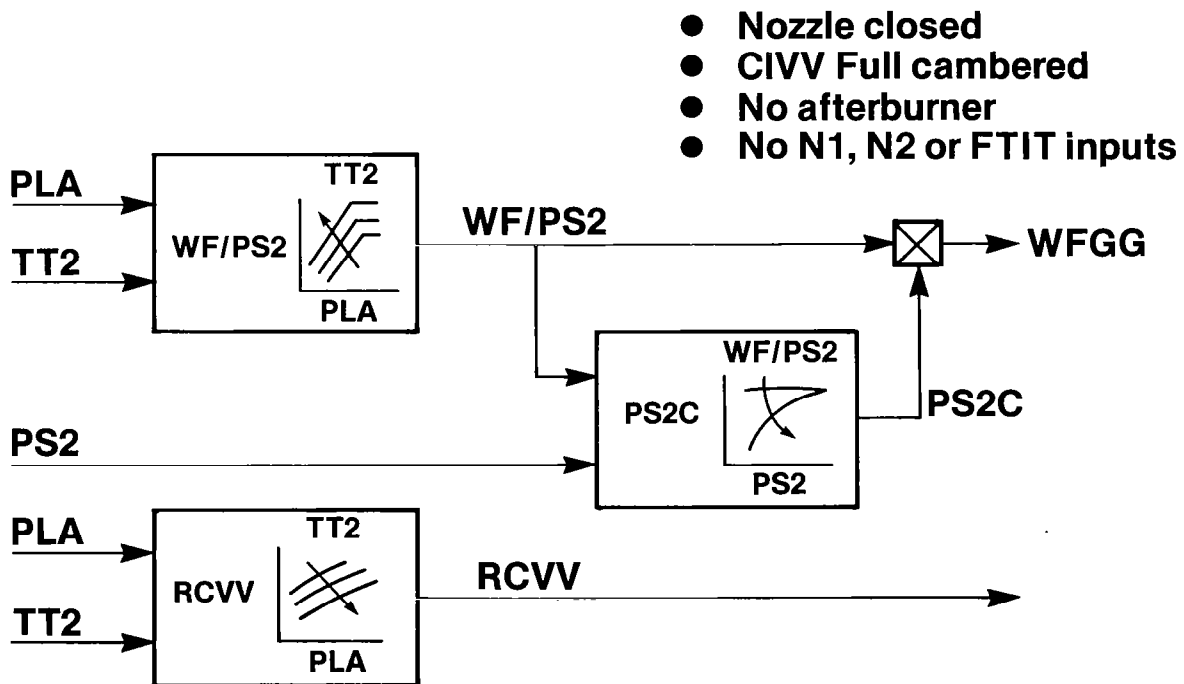

BUC TRANSFERS

The BUC transfer points that were accomplished are shown in the figure below. One hundred twenty-five BUC transfers were successful, including the transfers at maximum power and at ground level.

BUC Transfers

NASA
DFRF83-520

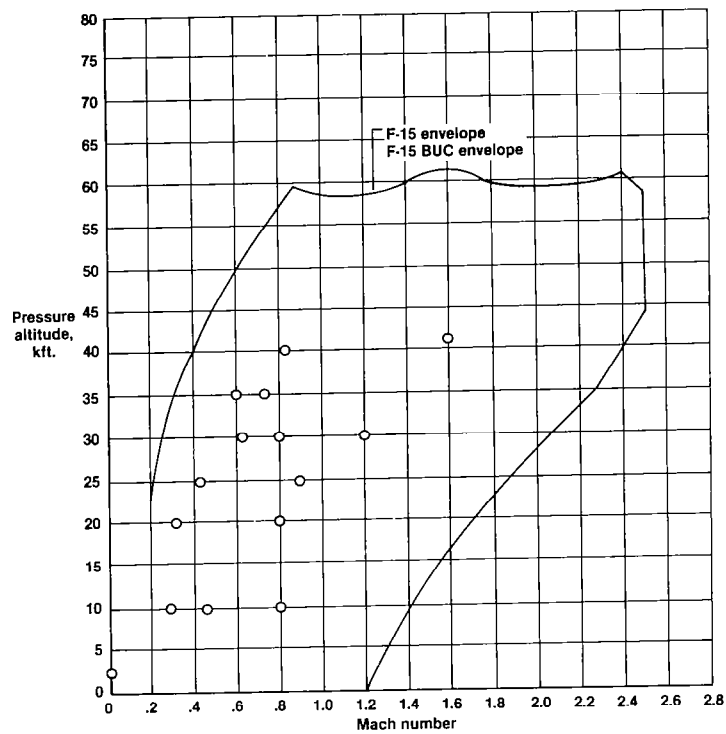

BUC TRANSFER, MILITARY POWER

The next figure is a time history of a BUC transfer at military power, at Mach 0.6 and 30,000 ft. The BUC transfer was initiated by the pilot at $t = 4.2$ sec, as indicated by the rise in PFMO. At that time, the CIVV torque motor received a null voltage which drove the CIVVs to full cambered position. The jet primary nozzle area (AJ) torque motor received the fuel pressure mode signal (PFMO), which fully closed the nozzle. Because the BUC gas generator fuel flow schedule requested a lower fuel flow than the DEEC, the fuel flow decreased at transfer. The RCVVs were also scheduled to new positions.

After a small delay, burner pressure and fan turbine inlet temperature began to respond to the fuel flow decrease. Also, a time lag occurred for N1 and N2 to register the transfer because of the slow scheduling of the variable vanes and the large angular momentum of the fan and compressor. For this military power BUC transfer, N1 and N2 speeds decreased only slightly.

BUC Transfer

Military Power

30,000 Ft, M = 0.6

NASA
DFRF83-526

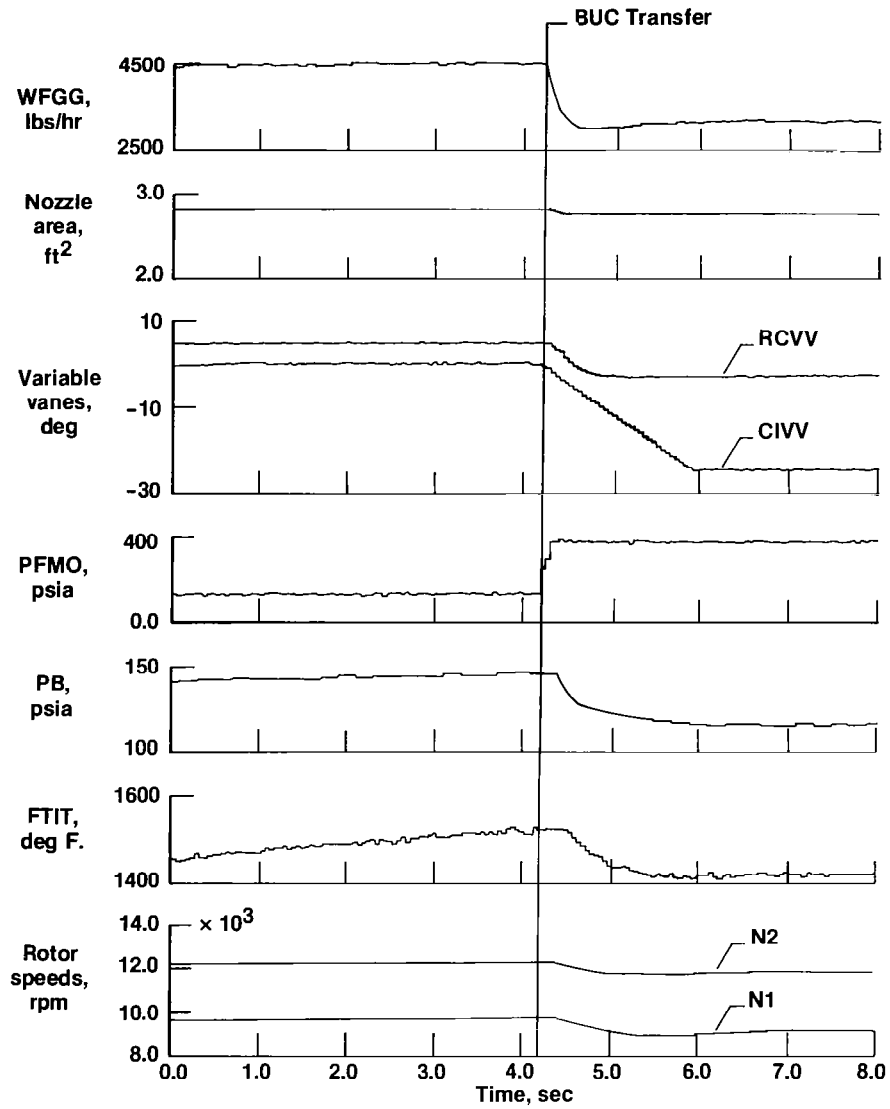

BUC TRANSFER, MAXIMUM POWER

A time history of a BUC transfer at maximum power, and Mach 1.2 at 30,000 ft is presented in the following figure. The same sequence of events occur as for the military power transfer. The BUC transfer occurred at $t = 1.5$ sec as indicated by the rise in PFMO. The CIVV torque motor received a null voltage, which drove the CIVVs to full cambered position. The AJ torque motor received the PFMO, which fully closed the nozzle. For this condition the nozzle closed at its maximum rate. WFGG decreased to its BUC schedule and the RCVVs changed setting.

At transfer, the augmentor fuel flow was shut off. This rapid decrease of fuel to the augmentor, with the nozzle open, caused a sudden drop in augmentor pressure. This reduced the back pressure on the fan, resulting in the increase in fan speed. The fan speed recovered when the nozzle approached its full closed position.

BUC Transfer

Maximum Power 30,000 Ft, M = 1.2

NASA
DFRF83-525

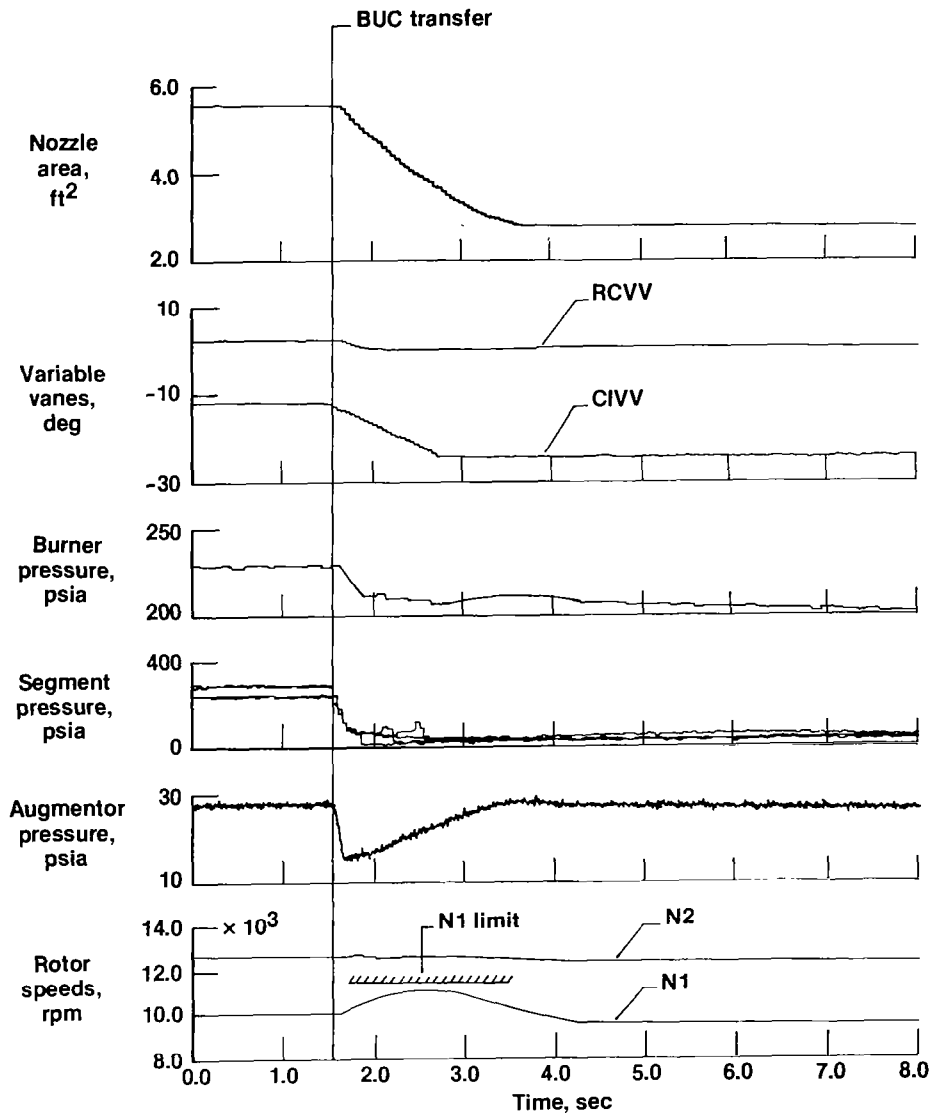

STEADY-STATE PERFORMANCE

The figure below represents a military power level acceleration accomplished in BUC at an altitude of 30,000 ft and a range of Mach from 0.5 to 0.98. Other military power accelerations were performed, but this one provided the best comparison with a military power acceleration under DEEC (primary) control, which is also shown below. Open symbols are the BUC acceleration and solid symbols are the primary acceleration. In addition, a simulation of a BUC and primary military power acceleration obtained from the F100 engine status deck is shown.

In general, the BUC flight performance was lower than the BUC simulation performance except for the corrected fan speed, which was higher than predicted. The primary flight performance agreed well to the primary simulation except for the corrected fan speed, which was higher than predicted, and the fan turbine inlet temperature, which was lower than predicted. For net thrust (FN), the agreement between flight and simulation was good. The thrust was calculated using the real-time thrust method, which will be discussed in Paper 13. The BUC thrust averaged about 1700 lb less than the primary thrust or 70 percent of primary thrust at Mach 0.8. FTIT averaged approximately 230° less for BUC than primary.

BUC Performance Military Power Level Accel 30,000 Ft

NASA
DFRF83-527

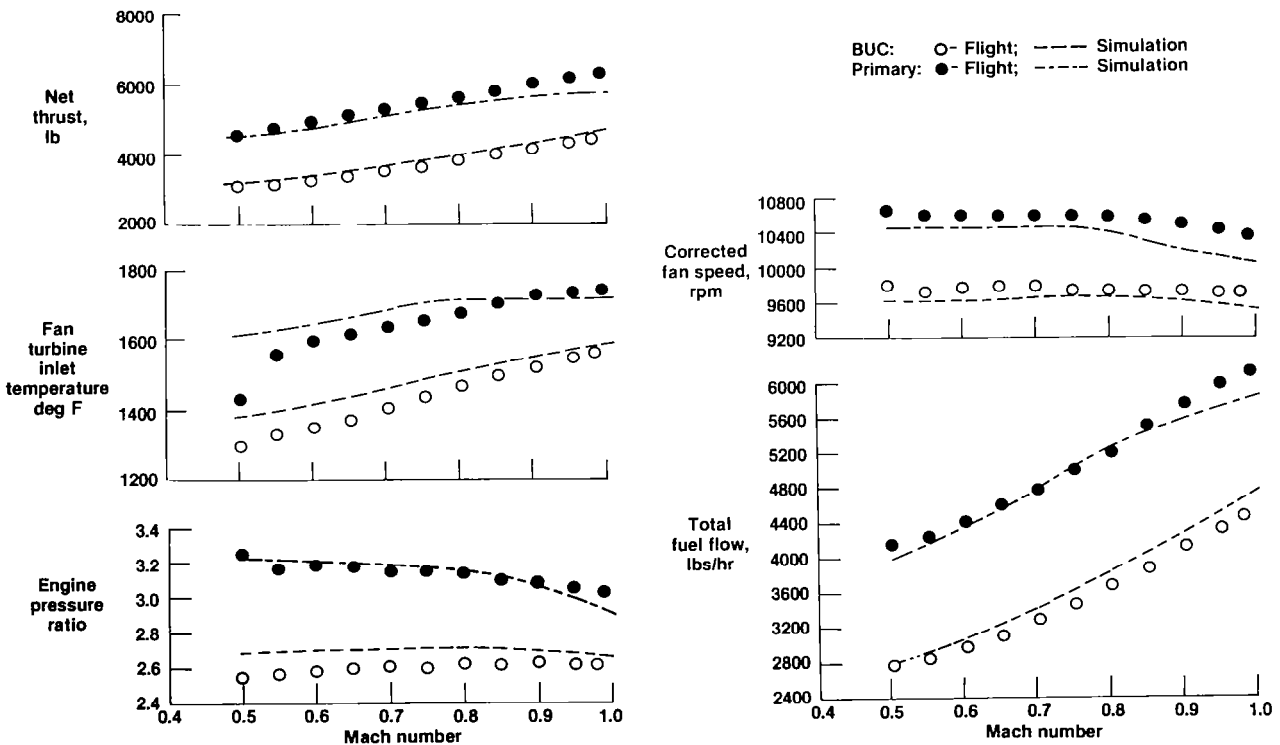

BUC IDLE POWER

At steady-state idle power, the figure below shows trends of percent compressor speeds versus Mach numbers at different altitudes. At 10,000 to 20,000 ft, idle compressor speeds – at all Mach numbers tested – remained at or above 60 percent. At a Mach number of between 0.6 and 0.7 and 35,000 ft, the compressor speed dropped below 60 percent. Idle compressor speeds should be at least 65 percent – below 65 percent is marginal and below 60 percent is undesirable. In this situation the pilot must be aware of the compressor speed to avoid a possible sub-idle compressor stall. Decreasing altitude and gaining airspeed would alleviate this problem. However, this may not be a serious problem because the BUC is not usually operated at high altitude and low airspeed.

BUC Idle Power N2 Steady State

NASA
DFRF83-546

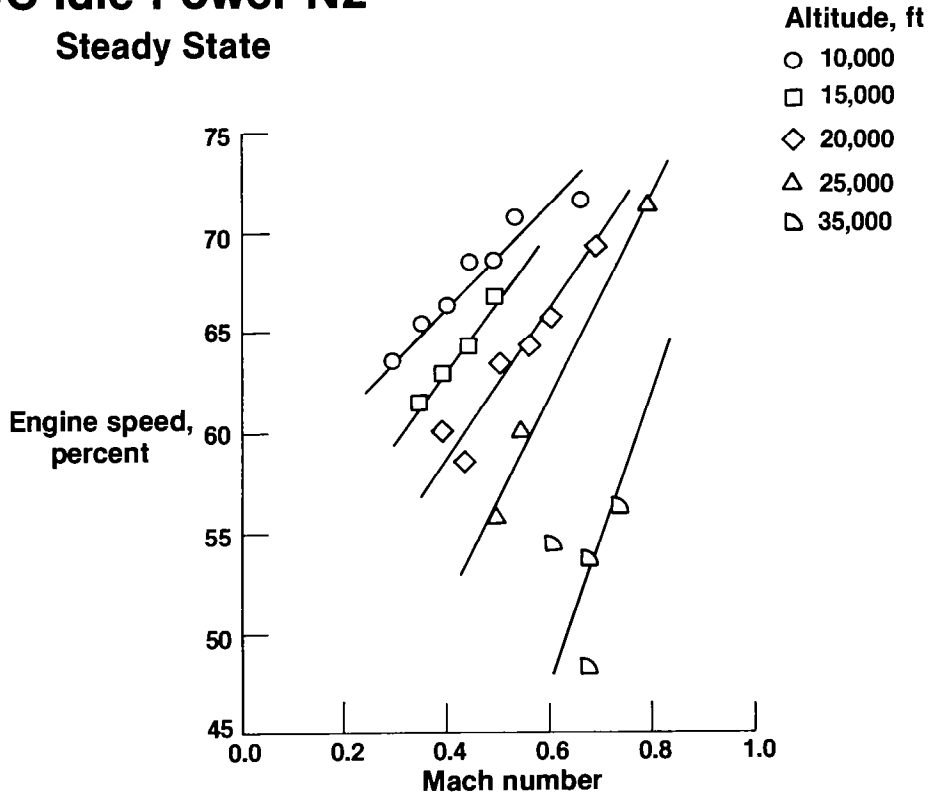

BUC TRANSIENTS

Idle-to-military power BUC transients were performed at various altitudes. The figure below shows the transients that were performed. These transients were snaps and throttle ramps of 3, 5, and 7 sec. The purpose of performing the transients was twofold - to determine the limits where and when compressor stalls occur, and to determine the BUC throttle rate limits for future control designs.

BUC Throttle Ramps Idle-To-Mil Power

NASA
DFRF83-528

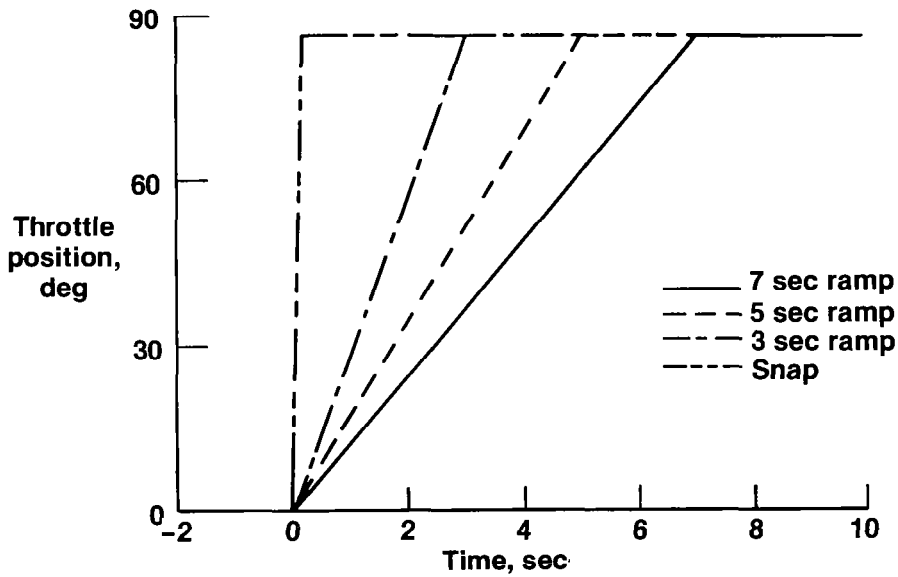

BUC TRANSIENTS RESULTS

Idle-to-military power ramp rates at four altitudes, versus idle speed, are shown in the figure below. It also shows the boundary where compressor stalls occurred for different ramp rates and idle speeds. At idle speeds of above 70 percent N2, all snaps and ramps were successful. Additional transients, not shown in the figure, were successfully completed at compressor speeds greater than 70 percent. At idle speeds of below 60-percent N2, a ramp rate of 7 sec or longer is required to prevent a compressor stall. For a 5-sec ramp N2, idle speed must be maintained above 63 percent.

NASA
DFRF83-547

BUC Throttle Ramp Results Idle-To-Mil Power

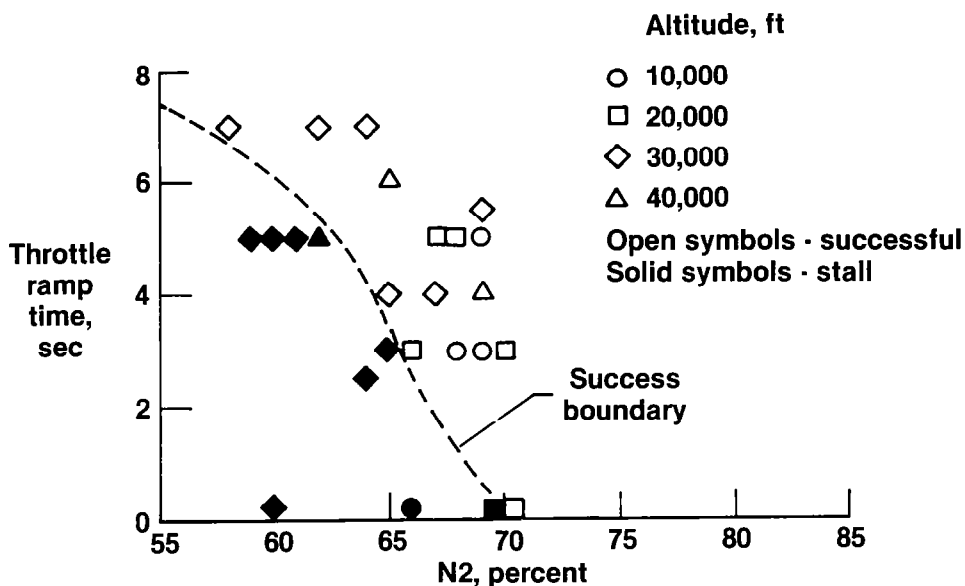

CONCLUDING REMARKS

The performance of the BUC for the DEEC has been evaluated. The following is a summary of this investigation.

- (1) All of the attempted transfers to the BUC were successful.
- (2) BUC intermediate thrust is 70 percent of DEEC intermediate thrust.
- (3) BUC throttle ramp times of 5 sec were successful when N2 was greater than 63 percent.
- (4) At high altitudes and low airspeeds, BUC idle speeds were less than 60-percent N2.
- (5) Pilots like the BUC system.