

## Paper 11

AUGMENTOR TRANSIENT CAPABILITY OF AN F100 ENGINE  
EQUIPPED WITH A DIGITAL ELECTRONIC ENGINE CONTROL

Frank W. Burcham Jr. and G. David Pai  
NASA Ames Research Center  
Dryden Flight Research Facility  
Edwards, California

## SUMMARY

An F100 augmented turbofan engine equipped with a digital electronic engine control (DEEC) system has recently completed a flight evaluation at the NASA Ames Research Center's Dryden Flight Research Facility (DFRF). This engine was equipped with a specially modified augmentor to provide improved steady-state and transient augmentor capability, particularly in the upper left hand corner (ULHC) of the flight envelope where the standard F100 has limited capability. The combination of the DEEC and the modified augmentor was evaluated in sea level and altitude facility tests and then in four different flight phases in an F-15 airplane. This paper describes the augmentor configuration, logic, and test results. An overall description of the DEEC, the test engine, and the test procedures was presented in previous papers.

## AUGMENTOR

The augmentor of the F100 engine equipped with a DEEC system is shown below. It consists of a mixed-flow, fully variable, five-segment augmentor, which exhausts through a variable convergent-divergent nozzle. The augmentor incorporates five segments which start sequentially. Segments 1, 2, and 4 are located in the core stream, while segments 3 and 5 are located in the fan duct stream. The ignitor provides a stream of sparks into the segment 1 flameholder for augmentor ignition. The flameholder consists of radial and circumferential gutters to stabilize and propagate the flame.

### F100 DEEC Augmentor

NASA  
DFRF83-320a

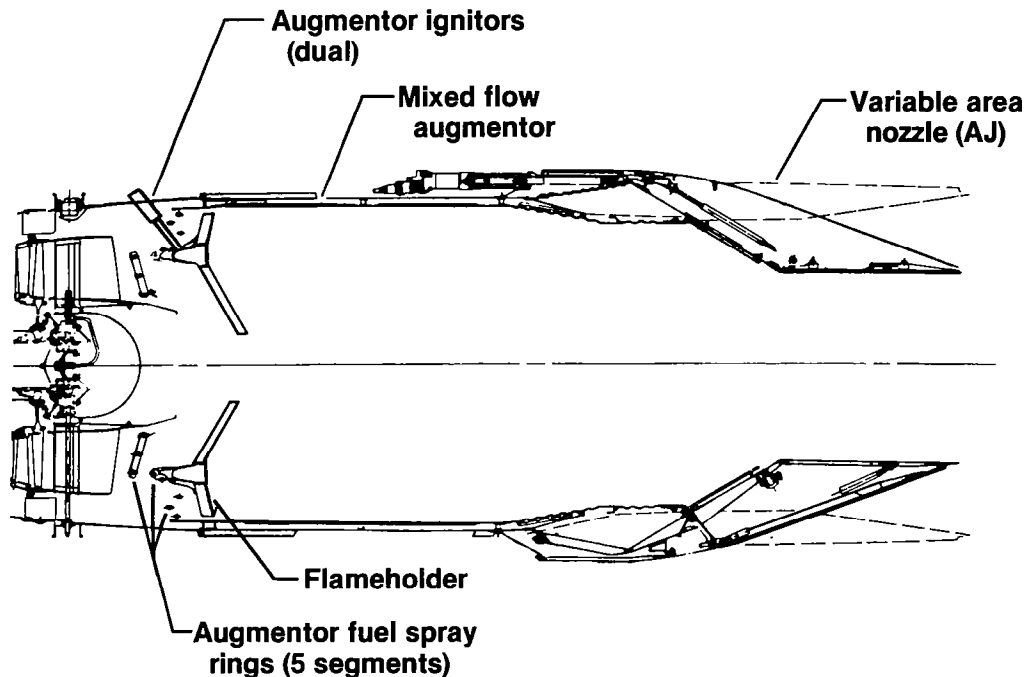

## AUGMENTOR CONTROL HARDWARE

The augmentor control hardware is shown in the figure below. The DEEC controls the segment sequence valve, which handles the fuel distribution. Each of the five segments has a hydromechanical "quickfill" feature, in which a high fuel flow is supplied to rapidly fill the fuel manifold and spray ring. A quickfill sensor which determines when each segment is full by the rise in fuel pressure turns off quickfill to that segment and transfers it to metered fuel flow, scheduled by the DEEC computer. Metered flow to segments 1, 2, and 4 is handled by the core fuel metering valve, while flow to segments 3 and 5 is handled by a separate duct fuel flow metering valve, as shown.

The primary nozzle is modulated by the DEEC computer to maintain the desired engine pressure ratio.

Positions of the augmentor and nozzle actuators are measured by resolvers which are fed back to the DEEC. The torque motor drivers used in the actuators and the resolvers are not redundant for the augmentor.

## DEEC Control System Block Diagram

NASA  
DFRF83-319

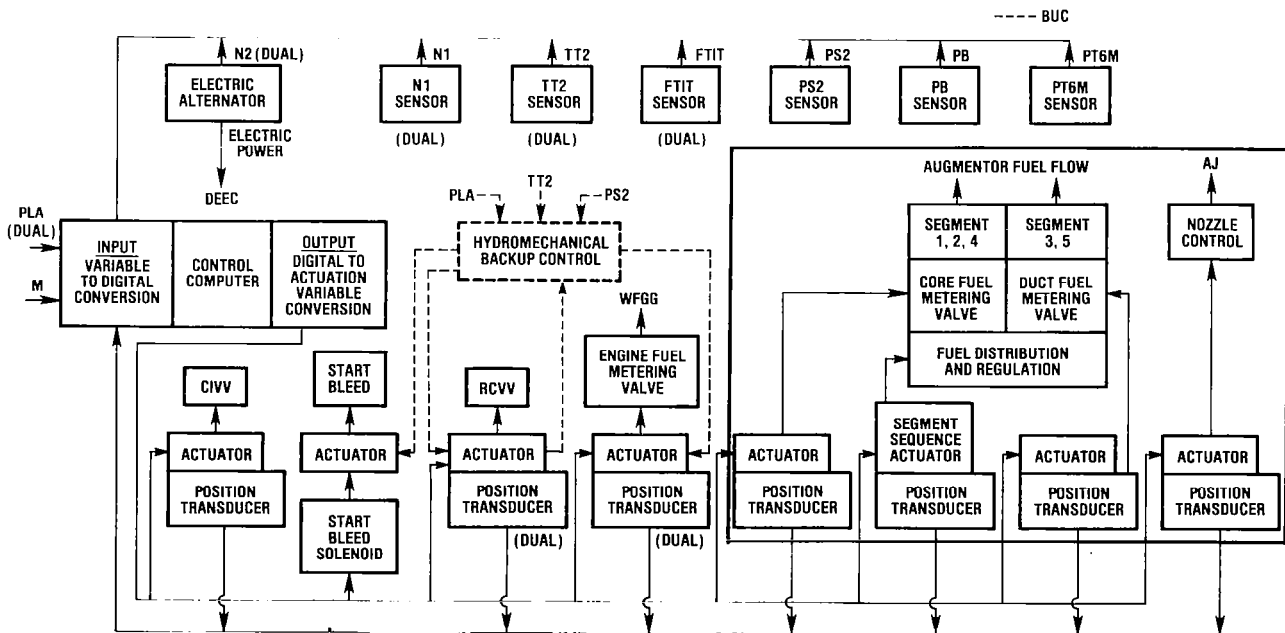

## AUGMENTOR LOGIC

The DEEC logic consists of three basic sections - the fuel flow-scheduling logic, the sequencing logic, and the nozzle control logic.

### Augmentor Fuel Flow Scheduling Logic

The DEEC control system provides improved logic for augmentor control over the standard F100 engine. Fuel-flow-scheduling logic is shown below. The total and core airflow computations are performed as shown. Core and duct stream fuel-air ratios are scheduled as a function of power level angle (PLA) biased by additional variables. Rumble and durability limits are also observed for the duct stream, while ignition and light-off limits are computed for the core stream. The computed duct and core fuel flow commands are sent to the augmentor control metering valves.

## DEEC Fuel Flow Logic

NASA  
DFRF83-322a

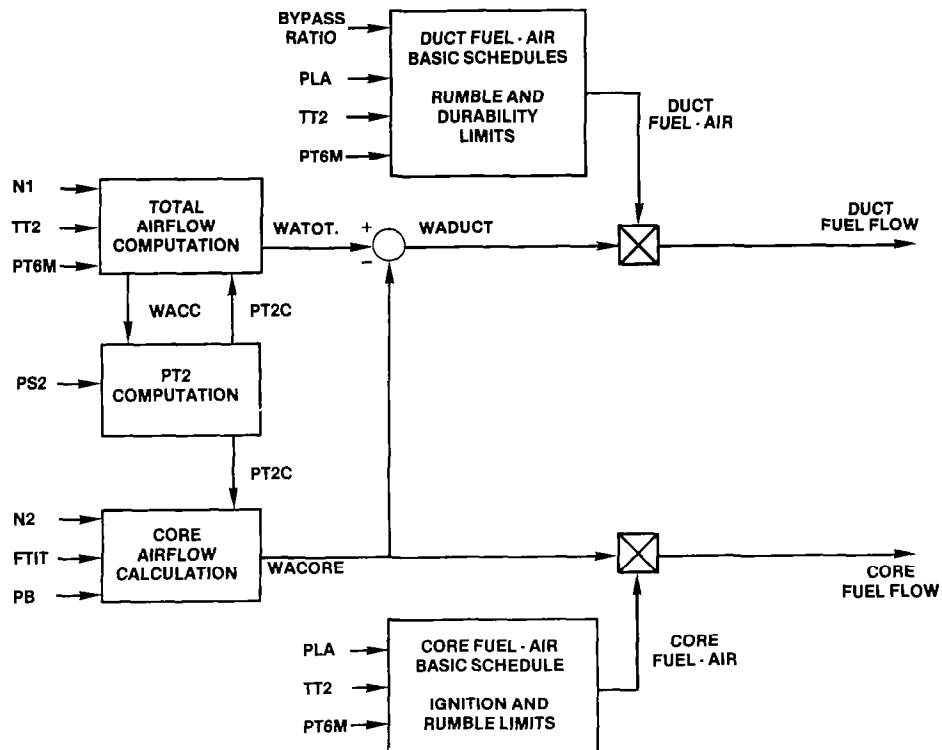

## Augmentor Sequencing Logic

Augmentor sequencing logic is shown below. Prior to augmentor initiation, the augmentor permission requirements must be satisfied. Once these limits are met, the sequencing begins with segment 1 quickfill and augmentor ignition on. The augmentor rate limiting logic is used to slow the sequencing at lower values of calculated fan inlet total pressure (PT2C) where the possibility of stalls and blowouts is greater. The sequencing valve logic is a function of time and accepts signals from the fill sensor and light off detector (LOD), if installed. At lower values of PT2C, there are delays between segments 1 and 2 to allow the flame to stabilize.

### DEEC SEQUENCING LOGIC

NASA  
DFRF83-321

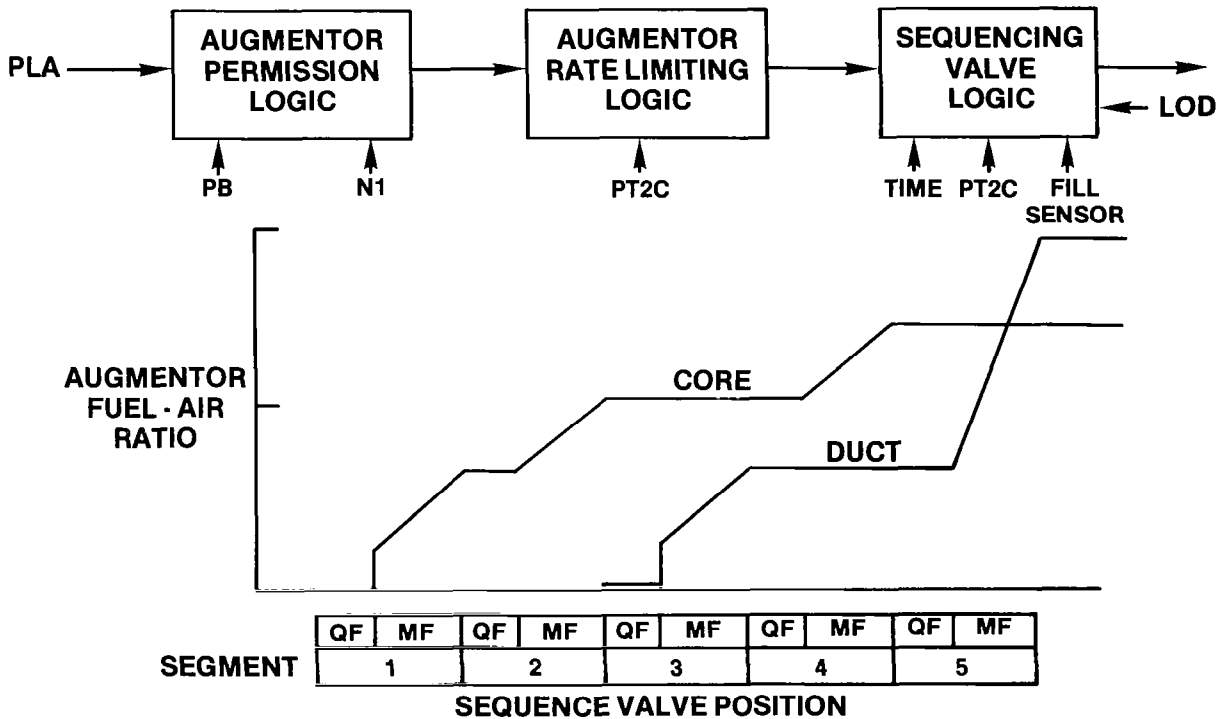

## Nozzle Control

The DEEC system modulates the nozzle during augmentation to maintain the desired engine pressure ratio (EPR). A base jet primary nozzle area (AJ) schedule is generated, which is primarily a function of PLA-AB. The measured EPR, based on fan inlet static pressure (PS2) and turbine discharge total pressure (PT6M), is compared to the requested EPR, based on fan rotor speed (N1) and fan inlet total pressure (PT2). The error in EPR is multiplied by proportional and integral gains and the resulting nozzle trim signal is multiplied by the base AJ command to form the AJ request. The convergent exhaust nozzle control (CENC) drives the nozzle to the requested position. The dashed line encloses the parts of the nozzle control system that were modeled in a nozzle simulation, discussed in Paper 12.

### DEEC EPR Control Mode Nozzle Controls EPR

NASA  
DFRF83-485

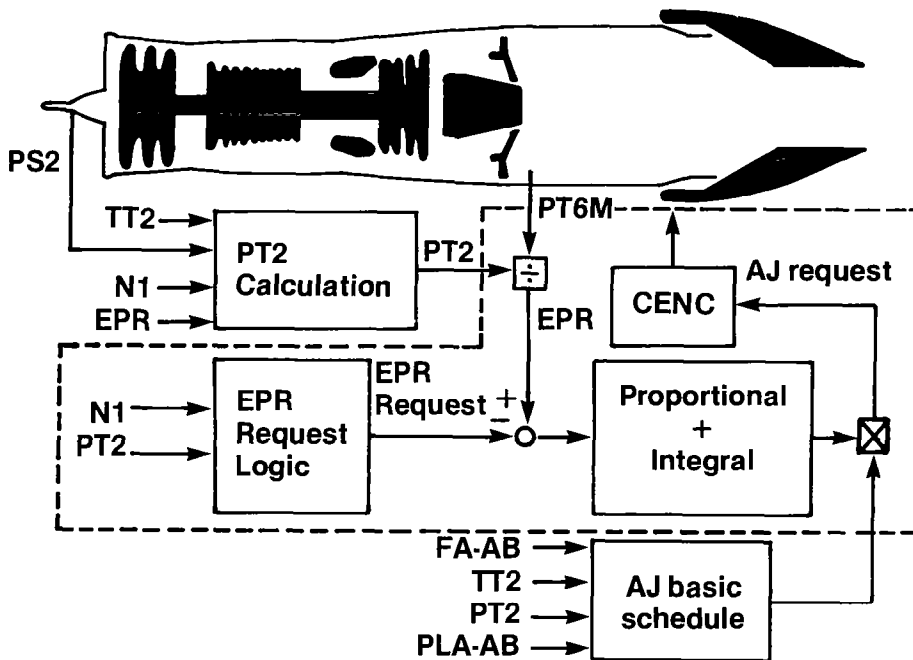

## FLIGHT INSTRUMENTATION AND FUEL SYSTEM

The instrumentation that is pertinent to the augmentor is shown below. The pressure in each of the five augmentor fuel segments is measured with a close-coupled pressure transducer. A high-response pressure transducer is also used to measure augmentor static pressure (PAB). The nozzle area,  $A_j$ , is also measured. The DEEC data includes the augmentor fuel flow rates, position of the segment-sequence valve, light off detector output, and other data.

### DEEC FLIGHT INSTRUMENTATION

NASA  
DFRF82-016b

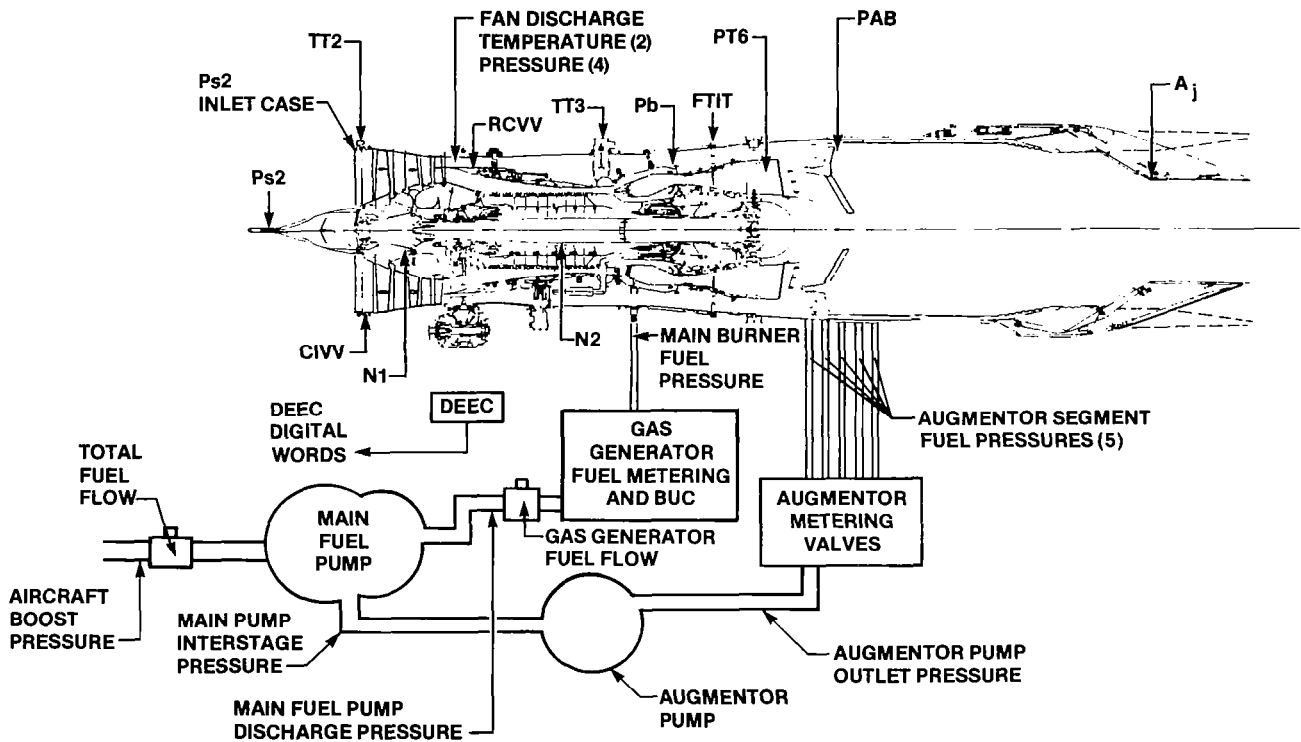

## PHASE 2 AND 3 AUGMENTOR CONFIGURATION

Details of the phase 2 and 3 augmentor configuration are shown below. The spray rings had been specially tailored to provide good fuel distribution at the low segment pressures encountered in the upper left hand corner of the flight envelope. Dual ignitors were installed, one in the normal location, and a second in an area of slightly leaner fuel-air ratios. A ducted core flameholder was used. It scooped a small amount of hot core flow and distributed it into the fan stream gutters to improve the augmentor stability.

In the upper left hand corner of the engine operating envelope, there was a segment 1 limiting feature in the DEEC software. This limited augmentor operation to maximum segment 1 fuel flow even if higher power settings had been requested. There was a switch in the cockpit that permitted the pilot to override the segment 1 limit for special tests. Also shown is the segment 5 redistribution line, above which the segment 5 fuel flow is redistributed into segment 3. This eliminated the very low segment 5 fuel pressures that occur when the segment 5 flows are reduced to prevent rumble in the upper left hand corner.

### DEEC P063 AUGMENTOR CONFIGURATION PHASE 2 & 3

NASA  
DFRF82-950

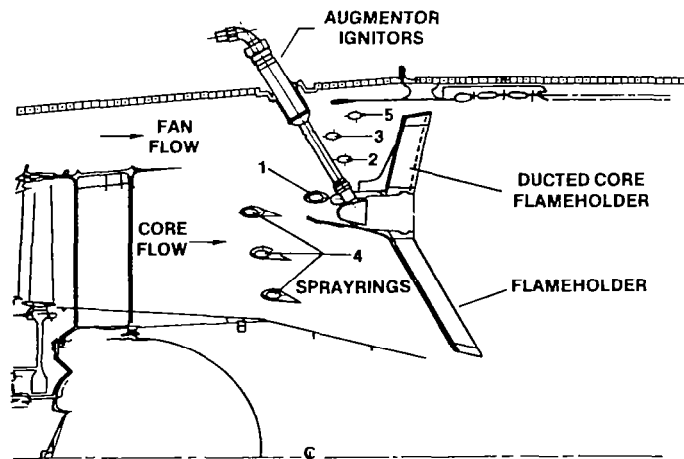

- TAILORED SPRAYRINGS
- DUAL IGNITORS
- DUCTED CORE FLAMEHOLDER
- SEGMENT 1 LIMITING—WITH OVERRIDE
- SEGMENT 5 REDISTRIBUTION

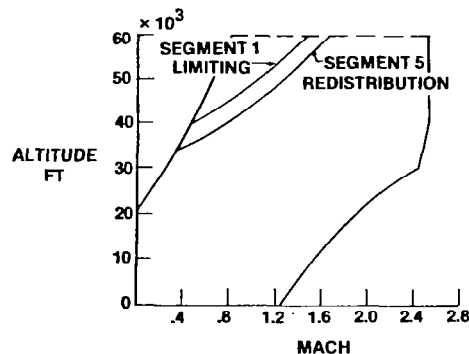



## TYPICAL AUGMENTOR MILITARY-TO-MAXIMUM TRANSIENT

An example of a military-to-maximum power throttle transient is shown below. The parameters shown are time histories of AJ, PAB, and the augmentor segment pressures. At  $t = 3$  sec, the throttle is snapped from military-to-maximum. Segment 1 quickfill begins immediately and the nozzle opens in anticipation of the light. The ignitors are also turned on. The quickfill ends and segment 1 metered flow begins at  $t = 3.4$  sec. The light occurs as indicated by the increase in PAB. A short-hold occurs to allow the flame to stabilize prior to turning on segment 2 quickfill. A quickfill spike occurs as indicated by the rapid rise in segment 2 pressure and the effect is seen in PAB. There is a small quickfill spike in segment 3 but no effect is seen in PAB. At this flight condition, all five segments are used at maximum power. The nozzle modulates to maintain the desired EPR during the sequencing operation, and the transient is completed at  $t = 7$  sec.

## MILITARY-MAXIMUM 175 KNOTS

NASA  
DFRF 82-347

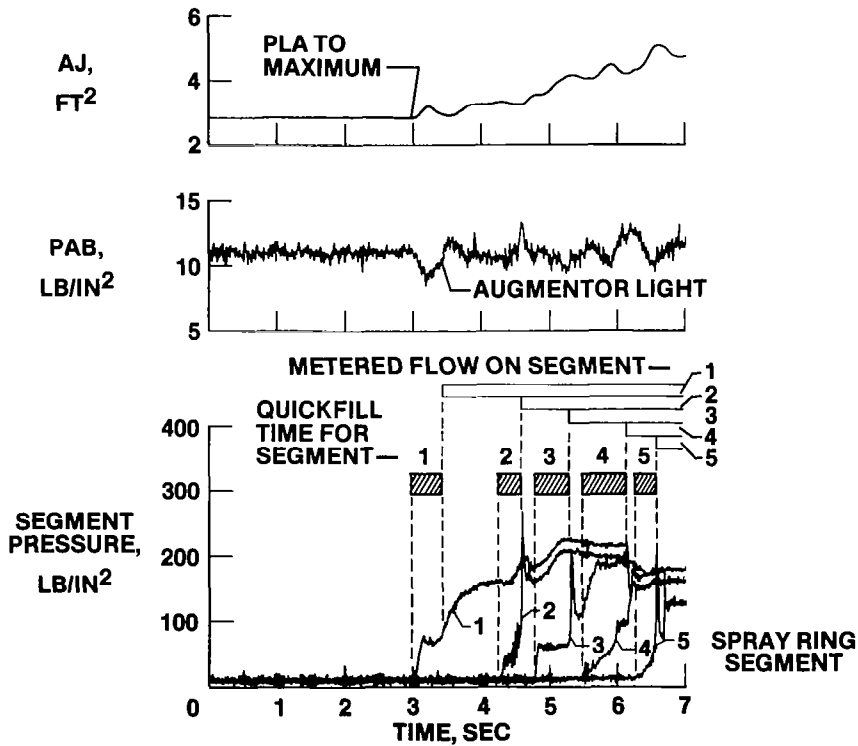

## SUMMARY OF SEGMENT 1 LIMITED THROTTLE TRANSIENTS

The DEEC phase 2 military-to-maximum and idle-to-maximum throttle transients, with segment 1 limiting, are summarized below. All transients were successful at altitudes to 50,000 ft and airspeeds as low as 150 knots.

## SEGMENT 1 LIMITING SUMMARY

NASA  
DFRF82-367

- INTERMEDIATE-MAXIMUM
- IDLE-MAXIMUM
- OPEN SYMBOLS DENOTE SUCCESSFUL TESTS
- SOLID SYMBOLS DENOTE UNSUCCESSFUL TESTS

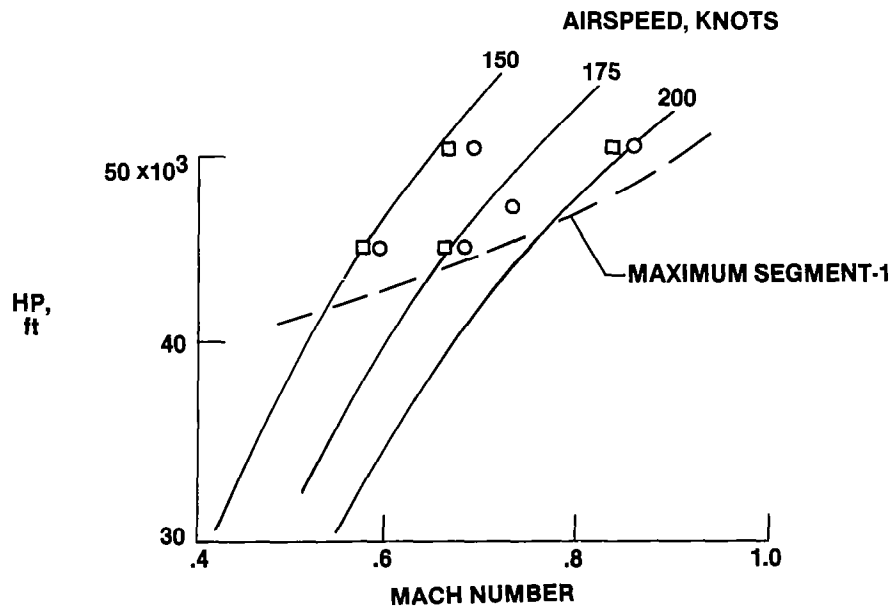

## SUMMARY OF PHASE 2 MILITARY-TO-MAXIMUM TRANSIENTS

The phase 2 military-to-maximum throttle transients are summarized below. The segment 1 override switch in the cockpit was used to obtain full augmentor operation above the segment 1 limiting line. Stalls and blowouts occurred at airspeeds of 175 knots or less at altitudes of 40,000 ft and above. The stalls were due to quick-fill spikes and nozzle instabilities, while the blowouts were caused by nozzle instabilities and sequencing problems. Additional information on these problems will be discussed in later sections.

### MILITARY TO MAXIMUM TRANSIENT PHASE 2, MARCH 1982

NASA  
DFRF82-1008

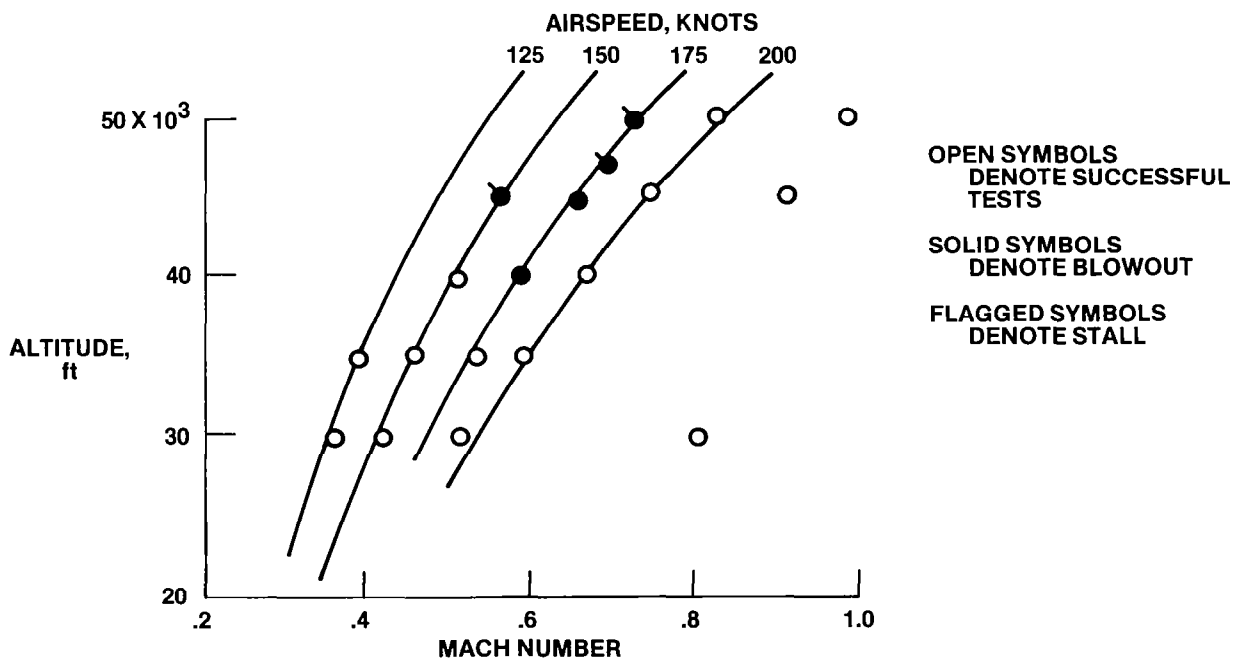

## SUMMARY OF PHASE 2 IDLE-TO-MAXIMUM TRANSIENTS

The phase 2 idle-to-maximum transients are shown below. The segment 1 override switch was used to get full augmentor operation above the segment 1 limiting line. These transients were successful at 30,000 ft and airspeeds above 200 knots. Stalls, blowouts, and two nonrecoverable stalls (stagnations) occurred, as shown. These unsuccessful transients were caused by nozzle instabilities, quickfill spikes, rumble, and sequencing problems.

### IDLE TO MAXIMUM TRANSIENTS PHASE 2, MARCH 1982

NASA  
DFRF82-1009

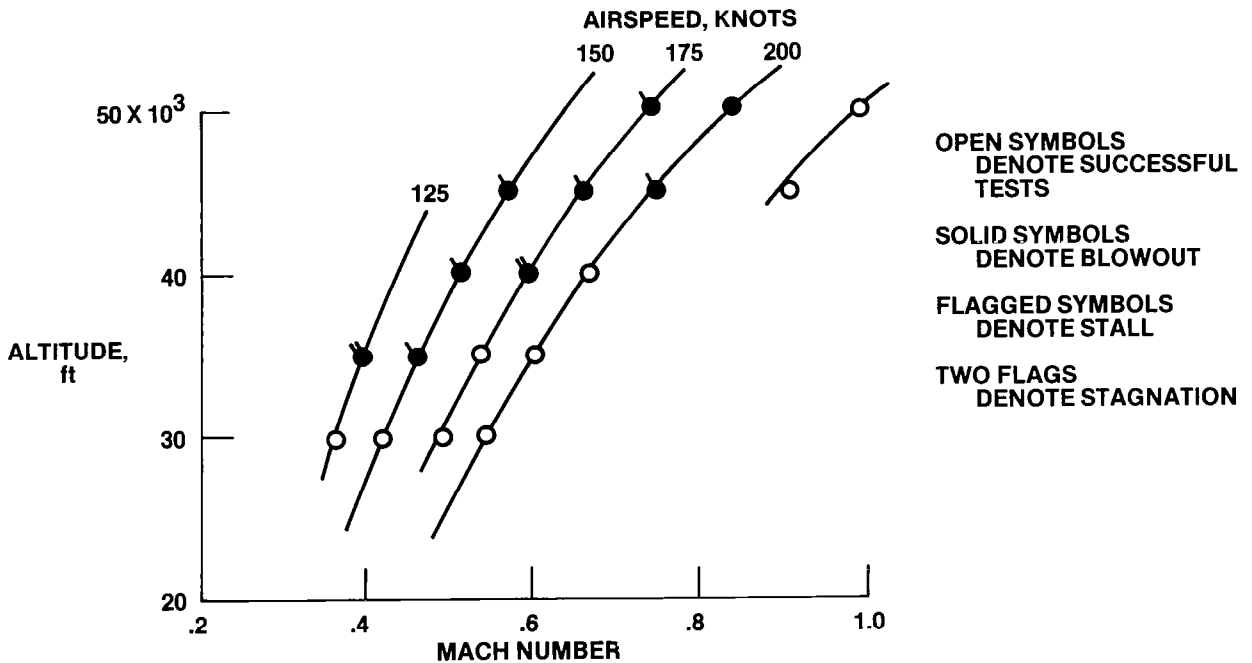

## QUICKFILL STALL

An example of a stall caused by a quickfill spike is shown below. The segment 1 light is normal, but during the segment 2 quickfill, the pressure rises to 300 lb/in<sup>2</sup> causing excess fuel to enter the augmentor. When this fuel burns, the pressure pulse propagates upstream to the fan, and increases its pressure ratio above the stall line, resulting in a stall. Quickfill stalls occurred primarily in the upper left hand corner and mostly during segment 2 quickfill, although occasional segment 3 quickfill stalls were noted, and one segment 1 quickfill stall occurred in 994 augmentor lights.

### QUICKFILL STALL 150 KNOTS

NASA  
DFRF 82-348

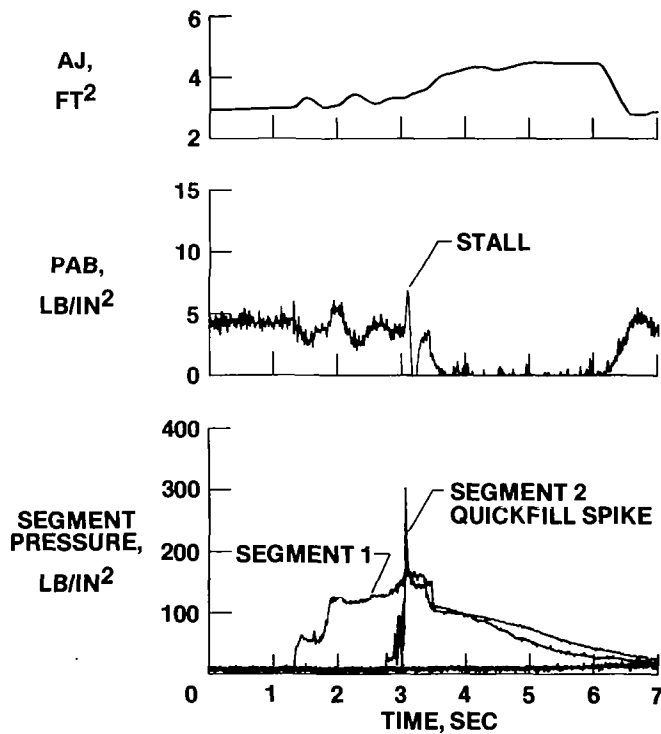

## AUGMENTOR RUMBLE

Rumble is a moderate frequency (50 Hz to 60 Hz) oscillation caused by acoustic-combustion coupling phenomena. It generally results when a locally overrich fuel-air ratio occurs somewhere in the augmentor. The DEEC logic incorporates rumble protection features which reduce the fuel-air ratio in the upper left hand corner of the operating envelope. The logic was developed based on previous experience and on altitude tests of DEEC engines at Arnold Engineering Development Center (AEDC).

Shown below is a time history of an idle-to-maximum throttle transient at 175 knots and 45,000 ft. An augmentor blowout occurred at  $t = 7.2$  sec. A detailed examination of the PAB trace at a sampling rate of 200/sec revealed that just prior to the blowout, a discrete 60 Hz oscillation had developed with an amplitude of  $2 \text{ lb/in}^2$  peak to peak. This development of rumble coincides with the segment 4 fuel flow reaching its full scheduled flow. Rumble was detected in at least eight idle-to-maximum transients in the upper left hand corner. In each case this occurred just as segment 4 reached full flow. In a few cases, a few cycles of rumble were detected but blowout did not occur and stable operation was established.

### RUMBLE BLOWOUT

NASA  
DFRF 82-349

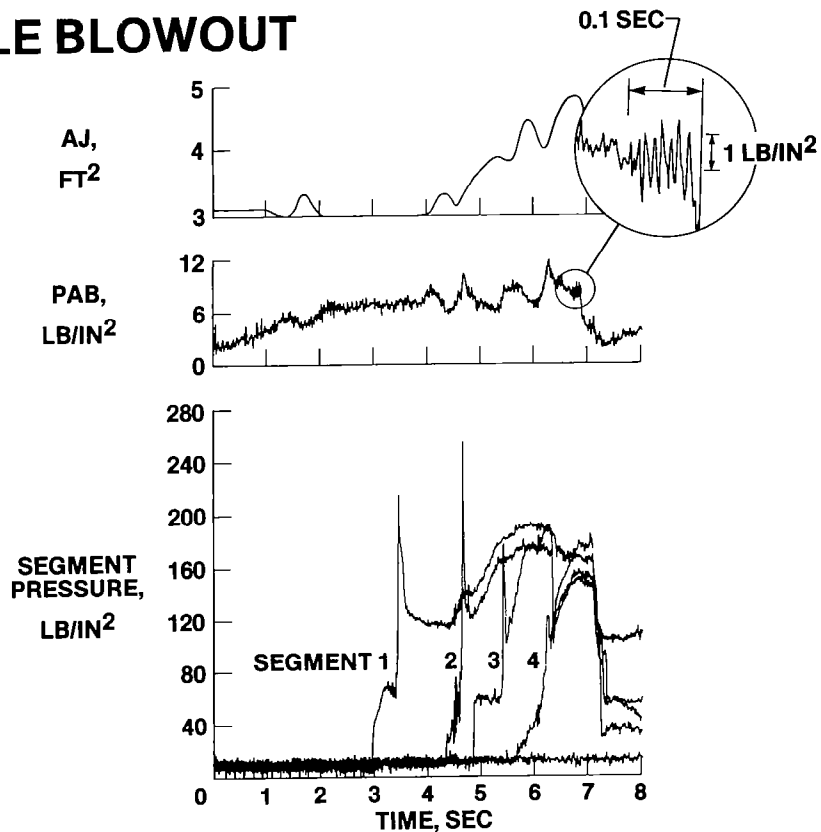

## SEGMENT TRANSFER BLOWOUTS

Augmentor blowouts sometimes occurred during transfers from one segment to the next. A military-to-maximum snap at an altitude of 45,000 ft and 150 knots is shown below. At  $t = 6$  sec, segment 4 quickfill has been completed. When segment 4 metered flow begins, the pressure in segments 1 and 2 drops, since these segments are all supplied by the core metering valve. The increase in PAB indicates that the core fuel flow has increased significantly during the transfer. The nozzle opens rapidly to lower the EPR and the rapid drop in pressure causes a blowout. Many of the blowouts in phase 2 occurred during this segment 3 to 4 transfer. Some stalls also occurred when the PAB increase was sufficient to stall the fan.

NASA  
DFRF83-395

### DEEC Augmentor Blowout - Phase 2 Following Segment 3 To 4 Transfer 45,000 Ft, 150 Knots

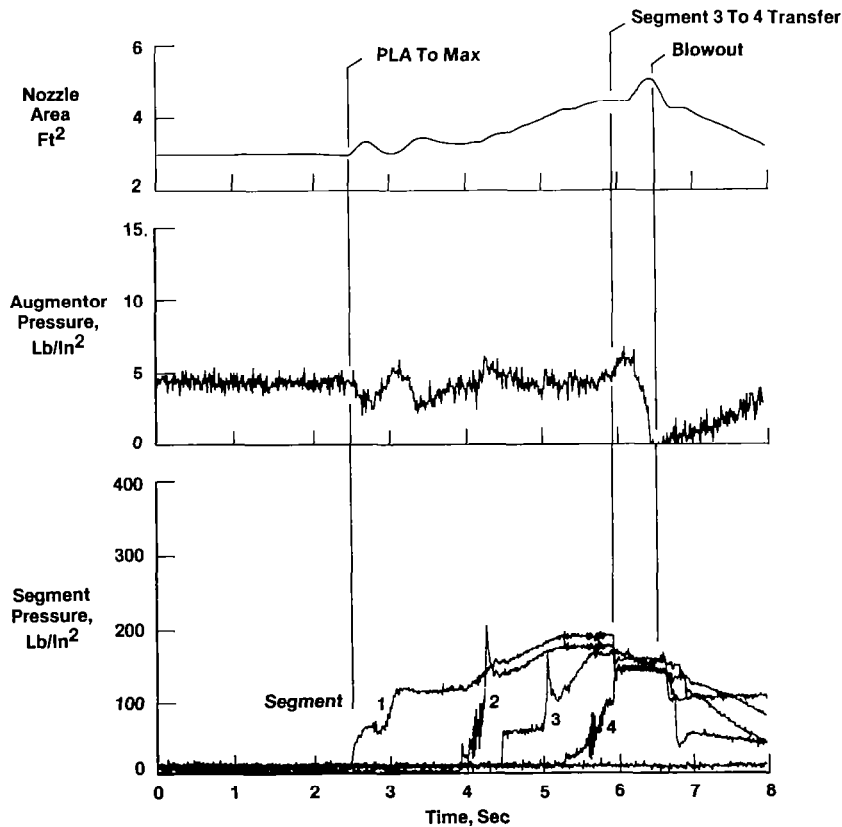

## NOZZLE INSTABILITY

In the upper left hand corner of the operating envelope, the nozzle experienced an instability. As shown below, following a military-to-maximum snap, the nozzle began a limit cycle with PAB oscillations. On each cycle, positive peaks indicate when the engine approached a stall condition and negative valleys represent when the engine approached a blowout condition. This instability caused many problems during augmentor operation and is discussed in more detail in Paper 12.

### DEEC Nozzle Instability - Phase 2

NASA  
DFRF83-393

Mil To Max With Override  
45,000 Ft, 200 Knots

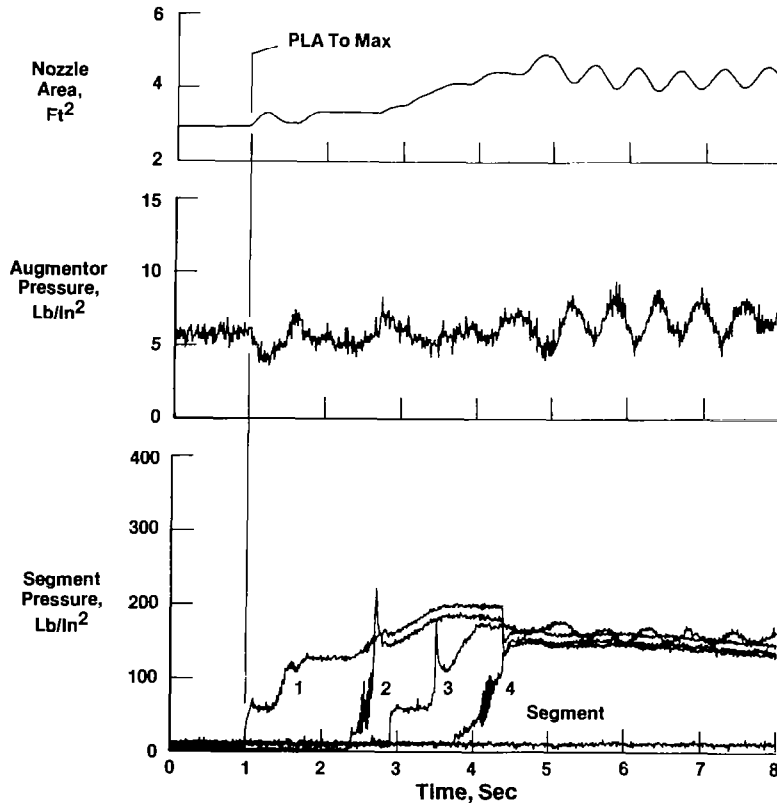



## PHASE 2 RESULTS SUMMARY

At the end of phase 2 flight testing, the augmentor performance was strongly influenced by various factors. These were: blowouts due to rumble, stalls due to quickfill spikes, stalls and blowouts due to segment transfers, and stalls and blowouts due to nozzle instability. An additional cause of blowouts was the early augmentor permission that allowed augmentor lighting on idle-to-maximum snaps at fan speeds of 80 percent.

### **DEEC Status-End of Phase 2**

**NASA**  
DFRF83-484

- **Blowouts due to rumble**
- **Stalls due to quickfill spikes**
- **Stalls and blowouts during segment transfers**
- **Stalls and blowouts due to nozzle instability**
- **Blowouts due to early augmentor permission**

## PHASE 3 OBJECTIVES

For phase 3, there were several changes to the augmentor logic and hardware to try to improve the augmentor performance. Logic changes were incorporated to eliminate rumble and augmentor instability. A quickfill sensor change was made to incorporate a sensor with better damping characteristics, called the damped quickfill sensor. In addition, it was desirable to replace the ducted core flameholder with the F100 production flameholder. In the phase 3 flight evaluation, these changes were made systematically to allow the individual effects to be determined.

## DEEC PHASE 3 OBJECTIVES

**NASA**  
DFRF82-946

- **EVALUATE EFFECTS OF SOFTWARE AND HARDWARE CHANGES ON AUGMENTOR TRANSIENT PERFORMANCE**
- **EVALUATE SOFTWARE FIX FOR AUGMENTOR INSTABILITY**

## PHASE 3 MILITARY-TO-MAXIMUM TRANSIENT RESULTS

The first flights in phase 3 were made with the same hardware as phase 2, but with the new logic to eliminate rumble and nozzle instability. The results are shown below. In phase 3A, the improved logic successful transient line was moved up by as much as 5000 ft. No augmentor instability or rumble was noted. The addition of the damped quickfill sensor in phase 3B had no discernable effect on military-to-maximum transients. In phase 3C, the production flameholder seemed to be slightly better at Mach 0.6 at 45,000 ft. Other than blowouts at 50,000 ft, the augmentor performance was quite good.

NASA  
DFRF82-366c

### Military-To-Maximum Transient Phase 3, October 1982

Open symbols denote successful tests  
Solid symbols denote blowout

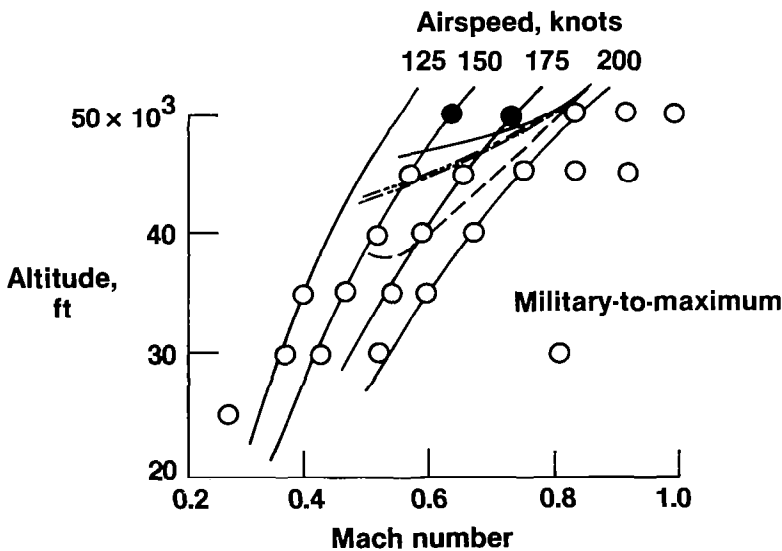

Success boundary

	Phase	Logic	Q/F sensor	Flame-holder
---	2	2.3.7A	Undamped	Ducted core
- - -	3a	2.3.7B	↓	↓
---	3b	↓	Damped	↓
—	3c	↓	↓	Prod.

## PHASE 3 IDLE-TO-MAXIMUM TRANSIENTS RESULTS

The same changes for phase 3 were also evaluated for idle-to-maximum transients. The logic changes of phase 3A produced slight improvement, while the change to the damped quickfill sensor resulted in bigger improvements. The production flameholder had no apparent effect. Again, no rumble or nozzle instability was noted. The total altitude improvement was as much as 5000 ft. Due to the small number (eight) of flights in phase 3 and the statistical nature of augmentor transient success, these individual improvements should be viewed as indicating trends rather than absolute results. One problem that still remained on idle-to-maximum transients was early augmentor permission. The logic was permitting the augmentor to begin sequencing at fan speeds as low as 80 percent. This resulted in the lighting and sequencing taking place at considerably lower pressures and temperatures than on military-to-maximum snaps.

NASA  
DFRF82-346c

### Idle-To-Maximum Transients Phase 3, October 1982

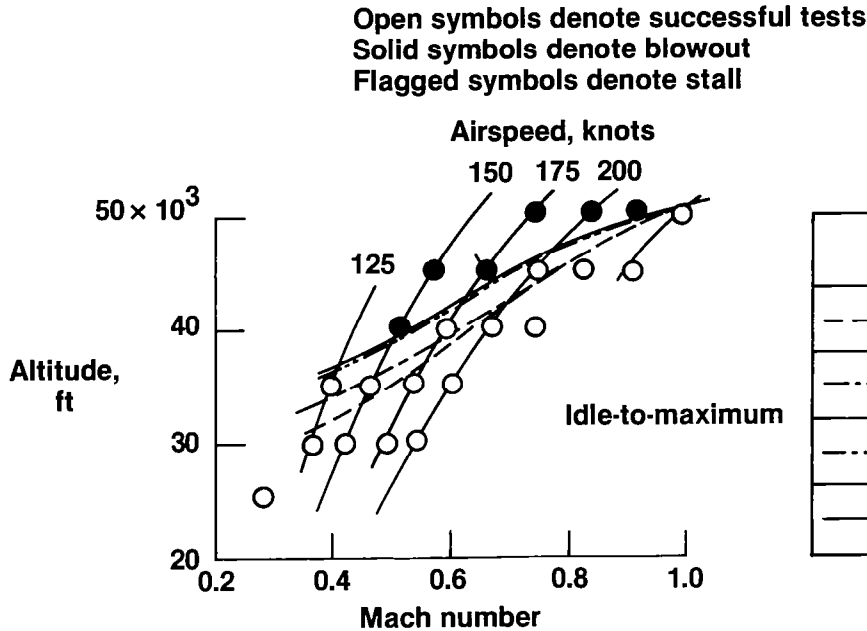

Success boundary

	Phase	Logic	Q/F sensor	Flameholder
---	2	2.3.7A	Undamped	Ducted core
-.-.-	3a	2.3.7B	↓	↓
----	3b	↓	Damped	↓
—	3c	↓	↓	Prod.

## PHASE 4 OBJECTIVES AND LOGIC CHANGES

For the phase 4 flight evaluation, the augmentor light off detector (LOD) was available. Logic changes were made to incorporate the LOD and to make further improvements based on previous results. The availability of the LOD made it practical to incorporate a fast acceleration capability in which, on idle-to-maximum throttle snaps, the augmentor lighting sequence took place during the gas generator spoolup. Also, because of the LOD, logic was installed to automatically recycle the DEEC power level angle (PLA) in case of augmentor blowout.

## DEEC PHASE 4

**NASA**  
DFRF82-955

- **AUGMENTOR IMPROVEMENTS**  
**LIGHT OFF DETECTOR**  
**LOGIC CHANGES**
- **FASTER THROTTLE TRANSIENTS**  
**REDUCE IDLE TO MAX TIME FROM 7 TO 3.5 SEC**  
**AUTOMATIC RELIGHT FOR AUGMENTOR BLOWOUTS**
- **BACKUP CONTROL IMPROVEMENTS**

## PHASE 4 AUGMENTOR CONFIGURATION

The augmentor configuration for phase 4 is shown below. The LOD, an ultraviolet sensor, was installed so the flame just downstream of the flameholder could be viewed. It provided an output proportional to flame intensity to the DEEC. Also incorporated in phase 4 was the F100 production flameholder and a recalibrated segment 1 spray ring. The segment 1 limiting line and the segment 5 redistribution line were unchanged from phase 3. In the region shown, augmentor permission was available immediately on idle-to-maximum snaps. At lower airspeeds, the augmentor permission required higher fan speeds, and in the upper left hand corner, the fan speed for augmentor permission was raised to 98 percent of the intermediate fan speed request.

### DEEC P063 AUGMENTOR CONFIGURATION PHASE 4

NASA  
DFRF82-951

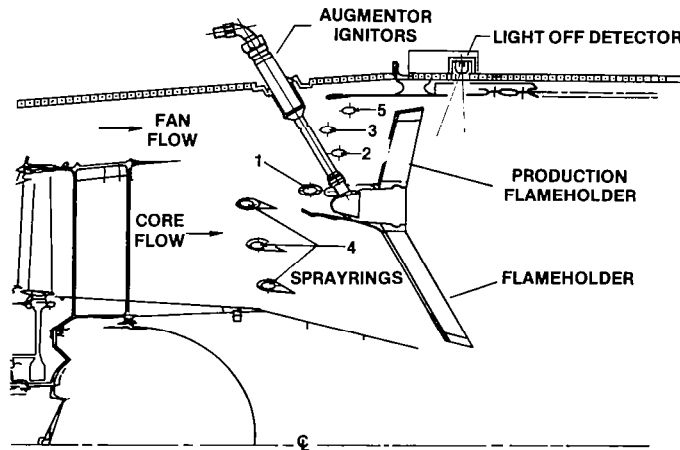

- LIGHT OFF DETECTOR
- TAILORED SPRAYRINGS
- DUAL IGNITORS
- PRODUCTION FLAMEHOLDER
- SEGMENT 1 LIMITING
- SEGMENT 5 REDISTRIBUTION

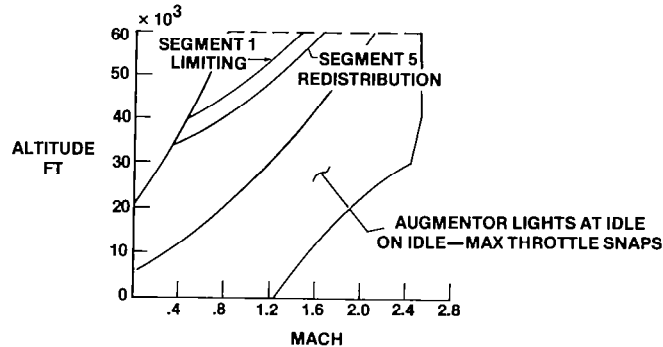

## PHASE 4 SUMMARY OF MILITARY-TO-MAXIMUM TRANSIENTS

The DEEC phase 4 military-to-maximum transient summary is shown below. A large improvement over phase 3 is shown with successful transients at all conditions at 50,000 ft and below, even with the override to allow full augmentation. At altitudes above 50,000 ft one stall-stagnation occurred, but successful transients were completed up to 58,000 ft. This provided full augmentation capability almost to the edge of the F-15 flight envelope, as shown. Some PLA recycles were required to complete the transients at 50,000 ft and above.

NASA  
DFRF83-054

### DEEC PHASE 4 MILITARY TO MAXIMUM TRANSIENTS

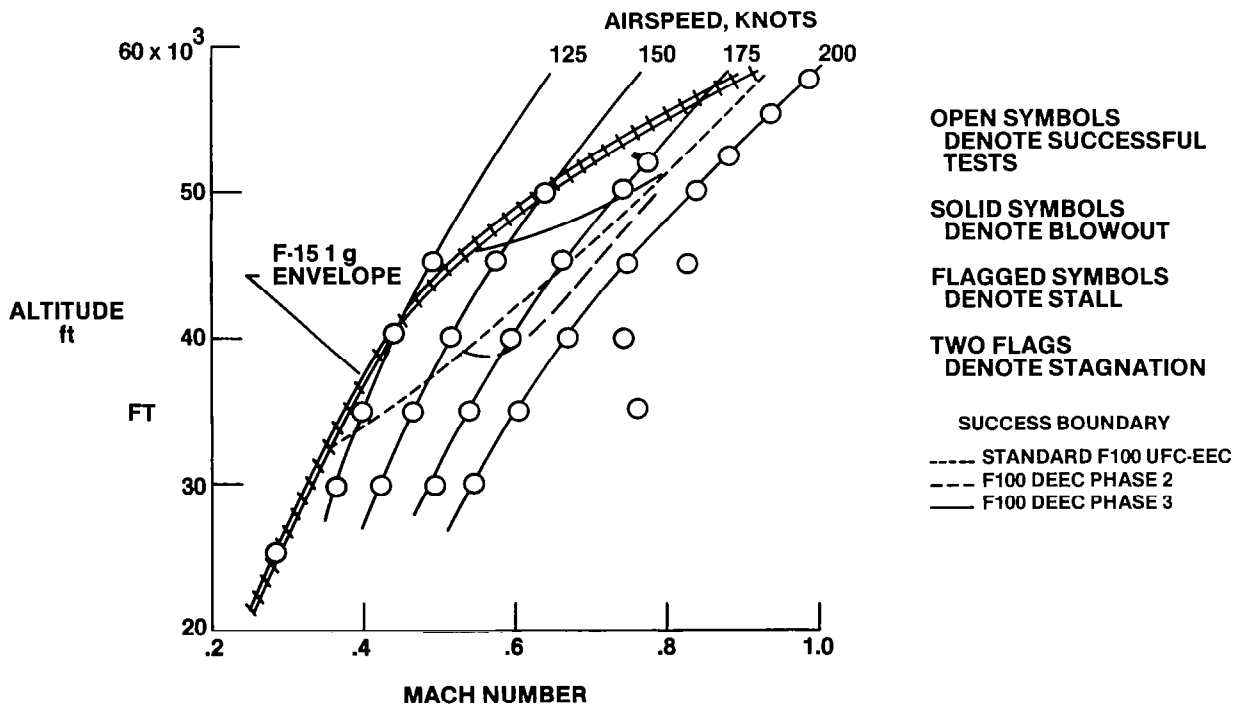

## PHASE 4 MILITARY-TO-MAXIMUM TRANSIENT

An example of a military-to-maximum snap at 45,000 ft and 125 knots is shown below to illustrate the performance of the LOD. Following the snap to maximum power segment 1 fuel flow is turned on and the light occurs almost immediately, as indicated by the rise in LOD counts. The light is also seen on PAB. The logic requires a 1.25 sec hold in segment 1 to allow the flame to stabilize, and then allows the sequencing to continue. Once segment 3 is lit, the LOD counts drop off as the flame pattern shifts. At maximum power, a slight nozzle oscillation causes the flame pattern to shift back and forth, as seen in the LOD output.

### DEEC Phase 4 Mil-max 45,000 ft, 125 Knots

NASA  
DFRF83-481

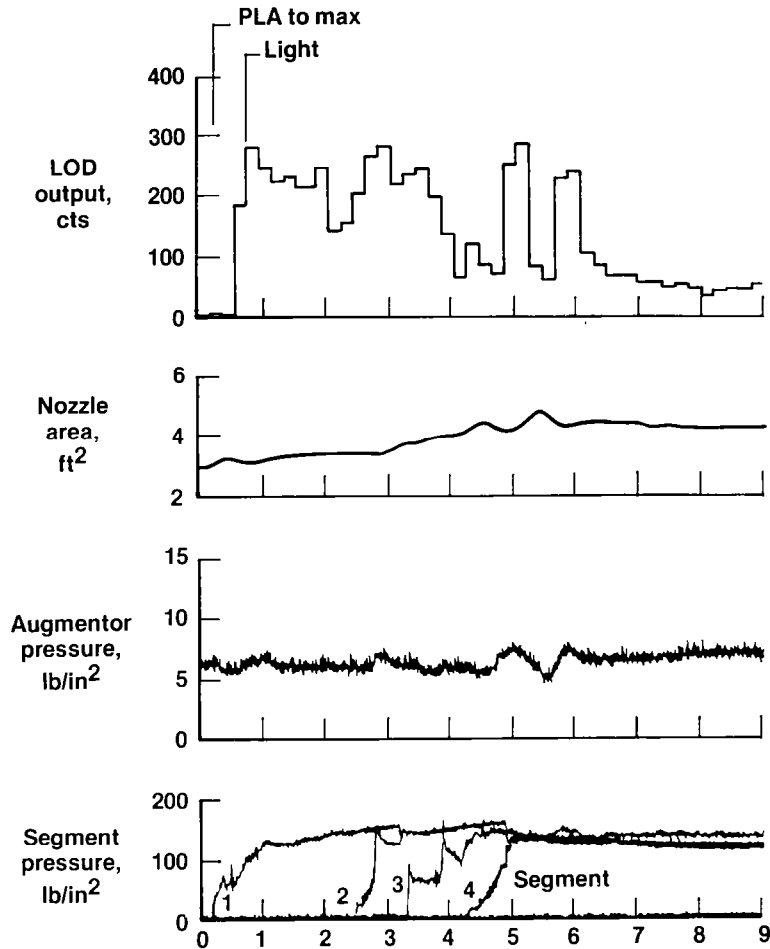



## PLA RECYCLE

An example of the LOD performance and logic action following a blowout is shown below at 50,000 ft and 175 knots. Following the snap to maximum, segment 1 quickfill begins and the light is detected. During the segment 1 hold, the LOD counts drop to less than 40, indicating a weak flame. Segment 2 flow increases the LOD output only briefly, and by the segment 4 turn-on, the LOD output falls to 0. Augmentor fuel is shut off and the DEEC PLA is cycled back to intermediate to begin a recycle. The LOD goes through a self-test cycle, as shown, to verify proper operation prior to the attempted relight. Note the much higher LOD counts in segment 1 on the recycle. The rest of the light is normal. Up to three PLA recycles are allowed by the DEEC logic; however, no more than two were ever required in phase 4 testing.

### DEEC PLA Recycle Mil-Max 50,000 ft, 175Knots

NASA  
DFRFB3-483a

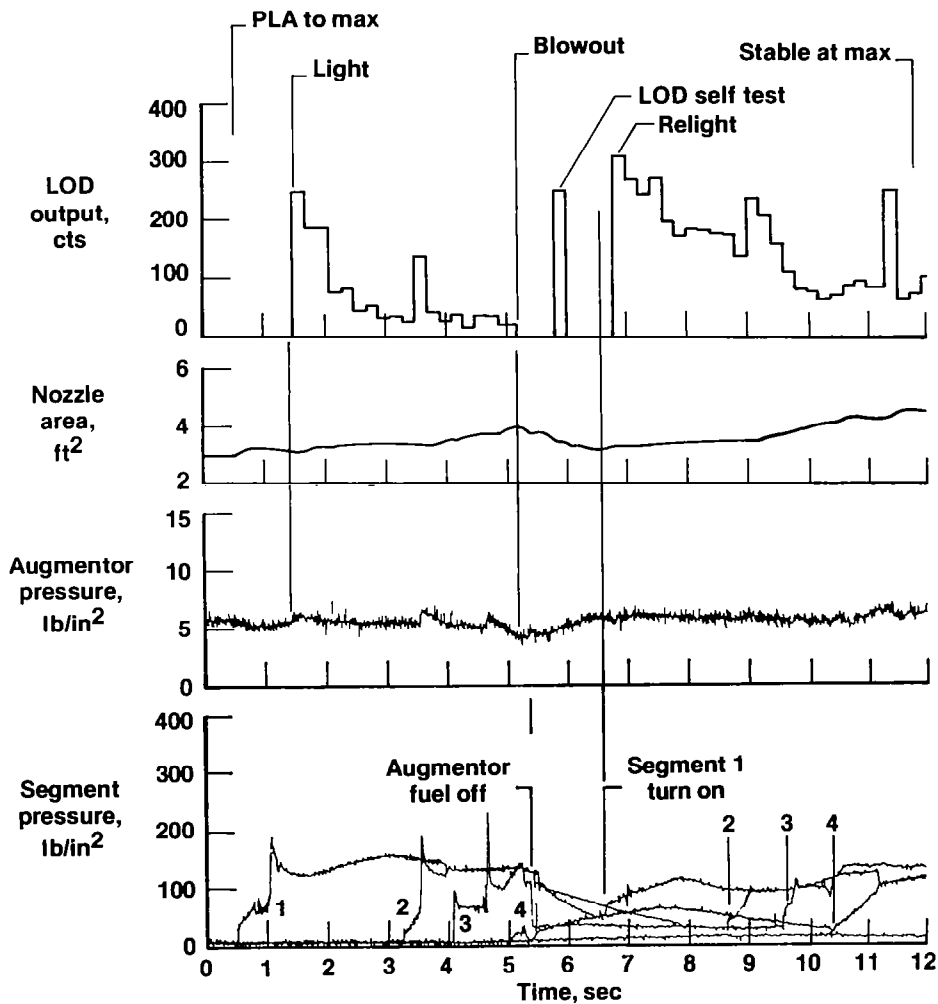

## PHASE 4 IDLE-TO-MAXIMUM TRANSIENT

An idle-to-maximum snap transient at 50,000 ft and 150 knots, with the override switch on, is shown below. The PLA was advanced to maximum at  $t = 1.5$  sec. Augmentor permission was delayed at this flight condition until the fan speed reached 98 percent of its request, which, in this case, took 5.5 sec. Augmentor quickfill began at  $t = 7$  sec, and the light was detected at  $t = 8$  sec. After the 1.25 sec segment 1 hold, the logic released the sequencing and maximum power was achieved at  $t = 12$  sec. The segment 3 to 4 transfer caused an overfill that increased PAB, but no stall occurred. There was some nozzle oscillation which damped out quickly. The effect of the delayed augmentor permission is to make the idle-to-maximum transient very similar to a military-to-maximum transient, with hot core flow and higher pressure levels in the augmentor prior to augmentor sequencing.

### DEEC Phase 4 Idle-To-Max Snap 50,000 Ft, 150 Knots

NASA  
DFR83-480

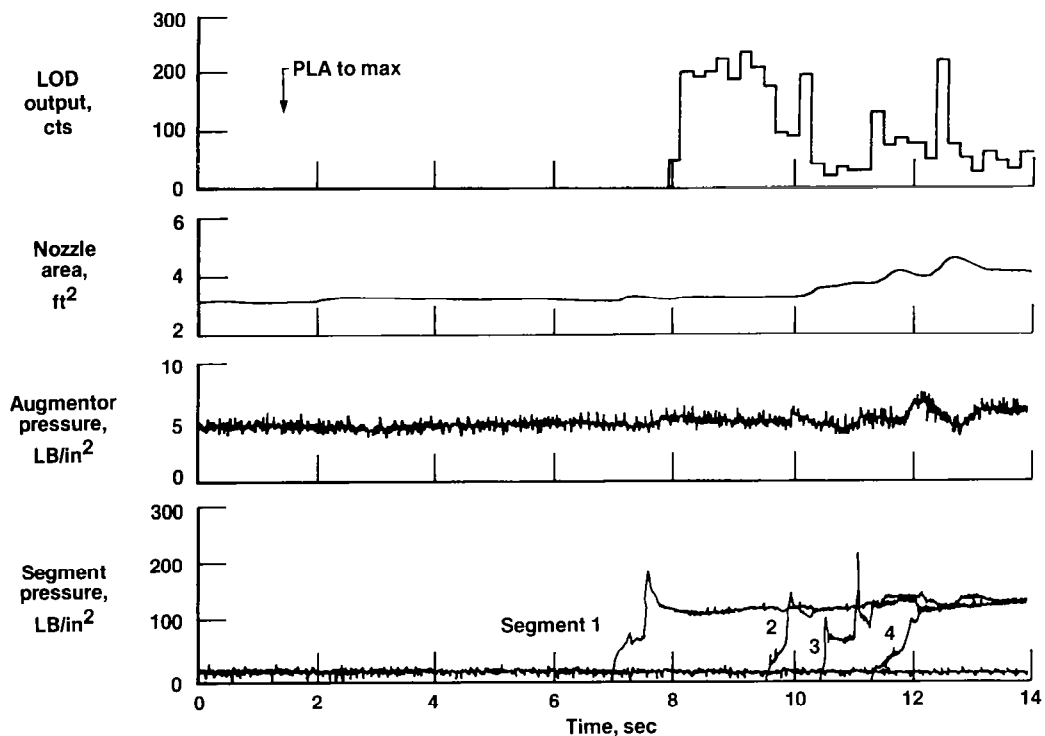

## SUMMARY OF PHASE 4 IDLE-TO-MAXIMUM TRANSIENTS

A summary of the DEEC phase 4 idle-to-maximum power transients is shown below. Most of these transient tests were made with the augmentor override switch, since they would otherwise have been limited to segment 1. All transients were successful, including tests at altitudes up to 58,000 ft and airspeeds of 125 knots at 45,000 ft. Some PLA recycles were required at the higher altitudes. As is seen, the test conditions extended to the 1 g flight envelope of the F-15. No stalls occurred, and no more than two PLA recycles were required. Factors contributing to the large improvement in success, compared to previous phases, included the LOD, the segment 1 hold logic, and the revised augmentor permission logic, as will be shown later.

NASA  
DFRF83-053

## DEEC PHASE 4 IDLE TO MAXIMUM TRANSIENTS

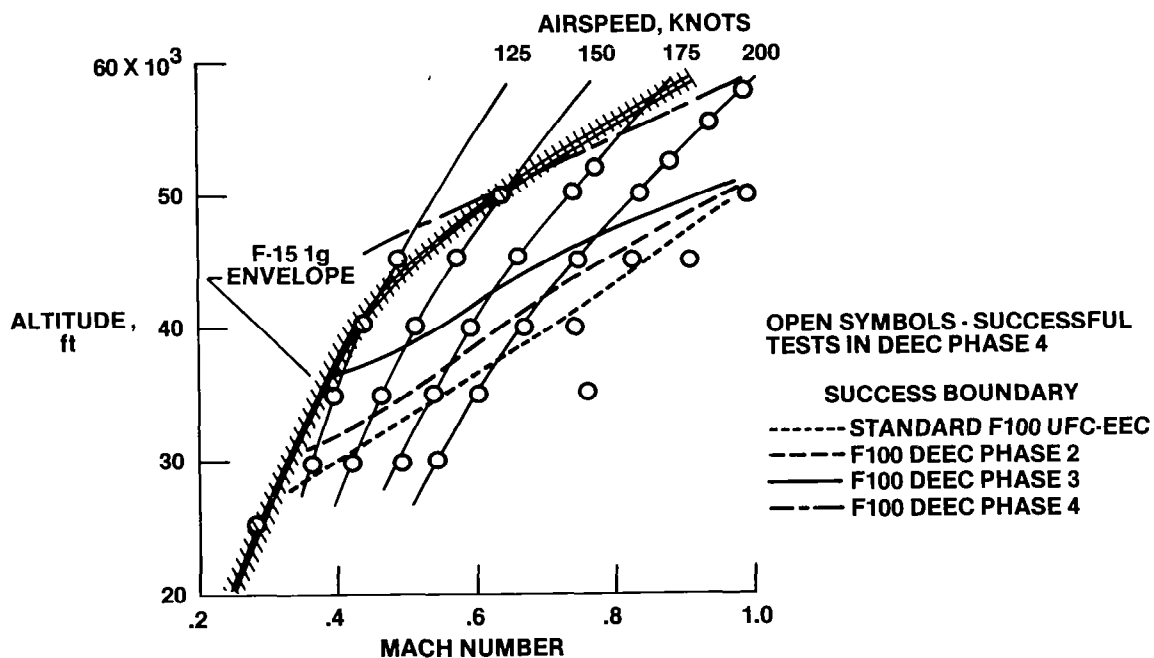

## FAST ACCELERATION

The phase 4 DEEC logic had the capability to allow the augmentor sequencing to begin immediately on idle-to-maximum snaps at low altitude-high airspeed conditions. An example is shown below, at 21,000 ft and 400 knots. Following the snap from idle-to-maximum at  $t = 0$  sec, the gas generator spoolup and augmentor sequencing began. Segment 1 quickfill began at  $t = 0.2$  sec. The light occurred at  $t = 1$  sec. The logic held the sequence valve in segment 1 until 80 percent of the requested fan speed was achieved and then allowed the remaining segments to sequence normally. The entire transient was completed within 4.5 sec. Without the fast acceleration logic, this transient would have taken almost 7 seconds. The fast acceleration logic is inhibited following a bodie and is gradually washed out in the region above the line shown in the phase 4 augmentor configuration chart.

### DEEC Phase 4 "Fast Accel" Idle-To-Max Snap 21,000 Ft, 400 Knots

NASA  
DFRF83-482

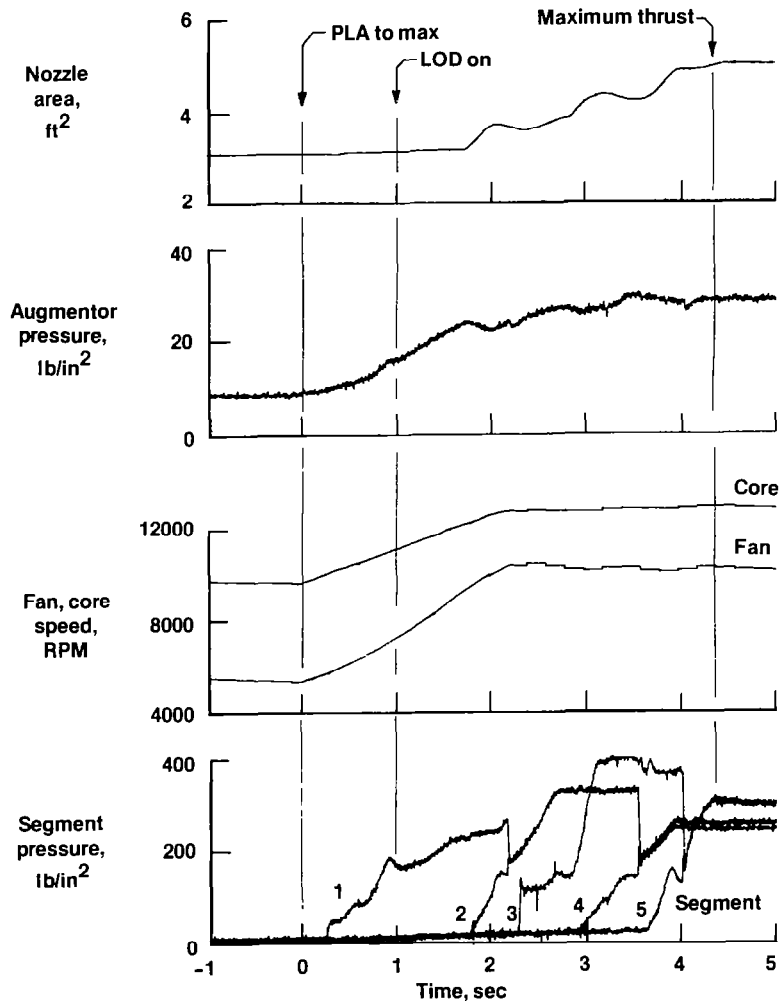

## SUMMARY OF AUGMENTOR IMPROVEMENTS

The chart below summarizes the improvement in augmentor performance between the standard F100 engine and the DEEC phase 4 results. With the addition of the DEEC logic, LOD, damped quickfill sensor, automatic PLA recycle, and tailored spray rings, all idle-to-maximum transients were successful, even with the segment 1 limiting override on. This increase in altitude capability was as much as 15,000 ft. Additional tests will be required to verify that this improvement will be realized on all DEEC-equipped engines over a range of test altitudes, airspeeds, and temperatures.

NASA  
DFRF83-053a

### F-15/DEEC IDLE TO MAXIMUM TRANSIENTS

