

CONTROL TECHNOLOGY FOR FUTURE AIRCRAFT PROPULSION SYSTEMS

John R. Zeller, John R. Szuch,
Walter C. Merrill, Bruce Lehtinen, and James F. Soeder
NASA Lewis Research Center
Cleveland, Ohio

SUMMARY

The thrust toward improved aircraft powerplants for both military and civilian applications has created a need for significantly more sophisticated engine control systems. The improvements in better thrust-to-weight ratios have usually demanded the manipulation of more control inputs. The computational and scheduler needs associated with these additional tasks severely tax the capabilities of the well-proven analog hydromechanical fuel controllers. As a result, new technological solutions to the engine control problem are being put into practice. Electronic controllers, especially digital computer-based, are being applied to the need. The digital electronic engine control (DEEC) system is one very sophisticated step in the evolution to digital electronic engine control.

This paper is intended to:

- (1) enumerate the technology issues being addressed to ensure a growth in confidence in sophisticated electronic controls for aircraft turbine engines; and
- (2) establish the needs of a control system architecture which will permit propulsion controls to be functionally integrated with other aircraft systems, such as flight controls.

This paper will include areas of technology being studied by the NASA Lewis Research Center (LeRC), either alone or in conjunction with the Air Force Aeropropulsion Laboratory. The work encompasses the areas of: (1) control design methodology; (2) improved modeling and simulation methods; and (3) implementation technologies. Objectives, results and future thrusts will be summarized.

The emerging new technologies of electronic hardware and software being planned for future engine controls raise some new issues. One is the prediction of the reliability and integrity of these technologies as they take on the new task of aircraft turbine engine control. Another is the validation of these systems which are based on software as well as hardware, and incorporation of computational innovations for which the industry has little operational experience. An example of the second item is the desire to accommodate faults by diagnosing them and reconfiguring the control on-line. Validation methods for fault-tolerant hardware/software systems require new and innovative approaches to address these issues.

Coupled with improved propulsion system performance is the evolution in the military aircraft arena toward highly maneuverable weapons systems, featuring such items as relaxed stability, forward swept wing technology, vectored nozzles, and more. For total system performance goals to be achieved, there will need to be a certain amount of dynamic coupling of the aircraft's powerplant with the flight control. This will lead to functional integration of various aircraft control subsystems, including engine and inlet control subsystems. The technology needed to design, implement and validate such an integrated system is being pursued but much remains to be done. The major issues concerning integrated control, and some recommendations based on the results of some recent Langley Research Center (LaRC)/LeRC contracted studies, will conclude this paper.

ENGINE CONTROLS EVOLUTION

Over the years the control complexity of aircraft turbine engines has increased significantly. This complexity is required to extract more thrust for less weight from the turbomachinery. The figure below shows this increased complexity in terms of the number of controlled variables. Initially the system only had to control a single variable-engine fuel flow. Today an engine such as the joint technology demonstrator engine (JTDE) can have as many as 9 to 10 controlled variables. To accommodate this increased complexity, the proven hydromechanical control, which has been the implementation device for many years, is giving way to electronic controls and, in most cases, digital electronic controls. The electronic approach offers a great deal more computational capability than is possible with a hydromechanical computing device.

National Aeronautics and
Space Administration
Lewis Research Center

AERODYNAMICS AND ENGINE SYSTEMS DIVISION

ENGINE CONTROLS EVOLUTION

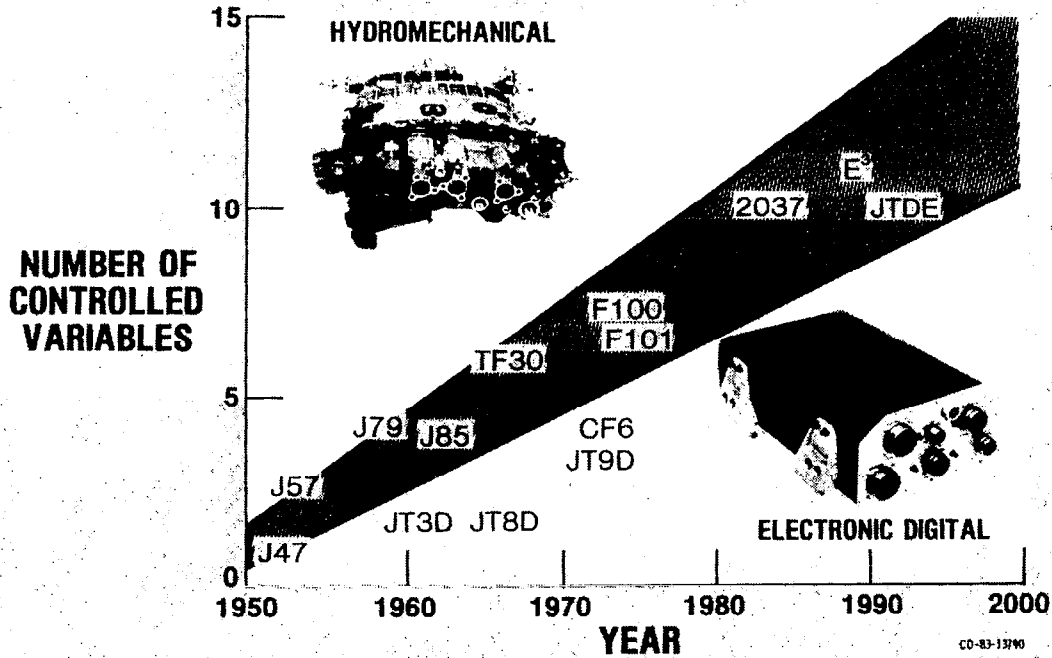

PROPULSION CONTROL HARDWARE

This figure shows the many different components that make up an electronic propulsion control system. Since we are entering a new application environment, these components (sensors, actuators, computers, and others) will not have the maturity that exists with elements of hydromechanical control. Thus LeRC is working on technology which will provide components that stress simplicity, reliability, and low cost for the future electronic propulsion controllers. The areas most actively being pursued are the sensors and actuators. To minimize problems of signal transmission, optical sensing devices are being developed. The next figure will summarize the important LeRC thrusts in these areas.

Lewis Research Center

NASA
National Aeronautics and
Space Administration

PROPULSION CONTROL HARDWARE

RESEARCH OBJECTIVES:

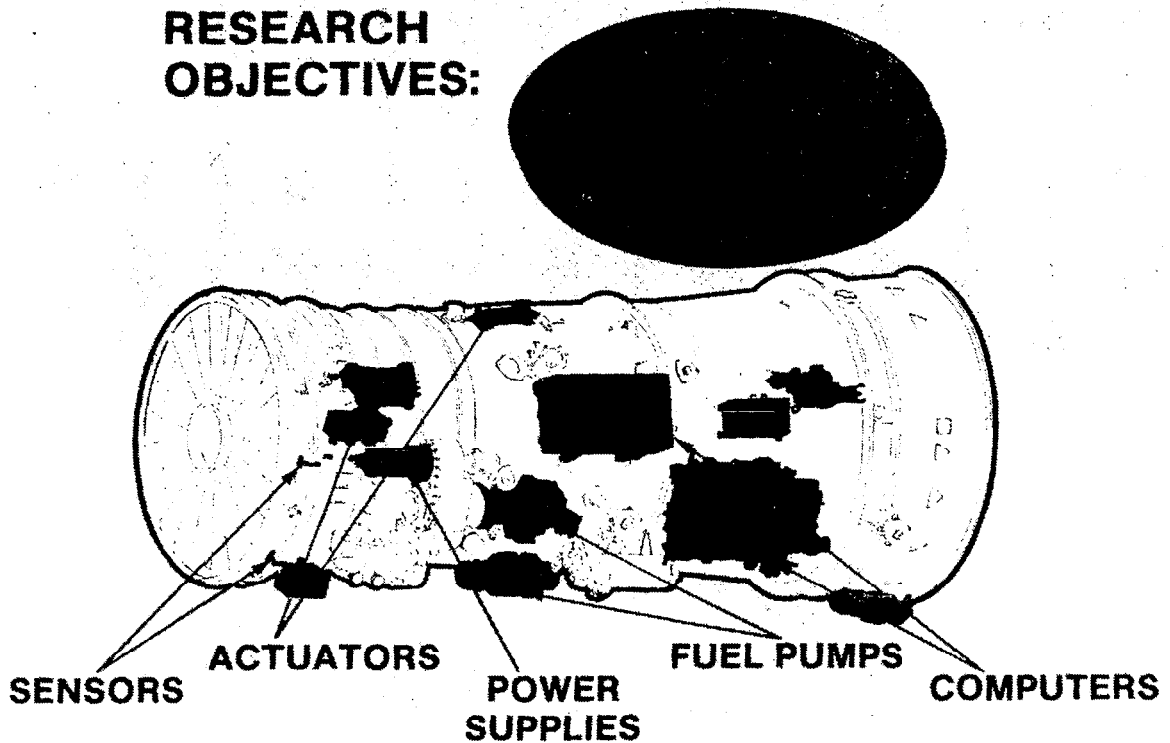

C-80 200
5000 8 80

OPTICAL SENSOR/ACTUATOR ACTIVITY

The optical tachometer and position encoders were the first remote sensors developed for aircraft systems. Remote sensing is when no electrical energy is directed to the sensor. A fiberoptic wave guide connected the sensors with the source and detector. The rotary encoder is a nine-bit 360° encoder and the tachometer is a nine-pulse/revolution encoder. The sensors were installed on an F100 engine tested in an altitude chamber. These sensors worked during more than 100 hours of engine testing. The sensors were built under contract, by Spectronics, a division of Honeywell.

The optical gas temperature sensor was developed under contract by United Technologies Research Center (UTRC). Operation of this sensor is based on the temperature-dependent absorptive characteristics of a rare-earth- (europium-) doped optical fiber. Rare-earth materials like europium have energy states close to the ground state. These states are optically connected to higher excited states with energy differences that correspond to wavelengths in the visible region. The strength of absorption is a function of the number of electrons in the state from which the transition originates. The number of electrons in each state is a unique function of temperature. Optical energy directed through the rare-earth is absorbed. The strength of the absorption is dependent on temperature of the rare-earth material. A rare-earth sensor was delivered to LeRC and will be installed in the inter-turbine region of a turboshaft engine. Temperatures in this region are expected to approach 840° C. The sensor tests on the engine will occur in the near future.

Actuators that are powered or controlled by light may be part of future aircraft systems. In these schemes the actuator is driven by an electrohydraulic servovalve. Hydraulic power is supplied to the servovalve. In one scheme optical energy is converted to electrical energy (solar cell). This electrical energy is used to drive the torque motor directly. In another scheme optical power is used to control the flow of electrical energy to the torque motor. In the second configuration, electrical energy is generated at the point of use. Optical control signals generated at the control computer are sent to a phototransistor. The phototransistor drives a power transistor that controls power to the actuator. UTRC, under contract to LeRC, is developing high-temperature components for this type of application. These devices must operate at temperatures to 260° C. Gallium arsenide is being used for devices because of the high temperatures. The validity of design has been verified by operating a gallium arsenide - a junction field effect transistor switch - with a gallium arsenide phototransistor at 260° C. A current of 50 mA was switched into a resistive load with 235 μW of optical power incident on the phototransistor. A follow-on program with Pratt and Whitney Aircraft and UTRC to design and build a high temperature photoswitch that will control power to a direct drive servovalve is planned. This servovalve will drive a two-dimensional exhaust nozzle actuator on a JTDE engine in the 1986 to 1987 time frame.

LeRC OPTICAL SENSOR/ACTUATOR ACTIVITY

- OPTICAL TACHOMETER & POSITION ENCODER
TESTED ON F 100 ENGINE (ALTITUDE CHAMBER)**
- OPTICAL GAS TEMPERATURE SENSOR
FOR TURBINE REGION (T 700 ENGINE)**
- OPTICAL CONTROL OF DIRECT DRIVE
ACTUATOR (P&W JTDE ENGINE)**

F100 CONTROL INPUTS

The figure below shows the complexity of a modern aircraft turbine engine in terms of its controlled variables. This Pratt and Whitney F100 engine shows six manipulable input variables. This number of inputs, many of which will effect a number of engine parameters, can benefit from some organized method for designing the control law. Modern multivariable design techniques such as linear quadratic regulator (LQR) and the frequency domain approach of the multivariable Nyquist array (MNA) offer potential methods for organized design. LeRC and industry have evaluated this technology for the turbine engine control problem.

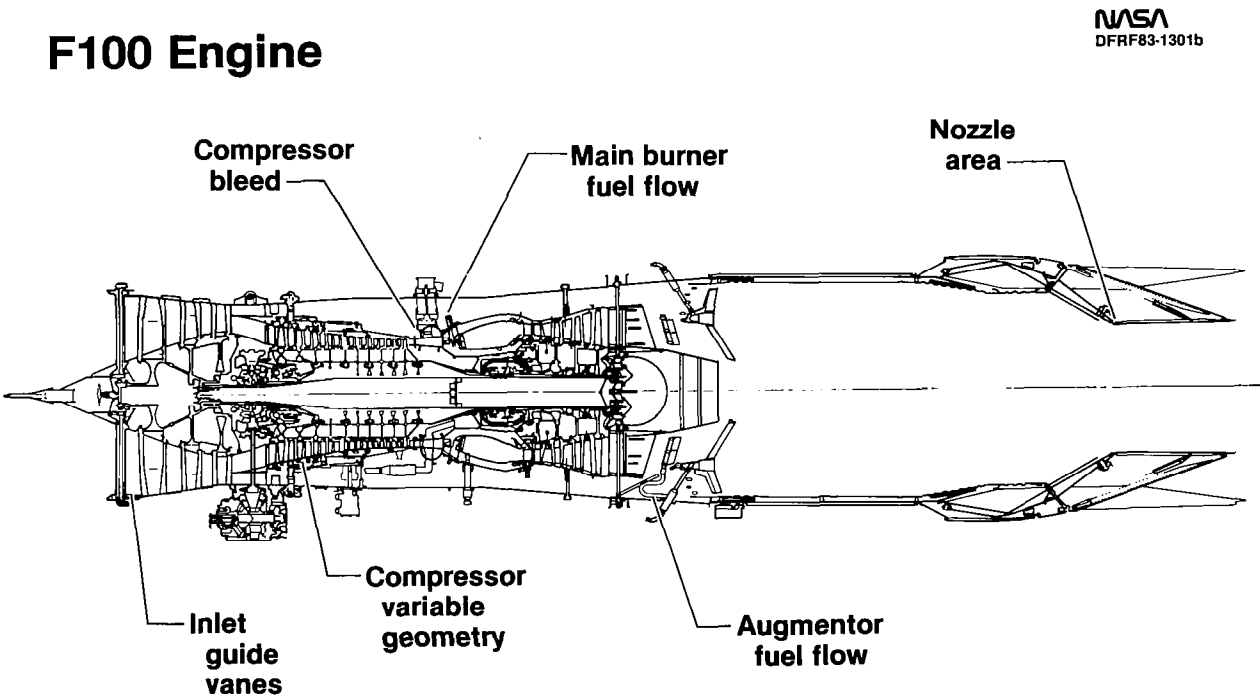

F100 MULTIVARIABLE CONTROL SYNTHESIS

The figure below shows the interrelationships of the participants in a government-sponsored program to evaluate control design methodology. The multivariable control synthesis (MVCS) program was jointly sponsored by the Air Force Aeropropulsion Laboratory (AFAPL) and the LeRC. Pratt and Whitney, Government Products Division, was contracted to provide engine models and control design criteria for the F100 engine. Systems Control Technology (SCT), formerly Systems Control Incorporated, designed a multivariable control based upon LQR. The control algorithm was put into software by LeRC personnel. It was evaluated and debugged using a real-time engine simulation and then evaluated in a real engine in a LeRC altitude facility. The program was quite successful and demonstrated that the design methodology, although restricted to linear systems, could be extended to a highly nonlinear process, such as turbine engine control, by creative engineering judgment.

NASA
CS-79-2747

F100 MVCS PROGRAM PARTICIPANTS

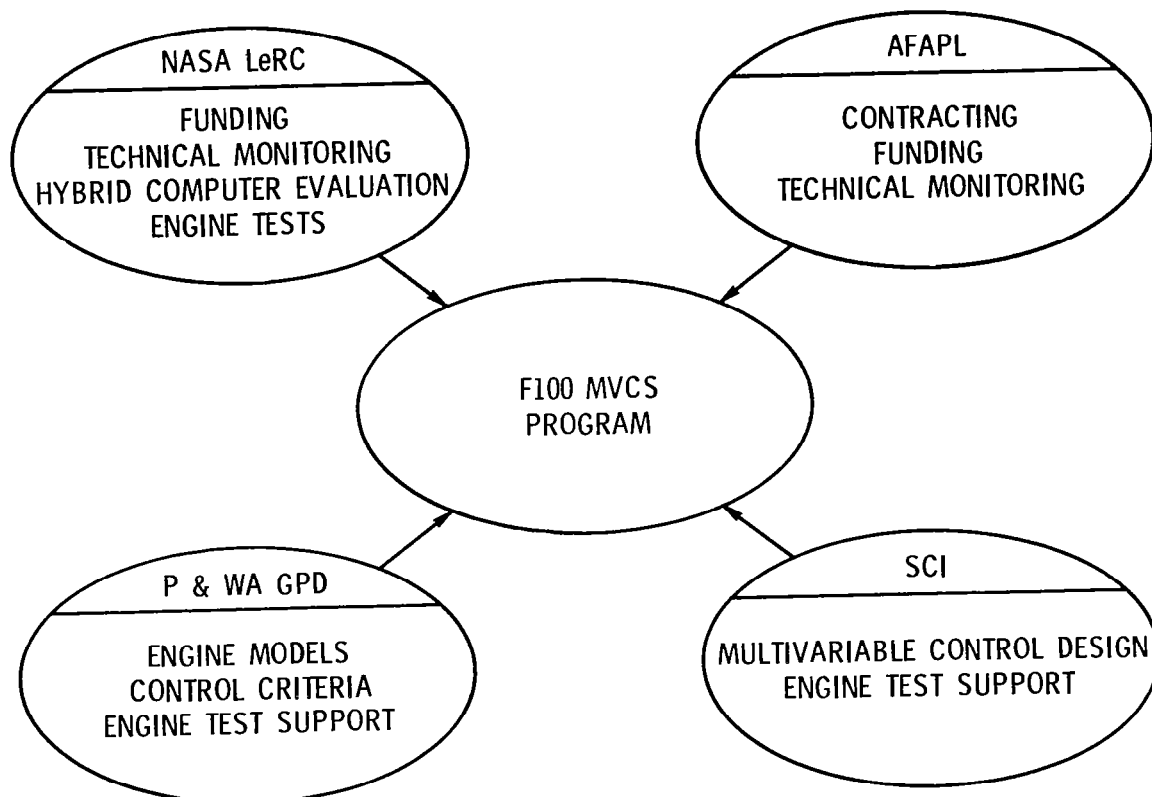

F100 MULTIVARIABLE CONTROL STRUCTURE

A simplified block diagram of the resultant multivariable control (MVC) is shown below. The main elements are a simplified dynamic engine model and a proportional-plus-integral (PI) controller. The engine model, contained in software within the digital electronic computer control, is the mechanism by which a family of linear operating-point PI controllers can be tied together to provide a control which works smoothly over the entire operating envelope. The model accepts the pilot input as well as measurements of the environmental conditions, and provides nominal values of the control inputs. It also provides the engine conditions (pressure, temperatures, and speeds) which are desired for those input conditions. The multivariable PI control block then compares the actual engine conditions against those desired and trims out the errors by modifying the control inputs. The gains of the PI control are functions of the operating conditions since they have been selected by linear design methods. Providing the functional relationships is a task readily accomplished by a digital computer.

F-100 MVC STRUCTURE

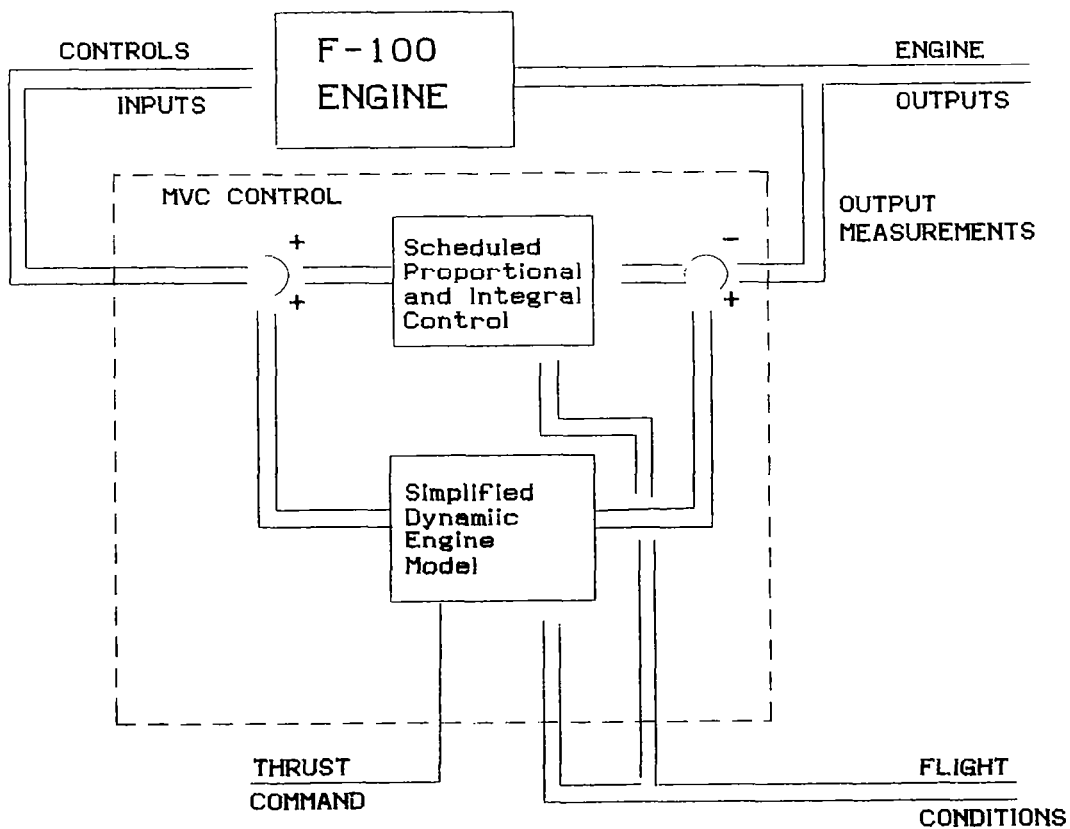

SENSOR FAILURE DETECTION AND ACCOMMODATION

As mentioned earlier, reliability of the components making up an electronic engine control is a real concern. The sensors used will be ones which produce an output compatible with an electronic device. For many of these sensors the engine control application will be new. Hardware redundancy will help overcome the reliability deficiencies; however, this is a costly solution.

Fortunately, the theory of multivariable systems provides some valuable methods for implementing techniques called analytical redundancy. This figure shows how analytical redundancy can detect, isolate, and accommodate sensor failures. The principle behind advanced sensor failure detection/isolation/accommodation (DIA) is the replacement of hardware redundancy with analytical redundancy. In the hardware redundant case multiple, similar sensors (for example, three T4 sensors) could be used to detect failures in a single sensor through a fairly straightforward majority voting procedure. Once a failure is detected, the faulty sensor information is excluded from use in the control system. Multiple sensors would also be required for other measured engine variables (for example, P4 and N). The advantage of this approach is the conceptual simplicity of the decision process. The disadvantages are the cost and weight of the additional sensors.

In an analytically redundant case a single sensor would be used for each measured engine variable. Sensor failures would be detected by comparing the measurement (here T4) with the estimate (EST) of T4. The analytically redundant information in dissimilar sensors such as P4 and N, and a reference model of the engine, are used to generate T4, EST. A fault is detected when a large error between measurement and estimate exists. Once a failure is detected, T4, EST is substituted for the faulty measurement in the control system.

SENSOR FAILURE DETECTION & ACCOMMODATION

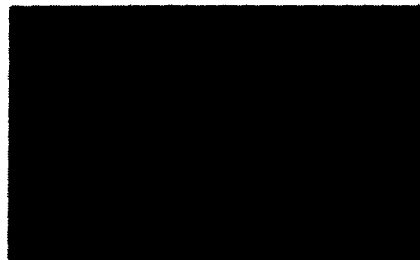
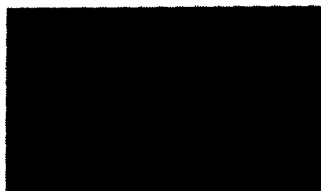
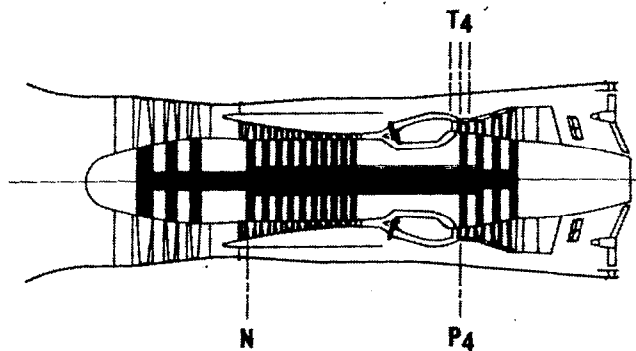

CO-82 134W

COMPUTATIONAL FLOW OF AUGMENTED TURBOFAN ENGINE SIMULATION

The electronic control technology work done thus far has benefited significantly from the use of accurate engine simulations. Real-time simulations have been invaluable in checking digital control software. Accomplishing a real-time simulation of a complete aircraft turbine engine is not always easily done. The figure below is an example that shows the complexity involved in the modeling of an engine. Compressor and turbine maps, mixing volumes, rotor inertias and other engine characteristics create computational nightmares. Not only are the model's steady-state relationships difficult to compute, but the numerous differential equation terms further complicate the real-time computation objective.

COMPUTATIONAL FLOW DIAGRAM OF AUGMENTED TURBOFAN ENGINE SIMULATION

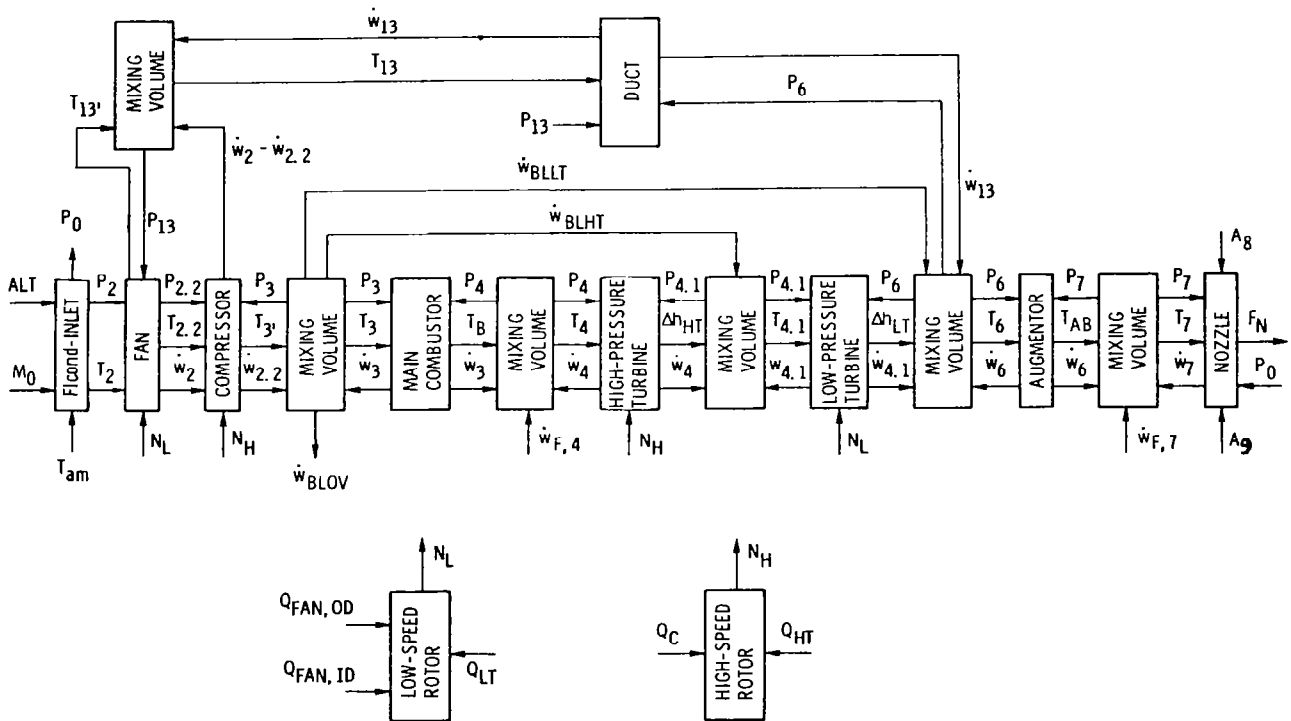

REAL-TIME ENGINE SIMULATION USING A HYBRID COMPUTER

LeRC has used a hybrid computer facility to provide a real-time high fidelity model for engines such as the F100. This diagram shows how the real-time capability is achieved. The digital portion of the hybrid is used to provide function generation for the compressor, combustor, and turbine maps. The dynamic terms are integrated, using the hybrid's analog components. A digital controller can then exercise the real-time engine through analog inputs and outputs.

NASA
CS-74623

REAL-TIME ENGINE SIMULATION USING A HYBRID COMPUTER

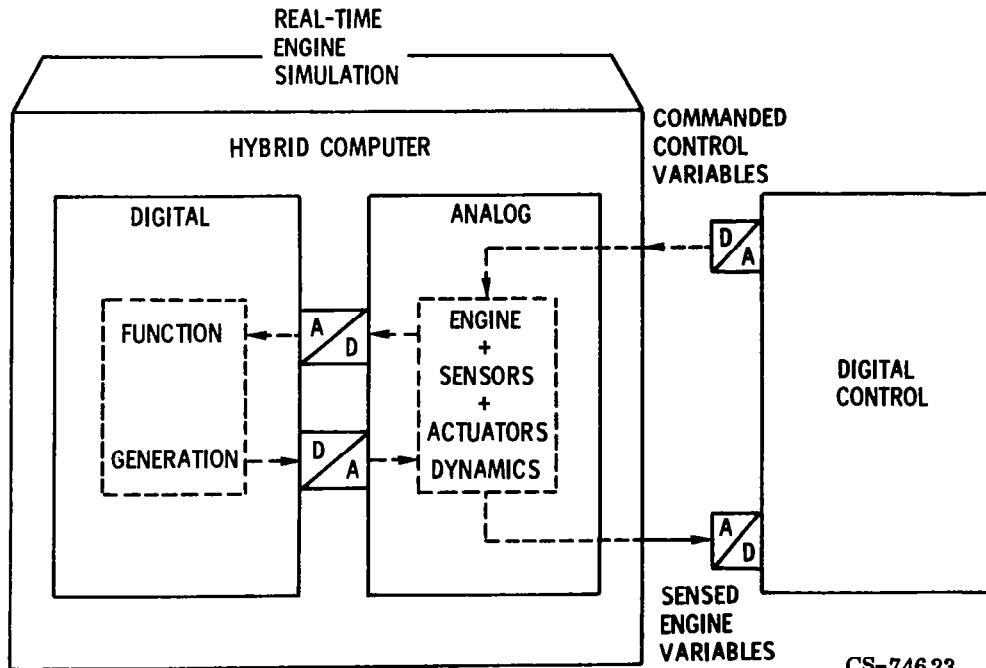

USING MICROPROCESSORS FOR REAL-TIME SIMULATION

The use of real-time engine simulations is not limited to control law validations. They are also needed in piloted simulators to provide realistic engine models for total vehicle evaluation. To make real-time simulators more readily available at a lower cost and in a compact form, there is an LeRC program to use parallel microprocessors to accomplish real-time engine simulation. Below is a photograph of a forerunner to the parallel processor real-time engine simulator (RTES). The particular unit shown is a single microprocessor simulator of a rather simple helicopter engine. This unit will serve as a RTES in a vertical motion simulator at the Ames Research Center (ARC) during helicopter control studies.

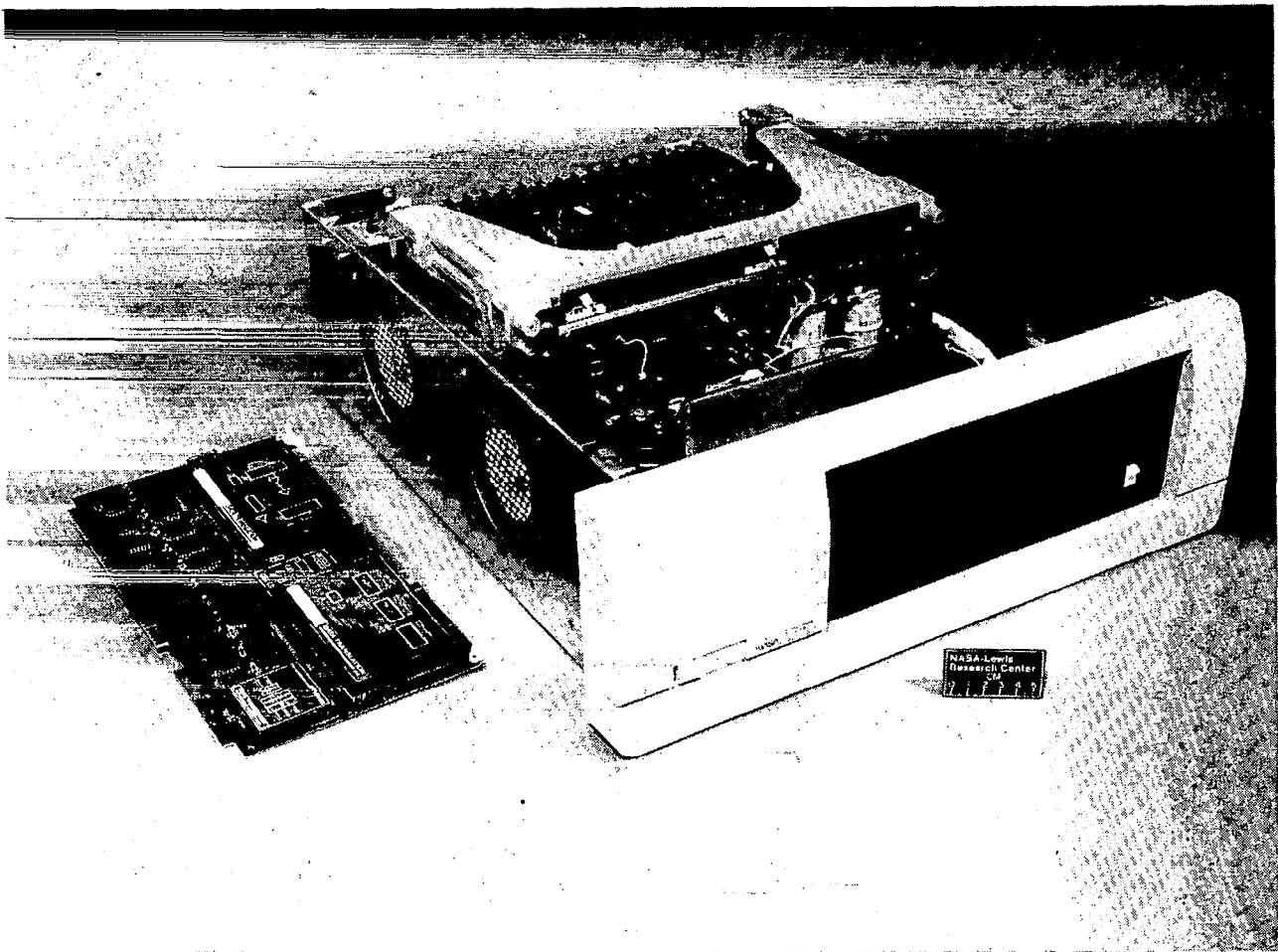

PROGRESS TOWARD INTEGRATED CONTROL

Many programs have been accomplished to provide the technology needed for electronic propulsion controllers. The bubble on the top left of the next figure contains the acronyms for some of these programs. The aircraft is also evolving to electronic control systems for fire control, flight control and other functions. Programs have been undertaken to integrate portions of the aircraft controls. A small sampling is indicated in the bubble on the lower left. However, studies have shown that more maneuverability and other performance improvements can be accomplished by integrating the propulsion system with the other aircraft control systems. The benefits of integrating the supersonic inlet and engine, for example, was demonstrated in the integrated propulsion control system (IPCS) program. The design methods for integrated control systems (DMICS) program is looking at the design tools needed to come up with an integrated aircraft/propulsion control law. The IAPSA program is evaluating the architecture needed to support a control law for a vehicle with strong propulsion/aircraft coupling. These programs are only the beginning. Many issues are yet to be resolved before an aircraft with a highly integrated (propulsion/aircraft) control system will become an operational entity.

PROGRESS TOWARD INTEGRATED CONTROL

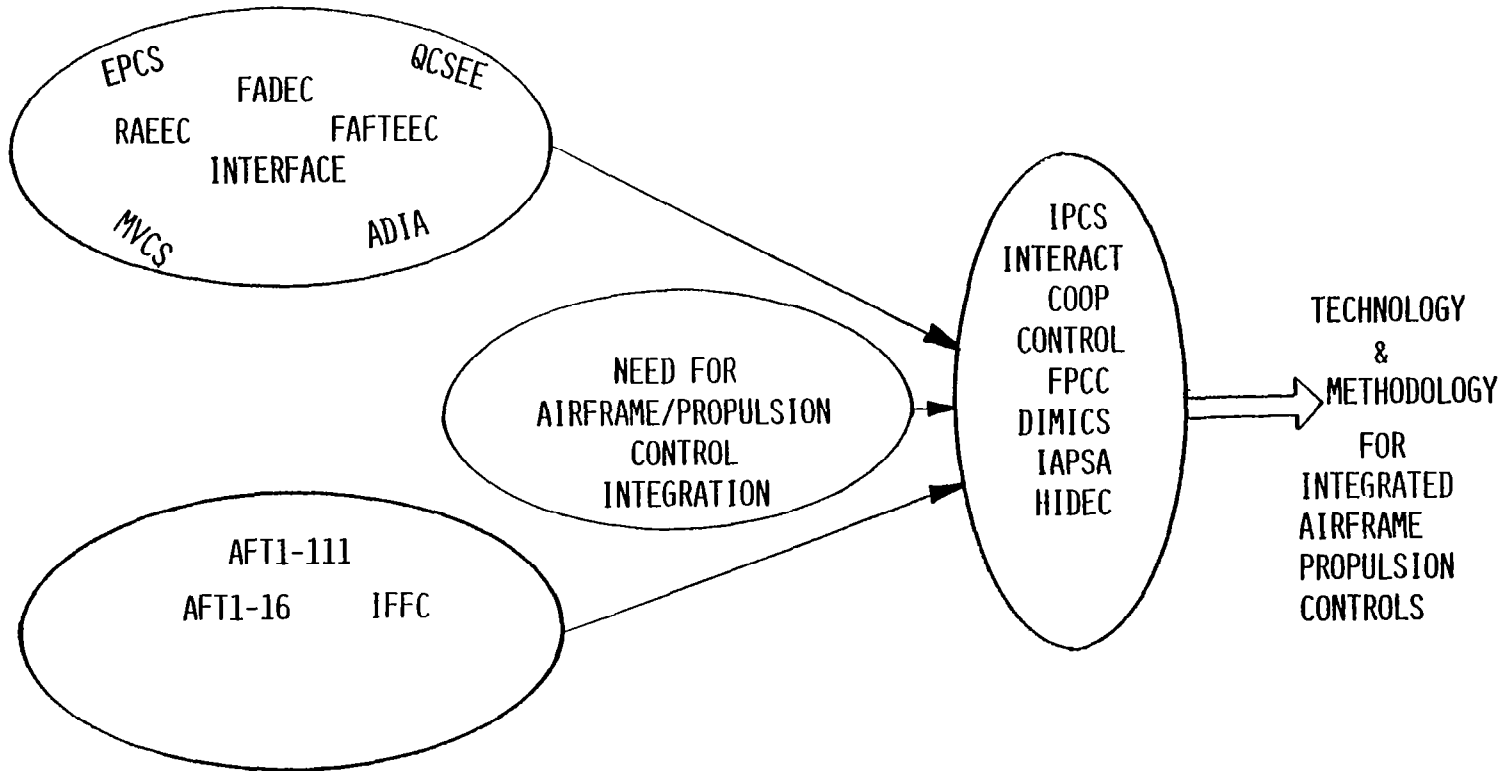

UNRESOLVED ISSUES

This last figure illustrates some of the unresolved issues pertaining to electronic controls for aircraft propulsion systems and control systems which integrate aircraft and propulsion functions.

With regard to digital electronic propulsion controls, reliability is an area requiring a large portion of the design effort. The severe environment of engine-mounted computers, sensors, and actuators results in designs using redundancy for fault-tolerance. How best to achieve high reliability through a combination of hardware and software and how to manage redundancy are issues still being resolved. Also, once a design is complete, methods for validating the final design under all conditions and possible failure modes are still evolving. Both the redundancy and the complexity of the control algorithm itself make validation difficult.

Functionally integrating the aircraft and propulsion system requires the development and maturing of some new technology. Design tools are needed for handling control design of an integrated system where hierarchical considerations may be important. Present multivariable design methods may or may not be adequate. Also, the architecture of the resultant control may require extensive cross communication between distributed elements. In addition to the new technology, there needs to be improved reliability analysis tools and better methods for performance validation. Since an integrated control crosses boundaries of responsibility, some method of bridging the potential gap must be agreed upon. The issue of standard languages, processor and data bus become involved in this resolution. At the present time there seems to be a lack of agreement on the adequacy of the present military standards being mandated. These issues must be resolved.

UNRESOLVED ISSUES

ELECTRONIC PROPULSION CONTROL

- RELIABILITY OF HARDWARE/SOFTWARE**
- VALIDATION PROCEDURES**

**ADVANCED CONTROL ALGORITHMS
REDUNDANCY MANAGEMENT CONCEPTS**

INTEGRATED AIRFRAME/PROPULSION CONTROL

- TECHNOLOGY NEEDS
DESIGN TOOLS
ARCHITECTURAL CONSIDERATIONS**
- RELIABILITY ANALYSIS TOOLS**
- VALIDATION METHODS**
- ISSUE OF STANDARDS
DATA BUS LANGUAGE PROCESSOR**